

Electric Cooker Models
17EC, 17ECS, ESW and EWBS
Installation, Operation, Service & Parts Manual

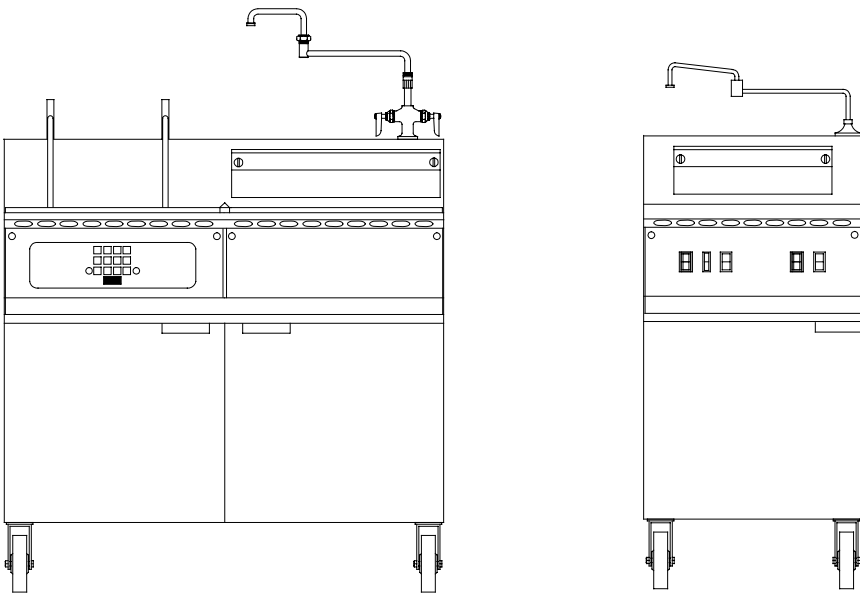

Frymaster, a member of the Commercial Food Equipment Service Association, recommends using CFESA Certified Technicians.

24-Hour Service Hotline 1-800-551-8633

Online manual updated
06/07/04

*** 8195680 *** MAY 2003

NOTICE

IF, DURING THE WARRANTY PERIOD, THE CUSTOMER USES A PART FOR THIS ENODIS EQUIPMENT OTHER THAN AN UNMODIFIED NEW OR RECYCLED PART PURCHASED DIRECTLY FROM FRYMASTER/DEAN, OR ANY OF ITS AUTHORIZED SERVICE CENTERS, AND/OR THE PART BEING USED IS MODIFIED FROM ITS ORIGINAL CONFIGURATION, THIS WARRANTY WILL BE VOID. FURTHER, FRYMASTER/DEAN AND ITS AFFILIATES WILL NOT BE LIABLE FOR ANY CLAIMS, DAMAGES OR EXPENSES INCURRED BY THE CUSTOMER WHICH ARISE DIRECTLY OR INDIRECTLY, IN WHOLE OR IN PART, DUE TO THE INSTALLATION OF ANY MODIFIED PART AND/OR PART RECEIVED FROM AN UNAUTHORIZED SERVICE CENTER.

 DANGER

Improper installation, adjustment, alteration, service, or maintenance can cause property damage, injury, or death. Read the installation, operating, and service instructions thoroughly before installing or servicing this equipment.

 DANGER

For your safety, do not store or use gasoline or other flammable liquids or vapors in the vicinity of this or any other appliance.

 DANGER

This equipment is intended for indoor use only. Do not install or operate this equipment in outdoor areas.

 DANGER

Do not operate this equipment unless it has been properly installed and checked by qualified personnel.

 DANGER

Do not operate this equipment unless all covers and access panels are in place and properly secured.

 DANGER

Do not attempt to repair or replace any component of this equipment unless power to the unit has been disconnected.

 DANGER

If the power supply cord is damaged, it must be replaced by the manufacturer or its service agent or similarly qualified persons in order to avoid a hazard.

 DANGER

Use caution when setting up, operating, or cleaning this equipment to avoid contact with heated surfaces.

 DANGER

Do not use water jets to clean this equipment.

ELECTRIC COOKER MODELS 17EC, 17ECS, ESW AND EWBS

TABLE OF CONTENTS

CHAPTER 1: General Information

1.1	Parts Ordering and Service Information.....	1-1
1.2	Safety Information.....	1-1
1.3	Equipment Description.....	1-2
1.4	Installation, Operating, and Service Personnel.....	1-3
1.5	Definitions.....	1-3
1.6	Shipping Damage Claim Procedure.....	1-4

CHAPTER 2: Installation Instructions

2.1	General Installation Requirements.....	2-1
2.2	Caster/Leg Installation.....	2-2
2.3	Pre-Connection Preparations.....	2-2
2.4	Connection to the Electrical Power Supply.....	2-3

CHAPTER 3: Operating Instructions

3.1	Spaghetti Magic II Controller (As Used on 17EC and 17ECS Units).....	3-1
3.2	Computer Magic III Controller (As Used on EWBS Units).....	3-3
3.3	Thermostat Control and Switch Panel (As Used on ESW and EWBS Units).....	3-8
3.4	Boiling Out the Cookpot.....	3-9

CHAPTER 4: Preventive Maintenance

	Daily Preventive Maintenance.....	4-1
--	-----------------------------------	-----

CHAPTER 5: Operator Troubleshooting

5.1	Introduction.....	5-1
5.2	Operator Troubleshooting Guide.....	5-2
5.3	Replacing the Controller (17EC/17ECS and EWBS with CM III Computer).....	5-3
5.4	Replacing Fuses in 17EC and 17ECS Models.....	5-4

CHAPTER 6: 17EC/17ECS Service Procedures & Parts

6.1	Functional Description.....	6-1
6.2	Accessing Equipment for Servicing.....	6-2
6.3	Replacing Equipment Components.....	6-2
6.3.1	Replacing the Computer.....	6-2
6.3.2	Replacing Electronic Components Other than the Computer.....	6-2
6.3.3	Replacing a Heating Element.....	6-3
6.3.4	Replacing the High-Limit Thermostat.....	6-5
6.3.5	Replacing a Water-Level Sensor.....	6-6
6.3.6	Replacing the Temperature Probe.....	6-6
6.3.7	Replacing the Pressure Regulator or Solenoid Valve.....	6-7
6.3.8	Replacing the Water Faucet.....	6-7
6.3.9	Replacing a Basket Lift Motor or Microswitch.....	6-8
6.3.10	Replacing the Cookpot or Rinse Tank.....	6-9
6.4	Technician Troubleshooting.....	6-11

6.4.1	How the Power Supply System Works	6-11
6.4.2	How the Computer Works.....	6-11
6.4.3	How the Autofill/Autoskim System Works	6-12
6.4.4	How the Water Heating System Works	6-12
6.4.5	How the Basket Lift System Works	6-13
6.4.6	Technician Troubleshooting Guides	6-14
	Troubleshooting the 24VAC Power Supply System.....	6-14
	Troubleshooting the 24VAC Power to Computer.....	6-15
	Troubleshooting the Autofill System	6-16
	Troubleshooting the Water Heating System	6-17
	Troubleshooting the Basket Lift System.....	6-18
6.5	Parts List.....	6-19
	Accessories.....	6-19
	Basket Lift Components.....	6-20
	Cabinetry	6-22
	Cookpot, Rinse Tank, and Drain Components.....	6-24
	Electronics.....	6-26
	Water Supply System Components.....	6-28
6.6	Wiring Diagram.....	6-29

CHAPTER 7: ESW/EWBS Service Procedures & Parts

7.1	Functional Description	7-1
7.2	Accessing Equipment for Servicing.....	7-3
7.3	Replacing Equipment Components.....	7-3
7.3.1	Replacing the Computer.....	7-3
7.3.2	Replacing Electronic Components Other than the Computer	7-3
7.3.3	Replacing a Heating Element.....	7-4
7.3.4	Replacing the High-Limit Thermostat	7-5
7.3.5	Replacing a Water-Level Sensor.....	7-6
7.3.6	Replacing the Temperature Probe.....	7-6
7.3.7	Replacing the Pressure Regulator or Solenoid Valve	7-8
7.3.8	Replacing the Water Faucet	7-8
7.3.9	Replacing a Basket Lift Motor or Microswitch.....	7-9
7.3.10	Replacing the Cookpot.....	7-10
7.4	Technician Troubleshooting.....	7-12
7.4.1	How the Power Supply System Works	7-12
7.4.2	How the Computer Works.....	7-12
7.4.3	How the Autofill and Skim Systems Work.....	7-13
7.4.4	How the Water Heating System Works	7-13
7.4.5	How the Basket Lift System Works.....	7-14
7.4.6	Technician Troubleshooting Guides	7-15
	Troubleshooting the 24VAC Power Supply System.....	7-15
	Troubleshooting the Autofill System	7-16
	Troubleshooting the Water Heating System	7-17
	Troubleshooting the Basket Lift System.....	7-18
7.5	Parts List.....	7-19
	Accessories.....	7-19
	Basket Lift Components.....	7-20
	Cabinetry	7-22

	Control Components.....	7-24
	Cookpot and Drain Components	7-25
	Electronics	7-26
	Water Supply System Components.....	7-28
7.6	Wiring Diagrams	7-30

THIS PAGE INTENTIONALLY LEFT BLANK.

ELECTRIC COOKER MODELS 17EC, 17ECS, ESW AND EWBS

CHAPTER 1: GENERAL INFORMATION

1.1 Parts Ordering and Service Information

In order to assist you as quickly as possible, the Frymaster Factory Authorized Service Center (FASC) or Service Department representative requires certain information about your equipment. Most of this information is printed on a data plate affixed to the inside of the door.

Parts orders may be placed directly with your local FASC or distributor. Included with cookers when shipped from the factory is a list of FASCs. If you do not have access to this list, contact the Frymaster Technical Service Department at 1-800-551-8633 or 1-318-865-1711.

When ordering parts, the following information is required:

Model Number: _____
Serial Number: _____
Voltage: _____
Item Part Number: _____
Quantity Needed: _____

Service information may be obtained by contacting your local FASC/Distributor. Information may also be obtained by calling the Frymaster Technical Service Department at 1-800-551-8633 or 1-318-865-1711. When requesting service, please have the following information ready:

Model Number: _____
Serial Number: _____
Voltage: _____

In addition to the model number, serial number, and voltage, please be prepared to describe the nature of the problem and have ready any other information that you think may be helpful in solving your problem.

RETAIN AND STORE THIS MANUAL IN A SAFE PLACE FOR FUTURE USE.

1.2 Safety Information

Before attempting to operate your unit, read the instructions in this manual thoroughly.

Throughout this manual, you will find safety notations enclosed in boxes similar to the ones illustrated below and on the following page.

 **CAUTION**

CAUTION boxes contain information about actions or conditions that *may cause or result in malfunction of your equipment.*

 **WARNING**

WARNING boxes contain information about actions or conditions that *may cause or result in damage to your equipment*, and which may cause your equipment to malfunction.



DANGER

DANGER boxes contain information about actions or conditions that *may cause or result in injury to personnel*, and which may cause damage or malfunctioning of your equipment

1.3 Equipment Description

The automatic, high-volume Electric Cooker models ESW and EWBS are specifically designed for rethermalizing pre-cooked packaged foods, boiling seafood, or cooking fresh foods and pasta. All models are capable of delivering up to 50 pounds (26 kg) of product per hour.

Model Comparison:

17EC/17ECS: The 17EC and 17ECS series feature two 8.5-kilowatt heating elements in a 16.5 gallon (62.5 liter) stainless steel cookpot. A specially modified SMS II computer controls the cooking process and the automatic filling (Autofill) and automatic skimming (Autoskim) features. The Autoskim feature sprays water onto the surface of the water, forcing starch across to the overflow drain. This eliminates loss of cooking time associated with removing excess starch buildup. It also keeps the cooking water at the optimum level by replacing water evaporated during the cooking process. These models are also equipped with automatic basket lifts. The cookpot is safeguarded against over filling and boilover by a large overflow drain and a starch diverter. “SD” following the model designation indicates a stainless steel cookpot and door, and an enameled cabinet. “SC” following the model designation indicates all stainless steel components. The 17ECS model consists of a cooker and rinse tank combined in a single cabinet. The 17EC model has no rinse tank. Both models have a manually operated faucet equipped with a flexible hose.

ESW: The ESW series features a 13-kilowatt cookpot holding 16.5 gallons (62.5 liters) of water. A rocker-type ON/OFF switch controls electrical power to the unit. A manually adjusted thermostat regulates water temperature, and a 3-position rocker switch (BOIL-IDLE-SIMMER) controls power to the heating element. The unit also has two rocker switches for adding water to the unit. The FAUCET switch opens a normally closed solenoid valve to add water through a swing-away faucet. The SKIM switch opens a normally closed solenoid valve to add water through a spray nozzle mounted on the front of the cookpot. The skim feature sprays water onto the surface of the water, forcing starch to the overflow drain. This eliminates loss of cooking time associated with removing excess starch buildup. The cookpot is safeguarded against over filling and boilover by a large overflow drain. “SD” following the model designation indicates a stainless steel cookpot and door, and an enameled cabinet. “SC” following the model designation indicates all stainless steel components.

EWBS: The EWBS series replaced the ESW series. Models feature a 13-kilowatt heating element in a 16.5-gallon (62.5-liter) cookpot. The control options available include an operating thermostat and switch panel (identical to that on the ESW, described on the

previous page) or a specially modified CM III computer. The equipment may be configured as single cooker (E1WBS) or as a battery of two cookers (E2WBS). “SD” following the model designation indicates a stainless steel cookpot and door, and an enameled cabinet. “SC” following the model designation indicates all stainless steel components. Optional features include automatic water filling and a manual skim feature. Standard safety features on both models include a low-water safety shutoff and a water pressure regulator. All units may be configured with either a “Sauce Package” consisting of a saucepan insert rack, a sauce bag rack, and a rack cover, or with a “Pasta Package” consisting of a bulk basket, portion cups and cup rack, and a strainer board. Both models may be equipped with an optional swing-away faucet. The cookpot on both models is safeguarded against over filling and boilover by a large overflow drain and a starch diverter.

1.4 Installation, Operating, and Service Personnel

Operating information for Frymaster equipment is intended for use by qualified and/or authorized personnel only, as defined in Section 1.5.

All installation and service on Frymaster equipment must be performed by qualified, certified, licensed, and or/authorized installation or service personnel, as defined in Section 1.5.

1.5 Definitions

QUALIFIED AND/OR AUTHORIZED OPERATING PERSONNEL

Qualified/authorized operating personnel are those who have carefully read the information in this manual and have familiarized themselves with the equipment functions, or who have had previous experience with the operation of the equipment covered in this manual.

QUALIFIED INSTALLATION PERSONNEL

Qualified installation personnel are individuals, or firms, corporations, or companies that, either in person or through a representative, are engaged in and are responsible for the installation of electrical appliances. Qualified personnel must be experienced in such work, be familiar with all electrical precautions involved, and have complied with all requirements of applicable national and local codes.

QUALIFIED SERVICE PERSONNEL

Qualified service personnel are those who are familiar with Frymaster equipment and who are authorized by Frymaster to perform service on Frymaster equipment. All authorized service personnel are required to maintain a complete set of service and parts manuals and to stock a prescribed minimum amount of Frymaster parts. ***Failure to use qualified service personnel will void the Frymaster Warranty on your equipment.*** A list of Frymaster Factory Authorized Service Centers (FASCs) was included with the equipment when it was shipped from the factory.

1.6 Shipping Damage Claim Procedure

Your Frymaster equipment was carefully inspected and packed before leaving the factory. The transportation company assumes full responsibility for safe delivery upon acceptance of the equipment for transport.

What to do if your equipment arrives damaged:

- 1. File a claim for damages immediately**, regardless of the extent of damages.
- 2. Inspect for and record all visible loss or damage** and ensure that this information is noted on the freight bill or express receipt and is signed by the person making the delivery.
- 3. Concealed loss or damage** that was unnoticed until the equipment was unpacked should be recorded and reported to the freight company or carrier **immediately** upon discovery. A concealed damage claim must be submitted within 15 days of the date of delivery. Ensure that the shipping container is retained for inspection.

**FRYMASTER DOES NOT ASSUME RESPONSIBILITY
FOR DAMAGE OR LOSS INCURRED IN TRANSIT.**

ELECTRIC COOKER MODELS 17EC, 17ECS, ESW AND EWBS

CHAPTER 2: INSTALLATION INSTRUCTIONS

2.1 General Installation Requirements

PROPER INSTALLATION IS ESSENTIAL FOR EFFICIENT, TROUBLE-FREE OPERATION OF YOUR COOKER. ANY UNAUTHORIZED ALTERATIONS MADE TO THIS EQUIPMENT WILL VOID THE FRYMASTER WARRANTY.

Upon arrival, inspect the cooker carefully for visible or concealed damage. (See **Shipping Damage Claim Procedure** in Chapter 1.)

NATIONAL CODE REQUIREMENTS

This equipment is to be installed in compliance with the Basic Plumbing Code of the Building Officials and Code Administrators International, Inc. (BOCA) and the Food Service Sanitation Manual of the U.S. Food and Drug Administration.

ELECTRICAL GROUNDING REQUIREMENTS

All electrically operated appliances must be grounded in accordance with all applicable national and local codes. A wiring diagram is located on the inside of the equipment door. Refer to the rating plate on the inside of the door for proper voltages.

FCC COMPLIANCE

The user is cautioned that any changes or modifications to Frymaster computers not expressly approved by the party responsible for compliance could void the user's authority to operate the equipment. Frymaster computers have been tested and found to comply with the limits for a Class A digital device, pursuant to Part 15 of the FCC rules. While these devices are verified as Class A devices, they have been shown to meet the Class B limits. These limits are designed to provide reasonable protection against harmful interference when the equipment is operated in a commercial environment. This equipment generates, uses, and can radiate radio frequency energy and, if not installed and used in accordance with the instruction manual, may cause harmful interference to radio communications. Operation of the equipment in a residential area is likely to cause harmful interference in which case the user will be required to correct the interference at his own expense.

If necessary, the user should consult the dealer or an experienced radio and television technician for additional suggestions.

The user may find the booklet "How to Identify and Resolve Radio-TV Interference Problems" helpful. It is prepared by the Federal Communications Commission and is available from the U.S. Government Printing Office, Washington, DC 20402, Stock No. 004-000-00345-4.

2.2 Caster/Leg Installation

Depending upon the specific configuration ordered, your unit might have been shipped without installed casters or legs. If casters or legs are installed, you may skip this section and proceed to Section 2.3, Pre-Connection Preparations.

If your unit requires the installation of casters/legs, install them in accordance with the instructions included in your accessory package.

2.3 Pre-Connection Preparations

After the unit has been positioned in the area where it will be used, ensure the following have been accomplished before connecting the unit to the electrical power source:

1. This equipment must be stabilized by installing restraining chains on units equipped with casters or anchor straps on units equipped with legs. Follow the instructions shipped with the casters/legs to properly install the chains or straps.
2. Level units equipped with legs by screwing the legs out approximately 1 inch, then adjusting them so that the unit is level.

For units equipped with casters, there are no built-in leveling devices. The floor where the unit is to be installed must be level.

3. Install the basket lift arms (on units so equipped) on the lift rods (located at the top rear of the cabinet) so that the basket lift rollers guides the lift arms.

NOTE: *Some adjustment of the rollers may be necessary for free movement of the basket lift arms.*

4. If so equipped, connect the water hose(s) to the fitting(s) at the rear of the unit and connect the unit to the water supply.

CAUTION

Incoming water pressure for all units should be approximately 40 PSI (28.15 kg/cm²).

DANGER

The maximum allowable incoming water pressure for all units is 80 PSI (56.3 kg/cm²).
The maximum allowable incoming water temperature for all units is 180°F (82°C).

WARNING

To prevent back flushing, the connection piping should be installed with a vacuum breaker or means of providing an air gap 1" (2.54 cm) above the cookpot rim.

NOTE: *On units equipped with water hoses, the hoses come with a quick-disconnect coupling. The quick disconnect may be attached to the unit or to the water supply line, or it may be left off entirely, whichever you prefer. If the unit is to be moved frequently (for cleaning or preventive maintenance), Frymaster recommends installing flexible water lines. If the cooker is hard-plumbed then moved, the connections may loosen and eventually cause leaks.*

Whichever option is chosen, Teflon thread-seal tape, Loctite™ PST56765 or equivalent thread sealer must be used when installing the fittings.

NOTE: Depending on specific model ordered, either hot or cold water, or both, may be connected to the unit. If available, connecting hot water will minimize the time required to bring the unit to a boil when filling with fresh water.

NOTE: In order for the water level sensors to work properly, a certain amount of mineral content is necessary in the water. For that reason, purified, deionized, or highly filtered water should not be used.

5. Connect the desired drain plumbing to the drain valve.

2.4 Connecting to the Electrical Supply

DANGER

This unit must be connected to the voltage and phase specified on the rating and serial number plate located on the inside of the equipment door. To determine the appropriate wire size, refer to the **POWER REQUIREMENTS** chart at the bottom of this page.

1. If the unit is not equipped with an installed power cord, open the door and remove the contactor box cover. Position the unit to gain access to the rear and remove the lower back panel.
2. Insert an appropriately rated power cord into the rear of the contactor box and make connections in accordance with the applicable wiring diagram on the following page. Install a strain relief on the power cord and replace the lower back panel and contactor box cover.
3. Attach a plug that complies with national and/or applicable local codes to the free end of the electrical power cord and plug the unit into an appropriate outlet.

POWER REQUIREMENTS				
Use copper wire ONLY, suitable for at least 170°F (75°C)				
ELECTRIC COOKER MODELS 17EC, 17ECS, ESW, & EWBS				
Volts	Phase	Watts	Amps (per leg)	Minimum Wire Size
200	Single	7860	40	AWG 6 (4.1 mm)
200	Single	12000	60	AWG 4 (5.2 mm)
208	Single	8500	41	AWG 6 (4.1 mm)
208	Single	13000	63	AWG 4 (5.2 mm)
208	3P – Delta	8500	48	AWG 8 (3.3 mm)
200	3P – Delta	12000	35	AWG 6 (4.1 mm)
208	3P – Delta	13000	37	AWG 6 (4.1 mm)
230	3P – Delta	13000	33	AWG 6 (4.1 mm)
200	3P – Wye	12000	21	AWG 8 (3.3 mm)
230	3P – Wye	13000	19	AWG 8 (3.3 mm)

FIELD CONNECTION WIRING DIAGRAMS

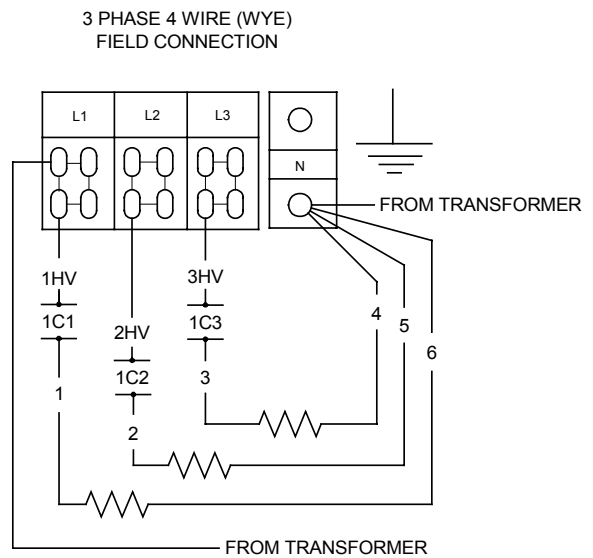
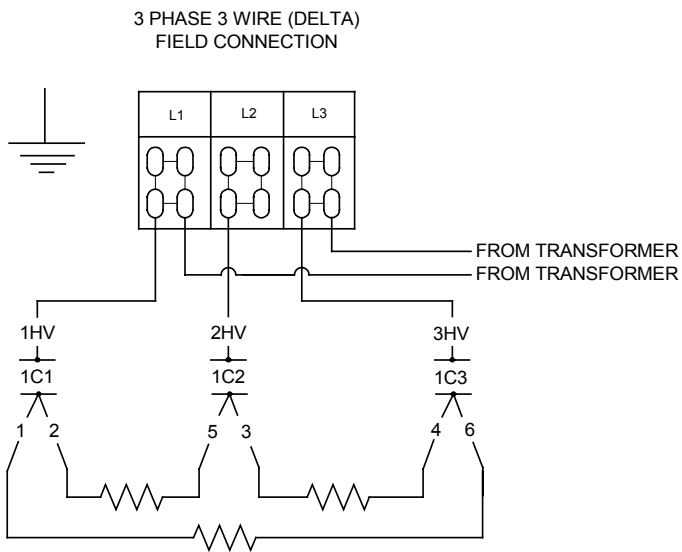
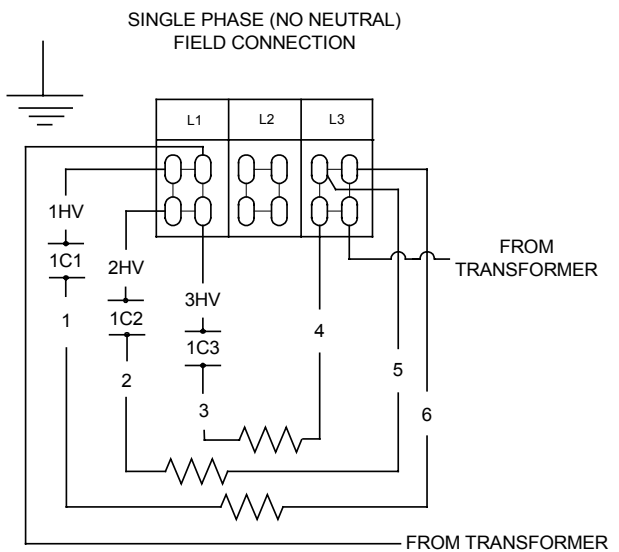
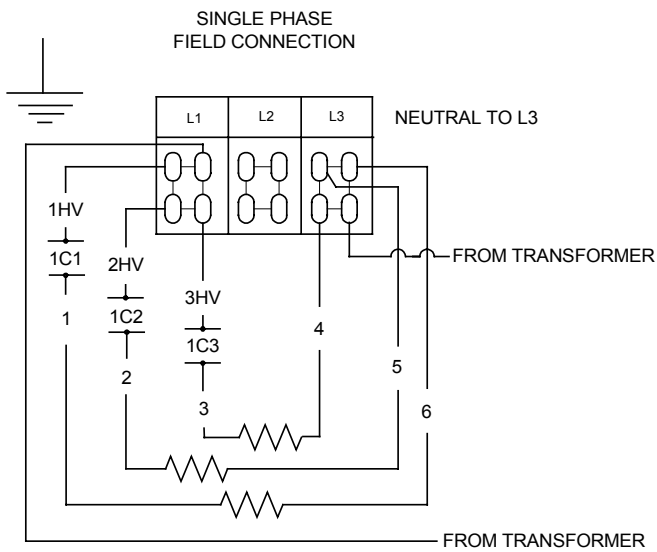

ELECTRIC COOKER MODELS 17EC, 17ECS, ESW AND EWBS

CHAPTER 3: OPERATING INSTRUCTIONS

3.1 Spaghetti Magic III Controller (As Used on 17EC and 17ECS Units)

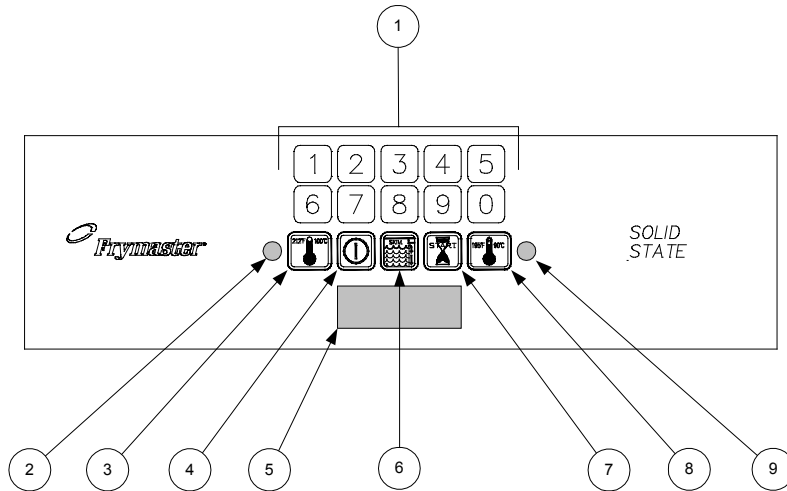

1	Numeric Keypad	6	Skim Switch (w/Autoskim only)
2	Boil Mode Indicator	7	Timer Start Switch
3	Boil Mode Switch	8	Simmer Mode Switch
4	Power Switch	9	Simmer Mode Indicator
5	LED Display		

3.1.1 Introduction

CAUTION

The Spaghetti Magic III (SMS III) computer used in 17EC/17ECS units is specially configured for them. The programming and operation of the 17EC/17ECS SMS III computer are different than those of the SMS III computers used in other products.

The computers are not interchangeable.

The Spaghetti Magic III computer allows the operator to specify a specific cook time in minutes and seconds, then initiate a cooking cycle. The computer is configured for both automatic filling (AutoFill) and automatic skimming (Autoskim) features.

The **BOIL** mode is used when actually cooking pasta.

The **SIMMER** mode feature maintains the water temperature just below boiling (approximately 195°F/90.6°C), which conserves energy and water. This feature is designed for rethermalizing previously cooked packaged products, and for keeping the cooker in standby.

The **SKIM** feature, when selected, adds water for approximately 3 seconds once a minute. It causes the water to overflow into the drain, carrying floating starch with it. (A buildup of starch reduces the efficiency of the cooker and can cause erroneous temperature and water level sensing.)

LOW WATER SENSING automatically de-energizes the heating element if the water in the cookpot drops too low. When the water level in the cookpot is below the sensor probes, such as when draining and cleaning the cookpot, the controller display will read **LO**.

NORMAL WATER LEVEL SENSING, on units configured with the AutoFill feature, automatically adds water during or after a cooking cycle if the water level is low. With this automatic filling feature, the water level does not have to be continuously monitored. The cookpot always has the correct amount of water.





3.1.2 Operating Instructions

CAUTION

If this is the first time the unit is being used after installation, refer to **Section 3.4, Boil Out Procedure**.

Before turning the cooker on, ensure that:

- the unit is connected to the water supply.
- the water supply is turned on.
- the unit is plugged into an appropriate outlet.
- the electrical power supply is turned on.

1. Turn the controller on by pressing the Power  switch.
2. The unit will automatically enter the simmer mode and the simmer mode indicator will illuminate. This will bring the cooker to “stand-by” temperature. To enter the boil mode, press the Boil Mode  switch.
3. Enter the desired cooking time using the numeric keypad. The time entered appears in the LED display.
4. When ready to initiate a cooking cycle, press the Start Timer  switch then press the Boil Mode  switch. The basket lift will automatically lower the basket or portion cups into the cookpot and the LED display will begin to count down. Simultaneously, the water will be raised to the boiling point. At the end of the cooking cycle, an alarm will sound briefly to alert you and the basket lift will automatically raise the basket or portion cups out of the water.
5. The display will automatically return to the previously set cooking time and the unit will return to the simmer mode. If the same time is desired for the next batch, simply repeat Step 4. If a different cooking time is desired, follow Steps 3 and 4.
6. To initiate the automatic skimming (Autoskim) feature, press the Skim  switch.

3.1.3 Setting the Controller Transition Temperature/Boil Intensity

You may adjust the cooker’s Transition Temperature/Boil Intensity to prevent boilover on controllers configured with this feature.

When the water is at or above the minimum temperature for boiling (transition temperature), the controller pulses power to the elements at a programmable rate. The range can be set between 0 and 9. The default setting is 5. When the water temperature is below boiling point, the power application is 100 percent.

To set the Transition Temperature/Boil Intensity:

1. Verify that the controller is OFF (the display is blank).
2. Press the Simmer (right thermometer icon) switch to enter the programming mode; *CODE* appears in the display.
3. Enter code 1111 (press the 1 button four times). *TRANSITION TEMPERATURE* appears in the display. **(NOTE:** If *TRANSITION TEMPERATURE* does not appear, your controller is not configured with this feature. Press the Simmer switch to exit the programming mode. The display will go blank.)
4. Enter the minimum temperature for boiling with the keypad. This temperature will vary with your altitude. As a guide, the table below provides boiling points for altitudes from sea level to 6000 feet (1830 meters).

Altitude		Boiling Point	
Feet	Meters	°F	°C
0	0	212	100
1000	305	210	99
2000	610	208	98
3000	915	207	97
4000	1220	205	96
5000	1525	203	95
6000	1830	201	94

5. Press the simmer switch; *5BI* (the default setting for boil intensity) appears.
6. Use the keypad to enter one of the settings from the table below.

Setting	Power ON	Power OFF
0	100%	0%
9	90%	10%
8	80%	20%
7	70%	30%
6	60%	40%
5	50%	50%
4	40%	60%
3	30%	70%
2	20%	80%
1	10%	90%

7. Press the simmer switch to lock in the new settings and exit the programming mode. The display will go blank.

3.1.4 Controller Simmer Mode Adjustment

NOTE: The SMS III Controller simmer temperature is adjustable from 185°F to 215°F (85° to 102°C). There are two versions of this controller; one is adjusted by programming, the other is manually adjusted.



To determine which version of the controller you have, turn the controller off by pressing the ON/OFF switch. The display will go blank. Press the Simmer (right thermometer icon) switch. If **Code** appears in the display, the simmer mode setpoint is changed via programming; if not, skip to **Manual Adjustment** below.

1. Press 1, 6, 5, 0 to enter the programming mode. The currently programmed simmer setpoint will be displayed. If the setpoint is **not correct**, enter the desired setpoint (for example, press 2, 0, 0 to program the simmer setpoint to 200°).
2. Press the Simmer switch again to lock in the setpoint, then press the ON/OFF switch to turn the controller on and return to the normal operating mode.

Manual Adjustment

1. With the unit in the simmer mode, place the tip of a good grade thermometer near the temperature probe and determine the actual water temperature in degrees Fahrenheit. If the temperature is within 5°F (2°C) of the desired simmer temperature, nothing more needs to be done. If it is not within 5°F (2°C) of the desired temperature, perform Steps 2 through 5.
2. With the unit in the simmer mode, open the control panel by removing the screws in the upper corners and tilting the panel out.
3. Remove the black rubber plug from the top of the controller housing.
4. Using a small, flat-tipped screwdriver, turn the adjusting screw to change the simmer setpoint. ¼ turn will change the setpoint about 10°F (5°C). (You will have to experiment with the direction of rotation to determine which way to turn to raise or lower the temperature.) Wait at least 5 minutes, then recheck actual water temperature. Repeat this step until the water temperature is within 5°F (2°C) of desired temperature.
5. Replace the plug in the controller, close the control panel, and replace the screws removed in Step 1.

3.1.5 Toggling Between Fahrenheit and Celsius Temperature Display

1. There are two versions of the SMS Controller: one that can be toggled between Fahrenheit and Celsius temperature display and one that cannot. To determine which version you have, turn the controller off by pressing the Power  switch. The display will go blank. Press the Simmer  switch. If **Code** appears in this display, the temperature display can be changed. If not, the display cannot be changed.
2. If **Code** appears in the display, press 1, 6, 5, 8. The display will toggle from Fahrenheit to Celsius, or from Celsius to Fahrenheit.

Press the Boil Mode  switch to display the cookpot temperature. If an **F** follows the temperature, the display is in Fahrenheit; if a **C** follows the temperature, the display is in Celsius.

3.1.6 Shutting the 17EC/17ECS Down

Turn the unit off by pressing the Power  switch. If shutting down at the end of the day, drain and clean the cookpot, and put the cookpot cover in place.

3.2 Computer Magic III Controller (As Used on EWBS Units)

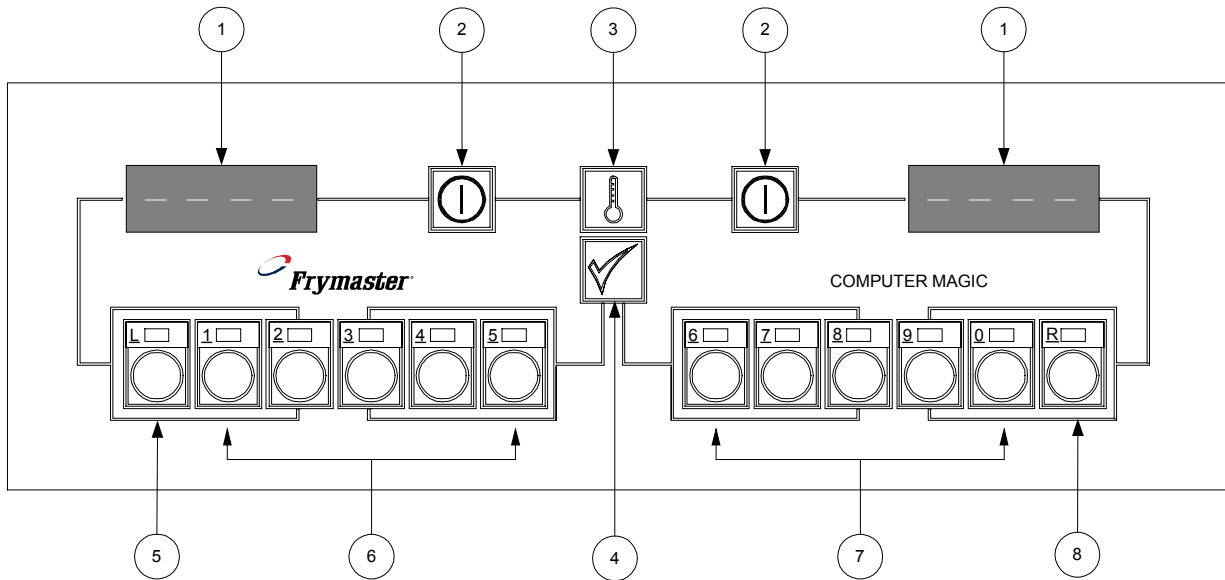

1	LED Displays	5	Boil Mode Switch
2	Power Switches	6	Product Buttons 1 through 5
3	Temperature Check/Program Lock	7	Product Buttons 6 through 10
4	Program Mode Switch	8	Simmer Mode Switch

CAUTION

The Computer Magic III (CM III) computer used in Electric Water Bath Systems is specially configured for them. The programming and operation of the EWBS CM III are different than those of the CM III computers used in electric fryers.

The two computers are not interchangeable.

3.2.1 Start-Up Procedure

CAUTION

If this is the first time the unit is being used after installation, refer to **Section 3.4, Boil Out Procedure.**

SETTING THE UNIT UP FOR FIRST-TIME OPERATION



Before turning the cooker on, ensure that:

- the unit is connected to the water supply.
- the water supply is turned on.
- the unit is plugged into an appropriate outlet.
- the electrical power supply is turned on.



CAUTION





It is recommended that the simmer setpoint and the cook/stir times for all 10 products be programmed before the unit is first used in a cooking cycle.

When the unit is tested at the factory, the simmer setpoint and product cook times are programmed. These *test* settings are **not** default settings. You must program the unit for your own particular products. Program the setpoint and all 10 product cook/stir times as follows:

1. Turn the computer on by pressing the Power  Switch.
2. Enter the programming mode by pressing the Program Mode Switch . **CodE** appears in the left display. If you enter the programming mode by mistake, press the switch again to exit the programming mode.

NOTE: *If you try to enter the programming mode while the computer is cooking, the display will flash **BUSY**.*

NOTE: *The unit comes from the factory configured to display in degrees Fahrenheit. To toggle back and forth between Fahrenheit and Celsius, press the Program Mode  switch, then enter the code **1 6 5 8** by pressing the corresponding product buttons. Next, press the Temperature Check/Program Lock  switch to lock in the new display option.*

3. Enter the number **1 6 5 0** by pressing the corresponding product buttons. Unless this code is entered, programming will not be accepted. This is to prevent unauthorized changes to your current instructions.
4. **SP-r** (Setpoint) will appear in the left LED display. Any previously programmed temperature setpoint will appear in the right display. To change the setpoint, enter the desired setpoint temperature using the corresponding product buttons. The setpoint can be programmed for any value up to 212°F (100°C). Press the Program Mode  switch to lock in the new setpoint (or the old setpoint, if it was not changed).
5. **SELP** (Select Product) will appear in the left display. Press the product button to be programmed (or press  to return to the normal operating mode).
6. **COOC** (Cook Time) will now show in the left display. Any previously programmed cooking time will appear in the right display. Pressing  will accept the current cooking time. To change the cooking time, enter the new time using the product buttons. The cook time can be programmed up to 59:59. Press  to lock in the new time.

NOTE: *The computer can be programmed for either “standard” or “slow” clock speed. The standard clock displays minutes and seconds, the slow clock displays hours and minutes. To toggle back and forth between clock speeds, press the Program Mode switch, then enter the code 1 6 5 3 using the product buttons.*

To determine if the clock speed is set to standard or slow, initiate a cook cycle by pressing a product button. If the computer is set to the standard clock, the time in the LED display will immediately begin to count down. If it does not, the computer is set to the slow clock.

7. **Sh1** (Stir Time 1) appears in the left display. If your product requires stirring during the cooking process, set the number of seconds to cook before stirring using the product buttons. If your product does not require stirring, enter “0”. The number entered will appear in the right display. The stir time can be programmed up to 59:59, **but cannot exceed the product cook time**. Press to lock in the programmed time.

Sh2 will appear. Program the time of the second stir time as above. Be sure the time entered is greater than **Sh1** or else is “0”.

Sh3 will appear. Program the length of the third stir time in the same manner as for Stir Times 1 and 2. Be sure that the time entered is greater than **Sh2** or else is “0”.

For example, entering “30” means the product needs to be stirred after it has been cooking for thirty seconds. At the end of thirty seconds, an alarm will sound and the product switch will flash until cancelled by the operator pressing the product button.

 **CAUTION**

Remember: **Sh2** must be greater than **Sh1** (or else be “0”). **Sh3** must be greater than **Sh2** (or else be “0”). None of the stir times can be greater than the cook time entered in Step 6.

8. **SELP** (Select Product) will again appear in the left display. If more products are to be programmed, follow Steps 5 through 8 for each additional product.
9. When you complete your programming, lock in the whole program by pressing the Temperature Check/Program Lock Switch .

3.2.2 Operating the Computer

Turn the computer on by pressing the Power switch. **NOTE:** *A decimal between digits 1 and 2 in either LED Display indicates the unit is heating.*

1. One of the following will normally be displayed:
 - a. **°-Lo**, indicating that the water temperature is 11°F (6°C) lower than the setpoint.
 - b. “- - -” indicating that the water temperature is in the cooking range. **NOTE:** *For best results, cooking should not be attempted unless the display indicates “- - -”.*

NOTE: You may also see one of these indicators of **abnormal** operation:

- **°-Hi**, indicating that the water temperature is 11°F (6°C) higher than the setpoint
- **HELP**, indicating a heating problem.
- **Prob**, indicating that the computer temperature probe circuit is open.

2. Press a product button to start a cook cycle.

- a. The programmed cook time will appear and the countdown begins.
- b. If stir times are programmed, the operator will be notified to agitate the product a predetermined number of seconds after the cook cycle has begun. An alarm will sound, the display will read **Stir**, and the LED in the product button will blink. To cancel the alarm, press the indicated product button.



If no stir times have been programmed, **Stir** will not appear during the cook cycle.

 **CAUTION**

Pressing the product button twice while the **Sh** alarm sounds will cancel the cook cycle as well as the alarm.

- c. At the end of the cook cycle, an alarm will sound, **COOC** will be displayed, and the associated product button will flash. To cancel the alarm, press the flashing button.
3. To check the frypot temperature at any time, press the Temperature Check  switch once. To check the setpoint, press the switch twice. If you suspect the temperature probe is defective, check the temperature of the cookpot with a thermometer or pyrometer to verify that the computer readout is reasonably close to the measured reading.
4. During idle periods when the cooker is on but not in use, “- - -” should appear in both displays, indicating that the cookpot is at setpoint. If not, check the actual temperature and setpoint.

SELECTING FAHRENHEIT– CELSIUS DISPLAY MODE

1. The computer can display temperatures in either Fahrenheit or Celsius. To change from one to the other, press the Program Mode Switch . **Code** will appear in the left display.
2. Enter the code number **1 6 5 8** on the number keypad. The computer will toggle the temperature display from Celsius to Fahrenheit or from Fahrenheit to Celsius.
3. Press the Temperature Check/Program Lock Switch  to display the temperature in the newly selected mode.

SELECTING STANDARD OR SLOW CLOCK

The computer can be programmed for either “standard” or “slow” clock times. The standard clock displays minutes and seconds, the slow clock displays hours and minutes.

To toggle back and forth between times press the Program Mode switch, then enter the code **1 6 5 3** using the product buttons.

SELECTING BOIL OR SIMMER MODE

In the **SIMMER** mode, the water temperature is maintained at the setpoint programmed by the operator. In the **BOIL** mode, the water temperature is raised to 212°F (100°C).

Select the **SIMMER** mode by pressing the button. If the temperature of the water is above the setpoint, **°-hi** will be displayed. If the temperature of the water is below the setpoint, **°-lo** will be displayed. If the temperature is within 11°F (6°C) of the setpoint, “- - - -” will be displayed.

The **BOIL** mode is selected by pressing the button. The display will show *boil* and the temperature of the water will be raised to 212°F (100°C).

3.2.3 Shutting the EWBS with CM III Computer Down

Turn the unit off by pressing the Power switch.

If shutting down at the end of the day, drain and clean the cookpot, and put the cookpot cover in place.

⚠ CAUTION

The electronic circuitry in your computer can be affected adversely by power fluctuations and electrical storms. If it fails to function or program properly for no apparent reason, try unplugging the computer from the interface board and plugging it back in. This could prevent a service call.

3.3 Thermostat Control and Switch Panel (Used on ESW and EWBS Units)

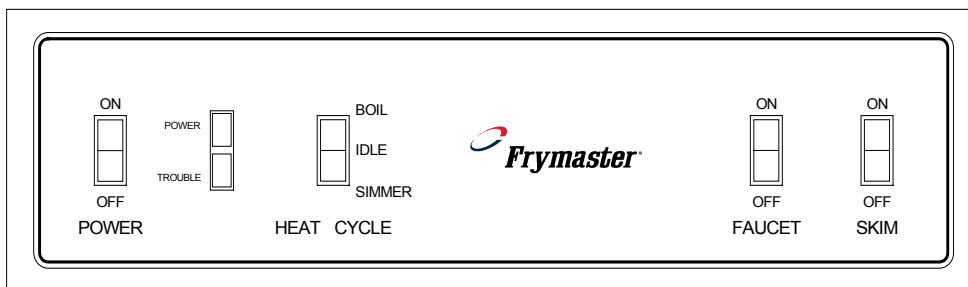

SWITCH PANEL

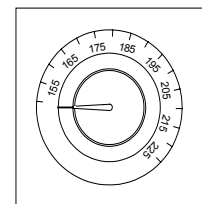

THERMOSTAT CONTROL

⚠ CAUTION

If this is the first time the unit is being used after installation, refer to **Section 3.4, Boil Out Procedure.**

On ESW units and EWBS units without CM III computers, a thermostat located inside the door maintains the simmer mode temperature. Rocker switches on the control panel turn the power on and off, control the heat cycle, and add water.

When the Power switch is placed in the ON position, the white power indicator will illuminate. If the unit is equipped with the AutoFill feature and the water level in the cookpot is below the upper water level sensor, the cookpot will immediately begin to fill with water. If the Heat Cycle switch is in the ON or SIMMER position, the heating element will energize as soon as the lower water level sensor is covered with water. Illumination of the red trouble light at anytime indicates that the high-limit safety has tripped. ***If the red trouble light illuminates, place the Power switch in the OFF position immediately.***

When the Heat Cycle switch is placed in the IDLE position, the heating element is de-energized, but power to the Faucet and Skim switches is maintained. Placing this switch in the SIMMER position maintains the water at the temperature indicated on the thermostat control dial. The switch is placed in the BOIL position for cooking product or reheating packaged sauces. A built in low-water safety feature prevents the heating element from being energized unless the lower water level sensor is covered with water, regardless of the position in which the switch is placed.

On units with the AutoFill feature, placing the Power switch to the ON position activates the feature, causing the water solenoid valve to open, adding water to the cookpot until the water level reaches the upper water level sensor. When the water reaches the upper sensor, the valve closes. As long as the switch is in the ON position, whenever the water level drops below the upper water level sensor, water will be automatically added to the cookpot. If the switch is placed in the OFF position, the AutoFill feature is disabled. On units without AutoFill, the cookpot must be manually filled by placing the faucet switch in the ON position. The switch must be placed in the OFF position to stop the water flow.

The Skim switch allows the operator to add water to the cookpot during the cooking cycle. This causes any accumulation of starch floating on the surface of the water to be washed down the overflow drain. Water will be added as long as the switch is in the ON position.

Turn the unit off by placing the Heat Cycle switch in the IDLE position and the Power switch in the OFF position. If shutting down at the end of the day, drain and clean the cookpot, and put the cookpot covers in place.

3.4 Boiling Out the Cookpot

The cookpot must be boiled out before first use.

1. Close the drain valve and fill the cookpot with a mixture of cold water and 1 cup of detergent.
2. Place the unit into operation. (See Section 3.1.2 for 8SMS, 8BC or 8C units. See Section 3.2.2 for EWBS units.)
3. Press the simmer switch,  on 8SMS, 8BC and 8C units or **R** on EWBS units, and allow the solution to simmer for at least 1 hour.

4. After the solution simmers for 1 hour, turn the unit off and add cold water until the solution is cool. Drain the solution and clean the frypot thoroughly. Rinse the cookpot at least twice by filling with clean water and draining. Dry the cookpot thoroughly with a clean, dry towel.

THIS PAGE INTENTIONALLY LEFT BLANK.

ELECTRIC COOKER MODELS 17EC, 17ECS, ESW AND EWBS

CHAPTER 4: PREVENTIVE MAINTENANCE

Daily Preventive Maintenance

It is normal for a coating of starch to form on the elements, sensors, and temperature probes during operation. If the coating is allowed to build-up, it will adversely affect the operation of the equipment. The preventive maintenance routines below should be performed at least daily to keep your equipment functioning at peak efficiency.

Inspect Equipment and Accessories for Damage

Look for loose or frayed wires and cords, leaks, foreign material in cookpot or inside cabinet, and any other indications that the equipment and accessories are not ready for safe operation.

Clean Cabinet Inside and Out

Clean inside the cabinet with a dry, clean cloth. Wipe all accessible metal surfaces and components to remove accumulations of oil, dust, or cooking residue.

Clean the outside of the cabinet with a clean cloth dampened with dishwashing detergent, removing oil, dust, or cooking residue.



Never attempt to clean this equipment during the cooking process or when the cookpot is filled with hot water and/or food products.

Clean Water-Level Sensors, Temperature Sensor, Element, and Cookpot

Turn the equipment off and drain the cookpot.

Clean the water level sensors (located in the front of the cookpot behind the sensor cover). Normally, a bottlebrush and a solution of detergent and water may be used to clean the sensors with the cover installed. If the sensors become coated with an unusually heavy layer of starch or lime, the cover may be removed to better access the sensors for cleaning using a Scotch-brite™ or similar abrasive pad and a solution of detergent and water.

Using a Scotchbrite™ or similar abrasive pad and a solution of detergent and water, clean the inside of the cookpot. Pay particular attention to the heating element.

Rinse the cookpot thoroughly with clean water at least twice.

THIS PAGE INTENTIONALLY LEFT BLANK.

ELECTRIC COOKER MODELS 17EC, 17ECS, ESW AND EWBS

CHAPTER 5: OPERATOR TROUBLESHOOTING

5.1 Introduction

This chapter provides an easy reference guide to the more common problems that may occur during the operation of this equipment. The troubleshooting guides in this chapter are intended to help you correct, or at least accurately diagnose, problems with the equipment. Although the chapter covers the most common problems reported, you may very well encounter a problem not covered. In such instances, the Frymaster Technical Service Department will make every effort to help you identify and resolve the problem.

When troubleshooting a problem, always use a process of elimination starting with the simplest solution and working through to the most complex. Never overlook the obvious. Anyone can forget to plug a cord into a receptacle or open the valve on the water supply line. Don't assume that you are exempt from such occurrences. Most importantly, try to establish a clear idea of why a problem has occurred. Part of your corrective action involves taking steps to ensure that it doesn't happen again. Keep in mind that failure of a small component may often be indicative of potential failure or incorrect functioning of a more important component or system.

Some of the troubleshooting actions recommended in this chapter involve removing suspect controllers and substituting controllers that are known to be good, if they are available. Whenever this is indicated, refer to Section 5.3. Refer to Section 5.4 for instructions on replacing fuses in 17EC and 17ECS models.

If the troubleshooting and corrective actions in this chapter do not solve the problem, the problem is probably beyond the scope of most operators to solve and you should call your FASC for assistance. If you have doubts as to the proper action to take, do not hesitate to call the Frymaster Technical Service Department or your local Frymaster Factory Authorized Service Center for assistance.

Before calling a servicer or the Frymaster HOTLINE (1-800-551-8633):

- **Verify that electrical cords are plugged in and that circuit breakers are on.**
- **Verify that water supply valves are open and that drain valves are fully closed.**

 **DANGER**

Hot water can cause severe burns. Never attempt to move a cooker containing hot water or to transfer hot water from one container to another.

 **DANGER**

Use extreme care when performing electrical circuit tests. Live circuits will be exposed.

 **WARNING**

Inspection, testing, and repair of electrical components should be performed only by qualified service personnel. The equipment should be unplugged when servicing, except when electrical tests are required.

5.2 Operator Troubleshooting Guide

PROBLEM	PROBABLE CAUSES	CORRECTIVE ACTION
Controller does not activate.	A. No power to unit.	A. Turn on circuit breaker.
	B. Master Power switch in OFF position (17EC and 17ECS models only).	B. Place Master Power switch in ON position.
	C. Controller not turned on.	C. Push power switch.
	D. Blown fuse (17EC and 17ECS models only).	D. Replace fuse (see Section 5.4)
Autofill does not add water.	A. Water not turned on.	A. Turn water on.
	B. Defective controller.	B. Replace controller (see Section 5.3).
Autofill does not shut off when the cookpot is full.	A. Dirty upper water level sensor.	A. Clean sensor.
	B. Insufficient mineral content in water.	B. Add 1/8-cup baking soda to cookpot.
	C. Defective controller.	C. Replace controller (see Section 5.3).
Water will not heat (controller is on, water is at normal level, but LO is not showing on the controller).	A. Dirty low water level sensor.	A. Clean sensor.
	B. Insufficient mineral content in water.	B. Add 1/8 cup baking soda to cookpot.
	C. Defective controller.	C. Replace controller (see Section 5.3).
Water will not heat (water above lower water level sensor and LO is showing on the controller).	Defective controller.	Replace controller (see Section 5.3).
Water heats but does not boil.	Defective controller.	Replace controller (see Section 5.3).
Water boils in simmer mode.	Controller out of adjustment.	Adjust controller in accordance with Section 3.1.3 (17EC/17ECS) or 3.2.2 (EWBS).
Water temperature is too low in simmer mode.	Controller out of adjustment.	Adjust controller in accordance with Section 3.1.3 (17EC/17ECS) or 3.2.2 (EWBS).
Timer does not count down.	A. Operator error.	A. Push timer start switch (17EC/17ECS) or a product button (EWBS with CM III controller).
	B. Defective controller.	B. Replace controller (see Section 5.3).

Troubleshooting Guide (Continued)

PROBLEM	PROBABLE CAUSES	CORRECTIVE ACTION
Autoskim does not add water (Autofill operating correctly)	Defective controller.	Replace controller (see Section 5.3).
Basket Lift does not function correctly.	A. Blown fuse (17EC and 17ECS models only).	A. Replace fuse (see Section 5.4)
	B. Roller jammed.	B. Adjust roller.
	C. Lifter rod jammed.	C. Check for free movement. Lubricate with white grease.
	D. Defective controller.	D. Replace controller (see Section 5.3).
	E. Loose or misadjusted microswitch.	E. Check switch adjustment. Adjust as required.

5.3 Replacing the Controller (17EC/17ECS and EWBS with CM III Computer)

1. Disconnect the cooker from the electrical supply.
2. Remove the two screws in the upper corners of the control panel and swing the panel open from the top, allowing it to rest on its hinge tabs.
3. Disconnect the wiring harness from the back of the controller.
4. Disconnect the ground wire from the controller. Remove the controller by lifting it from the hinge slots in the frame.
5. Reverse the procedure to install a new controller.

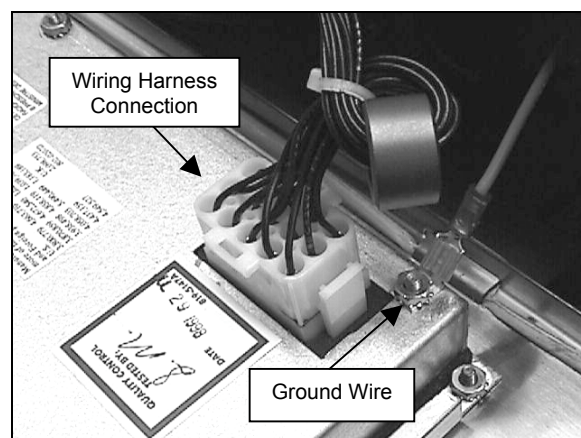

5.4 Replacing Fuses in 17EC and 17ECS Models

1. Disconnect unit from electrical power and remove the cover from the contactor box.
2. The 5-amp fuses are located on the left side of the box. The fuse for the controller is located nearest the front of the box. Use a fuse puller to remove the blown fuse and install the replacement.

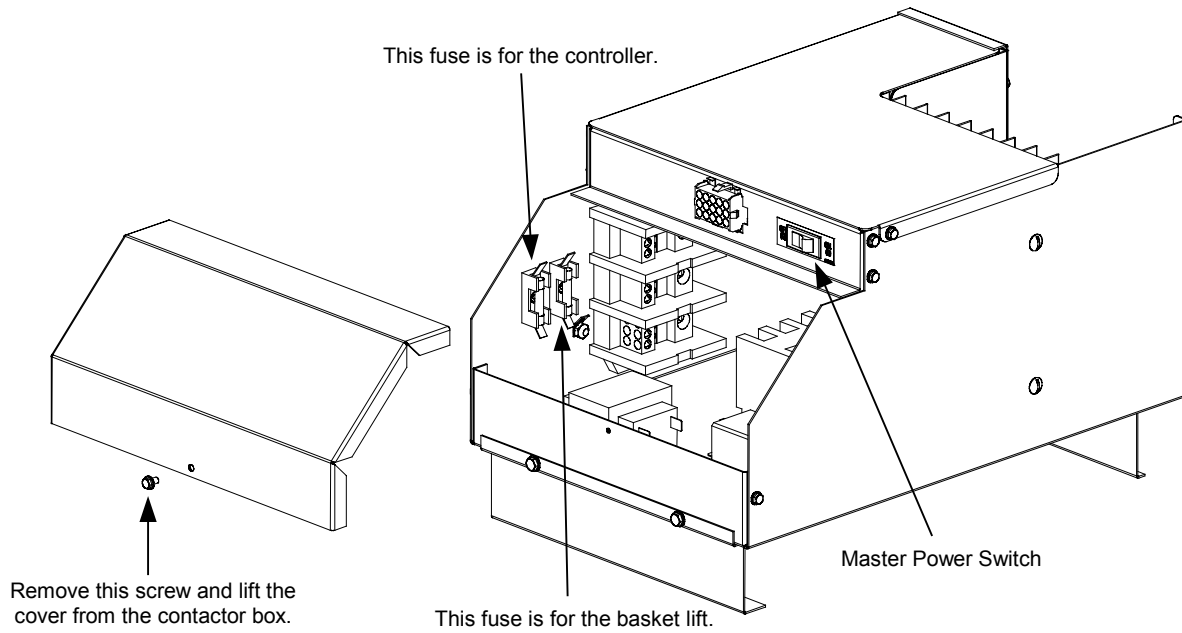

3. Replace the component box cover, and reconnect the unit to the electrical power supply.

ELECTRIC COOKER MODELS 17EC, 17ECS, ESW AND EWBS

CHAPTER 6: 17EC/17ECS SERVICE PROCEDURES & PARTS

6.1 Functional Description

The 17EC Electric Cooker contains a 16.5-gallon (62.5-liter) stainless steel cookpot. The water in the cookpot is heated by a pair of 8.5-kilowatt heating elements. Electrical power to the elements is controlled by a solid-state SMS III *Spaghetti Magic* computer specifically modified for this application. **NOTE:** The SMS III computer used in the 17EC is identical in appearance to the SMS III computers used in other model lines, but differs internally. *Use only P/N 106-0385 SMS III computers on this equipment.* The 17EC is equipped with a basket lift, and also features automatic filling (AutoFill) and automatic skimming (AutoSkim). This model also has a swing-away jointed faucet. The 17ECS model has an attached 16.5-gallon (84.1-liter) rinse tank.

Turn the Master Power Switch ON and press the computer Power switch. A logic circuit checks the water level by looking for a ground at the upper water-level sensor. A normally closed solenoid valve opens if no ground is seen, indicating water is below the sensor, and water enters the cookpot. The unit enters the Simmer mode when the heating elements are covered (indicated by grounding of the low-water sensor). The cookpot continues to fill until water reaches the upper water-level sensor and the solenoid closes. The cooker stays in Simmer mode until the Boil mode switch is pressed or the unit is turned off. The water solenoid valve opens anytime the water level is below the upper water-level sensor.

Logic circuits in the computer monitor the temperature and cycle power on and off to maintain the simmer setpoint. (See Chapter 3 for instructions on adjusting the setpoint.) The cooker also has a high-limit safety. If the cookpot fails to refill and the water level drops below the low-water sensor, the high-limit will open, cutting off power to the elements, when the element temperature reaches $400 \pm 15^{\circ}\text{F}$.

Pressing the Skim switch activates the AutoSkim feature. A logic circuit in the computer opens the solenoid valve in the water supply line for three seconds every minute until the option is turned off by again pressing the Skim switch.

The operator enters a cooking time by pressing the number pads on the computer. The computer counts down the cook cycle time when the Start switch is pressed. When the computer times out, an alarm sounds briefly, then the timer reverts to the last time entered.

Logic circuits in the computer also activate the basket lift motors when the Start switch is pressed, lowering the basket into the cookpot. A pair of motors drive the basket lift arms down until a cam attached to the left motor loses contact with a roller-activated microswitch and power to the motors is cut. When the computer times out, the logic circuits reverse the switch positions so that the motor circuit is again completed and the motors are restarted, raising the basket from the cookpot. The cam again makes contact with the microswitch at the raised position, cutting power to the motors and stopping the lift in the up position.

6.2 Accessing Equipment for Servicing

DANGER

Moving this equipment while it is filled with hot water may cause spilling or splattering of the hot water. Always drain the cookpot before attempting to relocate this equipment for servicing.

1. Disconnect the unit from the electrical power supply and from the water supply.
2. Remove any attached restraining devices.
3. Relocate the unit for service accessibility.
4. After servicing is complete, reconnect the unit to the water supply, reattach restraining devices, and reconnect the unit to the electrical power supply.

6.3 Replacing Equipment Components

6.3.1 Replacing the Computer

See Section 5.3.

6.3.2 Replacing Electronic Components Other than the Computer

1. Drain the cookpot and disconnect the cooker from the electrical power supply.
2. Remove the covers from the component box. Refer to the illustration below to locate the component to be replaced.

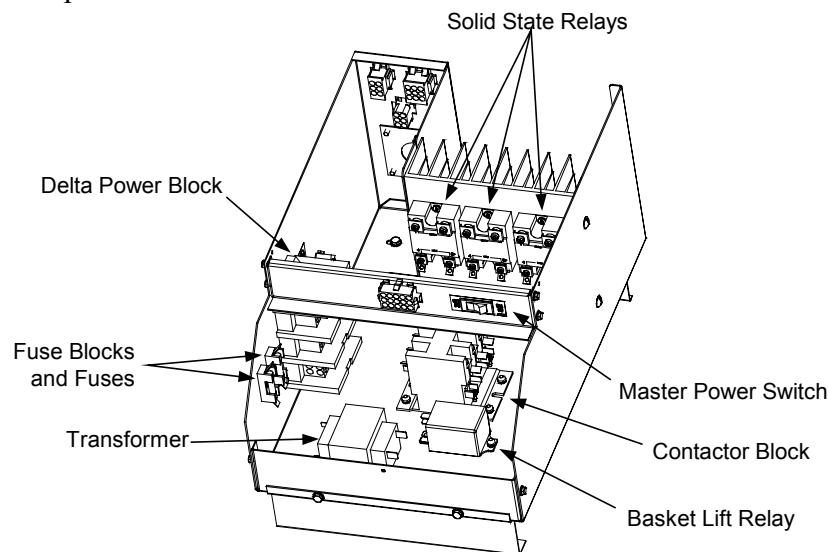

3. On the component to be replaced, make a note of the wiring connection points.
4. Disconnect the wires and remove the failed component. Install the replacement component and reconnect the wiring in accordance with the notes made in Step 3 or with the wiring diagram on the door of the unit.

5. Replace the component box covers, being sure to reconnect the ground wire. Reconnect the cooker to the electrical power supply.

6.3.3 Replacing a Heating Element

1. Drain the cookpot and disconnect the cooker from the electrical power supply. Disconnect the unit from the water supply at the rear of the cooker. Remove the basket lift arms from the unit.
2. Reposition the cooker to allow clear access to the rear of the unit. Remove the upper and lower basket lift panels.

3. Unplug the element connector from the rear of the component box. Depress the locking tabs on each side of the connector and extend the connector to release the element leads (see photo at right). Pull each of the leads out of the connector, being careful not to damage the connector in the process.

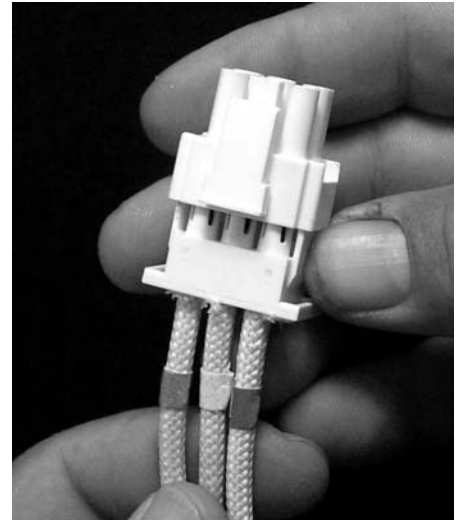

4. If the bundle of element leads is enclosed in a fiberglass insulating sheath, cut the wire ties securing the sheath in place, and remove and discard it; it is no longer required. If replacing the left element (as viewed from the front of the cooker), cut the metal wire ties that secure the high-limit thermostat to the element, being careful not to bend the thermostat in the process.

5. Remove the brass nuts that secure the element in the cookpot and lift the failed element from the cookpot. Recover the Teflon washers from the failed element for use on the replacement.

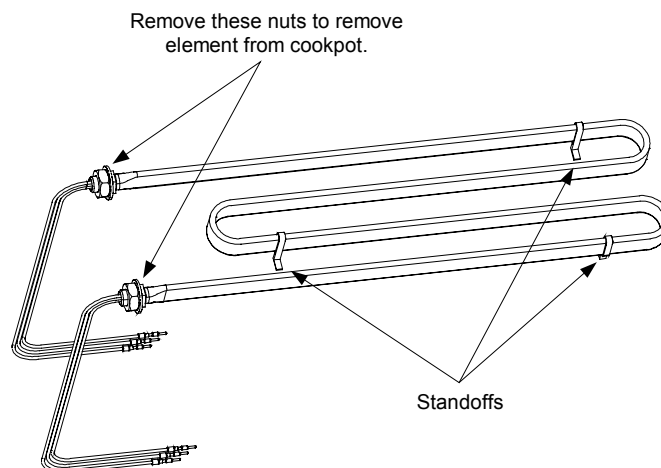

6. Position the replacement element in the cookpot with the standoffs on the bottom of the cookpot. Thread the element leads through the Teflon washers recovered from the failed element. Secure the element in place with the nuts removed in Step 5.
7. If the left element (as viewed from the front of the cooker) was replaced, secure the high-limit thermostat against the inside of the leg of the element with two metal wire ties.

- Insert the pins on the element leads into the element connector in accordance with the illustration below. The insulation on the lead will be flush with the face of the plug when properly positioned. When all leads are positioned correctly, close the connector and verify that the tabs are locked in place. Each element lead is marked with a number that corresponds to the hole in the connector into which it should be inserted. The right element (as viewed from the rear of the unit) uses the 6-pin connector; the left element uses holes 1 through 6 of the 9-pin connector.

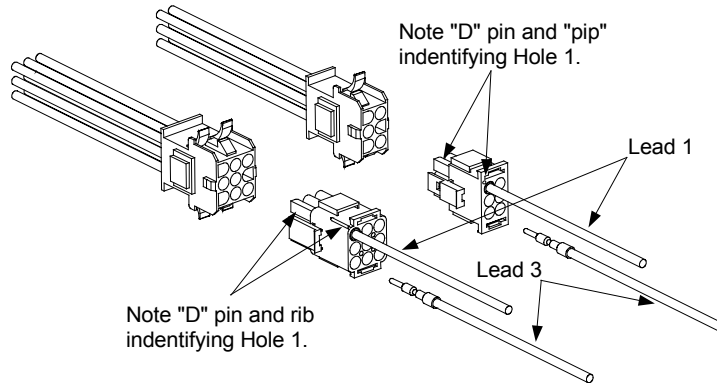

- Bundle all six element leads together and secure with plastic wire ties close to the element and connector, and in the middle.
- Reverse Steps 1 through 3 to complete the procedure.

6.3.4 Replacing the High-Limit Thermostat

- Drain the cookpot and disconnect the cooker from the electrical power supply. Disconnect the unit from the water supply at the rear of the cooker. Remove the basket lift arms from the unit and cut the metal wire ties securing the thermostat tube to the element.
- Reposition the cooker to allow clear access to the rear of the unit. Remove the upper and lower basket lift panels.
- At the rear of the cookpot, loosen the small compression nut, and then unscrew the large fitting from the cookpot. Pull the thermostat tube out through the rear of the cookpot.

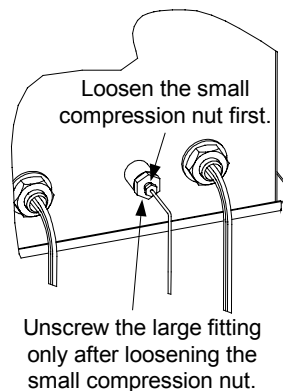

- Detach the high-limit thermostat leads (5C and 8C) from the thermostat. Remove the two screws securing the thermostat to the mounting bracket and remove the thermostat assembly from the cabinet. (**NOTE:** It is not necessary to remove the bracket.)

- Loosen the small compression nut in the large fitting on the replacement thermostat so that the large fitting will move freely on the capillary tube (the thin, flexible tube). Carefully insert the replacement thermostat into the cookpot, being careful not to bend the thermostat tube. Position the tube along the inside of the left leg of the element (as viewed from the front of the cooker) and secure it in place with two metal wire ties. Apply thread sealer to the large fitting and screw the fitting securely into the cookpot. When the large fitting is tight, pull gently on the capillary tube to remove any slack, then screw the small compression nut into the large fitting and tighten.
- Coil the capillary tube as necessary to achieve a neat installation and attach the terminal block to the mounting bracket using the screws removed in Step 4. Connect thermostat lead 5C (black) to the normally closed (NC) terminal and 8C (white) to the common (C) terminal.

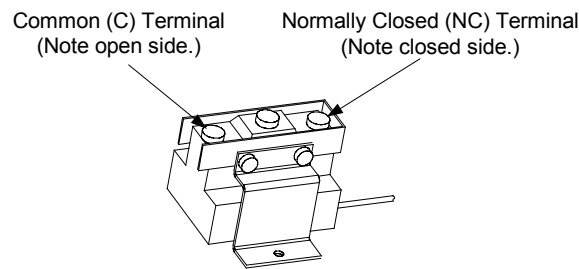

- Reverse Steps 1 and 2 to complete the procedure.

6.3.5 Replacing a Water-Level Sensor

Drain the cookpot and disconnect the cooker from the electrical power supply. Disconnect the sensor lead from the sensor, remove the nuts securing the sensor in place, and remove the sensor. Install the replacement sensor as illustrated below and reconnect the lead.

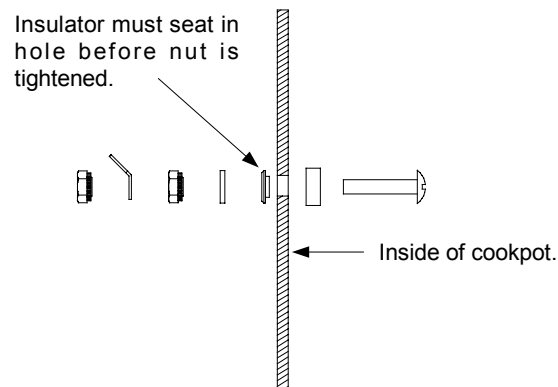

6.3.6 Replacing the Temperature Probe

- Drain the cookpot and disconnect the cooker from the electrical power supply.
- Remove the three screws along the upper edge of the control panel and open the panel by allowing it to swing downward.
- Disconnect the 15-pin connector from the rear of the computer and, using a pin pusher (such as Frymaster P/N 806-4855), push out the temperature probe (red and white) leads from positions 13 and 14 on the connector.

4. Remove the temperature probe by unscrewing it from the front of the cookpot.
5. Apply thread sealer to the replacement probe and screw it securely into the cookpot.
6. Insert the red probe lead into position 13 of the 15-pin connector and the white lead into position 14. Pull gently on each lead to ensure it is firmly seated.

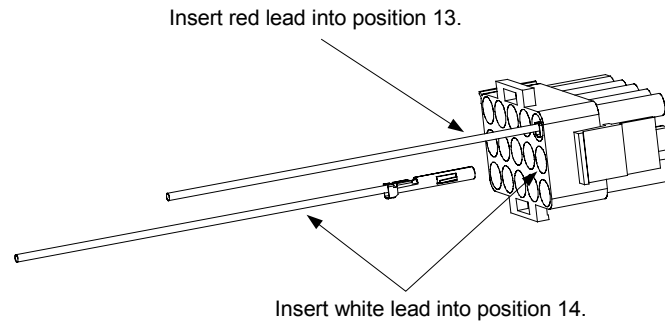

7. Reattach the 15-pin connector to the rear of the computer, close the control panel, and replace the three screws removed in Step 2.

6.3.7 Replacing the Pressure Regulator or Solenoid Valve

1. Drain the cookpot and disconnect the cooker from the electrical power supply. Turn off or disconnect the water supply to the cooker.
2. Loosen the compression fittings on the water lines running to and from the regulator and remove the regulator from the unit. (**NOTE:** If the cooker is equipped with the optional Autofill feature, the solenoid valve is installed between the regulator and the cookpot. If that is the case, disconnect the solenoid leads and remove both the regulator and solenoid valve from the unit.)

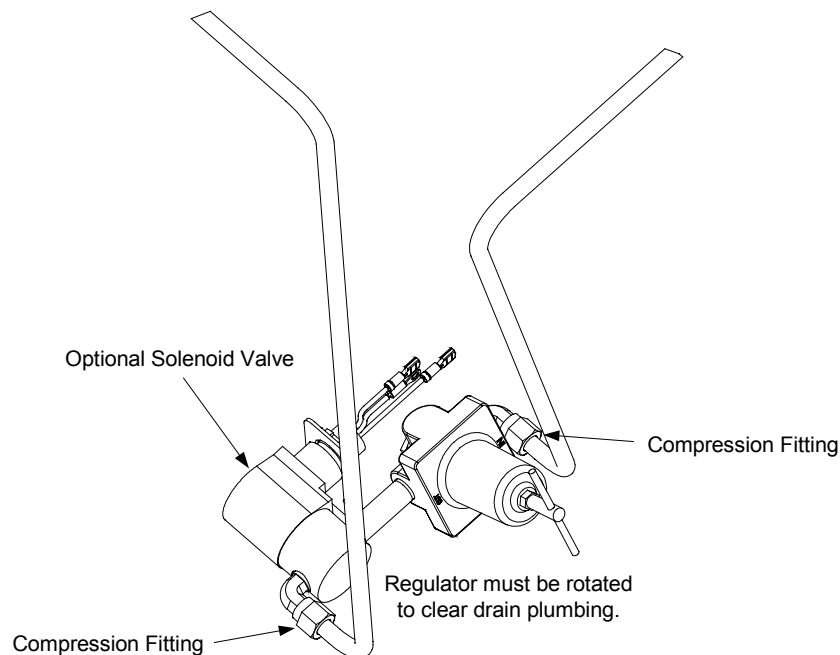

3. If replacing the regulator, adjust the replacement regulator output pressure to not more than 40 PSI (28.15 kg/cm²) before installation in the cooker.
4. Recover the fittings from the failed component (regulator or solenoid valve) and install them on the replacement, using thread sealer on all connections.
5. Reverse Steps 1 and 2 to complete the procedure, being sure to apply thread sealer to all connections. **NOTE:** The regulator must be rotated approximately 45 degrees to clear the drain plumbing (see illustration at Step 2).

6.3.8 Replacing the Water Faucet

1. Drain the cookpot and disconnect the cooker from the electrical power supply.
2. Turn off the water supply to the cooker and disconnect the incoming water lines where they attach to the stubs at the rear of the cooker.
3. Remove the two screws securing the access panel in place and remove the panel.
4. Disconnect the water supply line at the compression fitting where it attaches to the water inlet manifold. Remove the screws from the faucet mounting plate and lift the faucet assembly from the unit.

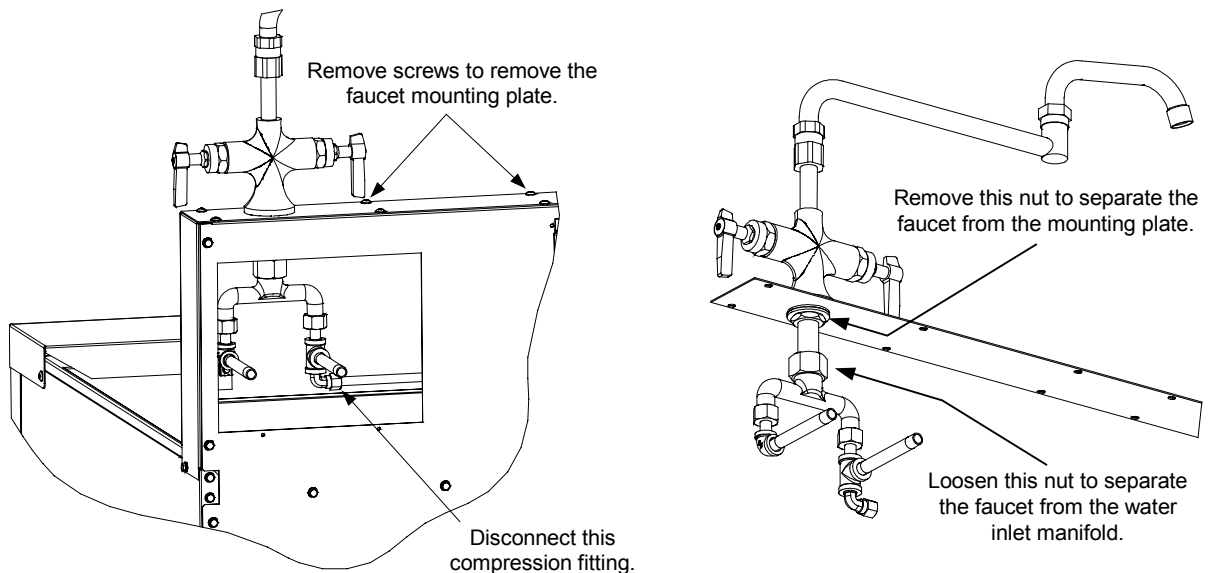

5. Separate the faucet from the water inlet manifold and mounting plate as shown in the illustration at Step 4.
6. Reverse Steps 1-5 to complete the procedure.

6.3.9 Replacing a Basket Lift Motor or Microswitch

1. Disconnect the cooker from the electrical power supply.

2. If rigid water connections have been used, disconnect the cooker from the incoming water supply.
3. Remove the basket lift arms from the lifter rods and then reposition the cooker to gain access to the rear. Remove the upper and lower basket lift rear panels.
4. Unplug the basket lift wiring harness from the lower 6-pin connector on the component box. (To do this, you must reach around behind the component box from the front of the cooker.)

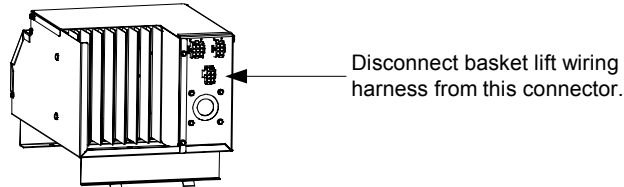

5. Disconnect the basket lift link from the lifter cam (bell crank) assemblies one at a time. When the link is disconnected from a cam, slip the corresponding lifter rod down and out of the assembly (see illustration below).

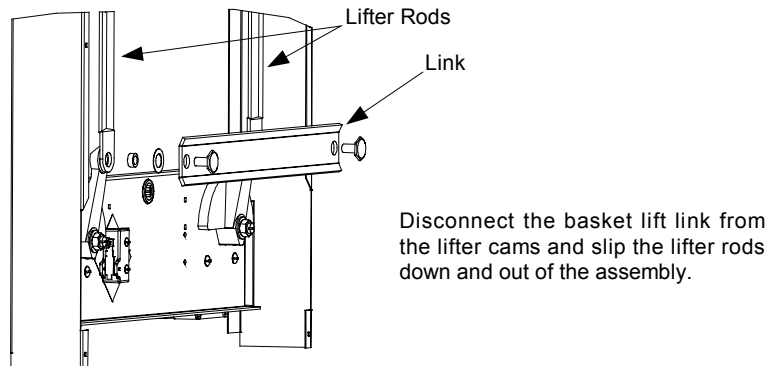

6. Remove the four bolts securing the motor mount to the frame, then remove the motor and mount assembly from the unit. **NOTE:** It is possible to replace a motor or the microswitch without removing the motor and mount assembly, but it is much more difficult.
7. Dismount the motor or microswitch as shown below and install the replacement.

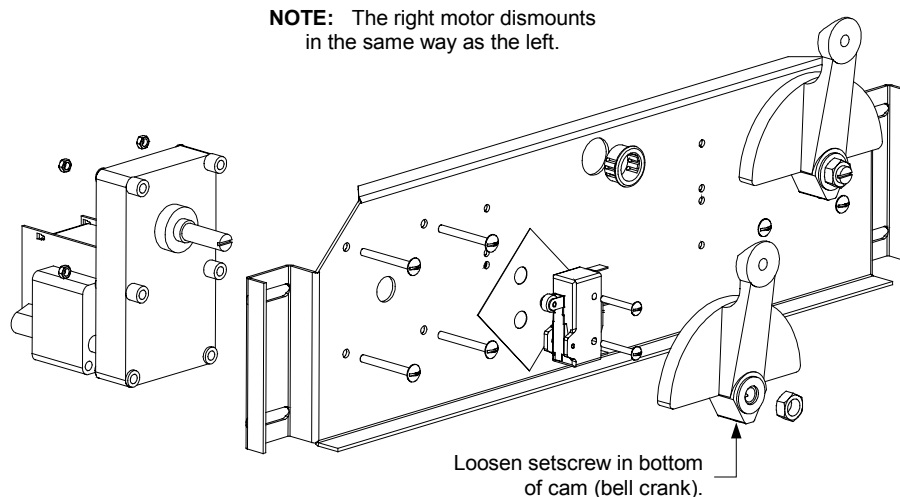

8. Reverse Steps 1-7 to complete the procedure.

6.3.10 Replacing the Cookpot or Rinse Tank

1. Remove the faucet assembly from the cooker in accordance with Steps 1-4 of Section 6.3.8.
2. Remove the screws that secure each of the rear corners of the backsplash assembly (see illustration at right). **NOTE:** To access the screw in the lower right corner (as viewed from the rear) remove the upper basket lift panel.
3. Remove the screws along the top edge of the control panel and open the panel by swinging it downward. Disconnect the 15-pin connector from the rear of the computer, and then lift the control panel out of the control panel frame.
4. Remove the screws that secure the backsplash sides to the cabinet sides then remove the four screws that secure the topcap to the cabinet. Remove the nut and washer securing the basket support rod to the topcap by reaching up through the control panel frame. Conversely, the backsplash and topcap, with the basket support rod still attached, can be lifted up and off the cooker as one unit.
5. Remove the screws attaching the standoff brackets to the cookpot or rinse tank.
6. If removing the cookpot, unplug the element wiring harnesses from the rear of the contactor box. Disconnect the high-limit thermostat leads and the water-level sensor leads. Using a pin-pusher (such as Frymaster P/N 806-4855), disconnect the temperature probe leads from the 15-pin connector.
7. Disconnect the union joining the cookpot and rinse tank drain piping together.
8. With an assistant, lift the cookpot or rinse tank straight up and out of the cabinet.

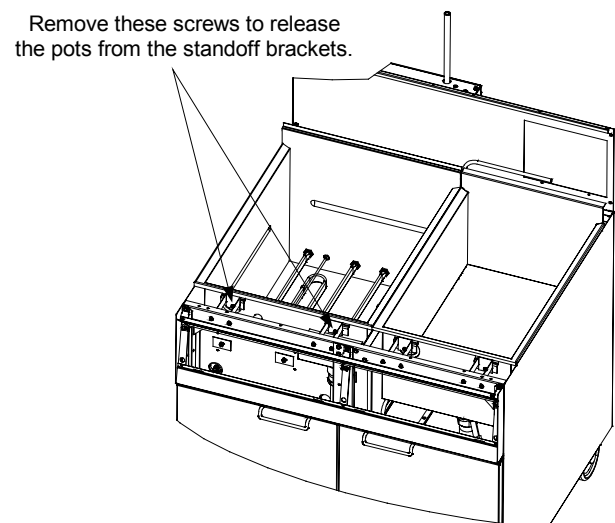
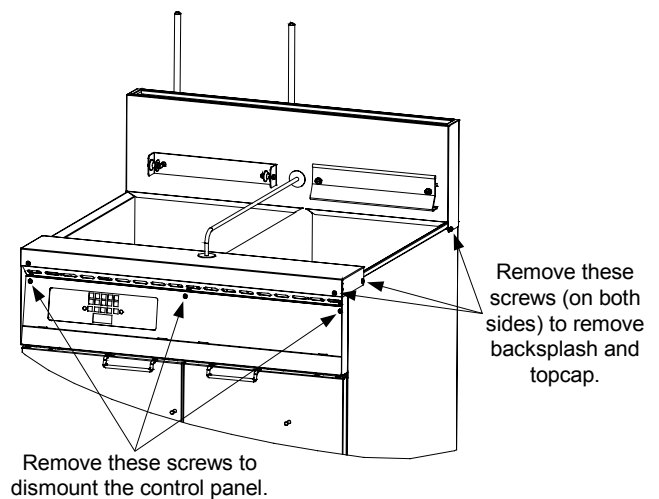
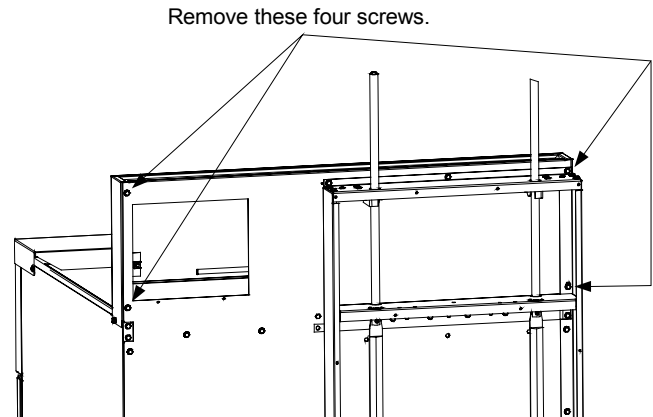

9. Invert the cookpot or rinse tank on a suitable work surface and remove the salvageable components (e.g., elements, thermostats, drain plumbing, etc.). Install the recovered components on the replacement cookpot or rinse tank, using thread sealer on all connections.
10. Reverse Steps 1 through 8 to complete the procedure.

6.4 Troubleshooting

NOTE: 24VAC power to the electronic components of this system is controlled by the master ON/OFF switch located on the front of the contactor box. If this switch is in the OFF position, none of the system components will function.

DANGER

The master ON/OFF switch does not disconnect this equipment from the electrical power source! Line voltage is supplied to the transformer and to the basket lift motors as long as the unit is plugged in.

Problems with this equipment may be grouped into five broad categories:

1. Failure or malfunction of a 24VAC Power-Supply System component.
2. Failure or malfunction of the Computer.
3. Failure or malfunction of an Autofill/AutoSkim System component.
4. Failure or malfunction of a Water Heating System component.
5. Failure or malfunction of a Basket Lift System component.

Sections 6.4.1 through 6.4.5 briefly explain the functioning of each of the systems mentioned above. Section 6.4.6 contains troubleshooting guides that provide systematic procedures to isolate and identify the specific source of a problem. A wiring diagram is located at the end of the chapter.

6.4.1 How the Power-Supply System Works

Line voltage is supplied to the system via a power cord that is plugged or hard-wired into the store's electrical service. The power cord is attached to a three-lug delta-power terminal block. One set of wires delivers line voltage from the load side of the block to Terminal 1 of each of the solid-state relays. A second set of wires delivers line voltage through a pair of 5-Amp fuses to the 24VAC transformer and to the basket lift relay. Line voltage for one side of the basket lift motor circuit is tapped from a "piggy-back" terminal on the line side of the transformer. Line voltage for the other side of the circuit is supplied via the basket lift relay. 24VAC is supplied to the equipment by placing the master ON/OFF switch in the ON position, which grounds the transformer.

6.4.2 How the Computer Works

The SMS III computer provides the interface between the operator and the system components. The computer is powered by 24VAC supplied through Pins 1 (hot) and 2 (ground) of the 15-pin wiring harness. Internal circuitry senses the water level, water temperature, and element temperature. Depending upon the conditions sensed, the computer energizes or de-energizes the solenoid valve to control water level and the heating elements to control water temperature. The computer also controls the lowering and raising of the basket lift, and activates an audible alarm to signal the operator that a cooking cycle has completed. A rectifier in the computer converts 24VAC to the

24VDC required by the basket lift relay and the solid-state heating relays. The computer signals for heat via Pin 4, grounds the solenoid valve via Pin 6, and senses water level via Pins 7 (low) and 9 (full). The temperature probe connects to Pins 13 and 14. The basket lift relay connects to Pins 10 and 12. The sound device connects to Pin 11.

6.4.3 How the Autofill/AutoSkim System Works

The heart of the automatic filling (Autofill) system is a normally closed solenoid valve that opens when 24VAC is applied.

The ground for the solenoid is supplied (via Pin 6 of the computer wiring harness) so long as the upper water-level sensor is not in contact with the water in the cookpot. When the water in the cookpot reaches the upper water-level sensor, the sensor is grounded. This causes the computer to break the solenoid ground, closing the valve. Starch or lime build-up on the upper water-level sensor may keep a ground from forming, therefore always make sure the sensor is clean and its lead (Pin 9 of the computer wiring harness) is firmly connected. Also, in order for the ground to form, there must be some mineral content in the water (pure water is non-conductive). Consequently, the units will not operate with distilled water. If distilled, highly filtered, or purified water is used, add 1/8-cup of baking soda to the water each time the cookpot is emptied and refilled.

When the AutoSkim feature is activated by pressing the skim switch on the computer, a logic circuit in the computer automatically opens the solenoid valve for three seconds every minute until the switch is again pressed. If the Autofill feature is working properly, failure of the AutoSkim feature will be due to a malfunctioning computer and not the solenoid valve. (Proper operation of the Autofill feature can be determined by draining water from the cookpot until the water level is below the upper water-level sensor. If the solenoid valve opens and then closes when the water in the cookpot again reaches the upper water-level sensor, the Autofill feature is working properly.)

6.4.4 How the Water Heating System Works

To prevent energizing the heating elements when there is no water in the cookpot, these units are equipped with a **low-water-level sensor**. This sensor must be grounded by contact with water in the cookpot before the control circuitry will apply power to the elements. Starch or lime build-up on the low-water-level sensor may keep the ground from forming, therefore always make sure the sensor is clean and its lead (Pin 7 of the computer wiring harness) is firmly connected. In order for the ground to form, there must be some mineral content in the water (pure water is non-conductive). Consequently, the units will not operate with distilled water. If distilled, highly filtered, or purified water is used, add 1/8-cup of baking soda to the water each time the cookpot is emptied and refilled.

In addition to the low-water-level sensor discussed above, the water heating system has six more parts: the high-limit thermostat, the temperature probe, the contactor, the element, a group of three solid-state relays, and the computer.

The **high-limit thermostat** functions as a normally closed switch. If the water in the cookpot falls below the low-water-level sensor but the sensor remains grounded (for whatever reason), the high-limit switch will open when the element temperature reaches 400°F ±15 (204°C ± 9). This cuts power to the contactor coil and thus to the element.

The **temperature probe** is used only when the unit is in the simmer mode. When the operator selects the simmer mode, logic circuits in the computer monitor the temperature of the water and cycle power to the element on and off as required to maintain the temperature at the setpoint programmed into the computer.

The **contactor** is the terminal block to which the element leads are connected and where actual contact is made between the leads and the line voltage. Built into the contactor is a 24VAC coil that energizes when the master ON/OFF switch is placed in the ON position. When it energizes, contact is made between the incoming line voltage and the element leads, and line voltage is supplied to one side of the element circuit. The **solid-state relays** control the supply of line voltage to the other side of the element circuit. The relays are closed when the computer is calling for heat and open when it is not.

The **element** is a resistive heating device. That is, when voltage is applied to the element, the element gets very hot due to its resistance to current flow through it. The heat generated is transferred directly to the water in which the element is immersed.

The **computer** is the interface between the operator and the other components of the equipment. In the water heating system, its function is to control the application of line voltage to the heating element via the solid-state relays.

When in the *Simmer Mode*, the signal from the computer is continuous, the solid-state relays are continuously closed, and line voltage is applied to the elements until the simmer setpoint (195°F/90.6°C) is reached.

When in the *Boil Mode*, the signal from the computer is continuous for approximately the first 40 seconds, then changes to a series of on-off pulses of equal duration. The solid-state relays close and open in response to the signal from the computer, and line voltage is applied to the elements accordingly. (The pulsing of the line voltage to the elements prevents the water in the cookpot from reaching a vigorous, roiling boil. This, in turn, minimizes the formation of starch foam. An added benefit of the pulsing is reduced electrical power consumption.)

6.4.5 How the Basket Lift System Works

When the Start switch is pressed to start the cooking cycle, logic circuits in the computer activate the basket lift motors, lowering the basket into the cookpot. As the motors drive the basket lift arms down, a cam attached to the left motor eventually loses contact with a roller-activated microswitch and power to the motors is cut. When the computer times out, logic circuits reverse the switch positions so that the motor circuit is again completed and the motors are restarted, raising the basket from the cookpot. At the fully raised position, the cam again makes contact with the microswitch, cutting power to the motors and stopping the lift in the up position.

6.4.6 Technician Troubleshooting Guides

TROUBLESHOOTING THE 24VAC POWER SUPPLY SYSTEM

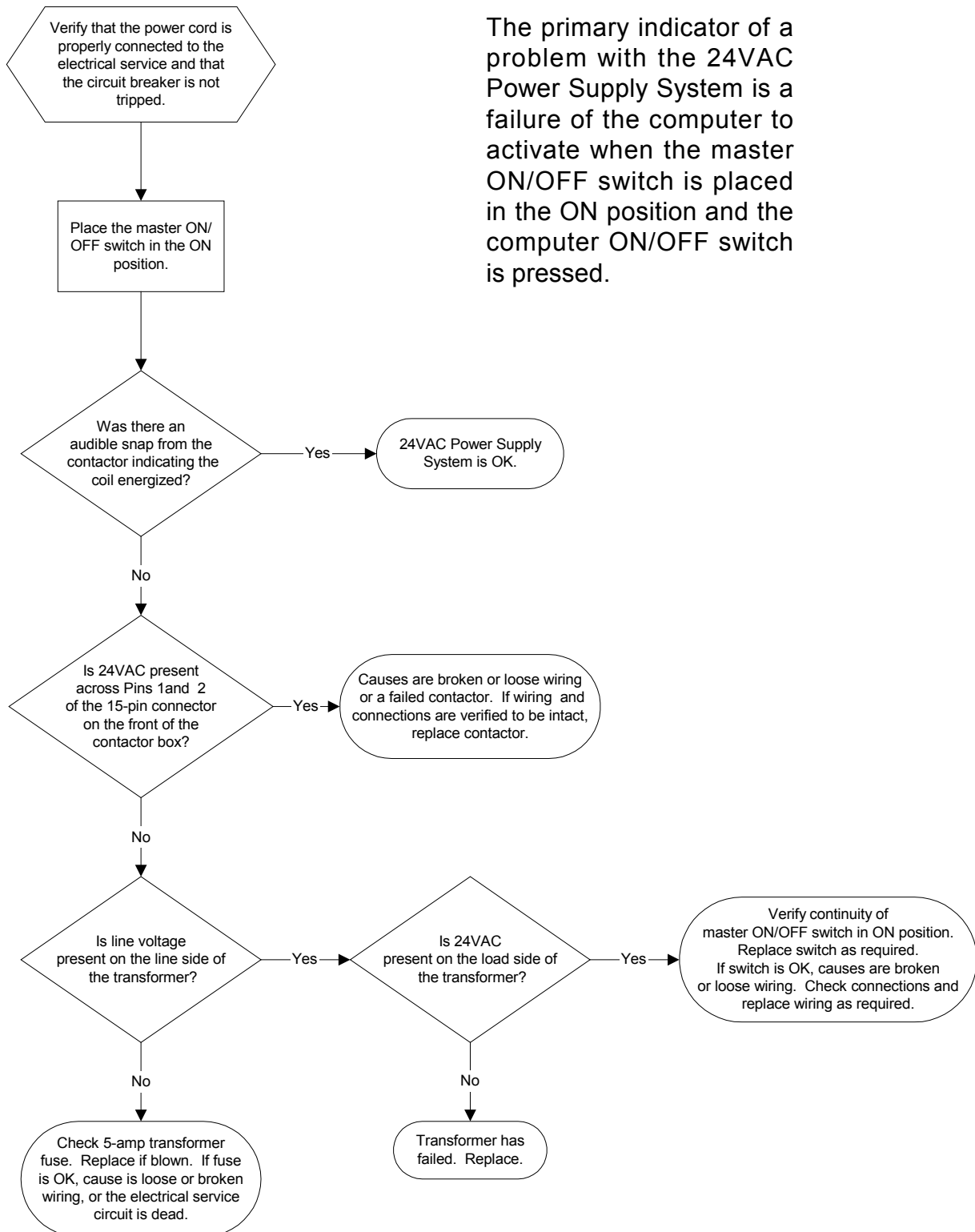

TROUBLESHOOTING THE 24VAC POWER SUPPLY TO THE COMPUTER

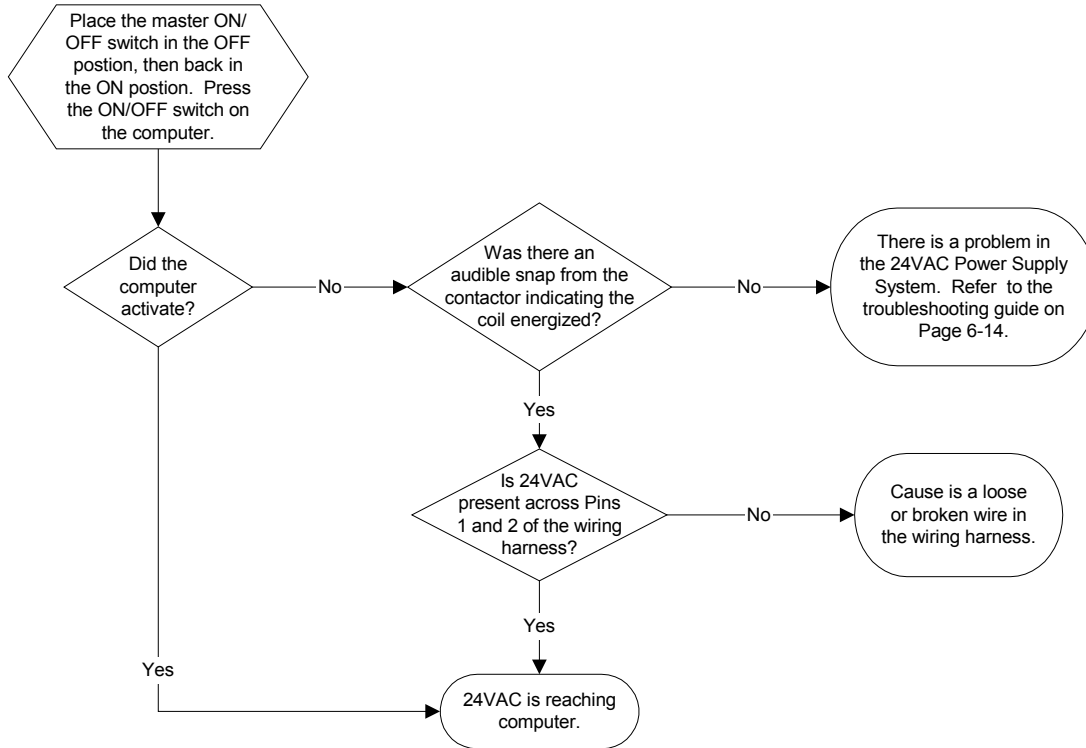

TROUBLESHOOTING THE AUTOFILL SYSTEM

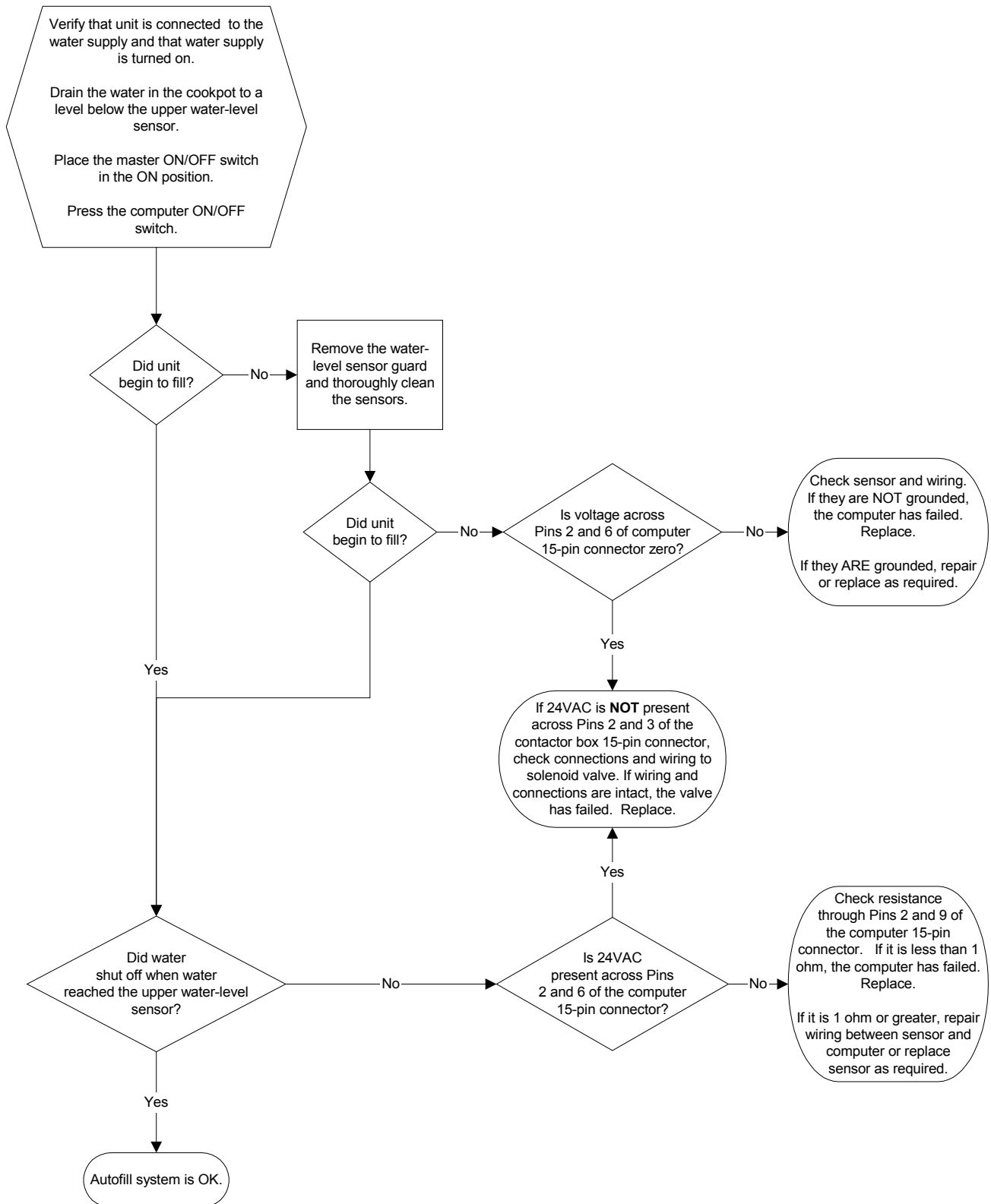

TROUBLESHOOTING THE WATER HEATING SYSTEM

Each of the following checks is to be performed with the unit connected to the electrical power supply, with the computer ON and calling for heat, and with at least enough water in the cookpot to cover the lower water-level sensor.

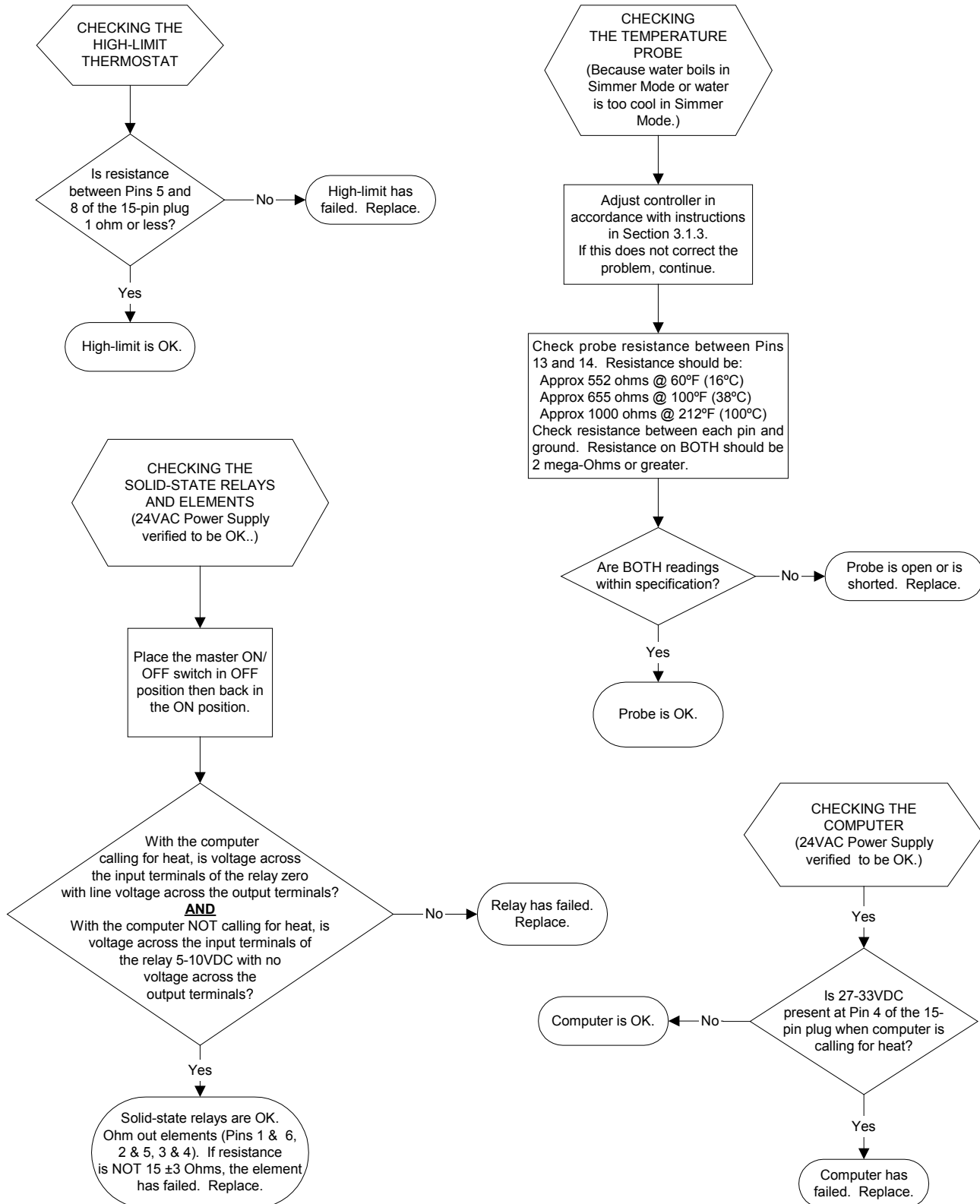

TROUBLESHOOTING THE BASKET LIFT SYSTEM

If the basket lift motors are activating, but the basket lift fails to raise or lower, or if its movement is erratic, the probable cause is jamming or binding of the basket lift rods. Apply a light-weight white grease (such as Lubriplate™) to the rods. If this does not correct the problem, check for bent or otherwise damaged rods and links, and for loose bellcranks.

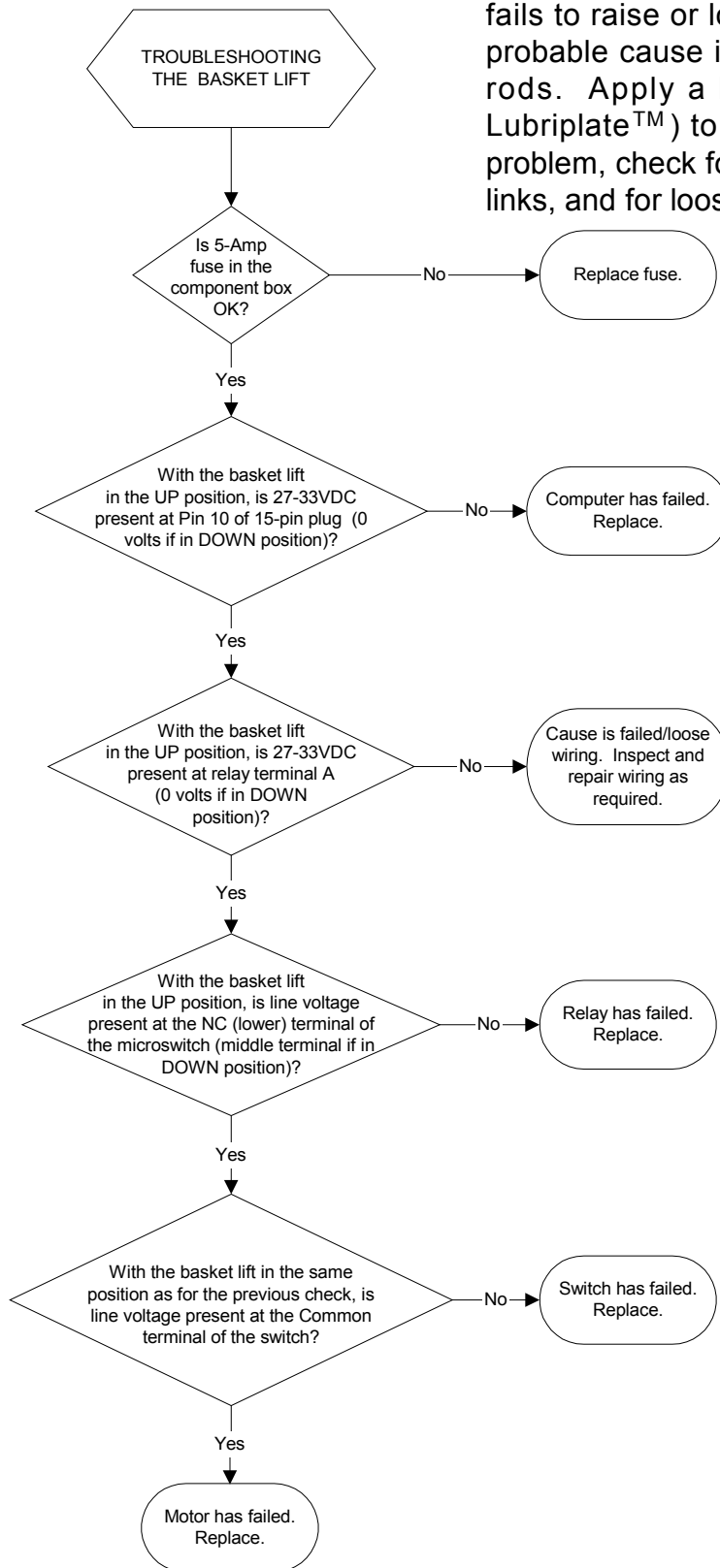

**THIS PAGE INTENTIONALLY
LEFT BLANK.**

6.5 Parts List

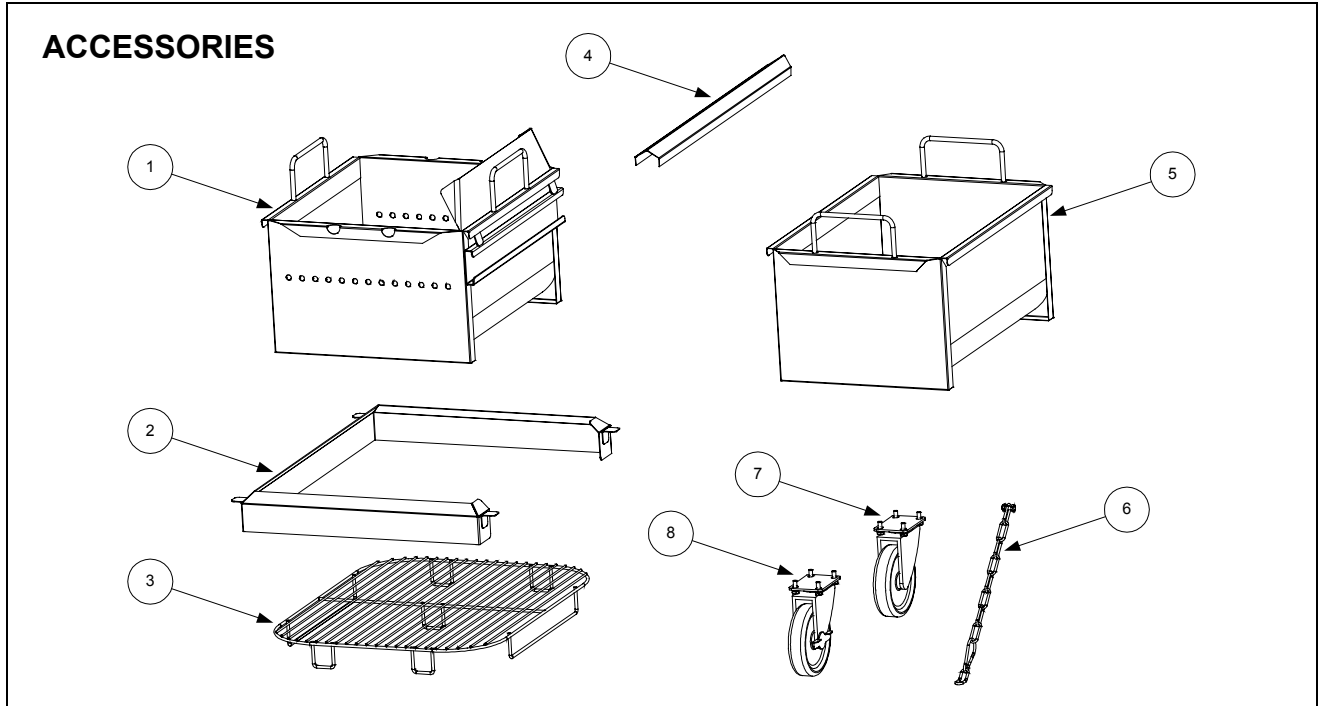

ITEM	PART #	COMPONENT
1	823-2939	Cooking Basket
2	823-2936	Starch Diverter
3	803-0268	Basket Support Rack
*	210-5068	Pan Insert
4	910-7540	Cookpot/Rinse Tank Top Connecting Strip
5	823-2938	Rinse Basket
6	826-0900	Chain Restraint Kit
7	826-1117	Caster without Brake, 5-Inch (includes mounting hardware)
8	826-1118	Caster with Brake, 5-Inch (includes mounting hardware)

BASKET LIFT COMPONENTS

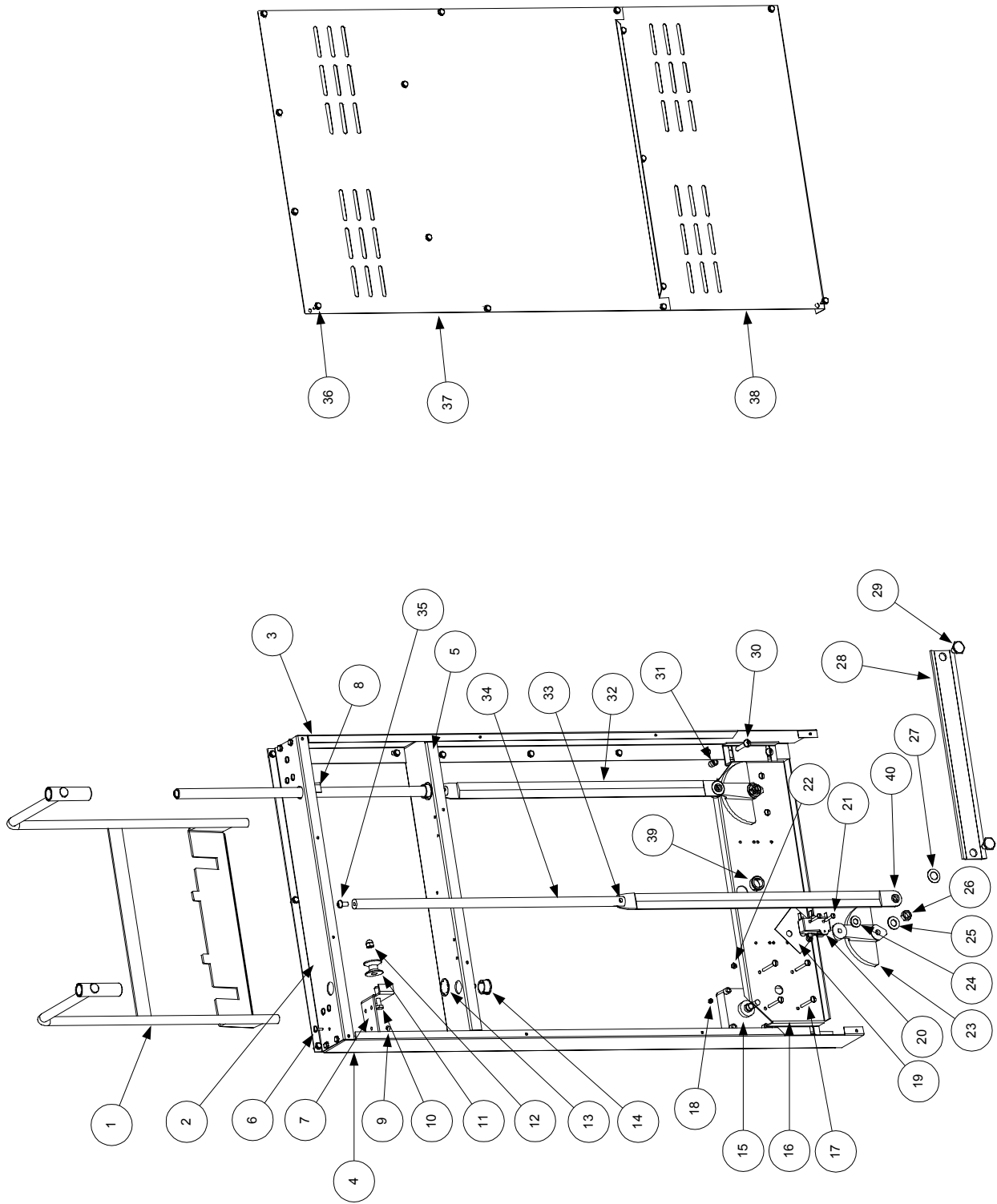

ITEM	PART #	COMPONENT
1	823-2007	Arms, Basket Lift
2	910-7420	Top, Basket Lift Enclosure
3	911-7417	Side, Basket Lift Enclosure Right
4	912-7417	Side, Basket Lift Enclosure Left
5	900-7421	Support, Basket Lift Rod Bushing
6	826-1363	Screw, 8-32 x 1/2-inch Slotted Truss Head (Pkg of 25)
7	902-1927	Bracket, Left Basket Lift Roller
8	901-1927	Bracket, Right Basket Lift Roller
9	809-0247	Nut, 8-32 Hex Keps
10	809-0508	Bolt, 1/4 -20 x 1 1/4-inch Hex Head SS
11	810-0194	Roller, Basket Lift
12	809-0047	Nut, 1/4-20 SS Hex Cap
13	809-0082	Ring, 3/4-inch Truarc
14	810-0045	Bushing, Basket Lift Rod
15	807-0108	Motor, 240VAC Basket Lift
16	900-7416	Mount, Basket Lift Motor
17	809-0113	Screw, 8-32 x 1 1/2-inch Slotted Truss Head
18	809-0050	Nut, 8-32 Hex
19	812-0138	Insulation, Motor Mount (Fishpaper)
20	807-0240	Microswitch
21	809-0097	Screw, 6-32 x 1-inch Slotted Truss Head
22	826-1358	Nut, 6-32 Hex (Pkg of 25)
23	810-0052	Cam (Bellcrank), Basket Lift
24	809-0194	Washer, 5/16-inch SAE Flat
25	809-0196	Washer, 3/8-inch SAE Flat
26	809-0063	Nut, Jam 3/8-16 Hex
27	826-1381	Washer, 1/2-inch ID x 7/8-inch OD Nylatron Flat (Pkg of 10)
28	910-4525	Bar (Link), Basket Lift Synchronizing
29	809-0155	Screw, 5/16-18 x 5/8-inch Leveling
30	826-1370	Screw, 1/4-20 x 1 1/4-inch Slotted Round Head (Pkg of 10)
31	809-0076	Nut, 1/4-20 x 3/4-inch Expansion
32	920-6076	Link, Basket Lift
33	810-0170	Pin, 1/4-inch x 5/8-inch Spring Dowel
34	810-0192	Rod, 19 5/8-inch Basket Lift
35	809-0127	Screw, 1/4-20 x 1/2-inch Slotted Round Head
36	809-0719	Screw, #10 x 1/2-inch 410SS
37	900-7418	Panel, Upper Basket Lift Rear
38	900-7419	Panel, Lower Basket Lift Rear
39	807-0124	Bushing, Heyco
40	810-0220	Spacer, Tubular, .493-inch OD

CABINETRY

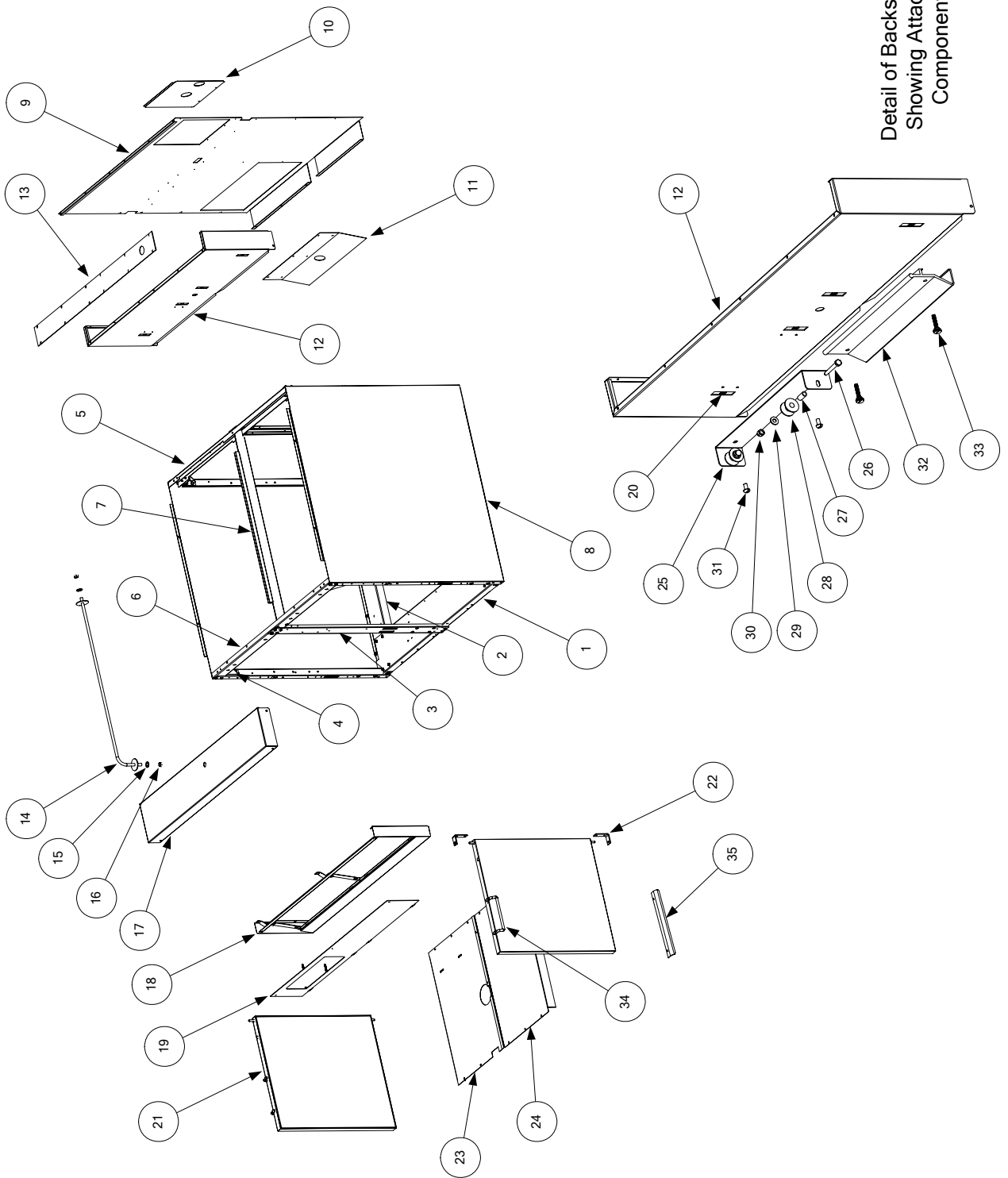

ITEM	PART #	COMPONENT
1	210-0815	Channel, Front or Rear Base
*	806-5209	Leg Pad Assembly (on bottom of Item 1, for mounting casters)
2	210-0816	Channel, Side Base
3	900-7198	Post, Door
4	900-1552	Gusset (Corner Brace)
5	900-7389	Brace, Top Rear
6	900-7390	Brace, Top Front
7	900-7391	Divider, Cabinet
8		Side, Left or Right Cabinet
	910-7377	Stainless Steel
	900-7377	Cold Rolled Steel (Painted)
9	900-7422	Back, Cabinet
*	826-1374	Screw, #10 x 1/2-inch Hex Washer Head (large cabinet screw) (Pkg of 25)
10	900-1750	Panel, Plumbing Access
*	826-1371	Screw, #8 x 1/2-inch Hex Head (access panel screw)
11	900-4645	Shield, Heat
12	210-0007	Backsplash
13	210-0215	Plate, Faucet Mounting
*	809-0740	Screw, #10 x 1/2-inch Phillips Truss Head (faucet plate and topcap screw)
14	810-1838	Rod, Basket Pivot
15	809-0200	Washer, 1/2-inch Flat
16	809-0063	Nut, 3/8-16 Jam
17	824-0801	Topcap
18	806-5487	Frame, Control Panel
19	823-2946	Panel, Control
20	826-1351	Retainer, 1/4-20 Nut (Nutsert) (Pkg of 10)
21	806-9744	Door Assembly, Left or Right (does not include handle or hinges)
*	809-0266	Screw, #10 x 1/2-inch Phillips Truss Head (door panel and handle screw)
22	810-1508	Hinge, Universal Door
23	210-0817	Shield, Left Moisture
24	210-0818	Shield, Right Moisture
25	910-4831	Bracket, Basket Lift Roller
26	809-0508	Bolt, 1/4-20 x 1 1/4-inch Hex Head
27	810-0374	Spacer, Basket Lift Roller Tubular
28	810-0194	Roller, Basket Lift
29	809-0190	Washer, 1/4-inch SS Flat
30	809-0047	Nut, 1/4-20 Hex Head Cap
31	809-0127	Screw, 1/4-20 x 1/2-inch Slotted Round Head
32	803-0028	Hanger, Basket (for wire-form hanger use 810-2229)
33	809-0171	Thumbscrew, Basket Hanger
34	810-1402	Handle, Wireform Door
35	210-9214	Handle, Eurolook Door

* Not illustrated.

COOKPOT, RINSE TANK, AND DRAIN COMPONENTS

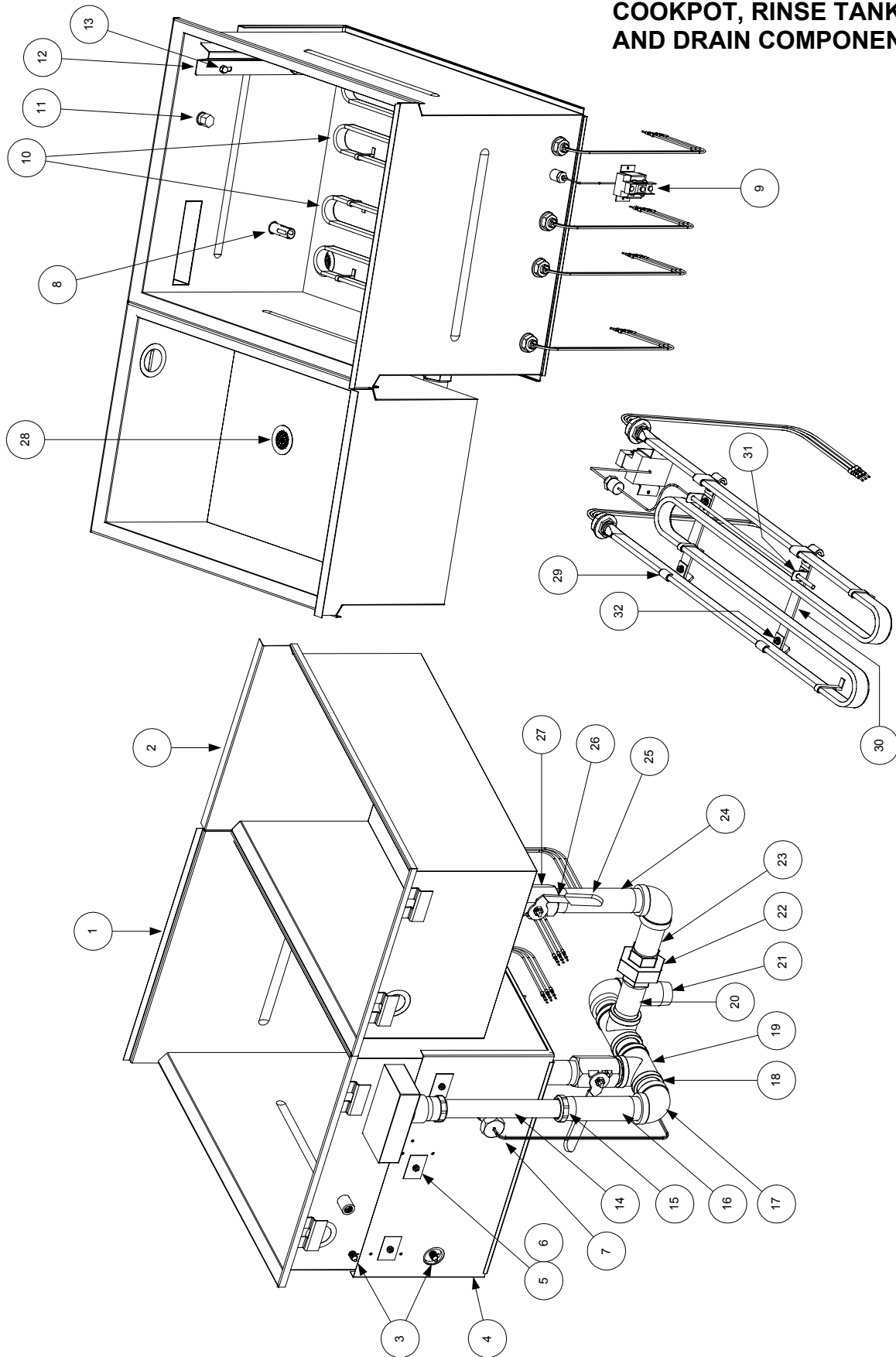

Detail of High-Limit Thermostat Mounting Hardware

ITEM	PART #	COMPONENT
1	823-2937SP	Cookpot Assembly (for 17EMCS (McDonald's), use 823-3827SP)
2	823-1994SP	Rinse Tank Assembly
3	806-7552SP	Water Level Sensor Assembly
4	900-5045	Retainer, Cookpot Front Insulation
*	816-0152	Insulation, Cookpot Front (behind Item 4)
5	900-1762	Retainer, Insulation
6	826-1376	Nut, 10-32 Hex Head Keps (Pkg of 10)
7	807-3333	Probe, Temperature
8	210-0681	Guard, Temperature Probe
9	807-2466	Thermostat, High-Limit
10	807-3814	Element, 208V 8.625kW (for 230V, use 807-3815; for 240V, use 807-3816)
11	810-0976	Nozzle
12	N/A	Guard, Water Level Sensor (part discontinued; no longer used)
13	809-0047	Nut, 1/4-20 Cap (secures Item 12 on units built before February 2001)
14	813-0451	Nipple, 1 1/4-inch NPT x 12-inch Chromed Brass
15	813-0453	Nut, 1 1/4-inch NPT Chromed Stainless Steel Slip
16	813-0148	Nipple, 1 1/4-inch NPT x 6 1/4-inch NPT
17	813-0070	Elbow, 1 1/4-inch NPT 90°
18	813-0400	Nipple, 1 1/4-inch NPT x 2-inch
*	813-0391	Nipple, 1 1/4-inch NPT Close (connects cookpot drain valve and Item 19)
19	813-0394	Tee, 1 1/4-inch NPT
20	813-0146	Nipple, 1 1/4-inch NPT x 4 1/4-inch
21	813-0518	Nipple, 1 1/4-inch NPT x 4-inch
22	813-0395	Union, 1 1/4-inch NPT
23	813-0144	Nipple, 1 1/4-inch NPT x 3 3/4-inch
24	813-0554	Nipple, 1 1/4-inch NPT x 7-inch
25	814-0047	Sleeve, Red Drain Valve Handle
26	910-9527	Handle, Drain Valve
27	810-1825	Valve, 1 1/4-inch NPT Drain
28	823-2022	Strainer
29	910-2042	Clamp, Element
30	910-5214	Support, Element
31	910-2097	Bracket, High-Limit
32	809-0769	Screw, #8 X 3/8-inch S/S Hex Washer Slot Head
*	809-0204	Washer, Teflon (fits between Item 10 and inside face of Cookpot)
*	809-0063	Nut, 3/8-16 Jam (secures Drain Valve Handle to Drain Valve)

* Not illustrated.

ELECTRONICS

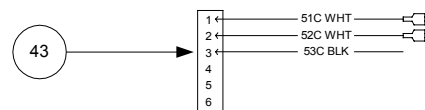
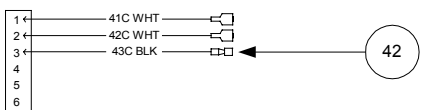
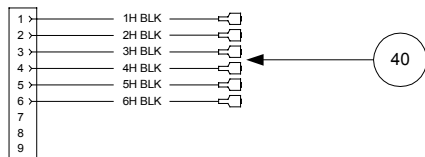
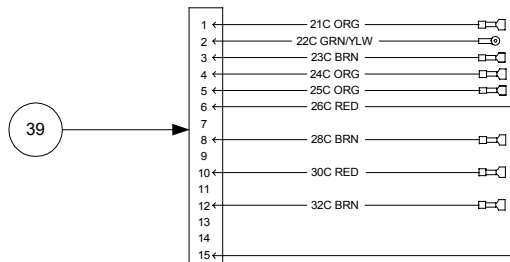
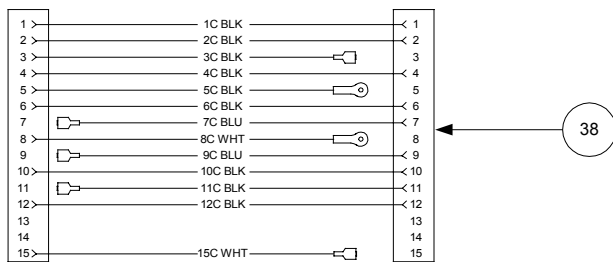
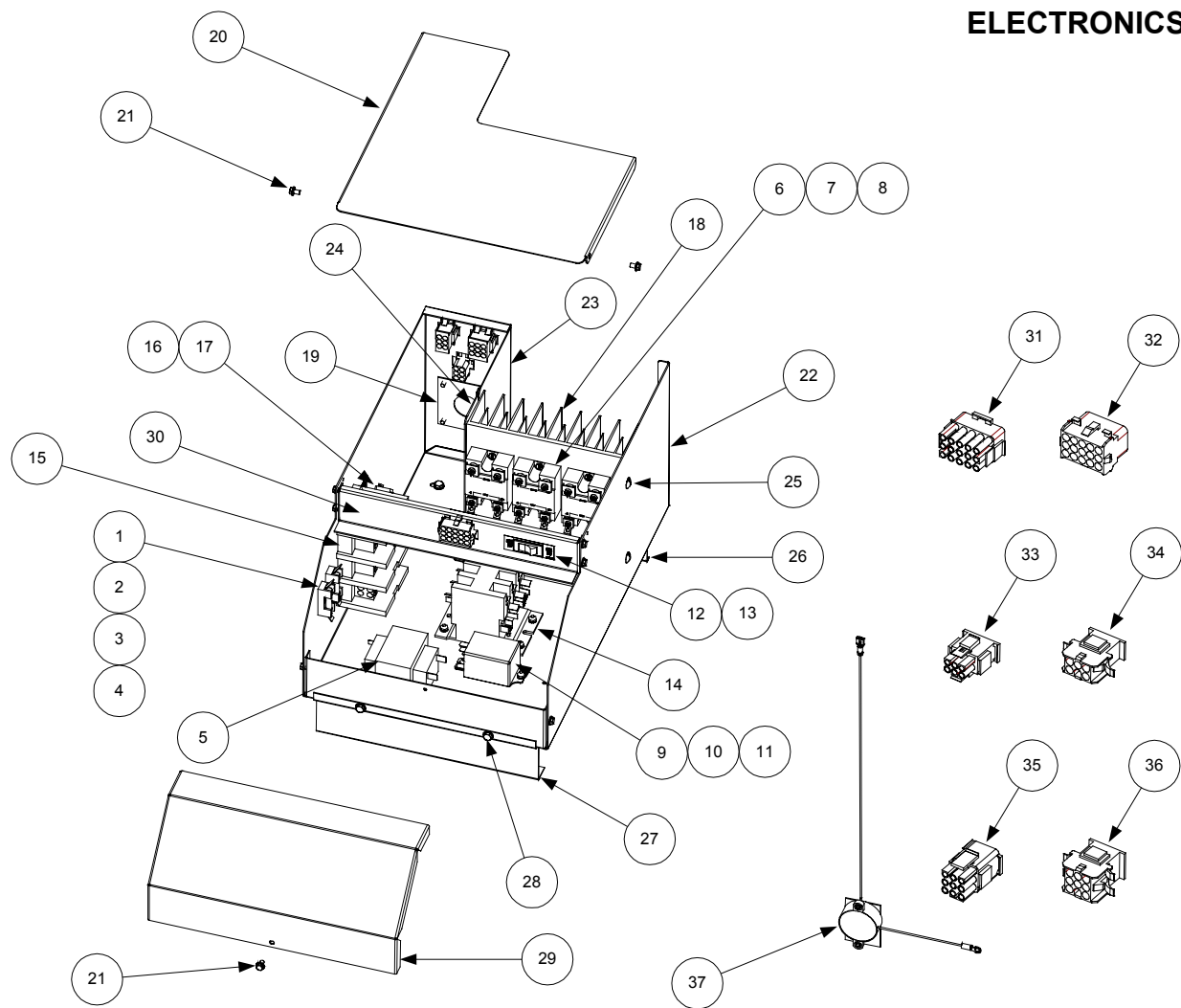

ITEM	PART #	COMPONENT
*	106-0385	Computer, 17ECS
*	824-0856	Starch Shield (mounts to back of control panel to protect computer)
1	807-1555	Fuse, 5 Amp
2	807-1308	Holder, Fuse
3	809-0328	Screw, 4-40 x ¼-inch Slotted Pan Head
4	809-0237	Nut, 4-40 Hex Head Keps
5	807-0680	Transformer, 208-240VAC/24VAC 50/60Hz 43VA
6	807-3996	Relay, 75 Amp 280V SPST-NO Solid State
*	815-0554	Compound, Heatsink (GC Thorsen 10-8109)
7	807-0037	Tab, Faston 6.35 (.250) Series
8	809-0096	Screw, 6-32 x ⅝-inch Binding Slotted Head
9	807-1396	Relay, 24VDC SPDT
10	809-0102	Screw, 8-32 x ⅜-inch Slotted Truss Head
11	809-0247	Nut, 8-32 Hex Head Keps
12	807-2082	Switch, Non-Illuminated Rocker
13	802-1793A	Label, ON/OFF
14	810-1202	Contactor, 3 Pole 600VAC 40 Amp
15	807-2464	Block, Delta Power
16	807-0070	Terminal, Ground Lug
17	802-0742B	Label, Ground
18	807-2749	Heatsink
19	900-2752	Plate, Cordset
20	900-5895	Top, Triac Contactor Box
21	809-0359	Screw, #8 x ¼-inch Slotted Hex Washer Head
22	200-0008	Box, Triac Contactor
23	900-5785	Rear, Triac Contactor Box
24	900-8239	Rear, Split Triac Contactor Box
25	809-0117	Screw, 10-32 x ⅜-inch Slotted Truss Head
26	200-0180	Brace, Contactor Box Rear
27	200-0181	Brace, Contactor Box Front
28	826-1374	Screw, #10 x ½-inch Hex Head
29	900-5445	Cover, Contactor Box Front
30	200-0001	Bracket, Connector
31	807-0804	Connector, 15-pin Male
32	807-0875	Connector, 15-pin Female (Panel Mount)
33	807-2135	Connector, 6-pin High-Amp Male
34	807-2136	Connector, 6-pin High-Amp Female
35	807-2137	Connector, 9-pin High-Amp Male
36	807-2138	Connector, 9-pin High-Amp Female
37	806-3660	Sound Device, High-Output
38	106-0144	Harness, Computer to Contactor Box 15-pin Wiring
39	106-0158	Harness, Contactor Box Internal 15-pin Wiring
40	106-0157	Harness, Element to Contactor 9-pin Wiring
41	106-0156	Harness, Element to Contactor 6-pin Wiring
42	106-0159	Harness, Basket Lift Relay 6-pin Wiring
43	106-0160	Harness, Basket Lift to Contactor Box 6-pin Wiring

* Not illustrated.

WATER SUPPLY SYSTEM COMPONENTS

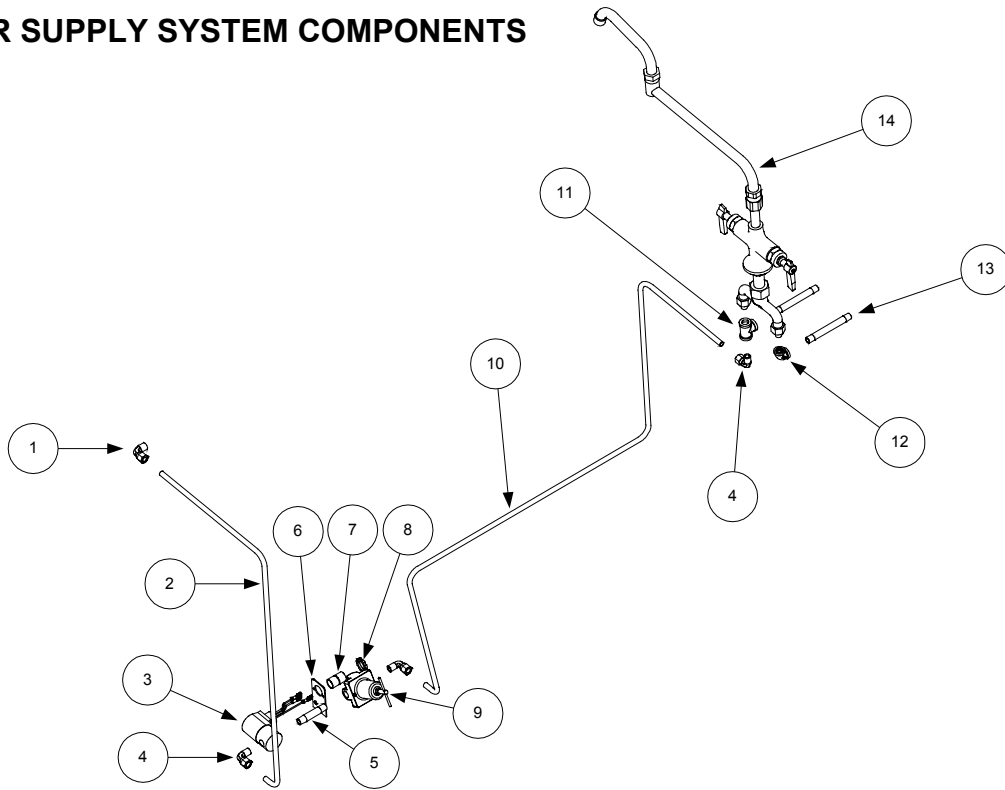

ITEM	PART #	COMPONENT
1	810-0907	Elbow, $\frac{3}{8}$ -inch NPT Compression
2	910-2513	Tubing, Solenoid Valve to Cookpot $\frac{3}{8}$ -inch Stainless Steel
3	806-5565	Valve Assembly, 24VAC 60Hz Solenoid
4	813-0302	Elbow, $\frac{3}{8}$ -inch Tube to $\frac{1}{4}$ -inch NPT 90° Brass Male
5	813-0472	Nipple, $\frac{1}{4}$ -inch NPT x 2.5-inch Brass
6	900-1905	Mount, Solenoid Valve
7	813-0022	Nipple, $\frac{1}{2}$ -inch NPT x Close
8	809-0454	Nut, $\frac{1}{2}$ -inch Conduit
9	810-1208	Valve, Pressure Regulator
10	900-1898	Tube, $\frac{3}{8}$ -inch Water Line
11	813-0449	Tee, $\frac{1}{4}$ -inch NPT Brass
12	813-0448	Elbow, $\frac{1}{4}$ -inch NPT 90° Brass
13	813-0473	Nipple, $\frac{1}{4}$ -inch NPT x 4-inch Brass
14	813-0412	Faucet, Double Jointed Pantry
*	826-1132	Kit, Faucet Repair (contains two valve assemblies)

* Not illustrated.

6.7 Wiring Diagrams (17EMCS)

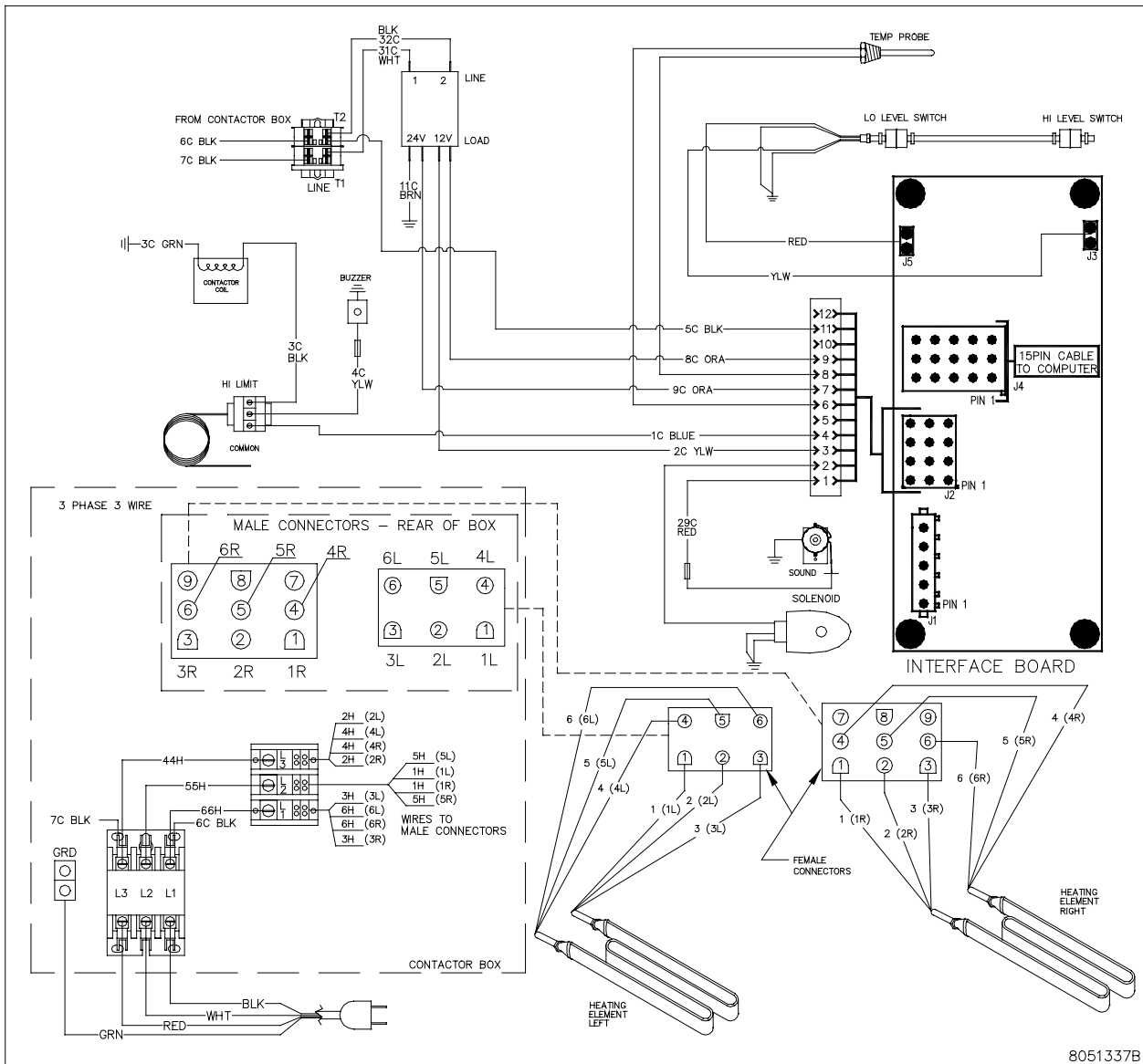

8051337B

THIS PAGE INTENTIONALLY LEFT BLANK.

ELECTRIC COOKER MODELS 17EC, 17ECS, ESW AND EWBS

CHAPTER 7: ESW & EWBS SERVICE PROCEDURES & PARTS

7.1 Functional Description

The ESW series was the predecessor to the EWBS series. Both cookers are very similar in construction and function. The cookers in the ESW series have rocker-switch controls only. These cookers were configured as single units or as batteries of two units. The primary difference between the two configurations is in the piping of the Autofill water supply system and the lack of the basket lift and computer options on ESW units.

Cookers in the EWBS series may be configured with computer controls or with the rocker-switch controls as used on the ESW cookers. E1WBS models consist of a single cooker. E2WBS models consist of two single units battered together.

All models feature a 16.5-gallon (62.5-liter) stainless steel cookpot. The water in the cookpot is heated by a 13-kilowatt heating element. Optional features include a swing-away jointed faucet and automatic filling and skimming features (Autofill and Autoskim).

Units with Manual Controls (rocker-switches and a thermostat)

When the POWER switch is placed in the ON position, the white POWER indicator next to the switch illuminates. If the red TROUBLE indicator illuminates at any time, there is a problem with the high-limit thermostat. The unit will not heat until the problem with the high-limit thermostat has been resolved. Anytime the POWER switch is in the ON position, logic circuits in the interface board check for the presence of water in the cookpot. These circuits look for grounding of the water level sensors caused by their contact with water in the cookpot.

If the interface board senses that the cookpot is not full, (i.e., the upper water level sensor is not in contact with water) it signals the normally closed solenoid valve on the water supply line to open. When the interface board senses that water level in the cookpot is full, (i.e., water contacts the upper water-level sensor), it signals the solenoid valve to close. Anytime the water level in the cookpot drops below the upper water-level sensor, the interface board signals the solenoid valve to open to refill the cookpot to the proper level.

When the HEAT CYCLE switch is placed in either the BOIL or the SIMMER position, if water is in contact with the lower water level sensor, the interface board signals the contactor coil to close, energizing the heating element. If the switch is placed in the SIMMER position, the interface board closes or opens the contactor coil (and thus energizes or de-energizes the element) to maintain the water in the cookpot at the temperature set with the thermostat knob. If the switch is placed in the BOIL mode, the element remains energized until the switch is placed in the IDLE or the SIMMER mode. If the switch is placed in the IDLE mode, power is supplied to all components of the unit except the heating element. The Autofill feature, the faucet switch, and the skim switch are functional anytime the power switch is in the ON position, regardless of the position of the heat cycle switch.

NOTE: The cooker has a high-limit safety. If the water in the cookpot falls below the low-water-level sensor but the sensor remains grounded for whatever reason (thereby allowing the element to continue to heat), the high-limit switch will open when the element temperature reaches $400 \pm 15^\circ\text{F}$. This cuts off power to the element.

Units with Computer Controls

When the computer POWER switch is pressed, a logic circuit in the computer checks the water level in the cookpot. A normally closed solenoid valve on the water supply line automatically opens if the upper water-level sensor is not grounded by contact with water in the cookpot. Water will continue to be added until the upper water level sensor is grounded by contact with water in the cookpot. If there is sufficient water in the cookpot to cover the heating element (i.e., the lower water level sensor is grounded by contact with water in the cookpot), the computer signals the contactor coil to close, thereby energizing the heating element. If the temperature of the water in the cookpot is below the cooking setpoint temperature programmed into the computer, **-°** appears in the computer's LED display. If the temperature of the water in the cookpot is within 11°F (6°C) of the programmed setpoint, “- - -” appears in the computer's LED display.

If the SIMMER mode is selected by pressing the **R** button, logic circuits in the computer monitor the temperature of the water and cycle power to the element on and off to maintain the temperature at the setpoint programmed into the computer. (See Chapter 3 for instructions on adjusting the setpoint.) If the BOIL mode is selected by pressing the **L** button, the heating element remains continuously energized until the SIMMER mode is again selected.

NOTE: The cooker has a high-limit safety. If the water in the cookpot falls below the low-water-level sensor but the sensor remains grounded for whatever reason (thereby allowing the element to continue to heat), the high-limit switch will open when the element temperature reaches $400 \pm 15^\circ\text{F}$. This cuts off power to the element.

The Autoskim feature is activated by placing the SKIM switch in the ON position. When the feature is activated, a logic circuit in the computer automatically opens the solenoid valve in the water supply line for three seconds every minute until the option is turned off by placing the switch in the OFF position.

On units equipped with faucets, the faucet is turned on by placing the FAUCET switch in the ON position. This opens a dedicated normally closed solenoid valve on the faucet water line. The solenoid valve remains open until the switch is placed in the OFF position.

When a product button is pressed to initiate a cooking cycle, the programmed cook time appears in the LED display and begins to count down. When the specified cook time has elapsed, an audible alarm sounds and the associated product button flashes. Simultaneously, logic circuits in the computer activate the appropriate basket lift motor, lowering the basket into the cookpot. As the motor drives the basket lift arm down, a cam attached to the motor eventually loses contact with a roller-activated microswitch and power to the motors is cut. When the computer times out, logic circuits reverse the switch positions so that the motor circuit is again completed and the motor is restarted, raising the basket from the cookpot. At the fully raised position, the cam again makes contact with the microswitch, cutting power to the motor and stopping the lift in the up position.

7.2 Accessing Equipment for Servicing

⚠ DANGER

Moving this equipment while it is filled with hot water may cause spilling or splattering of the hot water. Always drain the cookpot before attempting to relocate this equipment for servicing.

1. Disconnect the unit from the electrical power supply and from the water supply.
2. Remove any attached restraining devices.
3. Relocate the unit for service accessibility.
4. After servicing is complete, reconnect the unit to the water supply, reattach restraining devices, and reconnect the unit to the electrical power supply.

7.3 Replacing Equipment Components

7.3.1 Replacing the Computer

See Section 5.3.

7.3.2 Replacing Electronic Components Other than the Computer

1. Drain the cookpot and disconnect the cooker from the electrical power supply.
2. Remove the cover from the component box. Refer to the illustration below to locate the component to be replaced.

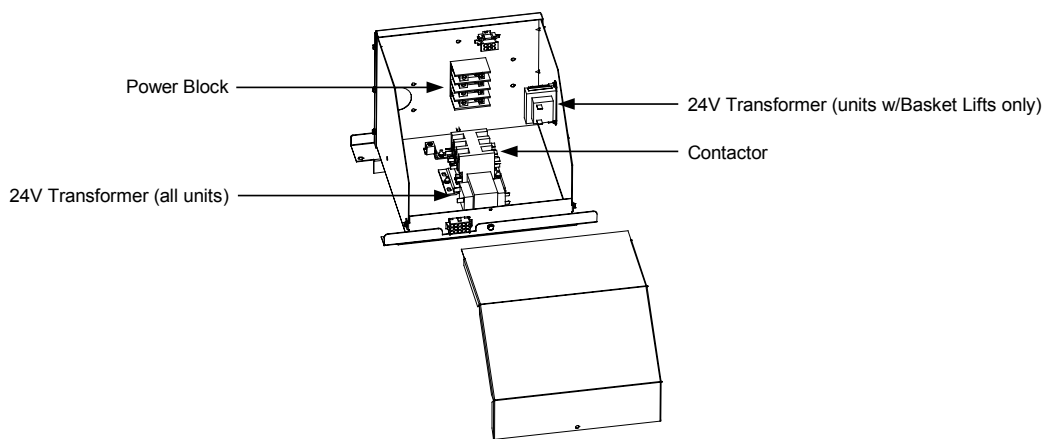

3. On the component to be replaced, make a note of the wiring connection points.
4. Disconnect the wires and remove the failed component. Install the replacement component and reconnect the wiring in accordance with the notes made in Step 3 or with the wiring diagram on the door of the unit.
5. Replace the component box cover, being sure to reconnect the ground wire. Reconnect the cooker to the electrical power supply.

7.3.3 Replacing the Heating Element

1. Drain the cookpot and disconnect the cooker from the electrical power supply. Disconnect the unit from the water supply at the rear of the cooker. Remove the basket lift arms from the unit.
2. Reposition the cooker to allow clear access to the rear of the unit. Remove the cabinet back (on units with basket lifts, remove all three back panels).

3. Unplug the 6-pin element connector from the rear of the contactor box. Depress the locking tabs on each side of the connector and extend it to release the element leads (see photo at right). Pull each of the leads out of the connector, being careful not to damage the connector in the process.

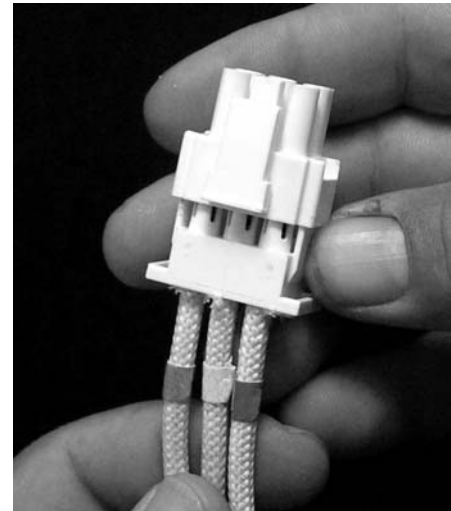

4. If the bundle of element leads is enclosed in a fiberglass insulating sheath, cut the wire ties securing the sheath in place, and remove and discard it; it is no longer required. Inside the cookpot, cut the metal wire ties that secure the high-limit thermostat to the element, being careful not to bend the thermostat in the process.

5. Remove the brass nuts that secure the element in the cookpot and lift the failed element from the cookpot. Recover the Teflon washers from the failed element for use on the replacement.

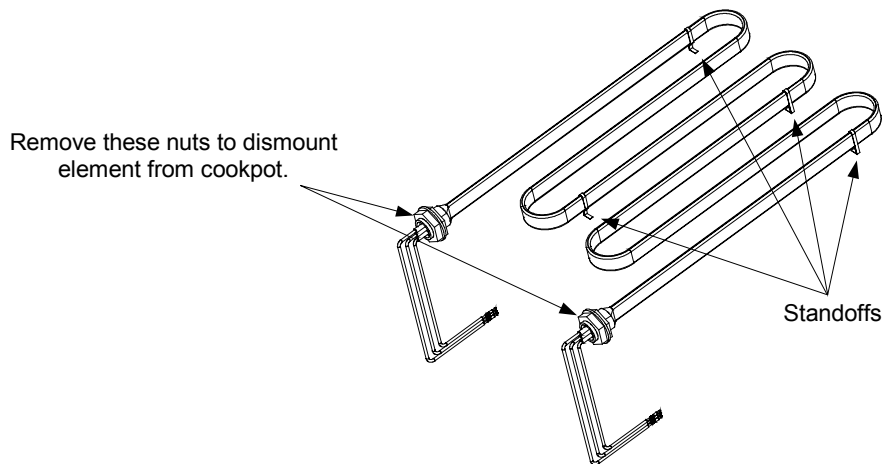

6. Position the replacement element in the cookpot with the standoffs on the bottom of the cookpot. Thread the element leads through the Teflon washers recovered from the failed element. Secure the element in place with the nuts removed in Step 5.
7. Secure the high-limit thermostat against the inside of the leg of the element with two metal wire ties.
8. Insert the pins on the element leads into the element connector in accordance with the illustration on the following page. Each element lead is marked with a number that corresponds to the hole in the connector into which it should be inserted. The insulation on the lead will be flush with the face of the plug when properly positioned. When all leads are positioned correctly, close the connector and verify that the tabs are locked in place.

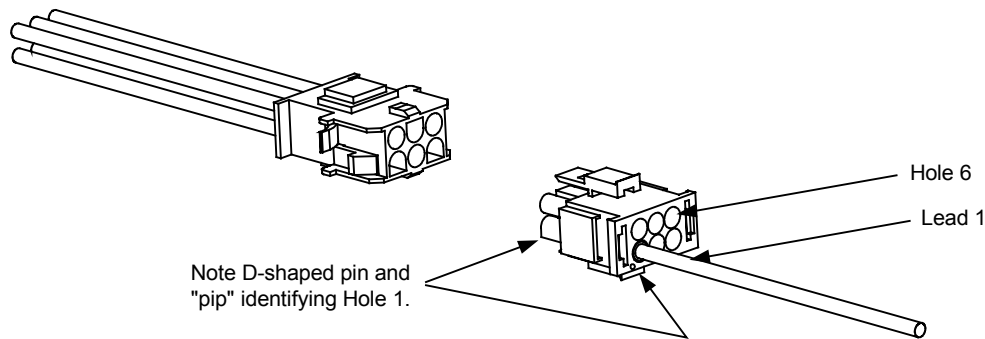

9. Bundle all six element leads together and secure with plastic wire ties close to the element and connector, and in the middle.
10. Plug the connector into the contactor box. Reverse Steps 1 and 2 to complete the procedure.

7.3.4 Replacing the High-Limit Thermostat

1. Drain the cookpot and disconnect the cooker from the electrical power supply. Disconnect the unit from the water supply at the rear of the cooker. If the unit is equipped with basket lifts, remove the basket lift arms. Cut the metal wire ties securing the thermostat tube to the element.
2. Reposition the cooker to allow clear access to the rear of the unit. Remove the cabinet back (on units with basket lifts, remove all three back panels).
3. At the rear of the cookpot, loosen the small compression nut, then unscrew the large fitting from the cookpot. Pull the thermostat tube out through the rear of the cookpot.

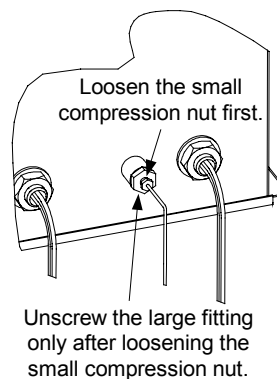

4. Detach the high-limit thermostat leads (5C and 8C) from the thermostat. Remove the two screws securing the thermostat to the mounting bracket and remove the thermostat assembly from the cabinet. (**NOTE:** It is not necessary to remove the bracket.)
5. Loosen the small compression nut in the large fitting on the replacement thermostat so that the large fitting will move freely on the capillary tube (the thin, flexible tube). Carefully insert the replacement thermostat into the cookpot, being careful not to bend the thermostat tube. Position the tube along the inside of the left leg of the element (as viewed from the front of the cooker) and secure it in place with two metal wire ties. Apply thread sealer to the large fitting and screw the fitting securely into the cookpot. When the large fitting is tight, pull gently on the capillary tube to remove any slack, then screw the small compression nut into the large fitting and tighten.

- Coil the capillary tube as necessary to achieve a neat installation and attach the terminal block to the mounting bracket using the screws removed in Step 4. Connect thermostat lead 5C (black) to the normally closed (NC) terminal and 8C (white) to the common (C) terminal.

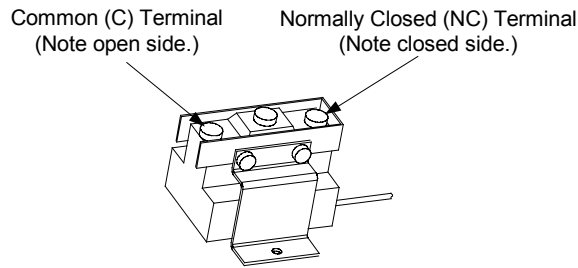

- Reverse Steps 1 and 2 to complete the procedure.

7.3.5 Replacing a Water-Level Sensor

Drain the cookpot and disconnect the cooker from the electrical power supply. Disconnect the sensor lead from the sensor, remove the nuts securing the sensor in place, and remove the sensor. Install the replacement sensor as illustrated below and reconnect the lead.

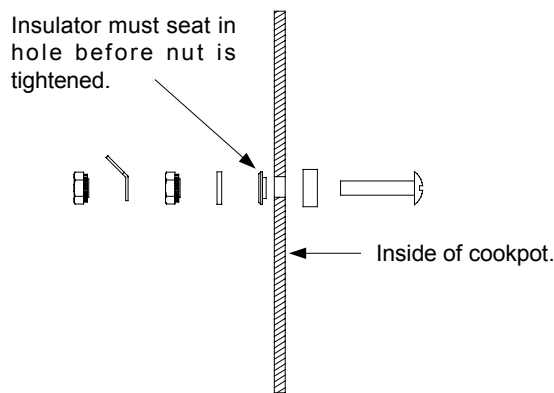

7.3.6 Replacing the Operating Thermostat or Temperature Probe

Units with Manual (Thermostat) Controls

- Drain the cookpot and disconnect the cooker from the electrical power supply.
- Disconnect the rocker-switch wires from the terminals of the thermostat body.
- Loosen the Allen screw in the thermostat control knob and slip the knob off the thermostat shaft. Remove the two screws securing the thermostat body to the mounting bracket and remove the thermostat body from the mounting bracket.
- At the cookpot, loosen the small nut in the center of the temperature probe fitting, then unscrew the fitting from the cookpot. Inside the cookpot, remove the probe cover, push the probe out of its retaining bracket, and withdraw the probe from the cookpot.
- Verify that the small nut in the center of the replacement temperature probe fitting is loose and that the fitting spins easily around the capillary tube. Pass the thermostat bulb through the hole in the cookpot and position it under the lower portion of the retaining bracket.

- Carefully work any slack in the capillary tube back out of the hole in the cookpot. Apply thread sealer to the threads of the replacement temperature probe fitting and screw the fitting into the cookpot. When the fitting is tight, **verify that all slack in the capillary has been worked back out of the cookpot and that the bulb is correctly positioned under the lower portion of the retaining bracket.** Then, and only then, tighten the small nut in the center of the fitting. **NOTE: Tightening the small nut crimps the internal compression fitting onto the capillary and prevents any further movement of the capillary through the large fitting.**

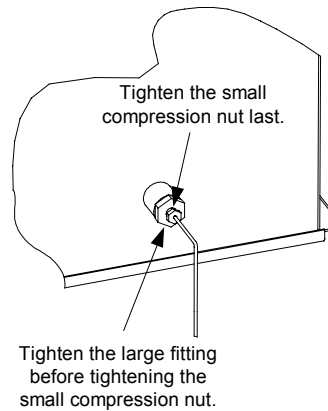

- Position the thermostat body in the mounting bracket with the terminals to the left and reinstall the two screws removed in Step 3. Reinstall the thermostat knob.
- Reconnect rocker-switch wires 20C and 35C to the lower terminal of the thermostat body; reconnect wire 15C to the top terminal. Reinstall the probe cover to complete the procedure.

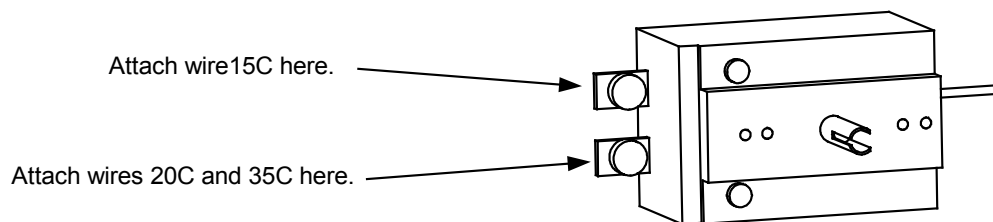

Units with Computer Controls

- Drain the cookpot and disconnect the cooker from the electrical power supply.
- Remove the screws from the upper corners of the control panel and open the panel by allowing it to swing downward.
- Disconnect the 12-pin connector from the interface board and, using a pin pusher, push out the temperature probe leads from holes 6 and 8 on the connector.
- Remove the temperature probe by unscrewing it from the front of the cookpot.
- Apply thread sealer to the replacement probe and screw it securely into the cookpot.
- Insert the probe leads into holes 6 and 8 of the 12-pin connector (there is no polarity; either lead may be inserted into either hole [see illustration at top of next page]). Pull gently on each lead to ensure it is firmly seated.

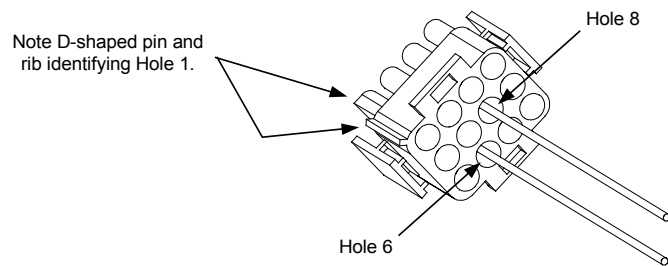

7. Reattach the 12-pin connector to the interface board, close the control panel, and replace the two screws removed in Step 2.

7.3.7 Replacing the Pressure Regulator or Solenoid Valve

1. Drain the cookpot and disconnect the cooker from the electrical power supply. If necessary, reposition the cooker to allow free access to the component to be replaced. Turn off or disconnect the water supply to the cooker. If replacing an Autofill system pressure regulator or solenoid valve on a unit equipped with basket lifts, the basket lift upper rear panel must be removed.
2. Loosen the compression fittings on the water lines running to and from the regulator or solenoid valve and remove the component from the unit. (**NOTE:** If the solenoid valve is mounted adjacent to the regulator, disconnect the solenoid leads and remove both the regulator and solenoid valve from the unit.)

TYPICAL WATER SUPPLY SYSTEM CONFIGURATIONS

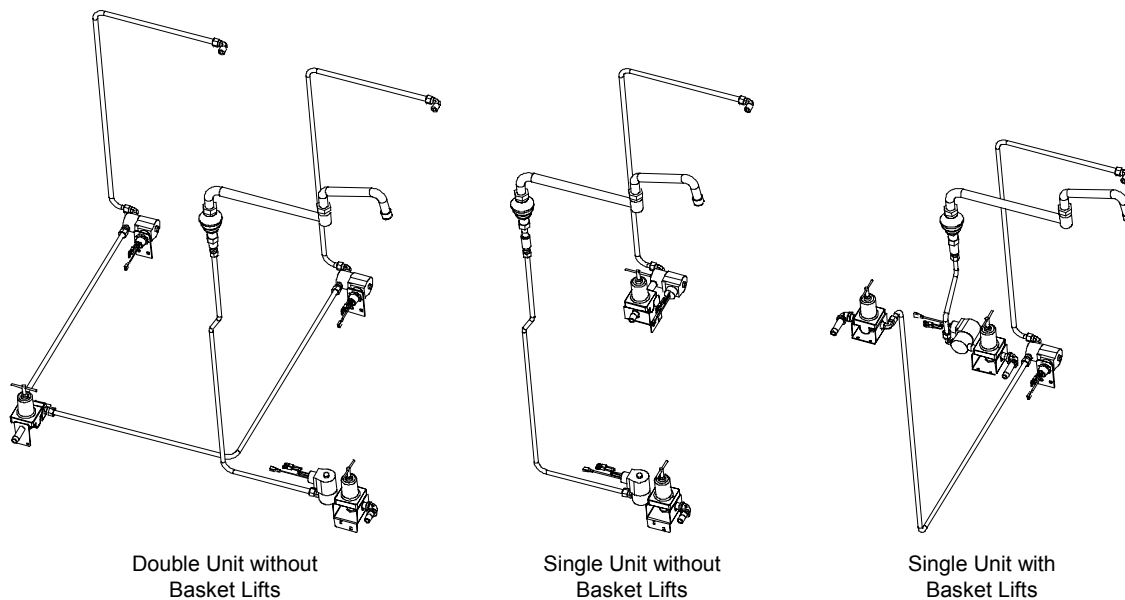

3. If replacing a regulator, adjust the replacement regulator output pressure to not more than 40 PSI (28.15 kg/cm²) before installation in the cooker.
4. Recover the fittings from the failed component (regulator or solenoid valve) and install them on the replacement, using thread sealer on all connections.
5. Reverse Steps 1 and 2 to complete the procedure, being sure to apply thread sealer to all connections.

7.3.8 Replacing the Water Faucet

1. Drain the cookpot and disconnect the cooker from the electrical power supply.
2. Turn off the water supply to the cooker and disconnect the incoming faucet water line where it attaches to the pipe nipple at the pressure regulator. Reposition the cooker to gain clear access to the rear of the cooker.
3. Remove the cabinet back (or, if the unit is equipped with basket lifts, remove the upper rear panel).
4. Disconnect the water supply line at the compression fitting where it attaches to the faucet assembly. Remove the large nut to dismount the faucet assembly from the cabinet.

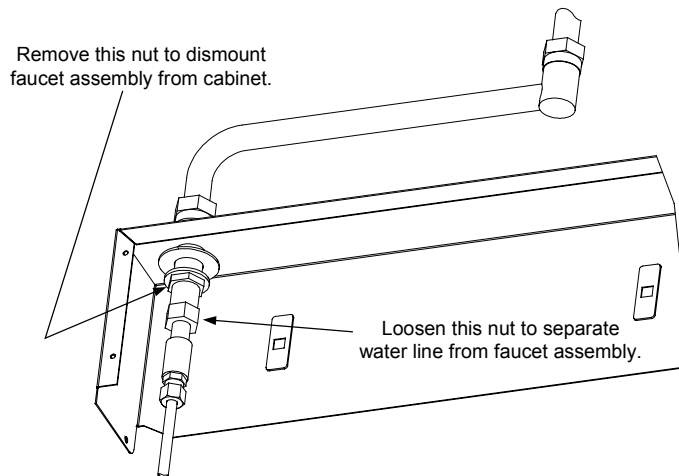

5. Reverse Steps 1-4 to complete the procedure.

7.3.9 Replacing a Basket Lift Motor or Microswitch

1. Disconnect the cooker from the electrical power supply, disconnect the cooker from the incoming water supply, and remove the basket lift arms from the lifter rods.
2. Remove the screws from the upper corners of the control panel and open the panel by allowing it to swing downward. Unplug the basket lift wiring harness from the 5-pin connector on the interface board.
3. Reposition the cooker to gain access to the rear. Remove all three panels from the rear of the basket lift housing, and disconnect the lifter rods from the lifter cams (bell cranks). Slip the lifter rods down and out of the assembly.

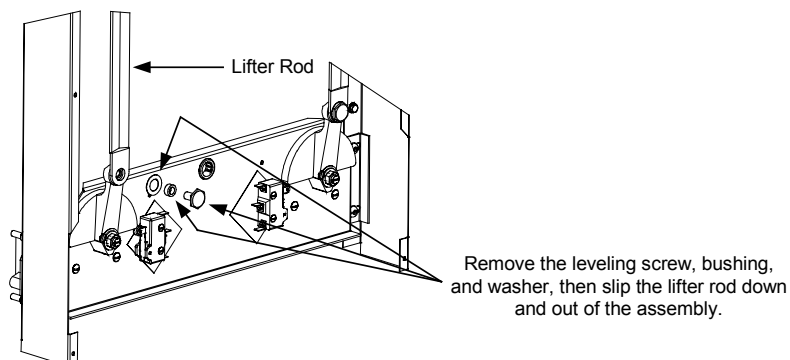

4. Remove the four bolts securing the motor mount to the frame, then remove the motor and mount assembly from the unit. **NOTE:** It is possible to replace a motor or the microswitch without removing the motor and mount assembly, but it is much more difficult.
5. Dismount the motor or microswitch as shown below and install the replacement.

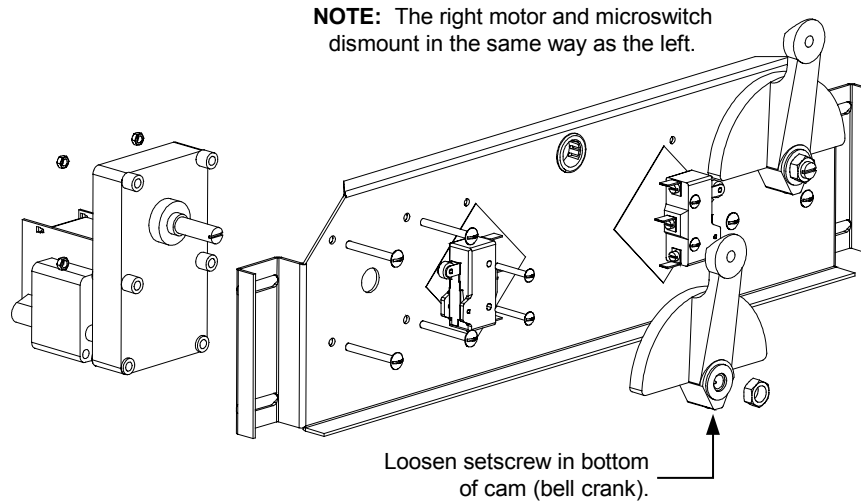

6. Reverse Steps 1-4 to complete the procedure.

7.3.10 Replacing the Cookpot

1. Drain the cookpot and disconnect the unit from the electrical power supply.
2. If so equipped, remove the faucet assembly from the cooker in accordance with Steps 1-4 of Section 7.3.8.
3. Remove the screws from the upper corners of the control panel and open the panel by swinging it downward.

On units with manual (thermostat) controls:

- a. Disconnect the water level sensor leads at the cookpot terminals. Disconnect all wiring from the control panel switches and light, and then remove the control panel from the unit.
- b. Unplug the 4- and 6-pin connectors from the interface board. Disconnect all wiring from the terminal block mounted next to the interface board.
- c. Remove the interface board bracket from the unit.
- d. Remove the temperature probe from the cookpot in accordance with Steps 4 through 6 of Section 7.3.6 (Units with Manual (Thermostat) Controls).
- e. Remove the thermostat mounting bracket with thermostat attached.

On units with computer controls:

- a. Disconnect the water level sensor leads at the cookpot terminals. Disconnect all wiring to the Skim switch (and to the Faucet switch, if present). Unplug the 15-pin connector from the rear of the computer, and then remove the control panel from the unit.

- b. Unplug the 5- and 12-pin connectors from the interface board. Do not disconnect the water level sensor leads from the interface board.
 - c. Remove the interface board bracket from the unit.
 - d. Using a pin pusher, push out the temperature probe leads from holes 6 and 8 on the 12-pin connector.
4. Disconnect the Autofill water supply piping at the cookpot compression fitting.
 5. Remove the screws that secure the topcap to the cabinet and remove the topcap from the unit. On double units, remove the cookpot connecting strip.
 6. Remove the screws attaching the standoff brackets to the cookpot.

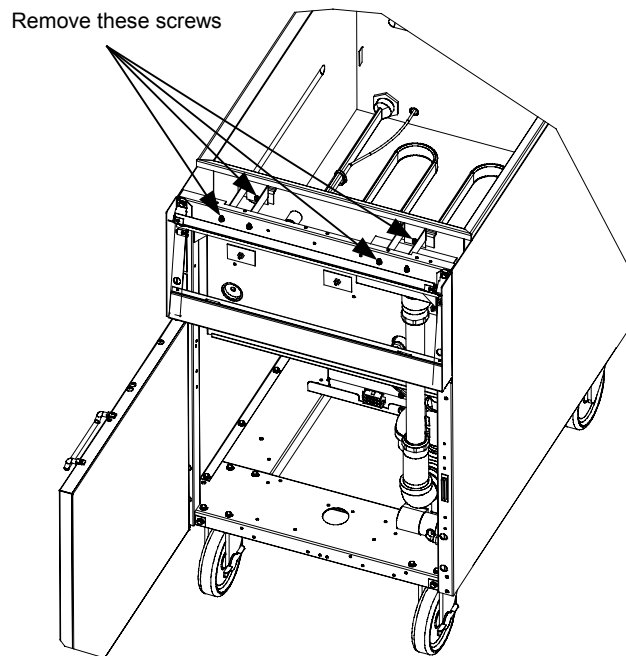

7. Unplug the element wiring harnesses from the rear of the contactor box. Disconnect the high-limit thermostat leads from the thermostat body. Remove the screws securing the backsplash to the cabinet and remove the backsplash.
8. With an assistant, lift the cookpot straight up and out of the cabinet. **DO NOT ATTEMPT TO REMOVE THE COOKPOT WITHOUT ASSISTANCE!**
9. Invert the cookpot on a suitable work surface and remove the salvageable components (e.g., insulation, element, thermostats, drain plumbing, etc.). Install the recovered components on the replacement cookpot or rinse tank, using thread sealer on all connections.
10. Reverse Steps 1 through 8 to complete the procedure, referring to the wiring diagram on the door of the unit or at the end of this chapter when reconnecting wiring.

7.4 Troubleshooting

Problems with this equipment may be grouped into five broad categories:

1. Failure or malfunction of a 24VAC Power-Supply System component.
2. Failure or malfunction of a Control System component.
3. Failure or malfunction of an Autofill/Autoskim System component.
4. Failure or malfunction of a Water Heating System component.
5. Failure or malfunction of a Basket Lift System component (on units so equipped).

Sections 7.4.1 through 7.4.5 briefly explain the functioning of each of the systems mentioned above. Section 7.4.6 contains troubleshooting guides that provide systematic procedures to isolate and identify the specific source of a problem. Wiring diagrams are located at the end of the chapter.

7.4.1 How the Power-Supply System Works

Line voltage is supplied to the system via a power cord that is plugged or hard-wired into the store's electrical service. The power cord is attached to a three-lug power terminal block. One set of three wires delivers line voltage from the load side of the block to the line side of the contactor. A second set of two wires delivers line voltage to the 24VAC transformer. Line voltage for the heating element is delivered from the load side of the contactor through the 6-pin connector on the rear of the contactor box. 24VAC for the remaining components is distributed to and from the contactor box via the 15-pin connector on the front of the box.

On units with basket lifts, a separate set of two wires delivers line voltage from the terminal block to the basket lift 24VAC transformer. From the transformer, the 24VAC is delivered to the interface board via the 12-pin connector on the interface board. Line voltage for one side of the basket-lift-motor circuits is delivered directly to the motors from the terminal block via the 15-pin connector on the front of the contactor box. Line voltage for the other side of the basket-lift-motor circuits is supplied via the basket lift relays mounted on the interface board through the 5-pin connector on the interface board. All line and 24VAC power except the line voltage for the elements is distributed to and from the contactor box via the 15-pin connector on the front of the box.

7.4.2 How the Computer Works

The CM III computer provides the interface between the operator and the system components. 24VAC from the transformer is supplied through Pin 7 of the 9-pin connector on the interface board. The 24VAC is rectified to 12VDC and delivered to the computer via Pins 1 and 3 of the 15-pin connector. Internal circuitry senses the water temperature. Depending upon the conditions sensed, the computer energizes or de-energizes the heating element (via the contactor coil) to control water temperature. The computer also controls the lowering and raising of the basket lifts, and activates an audible alarm to signal the operator that a cooking cycle has completed. The computer signals for heat via Pin 4 of the 15-pin connector. The temperature probe connects to Pins 13 and 14 of the 15-pin connector. The basket lift relays connect to Pins 7 (right) and 9 (left), and the sound device connects to Pin 11 of the 15-pin connector.

7.4.3 How the Autofill and Skim Systems Work

The heart of the automatic filling (Autofill) system is a normally closed solenoid valve that opens when 24VAC is applied as a result of the loss of upper water-level sensor ground. The ground is lost when the sensor is not in contact with water in the cookpot. Starch or lime build-up on the sensor may keep a ground from forming. Therefore always make sure the sensor is clean and its lead is firmly connected to Pin 1 of the 6-pin connector on the interface board (units with **manual controls**) or connector J5 on the interface board (units with **computer controls**). Also, in order for the ground to form, there must be some mineral content in the water (pure water is non-conductive). Consequently, the units will not operate with distilled water. If distilled, highly filtered, or purified water is used, add 1/8-cup of baking soda to the water each time the cookpot is emptied and refilled.

In units with manual controls, the 24VAC is supplied via Pins 1 and 2 of the 4-pin connector on the interface board so long as the upper water-level sensor is not in contact with the water in the cookpot. **In units with computer controls**, 24VAC is continuously supplied to one leg of the circuit via Pin 6 of the 15-pin connector on the front of the contactor box. The other leg is supplied via Pin 2 of the 12-pin connector on the interface board so long as the upper water-level sensor is not in contact with water in the cookpot. In either case, when the water in the cookpot reaches the upper water-level sensor, the sensor is grounded. This causes logic circuits in the interface board to cut the 24VAC to the solenoid, closing the valve.

If the SKIM switch is placed in the ON position, the logic circuits in the interface board are bypassed and 24VAC is applied to the solenoid valve for as long as the switch is left in the ON position.

7.4.4 How the Water Heating System Works

To prevent energizing the heating elements when there is no water in the cookpot, these units are equipped with a **low-water-level sensor**. This sensor must be grounded by contact with water in the cookpot before the control circuitry will apply power to the elements. Starch or lime build-up on the low-water-level sensor may keep the ground from forming, therefore always make sure the sensor is clean and its lead is firmly connected to J5 on the interface board. In order for the ground to form, there must be some mineral content in the water (pure water is non-conductive). Consequently, the units will not operate with distilled water. If distilled, highly filtered, or purified water is used, add 1/8-cup of baking soda to the water each time the cookpot is emptied and refilled.

In addition to the low-water-level sensor discussed above, the water heating system has six more parts: the high-limit thermostat, the temperature probe, the contactor, the element, and a HEAT CYCLE switch and manual thermostat, or a computer.

The **high-limit thermostat** functions as a normally closed switch. If the water in the cookpot falls below the low-water-level sensor but the sensor remains grounded (for whatever reason), the high-limit switch will open when the element temperature reaches 400°F ±15 (204°C ± 9). This cuts power to the contactor coil and thus to the element.

The **temperature probe** is used only when the unit is in the simmer mode. When the operator selects the simmer mode, logic circuits in the on the interface board or in the computer monitor the temperature of the water and cycle power to the element (via the contactor coil) on and off as

required to maintain the temperature at the setpoint programmed into the computer or set on the thermostat knob.

The **contactor** is the terminal block to which the element leads are connected and where actual contact is made between the leads and the line voltage. Built into the contactor is a 24VAC coil that energizes when signaled by the computer or interface board that the water temperature is below the setpoint. When it energizes, contact is made between the incoming line voltage and the element leads, and line voltage is supplied to the element.

The **element** is a resistive heating device. That is, when voltage is applied to the element, it gets very hot due to its resistance to current flow through it. The heat generated is transferred directly to the water in which the element is immersed.

In units with **manual** controls, the three-position HEAT CYCLE switch controls how power is supplied to the element. When the switch is in the:

- **IDLE** position, no power is supplied to the element at any time.
- **BOIL** position, power is supplied to the element continuously until the switch is placed in another position.
- **SIMMER** position, power to the element cycles on if the water temperature is below the temperature indicated by the thermostat knob. When the temperature reaches that indicated by the thermostat knob, power to the element cycles off. This process continues until the switch is placed in another position.

In units equipped with a **computer**, the computer is the interface between the operator and the other components of the equipment. It controls the application of line voltage to the heating element via the contactor. There are two modes of operation:

Simmer Mode, the signal from the computer is continuous and line voltage is applied to the elements until the simmer setpoint programmed into the computer is reached, at which time the signal ceases.

Boil Mode, the signal from the computer is continuous ceasing only when the unit is turned off or placed in the simmer mode.

7.4.5 How the Basket Lift System Works

When a product button is pressed to start the cooking cycle, logic circuits in the computer activate the appropriate basket lift motor, lowering the basket into the cookpot. As the motor drives the basket lift rod down, a cam attached to the motor eventually loses contact with a roller-activated microswitch and power to the motor is cut. When the computer times out, logic circuits reverse the switch positions so that the motor circuit is again completed and the motor is restarted, raising the basket from the cookpot. At the fully raised position, the cam again makes contact with the microswitch, cutting power to the motor and stopping the lift in the up position.

7.4.6 Technician Troubleshooting Guides

TROUBLESHOOTING THE 24VAC POWER SUPPLY SYSTEM

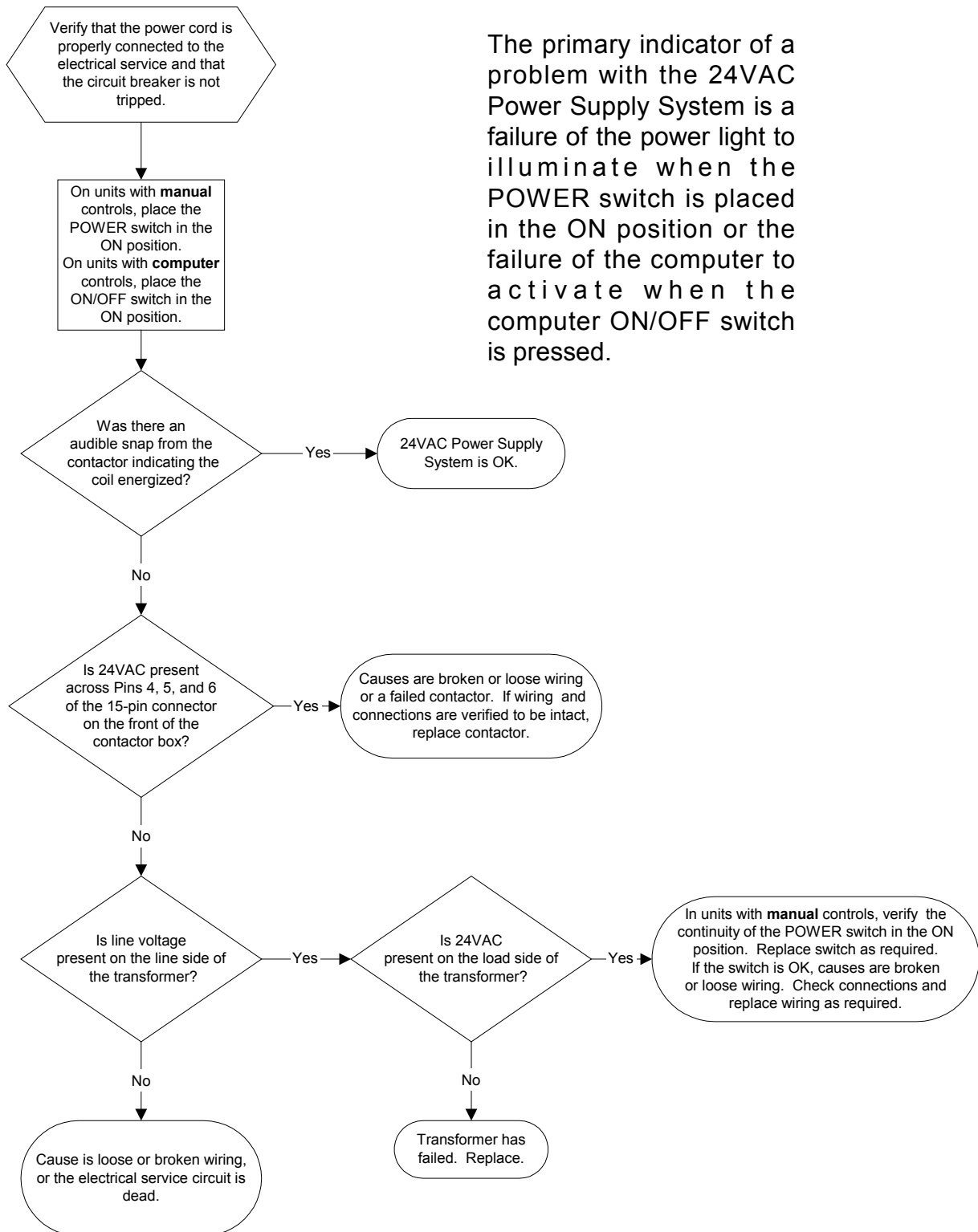

TROUBLESHOOTING THE AUTOFILL SYSTEM

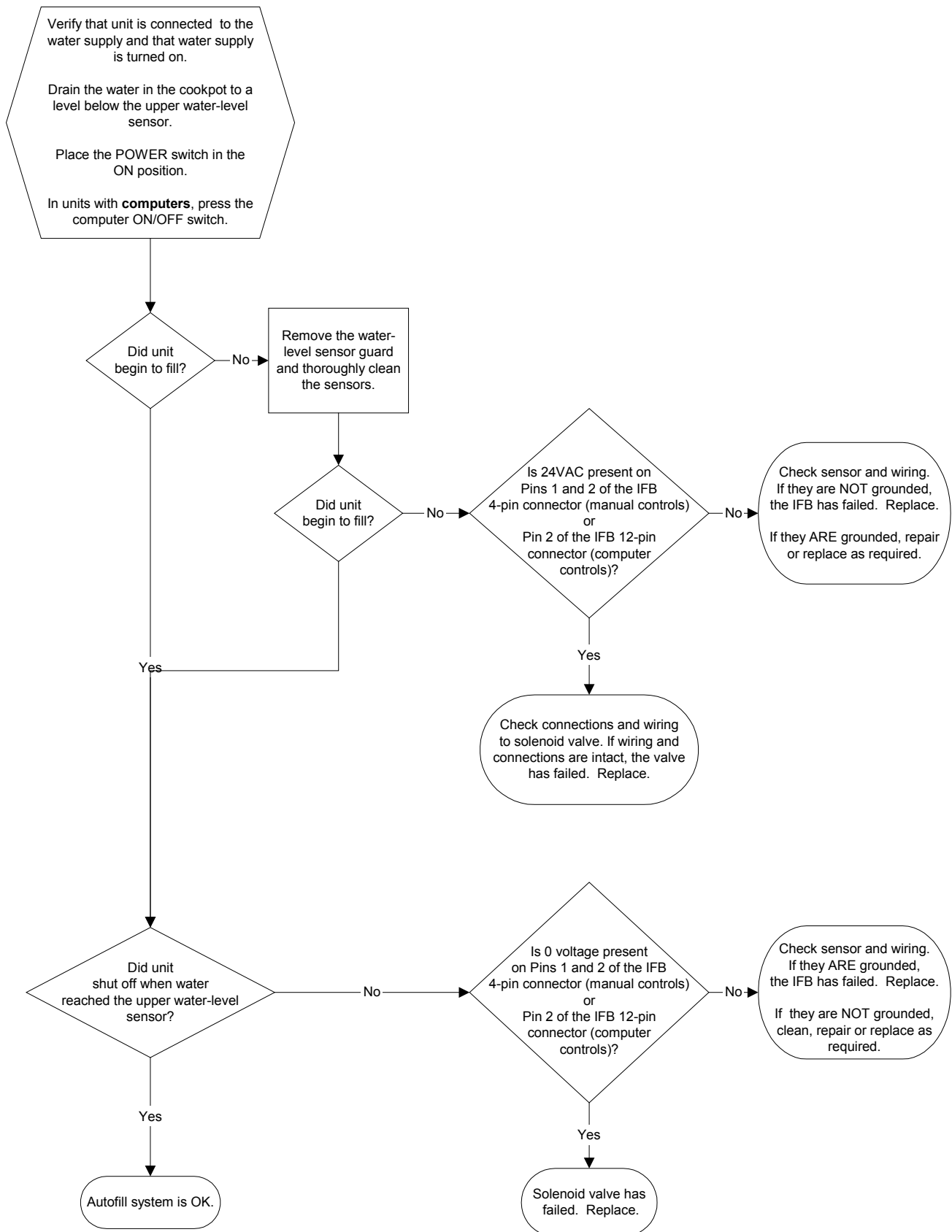

TROUBLESHOOTING THE WATER HEATING SYSTEM

Each of the following checks is to be performed with the unit connected to the electrical power supply, with the unit ON and calling for heat, and with at least enough water in the cookpot to cover the lower water-level sensor.

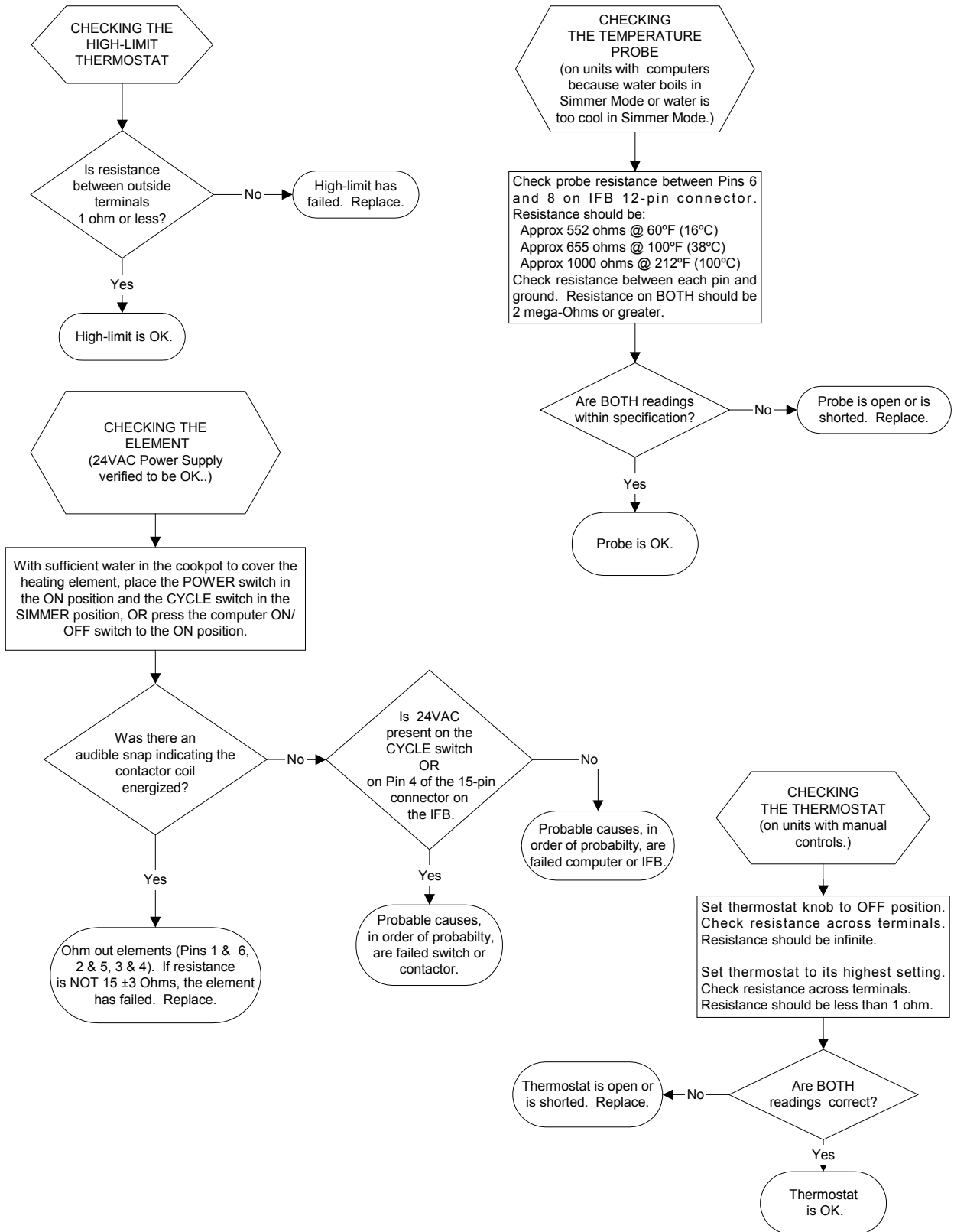

TROUBLESHOOTING THE BASKET LIFT SYSTEM

If the basket lift motors are activating, but the basket lift fails to raise or lower, or if its movement is erratic, the probable cause is jamming or binding of the basket lift rods. Apply a light-weight white grease (such as Lubriplate™) to the rods. If this does not correct the problem, check for bent or otherwise damaged rods and links, and for loose bellcranks.

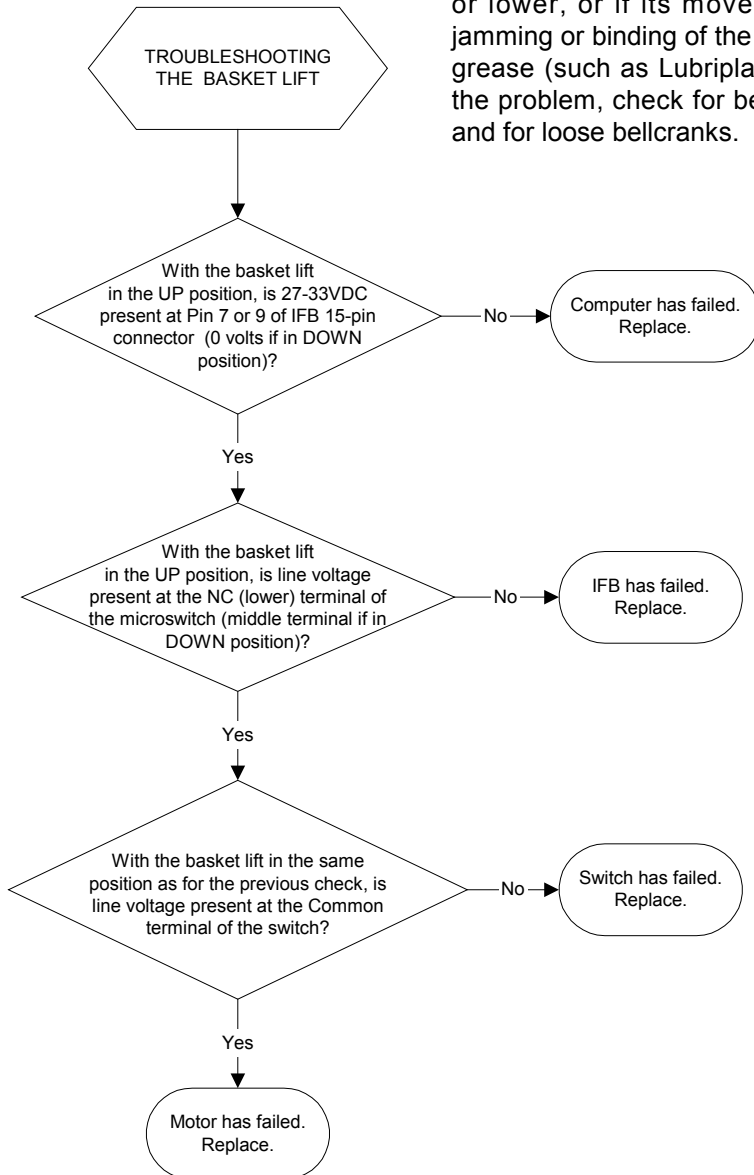

7.5 Parts List

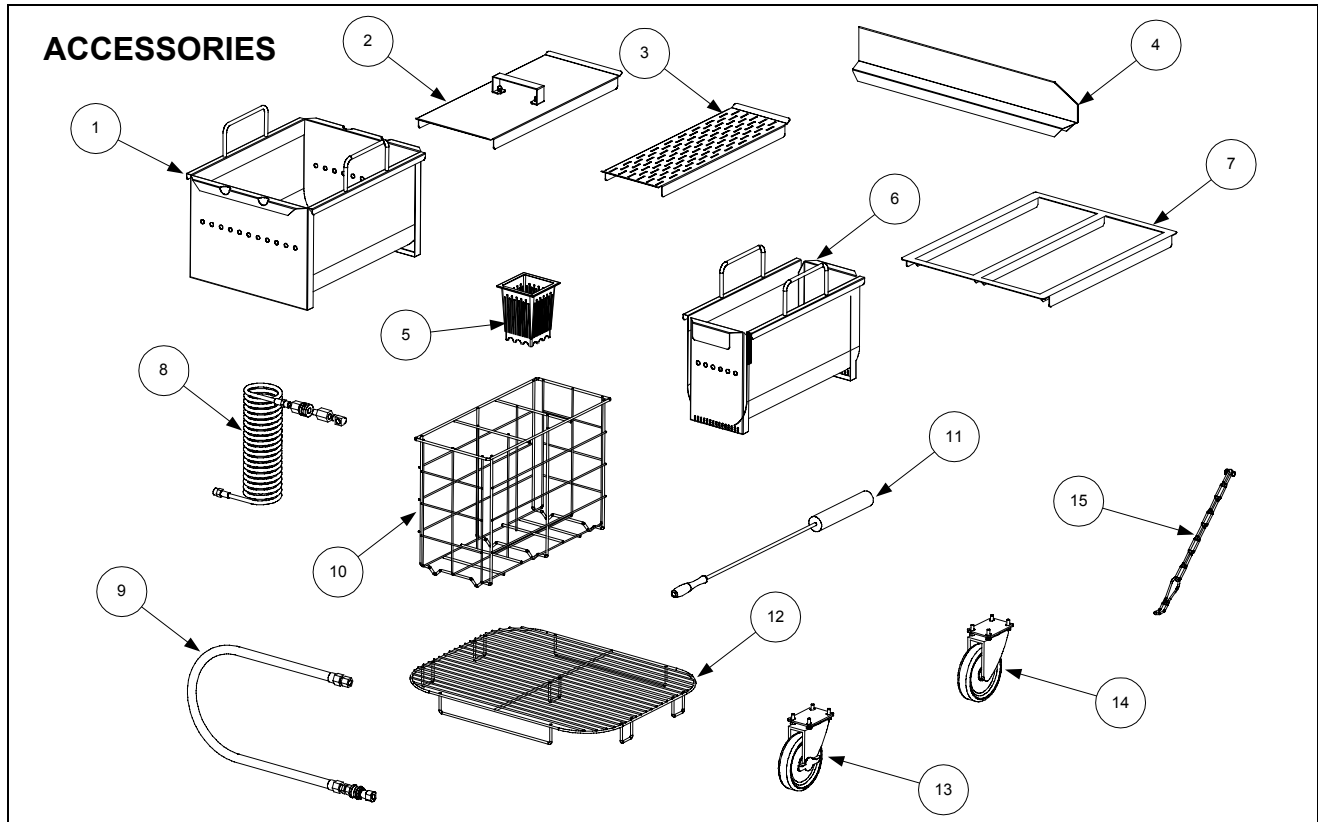

ITEM	PART #	COMPONENT
1	823-1910	Basket, Bulk Cooking, Full Size (cannot be used with basket lifts)
2	806-7569	Cover
3	910-2545	Strainer Board
4	824-0587	Cookpot Top Connecting Strip (used on double units only)
5		Cup, Single Portion
	803-0018	Beige
	803-0260	White
6	823-2754	Basket, Bulk Cooking, Half Size (for use with basket lifts)
7	910-2766	Pan Insert
8	810-1008	Hose, Water Supply, with Quick Disconnect Fittings (Swirl)
9	810-1463	Hose, Water Supply, with Quick Disconnect Fittings
10	803-0155	Basket, Sauce Packet
11	803-0234	Brush, Probe Cleaning
12	803-0233	Rack, Basket Support
13	826-1117	Caster without Brake, 5-Inch (includes mounting hardware)
14	826-1118	Caster with Brake, 5-Inch (includes mounting hardware)
15	826-0900	Chain Restraint Kit
*	803-0259	Rack, 4 Portion Cups (for use with basket lifts)
*	803-0218	Rack, 9 Portion Cups (cannot be used with basket lifts)

* Not illustrated.

BASKET LIFT COMPONENTS

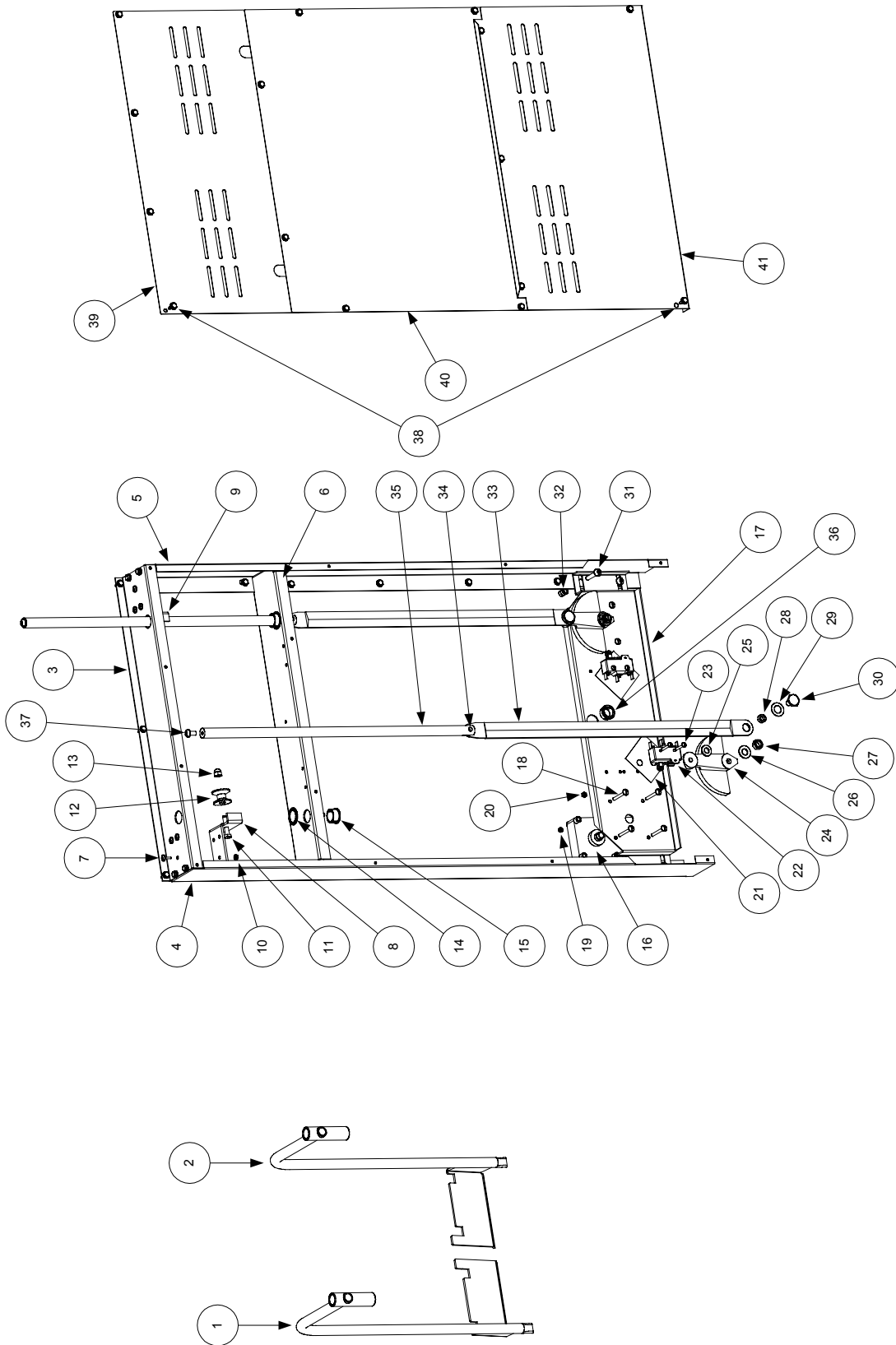

ITEM	PART #	COMPONENT
1	823-2753	Arm, Right Basket Lift (as viewed from front of unit)
2	823-2752	Arm, Left Basket Lift (as viewed from front of unit)
3	910-7420	Top, Basket Lift Enclosure
4	911-7417	Side, Basket Lift Enclosure Right
5	912-7417	Side, Basket Lift Enclosure Left
6	900-7421	Support, Basket Lift Rod Bushing
7	826-1363	Screw, 8-32 x ½-inch Slotted Truss Head (Pkg of 25)
8	902-1927	Bracket, Left Basket Lift Roller
9	901-1927	Bracket, Right Basket Lift Roller
10	809-0247	Nut, 8-32 Hex Keps
11	809-0508	Bolt, ¼ -20 x 1 ¼-inch Hex Head SS
12	810-0194	Roller, Basket Lift
13	809-0047	Nut, ¼-20 SS Hex Cap
14	809-0082	Ring, ¾-inch Truarc
15	810-0045	Bushing, Basket Lift Rod
16	807-0108	Motor, 240VAC Basket Lift
17	900-7416	Mount, Basket Lift Motor
18	809-0113	Screw, 8-32 x 1 ½-inch Slotted Truss Head
19	809-0050	Nut, 8-32 Hex
20	826-1358	Nut, 6-32 Hex (Pkg of 25)
21	812-0138	Insulation, Motor Mount (Fishpaper)
22	807-0240	Microswitch
23	809-0097	Screw, 6-32 x 1-inch Slotted Truss Head
24	810-0052	Cam (Bellcrank), Basket Lift
25	809-0194	Washer, 5/16-inch SAE Flat
26	809-0196	Washer, ⅜-inch SAE Flat
27	809-0063	Nut, Jam 3/8-16 Hex
28	810-0220	Spacer, Tubular, .493-inch OD
29	809-0203	Washer, ½-inch ID x ⅞-inch OD Nylatron Flat (Pkg of 10)
30	809-0155	Screw, 5/16-18 x ⅝-inch Leveling
31	826-1370	Screw, ¼-20 x 1 ¼-inch Slotted Round Head (Pkg of 10)
32	809-0076	Nut, ¼-20 x ¾-inch Expansion
33	920-6076	Link, Basket Lift
34	810-0170	Pin, ¼-inch x ⅝-inch Spring Dowel
35	810-0192	Rod, 19 ⅝-inch Basket Lift
36	807-0124	Bushing, Heyco
37	809-0127	Screw, ¼-20 x ½-inch Slotted Round Head
38	809-0719	Screw, #10 x ½-inch 410SS
39	900-8063	Panel, Upper Basket Lift Rear
40	900-7995	Panel, Middle Basket Lift Rear
41	900-7419	Panel, Lower Basket Lift Rear

CABINETS

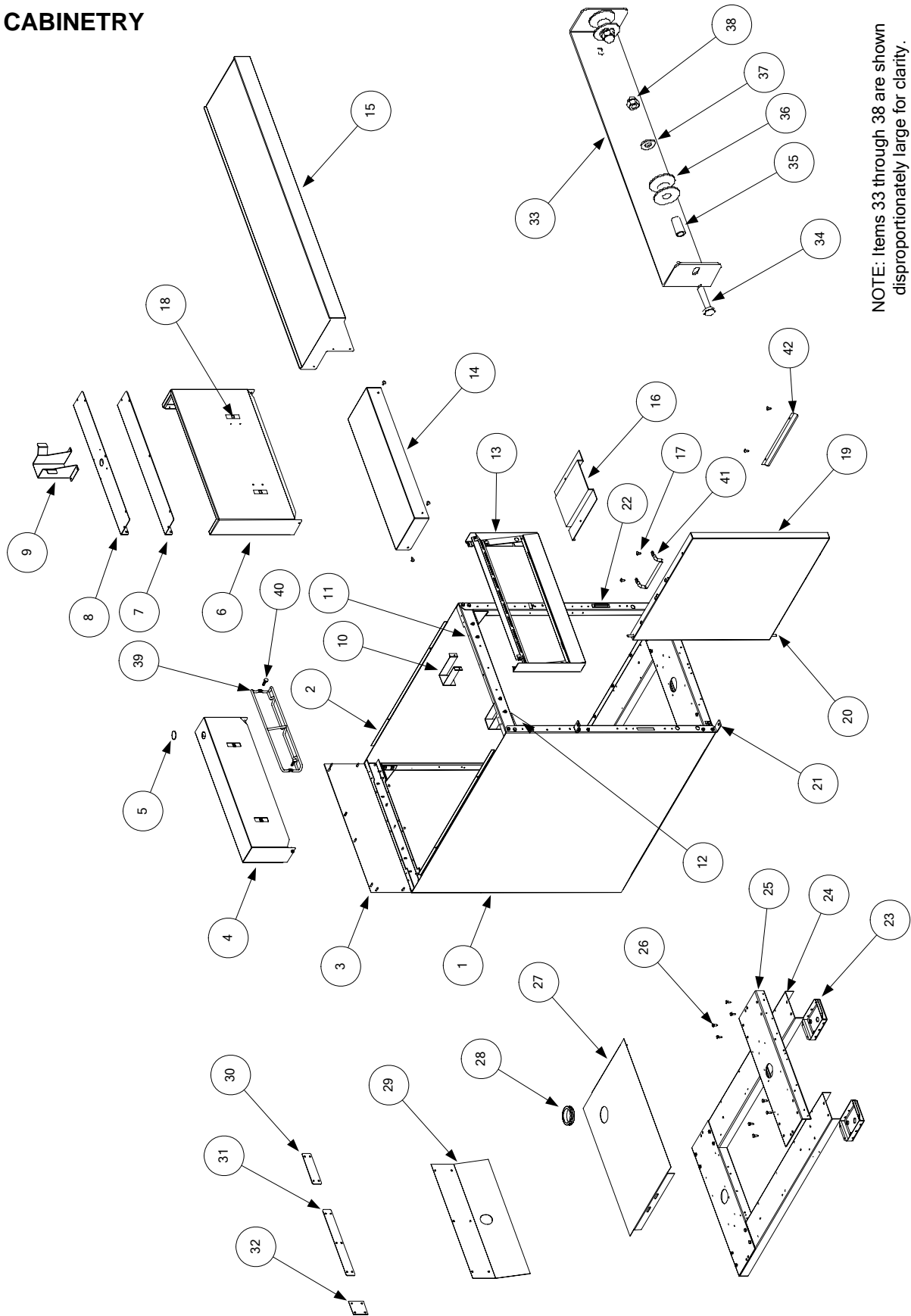

NOTE: Items 33 through 38 are shown disproportionately large for clarity.

ITEM	PART #	COMPONENT
1		Side, Left or Right Cabinet
	910-7377	Stainless Steel
	900-7377	Cold Rolled Steel (Painted)
2	910-2914	Side, Double Unit Inner Cabinet
3	900-5023	Back, Cabinet
4	824-0633	Backsplash (units without basket lifts)
5	810-0044	Plug, 7/8-inch (used on units without basket lifts or faucets)
6	823-2105	Backsplash (used on units with basket lifts)
7	910-8355	Cover, Backsplash Top (used on basket lift units without faucet)
8	910-8060	Cover, Backsplash Top (used on basket lift units with faucet)
9	910-8058	Restrictor, Faucet Rotation (used on basket lift units with faucet)
10	900-1759	Bracket, Pot Hold Down
11	900-4654	Brace, Top
12	900-1552	Gusset (Corner Brace)
13	806-5260	Frame, Control Panel
14	910-7541	Topcap
15	823-2351	Topcap, Plate-Width (used on double units only)
16	900-2762	Support, Plate-Width Topcap
17	809-0266	Screw, #10 x 1/2-inch Phillips Truss Head (door panel and handle screw)
18	826-1351	Retainer, 1/4-20 Nut (Nutsert) (Pkg of 10)
19	806-3853	Door Assembly, Left or Right (does not include handle or hinges)
20	806-4487	Door Pin Assembly
21	810-1508	Hinge, Universal Door
*	826-1343	Spring, Door Hinge (Pkg of 10)
22	810-1105	Magnet, Door
23	806-5209	Leg Pad Assembly
24	900-7528	Channel, Left or Right Side Base
25	900-4655	Channel, Front or Rear Base
26	826-1374	Screw, #10 x 1/2-inch Washer Hex Head (Pkg of 25)
27	900-8273	Moisture Shield
28	816-0091	Grommet, 1 1/4-inch Drain
29	900-4645	Shield, Heat
30	910-5137	Plate, Battering (4.7-inch x 1.2-inch with 4 holes)
31	910-3122	Plate, Battering (10-inch x 1.2-inch with 6 holes)
32	910-0404	Plate, Battering (2-inch x 2-inch with 4 holes)
33	910-4831	Bracket, Basket Lift Roller
*	809-0127	Screw, 1/4-20 x 1/2-inch Slotted Round Head (for mounting Item 33)
34	809-0508	Bolt, 1/4-20 x 1 1/4-inch Hex Head
35	810-0374	Spacer, Basket Lift Roller Tubular
36	810-0194	Roller, Basket Lift
37	809-0190	Washer, 1/4-inch SS Flat
38	809-0047	Nut, 1/4-20 Hex Head Cap
39	810-2229	Hanger, Basket (replaced extruded aluminum hanger 803-0028, which is no longer available.)
40	809-0171	Thumbscrew, Basket Hanger
41	810-1402	Handle, Wire Form Door (<i>cannot replace 210-9214</i>)
42	210-9214	Handle, Eurolook Door (<i>cannot replace 810-1402</i>)

* Not illustrated.

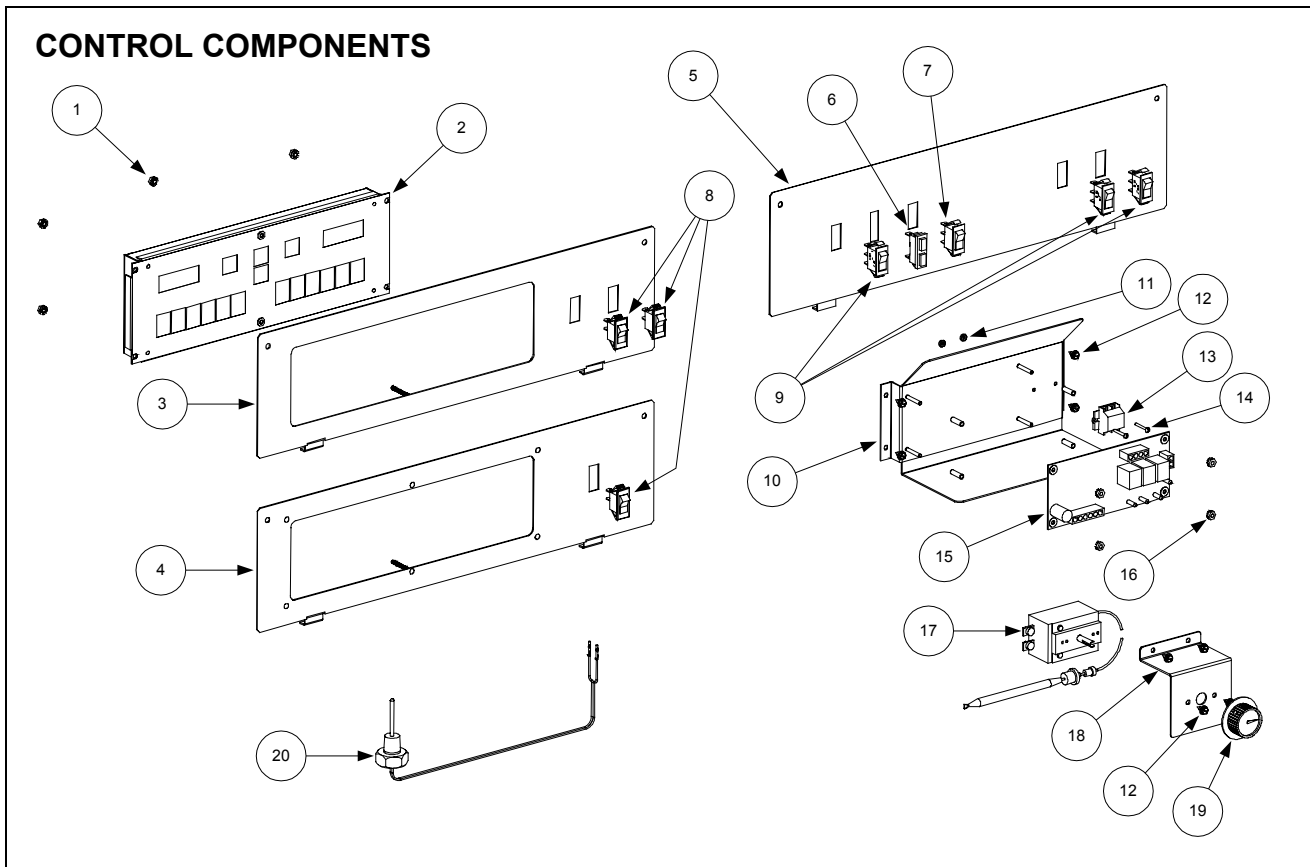

ITEM	PART #	COMPONENT
1	809-0250	Nut, 6-32 Hex Head Keys
2	806-9100	Computer, CM III (for use on EWBS units only)
3	823-2760	Panel, Computer Control with Two Cutouts
4	823-2770	Panel, Computer Control with One Cutout
5	910-2454	Panel, Manual (Thermostat) Control
6	807-0495	Light, Red and White Split, 24V
7	807-2479	Switch, ON-OFF-ON Rocker (Non-Illuminating)
8	807-2082	Switch, ON-OFF Rocker (Non-Illuminating)
9	807-2273	Switch, ON-OFF Rocker (Non-Illuminating)
10	806-9413	Bracket, Interface Board Mounting
11	809-0238	Nut, 4-40 Hex Head
12	809-0360	Screw, #8 x 3/8-inch Washer Slotted Hex Head
13	810-1164	Block, Screwless Terminal
14	809-0354	Screw, 4-40 x 3/4-inch Slotted Pan Head
15		Interface Board
	806-6505	For use on units with manual (thermostat) controls.
	806-9295	For use on units with computer.
16	809-0250	Nut, 6-32 Hex Head Keys
17	807-2272	Thermostat, Operating
18	900-5026	Bracket, Thermostat Mounting
19	810-0387	Knob, Control
*	802-1432C	Label, Thermostat Dial (adhesive-backed)
20	806-4206	Probe, Temperature (for use on units with computers)

* Not illustrated.

COOKPOT AND DRAIN COMPONENTS

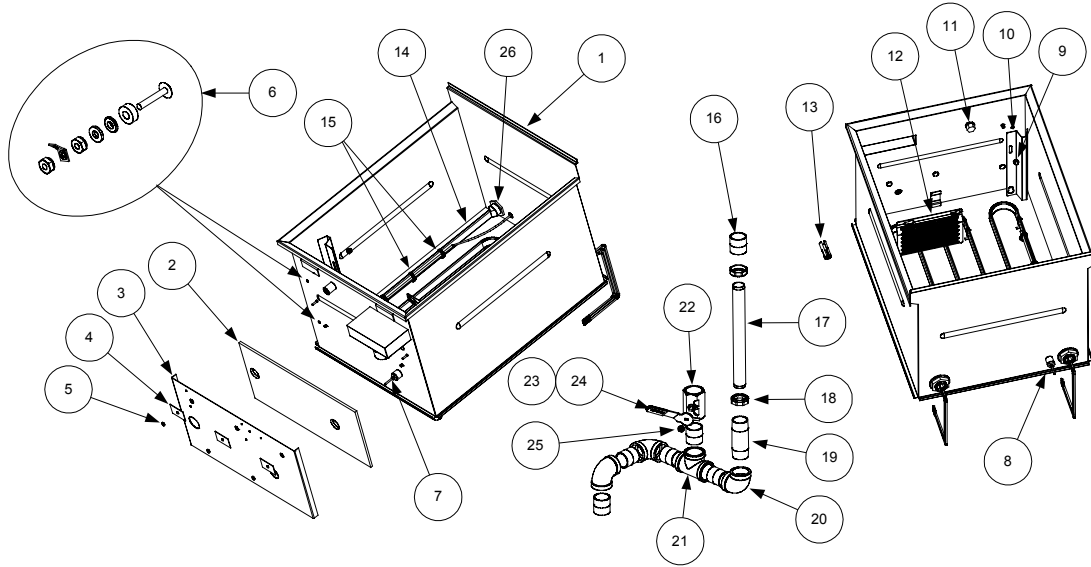

ITEM	PART #	COMPONENT
1		Cookpot
	823-2392SP	Units with Manual Controls
	823-2757SP	Units with Computers
2	816-0152	Insulation, Cookpot Front
3	900-5405	Retainer, Cookpot Front Insulation
4	900-1762	Retainer, Insulation
5	826-1376	Nut, 10-32 Hex Head Keps (Pkg of 10)
6	806-7552SP	Water-Level Sensor Assembly
7		Temperature Sensor
	807-2272	Operating Thermostat (units with manual controls)
	806-4206	Temperature Probe (units with computers)
8	807-2466	High-Limit Thermostat
9	809-0047	Nut, 1/4-20 Cap
10	910-2927	Cover, Water-Level Sensor
11	810-0976	Nozzle
12	910-1038	Thermostat Guard (units with manual controls)
13	810-0738	Probe Guard (units with computers)
14	807-2440	Element, 208V 13kW Heating
15	809-0567	Tie Wrap, Metal
16	813-0391	Nipple, 1/4-inch NPT Close
17	813-0451	Nipple, 1/4-inch NPT x 12-inch Chromed Brass
18	813-0453	Nut, 1/4-inch NPT Chromed Stainless Steel Slip
19	813-0146	Nipple, 1/4-inch NPT x 4/4-inch
20	813-0070	Elbow, 1/4-inch NPT 90°
21	813-0394	Tee, 1/4-inch NPT
22	810-1825	Valve 1/4-inch NPT Drain
23	814-0047	Sleeve, Red Drain Valve Handle
24	910-9527	Handle, Drain Valve
25	809-0063	Nut, 3/8-16 Jam
26	809-0204	Washer, Teflon (between element and inside face of cookpot)

ELECTRONICS

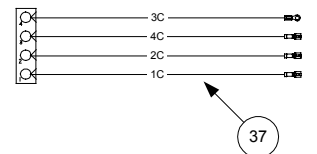
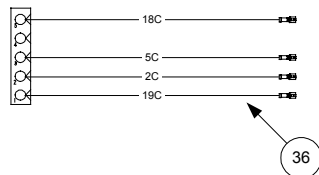
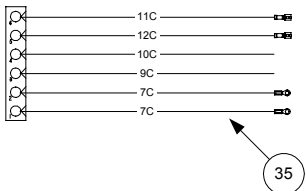
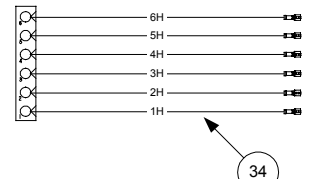
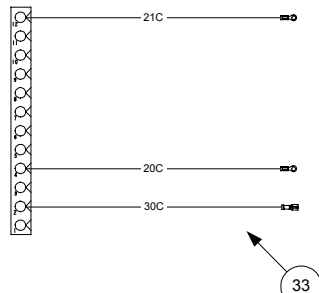
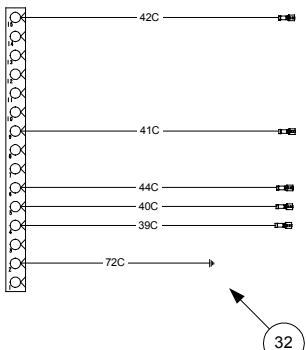
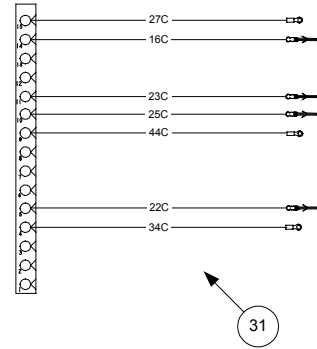
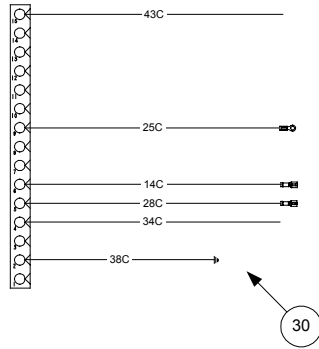
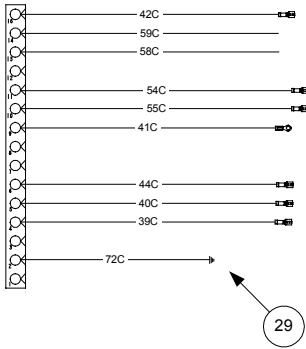
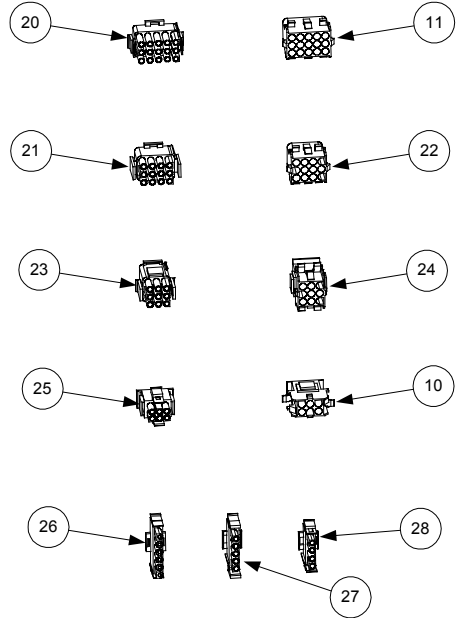
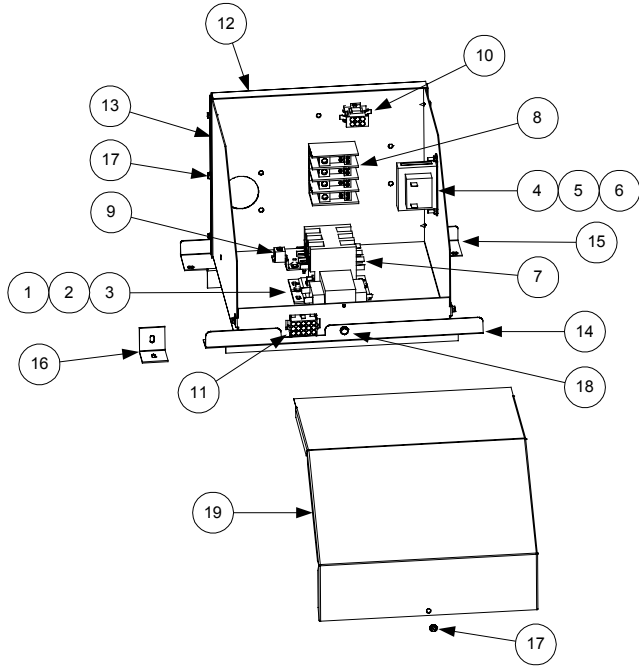

ITEM	PART #	COMPONENT
1	807-0680	Transformer, 208-240VAC/24VAC, 50/60Hz, 43VA
2	809-0112	Screw, 8-32 x 1¼-inch, Slotted Truss Head
3	809-0247	Nut, 8-32 Hex Keps
4	807-0979	Transformer, 208-240VAC/12VAC, 50/60Hz, 20VA (for Basket Lift)
5	809-0104	Screw, 8-32 x ½-inch Slotted Hex Washer Head
6	809-0050	Nut, 8-32 Hex
7	810-1202	Contactator, 3-pole, 600V, 40 Amp
8	807-2465	Power Block
9	807-0070	Terminal, Ground Lug
10	807-2136	Connector, 6-pin High Amp Female (2 x 3)
11	807-0875	Connector, 15-pin Female (3 x 5)
12	900-5000	Back, Contactor Box
13	900-5001	Contactator Box
14	900-5027	Brace, Contactor Box Front
15	900-5028	Brace, Contactor Box Rear
16	900-0289	Bracket, Contactor Box (used with Moisture Shield [Item 27, Page 22])
17	809-0360	Screw, 8-32 x ¾-inch Slotted Hex Washer Head Drill Point
18	809-0434	Screw, 8-32 x ¾-inch Hex Washer Head Machine
19	900-5150	Cover, Contactor Box
20	807-0804	Connector, 15-pin Male (3 x 5)
21	807-0160	Connector, 12-pin Male (3 x 4)
22	807-0159	Connector, 12-pin Female (3 x 4)
23	807-2137	Connector, 9-pin Male (3 x 3)
24	807-2138	Connector, 9-pin Female (3 x 3)
25	807-2135	Connector, 6-pin High Amp Male (2 x 3)
26	807-0184	Connector, 6-pin Male (1 x 6)
27	807-3075	Connector, 5-pin Male (1 x 5)
28	807-2078	Connector, 4-pin Male (1 x 4)
29	806-9299	Harness, Contactor Box Internal (15-pin female connector with 10 leads)
30	806-9095	Harness, Contactor Box External (15-pin male connector with 6 leads)
31	806-9309	Harness, EWBS Computer (15-pin male connector with 7 leads)
32	806-8808	Harness, Contactor Box Internal (15-pin female connector with 6 leads)
33	806-9308	Harness, EWBS IFB to Components (12-pin male connector with 3 leads)
34	106-0156	Harness, Element to Contactor (6-pin female connector with 6 leads)
*	806-8807	Harness, Element to Contactor (9-pin female connector with 6 leads)
35	806-9096	Harness, ESW Interface Board (6-pin male connector with 6 leads)
36	806-9305	Harness, EWBS Basket Lift (5-pin male connector with 4 leads)
37	806-9097	Harness, ESW/EWBS w/o Basket Lift (4-pin male connector with 4 leads)

* Not illustrated.

WATER SUPPLY COMPONENTS

TYPICAL WATER SUPPLY CONFIGURATIONS

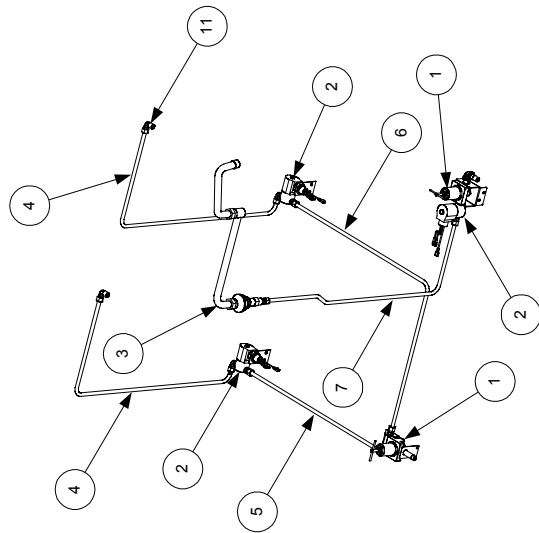
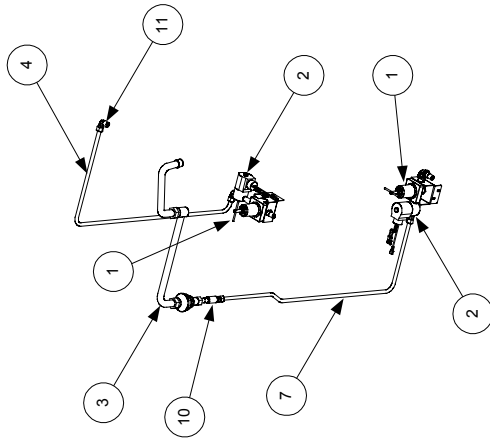
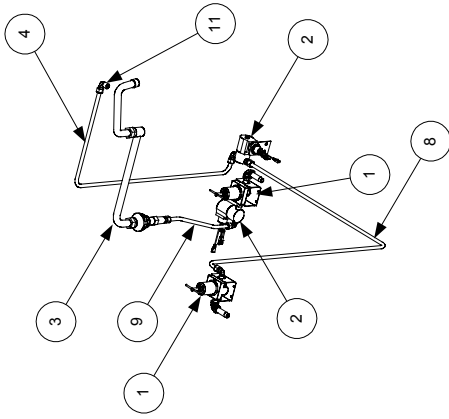

Single Unit with Basket Lifts

Single Unit without Basket Lifts

Double Unit without Basket Lifts

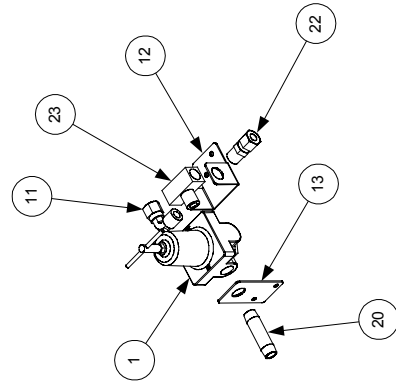
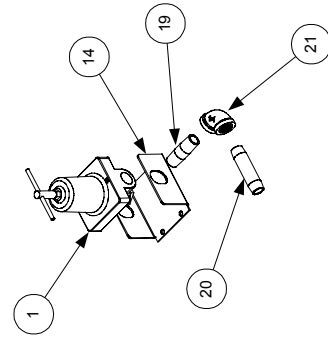
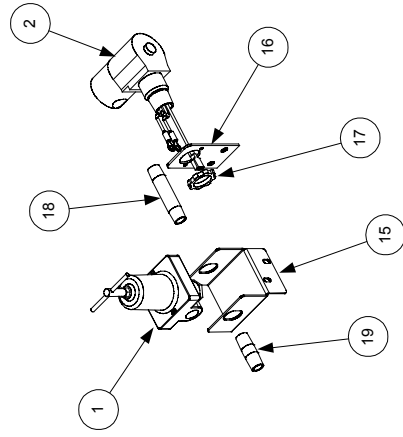

DETAIL OF PRESSURE REGULATOR AND SOLENOID COMPONENTS
(shown disproportionately large for clarity)

ITEM	PART #	COMPONENT
1	810-1208	Valve, Water Pressure Regulator
2	806-7551	Valve Assembly, Solenoid
3	813-0513	Faucet, Double Jointed (with no cutoff valve)
4	910-2513	Tubing, Solenoid Valve to Cookpot
5	812-1292	Tubing, Regulator Valve to Right Solenoid Valve (used in double units)
6	812-1293	Tubing, Regulator Valve to Left Solenoid Valve (used in double units)
7	910-5149	Tubing, Solenoid Valve to Faucet
8	910-8011	Tubing, Regulator Valve to Solenoid Valve (units with basket lifts only)
9	910-8012	Tubing, Solenoid Valve to Faucet (units with basket lifts only)
10	813-0507	Coupling, ¼-inch NPT Brass
11	810-0907	Compression Fitting, ⅜-inch NPT to Tubing 90° Elbow
12	900-2915	Bracket, Pressure Regulator Valve (used in double units)
13	900-2917	Brace, Water Inlet (used in double units)
14	900-7991	Bracket, Pressure Regulator Valve (units with basket lifts only)
15	900-2916	Bracket, Pressure Regulator Valve (units without basket lifts only)
16	900-1905	Bracket, Solenoid Valve (units without basket lifts only)
17	809-0454	Nut, ½-inch Conduit
18	813-0472	Nipple, ¼-inch NPT x 2.5-inch
19	813-0471	Nipple, ¼-inch NPT x 1.5-inch
20	813-0450	Nipple, ¼-inch NPT x 2.0-inch
21	813-0448	Elbow, 90° ¼-inch NPT
22	810-1025	Compression Fitting, ¼-inch NPT to Tubing Straight
23	813-0495	Tee, ¼-inch NPT Male Branch to ¼-inch NPT Female



Enodis[®]

One Company, Countless Solutions

Frymaster, L.L.C., 8700 Line Avenue, PO Box 51000, Shreveport, Louisiana 71135-1000
Shipping Address: 8700 Line Avenue, Shreveport, Louisiana 71106

TEL 1-318-865-1711 FAX (Parts) 1-318-219-7140 FAX (Tech Support) 1-318-219-7135

PRINTED IN THE UNITED STATES

SERVICE HOTLINE
1-800-551-8633

819-5680
May 2003