



Frymaster 1814E Series Electric Fryer Service & Parts Manual



Frymaster, a member of the Commercial Food Equipment Service Association, recommends using CFESA Certified Technicians.

24-Hour Service Hotline 1-800-551-8633

www.frymaster.com

E-mail: service@frymaster.com

SEPTEMBER 2011
* 8196911 *

NOTICE

IF, DURING THE WARRANTY PERIOD, THE CUSTOMER USES A PART FOR THIS MANITOWOC FOOD SERVICE EQUIPMENT OTHER THAN AN **UNMODIFIED** NEW OR RECYCLED PART PURCHASED DIRECTLY FROM FRYMASTER, OR ANY OF ITS AUTHORIZED SERVICE CENTERS, AND/OR THE PART BEING USED IS MODIFIED FROM ITS ORIGINAL CONFIGURATION, THIS WARRANTY WILL BE VOID. FURTHER, FRYMASTER AND ITS AFFILIATES WILL NOT BE LIABLE FOR ANY CLAIMS, DAMAGES OR EXPENSES INCURRED BY THE CUSTOMER WHICH ARISE DIRECTLY OR INDIRECTLY, IN WHOLE OR IN PART, DUE TO THE INSTALLATION OF ANY MODIFIED PART AND/OR PART RECEIVED FROM AN UNAUTHORIZED SERVICE CENTER.

⚠ DANGER

Copper wire suitable for at least 167°F (75°C) must be used for power connections.

⚠ DANGER

The electrical power supply for this appliance must be the same as indicated on the rating and serial number plate located on the inside of the fryer door.

⚠ DANGER

This appliance must be connected to the voltage and phase as specified on the rating and serial number plate located on the inside of the fryer door.

⚠ DANGER

All wiring connections for this appliance must be made in accordance with the wiring diagrams furnished with the equipment. Wiring diagrams are located on the inside of the fryer door.

⚠ DANGER

Do not store or use gasoline or other flammable vapors and liquids in the vicinity of this or any other appliance.

⚠ WARNING

Do not attach accessories to this fryer unless fryer is secured from tipping. Personal injury may result.

⚠ WARNING

Frymaster fryers equipped with legs are for permanent installations. Fryers fitted with legs must be lifted during movement to avoid damage and possible bodily injury. For a moveable or portable installation, Frymaster optional equipment casters must be used. Questions? Call 1-800-551-8633 or email at service@frymaster.com.

⚠ WARNING

Do not use water jets to clean this equipment.

⚠ WARNING

This equipment is intended for indoor use only. Do not install or operate this equipment in outdoor areas.

⚠ DANGER

Adequate means must be provided to limit the movement of this appliance without depending on or transmitting stress to the electrical conduit. A restraint kit is provided with the fryer. If the restraint kit is missing contact your local KES.

⚠ DANGER

Prior to movement, testing, maintenance and any repair on your Frymaster fryer, disconnect all electrical power from the fryer.

ELECTRICAL POWER SPECIFICATIONS

Three (3) Phase Requirements								
kW	VOLTAGE	PHASE	WIRE SERVICE	MINIMUM SIZE		AMPS PER LEG		
				AWG	mm ²	L1	L2	L3
14	208	3	3	6	16	39	39	39
14	240	3	3	6	16	34	34	34
14	480	3	3	8	10	17	17	17
14	220/380	3	4	6	16	21	21	21
14	240/415	3	4	6	16	20	20	21
14	230/400	3	4	6	16	21	21	21
17	208	3	3	6	16	48	48	48
17	240	3	3	6	16	41	41	41
17	480	3	3	6	16	21	21	21
17	220/380	3	4	6	16	26	26	26
17	240/415	3	4	6	16	24	24	24
17	230/400	3	4	6	16	25	25	25
22	208	3	3	4	25	61	61	61
22	240	3	3	4	25	53	53	53
22	480	3	3	6	16	27	27	27
22	220/380	3	4	6	16	34	34	34
22	240/415	3	4	6	16	31	31	31
22	230/400	3	4	6	16	32	32	32

Single Phase Requirements						
kW	VOLTAGE	PHASE	WIRE SERVICE	MINIMUM SIZE		AMPS
				AWG	mm ²	
14	208	1	2	3	34	68
14	240	1	2	4	25	59
14	480	1	2	8	10	30

FRYMASTER 1814E SERIES ELECTRIC FRYERS

TABLE OF CONTENTS

CAUTIONARY STATEMENTS.....	i
ELECTRICAL POWER SPECIFICATIONS.....	ii

CHAPTER 1: Service Procedures

1.1	General	1-1
1.2	Replacing a Controller.....	1-1
1.3	Replacing Component Box Components	1-1
1.4	Replacing a High-Limit Thermostat.....	1-3
1.5	Replacing a Temperature Probe	1-3
1.6	Replacing a Heating Element	1-5
1.7	Replacing Contactor Box Components	1-6
1.8	Replacing a Frypot	1-7
1.9	Built-In Filtration System Service Procedures.....	1-9
1.9.1	Filtration System Problem Resolution	1-9
1.9.2	Replacing the Filter Motor, Filter Pump and Related Components	1-10
1.9.3	Replacing the Filter Transformer or Filter Relay	1-11
1.10	Basket Lift Service Procedures	1-12
1.11	Interface Board Diagnostic Chart.....	1-15
1.12	Probe Resistance Chart.....	1-16
1.13	Wiring Diagrams	1-17
1.13.1	Basket Lift Wiring 208-250V.....	1-17
1.13.2	Basket Lift Wiring 100-120V.....	1-18
1.13.3	Standard 1814E Control Wiring.....	1-19
1.13.4	BK1814E Control Wiring	1-20
1.13.5	Component Box Wiring	1-21
1.13.6	Tilt Switch Wiring.....	1-22
1.13.7	Contactor Wiring – 17kW Full Vat DELTA SSR 208-250V	1-23
1.13.8	Contactor Wiring – 17kW Full Vat DELTA Mechanical 208-250V	1-24
1.13.9	Contactor Wiring – 17kW Full Vat DELTA Mechanical 480V	1-25
1.13.10	Contactor Wiring – 17kW Dual Vat DELTA SSR 208-250V	1-26
1.13.11	Contactor Wiring – 17kW Dual Vat DELTA Mechanical 208-250V/480V....	1-27
1.13.12	Contactor Wiring – 22kW Full Vat DELTA SSR 208-250V	1-28
1.13.13	Contactor Wiring – 22kW Full Vat DELTA Mechanical 208-250V	1-29
1.13.14	Contactor Wiring – 22kW Full Vat DELTA Mechanical 480V	1-30
1.13.15	Contactor Wiring – 17kW and 22kW Full Vat WYE SSR 208-250V	1-31
1.13.16	Contactor Wiring – 17kW and 22kW Full Vat WYE Mech 208-250V/480V .	1-32
1.13.17	Contactor Wiring – 17kW Dual Vat WYE SSR 208-250V	1-33
1.13.18	Contactor Wiring – 17kW Dual Vat WYE Mechanical 208-250V.....	1-34

CHAPTER 2: Parts List

2.1	Accessories.....	2-1
2.2	Basket Lift Assembly and Associated Parts.....	2-2
2.3	Doors, Sides, Tilt Housings, Top Caps and Casters.....	2-4
2.4	Drain System Components	2-5
2.4.1	Drain Tube Sections and Associated Parts.....	2-5
2.4.2	Drain Valves and Associated Parts (Units with Built-In Filtration)	2-7

FRYMASTER 1814E SERIES ELECTRIC FRYERS
TABLE OF CONTENTS cont.

2.4.3	Drain Valves and Associated Parts (Single Units without Built-In Filtration)	2-11
2.5	Electronics and Electrical Components.....	2-12
2.5.1	Component Boxes	2-12
2.5.2	Contactors Boxes	2-14
2.5.3	Heating Element Assemblies and Associated Parts	2-16
2.5.3.1	Element Assemblies and Hardware.....	2-16
2.5.3.2	Element Tube Assemblies	2-18
2.5.4	Controllers	2-19
2.5.5	Wiring.....	2-20
2.5.5.1	Contactors Box Wiring Assemblies 12-Pin Dual Vat.....	2-20
2.5.5.2	Contactors Box Wiring Assemblies 12-Pin Full Vat.....	2-20
2.5.5.3	Contactors Box Wiring Assemblies 6-Pin Left Element	2-21
2.5.5.4	Contactors Box Wiring Assemblies 9-Pin Right Element	2-21
2.5.5.5	Main Wiring Harnesses	2-22
2.5.5.6	Component Box, Filter Pump and Basket Lift Wiring Harnesses ...	2-23
2.5.5.7	Component Box to Filter Pump Harness.....	2-24
2.5.5.8	Basket Lift Harness	2-24
2.5.5.9	Interface Board to Controller Wiring Harnesses	2-24
2.5.5.10	Drain Harnesses (3000).....	2-24
2.6	Filtration System Components	2-25
2.6.1	Filter Pan Assembly	2-25
2.6.2	Filter Pump Motor Assembly	2-26
2.7	Frypots and Associated Components	2-27
2.8	Oil Return System Components	2-28
2.9	Wiring and Pin Connectors	2-30
2.10	Fasteners.....	2-31

1814E SERIES ELECTRIC FRYERS

CHAPTER 1: SERVICE PROCEDURES

1.1 General

Before performing any maintenance on your Frymaster fryer, disconnect the fryer from the electrical power supply.

When electrical wires are disconnected, it is recommended that they be marked in such a way as to facilitate re-assembly.

1.2 Replacing a Controller

1. Disconnect the fryer from the electrical power supply.
2. The controller bezel is held in place by screws at the bottom. Remove the screws and slide the bezel down.
3. Remove the two screws from the upper corners of the control panel. The control panel is hinged at the bottom and swings open from the top.
4. Unplug the wiring harness from the connector on the back of the controller and disconnect the grounding wire from terminal adjacent to the connector. Remove the control panel assembly by lifting it from the hinged slots in the control panel frame (If a fryer has a 3000 controller, mark and remove all wires/harnesses prior to removing controller).



5. Remove the controller from the control panel assembly and install the replacement controller. Reinstall the control panel assembly by reversing steps 1-4 (If installing a 3000 controller, ensure controller is configured and setup properly).

1.3 Replacing Component Box Components

1. Disconnect the fryer from the electrical power supply.
2. The controller bezel is held in place by screws at the bottom. Remove the screws and slide the bezel down.

3. Remove the two screws from the upper corners of the control panel and allow the control panel to swing down.
4. Unplug the wiring harness from the 15-pin connector on the interface board and disconnect the grounding wire from terminal adjacent to the 20-pin connector on the back of the controller. Remove the control panel assembly by lifting it from the hinge slots in the control panel frame.
5. Disconnect the wiring from the component to be replaced, being sure to make a note of where each wire was connected.
6. Dismount the component to be replaced and install the new component, being sure that any required spacers, insulation, washers, etc. are in place.

NOTE: If more room to work is required, the control panel frame assembly may be removed by removing the hex head screws that secure it to the fryer cabinet (see illustration below). If this option is chosen, all control panel assemblies must be removed per steps 1 and 2 above. The cover plate on the lower front of the component box may also be removed if desired. *Removing the component box itself from the fryer is not recommended due to the difficulty involved in disconnecting and reconnecting the oil-return valve rods, which pass through openings in the component box.*

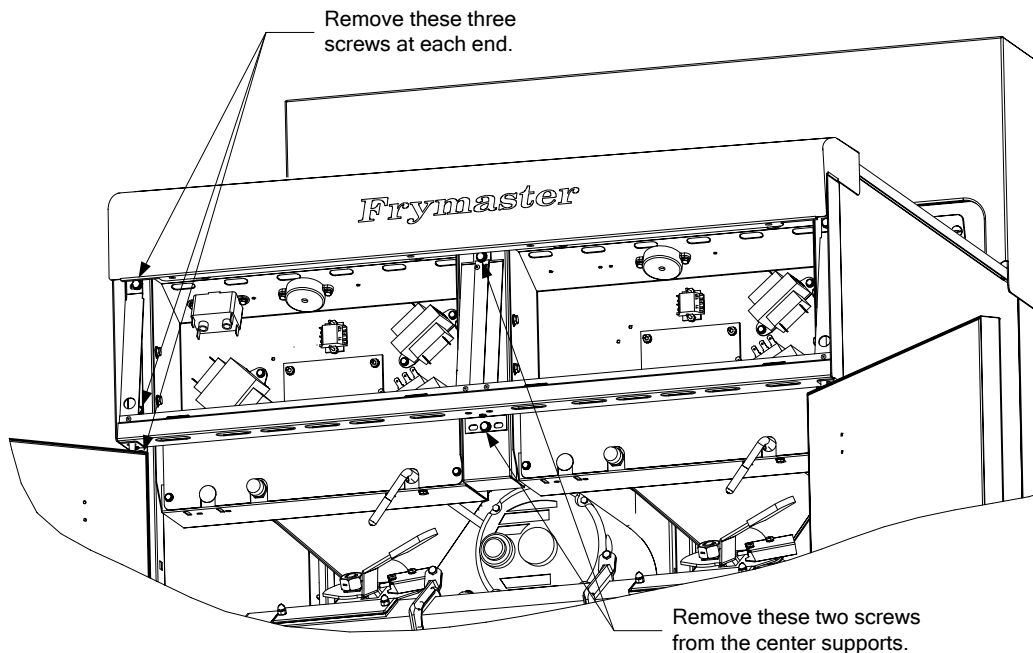

Removing the Control Panel Frame and Top Cap Assembly

7. Reconnect the wiring disconnected in Step 3, referring to your notes and the wiring diagrams on the fryer door to ensure that the connections are properly made. Also, verify that no other wiring was disconnected accidentally during the replacement process.
8. Reverse steps 1 through 4 to complete the replacement and return the fryer to service.

1.4 Replacing a High-Limit Thermostat

1. Remove the filter pan and lid from the unit. Drain the frypots into a Shortening Disposal Unit (SDU) or other appropriate metal container.



DO NOT drain more than one full frypot or two split frypots into the SDU at one time.

2. Disconnect the fryer from the electrical power supply and reposition it to gain access to the rear of the fryer.
3. Remove the four screws from both the left and right sides of the lower back panel.
4. Locate the high-limit that is being replaced and follow the two-black wires to the 12-pin connector C-6. Note where the leads are connected prior to removing them from the connector. Unplug the 12-pin connector C-6 and using a pin-pusher push the pins of the high-limit out of the connector.
5. Using a wrench, carefully unscrew the high-limit thermostat to be replaced.
6. Apply Loctite™ PST 567 or equivalent sealant to the threads of the replacement and screw it securely into the frypot.
7. Insert the leads into the 12-pin connector C-6 (see illustration below). For full-vat units or the left half of a dual-vat unit (as viewed from the rear of the fryer) the leads go into positions 1 and 2 of the connector. For the right half of a dual-vat unit (as viewed from the rear of the fryer), the leads go into positions 7 and 8. In either case, polarity does not matter.

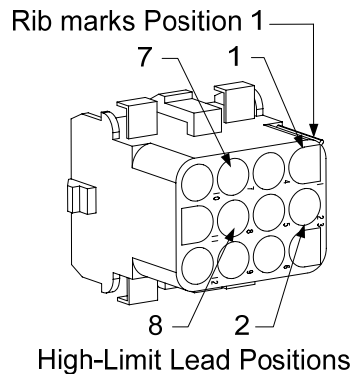

8. Reconnect the 12-pin connecting plug C-6. Use wire ties to secure any loose wires.
9. Reinstall the back panels reposition the fryer under the exhaust hood, and reconnect it to the electrical power supply to return the fryer to service.

1.5 Replacing a Temperature Probe

1. Remove the filter pan and lid from the unit. Drain the frypots into a Shortening Disposal Unit (SDU) or other appropriate metal container.



DO NOT drain more than one full frypot or two split frypots into the SDU at one time.

2. Disconnect the fryer from the electrical power supply and reposition it to gain access to the rear of the fryer.
3. Remove the four screws from both sides of the lower back panel. Then remove the two screws on both the left and right sides of the back of the tilt housing. Lift the tilt housing straight up to remove from the fryer.
4. Locate the red and white wires of the temperature probe to be replaced. Note where the leads are connected prior to removing them from the connector. Unplug the 12-pin connector C-6 and using a pin-pusher push the pins of the temperature probe out of the connector.
5. Raise the element and remove the securing probe bracket and metal tie wraps that secure the probe to the element (see illustration below).

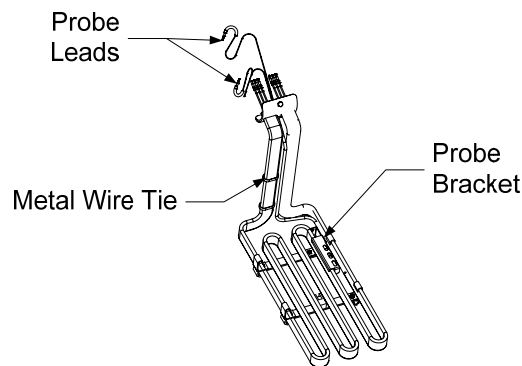

6. Gently pull on the temperature probe and grommet, pulling the wires up the rear of the fryer and through the element tube assembly.
7. Insert the replacement temperature probe (wires first) into the tube assembly ensuring that the grommet is in place. Secure the probe to the elements using the bracket which was removed in Step 5 and the metal tie wraps which were included in the replacement kit.
8. Route the probe wires out of the tube assembly following the element wires down the back of the fryer through the Heyco bushings to the 12-pin connector C-6. Secure the wires to the sheathing with wire ties.
9. Insert the temperature probe leads into the 12-pin connector C-6 (see illustration below). For full-vat units or the right half of a dual-vat unit (as viewed from the rear of the fryer) the yellow lead goes into position 3 and the white lead into position 4 of the connector. For the left half of a dual-vat unit (as viewed from the rear of the fryer), the yellow lead goes into position 9 and the white lead into position 10. **NOTE: *Right* and *left* refer to the fryer as viewed from the rear.**

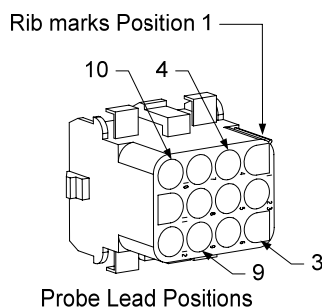

10. Secure any loose wires with wire ties making sure that the lead wires will not interfere with the movement of the springs. Rotate the elements up and down making sure that movement is not restricted and that the wires are not pinched.
11. Reinstall the tilt housing and back panels, reposition the fryer under the exhaust hood, and reconnect it to the electrical power supply to return the fryer to service.

1.6 Replacing a Heating Element

1. Perform steps 1-3 of section 1.5, *Replacing a Temperature Probe*.
2. On dual-vat fryers, and on full-vat fryers where the temperature probe is attached to the element being replaced, disconnect the wire harness containing the probe wiring. Using a pin pusher, disconnect the probe wires from the 12-pin connector C-6.
3. In the rear of the fryer directly behind the frypot disconnect the 6-pin connector for the left element (as viewed from the front of the fryer) or the 9-pin connector for the right element. Press in on the tabs on each side of the connector while pulling outward on the free end to extend the connector and release the element leads (see photo below). Pull the leads out of the connector and out of the wire sleeving.

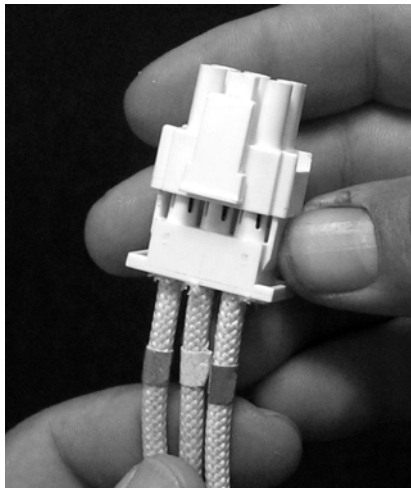

4. Raise the element to the full up position and support the elements.
5. Remove the hex head screws and nuts that secure the element to the tube assembly and pull the element out of the frypot. **NOTE:** Full-vat elements consist of two dual-vat elements clamped together. For full-vat units, remove the element clamps before removing the nuts and screws that secure the element to the tube assembly.
6. If applicable, recover the probe bracket and probe from the element being replaced and install them on the replacement element. Install the replacement element in the frypot, securing it with the nuts and screws removed in Step 5 to the tube assembly. Ensure the gasket is between the tube and element assembly.
7. Route the element leads through the element tube assembly and into the wire sleeving to prevent chafing. Ensure that the wire sleeving is routed back through the Heyco bushing keeping it clear

from the lift springs. Also ensure that the wire sleeving extends into the tube assembly to prevent the edge of the tube assembly from chafing the wires. Press the pins into the connector in accordance with the diagram on the following page, and then close the connector to lock the leads in place. **NOTE:** It is critical that the wires be routed through the sleeving to prevent chafing.

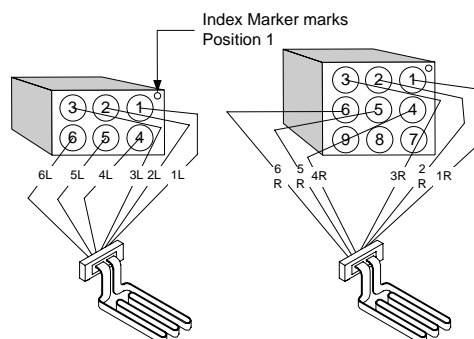

8. Reconnect the element connector ensuring that the latches lock.
9. Insert the temperature probe leads into the 12-pin wiring harness connector C-6 (see illustration below). For full-vat units or the right half of a dual-vat unit, the red lead goes into position 3 and the white into position 4. For the left half of a dual-vat unit, the red lead goes into position 9 and the white into position 10. **NOTE:** *Right* and *left* refer to the fryer as viewed from the rear.

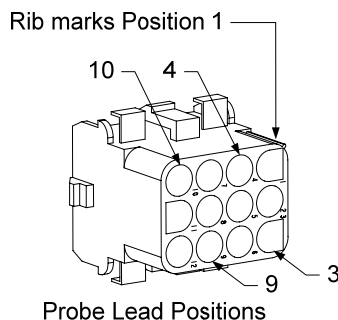

10. Reconnect the 12-pin connector C-6 of the wiring harness disconnected in Step 2.
11. Lower the element down onto the basket rack.
12. Reinstall the tilt housing and back panels, reposition the fryer under the exhaust hood, and reconnect it to the electrical power supply.

1.7 Replacing Contactor Box Components

1. If replacing a contactor box component above the built-in filter system, remove the filter pan and lid from the unit. Drain the frypots into a Shortening Disposal Unit (SDU) or other appropriate metal container. If replacing a contactor box component in a non-filter unit or a frypot that's not over the filter pan, drain the frypot above the box into a Shortening Disposal Unit (SDU) or other appropriate metal container.



DANGER

DO NOT drain more than one full frypot or two split frypots into the SDU at one time.

2. Disconnect the fryer from the electrical power supply.
3. Remove the two screws securing the cover of the contactor box. The contactor boxes above the filter pan are accessed by sliding under the fryer. They are located to the left and right above the guide rails (see photo below). The contactor boxes of non-filter units or frypots not over the filter pan are accessed by opening the fryer door directly under the affected frypot.

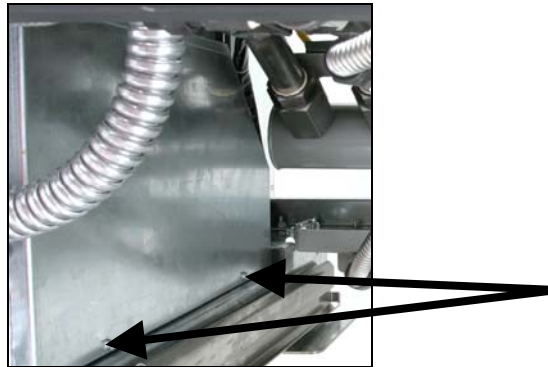

Remove two screws to access contactor box components above the filter pan.

4. The contactors and relays are held on by threaded pin studs so that only removal of the nut is required to replace the component.
5. After performing necessary service, reverse steps 1-4 to return the fryer to operation.

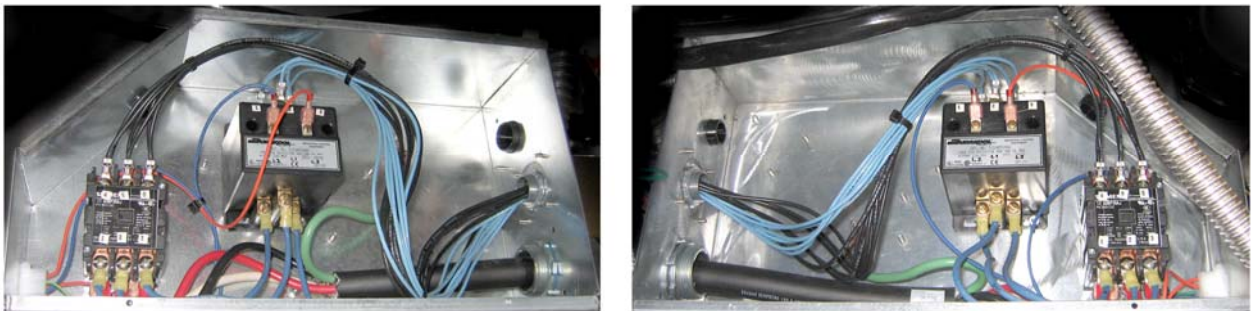

Left and right views of mechanical contactor box components.

1.8 Replacing a Frypot

1. Drain the frypot into the filter pan or, if replacing a frypot over the filter system, into a Shortening Disposal Unit (SDU) or other appropriate metal container. If replacing a frypot over the filter system, remove the filter pan and lid from the unit.

⚠ DANGER

DO NOT drain more than one full frypot or two split frypots into the SDU at one time.

2. Disconnect the fryer from the electrical power supply and reposition it to gain access to both the front and rear.
3. Remove the screws from the bottom of the bezel. Lower and remove the bezel.

4. Remove the two screws from the upper corners of the control panels and allow them to swing down.
5. Unplug all harnesses and ground wires from the backs of the controllers. Remove the controllers by lifting them from the hinge slots in the control panel frame.
6. Remove the tilt housing and back panels from the fryer. The tilt housing must be removed first in order to remove the upper back panel.
7. To remove the tilt housing remove the hex head screws from the rear edge of the housing. The housing can be lifted straight up and off the fryer.
8. Remove the control panel by removing the screw in the center and the nuts on both sides.
9. Loosen the component boxes by removing the screws, which secure them in the cabinet.
10. Dismount the top cap by removing the nuts at each end that secure it to the cabinetry.
11. Remove the hex head screw that secures the front of the frypot to the cabinet cross brace.
12. Remove the top-connecting strip that covers the joint with the adjacent frypot.
13. Unscrew the Teflon vent/vacuum-breaker tube fitting, unscrew the nut located on the front of each section of drain tube, and remove the tube assembly from the fryer.
14. Remove the covers from the drain safety switch(es) and disconnect the switch wiring at the switch(es).
15. At the rear of the fryer, unplug the 12-pin connector C-6 and, using a pin pusher, disconnect the high-limit thermostat leads.
16. Disconnect the oil return flexline(s) at the frypot end(s).
17. Raise the elements to the “up” position and disconnect the element springs.
18. Remove the machine screws and nuts that secure the element tube assembly to the frypot. Carefully lift the element assembly from the frypot and secure it to the cross brace on the rear of the fryer with wire ties or tape.
19. Carefully lift the frypot from the fryer and place it upside down on a stable work surface.
20. Recover the drain valve(s), oil return flexline connection fitting(s), and high-limit thermostat(s) from the frypot. Clean threads and apply Loctite™ PST 567 or equivalent sealant to the threads of the recovered parts and install them in the replacement frypot.
21. Carefully lower the replacement frypot into the fryer. Reinstall the hex head screw removed in step 7 to attach the frypot to the fryer.
22. Position the element tube assembly in the frypot and reinstall the machine screws and nuts removed in step 14.

23. Reconnect the oil return flexlines to the frypot, and replace aluminum tape, if necessary, to secure heater strips to the flexlines.
24. Insert the high-limit thermostat leads disconnected in step 13 (see illustration on page 1-3 for pin positions).
25. Reconnect the drain safety switch wiring to the switch(es) in accordance with the diagram below then reinstall the switch covers.

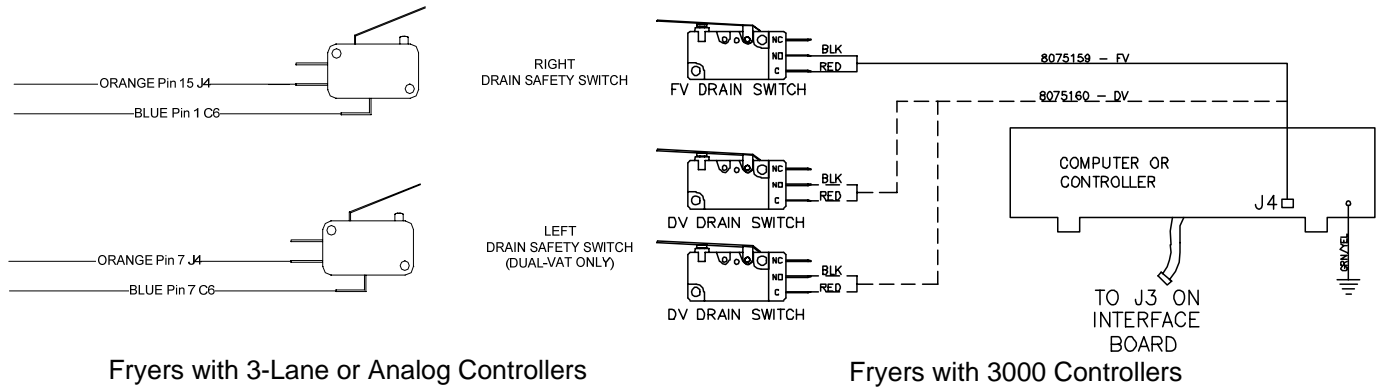

26. Reinstall the drain tube assembly.
27. Reinstall the top connecting strips, top cap, control panel, component box, tilt housing and back panels.
28. Reinstall controllers in the control panel frame and reconnect the wiring harnesses and ground wires.
29. Reposition the fryer under the exhaust hood and reconnect it to the electrical power supply.

1.9 Built-in Filtration System Service Procedures

1.9.1 Filtration System Problem Resolution

One of the most common causes of filtration problems is placing the filter paper on the bottom of the filter pan rather than over the filter screen.

⚠ CAUTION

Ensure that filter screen is in place prior to filter paper placement and filter pump operation. Improper screen placement is the primary cause of filtration system malfunction.

Whenever the complaint is “the pump is running, but no oil is being filtered,” check the installation of the filter paper, and ensure that the correct size is being used. While you are checking the filter paper, verify that the O-rings on the pick-up tube of the filter pan are in good condition. Missing or worn O-rings allow the pump to take in air and decrease its efficiency.

If the pump motor overheats, the thermal overload will trip and the motor will not start until it is reset. If the pump motor does not start, press the red reset switch (button) located on the rear of the motor at the front of the fryer.

If the pump starts after resetting the thermal overload switch, then something is causing the motor to overheat. A major cause of overheating is when several frypots are filtered sequentially, overheating

the pump and motor. Allow the pump motor to cool at least 30 minutes before resuming operation. Pump overheating can be caused by:

- Solidified shortening in the pan or filter lines, or
- Attempting to filter unheated oil (cold oil is more viscous, overloading the pump motor and causing it to overheat).

If the motor runs but the pump does not return oil, there is a blockage in the pump. Incorrectly sized or installed paper/pads will allow food particles and sediment to pass through the filter pan and into the pump. When sediment enters the pump, the gears bind, causing the motor to overload, again tripping the thermal overload. Shortening that has solidified in the pump will also cause it to seize, with the same result.

A pump seized by debris or hard shortening can usually be freed by manually moving the gears with a screwdriver or other instrument.

Disconnect power to the filter system, remove the input plumbing from the pump, and use a screwdriver to manually turn the gears.

- Turning the pump gears in reverse will release a hard particle.
- Turning the pump gears forward will push softer objects and solid shortening through the pump and allow free movement of the gears.

Incorrectly sized or installed paper/pads will also allow food particles and sediment to pass through and clog the suction tube on the bottom of the filter pan. Particles large enough to block the suction tube may indicate that the crumb tray is not being used. Pan blockage can also occur if shortening is left in the pan and allowed to solidify. Blockage removal can be accomplished by forcing the item out with an auger or drain snake. Compressed air or other pressurized gases should not be used to force out the blockage.

1.9.2 Replacing the Filter Motor, Filter Pump, and Related Components

1. Remove the filter pan and lid from the unit. Drain the frypots into a Shortening Disposal Unit (SDU) or other appropriate metal container.

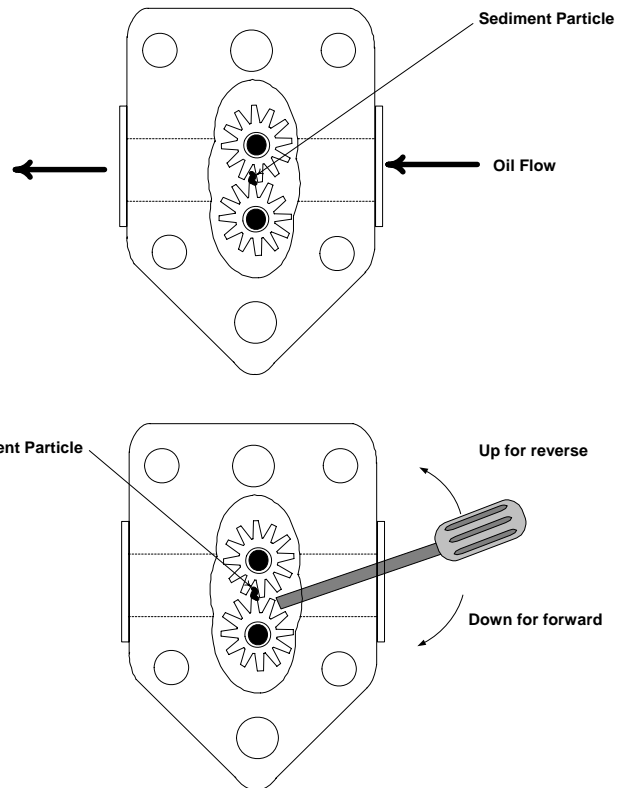

⚠ DANGER
DO NOT drain more than one full frypot or two split frypots into the SDU at one time.

2. Disconnect the fryer from the electrical power supply and reposition it to gain access to both the front and rear.
3. Disconnect the two flexlines running to the oil-return manifold at the rear of the fryer as well as the pump suction flexline at the end of the filter pan connection.
4. Loosen the four nuts and bolts that secure the filter motor bridge.
5. Remove the cover plate from the front of the motor and disconnect the motor wires.
6. Unplug the pump motor assembly 6-pin connector C-2 and, using a pin pusher, disconnect the vent vacuum-breaker solenoid (pins 2 and 5) that is attached to the oil return manifold.
7. Carefully lower the bridge with the motor and pump assembly to the floor.
8. Once on the floor, pull the assembly out the front of the fryer.
9. When required service has been completed, reverse steps 4-12 to reinstall the bridge. **NOTE:** The black motor wires go on the top terminal, the white on the bottom. The pump solenoid valve wires go in positions 1 and 4 of the 6-pin connector C-2; the vent vacuum-breaker solenoid valve wires go in positions 2 and 5; the white heater tape wire goes into position 3 and the black wire goes into position 6 (see illustration on the following page).

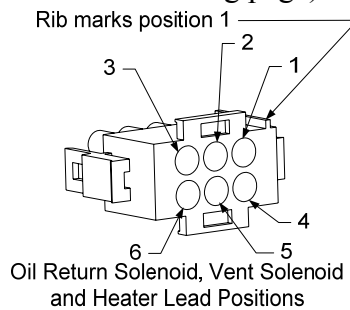

10. Reconnect the unit to the electrical power supply, and verify that the pump is functioning correctly (i.e., when a filter handle is placed in the ON position, the motor should start and there should be strong suction at the intake fitting and outflow at the rear flush port.)
11. When proper operation has been verified, reinstall the back panels and the filter pan and lid.
12. Reposition the fryer under the exhaust hood and reconnect it to the electrical power supply to return the fryer to service.

1.9.3 Replacing the Filter Transformer or Filter Relay

Disconnect the fryer from the electrical power supply. Remove the left controller from the fryer to expose the interior of the left component box. The filter transformer and relay are located as shown in the illustration on the following page. **NOTE:** The right component box is identical to the left except that the filter transformer and relay are not present. The components are held on by threaded pin studs so that only removal of the nut is required to replace the component.

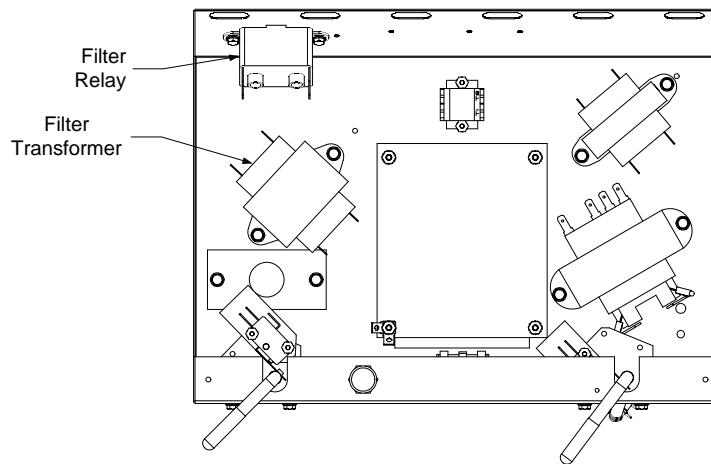

Dual-vat configuration illustrated. In full-vat units, left filter handle is not present.

1.10 Basket Lift Service Procedures

1814E Series electric fryers may be equipped with automatic basket lifts. Basket lifts always come in pairs, although each operates independently.

A **modular basket lift** (illustrated on the following page) is a self-contained sub-assembly consisting of a pair of toothed rods which support removable basket lift arms, a pair of reversible-drive gear motors, and four microswitches. The gear motors engage the teeth of the rods, moving them up or down depending upon the motors' direction of rotation. The microswitches at the upper and lower limits of movement stop the motors when the basket is in the full up or full down position. Timing circuitry in the controller initiates and stops basket lift operation depending upon the variables programmed by the operator. When the product button is pressed, the timing circuitry activates a coil in the basket lift relay to supply power to the lower microswitch. The microswitches stop the motor at the lift's upper and lower travel limits and reverse the direction of current flow thus reversing the motor direction.

When the product button is pushed on the computer/controller, current flows through a coil in the basket lift relay, causing the lower circuit to be activated. The basket lift lowers, closing the normally open upper-micro-switch. When the downward-moving rod opens the lower normally closed microswitch, the power to the motor ceases to flow. When the computer/controller times out, the current to the relay coil is cut, allowing the upper circuit to be activated. The basket lift then raises and re-closes the lower microswitch. When the basket lift rod clears the upper microswitch, the microswitch reopens, power to the circuit is cut, and the motor stops. Pushing the product button restarts the cycle.

Problems with the basket lift can be grouped into three categories:

- Binding/jamming problems
- Motor and gear problems
- Electronic problems

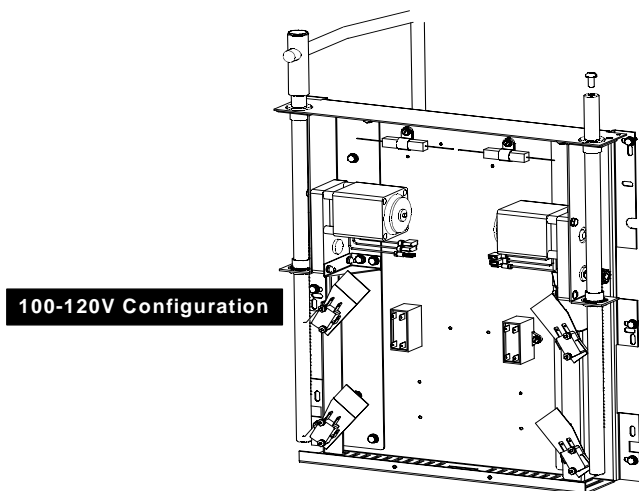

100-120V Configuration

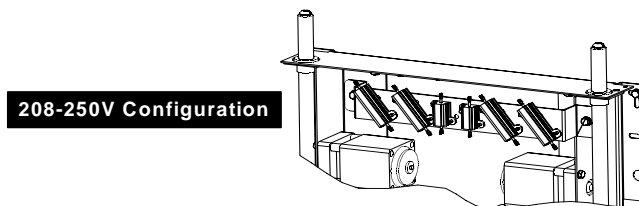

208-250V Configuration

BINDING/JAMMING PROBLEMS

Noisy, jerky or erratic movement of the lifts is usually due to lack of lubrication of the rods and their bushings. Apply a light coat of Lubriplate[®] or similar lightweight white grease to the rod and bushings to correct the problem.

With the modular basket lift, another possible cause of binding is improper positioning of the motor, which prevents the gear from correctly engaging the teeth in the rod. To correct the problem, loosen the screws that hold the motor in place and move it forward or backward until the rod has just enough slack to be rotated slightly.

MOTOR AND GEAR PROBLEMS

With the modular basket lift, the most likely problem to be encountered in this category is erratic motion of the lift due to a worn drive gear. Failure to keep the lift rod and bushings properly lubricated will cause unnecessary wear of the gear. The problem is corrected by replacing the worn gear.

If the lift cycles correctly but fails to remain in the up position (i.e., goes up, but then slowly settles back down into the frypot), the problem is a failed motor brake. A failed motor brake cannot be repaired and requires replacement of the motor itself.

If power is reaching the motor but the motor fails to run, the motor is burned out and must be replaced.

ELECTRONIC PROBLEMS

Within this category are problems associated with the relays, microswitches, capacitors, resistors, interface board, wiring, and controls. The most common problem in this category is a lift that continuously travels up and down. This is usually caused by a microswitch that is out of adjustment. Troubleshooting the electronics of a modular basket lift is simply a process of verifying current flow through the individual components up to and including the motor. Using a multimeter set to the 250

VAC range, check the connections on both sides of the component for the presence of the applied line voltage. The schematic below and the wiring diagram on page 1-17 can identify the components and wiring connection points.

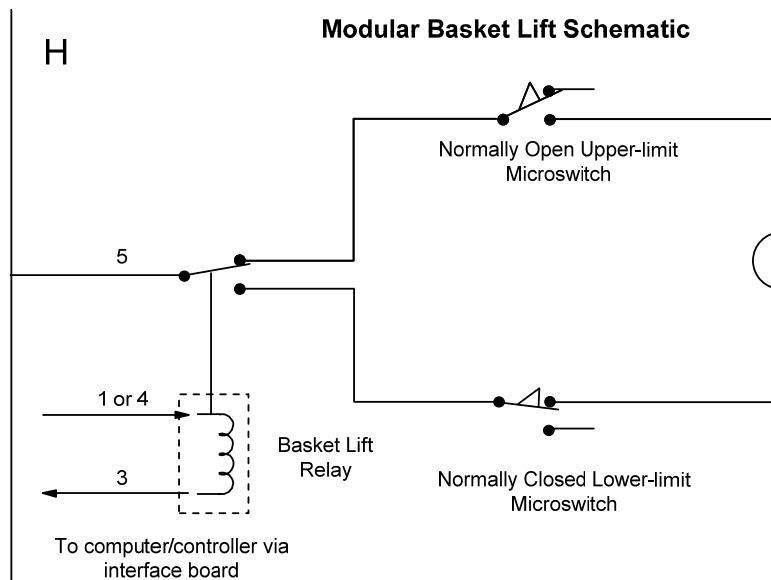

1.11 Interface Board Diagnostic Chart

The following diagram and charts provide ten quick system checks that can be performed using only a multimeter.

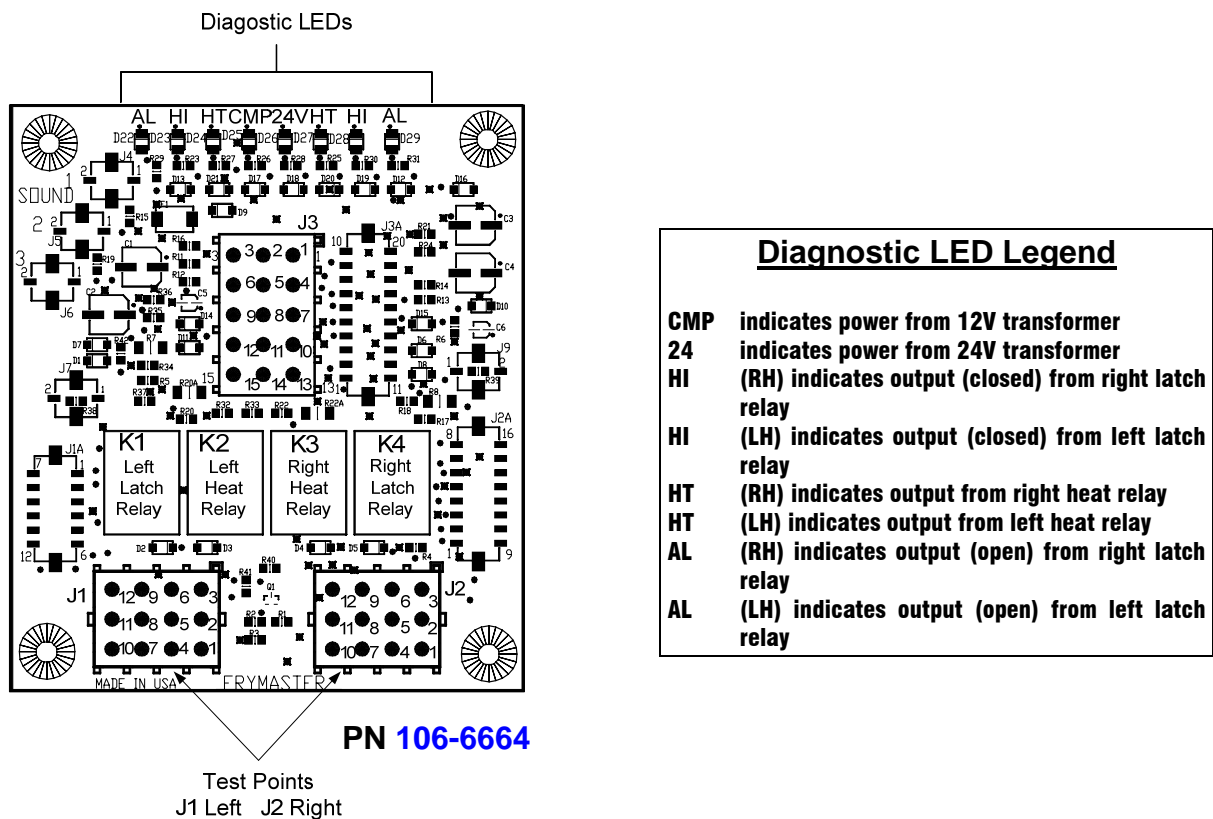

NOTE – When testing the test points on J1 and J2 pin 1 is located in the bottom right corner of both J1 and J2. These test points are ONLY for boards with J1 and J2 plugs on the front of the board.

Meter Setting	Test	Pin	Pin	Results
12 VAC Power	50 VAC Scale	3 of J2	1 of J2	12-16 VAC
24 VAC Power	50 VAC Scale	2 of J2	Chassis	24-30 VAC
*Probe Resistance (RH)	R X 1000 OHMS	11 of J2	10 of J2	See Chart
*Probe Resistance (LH)	R X 1000 OHMS	1 of J1	2 of J1	See Chart
High-Limit Continuity (RH)	R X 1 OHMS	9 of J2	6 of J2	0 - OHMS
High-Limit Continuity (LH)	R X 1 OHMS	6 of J1	9 of J1	0 - OHMS
Latch Contactor Coil (RH)	R X 1 OHMS	8 of J2	Chassis	3-10 OHMS
Latch Contactor Coil (LH)	R X 1 OHMS	5 of J1	Chassis	3-10 OHMS
Heat Contactor Coil (RH)	R X 1 OHMS	7 of J2	Chassis	11-15 OHMS
Heat Contactor Coil (LH)	R X 1 OHMS	4 of J1	Chassis	11-15 OHMS

*** Disconnect 20-Pin harness from the controller before testing the probe circuit.**

1.12 Probe Resistance Chart

<h3 style="text-align: center;">Probe Resistance Chart</h3> <p style="text-align: center;"><i>For use with fryers manufactured with Minco Thermistor probes only.</i></p>																	
F	OHMS	C	F	OHMS	C	F	OHMS	C	F	OHMS	C	F	OHMS	C			
60	1059	16	130	1204	54	200	1350	93	270	1493	132	340	1634	171			
65	1070	18	135	1216	57	205	1361	96	275	1503	135	345	1644	174			
70	1080	21	140	1226	60	210	1371	99	280	1514	138	350	1654	177			
75	1091	24	145	1237	63	215	1381	102	285	1524	141	355	1664	179			
80	1101	27	150	1247	66	220	1391	104	290	1534	143	360	1674	182			
85	1112	29	155	1258	68	225	1402	107	295	1544	146	365	1684	185			
90	1122	32	160	1268	71	230	1412	110	300	1554	149	370	1694	188			
95	1133	35	165	1278	74	235	1422	113	305	1564	152	375	1704	191			
100	1143	38	170	1289	77	240	1432	116	310	1574	154	380	1714	193			
105	1154	41	175	1299	79	245	1442	118	315	1584	157	385	1724	196			
110	1164	43	180	1309	82	250	1453	121	320	1594	160	390	1734	199			
115	1174	46	185	1320	85	255	1463	124	325	1604	163	395	1744	202			
120	1185	49	190	1330	88	260	1473	127	330	1614	166	400	1754	204			
125	1195	52	195	1340	91	265	1483	129	335	1624	168	405	1764	207			

1.13 Wiring Diagrams

1.13.1 Modular Basket Lift Wiring Diagram 208-250V

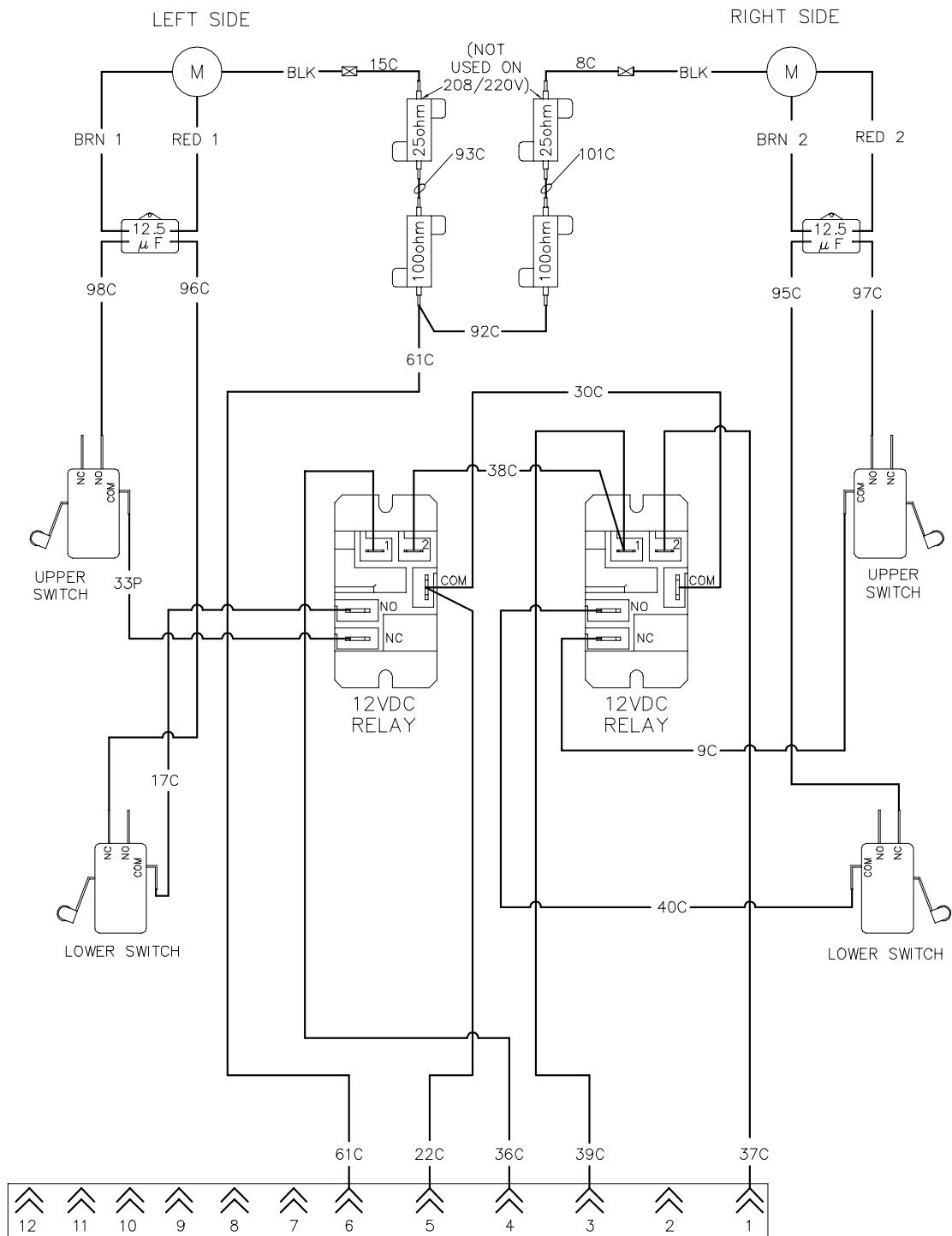

REFERENCES TO LEFT & RIGHT ARE
FROM THE REAR OF THE FRYER

8050888D

1.13.2 Modular Basket Lift Wiring Diagram 100-120V

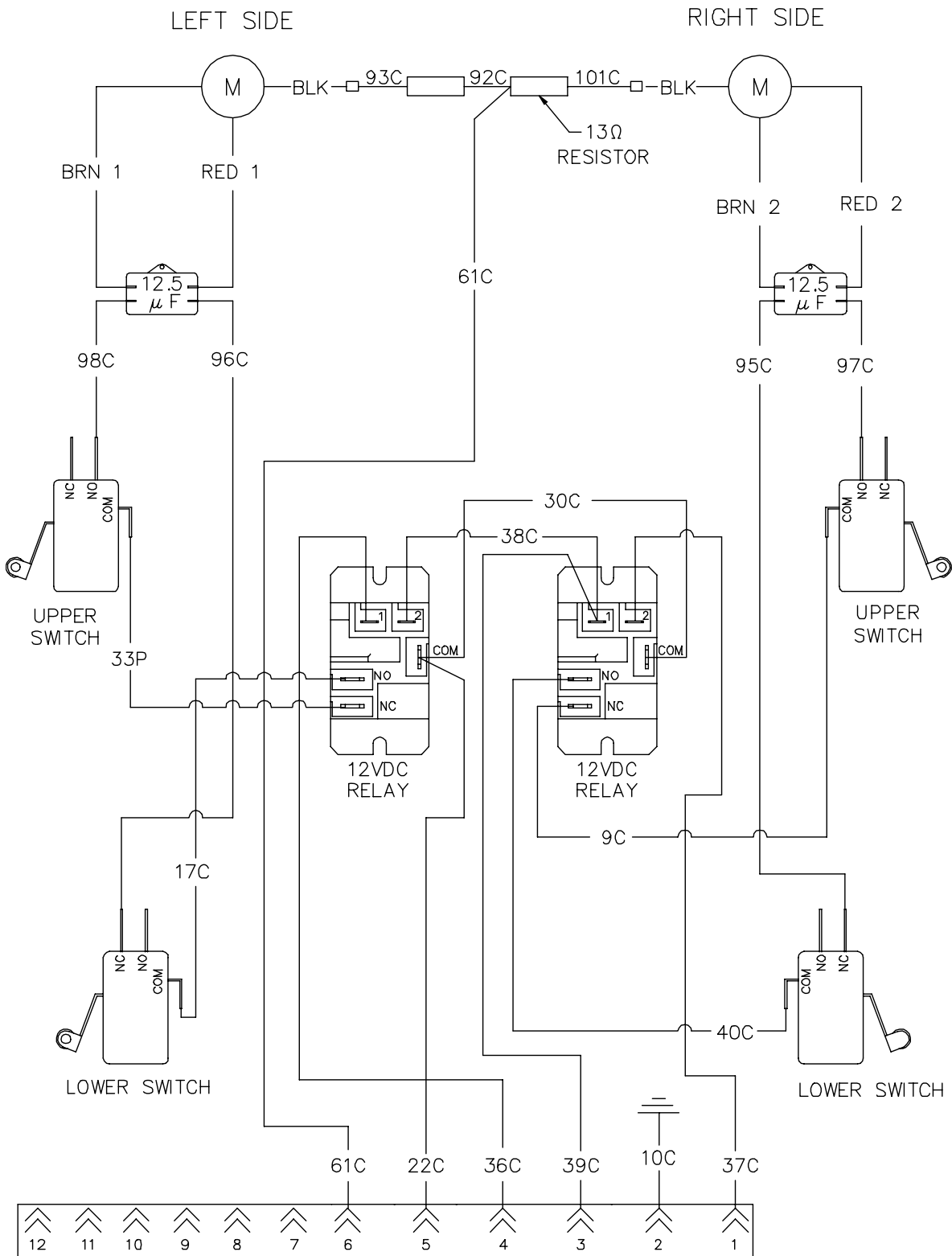

REFERENCES TO LEFT & RIGHT ARE FROM THE REAR OF THE FRYER

8050555E

1.13.3 Standard 1814E Control Wiring with 3000 Controls

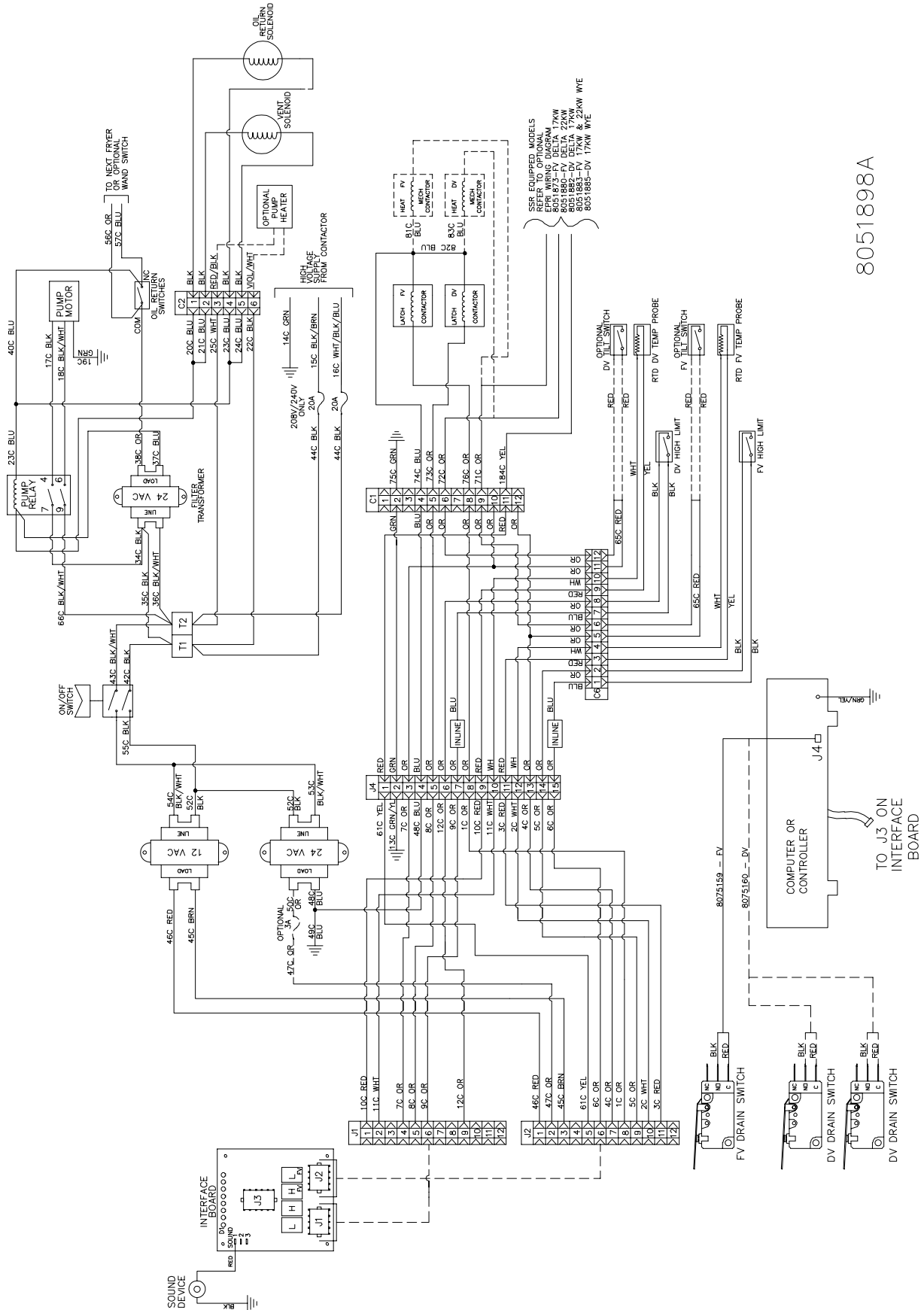

8051898A

1.13.4 BK1814E Control Wiring

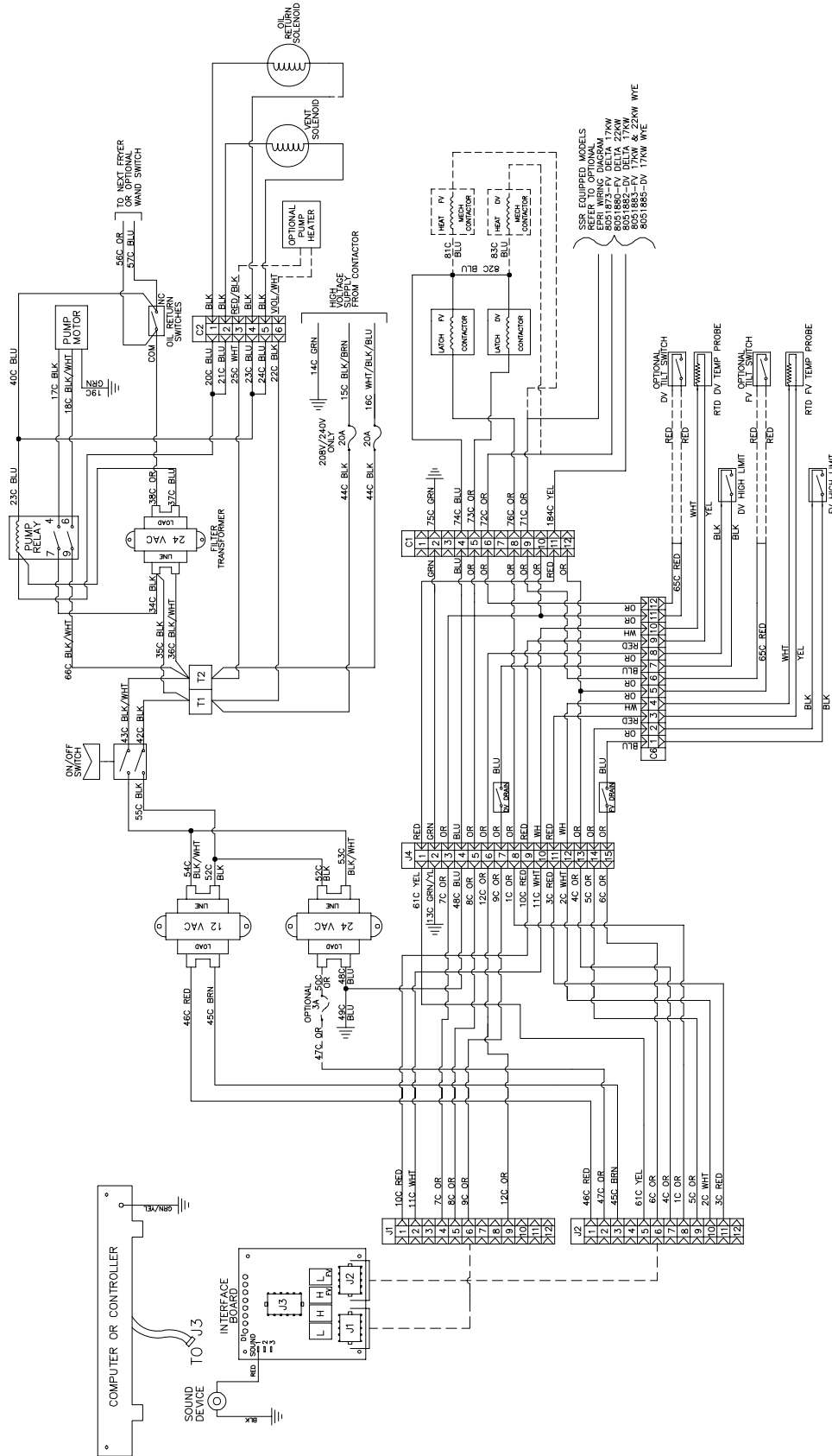

8051872B

1.13.5 Component Box Wiring

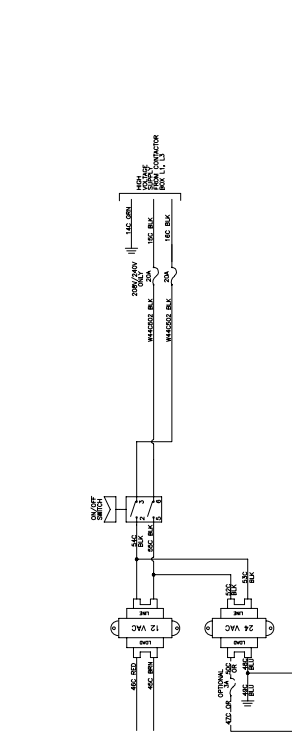

DOMESTIC 208/240V COMPONENT BOX W/O FILTER, W/POWER SWITCH, (2) 20A FUSES, OPTIONAL 3A FUSE

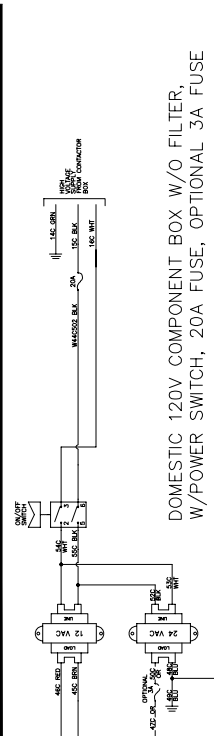

DOMESTIC 120V COMPONENT BOX W/O FILTER, W/POWER SWITCH, 20A FUSE, OPTIONAL 3A FUSE

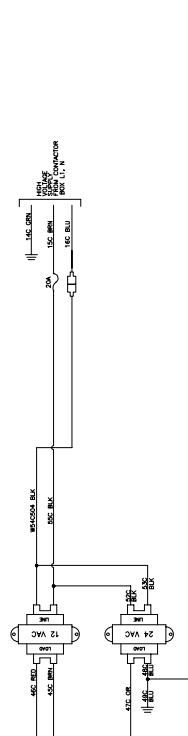

CE COMPONENT BOX W/O FILTER, 20A FUSE

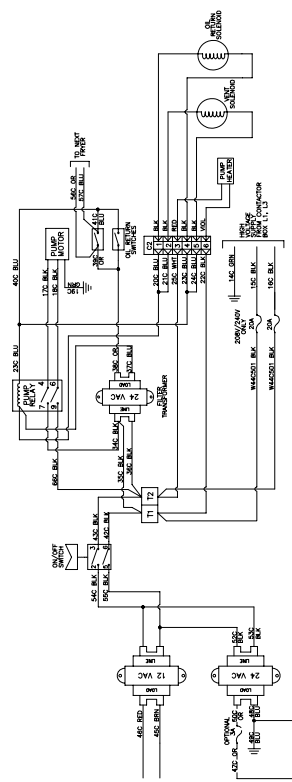

DOMESTIC 208/240V COMPONENT BOX W/FILTER, W/POWER SWITCH, (2) 20A FUSES, OPTIONAL 3A FUSE

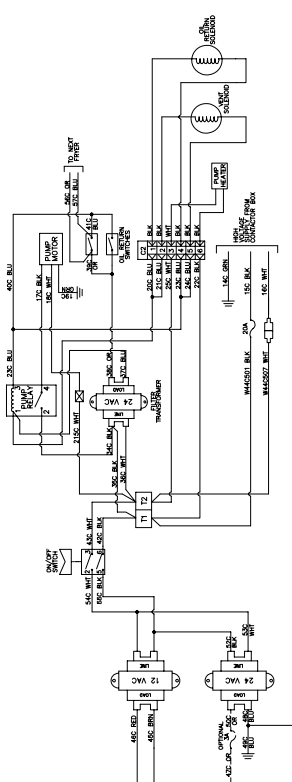

DOMESTIC 120V COMPONENT BOX W/FILTER, W/POWER SWITCH, 20A FUSE, OPTIONAL 3A FUSE

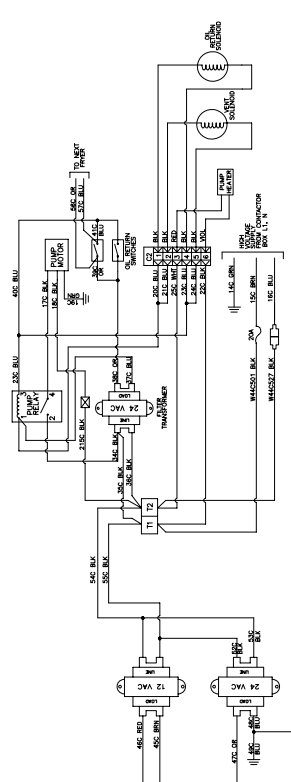

CE COMPONENT BOX W/FILTER, 20A FUSE

1.13.6 Tilt Switch Wiring

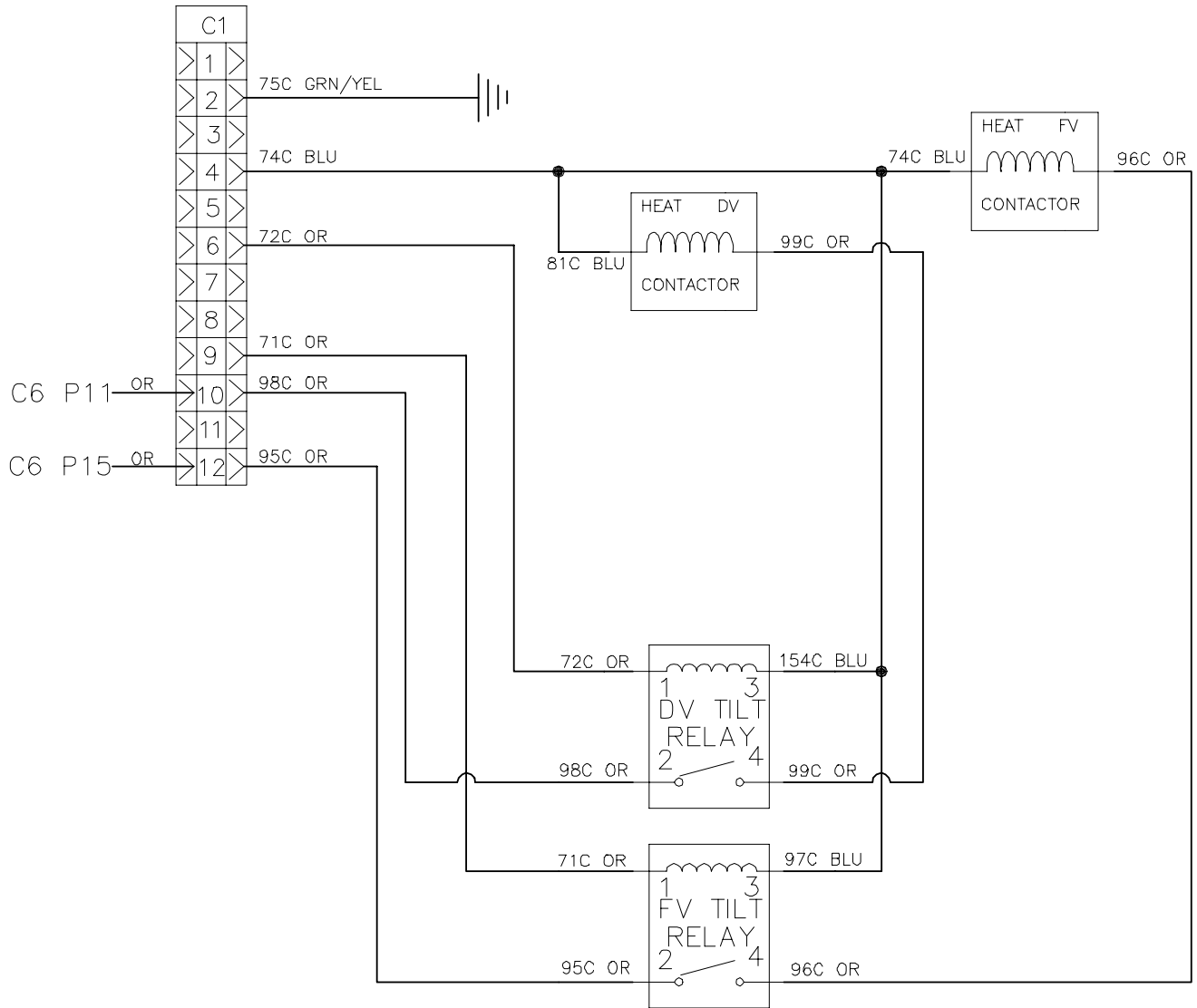

8051612B

1.13.7 Contactor –17kW Full Vat DELTA Configuration Solid State Relay 208-250V

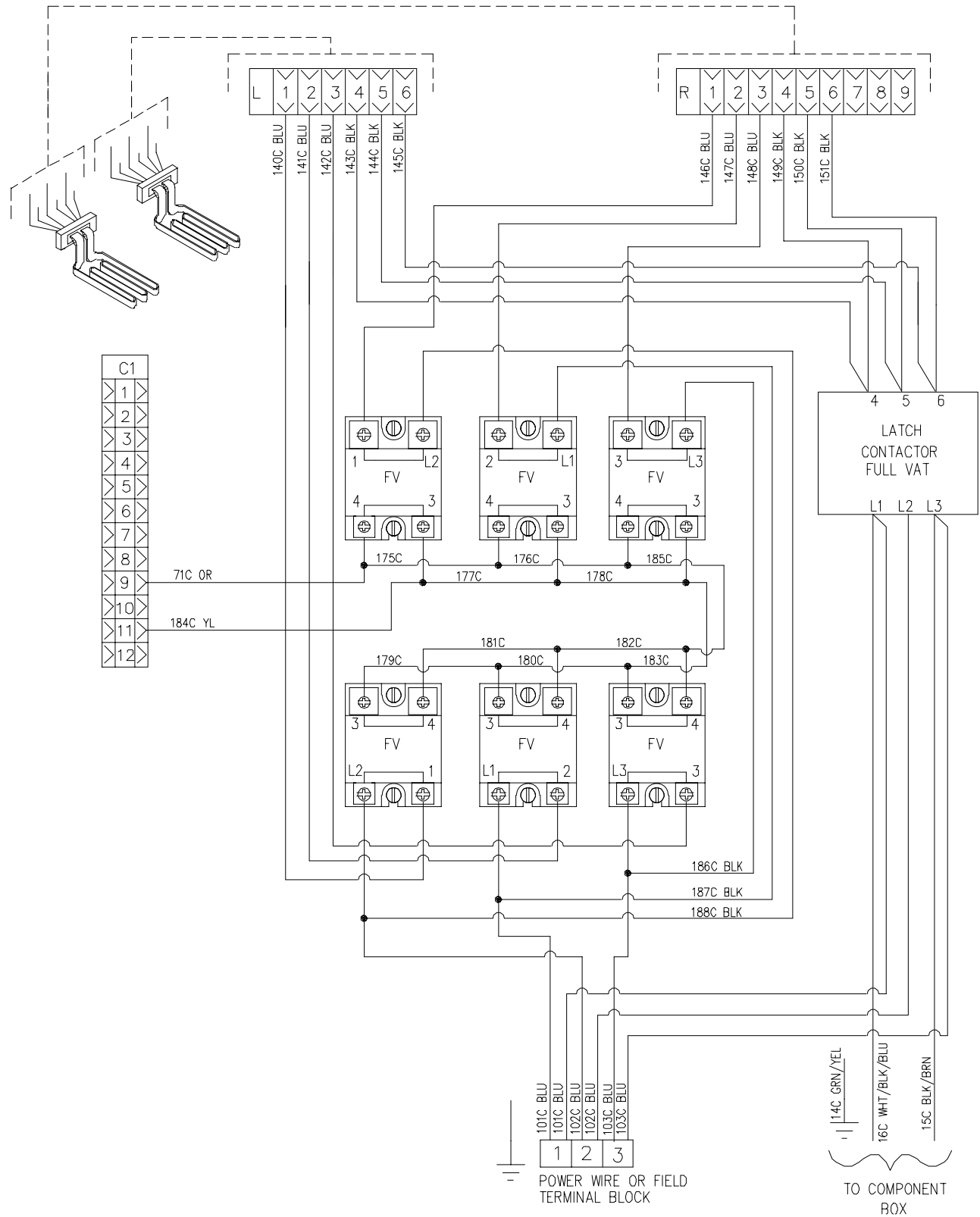

8051873A

1.13.8 Contactor –17kW Full Vat DELTA Configuration Mechanical 208-250V

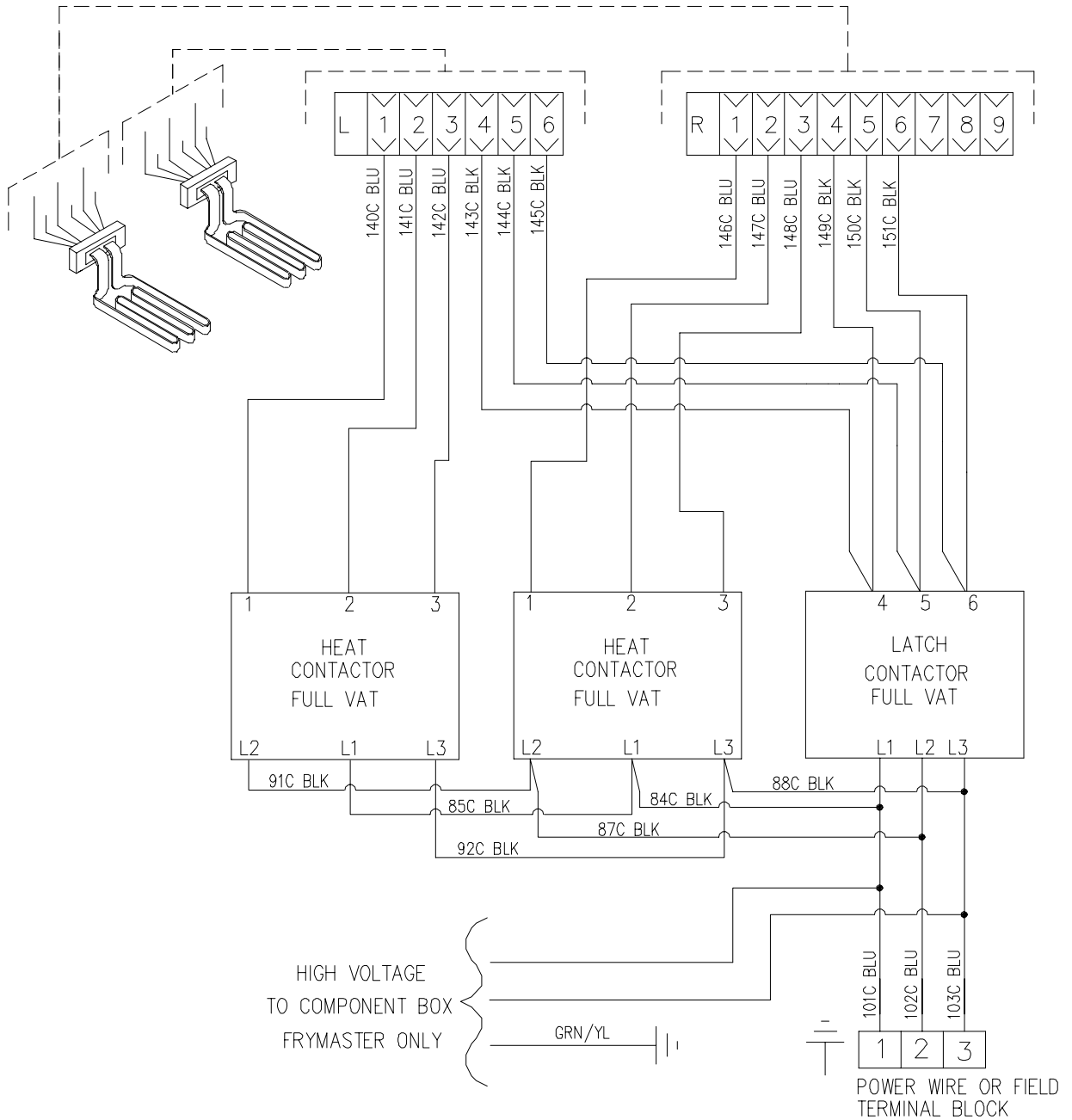

8051891A

1.13.9 Contactor –17kW Full Vat DELTA Configuration Mechanical 480V

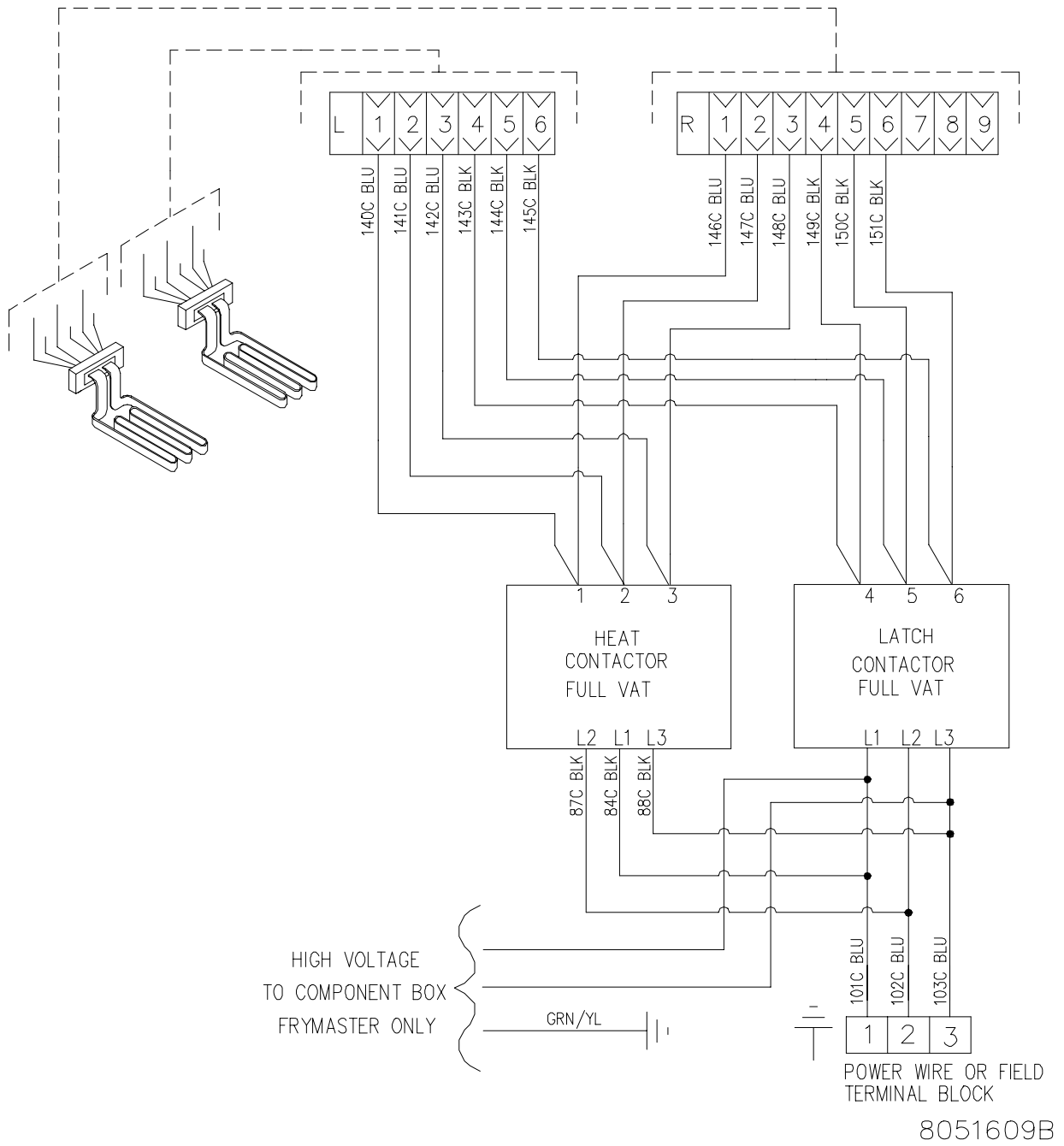

1.13.10 Contactor –17kW Dual Vat DELTA Configuration Solid State Relay 208-250V

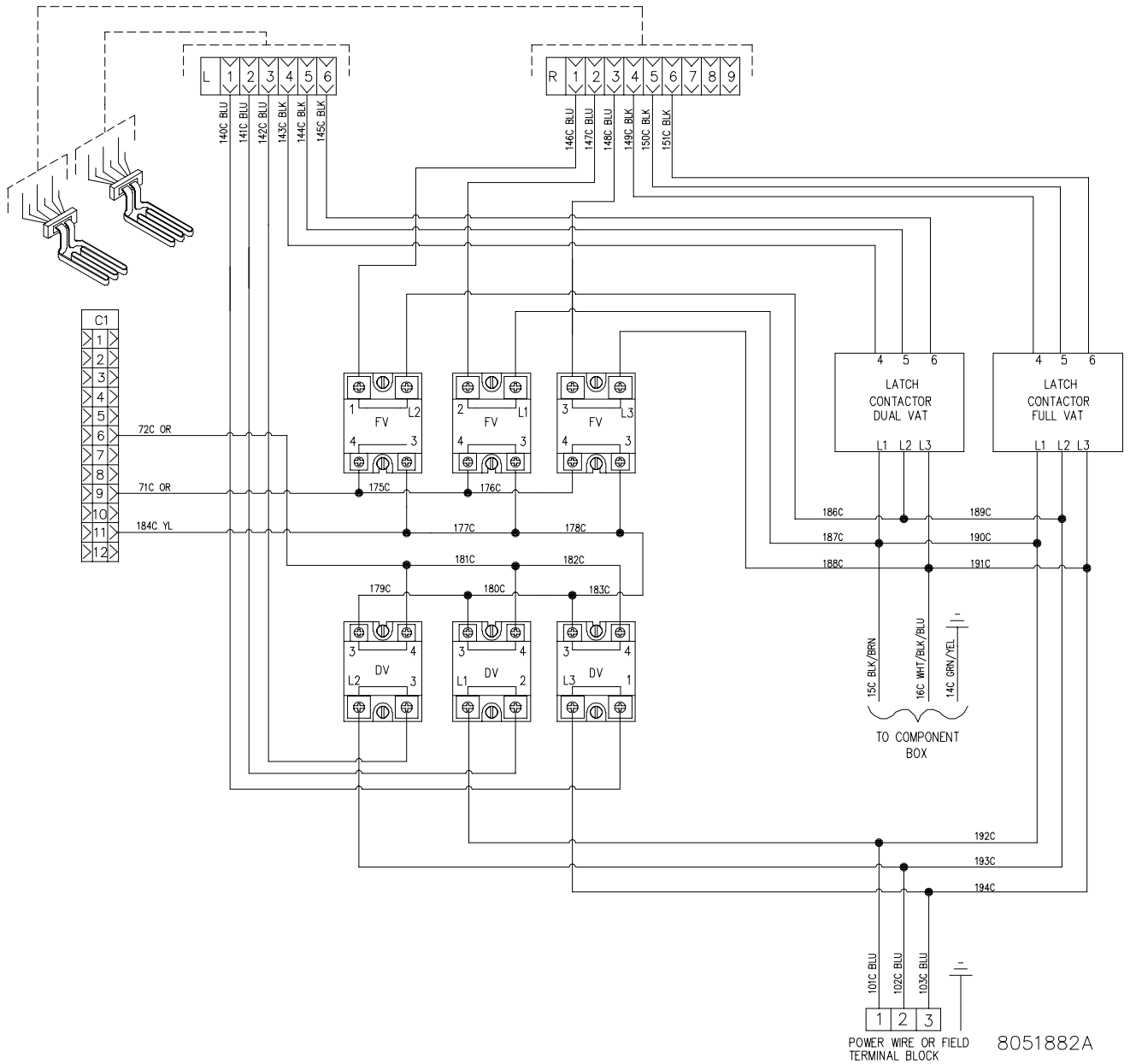

1.13.11 Contactor –17kW Dual Vat DELTA Configuration Mechanical 208-250V/480V

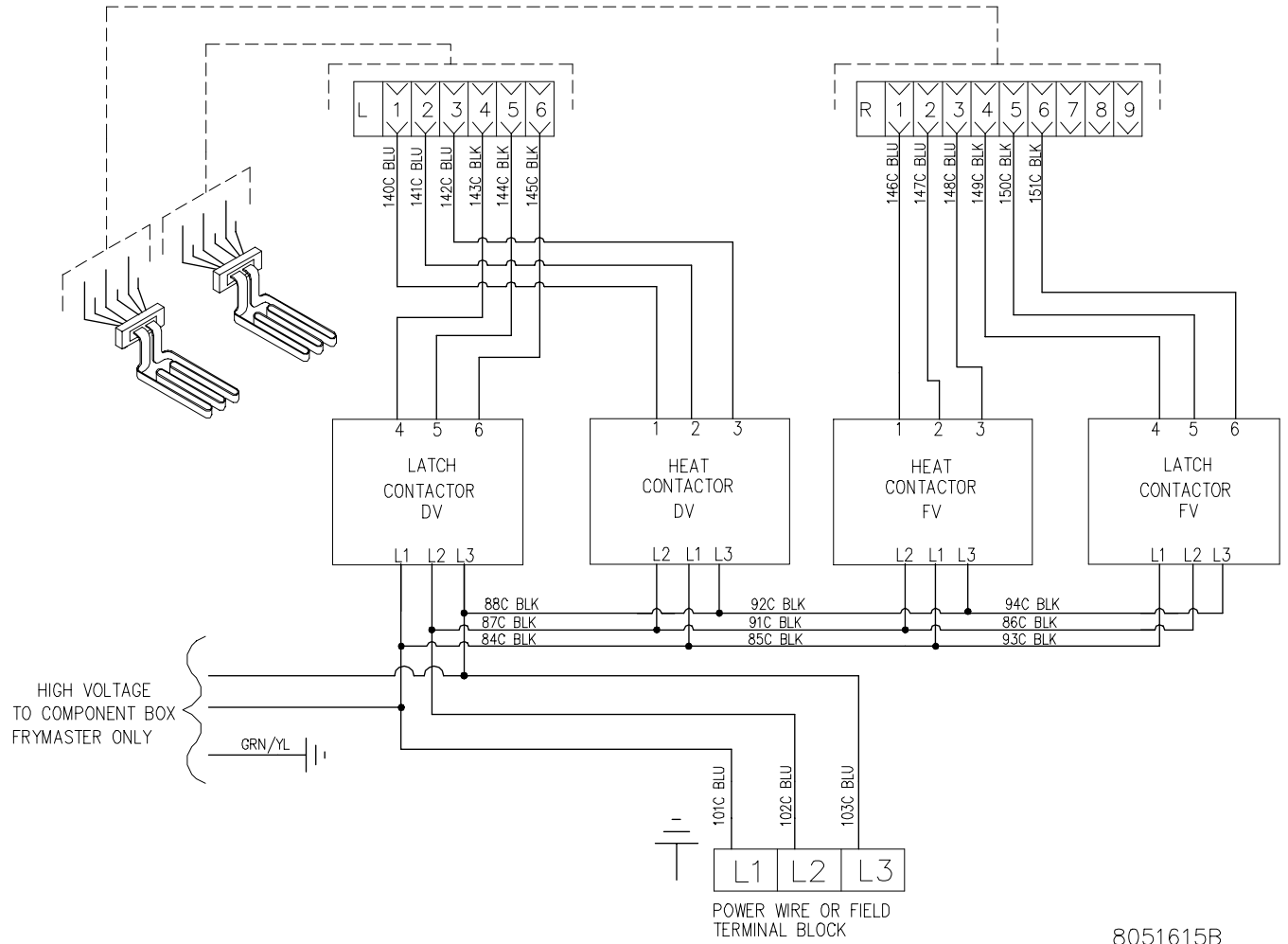

8051615B

1.13.12 Contactor –22kW Full Vat DELTA Configuration Solid State Relay 208-250V

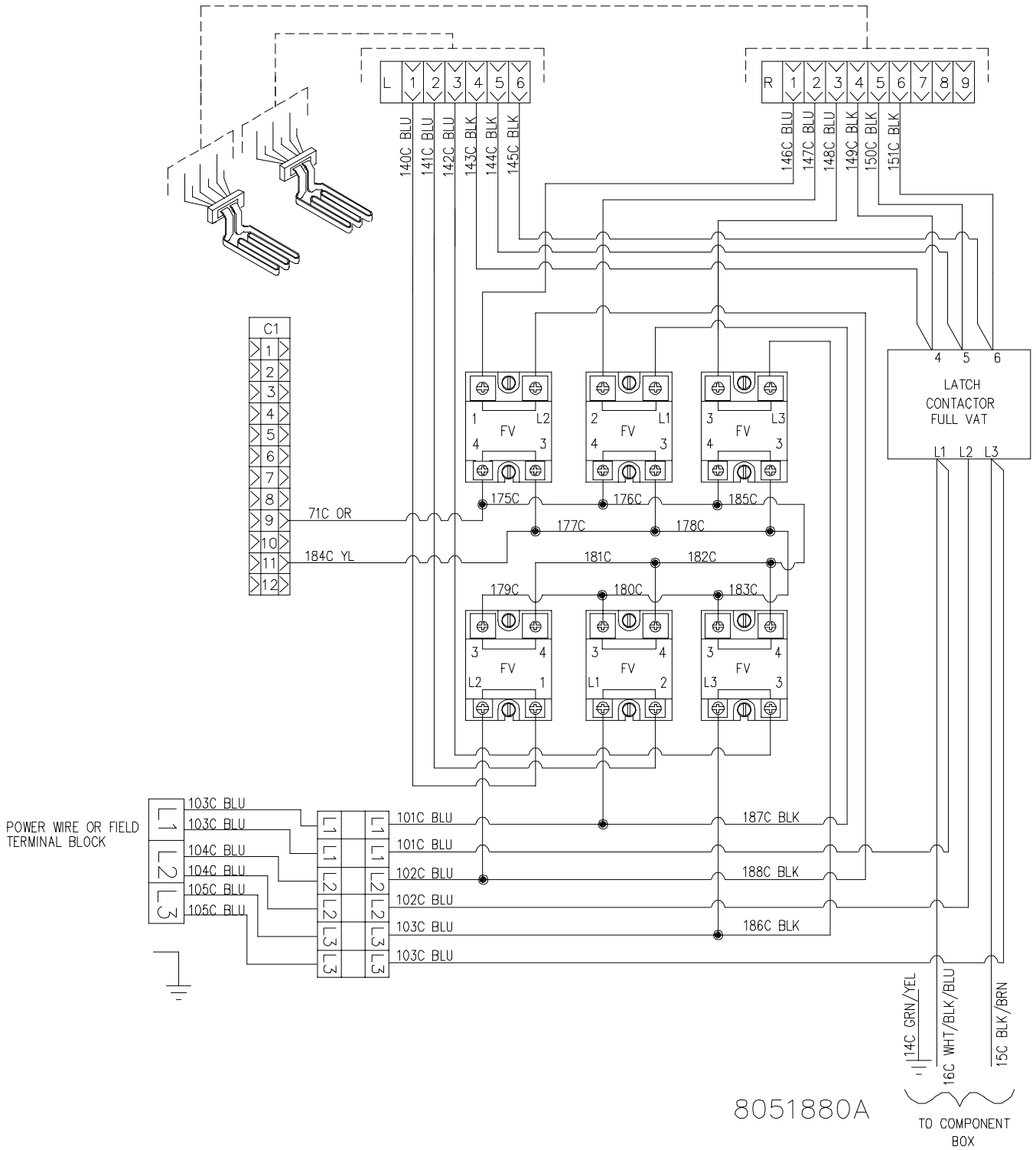

1.13.13 Contactor –22kW Full Vat DELTA Configuration Mechanical 208-250V

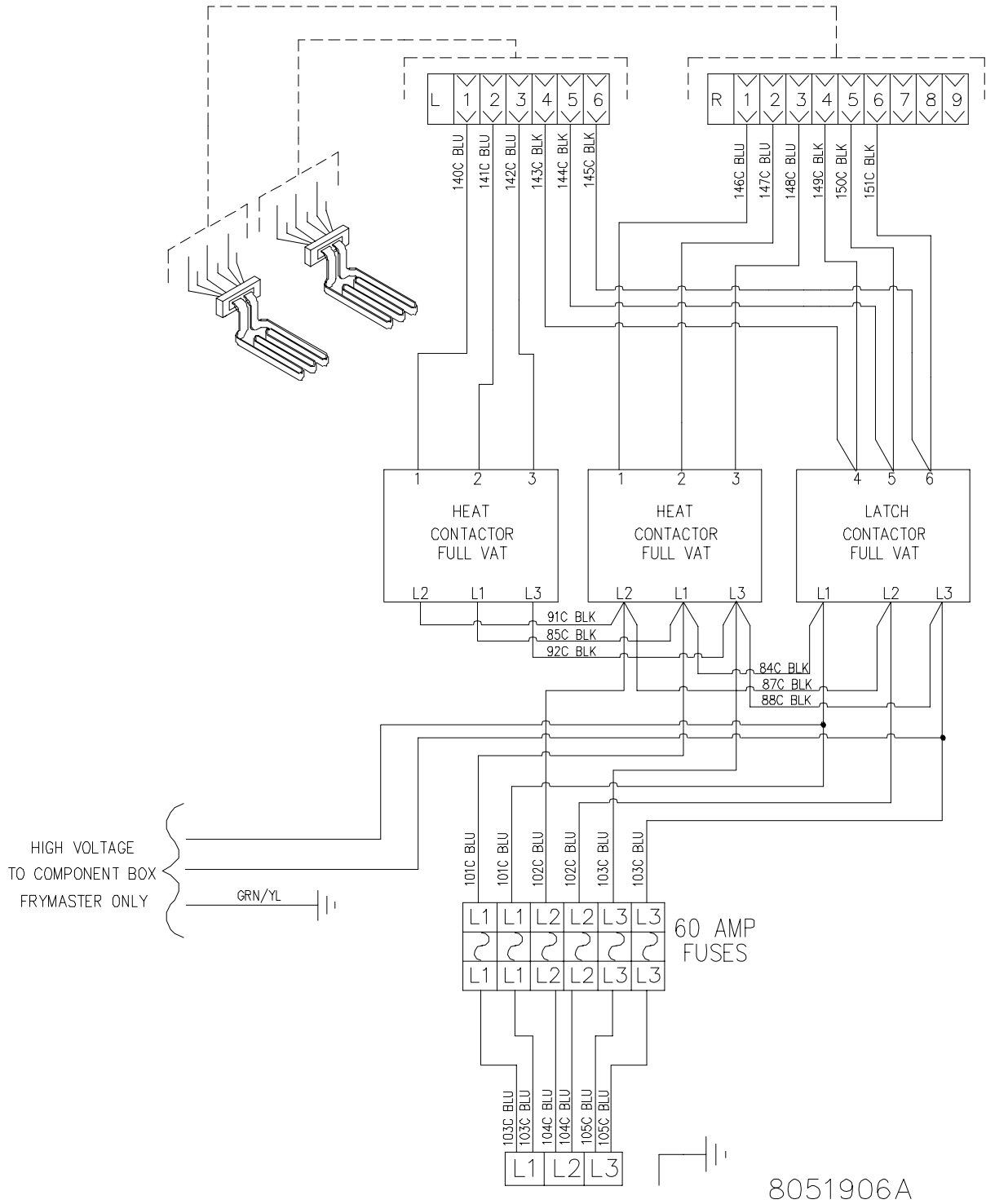

1.13.14 Contactor –22kW Full Vat DELTA Configuration Mechanical 480V

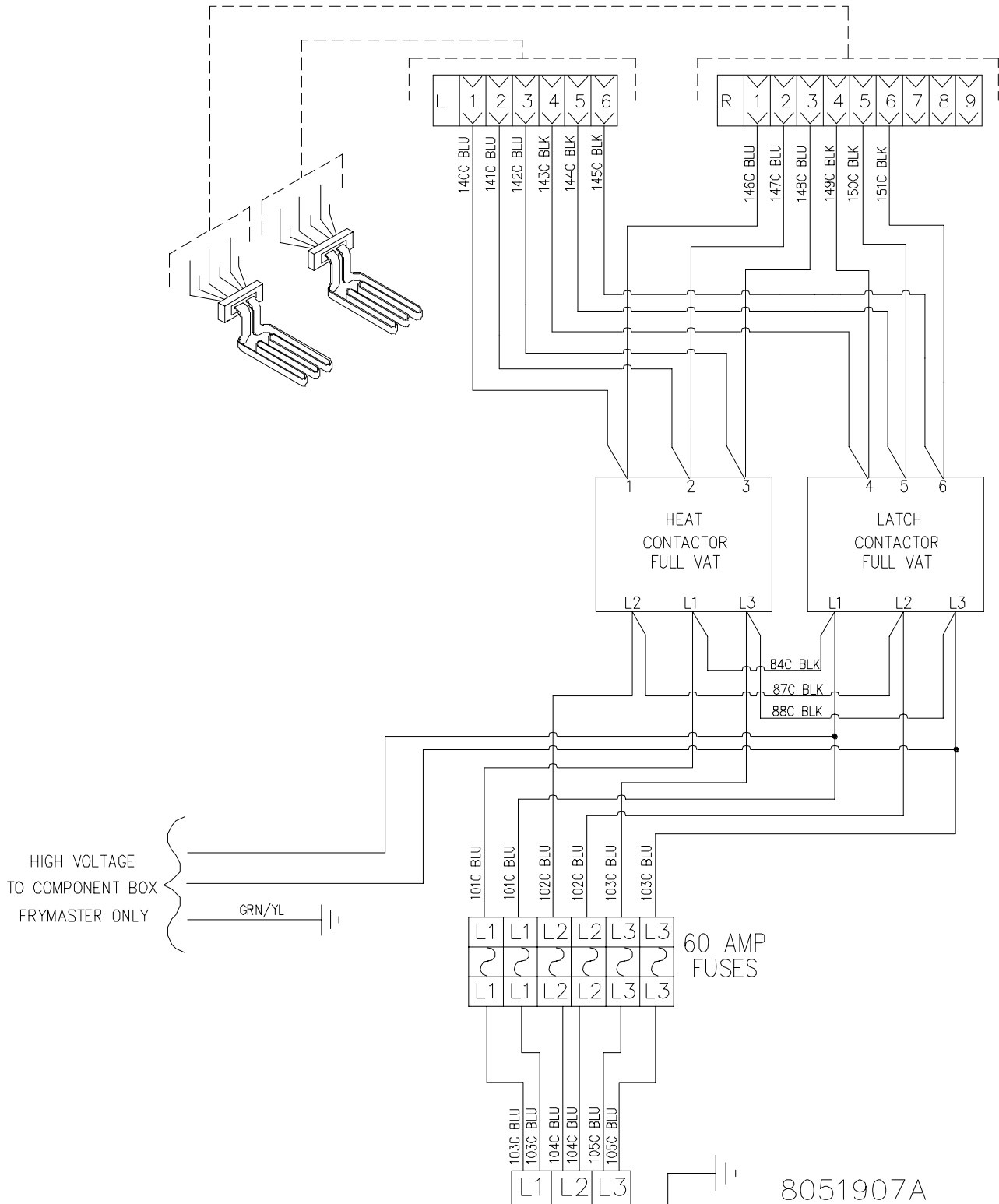

1.13.15 Contactor –17kW and 22kW Full Vat WYE Configuration Export Solid State Relay 208-250V

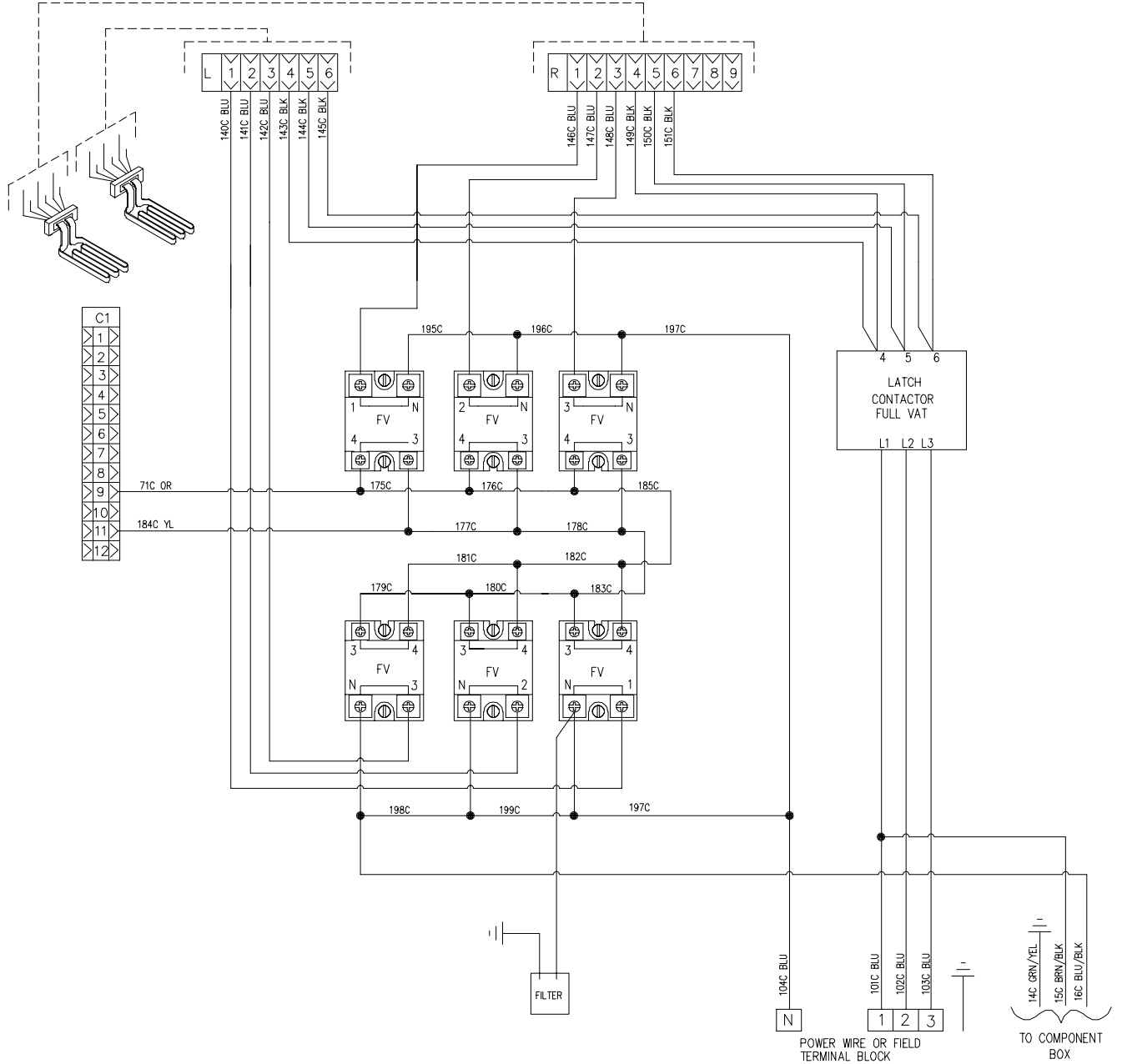

8051883A

**1.13.16 Contactor –17kW and 22kW Full Vat WYE Configuration Export Mechanical
208-250V/480V**

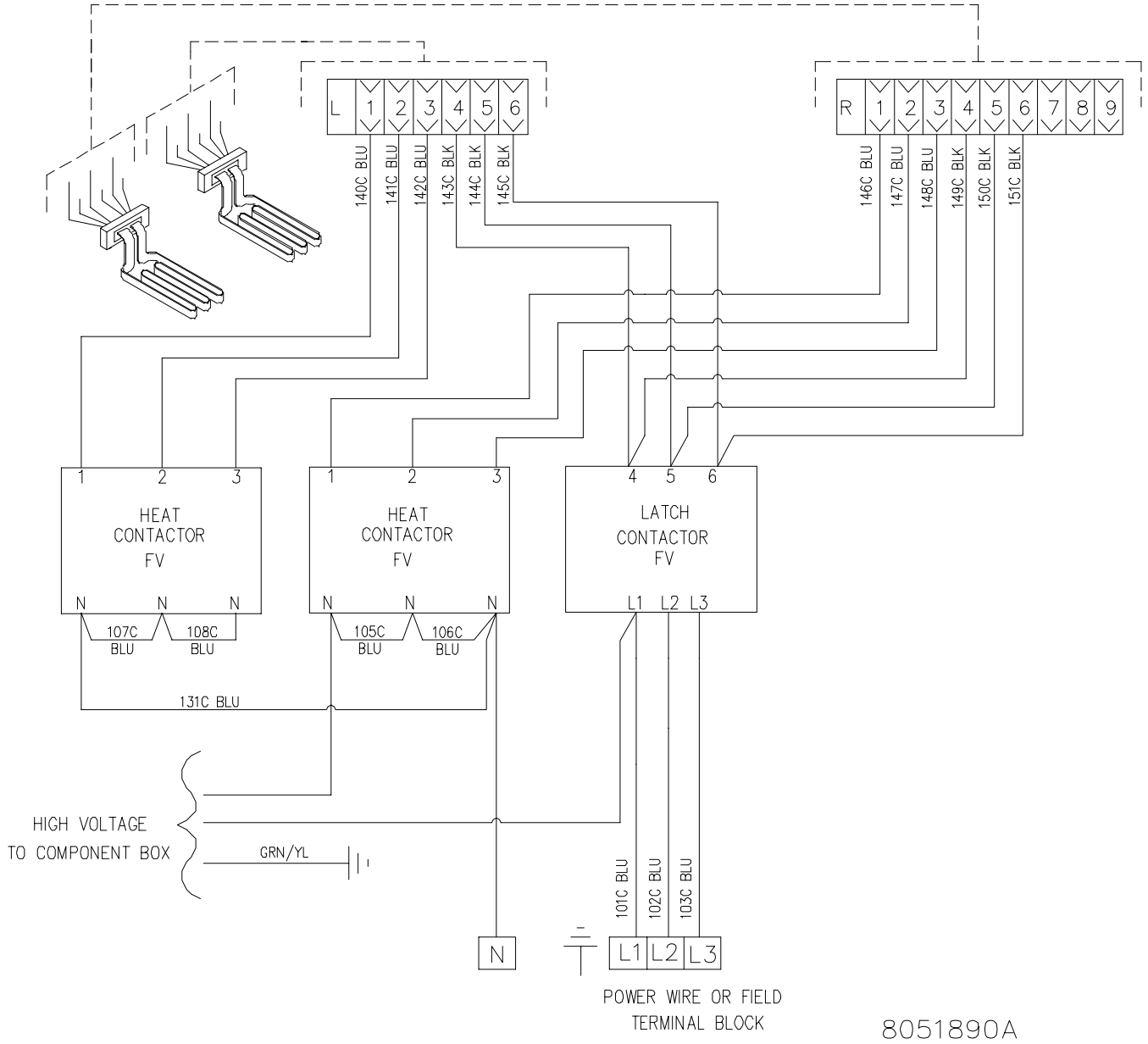

1.13.17 Contactor –17kW Dual Vat WYE Configuration Export Solid State Relay 208-250V

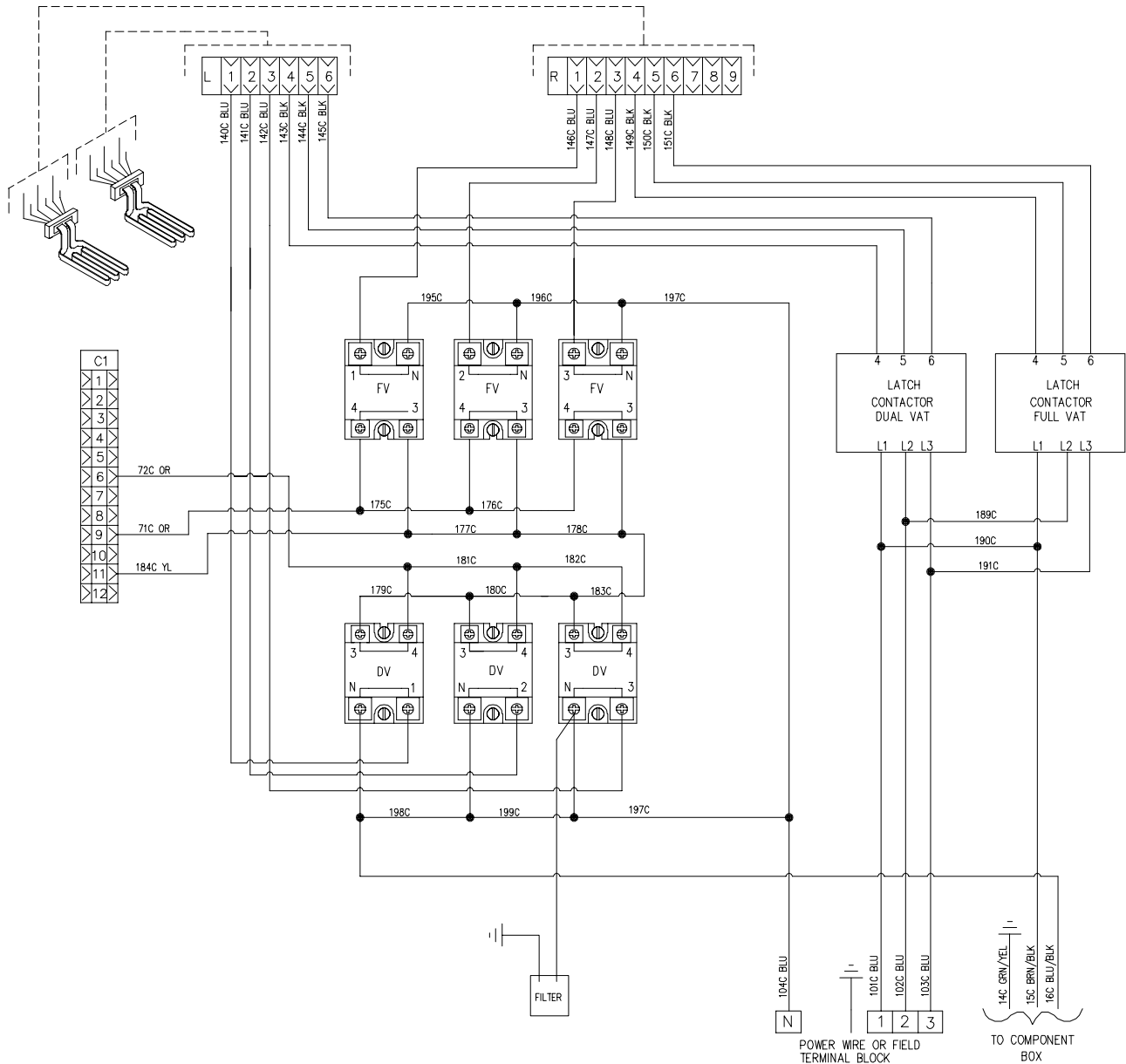

8051885A

1.13.18 Contactor –17kW Dual Vat WYE Configuration Export Mechanical 208-250V

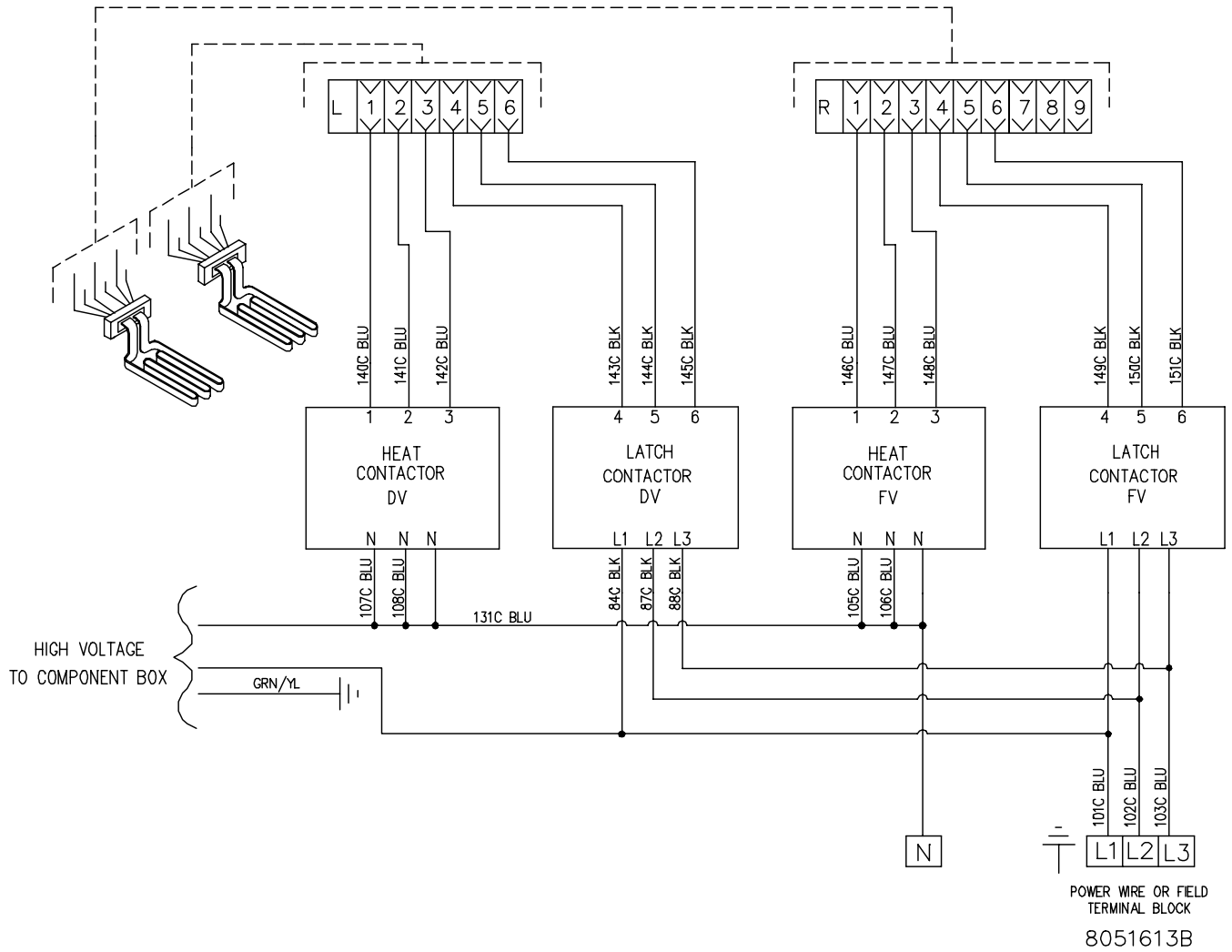

1814E SERIES ELECTRIC FRYERS

CHAPTER 2: PARTS LIST

2.1 Accessories

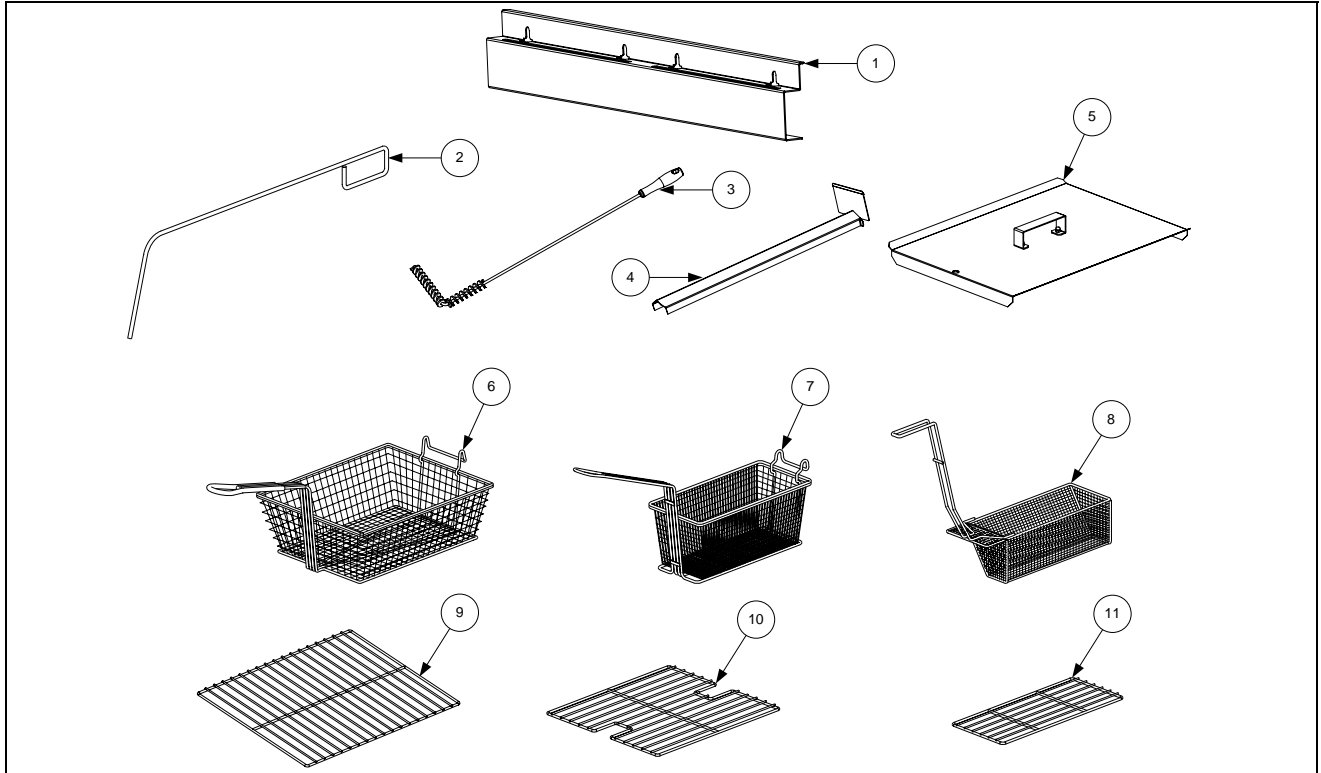

ITEM	PART #	COMPONENT
1	230-4318	Hanger, Basket 1814 Single Non-Filter
	230-8464	Hanger, Basket 1814 Double
	230-8463	Hanger, Basket 1814/RE Double
	230-8462	Hanger, Basket RE/1814 Double
	230-8319	Hanger, Basket 1814/RE/1814 Triple
2	803-0197	Cleanout Rod, 27-inch
3	803-0278	Brush, Frypot
4	823-8190	Connecting Strip, Frypot
5	106-9620	Cover, 1814
	806-3068	Cover, Full-Vat Frypot RE
	806-3071	Cover, Dual-Vat Frypot RE
6	803-0099	Basket, Full-Vat
7	803-0271	Basket, Dual-Vat (Twin)
8	803-0122	Sediment Tray RE, Left Dual-Vat
*	803-0123	Sediment Tray RE, Right Dual-Vat
*	803-0113	Sediment Tray RE, Full-Vat
9	803-0380	Rack, 1814
10	803-0132	Rack, RE Full-Vat Basket Support
11	803-0106	Rack, RE Dual-Vat Basket Support
*	803-0002	Powder, Filter (80 1-Cup Applications)
*	803-0289	Pack, 100-Sheet Filter Paper

* Not illustrated.

2.2 Basket Lift Assembly and Associated Parts

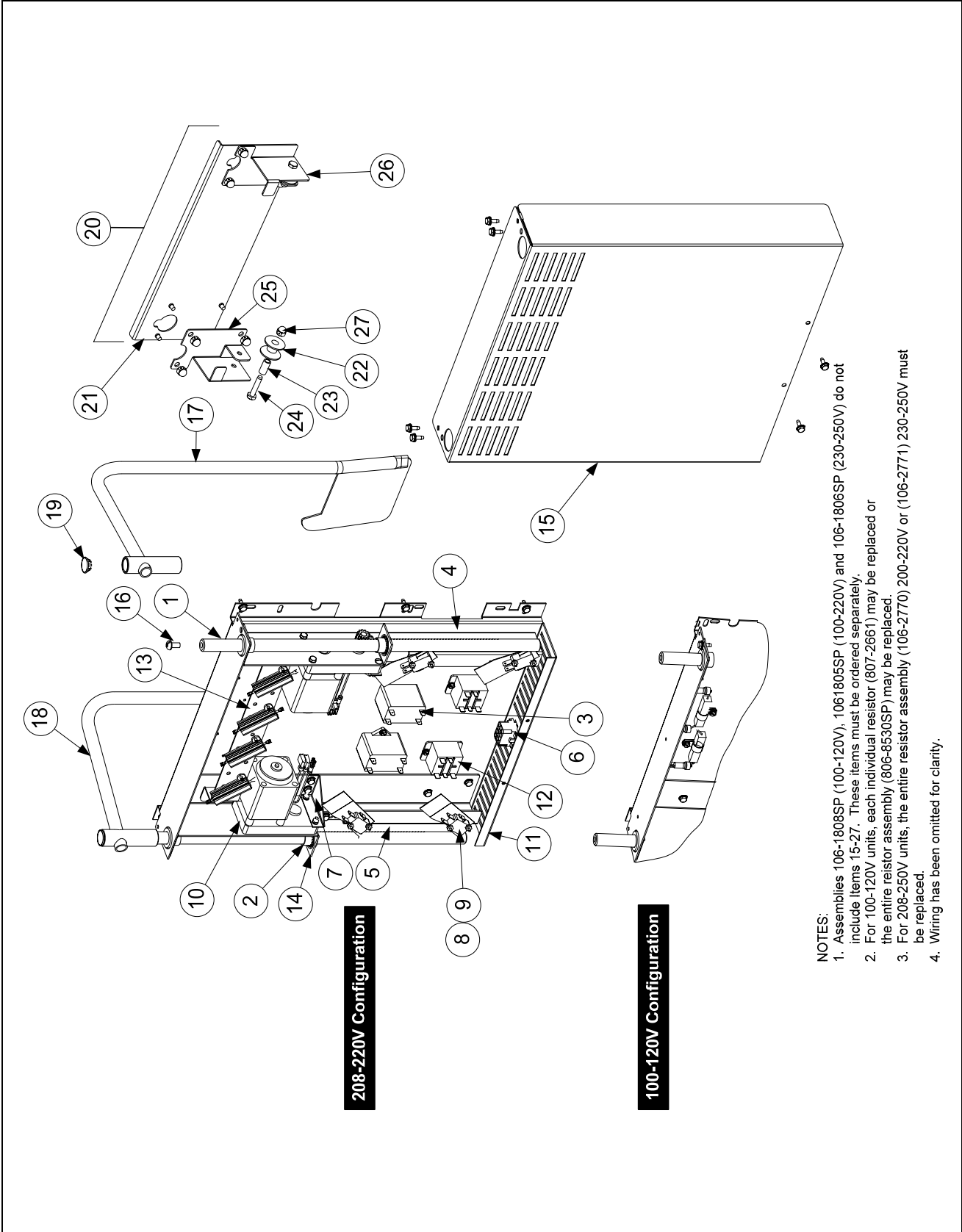

2.2 Basket Lift Assembly and Associated Parts cont.

ITEM	PART #	COMPONENT
		Basket Lift Assemblies (see Note 1 in illustration)
	106-1808SP	Basket Lift Assembly, 100-120VAC w/Relay (Items 1-20) shown
	106-1805SP	Basket Lift Assembly, 200-220VAC w/Relay (Items 1-20) shown
*	106-1806SP	Basket Lift Assembly, 230-250VAC w/Relay (Items 1-20) not shown
1	810-1012	Rod, Basket Lift
2	813-0035	Bushing, Bronze
3	807-2513	Capacitor, 12.5 µFd 330VAC
4	901-8499	Chassis, Left Basket Lift
5	902-8499	Chassis, Right Basket Lift
6	807-0159	Connector, 12-Pin Female
7	900-5529	Gusset, Basket Lift Motor
8	812-0442	Insulation, Microswitch
9	807-2572	Microswitch
10	806-5964SP	Motor Assembly, 208-240VAC Modular Basket Lift
11	200-2942	Mount, Modular Basket Lift
12	807-1683	Relay, 12VDC
13		Resistor Assembly
	806-8530SP	100-120V Modular Basket Lift (see Note 2 in illustration)
	106-2770SP	208-220VAC Modular Basket Lift
*	106-2771SP	230-250VAC Modular Basket Lift
14	809-0082	Ring, Bushing Retainer
15	910-4776	Cover, Modular Basket Lift Rear S/S (Use 900-4776 for Mild Steel)
16	809-0127	Screw, ¼-20 X ½-inch Slotted Round Head
17	823-7986	Arm, Left Basket Lift
18	823-7987	Arm, Right Basket Lift
19	810-0179	Button, Plug
20	108-2743SP	Roller Assembly, Basket Lift
21	108-2860	Mount, Basket Lift Roller
22	810-0194	Roller, Basket Lift
23	810-0374	Spacer, Basket Lift Roller
24	809-0508	Bolt, ¼-20 X 1¼ -Inch
25	823-7980	Guide, Basket lift Left
26	823-8023	Guide, Basket lift Right
27	809-0990	Nut, ¼-20 Cap
*	824-1477	Tray, Drip Right
*	824-1476	Tray, Drip Left
		Wire Assemblies
*	WIR-0166SP	Wire Bundle, 200-250VAC Basket Lift w/Relay
*	106-5962	Wiring Harness, RE Series Electric Basket Lift (Plugs into Item 6)
*	106-6640	Wiring Harness, RE Series Electric Basket Lift SSR (Plugs into Item 6)

* Not illustrated.

2.3 Doors, Sides, Tilt Housings, Top Caps and Casters

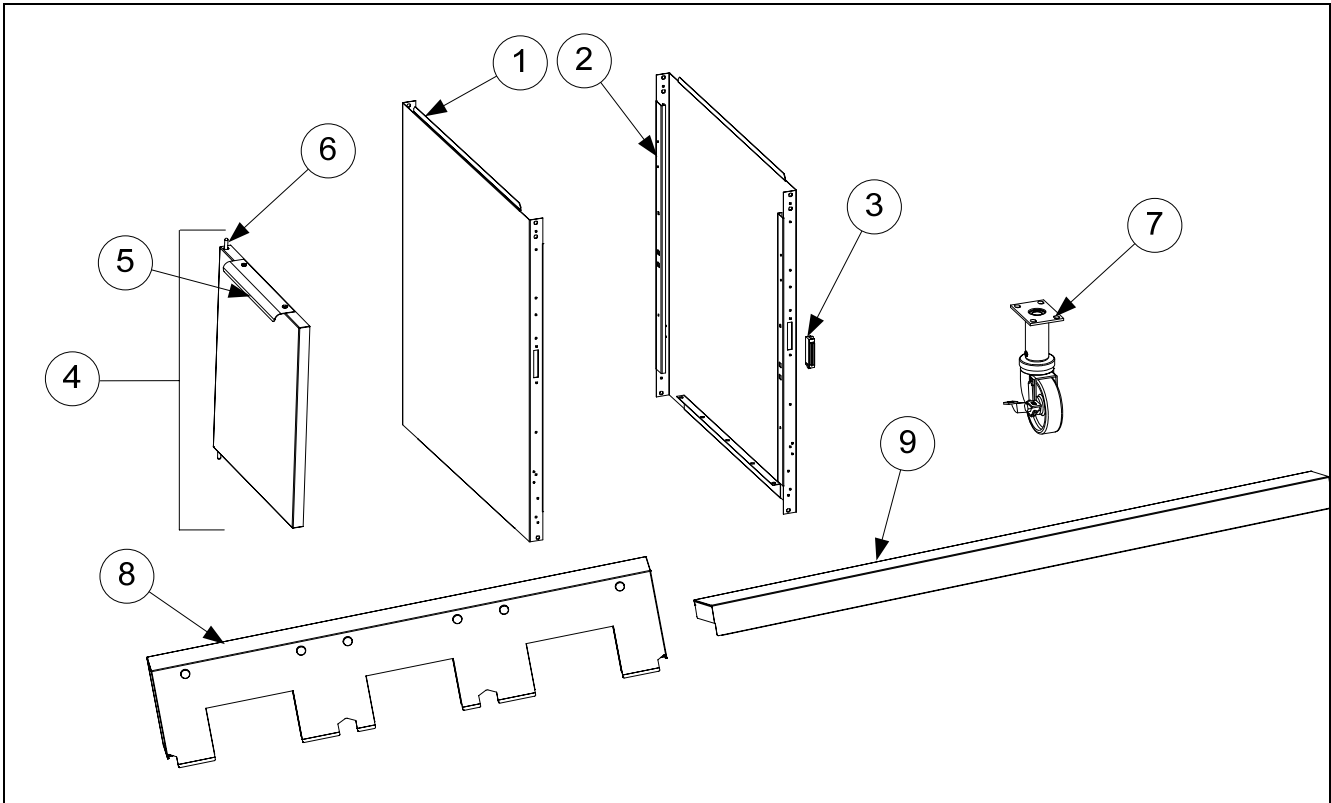

ITEM	PART #	COMPONENT
1	231-8263	Side, Standard Cabinet Left SS (use 221-0323 for Enameled Steel)
2	232-8263	Side, Standard Cabinet Right SS (use 222-0323 for Enameled Steel)
3	810-1105	Magnet, Door
4	106-4309	Door, Left or Right 1814 (Left shown – move handle to bottom for right)
	108-3463	Door, Left or Right RE (Left shown – move handle to bottom for right)
5	210-8077	Handle, Door
6	106-4067	Pin Assembly, Door
*	810-0275	Spring, Door Pin
*	230-7192	Hinge, Door Lower
*	210-8075	Panel, Universal Door 1814 (use 220-8737 for RE)
*	809-0193	Spacers, Mounting Door
7	810-2280	Caster adjustable 3" with Brake
8	823-8038	Tilt Housing Single 1814 non-filter
	823-8036	Two Station 2-1814
	823-8054	Two Station 1814/RE
	823-8050	Two Station RE/1814
	823-8078	Three Station 1814/RE/1814
9	108-2910	Top Cap Single 1814
	108-2905	Two Station 2-1814
	108-3003	Two Station 1814/RE
	108-2994	Two Station RE/1814
	108-2865	Three Station 1814/RE/1814

* Not illustrated.

2.4 Drain System Components

2.4.1 Drain Tube Sections and Associated Parts

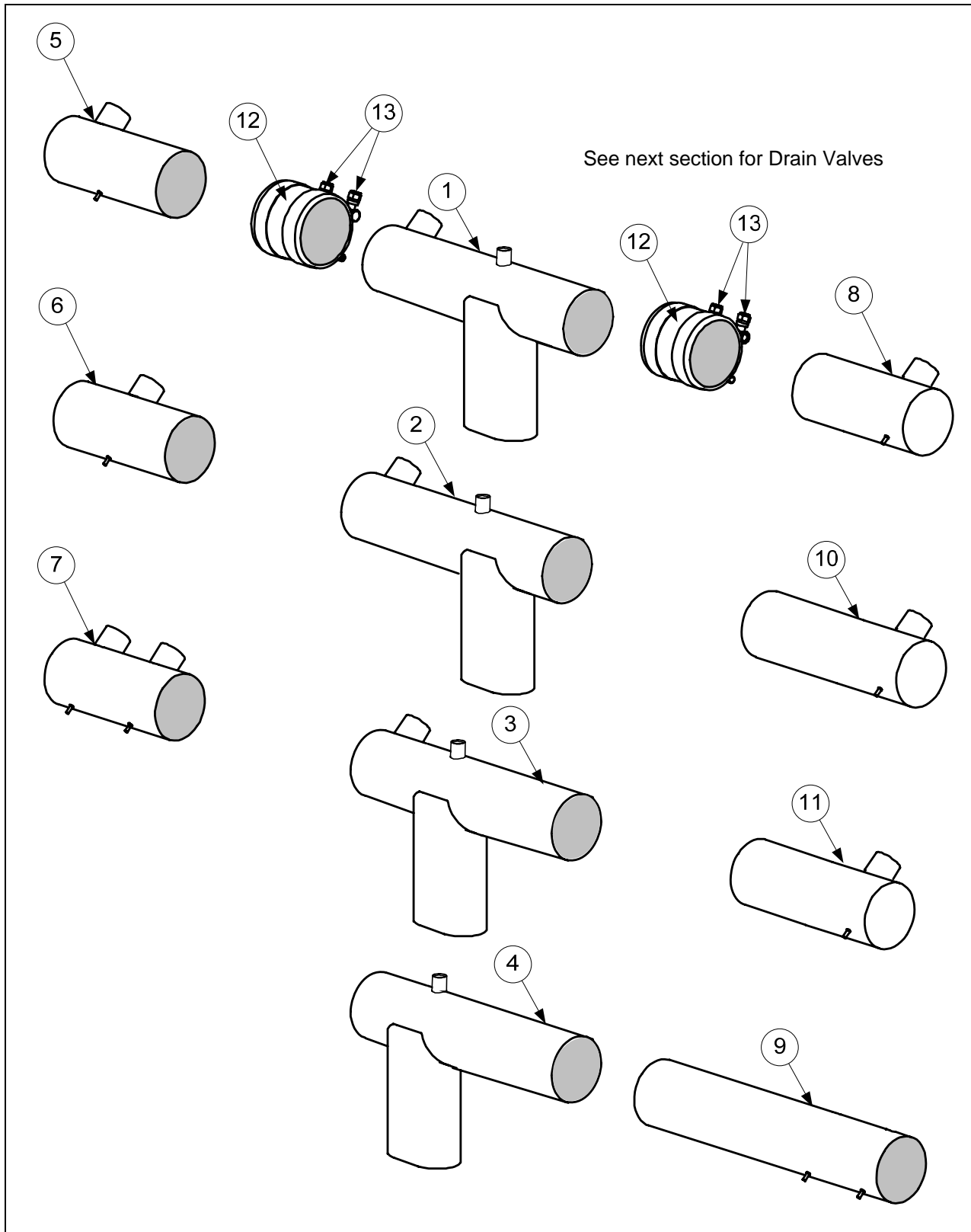

2.4.1 Drain Tube Sections and Associated Parts cont.

ITEM	PART#	COMPONENT
1	823-8042	Drain Tube, Dump Left Closed/Right End Open
2	823-8049	Drain Tube, Dump Left Closed/Right End Open
3	823-8053	Drain Tube, Dump Left Closed Both Ends
4	823-8214	Drain Tube, Dump Open Both Ends
5	823-8010	Drain Tube, Left Closed/Right End Open
6	823-8213	Drain Tube, Open Both Ends
7	823-8058	Drain Tube, Dual-Vat, Open Both Ends
8	823-8212	Drain Tube, Left Open/Right End Closed 5.36"
9	812-2235	Drain Tube, Long, Open Both Ends 10.08"
10	823-8046	Drain Tube, Left Open/Right End Closed 8.26"
11	823-8052	Drain Tube, Left Open/Right End Closed 7.76"
12	816-0772	Sleeve
13	809-0969	Clamp
*	816-0665	Vinyl Cap
14	810-3256	Fitting, Quick Connect
*	811-0932	Tubing, Teflon Vent (sold by the foot)

* Not illustrated.

2.4.2 Drain Valves and Associated Parts (Units with Built-In Filtration)

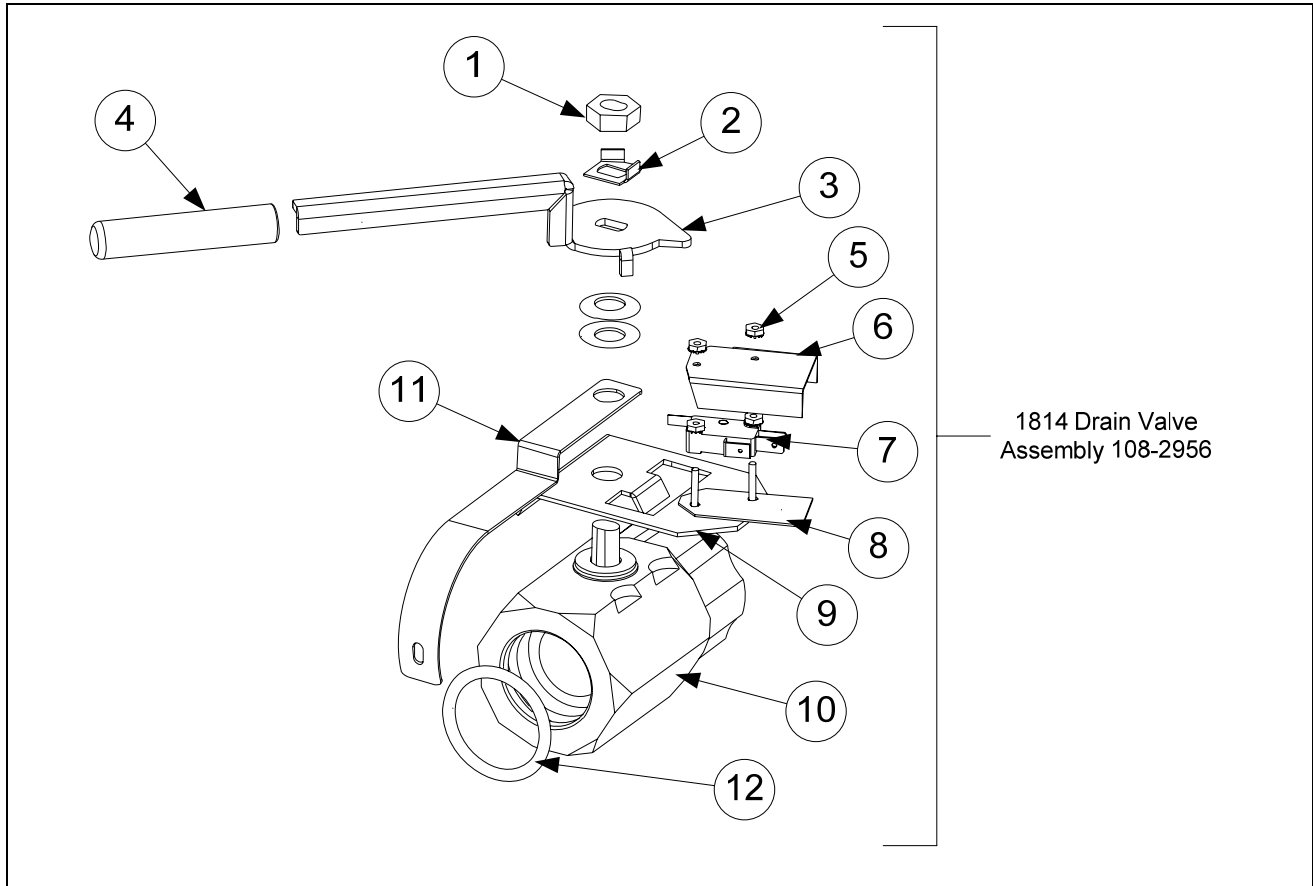

ITEM	PART #	COMPONENT
1	809-0540	Nut, ½-13 2-Way Hex Lock
2	200-1257	Retainer, Nut Drain Valve
3	824-2211	Handle, Drain Valve
4	816-0631	Cap, Red Handle
5	809-0237	Nut, 4-40 Keps Hex
6	901-2348	Cover, Dual Vat Drain Safety Switch
7	807-4936	Microswitch, Gold Plated 1814 General Market
	807-2103	Microswitch, CE Straight Lever
8	816-0220	Insulation, Drain Safety Switch
9	108-2964	Bracket Assembly, Drain Safety Switch
10	810-2784	Valve, 1.25-inch Drain
11	220-8465	Strap, Drain Tube
12	816-0544	O-Ring, Round Drain

* **NOTE:** Two battery 1814 non-filter fryers use 108-2956.

2.4.2 Drain Valves and Associated Parts (Units with Built-In Filtration) cont

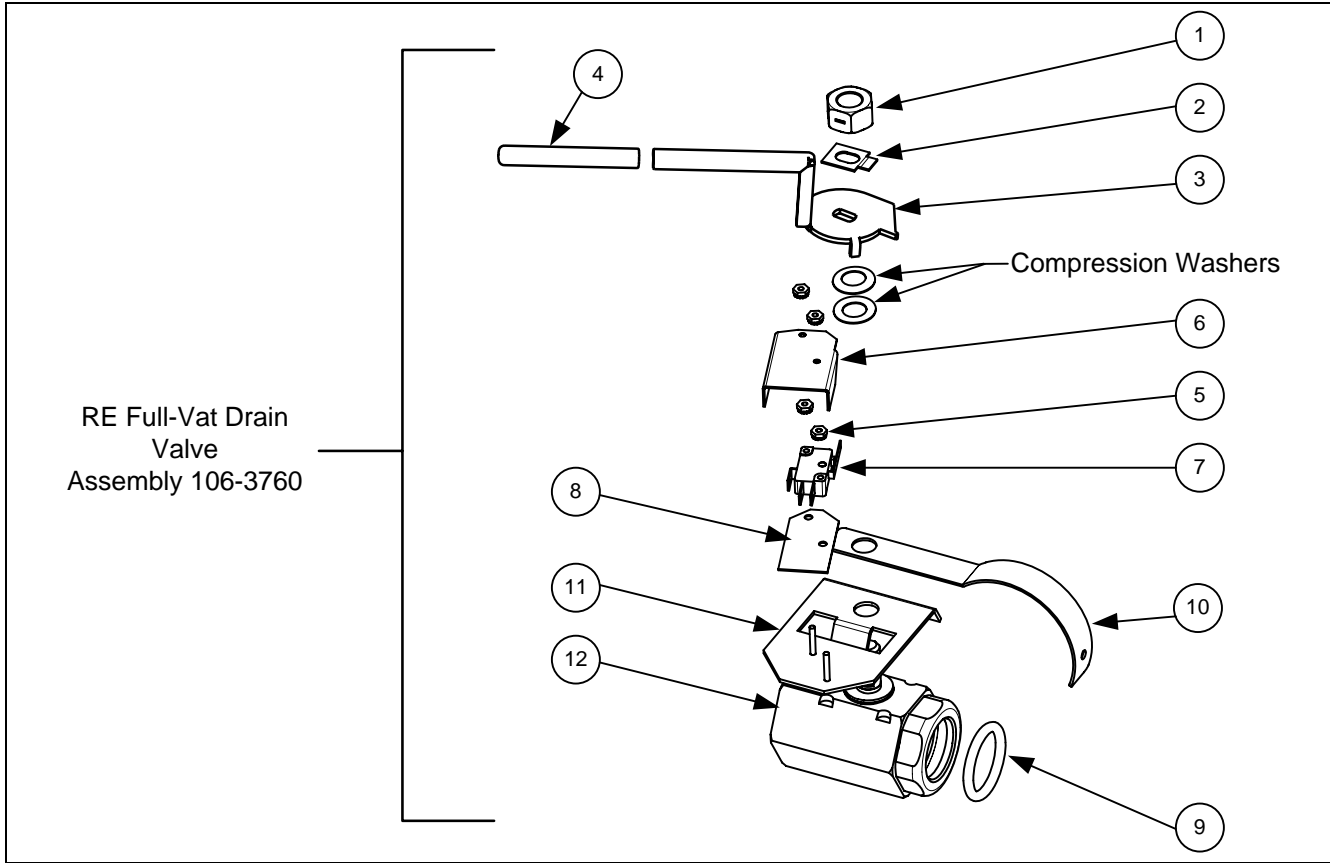

ITEM	PART#	COMPONENT
1	809-0540	Nut, 1/2-13 2-Way Hex Lock
2	900-2936	Retainer, Full-Vat Drain Valve Nut
3	824-1602	Handle, Full-Vat Drain Valve
4	816-0639	Cap, Red Handle
5	809-0237	Nut, 4-40 Keps Hex
6	901-2348	Cover, Dual Vat Drain Safety Switch
7	807-4936	Microswitch, Gold Plated 1814 General Market
	807-2103	Microswitch, CE Straight Lever
8	816-0220	Insulation, Drain Safety Switch
9	816-0135	Round Drain O-Ring
10	200-6496	Support, 3" Drain
11	806-8137	Bracket Assembly, Full-Vat Drain Safety Switch
12	810-1018	Valve, 1.25-inch Full-Vat Drain

2.4.2 Drain Valves and Associated Parts (Units with Built-In Filtration) cont.

RE Dual-Vat Drain Valve
Right Assembly
106-5606

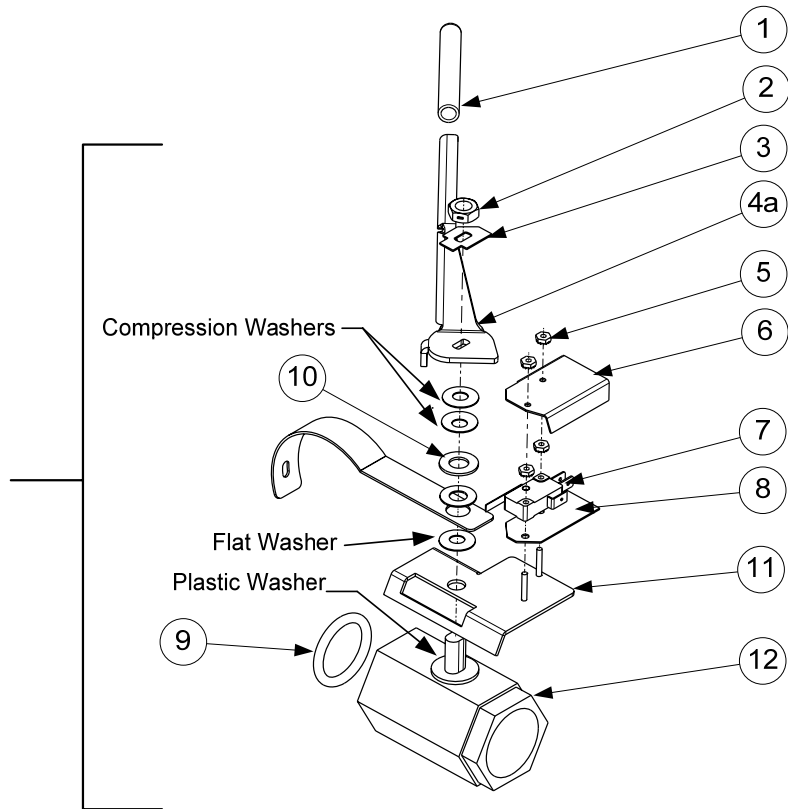

RE Dual-Vat Drain Valve
Left Assembly
106-5607

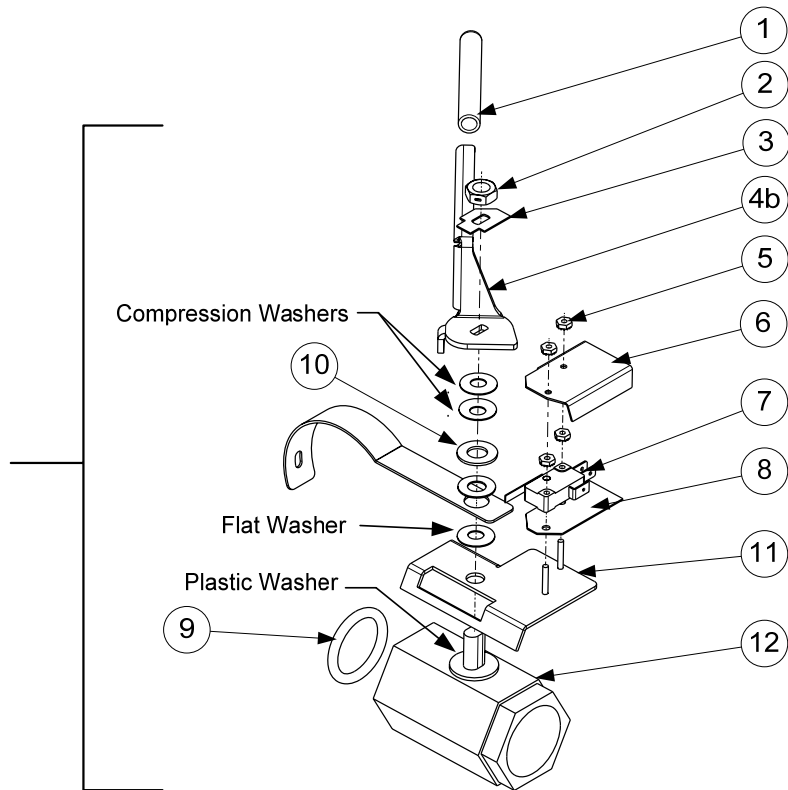

2.4.2 Drain Valves and Assoc. Parts (Units with Built-In Filtration) cont.

ITEM	PART#	COMPONENT
1	816-0639	Cap, Drain Handle
2	809-0539	Nut, 3/8-16 2-Way Hex Lock
3	900-2934	Retainer, Dual-Vat Drain Valve Nut
4a	824-1636	Handle, Dual-Vat Right Drain Valve
4b	824-1637	Handle, Dual-Vat Left Drain Valve
5	809-0237	Nut, 4-40 Keps Hex
6	901-2348	Cover, Dual Vat Drain Safety Switch
7	807-4936	Microswitch, Gold Plated 1814 General Market
	807-2103	Microswitch, CE Straight Lever
8	816-0220	Insulation, Drain Safety Switch
9	816-0135	Round Drain O-Ring
10	809-0196	Washer, 3/8-inch Flat
11	106-2671	Bracket Assembly, Dual-Vat Drain Safety Switch
12	810-1114	Valve, 1-inch Dual-Vat Drain

2.4.3 Drain Valves and Associated Parts (Single Units without Built-In Filtration)

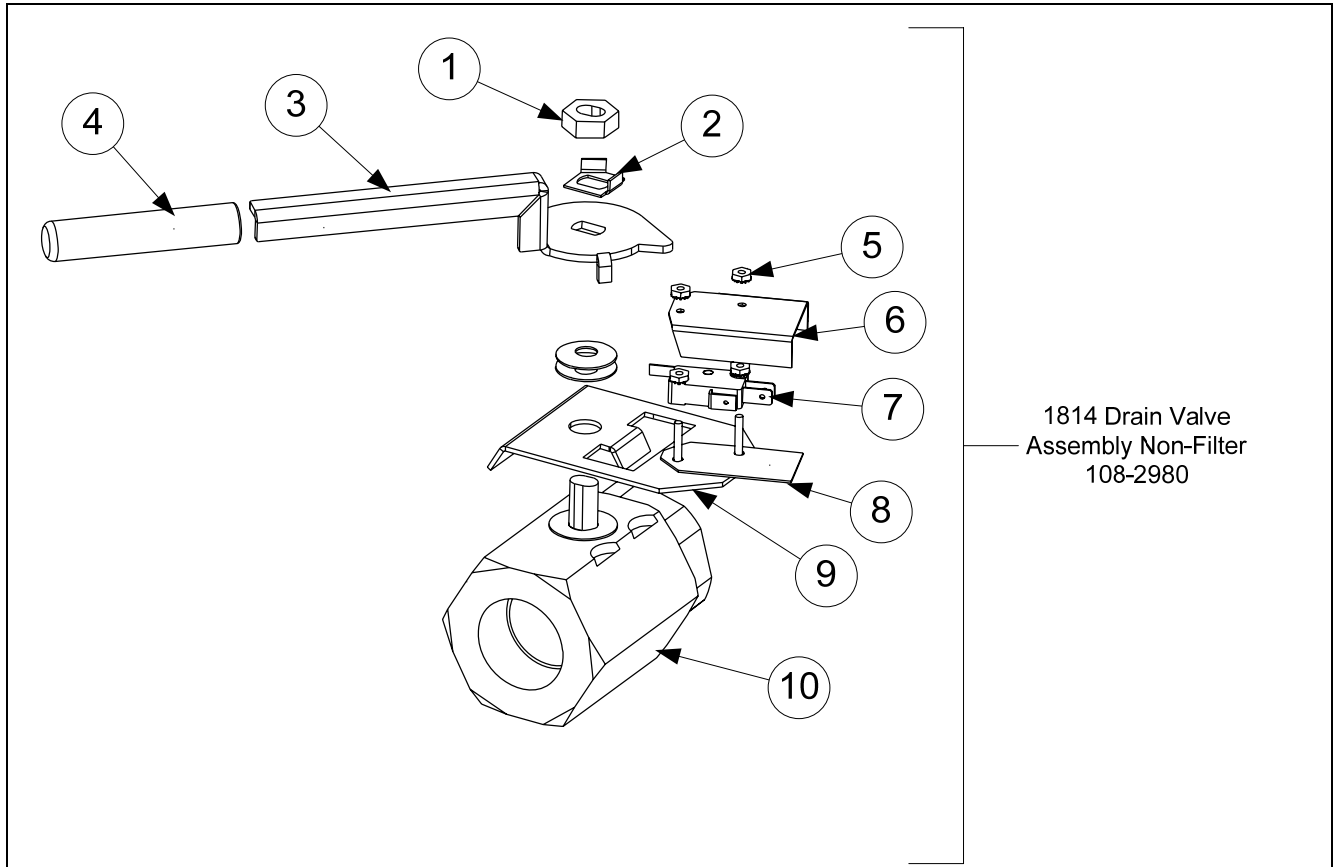

ITEM	PART #	COMPONENT
1	809-0540	Nut, 1/2-13 2-Way Hex Lock
2	200-1257	Retainer, Nut Drain Valve
3	824-2211	Handle, Drain Valve
4	816-0631	Cap, Red Handle
5	809-0237	Nut, 4-40 Keps Hex
6	901-2348	Cover, Dual Vat Drain Safety Switch
7	807-4936	Microswitch, Gold Plated 1814 General Market
	807-2103	Microswitch, CE Straight Lever
8	816-0220	Insulation, Drain Safety Switch
9	108-2964	Bracket Assembly, Drain Safety Switch
10	810-2126	Valve, 1.25-inch Drain

* **NOTE:** Two Battery 1814 non-filter fryers use 108-2956 on page 2-7.

2.5 Electronics and Wiring Components

2.5.1 Component Boxes

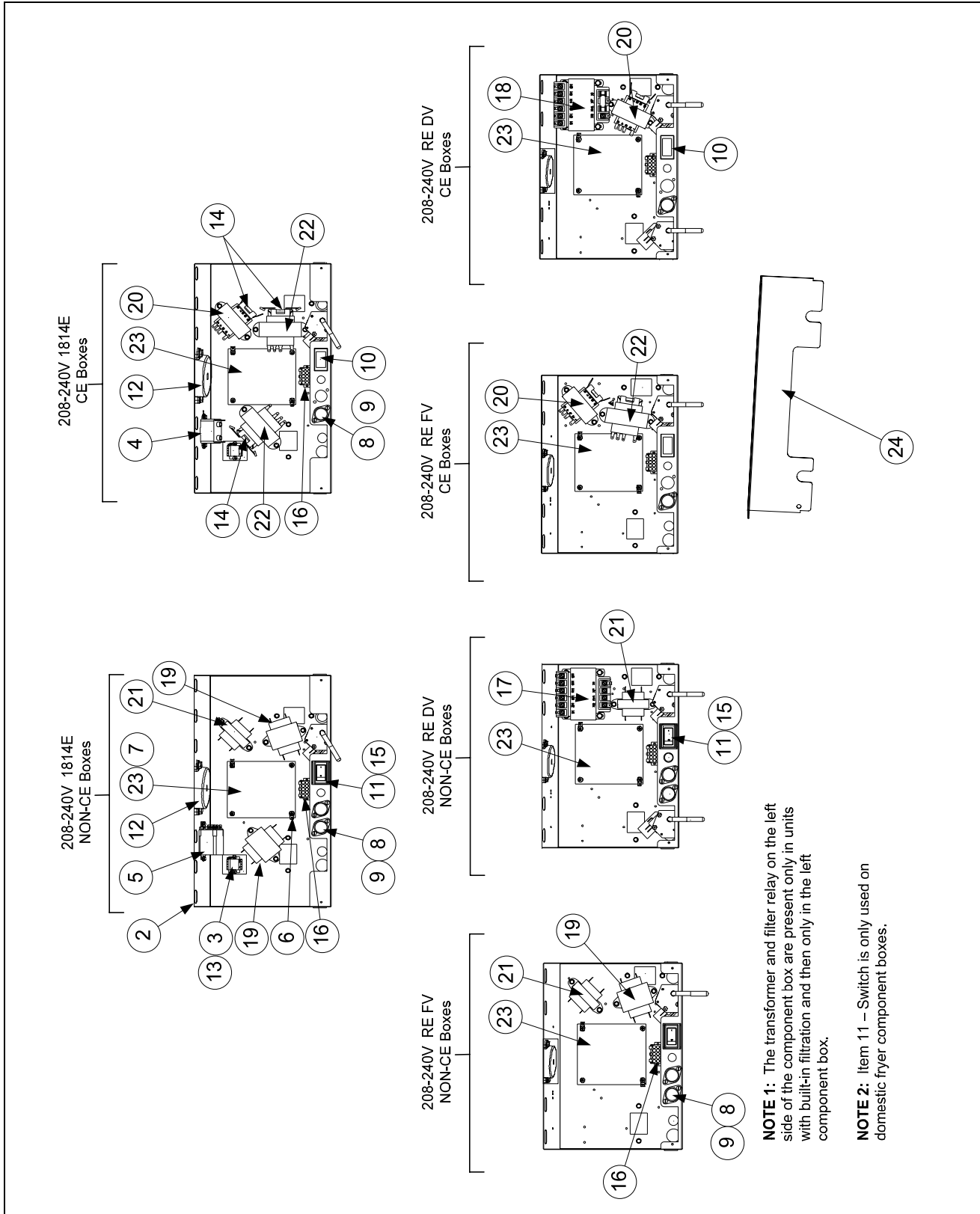

2.5.1 Component Boxes cont.

ITEM	PART #	COMPONENT
1	106-5592	Box Assembly, Component Standard RE
2	106-9226	Box Assembly, Component Standard 1814
3	810-1164	Terminal Block
√ 4	807-0012	Relay, Filter 18 Amp 1/3 HP 24V
√ 5	807-0670	Relay, Filter Mintex DPDT 24V
6	807-0037	Terminal, 1/4-inch Push-on
7	809-0349	Spacer, 4mm X 6mm Aluminum
8	807-0922	Holder, Buss Fuse HPS
√ 9	807-2278	Fuse, 20 Amp
10	807-3575	Plug, Carling Switch Hole (<i>used on some models without a switch</i>)
√ 11	807-4036	Switch
12	810-3141	Sound Device
13	816-0217	Paper, Insulating Terminal Block
√ 14	807-1597	Fuse, 3 AMP Slow-Blow
15	220-5038	Guard, Switch
16	106-6639	Harness Assembly, FV Control
	106-6644	Harness Assembly, DV Control
√ 17	812-2126SP	Transformer, 208-250V/24V 75VA w-out Fuse
√ 18	807-4968	Transformer, 208-250V /24V 75VA
√ 19	807-0680	Transformer, 208-240V/24V 20VA Filter
√ 20	807-2191	Transformer, 208-240V/12V 30VA
√ 21	807-0979	Transformer, 208-240V/12V 43VA
√ 22	807-2180	Transformer, 208-240V 50VA Filter
√ 23	826-2261	Interface Board EPRI, Full- or Dual-Vat
24	220-0565	Guard, Finger RE
	220-4284	Guard, Finger 1814
*	826-2249	RE Hood/Ansul Interlock Kit (includes terminal block, wires and connectors)

* Not illustrated.

√ Recommended parts.

2.5.2 Contactor Boxes

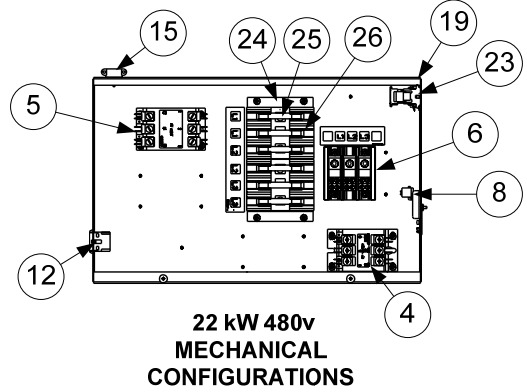
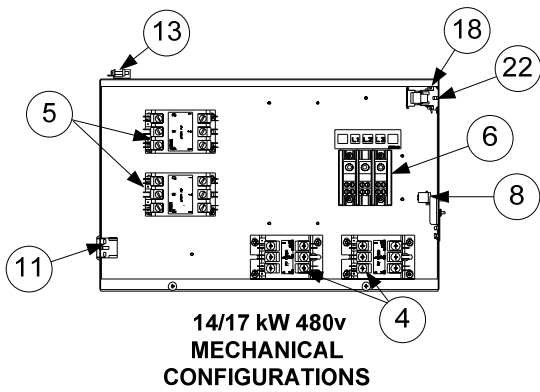
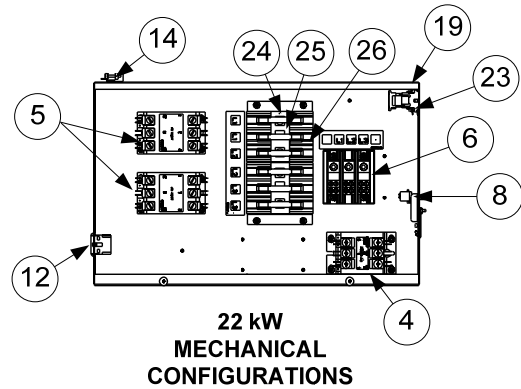
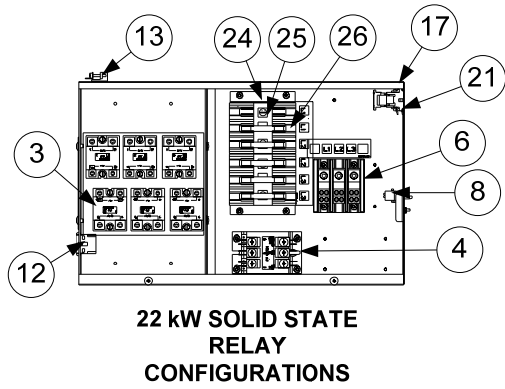
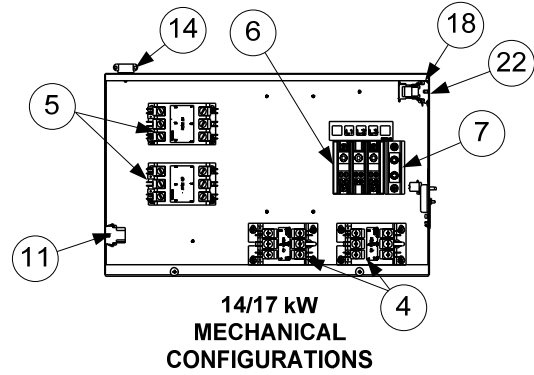
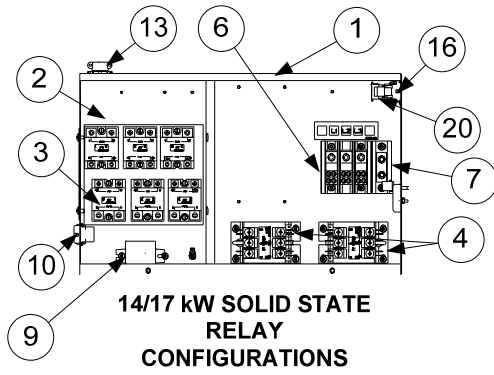

2.5.2 Contactor Boxes

NOTES: Left and right contactor box assemblies are mirror images of one another. With the exception of the box itself, most components of a left-hand assembly are the same as those in the corresponding right-hand assembly and vice versa. The configurations illustrated show most possible components, but a particular configuration may not have all the components shown.

ITEM	PART #	COMPONENT
1	108-2807	Box Assembly, Left Contactor
	108-2806	Box Assembly, Right Contactor
*	220-8502	Cover, Contactor Box
2	807-2749	Heatsink, Solid State Relay
√ 3	826-1562	Kit, Relay, Solid state 40 amp 280V (includes tube of NTE 303 compound)
√ 4	810-1202	Contactor, 24V 40 Amp Mechanical
√ 5	807-2284	Contactor, 24V 50 Amp Mechanical
6	807-3970	Block, Terminal 3 Pole 600V 175A
7	807-1268	Splicer, Terminal Block Single Pole
8	807-0070	Terminal, Ground Lug
9	106-6204	Filter Assembly, Solid State
		Harness Assemblies
10	106-5980	14/17kW Contactor Box Control
11	108-3340	14/17kW Contactor Box Control WYE
12	108-0159	22kW Contactor Box Control
13	106-5815	Contactor Box Power 14/17/22 kW
	106-6554	Contactor Box Power WYE Export 14/17kW WYE Solid State
14	106-5915	Contactor Box Power WYE Export 14/17kW WYE Mechanical
15	106-5872	Contactor Box Power 22kW 480V
16	106-8743	14/17kW Contactor 9-Pin
17	106-8748	22kW Contactor 9-Pin
18	106-8745	RE MDI Contactor 9-pin
19	106-8750	RE-22 MDI Contactor 9-pin
20	106-8742	14/17kW Contactor 6-Pin
21	106-8747	22kW Contactor 6-Pin
22	106-8744	RE MDI Contactor 6-pin
23	106-8749	RE-22 MDI Contactor 6-pin
24	220-8501	Bracket, Fuse Box Mounting
25	807-0501	Fuse Block, BUSS 3-Pole
√ 26	807-2240	Fuse, 60 Amp 300 VAC

* Not illustrated.

√ Recommended parts.

2.5.3 Heating Element Assemblies and Associated Parts

2.5.3.1 Element Assemblies and Hardware

FULL-VAT ELEMENT ASSEMBLY

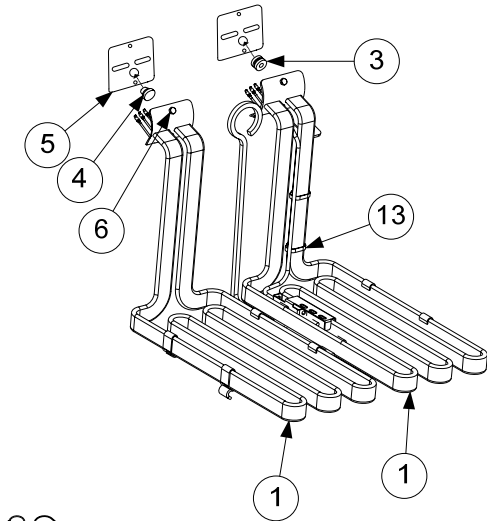

DUAL-VAT ELEMENT ASSEMBLY

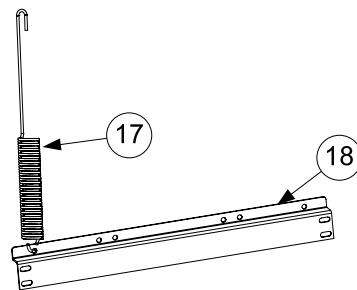
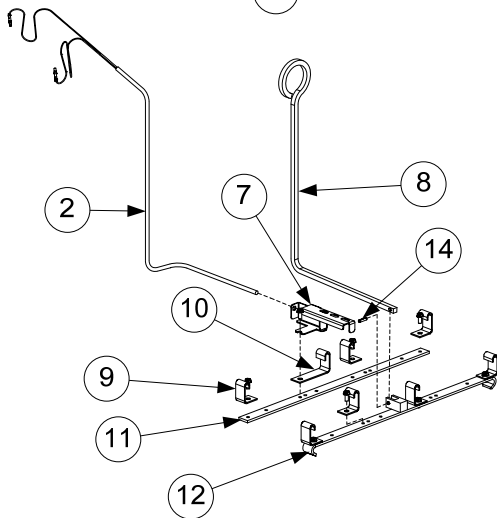
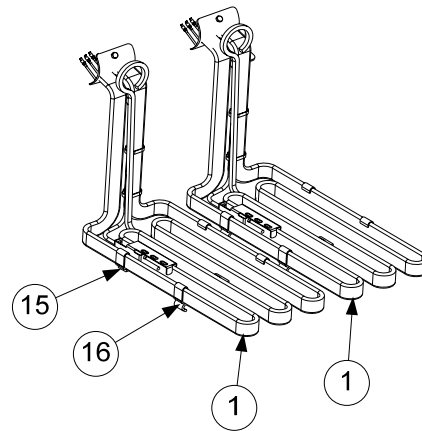

NOTES:

The dual-vat assembly is almost the same as the full-vat assembly except for having two of Items 2, 3, 7, 14, 15, 16 and 8. The only difference between element assemblies for different voltage and kW ratings is the element itself (Item 1).

Items 17 and 18 are shown as associated parts. They are not part of either assembly.

2.5.3.1 Heating Element Assemblies and Associated Parts cont.

ITEM	PART #	COMPONENT
1		Element Kits – <i>includes gaskets, grommets, tie wraps, screws and nuts.</i>
		1814 Elements
√	826-2557	208V 8.5 kW
√	826-2707	230V 8.5 kW
√	826-2558	240V 8.5 kW
	826-3020	480V 8.5kW
√	826-3014	208V 11.0 kW
√	826-3015	220V 11.0 kW
√	826-3016	230V 11.0 kW
√	826-3017	240V 11.0 kW
	826-3018	250V 11.0 kW
		RE Elements
√	826-2192	208V 7.0 kW
√	826-2197	208V 8.5 kW
√	826-2200	220V 7.0 kW
√	826-2198	220V 8.5 kW
√	826-2193	230V 7.0 kW
√	826-2199	230V 8.5 kW
√	826-2194	240V 7.0 kW
√	826-2200	240V 8.5 kW
√	826-2196	480V 7.0 kW
√	826-2203	480V 8.5 kW
√	2	826-2652 Probe, Temperature 1814 Kit – <i>includes tie wraps and grommet.</i>
		826-2212 Probe, Temperature RE Kit – <i>includes tie wraps and grommet.</i>
	3	816-0681 Grommet, Probe
	4	816-0480 Plug, .375-inch Dome
	5	816-0688 Gasket, Element
	6	809-1003 Screw, 10-32 X 3/8-inch Hex Head SS
	*	809-0766 Nut, 10-32 Keps Hex Head SS
	7	230-0784 Bracket, Temperature Probe (<i>use 230-3714 for RE DV</i>)
	8	810-1233 Handle, Element Lift
	9	910-2042 Clamp, Element (Short)
	10	230-0781 Clamp, Element (Long)
	11	230-4902 Support, Full-Vat Element Flat
	12	823-6711 Support, Full-Vat Element Front 1814 (<i>use 230-4304 for rear support not shown</i>)
		823-5621 Support, Full-Vat Element Front RE14/17
	13	809-0567 Tie-Wrap, Metal
	14	810-1212 Pin, .125 X .5-inch Split
	15	230-4903 Support, Dual-Vat Element Rear RE Dual Vat
	16	823-5624 Support, Dual-Vat Element Front Dual Vat RE14kW
		823-5627 Support, Dual-Vat Element Front Dual Vat RE17kW
	17	810-3030 Spring, Element Lift Left
		810-3031 Spring, Element Lift Right
	18	220-8402 Bracket, Lower Spring 1814 Filter, (<i>use 220-8297 RE Center, 220-8808 RE left, 220-8544 1814 non-filter</i>)

* Not illustrated.

√ Recommended parts.

2.5.3.2 Element Tube Assemblies

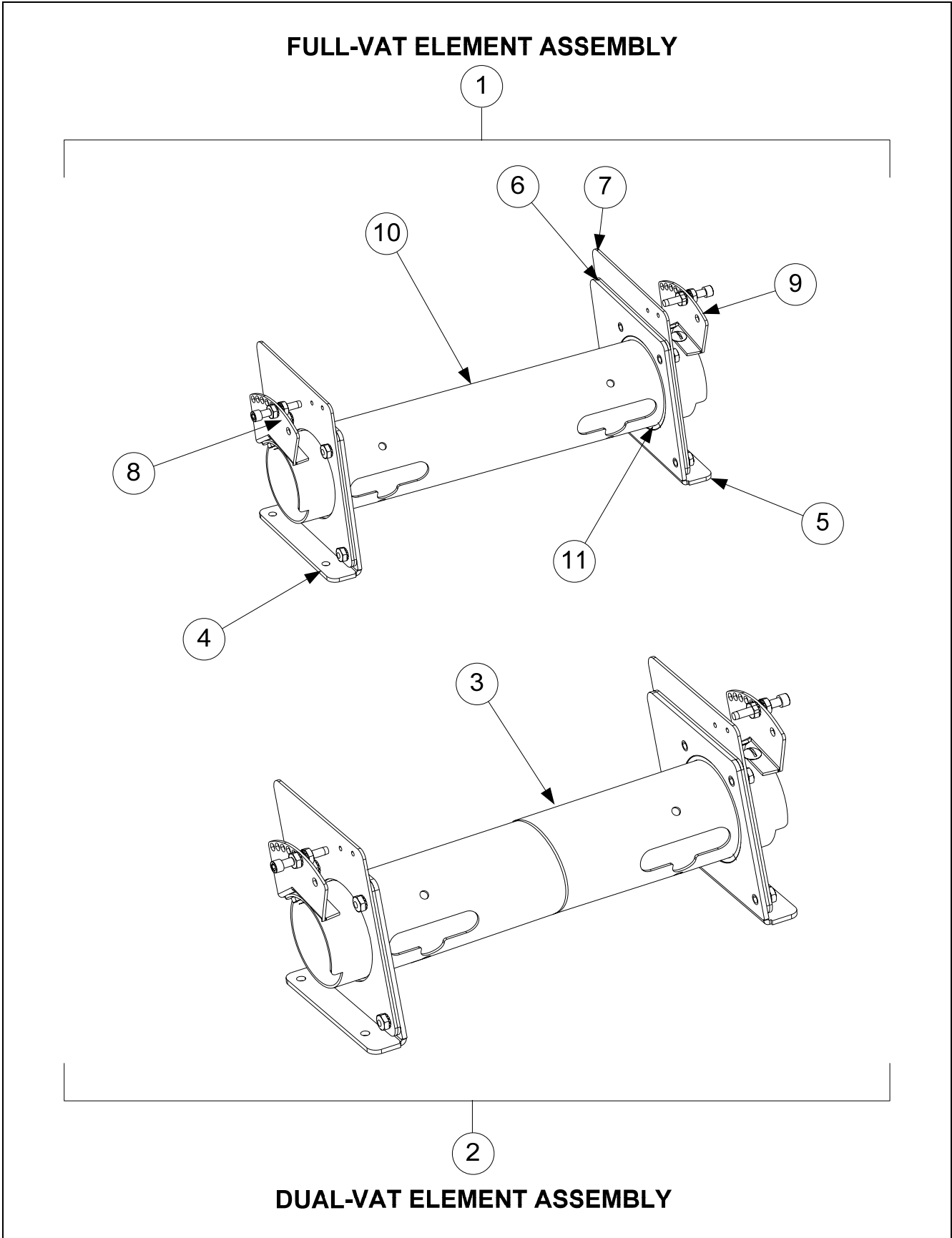

2.5.3.2 Element Tube Assemblies cont.

ITEM	PART #	COMPONENT
1	108-0293	Tube Assembly 1814/RE17kW Element, Full-Vat
	108-0297	Tube Assembly RE14kW Element, Full-Vat
2	108-0298SP	Tube Assembly RE14kW Element, Dual-Vat
	108-0295	Tube Assembly RE17kW Element, Dual-Vat
3	810-3246	Bushing and Tube Assembly, Dual-Vat
4	108-0315	Bracket Assembly, LH Element Tube Support
5	108-0316	Bracket Assembly, RH Element Tube Support
6	220-0122	Plate, Element Tube Support Inner
7	220-0123	Plate, Element Tube Support Outer
8	106-7651	Bracket Assembly, LH Upper Spring (<i>use 106-6569 for 17/22kW</i>)
9	106-7652	Bracket Assembly, RH Upper Spring (<i>use 106-6570 for 17/22kW</i>)
10	810-2992	Tube, FV Element Mounting
11	810-2993	Bushing, Tube End Teflon
*	809-0766	Nut, 10-32 Hex HD SS
*	826-2598	Kit, Tilt Switch
*	807-4742	Switch, Long Lever High Temp Tilt

* Not illustrated.

2.5.4 Controllers

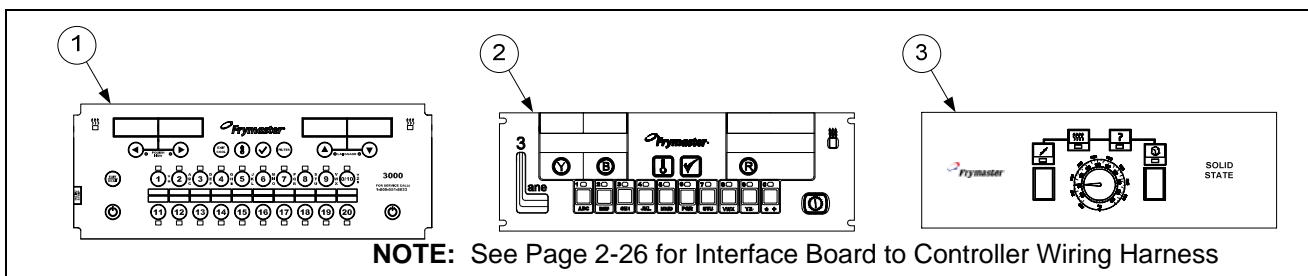

ITEM	PART #	COMPONENT
√ 1	108-2399SP	3000 Controller
√ 2	108-1351SP	3-Lane Controller
3		Solid-State (Analog) Controller
√	106-7987	Full-Vat
√	106-4334	Dual-Vat
*	802-2021	Graphic Sheet of Symbols

√ Recommended parts.

2.5.5 Wiring

2.5.5.1 Contactor Box Wiring Assemblies – 12-Pin Dual-Vat C-1

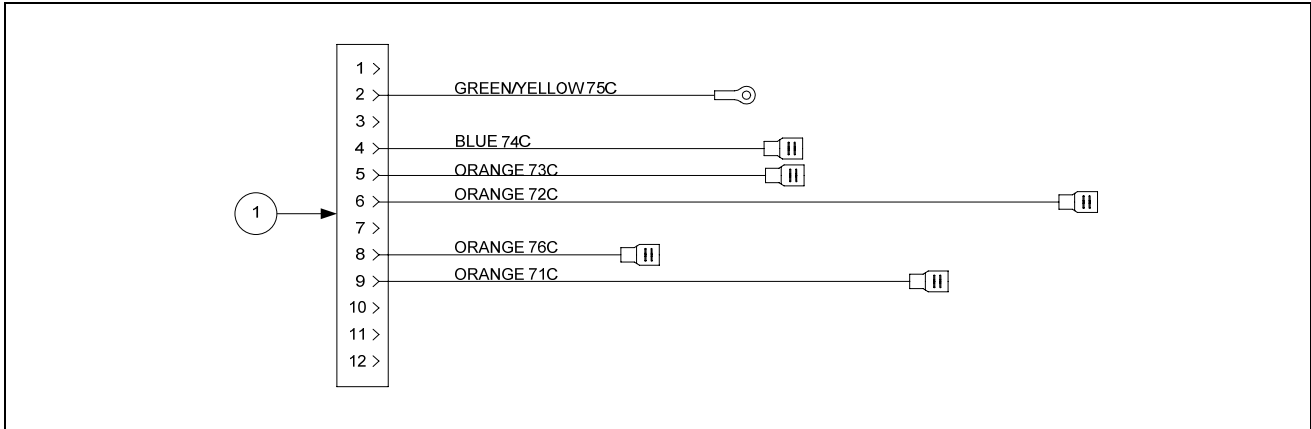

ITEM	PART #	COMPONENT
1	106-5980SP	Contactor Box Harness Assembly Dual Vat (uses harness plus wire kits) (See wiring diagrams on pages 1-19 and 1-20.)

2.5.5.2 Contactor Box Wiring Assemblies – 12-Pin Full-Vat C-1

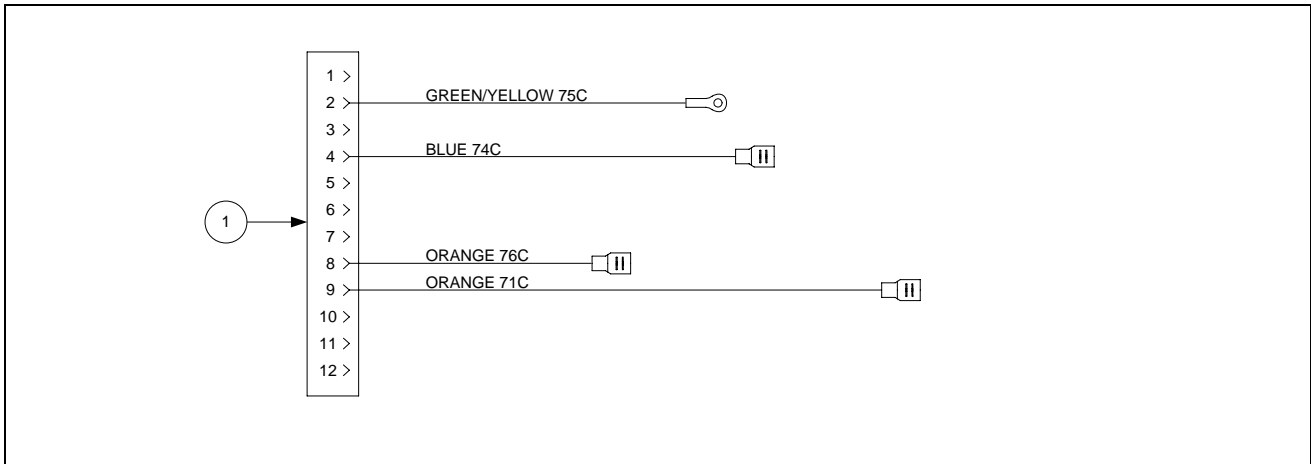

ITEM	PART #	COMPONENT
1	108-0159	Contactor Box Harness Assembly Full Vat (uses harness plus wire kits) (See wiring diagrams on pages 1-19 and 1-20.)

2.5.5.3 Contactor Box Wiring Assemblies – 6-Pin (Left Element)

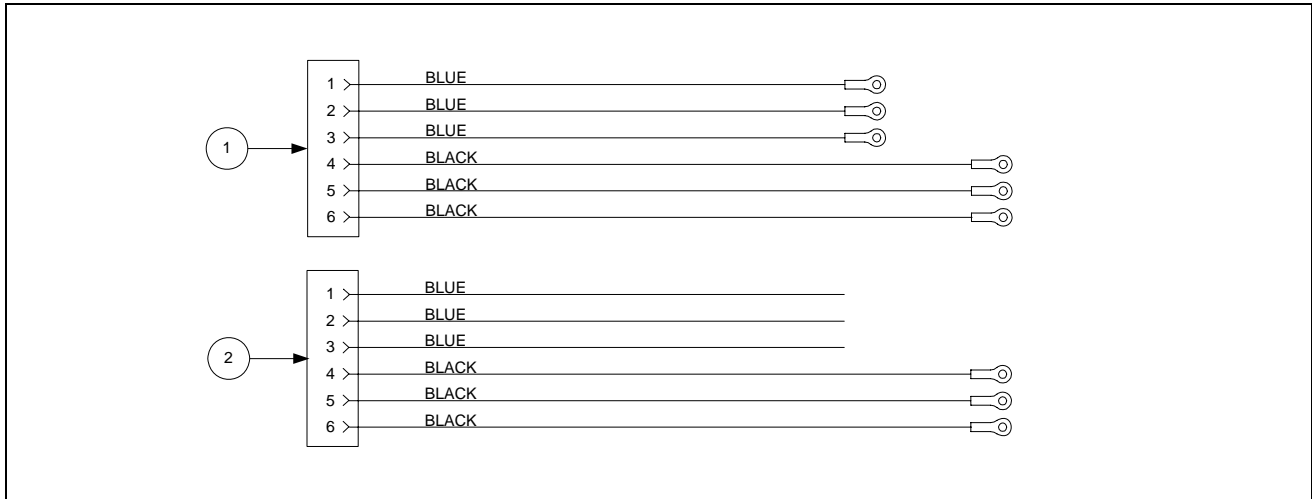

ITEM	PART #	COMPONENT
1	106-8742	14/17 kW SSR
	106-8747	22 kW SSR
2	106-8744	14/17 kW Mechanical Contactor MDI
	106-8749	22 kW High Amp Mechanical Contactor MDI

2.5.5.4 Contactor Box Wiring Assemblies – 9-Pin (Right Element)

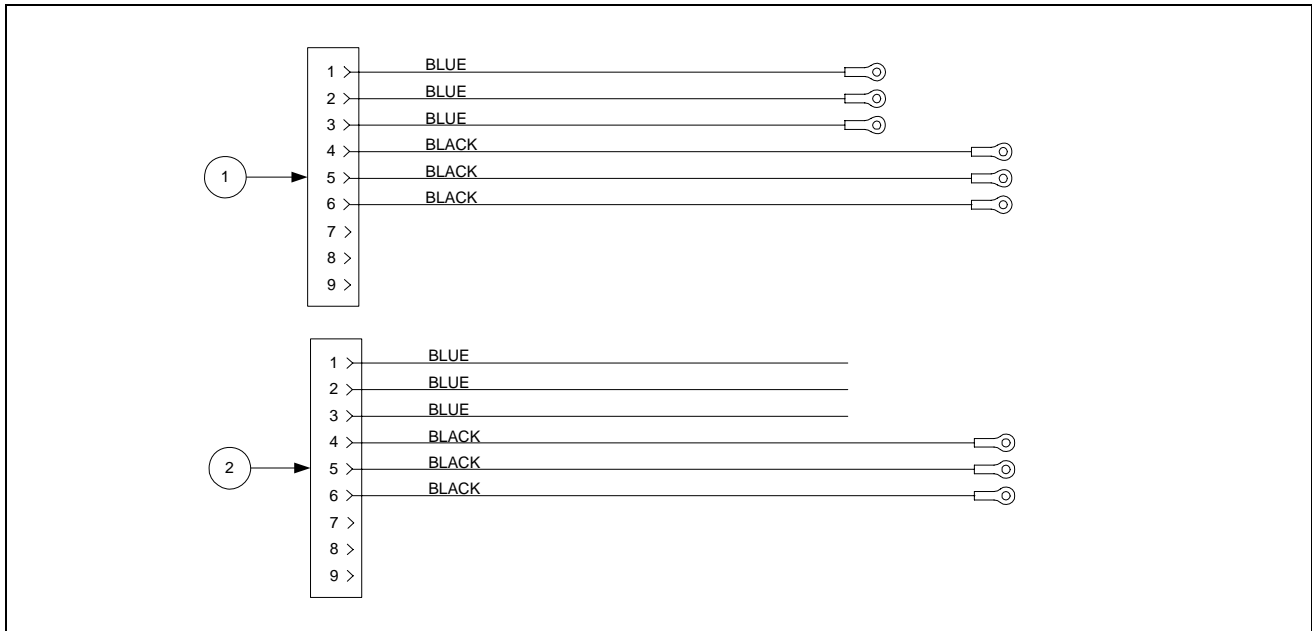

ITEM	PART #	COMPONENT
1	106-8743	14/17 kW SSR
	106-8748	22 kW SSR
2	106-8750	14/17 kW (22kW WYE & 22kW 480v) Mechanical Contactor
	106-8745	22 kW (17kW 480v) High Amp Mechanical Contactor

2.5.5.5 Main Wiring Harnesses - Full and Dual Vat

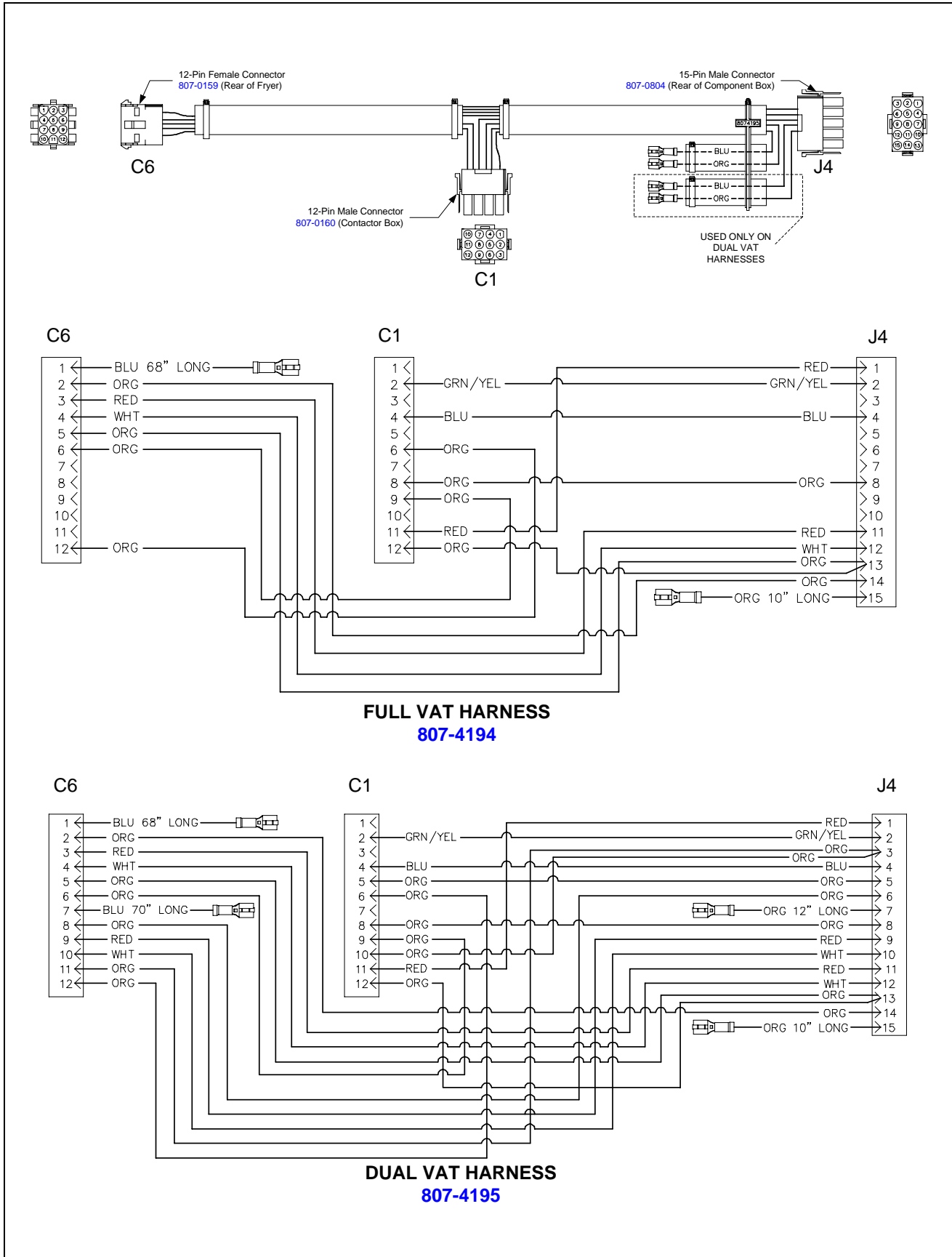

2.5.5.6 Component Box, Filter Pump and Basket Lift Wiring Harnesses

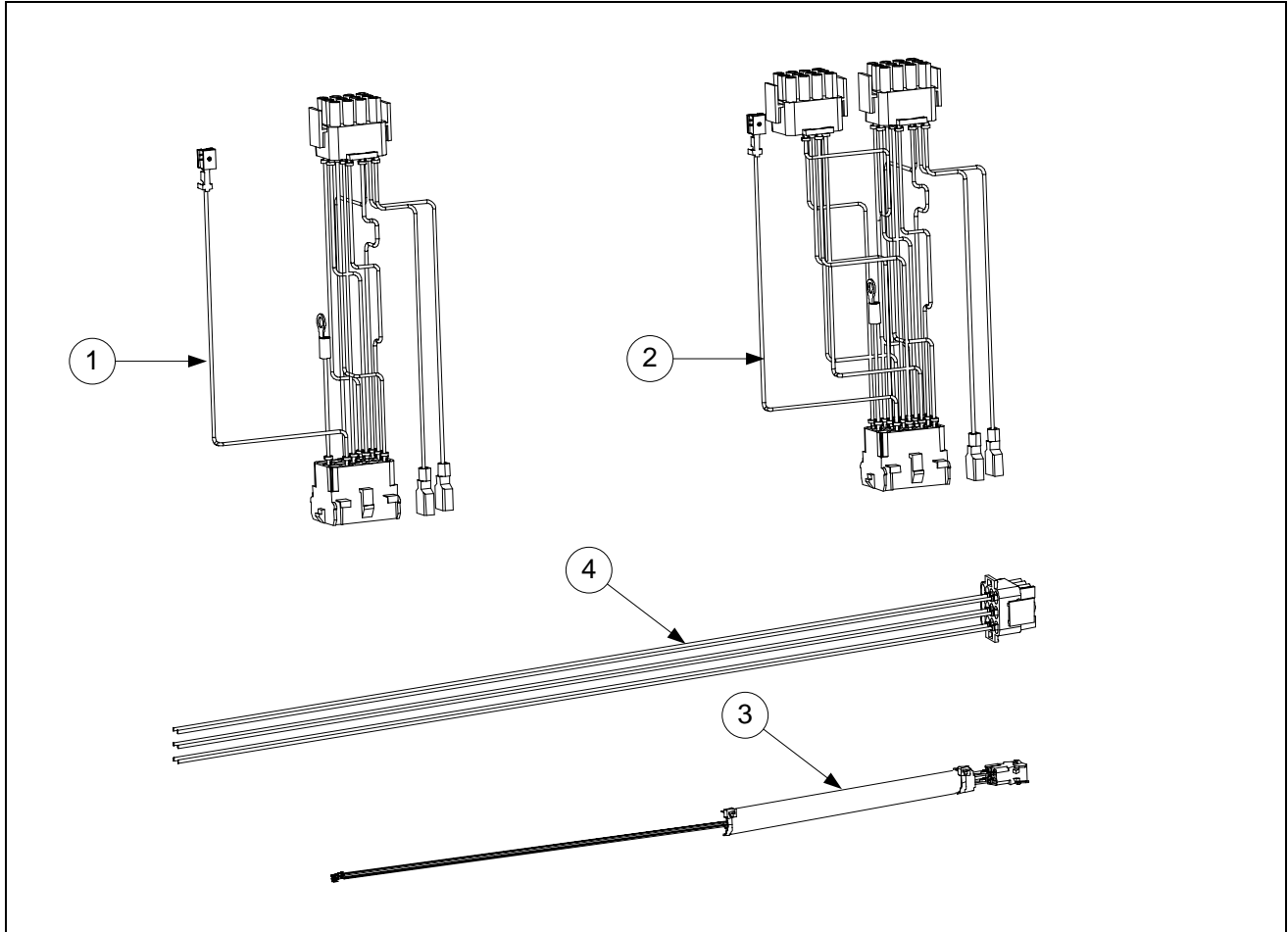

ITEM	PART #	COMPONENT
1	106-6639	Full Vat Control Harness J4 to J2 (<i>Solid State</i>)
2	106-6644	Dual Vat Control Harness J4 to J1 and J2 (<i>Solid State</i>)
3	106-5935SP	Filter Pump C2 to Component Box Wiring Harness
4	106-6640	Basket Lift Harness Assembly (<i>Solid State</i>)

2.5.5.7 Component Box to Filter Pump Harness

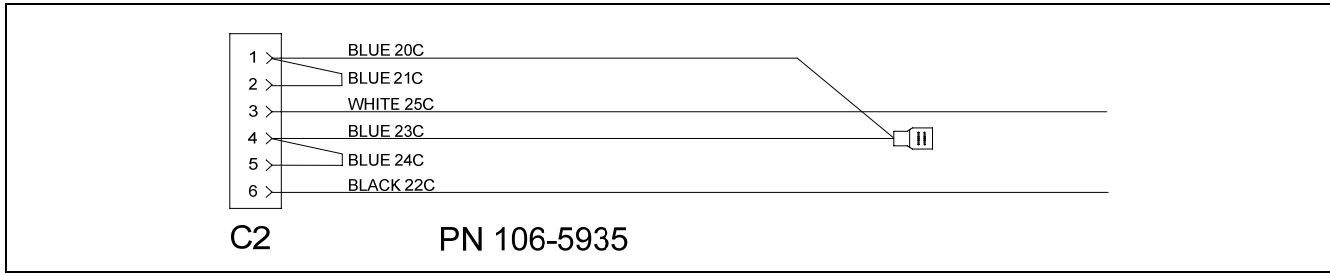

2.5.5.8 Basket Lift Harness

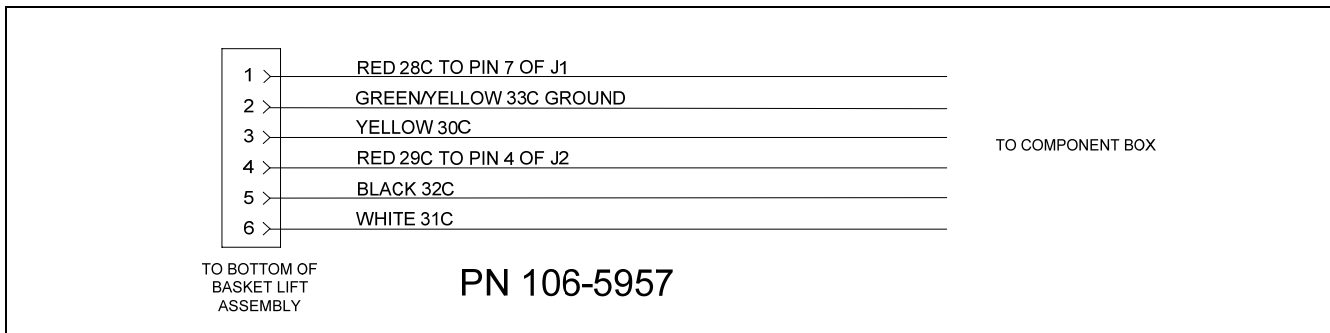

2.5.5.9 Interface Board to Controller Wiring Harnesses

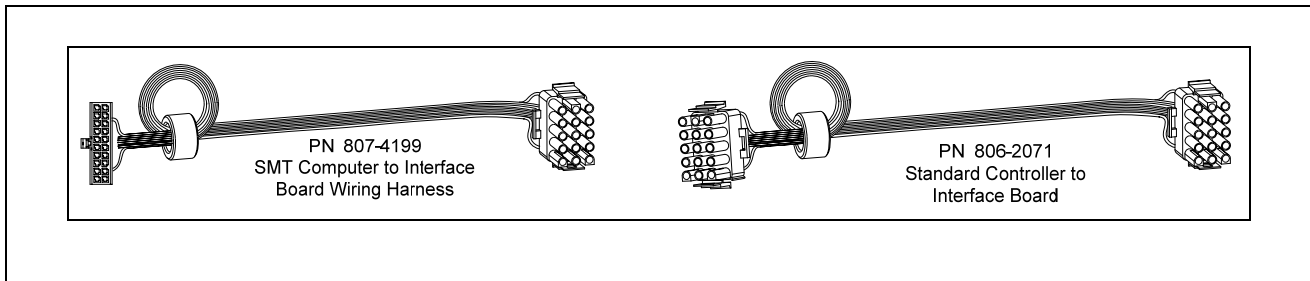

2.5.5.10 Drain Harnesses (3000)

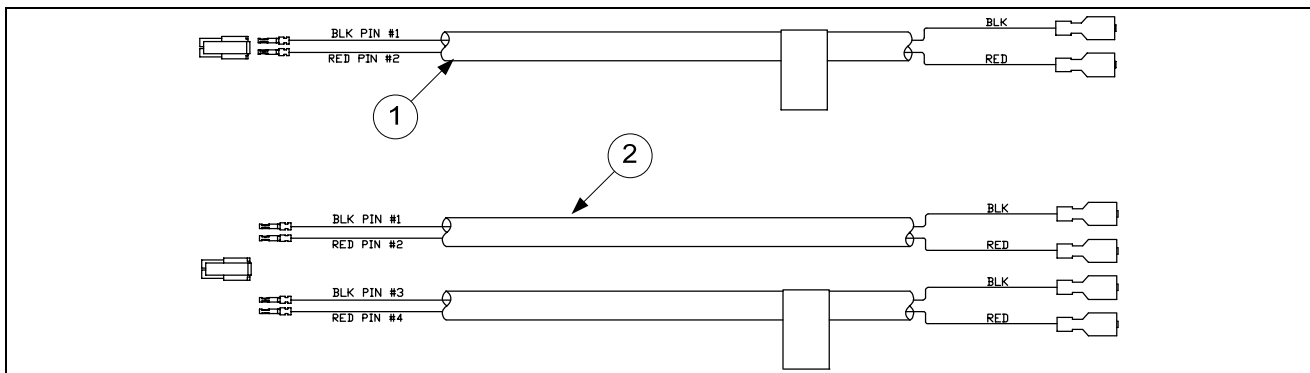

ITEM	PART #	COMPONENT
1	807-5159	Full Vat Drain Switch Harness
2	807-5160	Dual Vat Drain Switch Harness

2.6 Filtration System Components

2.6.1 Filter Pan Assembly

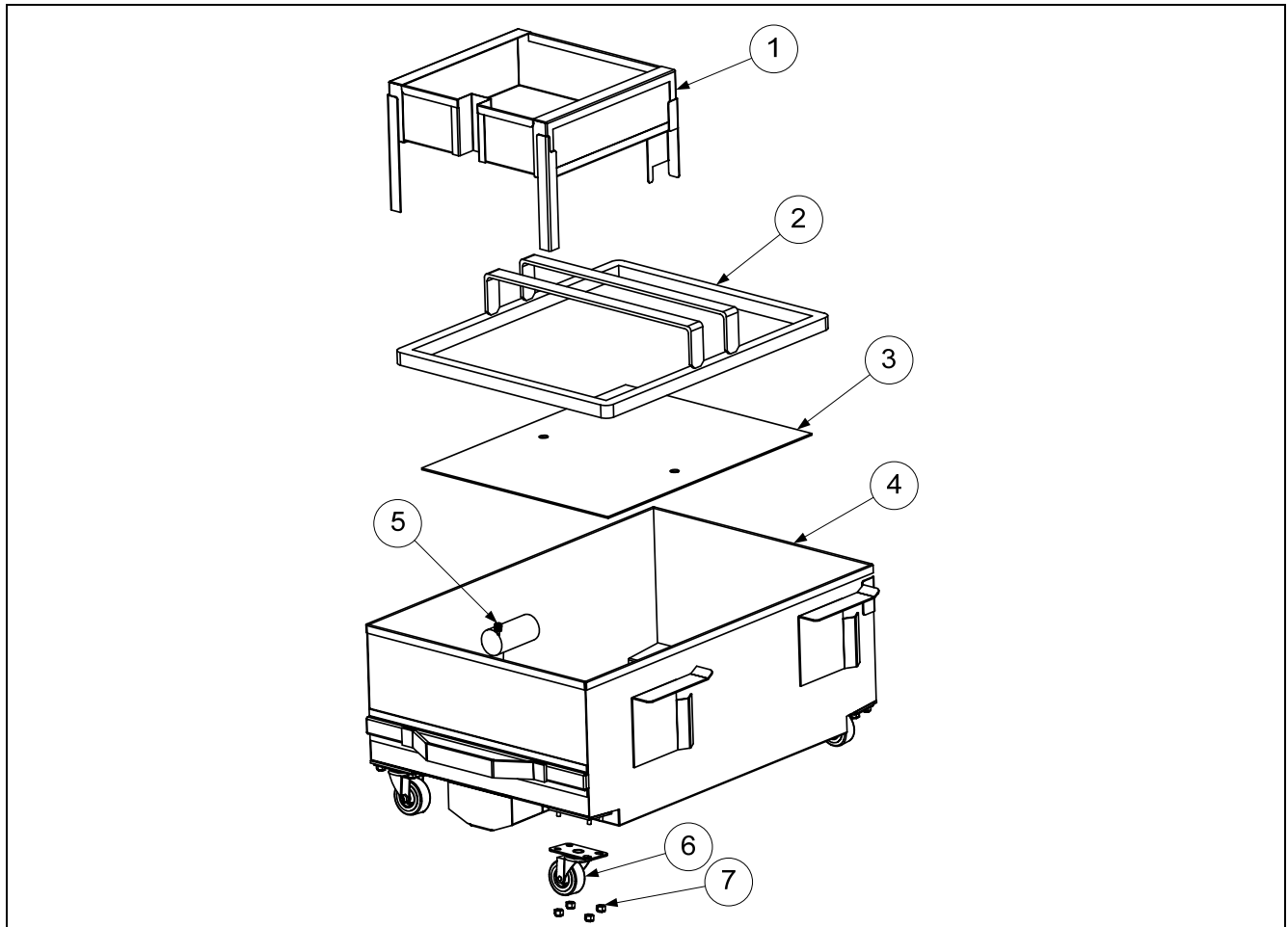

ITEM	PART #	COMPONENT
1	823-7425	Basket, Crumb
2	810-3541	Ring, Hold-down
3	200-8003	Screen, Sana Grid
4	823-7294	Pan, Filter
5	813-0568	Plug, 1/8" NPT Socket-Head Pipe
6	810-2805	Caster, 2" Filter Pan
7	809-0823	Nut, Nylock, 1/4-20
*	823-7418	Lid (mounted in frame)

* Not illustrated.

See page 2-1 for filter paper.

2.6.2 Filter Pump Motor Assembly

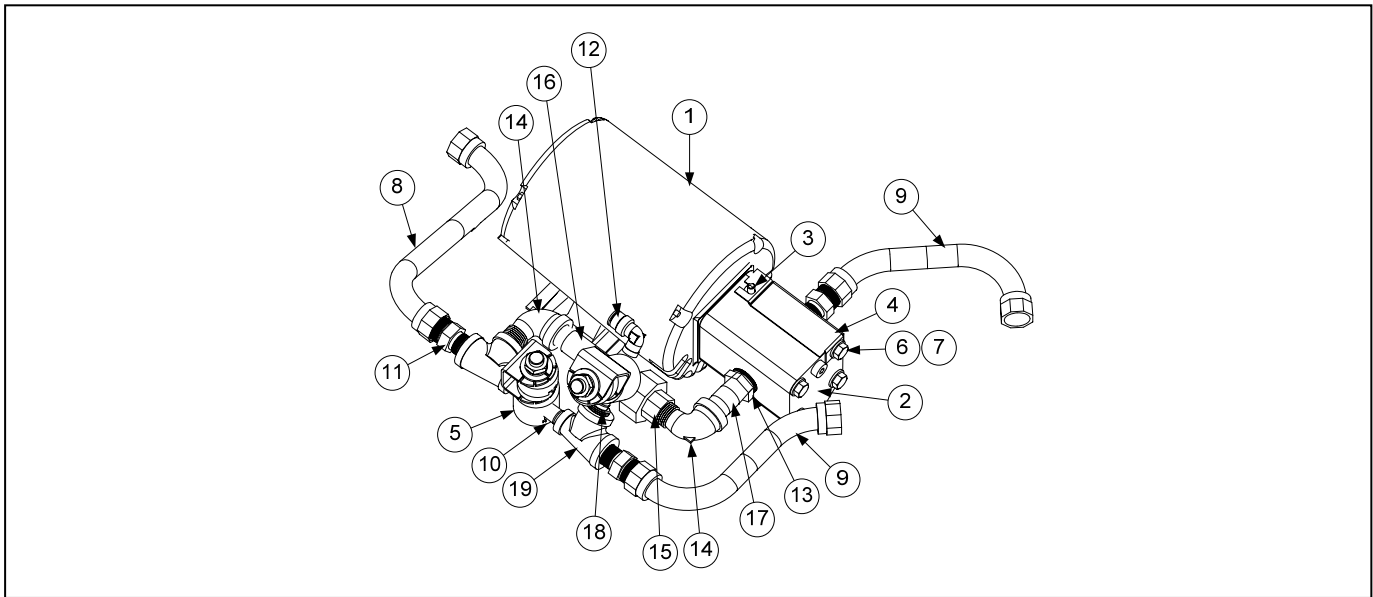

ITEM	PART #	COMPONENT
1		Motor and Gasket Kit
	826-1785	100V 50/60 Hz
√	826-1712	115V 50/60 Hz
√	826-1756	208V 50/60 Hz
	826-1270	220-240V 50/60 Hz
	826-1755	250V 50/60 Hz
√ 2	826-2796	Pump, Viking 8 GPM
√	810-3851	Pump, Viking 8 GPM with Heater Hole
	816-0093	Gasket, Pump/Motor
√ 3	108-2213	Heater Assy 120V 50W Cartridge
	108-2214	Heater Assy 240V 50W Cartridge
	108-2215	Heater Assy 24V 30W Cartridge
4	220-7927	Bracket, Filter Pump Mounting
√ 5	807-2484	Valve, 1/4-inch Solenoid
6	809-0194	Washer, Flat 5/16 SAE
7	809-1020	Cap Screw, 5/16-18
8	810-1057	Flexline, 5/8-inch x 13-inch
9	810-1067	Flexline, 5/8-inch x 8.50-inch
10	813-0838	Nipple, 1/4-inch Close
11	810-1668	Adapter, 5/8-inch to 1/2-inch NPT Male
12	810-3256	Fitting, 90° 1/4-inch NPT Male 3/8-inch OD Tube
13	813-0031	Bushing 3/4-inch NPT x 1/2-inch BM
14	813-0165	Elbow, ST 1/2-inch x 1/2-inch NPT 90° BM
15	813-0173	Union, 1/2-inch NPT BM
16	813-0247	Nipple, 1/2-inch x 3.50-inch NPT
17	813-0298	Nipple, 1/2-inch x 2.00-inch
18	813-0304	Bushing, 1/2-inch x 1/4-inch Flush
19	813-0530	Tee, Reducing 1/2-inch X 1/4-inch X 1/2-inch

* Not illustrated.

√ Recommended parts.

2.7 Frypot Assemblies and Associated Parts

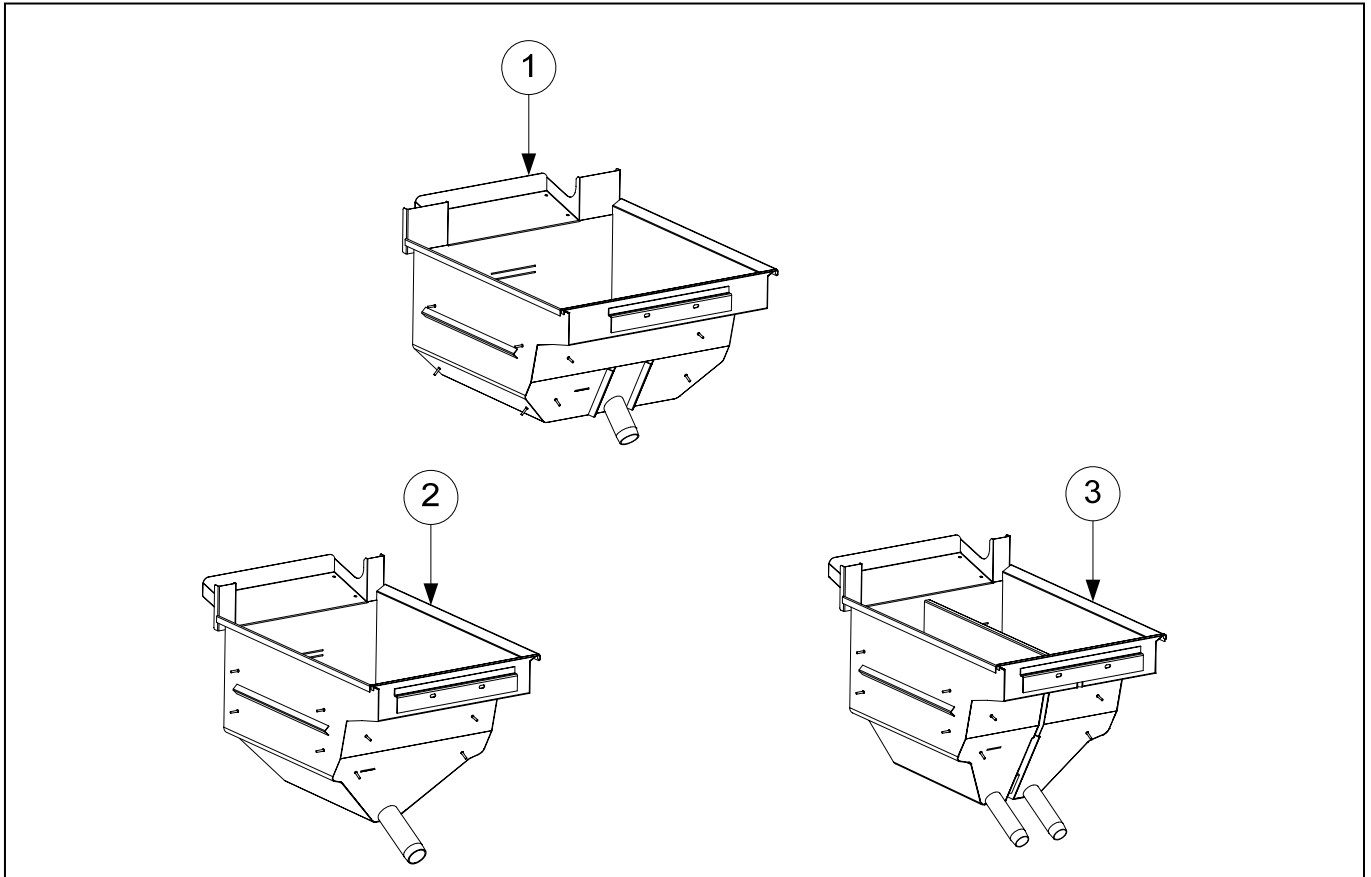

ITEM	PART #	COMPONENT
1	823-8067	Frypot, 1814E (<i>does not include insulation or thermostat</i>)
2	823-5545SP	Frypot, RE Full-Vat Filter with Insulation
3	823-5551SP	Frypot, RE Dual-Vat Filter with Insulation
√ *		Thermostat Assembly, High-Limit
	826-2454	Non-CE Full Vat 425°F (218°C) (17kW FV and 14kW FV)(Color-Coded Black 806-7543)
	826-2456	Non-CE Dual Vat 435°F (224°C) (22kW, 17kW DV and 14 kW DV) (Color-Coded Red 806-8035)
	826-2455	CE 415°F (213°C) (14kW and 17kW CE) (Color-Coded Yellow 806-8132)
	826-2457	CE 405°F (207°C) (22 kW FV and DV CE) (Color-Coded White 806-8536)
*	816-0899	Insulation, 1814 Side
*	816-0898	Insulation, 1814 Front/Rear
*	816-0773	Insulation, RE Kaowool 17½ -inch X 10-inch X ½-inch (4 required per pot)
*	220-8481	Retainer, Insulation 1814
*	900-4100	Retainer, Side Insulation RE
*	900-4101	Retainer, Front Insulation RE
*	900-1345	Retainer, Rear Insulation RE

* Not illustrated.

√ Recommended parts.

2.8 Oil Return System Components

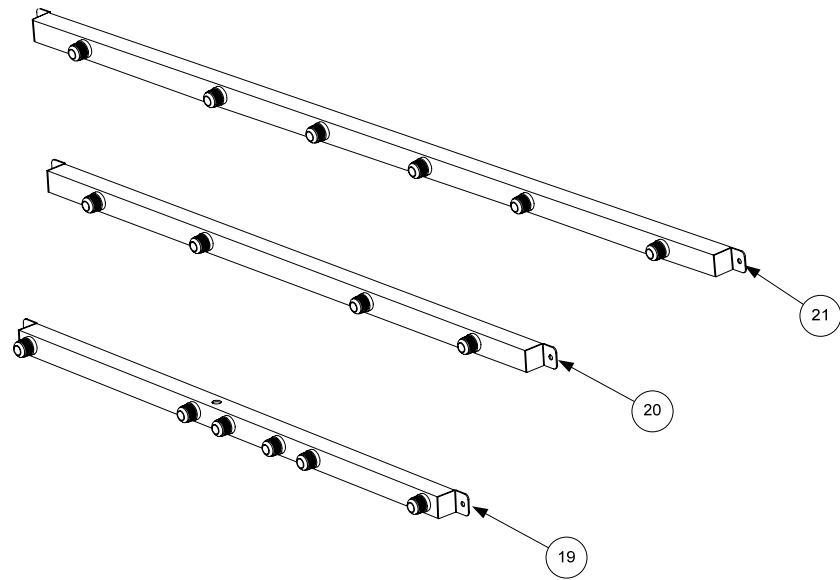

**Typical
Rear-Flush Oil Return
Plumbing**

Full-vat rear-flush plumbing is shown on the left side of the oil return manifold; dual-vat plumbing is shown on the right side. Plumbing for a two-fryer battery is illustrated, but all components except the oil return manifold are the same regardless of the number of fryers in the battery.

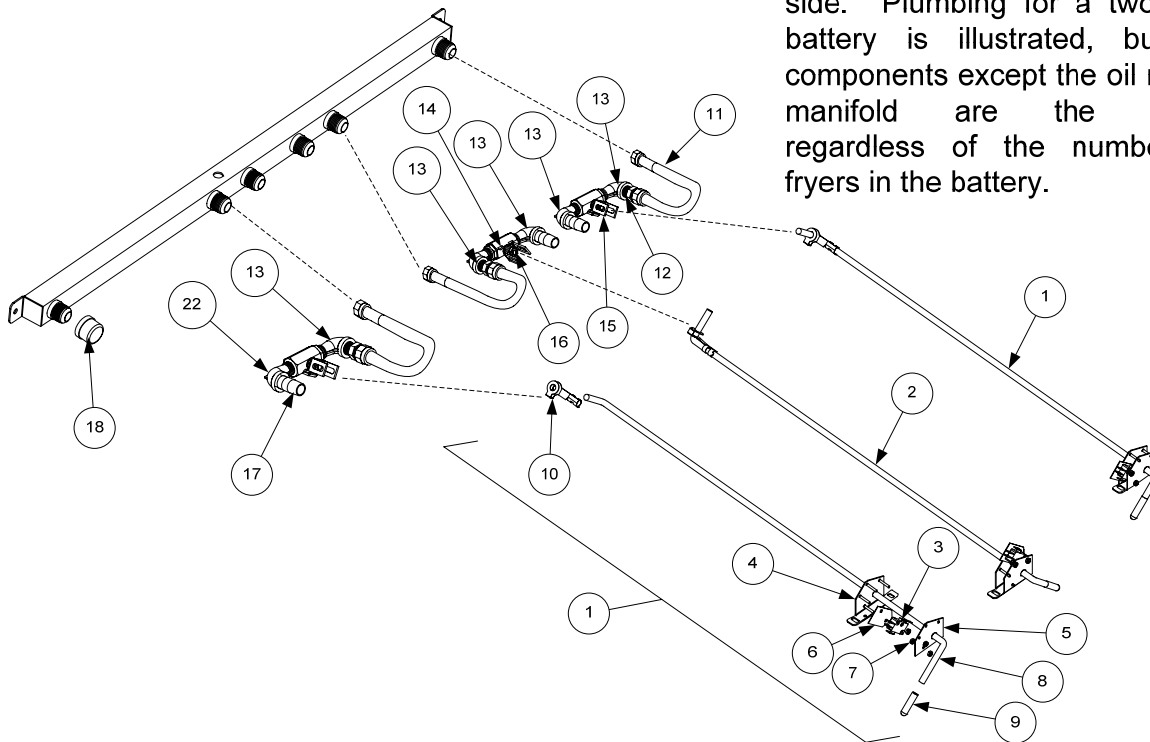

2.8 Oil Return System Components cont.

ITEM	PART #	COMPONENT
1	106-5596	Handle Assembly, Full-Vat and Right Dual-Vat Rear Flush Complete
	106-6410	Handle Assembly, Full-Vat Deep Cabinet Complete
2	106-5597	Handle Assembly, Left Dual-Vat Rear Flush Complete
3	807-4936	Microswitch, Straight Lever Gold Plated
4	106-5595	Bracket Assembly, Microswitch
5	200-5401	Bracket, Handle Retainer
6	816-0220	Insulation, Oil Return Microswitch
7	826-1366	Nut, 4-40 Keps Hex (Pkg. of 25)
8	810-3034	Rod, Full-Vat and Right Dual Vat Rear Flush RE
	810-3615	Rod, Rear Flush 1814E
	810-2533	Rod, Left Dual Vat Rear Flush
9	816-0643	Grip, Oil Return Valve Handle
10	809-0601	Clip, Clevis
11	810-2532	Flexline, 7.0-inch Multi-Vat Units
12	810-1668	Adapter, 5/8-inch to 1/2-inch NPT Male
13	813-0165	Elbow, 1/2-inch X 90° Street
14	810-0278	Valve, 1/2-inch Ball
15	220-4564	Handle, Rear Flush Valve 1814E
*	200-5438	Handle, Rear Flush Valve DV and FV RE
16	900-2935	Retainer, Oil Return Valve Nut
17	813-0460	Nipple, 1/2-inch X 3.0-inch NPT
18	813-0907	Cap, 15/16-inch Valve Safety
*	813-0463	Plug, Pipe 1/2-inch NPT
		Manifolds
19	810-3155	Manifold, Two-Station Fryer 1814E/RE or RE/1814E
20	810-3845	Manifold, Two-Station Fryer 2-1814
21	810-3875	Manifold, Three-Station Fryer 1814E/RE/1814E
22	813-0062	Elbow, 1/2-inch X 90° BM

* Not illustrated.

2.9 Wiring Connectors and Pin Connectors

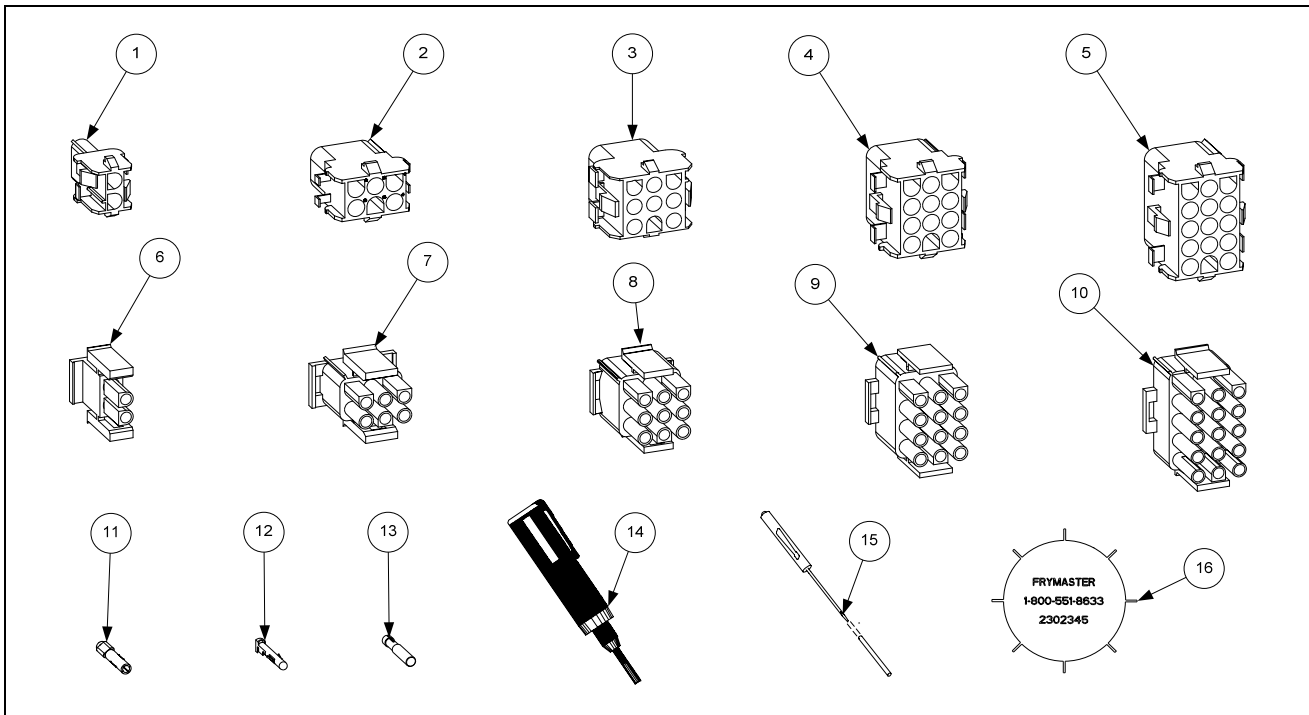

ITEM	PART #	COMPONENT
1	807-1068	2-Pin Female
2	807-0158	6-Pin Female
3	807-0156	9-Pin Female
4	807-0159	12-Pin Female
5	807-0875	15-Pin Female
6	807-1067	2-Pin Male
7	807-0157	6-Pin Male
8	807-0155	9-Pin Male
9	807-0160	12-Pin Male
10	807-0804	15-Pin Male
11	826-1341	Terminal, Female Split Pin (pkg. of 25)
12	826-1342	Terminal, Male Split Pin (pkg. of 25)
13	807-2518	Plug, Mate-N-Lock (Dummy Pin)
√ 14	807-0928	Extract Tool Pin Pusher
√ 15	806-4855	Pin Pusher Screwdriver Assembly
√ 16	230-2345	SMT Pin Extractor
√ *	807-4660PK	SMT Pin Service Repair Kit
*	807-3981	Cord (CE 17kW 230V-250V) requires 807-4797 strain relief and 220-6402 plate.
*	807-5272	Cordset, 3-Phase, 4 Wire 100A 250V with plug and strain relief.
*	807-3981	Cord (Non-CE Export 220V-380V) requires 807-4797 strain relief and 220-6402 plate.

* Not illustrated.

√ Recommended parts.

2.10 Fasteners

ITEM	PART #	COMPONENT
*	809-0429	Bolt, 1/4-inch – 20 x 2.00-inch Hex Head ZP Tap
*	809-0514	Capscrew, 5/16-inch-18 NC Hex
*	809-0448	Clip, Tinnerman
*	826-1366	Nut, 4-40 Keps Hex (Pkg. of 25) (809-0237)
*	826-1358	Nut, 6-32 Keps Hex (Pkg. of 25) (809-0049)
*	809-0247	Nut, 8-32 Keps Hex
*	826-1376	Nut, 10-32 Keps Hex (Pkg. of 10) (809-0256)
*	809-0766	Nut, 10-32 Keps Hex SS
*	809-0581	Nut, 1/2 NPT Locking
*	809-0020	Nut Cap 10-24 NP
*	826-1372	Nut Grip 1/4-inch 1/4-20 Hex NP (Pkg. of 10) (809-0059)
*	809-0417	Nut Flange 1/4-inch 1/4-20 Serr
*	809-0535	Nut, "T" 1/4-inch-20 x 7/16 SS
*	809-0540	Nut, Lock 1/2-inch-13 Hex 2-Way ZP
*	826-1359	Screw, 4-40 x 3/4-inch Slotted Round Head (Pkg. of 25) (809-0354)
*	826-1365	Screw, 6-32 x 3/8-inch Slot Head (Pkg. of 25) (809-0095)
*	809-0357	Screw, 6 x 3/8-inch Phillips Head NP
*	809-0359	Screw, 8 x 1/4-inch Hex Washer Head
*	809-0360	Screw, 8 x 3/8-inch Hex Washer Slot Head
*	826-1371	Screw, 8 x 1/2-inch Hex Head ZP (Pkg. of 25) (809-0361)
*	809-0364	Screw, 8 x 5/8-inch Hex Washer Head ZP
*	809-0518	Screw, 8-32 x 3/8-inch Hex Washer Slotted Head SS
*	809-0104	Screw, 8-32 x 1/2-inch Slotted Head ZP
*	826-1363	Screw, 8-32 x 1/2-inch NP (Pkg. of 25) (809-0103)
*	826-1360	Screw, 10-24 x 5/16-inch Round Slot Head ZP (Pkg. of 25) (809-0024)
*	826-1330	Screw, 10-32 x 3/8-inch Slot Head SS (809-0117)
*	809-1003	Screw, 10-32 x 3/8-inch Hex Trim Head SS
*	826-1375	Screw, 10-32 x 3/4-inch Hex Trim Head SS (Pkg. of 5) (809-0401)
*	809-1000	Screw, 10-32 x 1 1/4-inch Hex Sck C/S
*	826-1374	Screw, 10 x 1/2-inch Hex Head (Pkg. of 25) (809-0412)
*	809-0266	Screw, 10 x 1/2-inch Phillips Head ZP
*	809-0434	Screw, 10 x 3/8-inch Hex Washer Head NP
*	809-0123	Screw, 10 x 3/4-inch Slot Head
*	826-1389	Screw, 1/4-20 x 3/4-inch Hex Head ZP (Pkg. of 10) (809-0131)
*	809-0582	Washer 1/2 NPT Locking
*	809-0184	Washer, #10 LK ZP
*	809-0190	Washer, .625 X .275 X 40 Flat SS
*	809-0191	Washer, Lock 1/4 Spring ZP
*	809-0193	Washer, Flat 1/4 Nylon
*	809-0194	Washer, Flat 5/16 ZP

THIS PAGE INTENTIONALLY LEFT BLANK



Frymaster, L.L.C., 8700 Line Avenue, Shreveport, Louisiana 71106

TEL 1-318-865-1711

FAX (Parts) 1-318-219-7140

(Tech Support) 1-318-219-7135

PRINTED IN THE UNITED STATES

SERVICE HOTLINE
1-800-551-8633

819-6911
SEPTEMBER 2011