



LJS 24G Series Flatbottom  
Gas Fryers  
Installation & Operation Manual



Models 1824G, 2424G and 1824/2424G  
Systems with Built-In Filtration



Frymaster/Dean, a member of the Commercial Food Equipment Service Association, recommends using CFESA Certified Technicians.

24-Hour Service Hotline 1-800-551-8633

MARCH 2004

PRINTED IN THE USA

\* 8195758 \*

**Please read all sections of this manual and retain for future reference.**

This product has been certified as commercial cooking equipment and **MUST** be installed by professional personnel as specified. Installation, maintenance and repairs should be performed by your **FRYMASTER FACTORY AUTHORIZED SERVICE CENTER**.

 **DANGER**

Do not store or use gasoline or other flammable vapors and liquids in the vicinity of this or any other cooking appliance.

 **DANGER**

Instructions explaining procedures to be followed **MUST** be posted in a prominent location in the event the operator detects a gas leak. This information can be obtained from the local gas company or gas supplier.

 **WARNING**

Improper installation, adjustment, alteration, service or maintenance can cause property damage, injury or death. Read the installation, operating and maintenance instructions thoroughly before installing or servicing this equipment.

 **DANGER**

Safe and satisfactory operation of your equipment depends on proper installation. Installation **MUST** conform with local codes, or in absence of local codes, with the National Fuel Gas Code, ANSI Z223.1; The Natural Gas Installation Code, CAN/CGA-B149.1; The Propane Installation Code, CAN/CGA-B149.2; or The latest edition of the National Electric Code, N.F.P.A. 70.

**NOTICE**

IF, DURING THE WARRANTY PERIOD, THE CUSTOMER USES A PART FOR THIS ENODIS EQUIPMENT OTHER THAN AN UNMODIFIED NEW OR RECYCLED PART PURCHASED DIRECTLY FROM FRYMASTER/DEAN, OR ANY OF ITS AUTHORIZED SERVICE CENTERS, AND/OR THE PART BEING USED IS MODIFIED FROM ITS ORIGINAL CONFIGURATION, THIS WARRANTY WILL BE VOID. FURTHER, FRYMASTER/DEAN AND ITS AFFILIATES WILL NOT BE LIABLE FOR ANY CLAIMS, DAMAGES OR EXPENSES INCURRED BY THE CUSTOMER WHICH ARISE DIRECTLY OR INDIRECTLY, IN WHOLE OR IN PART, DUE TO THE INSTALLATION OF ANY MODIFIED PART AND/OR PART RECEIVED FROM AN UNAUTHORIZED SERVICE CENTER.

 **DANGER**

The crumb tray in fryers equipped with a filter system must be emptied into a fireproof container at the end of frying operations each day. Some food particles can spontaneously combust if left soaking in certain shortening material. Additional information can be obtained in the filtration manual included with the system.

**NOTICE**

The Commonwealth of Massachusetts requires any and all gas products to be installed by a licensed plumber or pipe fitter.

 **DANGER**

The front ledge of the fryer is not a step. Do not stand on the fryer. Serious injury can result from slips or contact with the hot oil.

 **WARNING**

Drawings and photos used in this manual are intended to illustrate operational, cleaning and technical procedures and may not conform to on-site management operational procedures.

 **WARNING**

No structural material on the fryer should be altered or removed to accommodate placement of the fryer under a hood. Questions? Call the Frymaster/Dean Service Hotline at 1-800-551-8633.

This equipment is to be installed in compliance with the basic plumbing code of The Building Officials and Code Administrators International, Inc. (BOCA) and the Food Service Sanitation Manual of the Food and Drug Administration.

**COMPUTERS**  
**FCC**

This device complies with Part 15 of the FCC rules. Operation is subject to the following two conditions:  
1) This device may not cause harmful interference, and 2) This device must accept any interference received, including interference that may cause undesired operation. While this device is a verified Class A device, it has been shown to meet the Class B limits.

**CANADA**

This digital apparatus does not exceed the Class A or B limits for radio noise emissions as set out by the ICES-003 standard of the Canadian Department of Communications.

Cet appareil numérique n'émet pas de bruits radioélectriques dépassant les limites de classe A et B prescrites dans la norme NMB-003 édictée par le Ministre des Communications du Canada.

 **DANGER**

**THIS PRODUCT CONTAINS CHEMICALS KNOWN TO THE STATE OF CALIFORNIA TO CAUSE CANCER AND/OR BIRTH DEFECTS OR OTHER REPRODUCTIVE HARM.**

Operation, installation, and servicing of this product could expose you to airborne particles of glasswool or ceramic fibers, crystalline silica, and/or carbon monoxide. Inhalation of airborne particles of glasswool or ceramic fibers is known to the State of California to cause cancer. Inhalation of carbon monoxide is known to the State of California to cause birth defects or other reproductive harm.

 **WARNING**

Do not bang fry baskets or other utensils on the fryer's joiner strip. The strip is present to seal the joint between the fry vessels. Banging fry baskets on the strip to dislodge shortening will distort the strip, adversely affecting its fit. It is designed for a tight fit and should only be removed for cleaning.

# LJS 24G Series Flatbottom Gas Fryers



## INSTALLATION & OPERATION MANUAL

### TABLE OF CONTENTS

	Page #
1. DESCRIPTION AND SPECIFICATIONS.....	1-1
2. PRE-INSTALLATION.....	2-1
3. INSTALLATION INSTRUCTIONS.....	3-1
4. INITIAL STARTUP.....	4-1
5. DAILY OPERATION.....	5-1
6. PREVENTATIVE MAINTENANCE.....	6-1
7. TROUBLESHOOTING.....	7-1

# LJS 24G SERIES FLATBOTTOM GAS FRYERS

## CHAPTER 1: DESCRIPTION AND SPECIFICATIONS

---

The LJS 24G Series gas fryers are energy-efficient, gas-fired units, design-certified by the American Gas Association and the National Sanitation Foundation, and manufactured to their basic performance and application specifications. All units are shipped completely assembled, with all accessories packed inside the frypot. All units are adjusted, tested, and inspected at the factory prior to crating for shipment.

### NOTE

**After uncrating, immediately inspect the equipment for visible signs of shipping damage. If such damage has occurred, do not refuse shipment, but contact the shipper and file the appropriate freight claims.**

## 1.1 OPERATING CONTROLS

Each unit is shipped with a solid-state electronic thermostat controller. The controller is mounted inside the cabinet. The controller contains an automatic melt cycle which activates the main burner "ON" for 4 seconds, then "OFF" for about 18 seconds, and is activated automatically every time the frypot shortening temperature is less than 150°F (66°C). The melt cycle is used to heat solid shortening properly.

Each unit is equipped with a control panel with two indicator lights and a power switch, reset switch and boil-out switch located in a control box inside the cabinet.

**Note: Systems built for KFC co-branded locations are not equipped with boil-out switches. Boil-out is not allowed in KFC co-branded locations.**

## 1.2 AUTOMATIC SAFETY FEATURES

LJS 24G Series gas fryers come equipped with the following features:

- A. High oil-temperature detection to shut off gas to the main burners through the solenoid-actuated gas valve.
- B. Combination gas valve includes built-in pressure regulator.
- C. Sail switch (air prover) built into outlet duct shuts off power to the burners in the event of blower failure.
- D. Drain valve safety switch prohibits burner ignition if the valve is not completely closed.



**DANGER**

**ALL FRYERS MUST BE CONNECTED ONLY TO THE TYPE OF GAS IDENTIFIED ON THE RATING PLATE!**

### 1.3 RATING PLATE

The rating plate can be found inside the fryer door. Information on this plate includes the model and serial numbers, as well as BTU/hr output of the burners, outlet gas pressure in inches W.C., and configuration: natural or propane gas. Rating plate data is essential for proper unit identification, communicating with the factory or requesting special parts and/or information.

### 1.4 SERVICE PROBLEMS

Call 1-800-551-8633 for the location of your nearest Factory Authorized Service Center. Always have the model and serial numbers of your filter and fryer ready for when you speak to a representative. A parts list is included in Chapter 8 of this manual. Customers may order parts directly from their local Factory Authorized Service Center. Call 1-800-551-8633 for the location of your nearest Factory Authorized Service Center. Factory address and phone numbers are on the rear cover of this manual.

### 1.5 AFTER PURCHASE

In order to improve service, have the following chart filled in by the Frymaster Authorized Service Technician who installed this equipment.

Authorized Service Technician/FASC	_____
Address	_____
_____	_____
Telephone/Fax	_____
Model Number	_____
Serial Number	_____
Gas Type	_____

### 1.6 ORDERING PARTS

Customers may order parts directly from their local factory authorized service center. For this address and phone number, contact your factory authorized service center or call the Frymaster/Dean Service Hotline phone number, 1-800-551-8633.

To speed up your order, provide the model number, serial number, gas type, part needed, item part number (if known), and quantity needed.

## 1.7 COMPUTER INFORMATION

This equipment has been tested and found to comply with the limits for a Class A digital device, pursuant to Part 15 of the FCC rules. While this device is a verified Class A device, it has been shown to meet the Class B limits. These limits are designed to provide reasonable protection against harmful interference when the equipment is operated in a commercial environment. This equipment generates, uses and can radiate radio frequency energy and, if not installed and used in accordance with the instruction manual, may cause harmful interference to radio communications. Operation of the equipment in a residential area is likely to cause harmful interference in which case the user will be required to correct the interference at their own expense.

The user is cautioned that any changes or modifications not expressly approved by the party responsible for compliance could void the user's authority to operate the equipment.

If necessary, the user should consult the dealer or an experienced radio and television technician for additional suggestions.

The user may find the following booklet prepared by the Federal Communications Commission helpful: "How to Identify and Resolve Radio-TV Interference Problems". This booklet is available from the U.S. Government Printing Office, Washington, DC 20402, Stock No. 004-000-00345-4.

## 1.8 SAFETY INFORMATION

Before attempting to operate your unit, read the instructions in this manual thoroughly.

Throughout this manual, you will find notations enclosed in double-bordered boxes similar to the ones below.

### CAUTION

**CAUTION** boxes contain information about actions or conditions that *may cause or result in a malfunction of your system*.

### WARNING

**WARNING** boxes contain information about actions or conditions that *may cause or result in damage to your system*, and which may cause your system to malfunction.

### DANGER

**DANGER** boxes contain information about actions or conditions that *may cause or result in injury to personnel*, and which may cause damage to your system and/or cause your system to malfunction.

## 1.9 SERVICE PERSONNEL

### 1.9.1 Definitions

#### A. Qualified and/or Authorized Operating Personnel

1. Qualified/authorized operating personnel are those who have carefully read the information in this manual and have familiarized themselves with the equipment functions, or have had previous experience with the operation of equipment covered in this manual.

#### B. Qualified Installation Personnel

1. Qualified installation personnel are individuals, or firms, corporations, or companies, which, either in person or through a representative are engaged in and are responsible for the installation of gas-fired appliances. Qualified personnel must be experienced in such work, be familiar with all gas precautions involved, and have complied with all requirements of applicable national and local codes.

#### C. Qualified Service Personnel

1. Qualified service personnel are those who are familiar with Frymaster/Dean equipment and have been authorized by Frymaster/Dean to perform service on Frymaster/Dean equipment. All authorized service personnel are required to be equipped with a complete set of service parts manuals and stock a minimum amount of parts for Frymaster/Dean equipment. A list of Frymaster/Dean Factory Authorized Service Centers (FASCs) was included with the fryer when shipped from the factory. ***Failure to use qualified service personnel will void the Frymaster/Dean warranty on your equipment.***

# LJS 24G SERIES FLATBOTTOM GAS FRYERS

## CHAPTER 2: PRE-INSTALLATION

---

### 2.1 GENERAL

- A. Installation of any gas-fired equipment should be performed by qualified personnel.
- B. A manual gas shut-off valve must be installed in the gas supply line between the appliance(s) and the main gas supply for safety and ease of future service.

### 2.2 CLEARANCES

The appliance area must be kept clear of all combustibles. Each unit is design-certified for the following installations:

1. Commercial use only (not for household use).
2. For installation on a combustible floor when equipped with the factory supplied 5" casters (6" work height).
3. Areas with a minimum clearance of 6" side, 6" rear and 6" from the floor for combustible construction. LJS 24G Series flatbottom gas fryers must be installed with the casters provided. Locking casters should be installed on the front (cook side) of the fryer.

### 2.3 STANDARDS

Installation must be accomplished in accordance with all applicable state and local codes, with special attention to the following standards:

- A. The fryer and its individual shut-off valve must be disconnected from the gas supply piping system during any pressure testing of that system at pressures in excess of 1/2 PSI.
- B. The fryer must be isolated from the gas supply piping system by closing its individual manual shut-off valve during any pressure testing of the gas supply piping system as pressures equal to or less than 1/2 PSI.
- C. National Fuel Gas Code  
ANSI Z-223.1-1988 (or latest edition)  
American Gas Association  
1515 Wilson Boulevard  
Arlington, VA 22209
- D. National Electrical Code  
ANSI/NFPA #70-1984 (or latest edition)  
American National Standards Institute  
1430 Broadway  
New York, NY 10018

## 2.3 STANDARDS (cont.)

- E. NFPA Standards #96 and #211 (latest edition)  
National Fire Protection Association  
470 Atlantic Avenue  
Boston, MA 02110



### **WARNING**

**Local building codes will usually not permit a deep fat fryer with an open tank of hot oil to be installed immediately next to an open flame of any type, whether a broiler or the open burner of a range. Check local codes before beginning installation.**

## 2.4 AIR SUPPLY & VENTILATION

The area around the appliance must be kept clear to avoid airflow obstruction of combustion and ventilation air as well as for ease of maintenance and service. Never use the interior of the fryer cabinet for storage.

- A. Means must be provided for any commercial, heavy-duty cooking appliance to exhaust combustion wastes to the outside of the building. It is essential that a deep fat fryer be located under an approved exhaust hood or that an exhaust fan be provided in the wall above the unit, as exhaust gas temperatures are in the vicinity of 450°F-600°F (232-343°C).

Exhaust hoods and air conditioning systems can produce slight air drafts in the room, which can interfere with pilot or burner performance. Air movement patterns should be defined during installation. If pilot or burner problems arise or persist, alteration of air movement patterns will be required.

- B. Do not place the flue outlet of the fryer directly into the plenum of the hood; fryer gas combustion will be affected.
- C. Exhaust temperatures, in addition to the open tank of hot oil, make the storage of anything on shelving over or behind the fryer unsafe.
- D. Filters and drip troughs should be part of any industrial hood. Consult local codes before installing an industrial hood.

## 2.5 ALTITUDE

The input rating (BTU/hr) of LJS 24G Series fryers is rated for elevations up to 2,000 feet (610 Meters). For elevations above 2,000 feet (610 Meters), the rating should be reduced four percent for each additional 1,000 feet (305 Meters) above sea level.

# LJS 24G SERIES FLATBOTTOM GAS FRYERS

## CHAPTER 3: INSTALLATION INSTRUCTIONS

---

### 3.1 UNPACKING

Check that the container is upright. Use outward prying - **no hammering** - to remove the carton. Inspect the fryer(s) for visible damage. If such damage has occurred, do not refuse shipment, but contact the carrier and file the appropriate freight claims.

**FRYMASTER/DEAN FRYERS EQUIPPED WITH LEGS ARE FOR PERMANENT INSTALLATION. FOR MOVEABLE OR PORTABLE INSTALLATION, FRYMASTER/DEAN OPTIONAL EQUIPMENT CASTERS MUST BE USED. QUESTIONS? CALL 1-800-551-8633.**

### 3.2 CASTERS

Casters should be installed near where the appliance is to be used. After unpacking, raise the unit approximately 12 inches to attach casters to the couplings. Lower the fryer gently to prevent damaging the casters and internal mounting hardware. Use a pallet lift jack if available, when installing casters. Systems ordered with optional casters come with casters installed.

### 3.3 POSITIONING

Do not push against any of the edges of the unit to adjust its position. Lift fryer slightly and place it where it is to be installed. Although all metal parts are deburred during manufacture, accidents could occur if the fryer (or a lineup) should move suddenly when being pushed into position by hand. Pushing a unit (rather than using a lift jack) also increases the probability of bending the leg spindles or the internal coupling connectors.

### 3.4 LEVELING

- A. A spirit level should be placed across the top of the fryer and the unit leveled both front-to-back and side-to-side (side-to-side adjustment is not possible on units equipped with casters). Erratic burner combustion, inefficient unit operation and oil-drainage problems are some of the problems caused by unlevelled fryers. In addition, units may not match up properly in a multi-unit battery.
- B. If the floor is smooth and level, minor height adjustments can be made with the screw adjustment on each leg. Adjust to the high corner and measure with the spirit level. Fryers equipped with casters have no level adjustment options. The floor area where caster-equipped units are installed must be level.

## 3.5 GAS CONNECTION

The gas supply (service) line must be the same size or greater than the inlet line of the appliance. LJS 24G Series gas fryers use a 3/4" NPT (Schedule 40) inlet; however, the gas supply lines must be sized to accommodate all the gas-fired equipment that may be connected to that supply.

Consult your contractor, gas company or supplier, or other authorized agent for inspection and installation. Sealant on all pipe joints must be resistant to LP gas.

### 3.5.1 Manual Shut-off Valve

The manual shut-off valve must be installed in the gas service line ahead of the appliance in the gas stream and in a position where it can be reached quickly in the event of an emergency.

### 3.5.2 Gas Pressure Regulation

All commercial cooking equipment must have a pressure regulator on the incoming service line for safe and efficient operation, since service pressure may fluctuate with local demand. External regulators are not required on LJS 24G Series gas fryers as the pilot safety control valve regulates gas pressure. If the incoming pressure is in excess of 1/2" PSI (3.45 kPa), a step-down regulator will be required.

Check burner manifold pressure with a manometer. Natural gas units require 4" W.C. gas pressure and propane (LP) units require 11" W.C. gas pressure. If a pressure regulator vent line is installed, it should be vented to the outside of the building in accordance with local codes, or ANSI Z223.1 (or current revision).

Disconnect the fryer/individual shut-off valve from the main gas supply when pressure testing systems in excess of 1/2" PSI (3.45 kPa). When pressure-testing systems equal to or less than 1/2" PSI (3.45 kPa), isolate the fryer by closing the manual control valve prior to testing.

### 3.5.3 Gas Valve/Orifice Configuration

LJS 24G Series gas fryers can be connected to either natural or propane gas, depending on the configuration. The safety control valve and orifices are installed at the factory for the appropriate gas. If the gas valve and/or orifices require adjustment or conversion in the field, only authorized service personnel with proper test equipment should make the adjustments or conversion.

### 3.5.4 Rigid Connections

LJS 24G Series gas fryers come as single units or in multi-unit batteries. Inspect all installer-supplied gas-intake pipe(s) for dirt, metal dust and other foreign material. Use compressed air to clear foreign material from supply piping before installing into a service line. Failure to do this can result in clogged orifices and gas valve damage when gas pressure is applied.

All connections must be sealed with a joint compound suitable for LP gas, and all connections must be tested with a soapy solution before lighting any pilots. **DO NOT USE AN OPEN FLAME TO CHECK FOR LEAKS!** Detecting gas leaks with an open flame is not only dangerous, but will often miss small leaks that a soapy solution would detect.

### 3.5.5 Flexible Couplings, Connectors

If the unit is to be installed with flexible couplings and/or quick-disconnect fittings, the installer must use a heavy-duty, AGA design-certified commercial flexible connector. The connector must be at least 3/4" NPT (with suitable strain reliefs) in compliance with the Standard for Connectors for Movable Gas Appliances, ANSI Z21.69-1987 (or latest edition). Quick-disconnect devices must comply with the Standard for Quick-Disconnect Devices for Use with Gas Fuel, ANSI Z21.41-1989 (or latest edition). DOMESTIC CONNECTORS ARE NOT SUITABLE!

If multi-unit batteries are installed on casters, the same ANSI Standards apply. In addition, some means must be provided to limit the movement of the appliances without depending on the connectors or associated piping.

### 3.6 ELECTRICAL CONNECTIONS

The wiring diagram is attached to the inside of the fryer door. Wiring diagrams are also included in this manual for reference. Always consult the wiring diagram mounted on the fryer when troubleshooting or repairing the fryer. LJS 24G Series gas fryers require 120 volts, and are equipped with a 16-3 SJT grounded flexible power cord for direct connection to a 120-volt power supply. Amperage for each unit depends on the accessories supplied with the unit.



**WARNING**  
**(Electrical Grounding Instructions)**

**This appliance is equipped with a three-prong (grounding) plug for your protection against shock hazard, and should be plugged directly into a properly grounded three-prong receptacle. Do not cut, remove, or otherwise bypass the grounding prong on this plug!**

### 3.7 SYSTEM INSTALLATION INSTRUCTIONS

1. This system consists of a 2424G fryer with a built-in filter and an additional fryer that will be attached to it. The additional fryer may be a 24G, an 1824G or a 2424G. If the additional fryer is an 1824G, the 18-inch frypot must be in the outside position, as shown in the illustration below.

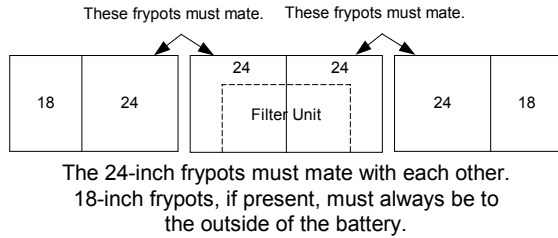

Figure 1. Retainer latches securing filter pan.

2. Prior to removing the fryers from their pallets, open the doors of the 2424G with the filter and unlatch the filter pan locks (Fig. 1, circles). Disconnect the filter supply hose and remove the filter pan from the cabinet. Remove the fryers from the pallets by lifting them up and over the pallet supports. Avoid damage to the casters and caster support bases when lifting and placing fryers.

All connection hardware (bolts, nuts, etc.) is included in the shipping bag.

3. Remove the upper and lower back panels (Fig. 2, arrows) of the cabinets to be joined. Set the screws and back panels aside for later reassembly.
4. Position the cabinets within 6 inches of each other, close to the area where they will be installed. Do not push the cabinets together at this time. Connect the red and yellow wires exiting the cabinets to be joined (Fig. 3). The 1824G oil-return switches will not work if these wires are not connected.
5. The fryer with the filter has a slip-nut attached to its drain-tee. Lubricate its O-rings with vegetable oil. The fryer to be attached has a drainpipe running from its drain-tee through a hole in the cabinet side. This drainpipe will be inserted into the slip-nut in the next step.



Figure 2. Removing cabinet backs to access connection points.

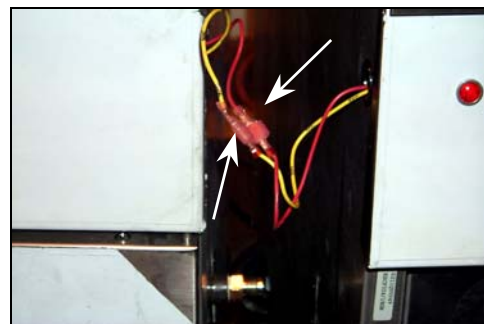

Figure 3. Yellow and red wires connecting oil return switches.

### 3.7 SYSTEM INSTALLATION INSTRUCTIONS (CONT.)

6. Slowly push the two systems together. Adjust the front casters to align the cabinets vertically. Ensure the drainpipe and the slip-nut (lower set of arrows in Fig. 4) are aligned and that the drain-flush lines (upper set of arrows in Fig. 4) are aligned. Also ensure the oil-return line flange and fittings on the rear of the fryer are aligned. Connect the fittings, but do not tighten the connections. Feed the yellow and red wire connections evenly through each cabinet wire hole as the cabinets are pushed together. Ensure the wire connections go inside the wireway, and are not pinched between the cabinets.
7. With the cabinets together, carefully slide the drainpipe into the slip-nut as far as it will go. Shine a flashlight down the drain of the fryer with the filter and slowly pull the drainpipe back out of the slip-nut until its end can no longer be seen. Tighten the slip-nut hand tight. Connect the drain-flush and oil-return lines (Fig. 5, circle), but do not tighten the connections. Align the cabinet connection holes, front and back (Fig. 5, arrows). Insert bolts and install nuts loosely. Do not tighten bolts at this time.
8. When the two cabinets are properly aligned, tighten the cabinet connection nuts and bolts and at the front and back. **At the fryer front:** Tighten the drainpipe slip-nut and tighten the drain-flush line flare-nut (do not over-tighten). **At the fryer back:** Tighten the oil-return line flare-nut (do not over-tighten).
9. Reinstall back panels removed at the beginning of system assembly. Ensure panels are properly aligned, then install and tighten the screws. Install the joiner strip where fryer cabinets are connected.
10. Connect the oil-return heater-tape harness (6-pin connector) at the bottom back of the fryer (Fig. 6, arrows). Failure to do so will result in clogged return lines after the first filtering session.



Figure 4. Drainpipe and drain-flush fitting alignment and connection points.



Figure 5. Rear cabinet connection holes. Note oil return line fittings.

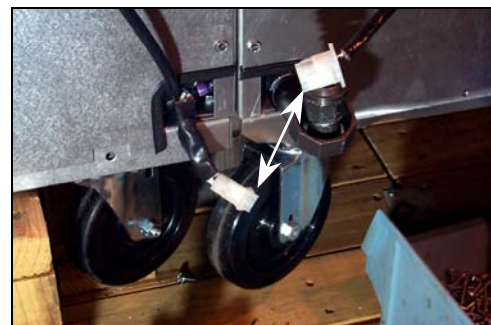
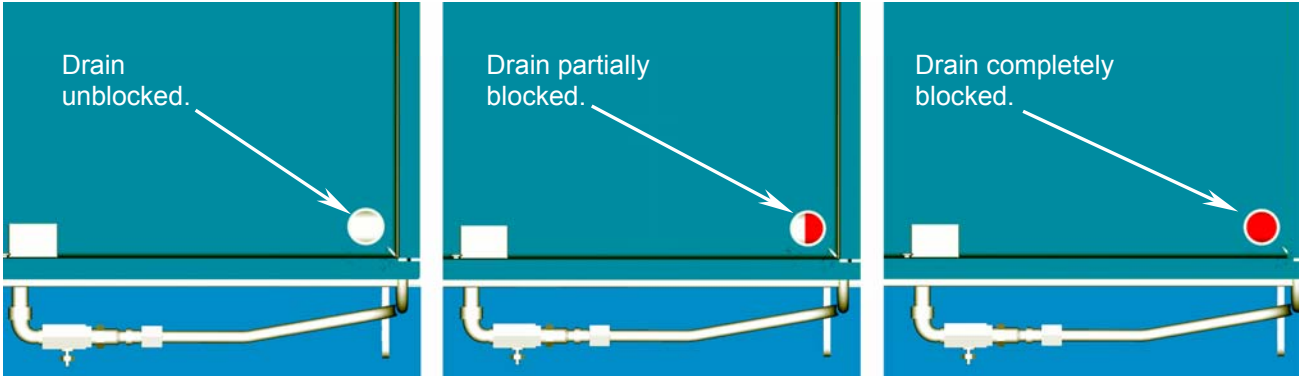

Figure 5. Connect oil-return line heater-tape connectors.

### 3.7 SYSTEM INSTALLATION INSTRUCTIONS (CONT.)

11. Prior to performing start-up, ensure the drainpipe connected during assembly is not blocking either frypot drain. Shine a flashlight into the drains. The illustration below shows from left to right, an unblocked drain, a partially blocked drain, and a completely blocked drain. If partially or completely blocked, loosen the drain slip-nuts and reposition the drain tube. Both drains should appear as the left-most picture below.



12. Reinstall filter system after fryer start-up has been performed (boil-out, burner adjustment, etc.) **NEVER ALLOW WATER OR BOILOUT SOLUTION INTO FILTER SYSTEM.**

13. Follow the filtration instructions for the UFF filter and return the oil to each of the fryers in the system. Check the oil return and drain lines for leaks. After the filtration system check is complete, discard the oil and filter paper (if a filter screen is used, thoroughly wash the assembly, dry completely and return to the pan). The frying system is ready for operation.

14. If the unit is supplied with an Over-The-Fryer Crumb Dump, install in accordance with the illustration below.

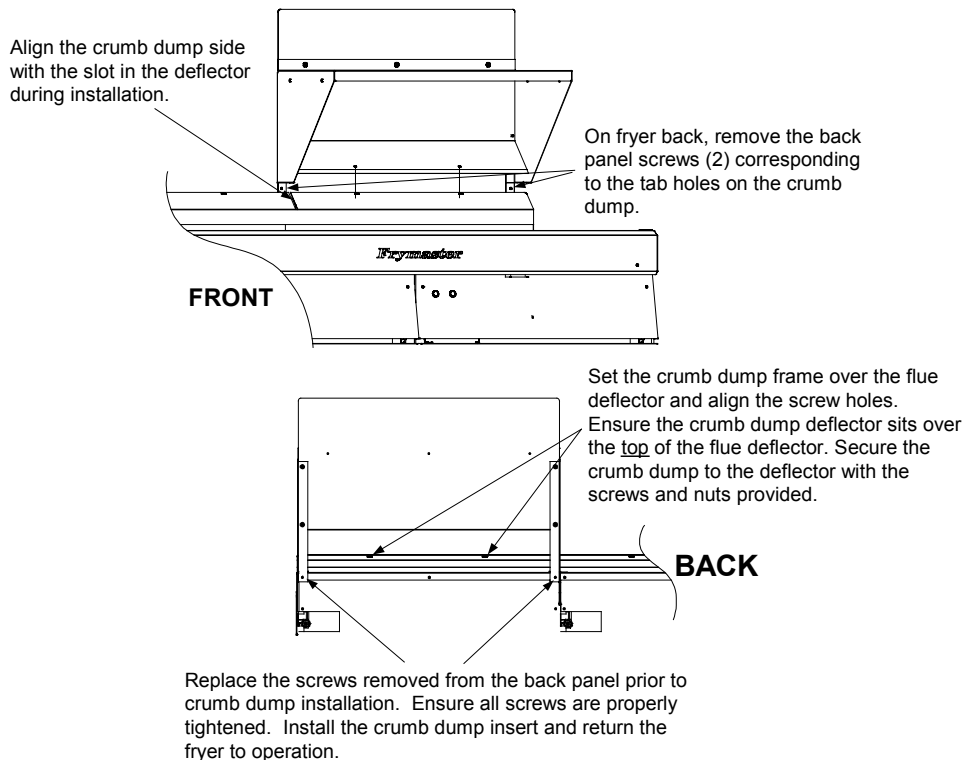

# LJS 24G SERIES FLATBOTTOM GAS FRYERS

## CHAPTER 4: STARTUP AND OPERATING PROCEDURES

### 4.1 CLEANING

**Note:** All procedures should be performed as instructed in the current LJS Operations Manual. In the absence of the LJS Operations Manual, the following procedures are offered as a temporary solution.

New units are wiped clean with solvents at the factory to remove dirt, oil, and grease remaining after the manufacturing process, and then coated with light oil. Prior to first use, boil out the frypot (remove temperature sensor guard prior to cleaning frypot) as outlined in Section 4.4.1, Boil-Out Procedure. (In KFC co-branded locations, **do not boil out the fryer.** Use the KFC-approved procedure for cleaning the frypot.) Wash any accessories shipped with the unit in hot, soapy water to remove remaining residue. Rinse the frying utensils with a solution of vinegar and water (1 pint vinegar to 1/2 gallon of hot water) to neutralize any soap residue, then rinse with clean water and thoroughly dry all surfaces.

**NOTE:** In KFC co-branded locations, boil out is **NOT ALLOWED.** Use KFC approved procedure.

Ensure the sensor probe guard is replaced after cleaning to protect the sensor probe and high-limit probe (Figure 1).

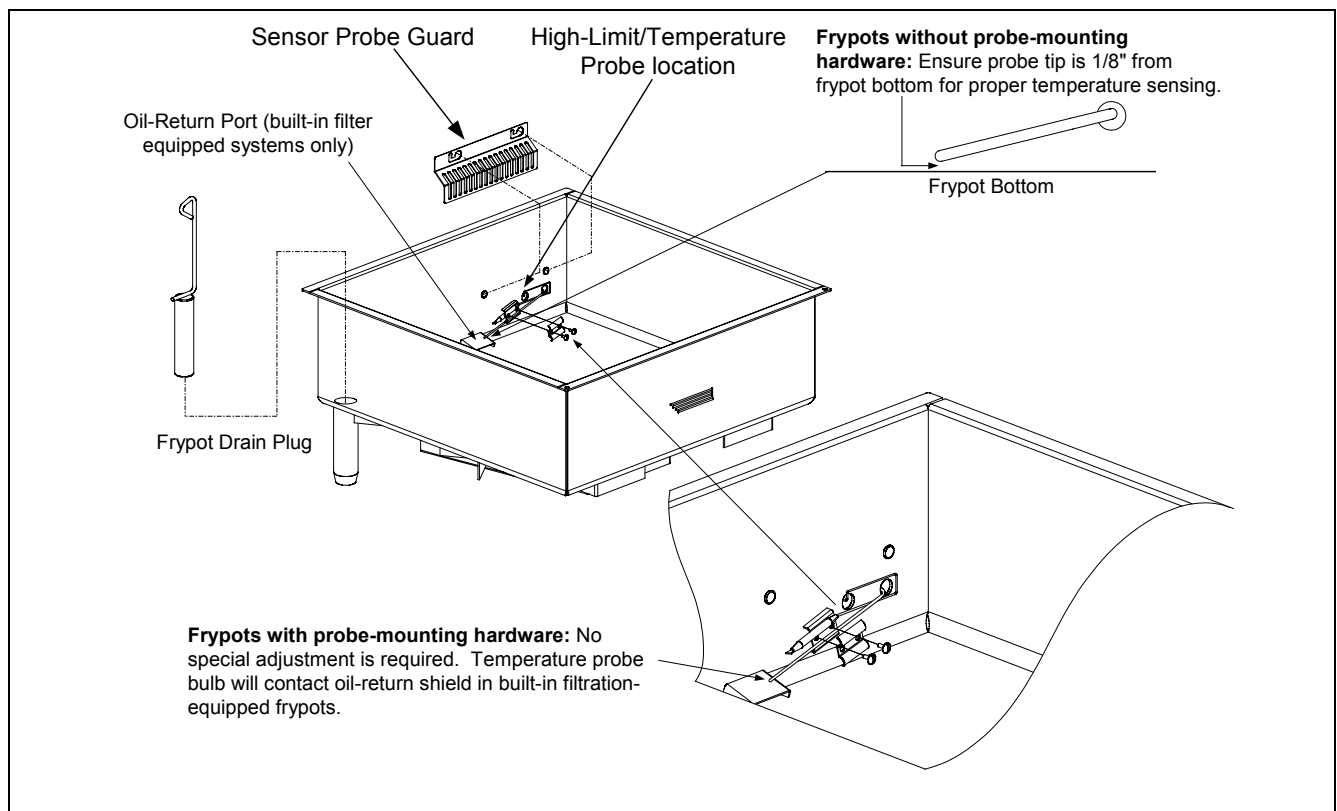

Figure 1: Sensor probe guard, frypot drain plug and high-limit/sensor probe location.

## 4.2 INITIAL STARTUP

LJS 24G Series gas fryers are tested, adjusted, and calibrated before leaving the factory. Adjustments to assure proper operation may be necessary upon installation to meet local conditions, low gas pressure, differences in altitude, variations in gas characteristics and to correct possible problems caused by rough handling or vibrations during shipment. Gas component adjustments after receiving the fryer should be performed by authorized service personnel.

Gas component adjustments are the responsibility of the customer and/or dealer and are not covered by the Frymaster/Dean warranty.



### CAUTION

**IF THE MAIN BURNERS ARE OPERATED WITH THE FRYPOT EMPTY, THE FRYPOT WILL BE DAMAGED.**

**IF THE FRYPOT IS DAMAGED DUE TO INCORRECT OPERATION, SUCH AS HEATING AN EMPTY FRYPOT OR WHOLE BLOCKS OF SHORTENING, ALL APPLICABLE WARRANTIES WILL BE VOIDED.**

**NOTE: In KFC co-branded locations do not use water for initial startup. Use shortening or oil only.**

#### Pilot Light or re-light procedure:

1. Turn the manual shut-off valve "OFF" on the incoming service line.
2. Turn the Thermatron dial to the lowest setting.
3. Turn the gas valve dial to "OFF" and wait 5 minutes before lighting pilot.
4. Fill the frypot with oil or water (for testing). Fill to the appropriate oil level line scribed in the back of the frypot (see store operational procedures for appropriate fill level).

**NOTE: In KFC co-branded locations, oil must be used in place of water for burner testing.**

5. Open the manual shut-off valve on the incoming service line.
6. Apply a lit match or taper to the pilot burner orifice.
7. Turn the gas valve dial to "PILOT". Depress and hold until the pilot stays lit (approximately 1 minute).
8. Turn the Thermatron controller to any "ON" setting and ensure the main burners ignite from the pilot.

### 4.3 ELECTRONIC SPARK IGNITION



**WARNING**  
**NEVER USE A MATCH OR TAPER TO LIGHT THIS IGNITION SYSTEM!**

1. Turn off the electric power.
2. Turn the gas valve dial to "OFF", wait 5 minutes, and then turn the dial to "ON".
3. Set the thermostat to the desired temperature. If the frypot is filled with water (**Non-KFC co-branded locations**), set thermostat to 200°F (93°C); if filled with oil, set thermostat to 350°F (177°C).
4. Turn the fryer power switch on.
5. The blower motor should start and the fryer should light a few seconds later. After burner ignition, the Thermatron controller controls the burner.
6. If the burner fails to light for whatever reason, a safety circuit will "lock out" the system. To clear the lockout, **turn the fryer off** and follow steps 2–4 above.
7. If the flue exhaust fan fails, the gas control valve will shut off the gas supply.

### 4.4 ADJUSTING BURNERS

1. Fill the frypot with hot or cold water (**Non-KFC co-branded locations**) to the top OIL LEVEL line scribed in the back of the frypot. Main burner operation and initial controller calibration can be checked during this step.

**NOTE:** In KFC co-branded locations, oil must be used in place of water for burner testing.

2. Set the Thermatron dial to 200°F (93°C), just below that of boiling water.
3. Turn the fryer power switch on. The blower will activate and the main burner will ignite.
4. Check the main burners and, if necessary, adjust the burner dampers at each burner (**Figure 2, Page 4-4**) to obtain the best flame characteristics. An optimum flame should be blue at the base, 2-½ - 3" in height, and have a reddish-white tip ¾ to 1" in height. To adjust, loosen the screw of the air shutter, and open or close the shutter until the burner flame matches the optimum flame description above. Tighten the shutter screw, and repeat for all burners. The flame should be straight and not pulling to the rear of the fryer. If the flame is pulling to the rear, inspect the main rear baffle for heat damage and replace if necessary.
5. The burners should shut off just at the water starts to boil.
6. When satisfied that the burners and controller are operating properly, drain the frypot of water and dry thoroughly.
7. Immediately coat the frypot inside with oil to prevent rusting, or add new oil to the frypot if fryer is ready for use.

## 4.4 ADJUSTING BURNERS (cont.)

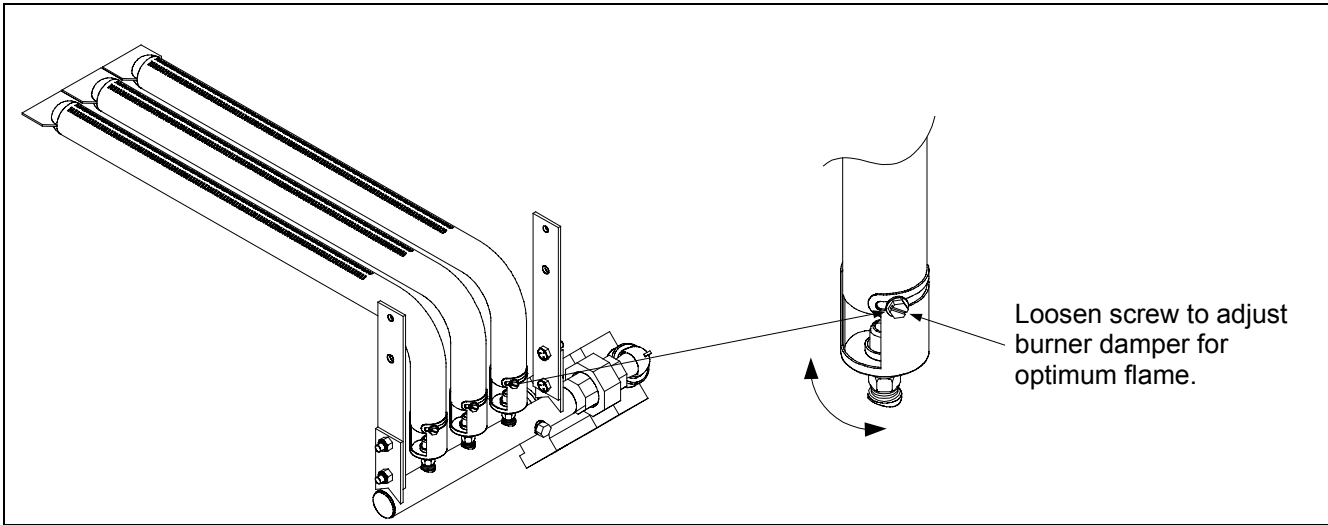

Figure 2: Burner damper adjustment on burner tubes.

**NOTE: In KFC co-branded locations, boil out is NOT ALLOWED. Use KFC approved procedure.**

### 4.4.1 Boil Out Procedure (Non-KFC Co-Branded Locations Only)

1. Turn off the fryer and drain the shortening from the fryer in accordance with filtering instructions.
2. Remove the Sensor Probe Guard (**Figure 1, Page 4-1**) and place it in the bottom of the fryer during boil-out.
3. Remove the frypot drain plug and install the drain extension prior to boil-out. Ensure the drain valve is closed prior to adding water and boil-out cleaner to frypot. **NEVER DRAIN WATER OR BOIL-OUT SOLUTION INTO THE FILTER SYSTEM. IRREPAIRABLE DAMAGE WILL RESULT.**
4. Scrape carbon buildup from the fryer walls and around the thermostat probes. Use care when cleaning the probes to avoid damaging them. Do not scrape the bottom of the fryer. (**For initial boil out, this step is not required.**)
5. Pour recommended amount of degreaser or cleaner into the fryer and add hot water to the upper OIL LEVEL line scribed in the back of the fryer.
6. Turn the fryer on. Switch the Thermatron controller to Boil-Out Mode (located in cabinet with power and reset switch) and continue. The burners should cycle off just as the boil-out solution comes to a boil.
7. Monitor the boil-out procedure constantly. If excessive foam starts to rise in the frypot, reduce the heat. **DO NOT LEAVE THE FRYER UNATTENDED DURING THE BOIL-OUT PROCEDURE.**

#### 4.4.1 Boil Out Procedure (cont.)

8. Continue the boil-out procedure for 20 minutes. Brush the sides and bottom of the frypot with an approved brush to remove deposits. Add hot water if needed to maintain the proper liquid level in the fryer.
9. Turn the fryer off and drain the boil-out solution into an appropriate container and discard. **DO NOT DRAIN BOIL-OUT SOLUTION INTO THE FILTER SYSTEM. IRREPARABLE DAMAGE WILL OCCUR AND ALL APPLICABLE WARRANTIES WILL BE VOIDED.**
10. Refill the frypot with clean water. Add 16 ounces of white vinegar, turn fryer on and bring solution to a simmer. Brush the sides and bottom of the frypot to remove boil-out residue. Turn the fryer off and drain the solution as discussed in Step 9. Rinse the frypot three additional times with clean water. Brush the sides and bottom to remove vinegar residue.
11. After the final rinse, dry the frypot thoroughly with paper towels, ensuring all traces of water are removed. **DO NOT USE CLOTH TOWELS TO DRY FRYPOT.** Inspect the high-limit and sensor probes for proper adjustment, and replace the sensor probe guard.
12. **Immediately coat the frypot with shortening to prevent the frypot from rusting.**
13. Close the drain valve, remove the drain extension and replace the frypot drain plug. Refill the fryer with shortening from the filtration system or see Section 4.5 for filling the vat with shortening.

#### 4.5 FILLING THE VAT WITH SHORTENING



#### **DANGER**

**NEVER MELT A SOLID BLOCK OF SHORTENING BY SETTING IT WHOLE IN THE FRYPOT. FRYPOT DAMAGE CAN OCCUR AND THE CHANCE OF FLASH-POINT FIRE INCREASES.**

1. Cut the block of shortening into small pieces and pack into the frypot bottom. Do not set a whole block of shortening into the frypot. **ENSURE THE BOTTOM OF THE FRYPOT IS COMPLETELY COVERED WITH SHORTENING BEFORE TURNING UNIT ON.** Continue packing the frypot to the lower OIL LEVEL line scribed into the back of the frypot.
2. Turn the Thermatron controller to the desired temperature after the frypot is properly filled with shortening. The burners will cycle in melt cycle mode until approximately 145°F (63°C), and then remain on until setpoint temperature is attained. The “green” indicator light (heat indicator) will cycle on and off at setpoint temperature.

## 4.6 FINAL PREPARATION

Before starting operation, turn the Thermatron controller to the desired shortening temperature, wait for the temperature to stabilize, and then check with a high-quality immersion thermometer.



### **WARNING**

**NEVER MOVE A FRYER FILLED WITH HOT LIQUID.**

**DO NOT GO NEAR THE AREA DIRECTLY OVER THE FLUE OUTLET WHEN THE MAIN BURNERS ARE OPERATING.**

**ALWAYS WEAR OIL-PROOF, INSULATED GLOVES WHEN WORKING WITH HOT OIL.**

**ALWAYS DRAIN HOT OIL INTO A METAL CONTAINER...HOT OIL CAN MELT PLASTIC BUCKETS AND SHATTER GLASS CONTAINERS.**

# LJS 24G SERIES FLATBOTTOM GAS FRYERS

## CHAPTER 5: DAILY OPERATION/FILTRATION

---

### 5.1 OPENING

At opening, check the fryer for:

1. Combination or main gas valve "OFF".
2. Power Switch "OFF" (If so equipped).

For lighting the fryer, see Section 4.2 (Section 4.3 if equipped with Electronic Ignition).

### 5.2 GENERAL OPERATIONS STATEMENT

See the LJS Operations Manual for operating instructions prior to using the LJS 24G Series gas fryer. Operating instructions in this chapter are intended for temporary use as a guide in absence of the LJS Operations Manual.

### 5.3 FILTERING

Shortening should be filtered at least daily, or more frequently if cooking is heavy. This assures the longest life possible for the shortening, imparts a better flavor to the product and minimizes flavor transfer. To ensure shortening quality, filtering and daily maintenance should be performed according to LJS Operations: Shortening Rotation System.



#### **WARNING**

**LEAVE FRYER OFF FOR A MINIMUM OF 10 MINUTES PRIOR TO FILTERING TO ALLOW FRYPOT HEAT TO DISSIPATE. FRYPOT DAMAGE CAN OCCUR IF THE SHORTENING IS DRAINED IMMEDIATELY AFTER TURNING FRYER OFF.**



#### **WARNING**

**WHEN OPERATING THE FILTRATION SYSTEM, NEVER LEAVE THE FILTER UNATTENDED. THE ACTION OF THE SHORTENING MOVING THROUGH THE HOSE LINES COULD JOLT A FLEXIBLE RETURN HOSE OUT OF THE FILTER PAN, SPRAYING HOT SHORTENING AND CAUSING SEVERE BURNS.**



#### **DANGER**

**THE CRUMB TRAY IN FRYERS EQUIPPED WITH A FILTER SYSTEM MUST BE EMPTIED INTO A FIREPROOF CONTAINER AT THE END OF FRYING OPERATIONS EACH DAY. SOME FOOD PARTICLES CAN SPONTANEOUSLY COMBUST IF LEFT SOAKING IN CERTAIN SHORTENING MATERIAL.**

## 5.4 FILTER PREPARATION

1. Assemble the filter pan, ensuring all components are clean and dry. When assembling the filter pan, follow LJS Operations: Shortening – Filtering, or the following in absence of LJS instructions:
2. Remove filter-pan lid.

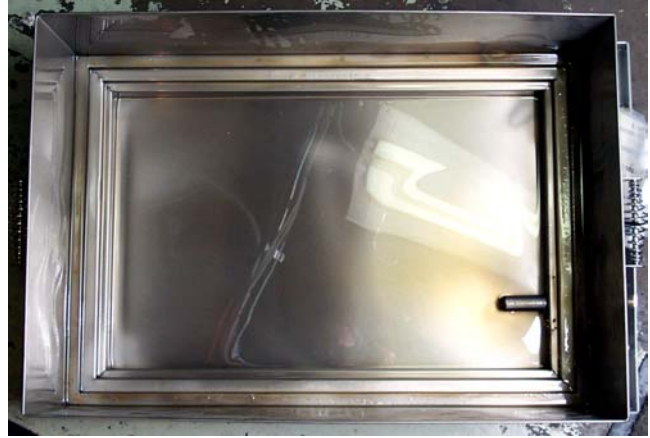

Filter pan with lid removed.

3. Place the filter leaf assembly in the bottom of the filter pan. Ensure the pick-up tube goes to the right side of the pan (when viewed from front).



Place filter leaf assembly in filter pan, ensuring proper placement of pick-up tube to the right side.

4. Sprinkle the prescribed amount of filter powder over the filter leaf assembly, ensuring even, overall coverage.



Applying filter powder to screen.

## 5.4 FILTER PREPARATION (cont.)

5. Place the crumb tray inside filter pan, in the proper position.



Place crumb tray in filter pan prior to replacing lid.

6. Replace the filter pan lid. Ensure pick-up tube emerges through hole in pan lid.



Ensure pick-up tube emerges through hole in pan lid.

7. Ensure filter system hose connection is properly attached to the filter leaf connection prior to activating filter pump.

8. See Section 5.5 for filtering instructions.

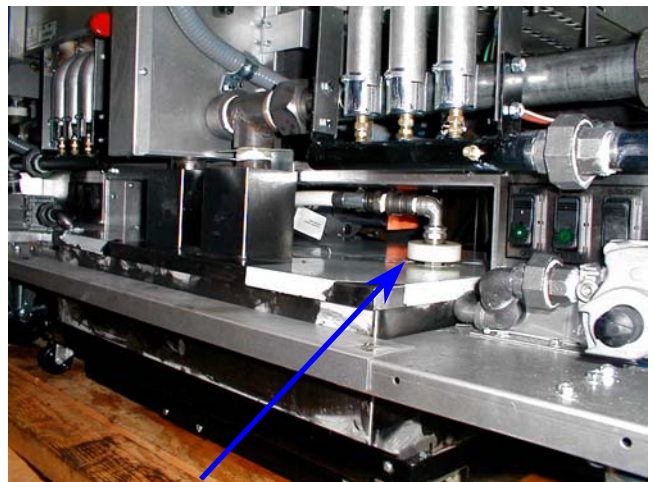

Ensure filter leaf connection is properly attached to filter system hose connection prior to activating filter pump.

## 5.5 FILTERING INSTRUCTIONS

 **WARNING**

**THE ON-SITE SUPERVISOR IS RESPONSIBLE FOR ENSURING THAT OPERATORS ARE MADE AWARE OF THE INHERENT DANGERS OF OPERATING A HOT OIL FILTER SYSTEM, PARTICULARLY ASPECTS OF OIL FILTRATION, DRAINING, AND CLEANING OF THE FILTER.**

The Flatbottom 24G Fryer System is equipped with the Under Fryer Filter (UFF). For optimum system performance, do the following:

- a. Use high-quality oil or shortening.
  - b. Filter daily or even more frequently if cooking is heavy. This assures the longest possible oil life, imparts a better flavor to the product and minimizes flavor transfer.
  - c. Ensure oil-return lines are clear before turning off the filter pump and hang any flexible lines up to drain. Solid shortening will solidify as it cools and clog the lines.
- A. Assemble tools for filtering. All except the squeegee are supplied with the filter starter kit:
1. Squeegee- used to clean the frypot while filtering.
  2. Clean-Out Rod - long rod used to dislodge heavy debris in the drain tube.
  3. Filter Powder.
  4. Filter Leaf Assembly (Follow procedure in Section 5.4 for filter leaf installation).

 **CAUTION**

**USE ONLY APPROVED FILTER POWDER FOR BEST RESULTS. USE OF NON-APPROVED POWDER CAN CAUSE SYSTEM DAMAGE AND PREMATURE PUMP FAILURE.**

- B. The following tools are not required, but are recommended to make filtering easier.
1. Measuring Cup - used to measure filter powder.
  2. Stainless Steel Crumb Scoop - for removing debris.
- C. Always wear oil-resistant, insulated gloves and/or protective gear when working with hot oil.
- D. Put on protective gear.
- E. Pull the UFF filter pan out from fryer/ filter cabinet. Remove cover.
- F. Remove filter leaf following instructions in Section 5.7.

## 5.5 FILTERING INSTRUCTIONS (cont.)

- G. Clean the filter pan thoroughly and ensure all components are completely dry.
- H. Follow directions outlined in Section 5.4- Filter Preparation, pages 5-2 – 5-3.



Ensure filter pan and all components are clean and dry before installing filter leaf assembly and crumb tray.

## 5.6 FILTER OPERATION

1. Turn the fryer OFF and allow the oil to cool for a minimum of 10 minutes before draining oil into filter pan.
2. Immediately before draining, use correct straining method to collect large debris suspended in oil.
3. Open the frypot drain valve.
4. Squeegee the frypot sides to remove any debris. Use the clean-out rod to clear the drain if necessary.

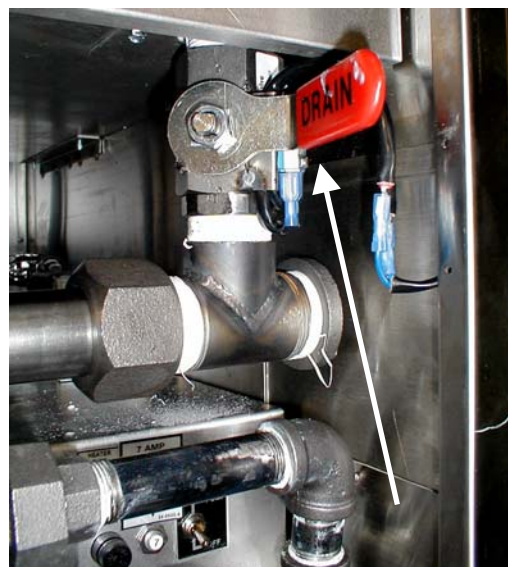

LJS 24G drain valve location.

## 5.6 FILTER OPERATION (cont.)

5. Move the oil-return handle from left to right to open the oil-return line. The filter pump will activate.

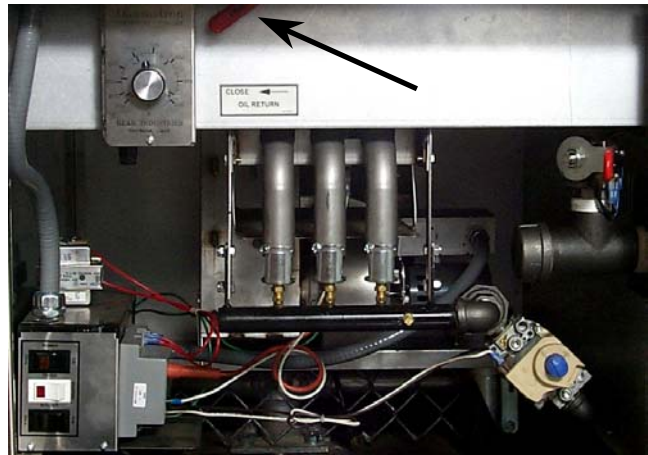

LJS 24G oil-return handle location.

6. If the filter pump does not activate when the oil-return handle is opened, check the circuit breaker to see if it needs resetting. If the circuit breaker cannot be reset, see page 5-10 for filtration system troubleshooting.
7. **Polishing:** Leave the fryer drain valve open for approximately 5 minutes and allow the oil to circulate through the frypot, back into the filter. Polishing extends oil life and improves cooking flavor.
8. Close the fryer drain valve. The frypot will begin to fill.

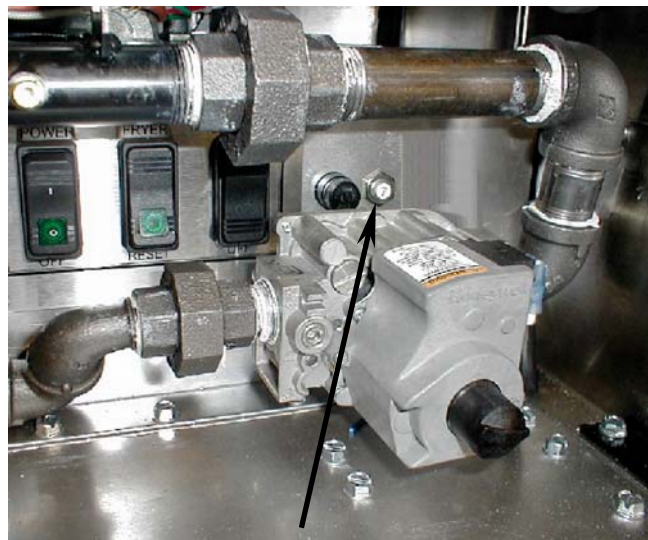

UFF filter pump circuit breaker.

9. Allow the filter to pump bubbles into the fryer for 15-30 seconds to clear the oil return lines.
10. Close the oil-return handle to shut filter pump off.



Allow the oil to bubble for 15-30 seconds after the filter pan is empty to clear the oil-return lines.

## 5.6 FILTER OPERATION (cont.)

**NOTE: If using solid shortening, ensure the oil-return lines are clear before turning off the pump motor. Hang all flexible hoses up to drain after filtration is complete. Failure to do so increases the likelihood of solidified shortening clogging the lines.**

11. Immediately empty the crumb tray into a fireproof container after filtering is complete. Clean and dry the filter pan and associated components as instructed in Sections 5.4 and 5.5.



Empty contents of the crumb screen into a fireproof container immediately after filtering is complete.

## 5.7 Disassembling/Assembling and Cleaning the Magnum Filter Leaf

LJS 24G Series fryers with UFF filtration come equipped with a filter leaf, which eliminates the need for filter paper. The filter leaf requires specific cleaning and assembly procedures. In the absence of cleaning and disassembly/reassembly instructions shipped with the filter leaf, use the following procedure:

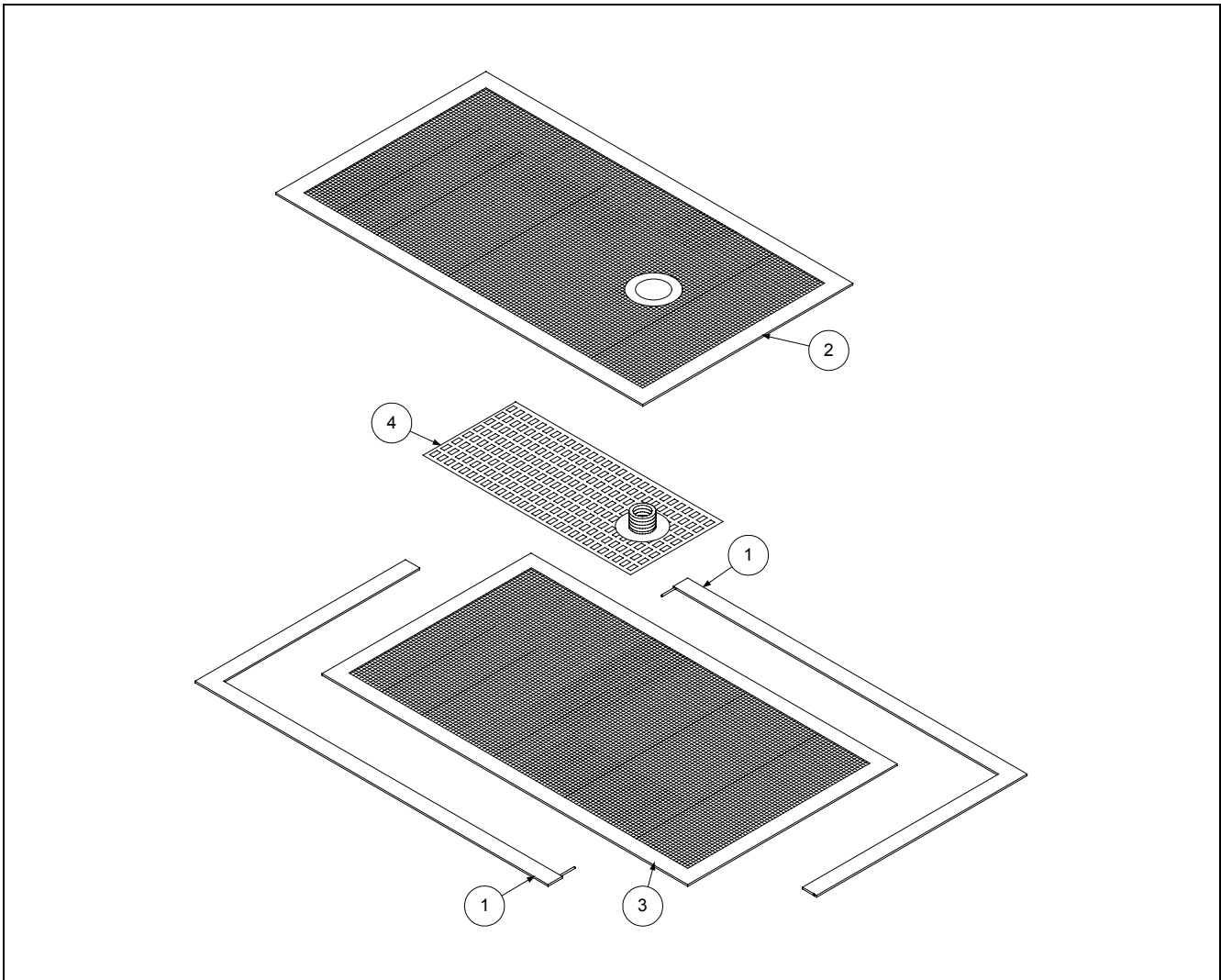

### 5.7.1 Filter Leaf Disassembly/Assembly

Grasp the seal frame near each corner at the locking tab ( ① ) and pull frame apart (see illustration above). The seal frame will separate into two pieces. Separate the top and bottom screens ( ② & ③ ) and remove the grid ( ④ ). Assemble in reverse order.

## 5.7.2 Cleaning the Filter Leaf Assembly

Clean the two seal frame pieces, screens and grid using a good quality degreaser and hot water from a spray nozzle. The groove in the seal frame pieces can be cleaned with the edge of a Scotch-Brite or similar cleaning pad.

At each scheduled boil out, disassemble the filter leaf as described in Section 5.7.1 and place in the frypot filled with boil-out solution. Follow the boil-out procedure in Section 4.4.1, including placing the filter leaf in the vinegar solution to neutralize boil-out residue, and clean water to rinse away vinegar residue. In KFC co-branded locations, follow KFC approved procedure for cleaning the filter leaf assembly.

Allow all filter leaf components to air dry or thoroughly dry with paper towels.

**NOTE: In KFC co-branded locations, boil out is NOT ALLOWED. Use KFC approved procedure.**

## 5.8 CLOSING

When closing at night, filter the shortening as described in Sections 5.3–5.6. Cover open frypots of oil with vat covers. Turn the power switch off and turn the control knob on the pilot safety valve to "OFF".

### 5.8.1 Shutdown For Extended Periods

1. When shutting down for longer than overnight, drain the shortening, clean the frypot thoroughly, and either discard the shortening or return it filtered to the frypot and cover it. If shortening is not returned to the frypot, immediately coat the frypot with shortening to prevent rust from forming.
2. Turn the manual valve on the incoming service line or combination gas valve to "OFF".
3. Disconnect any power cords from the wall sockets or turn off the circuit breakers.

**SEE SECTION 4 FOR INITIAL STARTUP AND FRYER OPERATION**

## 5.9 FILTER TROUBLESHOOTING

The problems and possible solutions covered are those most commonly encountered.

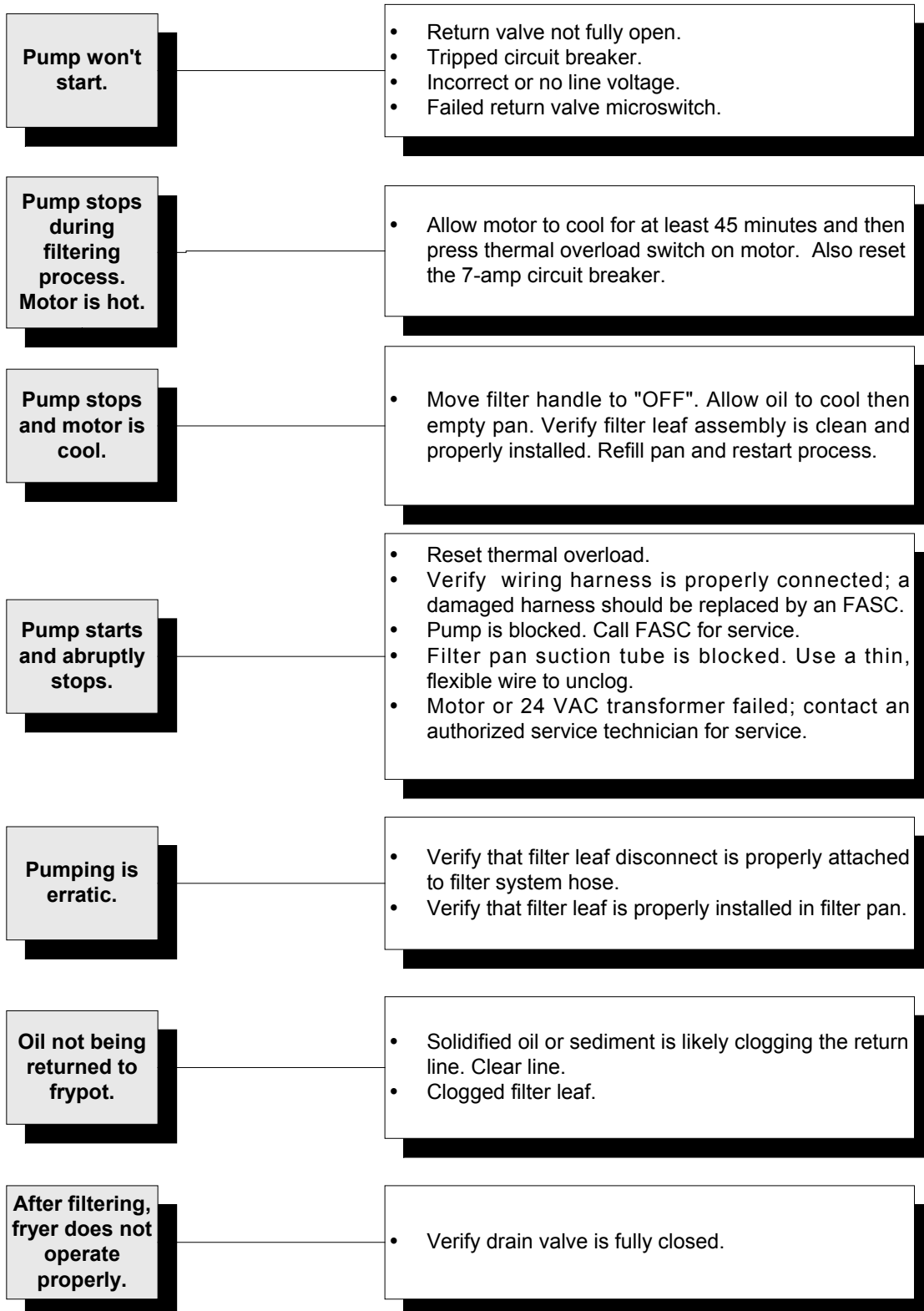

# LJS 24G SERIES FLATBOTTOM GAS FRYERS

## CHAPTER 6: PREVENTATIVE MAINTENANCE

---

Consult the LJS Operations Manual for cleaning and maintenance instructions. Cleaning and maintenance instructions in this chapter are intended for temporary use as a guide in absence of the LJS Operations Manual.

### 6.1 Daily Fryer Maintenance

Follow procedures in LJS Operations: Shortening – Filtering, Daily Fryer Maintenance section.

### 6.2 Daily

Remove and wash all removable parts in hot, soapy water. Rinse in clean water and dry thoroughly.

Clean all exterior surfaces of the fryer cabinet. DO NOT USE ABRASIVE CLEANSERS, STEEL WOOL OR OTHER ABRASIVE MATERIAL TO CLEAN STAINLESS STEEL. See Section 6.5 for stainless steel care.

Filter the oil and replace if necessary. Filter oil more frequently if use is heavy.

### 6.3 Monthly

Drain the frypot into the filter system or a metal container. Do not use plastic or glass containers for hot oil.

Follow boil-out procedures (**Non-KFC co-branded locations only**) in the LJS Operations Manual.

**NOTE: In KFC co-branded locations, boil out is NOT ALLOWED. Use KFC approved procedure.**

Refill with oil as described in the LJS Operations Manual, or as described in Section 4.5, Filling The Vat With Shortening.

## 6.4 Periodic

The fryer should be inspected and adjusted periodically by qualified service personnel as part of a regular kitchen maintenance program.

**Frymaster/Dean recommends that the fryer be inspected at least annually by a Factory Authorized Service Technician as follows:**

- Inspect fryer cabinet inside and out, front and rear, for excessive oil build up and/or oil migration. Verify that burners and associated components (i.e. gas valves, pilot assemblies, ignitors, etc.) are in good condition and functioning properly. Inspect all gas connections for leaks and ensure all connections are properly tightened.
- Verify that temperature and high-limit probes are properly connected, tightened and functioning properly.
- Verify all component box components (i.e. computer/controller, relays, transformers, interface boards, etc.) are in good condition and free from oil migration build up and other debris. Inspect component box wiring and ensure all connections are tight and all wiring is in good condition. Ensure all safety features (i.e. drain safety switches, reset switches, etc.) are present and functioning properly.
- Verify that the frypot is in good condition and free of leaks. Verify that frypot tube diffusers are present and in good condition (i.e. no visible deterioration or damage).
- Verify that all wiring and connections are tight and in good condition.

### **Built-in Filtration:**

- Inspect all oil-return and drain lines for leaks and verify that all connections are tight.
- Inspect the filter pan for leaks and cleanliness. If there is a large accumulation of crumbs in the crumb basket, advise the owner/operator that the crumb basket should be emptied into a fireproof container and cleaned daily.
- Verify that all O-rings and seals (including those on quick-disconnect fittings) are present and in good condition. Replace O-rings and seals if worn or damaged.

## 6.4 Periodic (cont.)

- Check filtration system integrity as follows:
  - With the filter pan empty, place each oil return handle, one at a time, in the "ON" position. Verify that the pump activates and that bubbles appear in the cooking oil/shortening of the associated frypot.
  - Close all oil return valves (i.e., place all oil return handles in the "OFF" position). Verify proper functioning of each oil return valve by activating the filter pump using the lever on one of the oil return handle microswitches. No air bubbles should be visible in any frypot.
  - Verify that the filter pan is properly prepared for filtering. After heating the oil to operating temperature [ $\sim 350^{\circ}\text{F}$  ( $177^{\circ}\text{C}$ )], turn fryer off and allow frypot to cool for 10 minutes. Drain the oil into the filter pan and close the frypot drain valve. Place the oil return handle in the "ON" position. Allow all cooking oil to return to the frypot (indicated by bubbles in the cooking oil/shortening. Return the oil return handle to the "OFF" position. The frypot should refill in no more than 2 minutes and 30 seconds.

**To ensure good fryer health and a safe environment, the fryer should be checked and adjusted periodically by qualified service personnel as part of a regular kitchen maintenance program.**

## 6.5 Stainless Steel Care

All stainless steel fryer cabinet parts should be wiped regularly with hot, soapy water during the day, and with a liquid cleanser designed for stainless steel at the end of each day.

- A. Do not use steel wool, abrasive cloths, cleansers or powders.
- B. Do not use a metal knife, spatula or any other metal tool to scrape stainless steel! Scratches are almost impossible to remove.
- C. If it is necessary to scrape the stainless steel to remove any encrusted materials, soak the area first to soften the deposit, then use a wood or nylon scraper only.

**THIS PAGE INTENTIONALLY LEFT BLANK.**

# LJS 24G SERIES FLATBOTTOM GAS FRYERS

## CHAPTER 7: TROUBLESHOOTING

**FACTORY APPROVAL MUST BE OBTAINED PRIOR TO ANY WARRANTY WORK BEING DONE OR DEAN CANNOT BE HELD RESPONSIBLE.**

The following procedures **must be performed** by Factory Authorized Service Technicians, and are provided as an aid to expedite troubleshooting and repair of LJS 24G Series frying systems.

### 7.1 PILOT BURNER MALFUNCTIONS

PROBLEM	CORRECTIVE ACTION
<b>Pilot will not ignite; no evidence of gas at pilot burner.</b>	Ensure the combination gas valve is in PILOT position and that gas is available at the control valve (check quick-disconnect and/or gas-line connections for proper connection).
<b>Pilot burner ignites but will not remain lit when gas knob is released.</b>	Pilot flame may be adjusted incorrectly. Adjust flame to 1½" high by turning pilot flow adjustment screw.
<b>Pilot burner ignites properly and burns properly, but goes out when the exhaust blower comes on.</b>	<ol style="list-style-type: none"><li>1. Pilot flame may be adjusted too low, even though it appears to be satisfactory. Re-adjust higher as described earlier.</li><li>2. Pilot flame may be adjusted too high and is on the verge of blowing out. Re-adjust lower.</li></ol>

## 7.2 MAIN BURNER MALFUNCTIONS

PROBLEM	CORRECTIVE ACTION
<p><b>Main burner will not come on even though air blower is in operation; no gas pressure at main burner.</b></p>	<ol style="list-style-type: none"> <li>1. Check that the combination gas valve is ON.</li> <li>2. Check that the pilot is lit and is operating properly.</li> </ol>
<p><b>Air blower is not operating, although power is present at the fryer.</b></p>	<ol style="list-style-type: none"> <li>1. Cooked product or other material may have fallen into the flue and lodged in the blower wheel, preventing it from turning. Clean out flue and blower wheel.</li> <li>2. Blower motor may have overheated and shut off. This condition will correct itself when motor cools (20 minutes). If problems with blower overheating persist, call for service.</li> <li>3. If fryer is equipped with a Thermatron controller, the temperature probe or the controller board may be defective. Call for service.</li> </ol>
<p><b>Signs of excessive frypot temperature; Oil quickly becomes discolored.</b></p>	<ol style="list-style-type: none"> <li>1. Check Thermatron controller; may be out of calibration. Re-calibrate in accordance with instructions in Section 7.4.</li> <li>2. Shortening of inferior quality or used too long. Replace with quality shortening.</li> </ol>

## 7.3 INDICATOR LIGHTS

The fryer's indicator lights serve a diagnostic purpose. All lights are lit when the fryer is working properly. (The green light on the control panel will cycle on and off as the fryer calls for heat). Use the following procedures to isolate problems indicated by light combinations. Lighting sequences not listed are beyond the scope of operator correction; call an authorized service agent.

Turn the temperature dial to 400°F (204°C) to ensure the sensor will demand heat. Check all indicator lights in the fryer cabinet and on the control panel. [Older units may have power and reset switches with different colored lights (orange, amber, red, etc.). Substitute the light color of the old switch with the respective "green light" switch in the following troubleshooting procedures. The control panel light colors haven't changed.]

## 7.3 INDICATOR LIGHTS (cont.)

When turning the power switch "ON" and resetting the safety (reset) switch, check for the following:

LIGHT INDICATION	PROBABLE CAUSE	CORRECTIVE ACTION
<p><b>GREEN LIGHT/POWER SWITCH IS "ON"</b></p> <p><b>GREEN LIGHT/SAFETY (RESET) SWITCH IS "OFF"</b></p> <p><b>GREEN LIGHT/CONTROL PANEL IS "OFF"</b></p> <p><b>RED LIGHT/CONTROL PANEL IS "OFF"</b></p>	<p>1. The drain valve is open.</p> <p>2. The drain switch is defective.</p>	<p>1. Ensure the drain valve is completely closed, and then turn the reset switch to "ON".</p> <p>2. If the light on the reset switch does not turn on, contact a Factory Authorized Service Center for assistance.</p>
<p><b>GREEN LIGHT/POWER SWITCH IS "OFF"</b></p> <p><b>GREEN LIGHT/SAFETY (RESET) SWITCH IS "OFF"</b></p> <p><b>GREEN LIGHT/ CONTROL PANEL IS "OFF"</b></p> <p><b>RED LIGHT/CONTROL PANEL IS "OFF"</b></p>	<p>1. No power to fryer.</p> <p>2. Fuse is blown.</p>	<p>1. Check power source, power cords and breaker. Ensure that electricity is available to the fryer.</p> <p>2. Replace fuse. If fuse continues to blow, contact a Factory Authorized Service Center.</p> <p>3. If fryer does not function after resetting the reset switch, contact a Factory Authorized Service Center for assistance.</p>

## 7.4 THERMATRON CONTROLLER CALIBRATION

If the Thermatron controller requires adjustment, do the following:

1. Set Thermatron controller dial to the desired shortening temperature and wait for the shortening temperature to stabilize.
2. When shortening temperature reaches setpoint (heat light will go off), check the temperature with a high-quality immersion thermometer.
3. Loosen two knob setscrews and rotate the knob to the correct temperature setting on the Thermatron faceplate.
4. Check the temperature again with a high-quality immersion thermometer to confirm that the setting is correct.
5. Re-tighten both knob setscrews at the calibrated position.

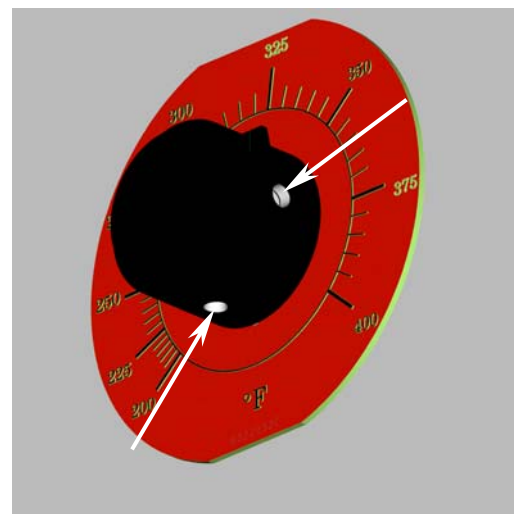

Loosen two setscrews in dial (arrows) to recalibrate controller.

# 7.5 WIRING DIAGRAMS

## 7.5.1 LJS 2424GTI With Drain Safety Switch and Boil Out

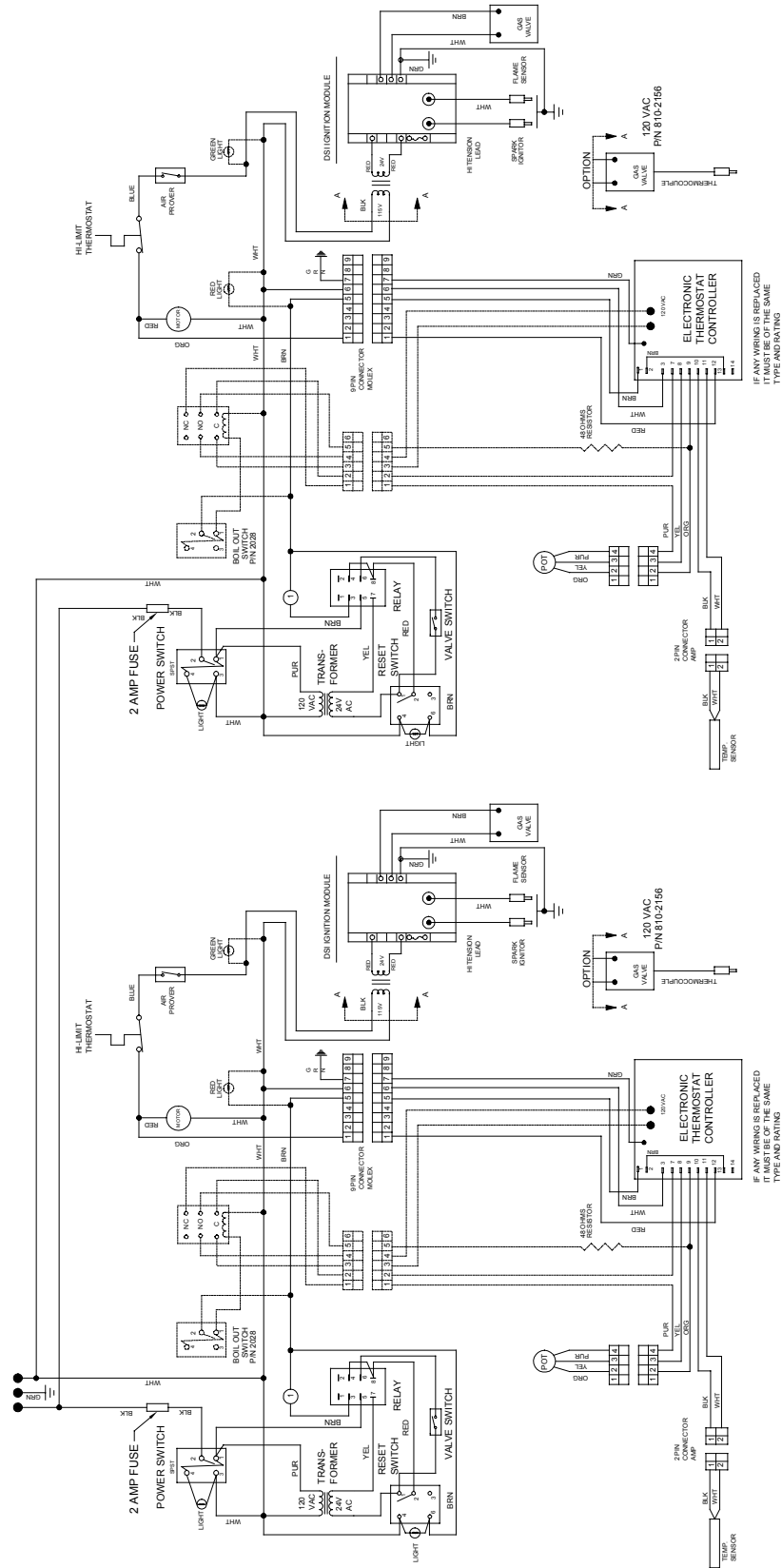

## 7.5.2 KFC 2424GTI With Drain Safety Switch, Boil-Out Disabled

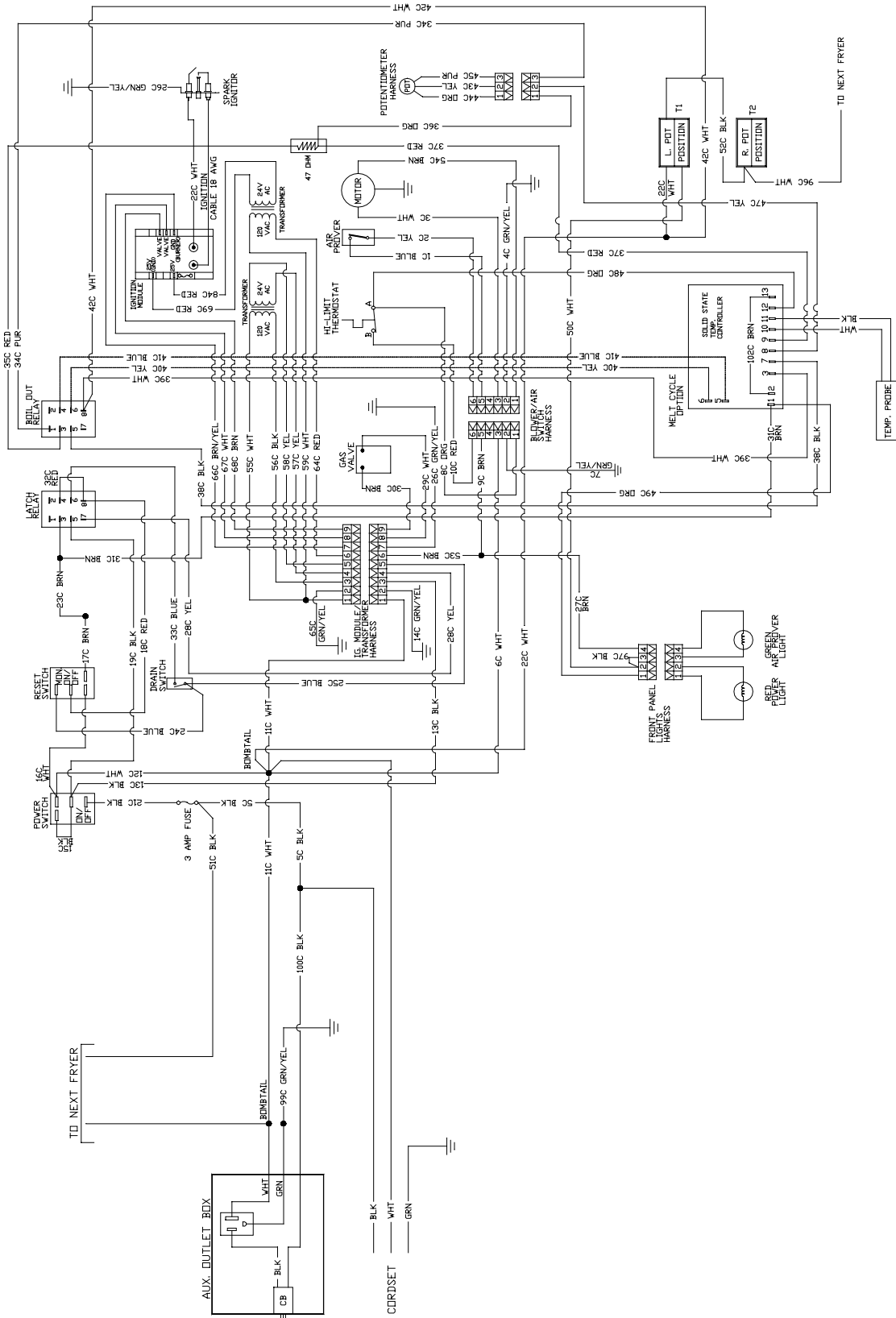

### 7.5.3 2424GTI Oil Return/Filter System

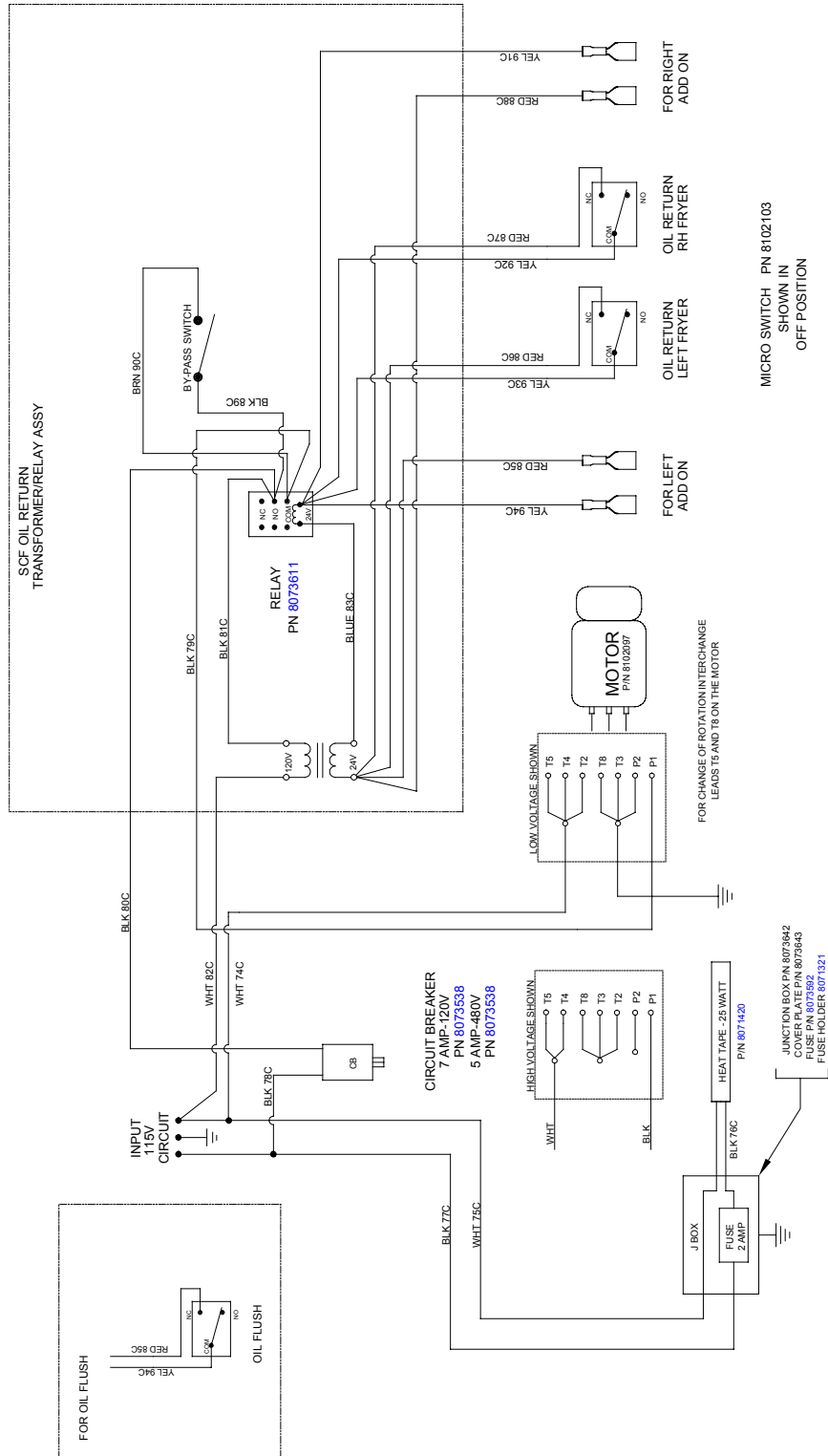

8051477A

**THIS PAGE INTENTIONALLY LEFT BLANK.**



Enodis®  
One Company, Countless Solutions

Frymaster/Dean, 8700 Line Avenue, PO Box 51000, Shreveport, Louisiana 71135-1000  
Shipping Address: 8700 Line Avenue, Shreveport, Louisiana 71106

TEL 1-318-865-1711

FAX (Parts) 1-318-688-2200

FAX (Tech Support) 1-318-219-7135

PRINTED IN THE UNITED STATES

SERVICE HOTLINE  
1-800-551-8633

819-5758  
MARCH 2004