



2836 Series Electric Fryers

Installation and Operation Manual



Frymaster, a member of the Commercial Food Equipment Service Association, recommends using CFESA Certified Technicians.

24-Hour Service Hotline 1-800-551-8633

10/2022



Please read all sections of this manual and retain for future reference.

NOTICE

This appliance is intended for professional use only and is to be operated by qualified personnel only. A Frymaster Dean Factory Authorized Servicer (FAS) or other qualified professional should perform installation, maintenance, and repairs. Installation, maintenance, or repairs by unqualified personnel may void the manufacturer's warranty. See Chapter 1 of this manual for definitions of qualified personnel.

NOTICE

This equipment must be installed in accordance with the appropriate national and local codes of the country and/or region in which the appliance is installed.

NOTICE

Drawings and photos used in this manual are intended to illustrate operational, cleaning and technical procedures and may not conform to onsite management operational procedures.

NOTICE TO OWNERS OF UNITS EQUIPPED WITH COMPUTERS

U.S.

This device complies with Part 15 of the FCC rules. Operation is subject to the following two conditions: 1) This device may not cause harmful interference, and 2) This device must accept any interference received, including interference that may cause undesired operation. While this device is a verified Class A device, it has been shown to meet Class B limits.

CANADA

This digital apparatus does not exceed the Class A or B limits for radio noise emissions as set out by the ICES-003 standard of the Canadian Department of Communications.

Cet appareil numérique n'émet pas de bruits radioélectriques dépassant les limites de classe A et B prescrites dans la norme NMB-003 édictée par le Ministre des Communications du Canada.

 DANGER

Improper installation, adjustment, maintenance or service, and unauthorized alterations or modifications can cause property damage, injury, or death. Read the installation, operating and service instructions thoroughly before installing or servicing this equipment

 DANGER

This fryer must not be modified to serve as a water-bath unit. This is especially dangerous if adjoining frypots are used for conventional frying. Water splashing or falling into hot oil causes dangerous eruptions in the oil. Personnel near the fryer can be seriously injured.

 DANGER

Adequate means must be provided to limit the movement of this appliance without depending upon the electrical connection. Single fryers equipped with legs must be stabilized by installing anchor straps. All fryers equipped with casters must be stabilized by installing restraining chains.

⚠ DANGER

The front ledge of the fryer is not a step. Do not stand on the fryer. Serious injury can result from slips or contact with the hot oil.

⚠ DANGER

Do not store or use gasoline or other flammable vapors and liquids in the vicinity of this or any other appliance.

⚠ DANGER

The crumb tray in fryers equipped with a filter system must be emptied into a fireproof container at the end of frying operations each day. Some food particles can spontaneously combust if left soaking in certain shortening material. Additional information can be obtained in the filtration manual included with the system.

⚠ WARNING

No structural material on the fryer should be altered or removed to accommodate placement of the fryer under a hood. Questions? Call the Frymaster Dean Service Hotline at 1-800-551-8633.

⚠ WARNING

Do not bang fry baskets or other utensils on the fryer's joiner strip. The strip is present to seal the joint between the frypot. Banging fry baskets on the strip to dislodge shortening will distort the strip, adversely affecting its fit. It is designed for a tight fit and should only be removed for cleaning.

NOTICE

IF, DURING THE WARRANTY PERIOD, THE CUSTOMER USES A PART FOR THIS FRYMASTER DEAN EQUIPMENT OTHER THAN AN UNMODIFIED NEW OR RECYCLED PART PURCHASED DIRECTLY FROM FRYMASTER DEAN, OR ANY OF ITS AUTHORIZED SERVICE CENTERS, AND/OR THE PART BEING USED IS MODIFIED FROM ITS ORIGINAL CONFIGURATION, THIS WARRANTY WILL BE VOID. FURTHER, FRYMASTER DEAN AND ITS AFFILIATES WILL NOT BE LIABLE FOR ANY CLAIMS, DAMAGES OR EXPENSES INCURRED BY THE CUSTOMER WHICH ARISE DIRECTLY OR INDIRECTLY, IN WHOLE OR IN PART, DUE TO THE INSTALLATION OF ANY MODIFIED PART AND/OR PART RECEIVED FROM AN UNAUTHORIZED SERVICE CENTER.

⚠ DANGER

Adequate means must be provided to limit the movement of this appliance without depending on or transmitting stress to the electrical conduit. A restraint kit is provided with the fryer. If the restraint kit is missing contact your local Frymaster Factory Authorized Service Center (FASC) for part number 826-0900.

⚠ DANGER

This fryer may have two power cords and prior to movement, testing, maintenance and any repair on your Frymaster fryer; disconnect BOTH electrical power cords from the electrical power supply.

NOTICE

All fryers shipped without factory supplied cords and plug assemblies must be hardwired using flexible conduit to the terminal block located on the rear of the fryer. These fryers should be wired to NEC specifications. Hardwired units must include installation of restraint devices.



**2836 SERIES ELECTRIC FRYERS
INSTALLATION & OPERATION MANUAL**

TABLE OF CONTENTS

	Page
1. INTRODUCTION.....	1-1
1.1 General.....	1-1
1.2 Safety Information.....	1-1
1.3 Computer Information.....	1-2
1.4 Shipping Damage Claim Procedure.....	1-2
1.5 Service Information.....	1-3
1.6 After Installation.....	1-3
1.7 Definitions.....	1-3
2. INSTALLATION AND OPERATING INSTRUCTIONS.....	2-1
2.1 General.....	2-1
2.2 Fryer Installation.....	2-2
2.3 Power Requirements.....	2-3
2.4 Frypot Boil-Out.....	2-3
2.5 Equipment Start-up and Shutdown Procedures.....	2-4
3. PREVENTATIVE MAINTENANCE.....	3-1
3.1 Cleaning Fryer.....	3-1
3.2 Periodic/Annual Maintenance.....	3-2
4. BUILT-IN FILTRATION.....	4-1
4.1 Preparing the Filter System for Use.....	4-1
4.2 Daily Filter Operation.....	4-2
4.3 Operating the Filter/Oil Disposal.....	4-3
5. OPERATOR TROUBLESHOOTING.....	5-1
5.1 Introduction.....	5-1
5.2 Troubleshooting.....	5-2

2836 SERIES ELECTRIC FRYERS

CHAPTER 1: INTRODUCTION

1.1 General

Read the instructions in this manual thoroughly before attempting to operate this equipment. This manual covers all 2836 Series Electric Fryers.

2836 Series electric fryers feature easy to clean, open frypots with tilt-up elements. The fryers are controlled by multi-product cooking computers and come in full-pot configurations.

1.2 Safety Information

Before attempting to operate your unit, read the instructions in this manual thoroughly.

Throughout this manual, you will find notations enclosed in double-bordered boxes similar to the ones below.

CAUTION

CAUTION boxes contain information about actions or conditions that *may cause or result in a malfunction of your system.*

WARNING

WARNING boxes contain information about actions or conditions that *may cause or result in damage to your system,* and which may cause your system to malfunction.

DANGER

DANGER boxes contain information about actions or conditions that *may cause or result in injury to personnel,* and which may cause damage to your system and/or cause your system to malfunction.

Fryers in this series are equipped with automatic safety features:

1. Two high-temperature detection features shut off power to the elements should the temperature controls fail.

If the computer display shows HELP, HOT or Prob, the fryer is malfunctioning. Press the ON/OFF switch  to the “OFF” position (the LED displays on the computer go dark) or disconnect the fryer from the electrical power supply. Do not operate the fryer until an FASC technician has serviced it.

NOTE: 2836 Series fryers may have more than one power cord. Whenever disconnecting the fryer from the electrical power supply, verify that all cords have been disconnected or that all circuit breakers have been turned off.

2. A float switch located in the frypot will not allow the elements to be energized without sufficient oil in the frypot to safely cover the elements.

3. Drain safety switches on the frypot drain valves will not allow the elements to be energized unless each drain valve is completely closed. Opening a drain valve will cause the elements to be de-energized.
4. An inline circuit breaker shuts off power to the filter-pump motor (if so equipped) if the motor overheats.

NOTE: 2836 Series fryers may have more than one power cord. Whenever disconnecting the fryer from the electrical power supply, verify that all cords have been disconnected or that all circuit breakers have been turned off.

1.3 Computer Information

This equipment has been tested and found to comply with the limits for a Class A digital device, pursuant to Part 15 of the FCC rules. While this device is a verified Class A device, it has been shown to meet the Class B limits. These limits are designed to provide reasonable protection against harmful interference when the equipment is operated in a commercial environment. This equipment generates, uses and can radiate radio frequency energy and, if not installed and used in accordance with the instruction manual, may cause harmful interference to radio communications. Operation of the equipment in a residential area is likely to cause harmful interference in which case the user will be required to correct the interference at their own expense.

The user is cautioned that any changes or modifications not expressly approved by the party responsible for compliance could void the user's authority to operate the equipment.

If necessary, the user should consult the dealer or an experienced radio and television technician for additional suggestions.

The user may find the following booklet prepared by the Federal Communications Commission helpful: "How to Identify and Resolve Radio-TV Interference Problems". This booklet is available from the U.S. Government Printing Office, Washington, DC 20402, Stock No. 004-000-00345-4.

1.4 Shipping Damage Claim Procedure

What to do if your equipment arrives damaged:

Please note that this equipment was carefully inspected and packed by skilled personnel before leaving the factory. The freight company assumes full responsibility for safe delivery upon acceptance of the equipment.

1. File Claim for Damages Immediately—Regardless of the extent of damage.
2. Visible Loss or Damage—Be sure this is noted on the freight bill or express receipt and is signed by the person making the delivery.
3. Concealed Loss or Damage—If damage is unnoticed until equipment is unpacked, notify the freight company or carrier immediately and file a concealed damage claim. This should be done within 15 days of date of delivery. Be sure to retain container for inspection.

1.5 Service Information

For non-routine maintenance or repairs, or for service information, contact your local Frymaster Authorized Service Center (FASC). Service information may also be obtained by calling the Frymaster Technical Services Department (1-800-551-8633). The following information will be needed in order to assist you efficiently:

Model Number _____

Serial Number _____

Voltage _____

Nature of the Problem _____

1.6 After Installation

In order to improve service, please have the table below filled in by the Frymaster/Dean Authorized Service Technician who installed this equipment.

Technician's Name	_____
FASC Name	_____
FASC Address	_____

FASC Telephone/Fax	_____
Model Number	_____
Serial Number(s)	_____
Voltage	_____

1.7 Definitions

1. Qualified and/or Authorized Operating Personnel

Qualified/authorized operating personnel are those who have carefully read the information in this manual and have familiarized themselves with the equipment functions, or have had previous experience with the operation of equipment covered in this manual.

2. Qualified Installation Personnel

Qualified installation personnel are individuals, or firms, corporations, or companies that, either in person or through a representative, are engaged in and are responsible for the installation of electrical appliances. Qualified personnel must be experienced in such work, be familiar with all electrical precautions involved, and have complied with all requirements of applicable national and local codes.

3. **Qualified Service Personnel**

Qualified service personnel are those who are familiar with Frymaster/Dean equipment and have been authorized by Frymaster/Dean to perform service on Frymaster/Dean equipment. All authorized service personnel are required to be equipped with a complete set of service parts manuals and stock a minimum amount of parts for Frymaster/Dean equipment. A list of Frymaster/Dean Factory Authorized Service Centers (FASCs) was included with the fryer when shipped from the factory. *Failure to use qualified service personnel will void the Frymaster/Dean warranty on your equipment.*

RETAIN AND STORE THIS MANUAL IN A SAFE PLACE FOR FUTURE USE.

2836 SERIES ELECTRIC FRYERS

CHAPTER 2: INSTALLATION AND OPERATING INSTRUCTIONS

2.1 General

Proper installation is essential for the safe, efficient, trouble-free operation of this appliance. Any unauthorized alteration of this equipment will void the Frymaster warranty.

NOTICE

This equipment must be positioned so that the plug is accessible unless other means for disconnection from the power supply (e.g., a circuit breaker) is provided.

DANGER

Do not store or use gasoline or other flammable vapors and liquids in the vicinity of this or any other appliance.

WARNING

Do not attach accessories to this fryer unless the fryer is secured from tipping. Personal injury may result.

All installation and service on Frymaster equipment must be performed by qualified, certified, licensed, and/or authorized installation or service personnel.

Service may be obtained by contacting your local Factory Authorized Service Center.

In the event of a power failure, the fryer(s) will automatically shut down. If this occurs, turn the power switch "OFF". Do not attempt to start the fryer(s) until power is restored.

This appliance must be kept free and clear of combustible material, except that it may be installed on combustible floors.

A clearance of 6 inches (15cm) must be provided at both sides and back adjacent to combustible construction. A minimum of 24 inches (61cm) should be provided at the front of the equipment for servicing and proper operation.

WARNING

Do not block the area around the base or under the fryers.

2.2 Fryer Installation

 **WARNING**

Frymaster fryers equipped with legs are for permanent installations. Fryers fitted with legs must be lifted during movement to avoid damage and possible bodily injury. For a moveable or portable installation, Frymaster optional equipment casters must be used.

Questions? Call 1-800-551-8633

1. Move the fryer to the general location where it will be installed.
2. Using wiring that complies with the Power Requirements table on Page 2-3 and the rating plates affixed to the inside of the fryer doors, connect the customer-supplied power cords to the fryer in accordance with the wiring diagram affixed to the inside of the fryer door.
3. After the wiring connections have been made, move the fryer into its final position under its hood and ensure that it is level.

To level fryers equipped with legs, the bottom of the legs can be screwed out up to 1-inch for leveling. Legs should be adjusted so that the fryer is at the proper height in the frying station. For fryers equipped with casters, there are no built-in leveling devices. The floor where the fryer is installed must be level.

NOTE: If you need to relocate a fryer installed with legs, remove all the weight from each leg before moving. If a leg is damaged, contact your service agent for immediate repair or replacement.

 **WARNING**

Hot shortening can cause severe burns. Under all circumstances, oil must be removed from the fryer before attempting to move it to avoid oil spills and the falls and severe burns that could occur.

4. Once the fryer is in its final position and has been leveled, install the restraints provided with the fryer to limit its movement so that it does not depend on or transmit stress to the electrical conduit or connection. Install the restraints in accordance with the instructions that come with them. If disconnection of the restraints is necessary, the restraints must be reconnected after the fryer is returned to its original location.
5. Boil out the frypot prior to first use. Refer to the Frypot Boil-Out instructions on page 2-3.

2.3 Power Requirements

⚠ DANGER

The electrical power supply for this appliance must be the same as indicated on the rating and serial number plate located on the inside of the fryer door.

⚠ DANGER

This appliance must be connected to the voltage and phase specified on the rating and serial number plate located inside the fryer door.

⚠ DANGER

All wiring connections for this appliance must be made in accordance with the wiring diagrams furnished with the equipment. Wiring diagrams are located inside the fryer door.

⚠ DANGER

Copper wire suitable for at least 194°F (90°C) must be used for power connections.

FRYPOT SIZE	VOLTS/KW	PHASE	WIRE SERVICE	MINIMUM WIRE SIZE		120 V CONTROL S & FILTER	AMPS PER LEG		
				AWG	mm ²		L1	L2	L3
110 LB	208/21.5	3	3	3	26.6	N/A	59.7	66.7	66.7
	240/28.6	3	3	3	26.6	N/A	68.8	75.5	75.5
	480/28.6	3	3	6	13.3	11 AMPS	34.4	34.4	34.4
160 LB	208/21.6	3	3	3	33.6	N/A	60.0	67.0	67.0
	240/28.7	3	3	3	33.6	N/A	69.0	76.0	76.0
	480/35.7	3	3	6	13.3	11 AMPS	42.9	42.9	42.9

2.4 Frypot Boil-Out

Before the fryer is first used for cooking product, it should be boiled out to ensure that residue from the manufacturing process has been eliminated.

After the fryer has been in use for a period of time, a hard film of caramelized cooking oil will form inside the frypot. This film should be periodically removed by following the boil-out procedure.

Clean each frypot as follows before filling with cooking oil for the first time and at least once a month thereafter:

1. Before switching the fryer "ON", close the drain valve and fill the frypot with a mixture of cold water and detergent to the bottom oil level line. Follow the detergent manufacture's instructions when mixing.
2. Press the ON/OFF switch  to the "ON" position.

3. Program the computer for boil-out operation as outlined in the separate computer/controller manual provided with the fryer.
4. Simmer the solution for 45 minutes to 1 hour. Do not allow water level to drop below the bottom OIL LEVEL line in frypot during boil-out operation.

⚠ CAUTION

Do not leave the fryer unattended. The boil-out solution may foam and overflow. Place the ON/OFF switch to the "OFF" position to control boil over.

⚠ CAUTION

Do not drain water or boil-out solution into the filter pan or filter system. Irreversible damage will result if water is allowed into the filtration system and all applicable warranties will be voided.

5. Press the ON/OFF switch  to the "OFF" position (the LED displays on the computer go dark).
6. Add two gallons of water. Drain out the solution and clean the frypot thoroughly.
7. Refill the frypot with clean water. Rinse the frypot twice, drain and wipe it down with a clean towel. Remove all traces of water prior to filling frypot with oil.

⚠ DANGER

All drops of water must be removed from frypot before filling with cooking oil.

2.5 Equipment Start-up and Shutdown Procedures

⚠ WARNING

Fill the frypot to the bottom OIL LEVEL line with cooking oil before pressing the ON/OFF switch  to the "ON" position. Failure to do so could damage the frypot.

START-UP AND OPERATION

The 2836 Series fryer has two different sized frypots. The smaller frypot holds 110 pounds of cooking oil or shortening and is heated by three elements having a combined wattage of approximately 28 kilowatts. The larger frypot holds 160 pounds of cooking oil or shortening and is heated by three elements having a combined wattage of approximately 30 kilowatts. The smaller frypot is also equipped with basket lifts that automatically raise the cooking baskets from the frypot at the end of the programmed frying time.

Except for filtering, covered in Chapter 4, operation of the fryer is controlled through its CM III.5 computer. Refer to the separate computer/controller manual furnished with the fryer for details on programming and using the computer.

1. Fill the frypot with cooking oil to the ***bottom*** OIL LEVEL line located on the rear of the frypot. This will allow for oil expansion as heat is applied. Do not fill cold oil any higher than the ***middle*** line. The smaller of the two frypots holds 110 pounds of cooking oil or shortening; the larger frypot holds 160 pounds.

If solid shortening is used, first raise the elements, then pack solid shortening into the bottom of the frypot. Lower the elements, and then pack solid shortening around and over the elements. **Never** insert a solid block of shortening into frypot on top of the elements. Hot spots and element damage will occur, and the potential for flash-fire increases.

 **DANGER**

NEVER set a complete block of solid shortening on top of heating elements. Doing so will damage the elements and increase the potential for flash-point shortening temperatures and subsequent fire.

2. Ensure that the power cords are plugged into the appropriate receptacles. Verify that the faces of the plugs are flush with the outlet plate, with no portion of the prongs visible.
3. Press the ON/OFF switch  to the "ON" position and allow the cooking oil or shortening to reach the programmed cooking temperature. (Refer to the separate computer/controller manual provided with the fryer for details of programming and using the controller.) ***If solid shortening is used***, the MELT CYCLE must be used to melt the shortening. DO NOT DISABLE OR CANCEL THE MELT CYCLE!
4. Ensure that the oil level is at but not above the ***top*** OIL LEVEL line. It may be necessary to add oil or shortening to bring the level up to the proper mark *after the oil has reached the programmed cooking temperature.*
5. Once the oil in the frypot has reached the programmed cooking temperature and the oil level has been verified to be at the ***top*** OIL LEVEL line, the unit is ready for frying.

SHUTDOWN

1. Press the ON/OFF switch  to the "OFF" position (the LED displays on the computer go dark).
2. Filter the cooking oil (if applicable) and clean the fryer (See Chapter 3).
3. Place the frypot covers on frypots.

2836 SERIES ELECTRIC FRYERS

CHAPTER 3: PREVENTATIVE MAINTENANCE

3.1 Cleaning Fryer

3.1.1 Clean Inside and Outside of Fryer Cabinet – Daily

1. Clean inside the fryer cabinet with a dry, clean cloth. Wipe all accessible metal surfaces and components to remove accumulated oil and dust.
2. Clean outside the fryer cabinet, with a clean, damp cloth soaked with dishwashing detergent. Wipe with a clean, damp cloth.

Notes on Care of Stainless Steel

All stainless steel fryer outer parts should be wiped regularly with hot, soapy water during the day and with a liquid cleaner designed for this material at the end of each day.

Do not use steel wool, abrasive cloths, cleansers or powders!

Do not use a metal knife, spatula or any other metal tool to scrape stainless steel! Scratches are almost impossible to remove.

If it is necessary to scrape the stainless steel to remove any encrusted materials, soak the area first to loosen the material, then use a wooden or nylon scraper only.

3.1.1.2 Clean Float Switch Assembly - Daily

Cleaning of the float switch assembly is critical for proper operation of the fryer. To clean the assembly see Section 4.3.2 Filter Operation.

3.1.2 Clean Frypot and Heating Elements – Weekly

WARNING

NEVER operate the fryer(s) with an empty frypot. Irreparable damage to the heating elements will result.

3.1.3 Clean Detachable Parts and Accessories – Weekly

Wipe all detachable parts and accessories with a clean, dry cloth. Use a clean cloth saturated with detergent to remove accumulated carbonized oil on detachable parts and accessories. Rinse the parts and accessories thoroughly with clean water and wipe dry before reinstalling.

3.1.4 Boil Out the Frypot – Monthly

See Section 2.4 for the Boil-Out procedure. For computer/controller operational procedures, consult the separate computer/controller manual provided with the fryer.

3.1.5 Draining and Manual Filtering of Fryers Without Built-in Filtration

For frying systems with built-in filtration, refer to Chapter 4.

If your fryer is not equipped with a built-in filtration system [Under Fryer Filter (UFF)], the cooking oil or shortening must be drained into another suitable container. (For safe, convenient draining and disposal of used cooking oil or shortening, Frymaster recommends using the Frymaster *Shortening Disposal Unit* (SDU). The SDU is available through your local distributor.)

1. Press the ON/OFF switch  to the "OFF" position (the LED displays on the computer go dark). Screw the drainpipe provided with your fryer into the drain valve. Make sure the drainpipe is firmly screwed into the drain valve and that the opening is pointing down.
2. Position a metal container under the drainpipe. The metal container must be able to withstand the heat of the cooking oil and have a sealing lid. If you intend to reuse the oil or shortening, Frymaster recommends that a Frymaster filter cone holder and filter cone be used when a filter machine is not available. If you are using a Frymaster filter cone holder, be sure that the cone holder rests securely on the metal container.

 **DANGER**

Allow oil to cool to 100°F (38°C) or lower before draining into an appropriate container for disposal.

3. Open the drain valve slowly to avoid splattering. If the drain valve becomes clogged with food particles, use the Fryer's Friend (clean-out rod) to clear the blockage.

 **DANGER**

DO NOT insert anything into the drain from the front to unclog the valve. Hot oil will rush out, creating an extreme hazard.

 **WARNING**

DO NOT hammer on the drain valve with the Fryer's Friend. This will damage the drain valve ball and prevent the valve from sealing securely, resulting in a leaky valve.

4. After draining the oil, clean all food particles and residual oil from the frypot. **BE CAREFUL**, this material may still cause severe burns if it comes in contact with bare skin.
5. Close the drain valve securely and fill the frypot with clean, filtered or fresh cooking oil or solid shortening to the bottom **OIL LEVEL** line.

3.2 Periodic/Annual Maintenance

Frymaster **recommends** that the fryer be inspected annually by a **Factory Authorized Service Technician** for the following checks and adjustments:

- Inspect the cabinet inside and out, front and rear for excessive oil build-up and/or oil migration.
- Verify that the heating element wires are in good condition and that leads have no visible fraying or insulation damage and that they are free of oil migration build-up.
- Verify that heating elements are in good condition with no carbon/caramelized oil build-up. Inspect the elements for signs of extensive dry-firing.
- Verify that the tilt mechanism is working properly when lifting and lowering elements, and that the element wires are not binding and/or chafing.
- Verify the heating-element amp-draw is within the allowed range as indicated on the appliance's rating plate.
- Verify that the temperature and high-limit probes are properly connected, tightened and functioning properly, and that mounting hardware and probe guard are present and properly installed.
- Verify that component box and contactor box components (i.e. computer/controller, relays, interface boards, transformers, contactors, etc.) are in good condition and free from oil migration build-up and other debris.
- Verify that component box and contactor box wiring connections are tight and that wiring is in good condition.
- Verify that all safety features (i.e. contactor shields, drain safety switches, reset switches, etc.) are present and functioning properly.
- Verify that the frypot/cookpot is in good condition and free of leaks and that the frypot/cookpot insulation is in serviceable condition.
- Verify that all wiring harnesses and connections are tight and in good condition.

Built-in Filtration:

- Inspect all oil-return and drain lines for leaks and verify that all connections are tight.
- Inspect the filter pan for leaks and cleanliness. If there is a large accumulation of crumbs in the crumb basket, advise the owner/operator that the crumb basket should be emptied into a fireproof container and cleaned daily.

- Verify that all O-rings and seals (including those on quick-disconnect fittings) are present and in good condition. Replace O-rings and seals if worn or damaged.
- Check filtration system integrity as follows:
 - With the filter pan empty, place each oil return handle, one at a time, in the ON position. Verify that the pump activates and that bubbles appear in the cooking oil of the associated frypot.
 - Close all oil return valves (i.e., place all oil return handles in the OFF position). Verify proper functioning of each oil return valve by activating the filter pump using the lever on one of the oil return handle microswitches. No air bubbles should be visible in any frypot.
 - Verify that the filter pan is properly prepared for filtering, then drain a frypot of oil heated to 350°F (177°C) into the filter pan and close the frypot drain valve. Place the oil return handle in the ON position. Allow all cooking oil to return to the frypot (indicated by bubbles in the cooking oil). Return the oil return handle to the OFF position. The frypot should refill in no more than 10 minutes.

To ensure good fryer health and a safe environment, the fryer should be checked and adjusted periodically by qualified service personnel as part of a regular kitchen maintenance program.

2836 SERIES ELECTRIC FRYERS

CHAPTER 4: BUILT-IN FILTRATION

4.1 Preparing the Filter System for Use

After initial installation and before each use, remove all loose parts from the filter, wash the filter pan and all accessories in hot, soapy water and dry thoroughly.

4.1.1 Assembling the Filter

The Under Fryer Filter (UFF) installed in this series uses filter paper, held in place by a hold-down ring, to filter impurities and debris from the cooking oil. The filter pan consists of the following components:

1. Filter pan.
2. Filter grid.
3. Filter paper.
4. Hold-down ring.
5. Crumb screen.

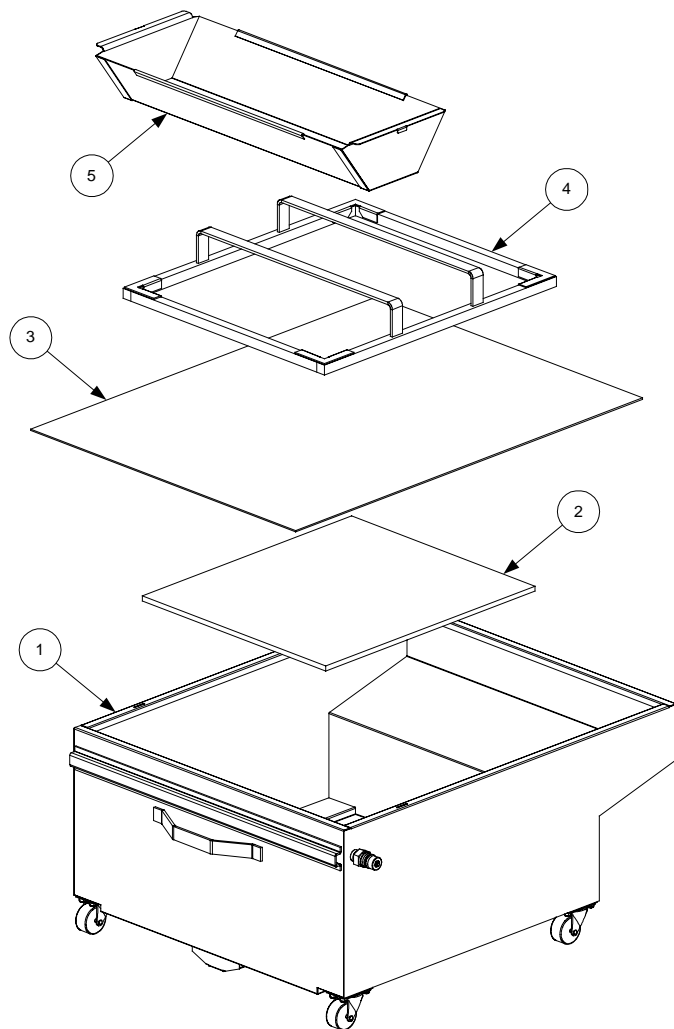

4.2 Daily Filter Operation

WARNING

Use caution and wear proper protective clothing whenever filtering. The oil to be filtered is at or near 350°F (175°C). Ensure all hoses are connected properly and drain handles are in their proper position prior to operating any switches or valves. Failure to do this can result in severe burns.

WARNING

Drawings and photos used in this manual are intended to illustrate operational, cleaning and technical procedures and may not conform to on-site management policies and/or operational procedures.

4.2.1 General Overview

The filter pump is turned on only after the oil is brought to operating temperature and drained into the prepared filter pan. The filter motor is then engaged and oil is drawn through filter paper and pumped back into the frypot. The frypot drain valve remains open during the filtering process. Allow the oil to cycle through the filter paper for approximately 5 minutes. At the end of 5 minutes, close the drain valve and allow the pump to fill the frypot to the bottom OIL LEVEL line. Leave the pump running for 10-15 seconds after bubbles appear in the frypot to ensure all oil is pumped from the drain pan and the lines.

4.2.2 Filtering Tools

Assemble the tools needed for filtering. These are supplied with the filter starter kit included with the fryer/filter system:

- Frypot/Filter Brush - used to clean frypot and filter pan sides and bottom, heating elements, and to dislodge sediment during filtration or oil change.
- Clean-Out Rod (design may vary)- used to dislodge heavy debris in the drain tube (when needed).
- Filter Powder.
- Filter Paper.
- Disposal hose.

The following tools are not required, but are recommended to make the filtering task easier.

- Measuring Cup — used to measure filter powder.
- Stainless Steel Crumb Scoop — for removing large debris.

NOTE: Always wear oil-resistant, insulated gloves and/or protective gear when working with hot oil.

4.3 Operating the Filter

4.3.1 Pan Preparation

1. Disconnect the suction hose from the filter assembly by grasping the quick-disconnect collar on the hose and pulling it away from the filter pan and off the quick-disconnect fitting on the pan.

Allow any residual oil left in the hose to drain into the pan, then pull the filter pan straight out from the fryer cabinet.

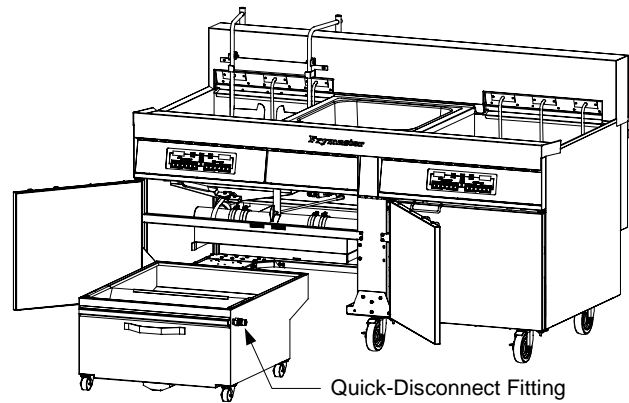

2. Remove the crumb screen, hold-down ring, filter paper, and filter grid from the pan. Dispose of the filter paper, clean all other components in hot, soapy water and dry thoroughly. Clean the pan and sump, ensuring the air hole in the pickup (suction) tube is clear of debris.

3. Place the filter grid in the bottom of the pan and lay one sheet of filter paper over the grid. Lower the hold-down ring over the paper and grid so that the paper folds up around the outer edges of the ring.

Sprinkle one 8-ounce cup of filter powder evenly over the filter paper.

Install the crumb screen, being sure that it is positioned all the way to the front of the pan so that the tabs on its ends engage the slots in the filter pan.

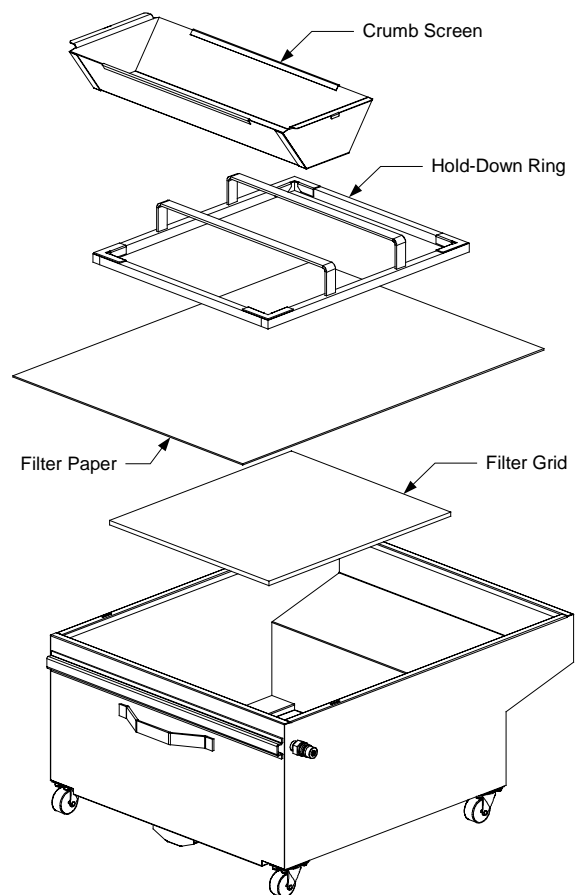

4. Inspect the O-ring on the quick-disconnect fitting and replace if worn or damaged.

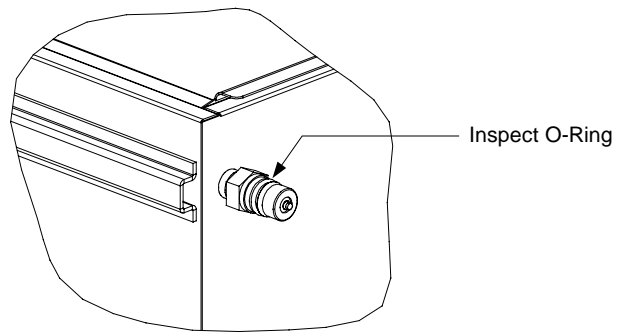

5. Push the prepared filter pan back into the fryer cabinet and reconnect the suction hose to the pan.

4.3.2 Filter Operation

⚠ CAUTION
NEVER operate the filter unit unless cooking oil is at operating temperature (~350°F).

1. Ensure the filter pan assembly is prepared as described in Section 4.3.1.
2. Turn fryer off and remove the fry baskets from the frypot. Prior to filtering, skim any large debris from the oil. Use extreme caution, as oil is at or near operating temperature (350°F).

3. After ensuring the filter pan is correctly positioned under the drain tubes, open the drain valve to drain the frypot into the filter pan. **DRAIN ONLY ONE FRYPOT AT A TIME!** The filter pan is designed to hold the contents of one frypot only.

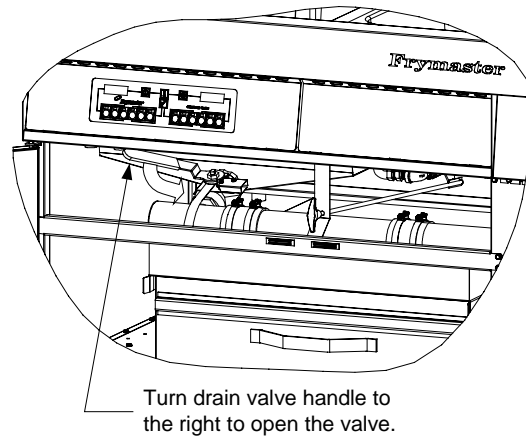

4. After the frypot is completely drained into the filter pan, remove the acorn nut and cover from the float switch assembly. This assembly is located in the rear of the frypot on a 28 frypot and in the corner of the 36 frypot as indicated by the photo to the right.

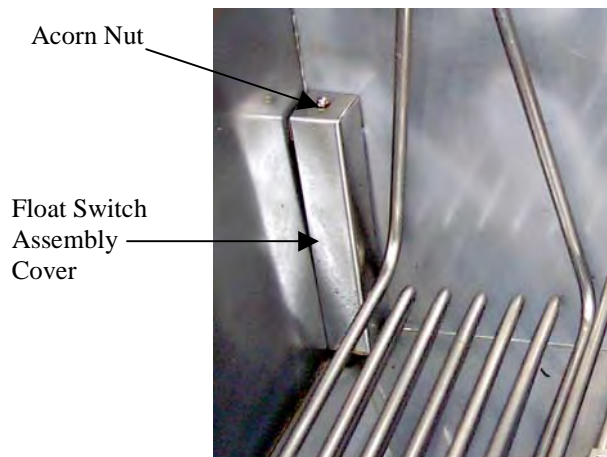

- Clean crumbs and sediment around the float for proper operation. Reattach the float switch cover. It is important that this be done during every filtering process for proper operation of the fryer.

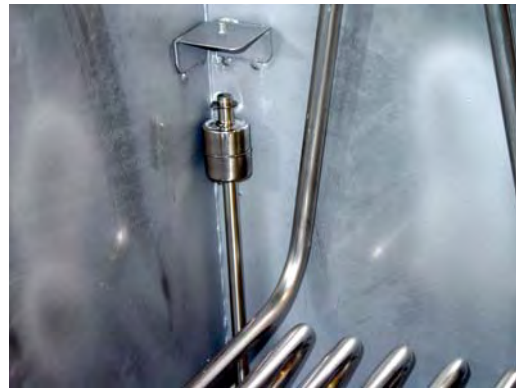

- After cleaning the float switch and all oil has drained from the frypot into the filter pan, pull the filter pump T-handle to open the oil return valve and activate the filter pump.

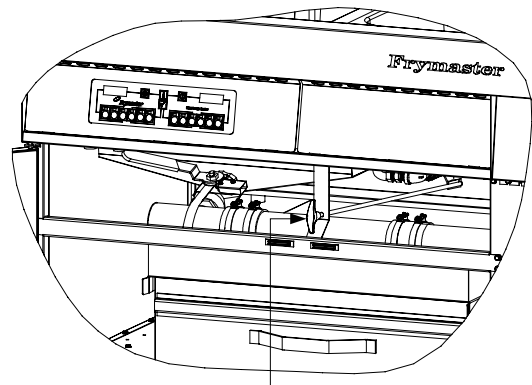

Pull the T-handle out to start the filter pump.

- Oil will begin to pump from the filter pan into the frypot. Allow the oil to circulate for approximately 5 minutes to remove suspended particles. If the frypot sides and bottom have sediment deposits, lift the heating elements and clean the frypot with the cleaning brush included with the fryer.
- After the oil is filtered, close the drain valve and allow the frypot to refill.
- After all oil is pumped back into the frypot, bubbles will form, indicating air in the oil return lines. Allow the oil to bubble for 10-15 seconds to ensure all the oil is evacuated from the return lines. Push the T-handle in to close the oil return valve and deactivate the filter pump.
- If the oil level is low, add oil until the level is at the top OIL LEVEL line.
- Turn the fryer on and allow the oil to reach the programmed frying temperature.

4.3.3 Oil Disposal

- Ensure the filter pan assembly is prepared as described in Section 4.3.1. **It's imperative, even when draining oil for disposal, that filter paper and the crumb basket are in place. Debris in old oil can clog the filter system.**

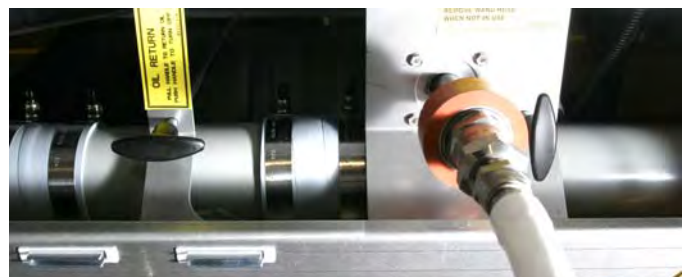

The handle (right above) next to the oil-disposal quick-disconnect activates the filter pump. All drain valves should be closed when oil is being pumped out for disposal.

2. Turn fryer off and remove the fry baskets from the frypot. Prior to draining, skim any large debris from the oil. Use extreme caution, as oil is at or near operating temperature (350°F).
3. After ensuring the filter pan is correctly positioned under the drain tubes, open the drain valve to drain the frypot into the filter pan. **DRAIN ONLY ONE FRYPOT AT A TIME!** The filter pan is designed to hold the contents of one frypot only.
4. Ensure all drain valves are closed.
5. Attach the disposal hose to the quick-disconnect in the fryer cabinet.
6. Direct the hose into a metal receptacle suitable for holding 350°F oil. Use caution and wear protective clothing. Hot oil can cause serious injury.
7. Pull the handle adjacent to the quick-disconnect, which starts the filter pump.
8. Oil will flow from the filter pan to the disposal receptacle.
9. When the flow is reduced to a sputter, shut the filter pump off by pushing the handle back into place.
10. Dispose of the exhausted oil and drain any other frypots of exhausted oil following the steps above.
11. Clean and refill the drained frypots with oil to the lower of the etched lines in the frypots. Note it is recommended that frypots be boiled out with each change of oil. Boil out is covered in Section 2.4.

 **DANGER**

The crumb tray in fryers equipped with a filter system must be emptied into a fireproof container at the end of frying operations each day. Some food particles can spontaneously combust if left soaking in certain shortening material.

 **WARNING**

Do not bang fry baskets or other utensils on the fryer's joiner strip. The strip is present to seal the joint between the frypots. Banging fry baskets on the strip to dislodge shortening will distort the strip, adversely affecting its fit. It is designed for a tight fit and should only be removed for cleaning.

2836 SERIES ELECTRIC FRYERS

CHAPTER 5: OPERATOR TROUBLESHOOTING

5.1 Introduction

This section provides an easy reference guide to some of the common problems that may occur during the operation of this equipment. The troubleshooting guides that follow are intended to help correct, or at least accurately diagnose, problems with this equipment. Although the chapter covers the most common problems reported, you may encounter problems that are not covered. In such instances, the Frymaster Technical Services staff will make every effort to help you identify and resolve the problem.

When troubleshooting a problem, always use a process of elimination starting with the simplest solution and working through to the most complex. Never overlook the obvious – anyone can forget to plug in a cord or fail to close a valve completely. Most importantly, always try to establish a clear idea of why a problem has occurred. Part of any corrective action involves taking steps to ensure that it doesn't happen again. If a controller malfunctions because of a poor connection, check all other connections, too. If a fuse continues to blow, find out why. Always keep in mind that failure of a small component may often be indicative of potential failure or incorrect functioning of a more important component or system.

Before calling a service agent or the Frymaster/Dean HOTLINE (1-800-551-8633):

- **Verify that electrical cords are plugged in and that circuit breakers are on.**
- **Verify that frypot drain valves are fully closed.**

When calling the Frymaster/Dean hotline, make sure you have the model number, serial number, and voltage of the fryer written down. This information is found on the rating plates affixed to the inside face of the fryer doors.

 **DANGER**

Hot cooking oil/shortening will cause severe burns. Never attempt to move this appliance when filled with hot cooking oil/shortening or to transfer hot cooking oil/shortening from one container to another.

 **DANGER**

This equipment should be unplugged when servicing, except when electrical circuit tests are required. Use extreme care when performing such tests.

This appliance may have more than one electrical power supply connection point. Disconnect all power cords before servicing.

Inspection, testing, and repair of electrical components should be performed by an authorized service agent only.

5.2 Troubleshooting

5.2.1 Control and Heating Problems

Problem	Probable Causes	Corrective Action
Controller won't activate.	A. Power cord is not plugged in or circuit breaker is tripped.	A. Plug power cord in and verify that circuit breaker is not tripped.
	B. Controller has failed.	B. Call FASC.
Fryer does not heat.	A. Drain valve is open.	A. This fryer is equipped with a drain safety switch that prevents the heating elements from being energized if the drain valve is not fully closed. Verify that the drain valve is fully closed.
	B. Controller has failed.	B. Call FASC.
Fryer repeatedly cycles on and off when first started.	Fryer is in melt-cycle mode.	This is normal for fryers equipped with <i>CM III computers</i> . The default operational mode for these computers is for the elements to cycle on and off until the temperature in the frypot reaches 180°F (82°C). CYCL will appear in the display when in the melt-cycle mode. The purpose of the melt-cycle is to allow controlled melting of solid shortening to prevent scorching and flash fires or damage to the elements. If you are not using solid shortening, the melt-cycle can be cancelled or bypassed. Refer to the separate <i>Frymaster Fryer Controllers User's Manual</i> for the procedure for canceling the melt-cycle.
Fryer does not heat after filtering.	Drain valve is open.	This fryer is equipped with a drain safety switch that prevents the heating elements from being energized if the drain valve is not fully closed. Verify that the drain valve is fully closed.
Fryer heats until high-limit trips with heat indicator ON.	Temperature probe or controller has failed.	Call FASC.
Fryer heats until high-limit trips without heat indicator ON.	Contact or controller has failed.	Call FASC.

Problem	Probable Causes	Corrective Action
Fryer stops heating with heat indicator ON.	The high-limit thermostat or contactor has failed.	The fact that the heat indicator is ON indicates that the controller is functioning properly and is calling for heat. The high-limit thermostat functions as a normally closed switch. If the thermostat fails, the "switch" opens and power to the elements is shut off. If the contactor fails to close, no power is supplied to the elements. Determining which component has failed is beyond the scope of operator troubleshooting. Call FASC.

5.2.2 Error Messages and Display Problems

Problem	Probable Causes	Corrective Action
Display is in wrong temperature scale (Fahrenheit or Celsius).	Incorrect display option programmed.	CM III computers may be programmed to display in either Fahrenheit or Celsius. Refer to the separate <i>Frymaster Fryer Controllers User's Manual</i> for instructions on <u>changing the display</u> .
Display shows <i>HELP</i>.	Open drain valve or problem with latching circuitry.	Verify that the drain valve is fully closed. The fryer will not function if the drain valve is not fully closed. If the drain valve is fully closed, the problem is within the latching circuitry and is beyond the scope of operator troubleshooting. Call FASC.
Display shows <i>HI</i>.	Fryer is more than 21°F (12°C) above setpoint.	This display is normal if the fryer setpoint has been changed to a lower temperature. The display should revert to the normal four dashes when the frypot temperature cools to the setpoint. If the setpoint has not been changed, this indicates a problem with the temperature control circuitry. Turn the fryer off and call FASC.
Display shows <i>HOT</i>.	Frypot temperature is more than 410°F (210°C) or, in CE countries, 395°F (202°C).	This is an indication of a malfunction in the temperature control circuitry, including a failure of the high-limit thermostat. Shut the fryer down immediately and call FASC.

Problem	Probable Causes	Corrective Action
Display shows <i>Lo</i>.	Frypot temperature is more than 21°F (12°C) below setpoint.	This display is normal when the fryer is first turned on and may appear for a short while if a large batch of frozen product is added to the frypot. If the display never goes out, the fryer is not heating. Look for a decimal in the LED display between digits 1 and 2. If the decimal is present, the computer is calling for heat and is functioning properly. See <i>Fryer Does Not Heat</i> in Control and Heating Problems (Section 5.2.1). If the decimal is not present, the computer is not calling for heat and may be malfunctioning. Turn the fryer off and call FASC.
Display shows <i>Prob.</i>	Problem with the temperature measuring circuitry including the probe.	This indicates a problem within the temperature measuring circuitry that is beyond the scope of operator troubleshooting. Shut the fryer down and call FASC.
Frypot temperature is displayed constantly.	Computer is programmed for constant temperature display.	The CM III computer may be programmed for constant temperature display or countdown timer display. Refer to the separate <i>Frymaster Fryer Controllers User's Manual</i> for instructions on toggling between these display options.

5.2.3 Basket Lift Problems

Problem	Probable Causes	Corrective Action
Basket lift movement is noisy, jerky, or erratic.	Lack of lubrication on basket lift rods.	Apply a light coating of Lubriplate or similar lightweight white grease to the rod and bushings.

5.2.4 Built-in Filtration Problems

Problem	Probable Causes	Corrective Action
<p>Filter pump won't start.</p>	<p>A. Power cord is not plugged in or circuit breaker is tripped.</p>	<p>A. Verify that the power cord is fully plugged in. If so, verify that circuit breaker is not tripped.</p>
	<p>B. Pump motor has overheated causing the thermal overload switch to trip.</p>	<p>B. If the motor is too hot to touch for more than a few seconds, the thermal overload switch has probably tripped. Allow the motor to cool at least 45 minutes then press the Pump Reset Switch.</p>
	<p>C. Blockage in filter pump.</p> <p>Test: Close the drain valve and pull the filter pan out from the fryer. Activate the pump. If the pump motor hums for a short time then stops, the probable cause is blockage of the pump itself.</p>	<p>C. Pump blockages are usually caused by sediment buildup in the pump due to improperly sized or installed filter paper and failure to use the crumb screen. Call FASC.</p>



Welbilt offers fully-integrated kitchen systems and our products are backed by KitchenCare[®] aftermarket parts and service. Welbilt's portfolio of award-winning brands includes Cleveland[™], Convothem[®], Crem[®], Delfield[®], Frymaster[®], Garland[®], Kolpak[®], Lincoln[®], Merco[®], Merrychef[®] and Multiplex[®].

Bringing innovation to the table • welbilt.com