



35 Series Gas Fryers

Service & Parts Manual



FRYMASTER®



Frymaster, a member of the Commercial Food Equipment Service Association, recommends using CFESA Certified Technicians.

24-Hour Service Hotline 1-800-551-8633



09/2022

NOTICE

IF, DURING THE WARRANTY PERIOD, THE CUSTOMER USES A PART FOR THIS FRYMASTER DEAN EQUIPMENT OTHER THAN AN **UNMODIFIED** NEW OR RECYCLED PART PURCHASED DIRECTLY FROM FRYMASTER DEAN, OR ANY OF ITS AUTHORIZED SERVICE CENTERS, AND/OR THE PART BEING USED IS MODIFIED FROM ITS ORIGINAL CONFIGURATION, THIS WARRANTY WILL BE VOID. FURTHER, FRYMASTER DEAN AND ITS AFFILIATES WILL NOT BE LIABLE FOR ANY CLAIMS, DAMAGES OR EXPENSES INCURRED BY THE CUSTOMER WHICH ARISE DIRECTLY OR INDIRECTLY, IN WHOLE OR IN PART, DUE TO THE INSTALLATION OF ANY MODIFIED PART AND/OR PART RECEIVED FROM AN UNAUTHORIZED SERVICE CENTER.

NOTICE

This appliance is intended for professional use only and is to be operated by qualified personnel only. A FRYMASTER DEAN Factory Authorized Servicer (FAS) or other qualified professional should perform installation, maintenance, and repairs. Installation, maintenance, or repairs by unqualified personnel may void the manufacturer's warranty. See Chapter 1 of this manual for definitions of qualified personnel.

NOTICE

This equipment must be installed in accordance with the appropriate national and local codes of the country and/or region in which the appliance is installed. See NATIONAL CODE REQUIREMENTS in Chapter 2 of this manual for specifics.

NOTICE TO U.S. CUSTOMERS

This equipment is to be installed in compliance with the basic plumbing code of the Building Officials and Code Administrators International, Inc. (BOCA) and the Food Service Sanitation Manual of the U.S. Food and Drug Administration.

NOTICE

Drawings and photos used in this manual are intended to illustrate operational, cleaning and technical procedures and may not conform to onsite management operational procedures.

NOTICE TO OWNERS OF UNITS EQUIPPED WITH COMPUTERS

U.S.

This device complies with Part 15 of the FCC rules. Operation is subject to the following two conditions: 1) This device may not cause harmful interference, and 2) This device must accept any interference received, including interference that may cause undesired operation. While this device is a verified Class A device, it has been shown to meet the Class B limits.

CANADA

This digital apparatus does not exceed the Class A or B limits for radio noise emissions as set out by the ICES-003 standard of the Canadian Department of Communications.

Cet appareil numerique n'emet pas de bruits radioelectriques depassany les limites de classe A et B prescrites dans la norme NMB-003 edictee par le Ministre des Communcations du Canada.

 DANGER

Improper installation, adjustment, maintenance or service, and unauthorized alterations or modifications can cause property damage, injury, or death. Read the installation, operating, and service instructions thoroughly before installing or servicing this equipment. Only qualified service personnel may convert this appliance to use a gas other than that for which it was originally configured.

⚠ DANGER

No structural material on the fryer should be altered or removed to accommodate placement of the fryer under a hood. Questions? Call the Frymaster Dean Service Hotline at 1-800-551-8633.

⚠ DANGER

Adequate means must be provided to limit the movement of this appliance without depending upon the gas line connection. Single fryers equipped with legs must be stabilized by installing anchor straps. All fryers equipped with casters must be stabilized by installing restraining chains. If a flexible gas line is used, an additional restraining cable must be connected at all times when the fryer is in use.

⚠ DANGER

The front ledge of the fryer is not a step! Do not stand on the fryer. Serious injury can result from slips or contact with the hot oil.

⚠ DANGER

Do not store or use gasoline or other flammable liquids or vapors in the vicinity of this or any other appliance.

⚠ DANGER

Instructions to be followed in the event the operator smells gas or otherwise detects a gas leak must be posted in a prominent location. This information can be obtained from the local gas company or gas supplier.

⚠ DANGER

This product contains chemicals known to the state of California to cause cancer and/or birth defects or other reproductive harm.

Operation, installation, and servicing of this product could expose you to airborne particles of glasswool or ceramic fibers, crystalline silica, and/or carbon monoxide. Inhalation of airborne particles of glasswool or ceramic fibers is known to the State of California to cause cancer. Inhalation of carbon monoxide is known to the State of California to cause birth defects or other reproductive harm.

35 SERIES GAS FRYERS

TABLE OF CONTENTS

CHAPTER 1: Service Procedures

1.1	Functional Description.....	1-1
1.2	Accessing Fryer for Servicing	1-2
1.3	Cleaning the Gas Valve Vent Tube	1-2
1.4	Checking Burner Manifold Pressure.....	1-2
1.5	Adjusting Burner Ceramic Target Spacing and Alignment.....	1-2
1.6	Adjusting Pilot Flame	1-3
1.7	Calibrating Thermostat Control	1-3
1.8	Replacing Fryer Components	1-5
1.8.1	Replacing the Operating Thermostat in Standard MJ35 Fryers.....	1-5
1.8.2	Replacing the Operating Thermostat in G-Model Fryers	1-5
1.8.3	Replacing the High-Limit Thermostat in Standard MJ35 Fryers	1-6
1.8.4	Replacing the High-Limit Thermostat in G-Model Fryers	1-6
1.8.5	Replacing Burner Ceramic Targets.....	1-7
1.8.6	Replacing the Gas Valve.....	1-8
1.8.7	Replacing Pilot Assembly or Thermopile.....	1-8
1.8.8	Replacing the Frypot.....	1-10
1.9	Troubleshooting and Problem Isolation.....	1-11
1.9.1	Pilot Failures	1-12
1.9.2	Problems Related to the Gas and/or Electrical Current	1-12
1.9.3	Problems Related to the Electrical Circuits	1-13
1.9.4	Problems Related to the Gas Valve	1-13
1.9.5	Improper Burner Functioning	1-14
1.9.6	Improper Temperature Control.....	1-15
1.9.7	Filtration Problems.....	1-15
1.9.8	Leakage	1-17
1.9.9	Basket Lift Malfunctions	1-17
	Binding/Jamming Problems.....	1-18
	Motor Problems	1-18
	Electrical Problems	1-18
	Bell Crank Basket Lift Wiring Diagram.....	1-18
1.10	Probe Resistance Chart	1-19

CHAPTER 2: Parts List

Accessories	2-1
Basket Lift.....	2-2
Cabinetry.....	2-3
Drain System Components	2-4
Filter Boxes.....	2-6
Filter Pans	2-7
Frypots	2-8
Gas Valves and Burner Components	2-10
Oil Return Plumbing Components.....	2-12
Power Shower and Oil Return Handle Components.....	2-14
Thermostats, Timer, and Related Components.....	2-15

35 SERIES GAS FRYERS

CHAPTER 1: SERVICE PROCEDURES

1.1 Functional Description

The 35 Series fryers contain a welded steel (stainless or cold-rolled) frypot that is directly heated by gas flames that are diffused evenly over its lower surface by ceramic deflectors (targets).

The flames originate from orifices in a U-shaped burner manifold positioned beneath the frypot. The orifice diameters differ for natural and LP gas as indicated in the accompanying table.

35 Series Orifice Sizes (0-1999 ft/609 m)		
Gas	Inches	Millimeters
Natural (G20/25)	0.0669	1.70mm
LP (G31)	0.0413	1.05mm

Gas flow to the manifold is regulated by an electromechanical gas valve. This series of fryers is equipped with a millivolt gas valve and all models use a pilot ignition system.

Pilot Ignition System

The pilot ignition system is made up of the pilot orifice, pilot hood, and a thermopile. The pilot serves two purposes: light the burner and heat the thermopile. In operation, the thermopile is in contact with the pilot flame and generates millivolts. The millivolt output passes through a normally closed high-limit switch and energizes the gas valve pilot coil, which in turn opens the pilot valve. If the pilot flame is extinguished, voltage is lost to the gas valve pilot coil and the pilot valve closes.

Control Options

The temperature control knob on FM/MJ35 fryers is located behind the hinged front panel, out of sight. On FM/MJ35G fryers, the knob is exposed on the face of the front panel. The MJ35G model may be equipped with optional basket lifts. The basket lift option requires an electrical power supply.

Thermostats

Fryers in this series are equipped with an adjustable *controlling (operating) thermostat*. The temperature at which the thermostat opens and closes is adjusted by turning the temperature control knob referenced above. The controlling thermostat used in the 35 Series fryers is sensitive to one-degree changes in temperature.

All 35 Series fryers are equipped with a *high-limit thermostat*. In the event that the fryer fails to properly control the oil temperature, the high-limit thermostat prevents the fryer from overheating to the flash point. The high-limit thermostat acts as a normally closed power switch that opens when exposed to temperatures above 425°F to 450°F (218°C to 232°C). The high-limit thermostat is the same for CE and Non-CE applications, but the terminals for attaching it to the gas valve differ. When a replacement high-limit thermostat is ordered, the terminals for both applications are furnished in the kit.

1.2 Accessing Fryers for Servicing

DANGER

Moving a fryer filled with cooking oil may cause spilling or splattering of the hot liquid. Follow the draining instructions in Chapter 4 of this manual before attempting to relocate a fryer for servicing.

1. Drain shortening from fryer.
2. Shut off the gas supply to the unit. Unplug the power cord(s) if equipped. Disconnect the unit from the gas supply.
3. Remove any attached restraining devices.
4. Relocate the fryer for service accessibility.
5. After servicing is complete, reconnect the unit to the gas supply, reattach restraining devices, and plug in the electrical cords.
6. Refill with shortening.

1.3 Cleaning the Gas Valve Vent Tube

Refer to Semi-Annual Checks and Services in Chapter 5, Preventive Maintenance, of the Installation and Operation Manual (P/N 819-5776).

1.4 Checking the Burner Manifold Gas Pressure

Refer to Semi-Annual Checks and Services in Chapter 5, Preventive Maintenance, of the Installation and Operation Manual (P/N 819-5776).

1.5 Adjusting Burner Ceramic Target Spacing and Alignment

DANGER

Drain the frypot or remove the handle from the drain valve before proceeding further.

Proper spacing of the top edge of the burner ceramic targets is $\frac{3}{4}$ inch (13 mm) from the frypot side. To adjust target spacing, bend the brackets to which they are attached away from or toward the frypot to the proper distance. (A length of board of the proper thickness is useful as a gauge to verify spacing and alignment.)

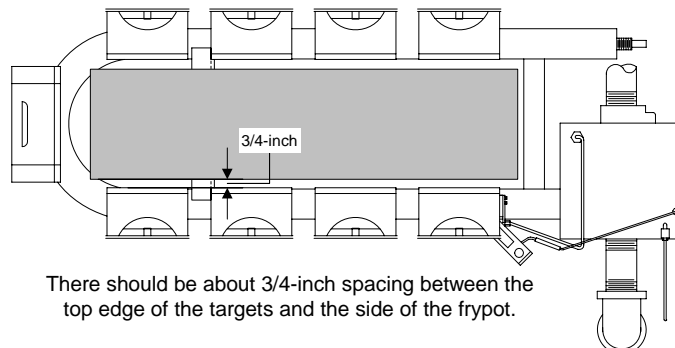

1.6 Adjusting the Pilot Flame

Non-CE Gas Valves

1. For Non-CE Gas Valves, remove the screw from the pilot adjustment screw hole on the gas valve.
2. Using a small, flat-tipped screwdriver, turn the pilot adjustment screw counterclockwise to increase the length of the flame or clockwise to decrease the length of the flame. Adjust flame to a length of 1 to 1½ inches (25 to 38mm).
3. Reinstall the pilot adjustment screw cap.

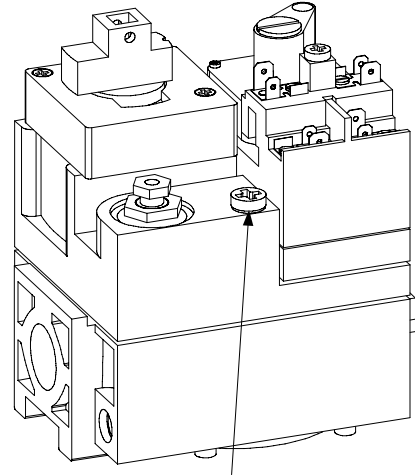

The pilot adjustment screw on the Non-CE Honeywell valve is under this screw.

CE Gas Valves

Using a small, flat-tipped screwdriver, turn the pilot adjustment screw counterclockwise to increase the length of the flame or clockwise to decrease the length of the flame. Adjust flame to a length of 25 to 38mm.

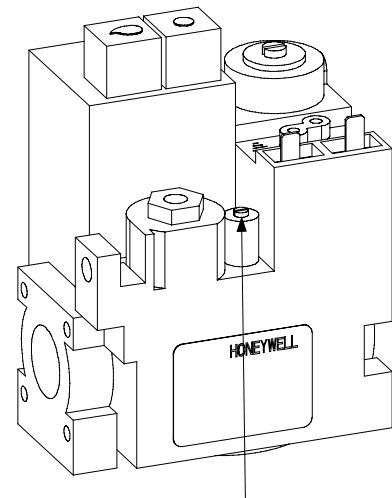

The pilot adjustment on the CE valve is here.

1.7 Calibrating the Thermostat Control

On Standard MJ35 Fryers

1. Fill the frypot to the lower OIL-LEVEL line with cooking oil. If solid shortening is used, it must be tightly packed into the frypot before starting calibration procedure.
2. Light the pilot. (Refer to Chapter 3 of the Installation and Operation Manual, P/N 819-5776 for detailed lighting instructions.)
3. Insert a good grade thermometer or pyrometer into the frypot, about one inch from the thermostat.
4. Set the thermostat to 325°F (162°C).
5. Let the burner cycle on and off three times.

6. Take a pyrometer reading when the burners go off for the third time.
7. Loosen the setscrews in the thermostat knob and turn knob to the temperature established by the pyrometer reading.
8. Allow burners to cycle on and off three more times and recheck pyrometer reading against thermostat setting. Temperature readings should be within 5°F (2°C).

On G-Model Fryers

1. Fill the frypot to the lower OIL-LEVEL line with cooking oil. If solid shortening is used, it must be tightly packed into the frypot.
2. Light the pilot. (Refer to Chapter 3 of the Installation and Operation Manual, P/N 819-5776, for detailed lighting instructions.)
3. Insert a good grade thermometer or pyrometer into the frypot, about one inch from the thermostat.
4. Set the thermostat to 325°F (162°C).
5. Allow the burners to cycle on and off three times. Compare the reading of the pyrometer to the setting on the thermostat plate. The position of the knob on the thermostat and the reading from the pyrometer should be within 5°F (2°C) of each other.
6. If not, loosen the setscrew and stop screw securing the thermostat shaft extension to the flexible shaft. Remove the extension to expose the slot in the end of the flexible shaft. Use a flatblade screwdriver to adjust the thermostat.
7. When the cooking oil temperature reaches 325°F (162°C), turn the flexible shaft slowly **clockwise** until the burner shuts off. (Turning the shaft counterclockwise causes the burner to light; turning it clockwise causes it to shut off.)
8. Allow the fryer to sit for a few minutes, then slowly turn the flexible shaft **counterclockwise** until the burner lights.
9. Repeat steps 6 and 7 at least three times to ensure an accurate setting is obtained. The thermostat control is considered to be properly calibrated if the burner lights as the cooking oil cools to 325°F (162°C)—not when the burner shuts off as the temperature rises.
10. Once the calibration point of 325°F (162°C) is determined, allow the burner to cycle on and off at least three times to be sure it will light at the calibrated temperature.
11. Carefully replace the thermostat shaft extension, ensuring that the stop screw is pointed straight up. Tighten the stop screw and locking nut and the setscrew, being careful not to rotate the flexible shaft.

 **CAUTION**

The thermostat flexible shaft must not be rotated while installing the thermostat shaft extension.

12. Close the fryer control panel and replace the screws in the upper corners.
13. Reinstall the thermostat knob with its pointer aligned with the 325°F (162°C) index mark on the temperature dial.
14. Reconnect the fryer to the electrical power supply.

1.8 Replacing Fryer Components

1.8.1 Replacing the Operating Thermostat in Standard MJ35 Fryers

1. Drain the fryer and turn the gas off.
2. Use an allen wrench to loosen setscrew at the side of the thermostat knob. Remove the thermostat knob.
3. Remove the two setscrews on either side of the thermostat shaft and remove the dial plate.
4. Disconnect the thermostat wires from gas valve.
5. Use a slotted socket to unscrew the thermostat from the frypot.
6. Apply a small amount of Loctite™ PST56765 compound to the threads of the new thermostat and screw it into the frypot, torquing to 180 inch-pounds.
7. Recalibrate the thermostat (see Section 1.7).



Setscrews hold the knob and dial plate to the thermostat. Use an allen wrench to remove both.

⚠ CAUTION
The operating thermostat must be calibrated after installation is complete. Refer to Section 1.7 for calibration instructions.

1.8.2 Replacing the Operating Thermostat in G-Model Fryers

1. Drain the fryer and turn the gas off.
2. Use an allen wrench to loosen the setscrews on the side of the thermostat knob. Remove the knob and the control panel.
3. Loosen the setscrew attaching the flexible shaft to the thermostat shaft.
4. Remove the two setscrews that hold the flexible shaft bracket in place. Remove the bracket and the shaft.



On G-Model fryers, the shaft connecting the exterior thermostat knob to the frypot-mounted thermostat must be disconnected.

5. Use a slotted socket to unscrew the thermostat from the frypot.
6. Apply a small amount of Loctite™ PST56765 compound to the threads of the new thermostat and screw it into the frypot, torquing to 150 foot-pounds.
7. Recalibrate the thermostat (see Section 1.7).

⚠ CAUTION

The operating thermostat must be calibrated after installation is complete. Refer to Section 1.7 for calibration instructions.

1.8.3 Replacing the High-Limit Thermostat in Standard MJ35 Fryers

1. Drain the fryer and turn the gas off.
2. Disconnect the wires at the gas valve.
3. Use a slotted socket to unscrew the high-limit thermostat from the frypot.
4. Apply a small amount of Loctite™ PST56765 compound to the threads of the new thermostat.



The high-limit thermostat on the standard MJ35 is located below the thermostat dial.

5. Screw the replacement thermostat into the frypot, torquing to 180 inch-pounds.

1.8.4 Replacing the High-Limit Thermostat in G Series Fryers

1. Drain the fryer and turn the gas off.
2. Disconnect basket lift- or filter-equipped fryers from the electrical power supply.
3. Disconnect the thermostat wires from the gas valve.
4. Use a slotted socket to unscrew the thermostat from the frypot.

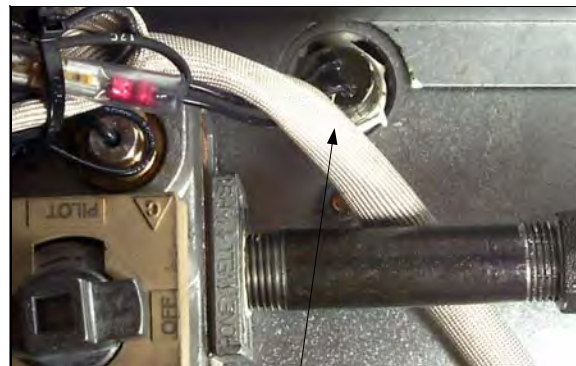

On G-Model fryers, the high-limit thermostat is accessed through the cabinet door.

5. Apply a small amount of Loctite™ PST56765 compound to the threads of the new thermostat.
6. Screw the replacement thermostat into the frypot, torquing to 180 inch-pounds.

1.8.5 Replacing Burner Ceramic Targets



DANGER

Drain the frypot or remove the handle from the drain valve before proceeding further.

1. Disconnect the fryer from the electrical power and gas supplies.
2. On FM35 fryers, remove sections of the square-drain as necessary to expose the burner.
3. Disconnect the wires from the gas valve terminal block and pilot coil, marking each wire to facilitate reconnection.
4. Disconnect the pipe union collar at the right side of the gas valve.
5. Remove the burner hanger screws and lower the front of the main burner. Pull it forward to clear the rear burner hanger, then lower the burner to the floor.
6. Raise the front of the fryer enough to slide the burner from under the fryer cabinet.
7. To replace a ceramic target only, remove the wire, straighten the target locking tab with a pair of needle nose pliers or a screwdriver, and slide the target up and off the bracket. Slide the replacement target onto the bracket and bend the locking tabs down.



Step 2: On FM35 fryers, sections of the drain system must be removed to access the burner assembly.



Step 3: Mark and disconnect the wires from the gas valve.



Step 5: These screws on each side of the drain valve must be removed to lower the burner from the frypot.

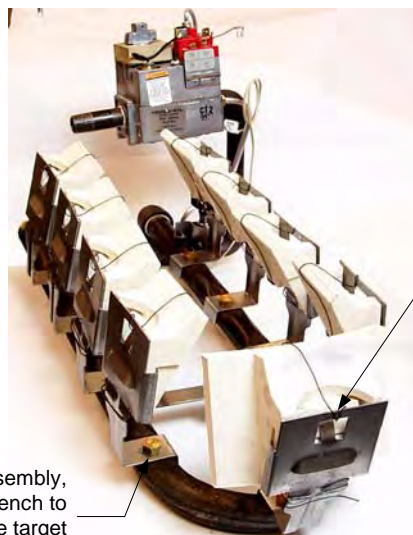

To replace the entire target assembly, use a 1/2-inch box end wrench to remove the orifice that holds the target to the manifold assembly.

To replace a ceramic target only, remove the wire, bend this tab outward, and slide the target up and off the bracket.

8. To replace the entire target assembly, use a ½-inch box end wrench to remove the brass orifice that holds the assembly to the burner manifold. Position the new assembly and reinstall the orifices.

 **WARNING**

Use extreme care to prevent cross-threading and stripping when reinstalling the brass orifices.

9. Reverse steps 1-8 to reinstall the burner assembly. Check spacing and alignment of targets in accordance with Section 1.5.

1.8.6 Replacing the Gas Valve

 **DANGER**

Drain the frypot or remove the handle from the drain valve before proceeding further.

1. Disconnect fryer from electrical and gas supplies
2. Disconnect the wires from the gas valve, marking each wire to facilitate reconnection.
3. Disconnect the pilot gas line fitting from the gas valve.
4. Disconnect the pipe union collars to the left and right of the gas valve and remove the valve.
5. Remove the pipefittings from the old gas valve and install on the replacement valve, using Loctite™ PST56765 or equivalent pipe thread sealant on threads.
6. Reverse steps 1-4 to install the replacement gas valve.

1.8.7 Replacing the Pilot Assembly or Thermopile

 **DANGER**

Drain the frypot or remove the handle from the drain valve before proceeding further.

1. Remove the burner assembly in accordance with steps 1-8 of Section 1.8.5.
2. To replace only the thermopile in fryers with the earlier design pilot assembly (see illustration at top of Page 1-9):
 - a. Disconnect the thermopile lead(s) from the gas valve pilot coil.
 - b. Remove the screws that secure the pilot assembly guard.
 - c. Bend the tab away from the base of the thermopile.
 - d. Press down on the top of the thermopile to force it out of the pilot assembly.
 - e. Reverse steps a through c to install the replacement thermopile.

c: Press down on top of thermopile, forcing it out of the pilot bracket.

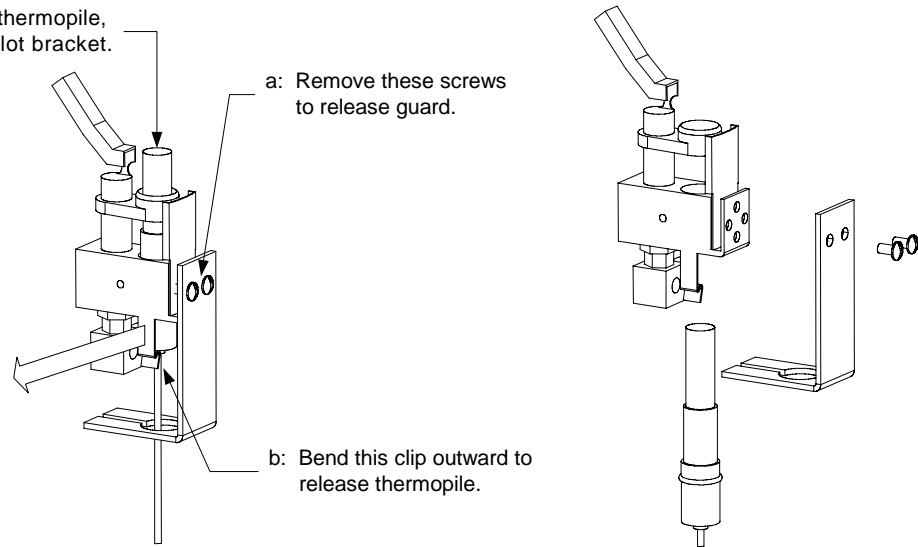

3. To replace only the thermopile in fryers with the current design pilot assembly (see illustration below), use a $\frac{7}{16}$ -inch open-end wrench to loosen the thermopile, then unscrew it from the pilot assembly. Screw the replacement into the pilot assembly and use a wrench to tighten it $\frac{1}{4}$ -turn past finger tight.

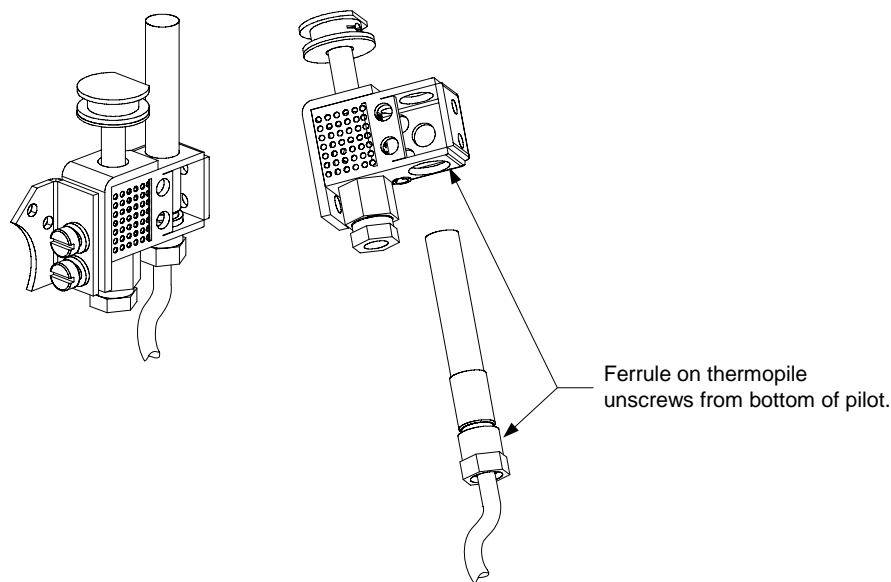

3. To replace the complete pilot assembly of either design:
 - a. Disconnect the pilot tubing from the bottom of the pilot assembly.
 - b. Disconnect the thermopile lead(s) from the gas valve pilot coil.
 - c. Remove the screw(s) from the pilot-mounting bracket to release the pilot assembly.
 - d. Reverse steps a through c to install the replacement pilot assembly.
4. Reinstall the burner assembly by reversing steps 1-8 of Section 1.8.5.

1.8.8 Replacing the Frypot

1. Drain the frypot.
2. Remove all accessories (e.g., frypot covers, basket lift arms, etc.) from the fryer.
3. Disconnect the fryer from the gas and electrical power supplies.

4. Remove the screws from the top cap above the control panel and lift it up and off the fryer(s).



Four screws, these two and two on each end, secure the topcap to the fryer.

5. If fryer is a G-Model, remove the thermostat knob.
6. Remove the control panel.
7. Loosen the setscrew on the flexible shaft and separate it from the thermostat shaft.
8. Remove the two screws holding the flexible shaft bracket and remove the flexible shaft and bracket.
9. Remove the control panel frame.

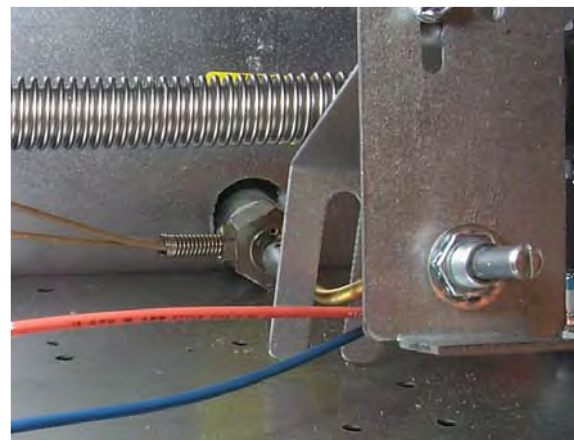

The flexible shaft on G-Model fryers must be disconnected from the thermostat and the shaft and bracket must be removed.

10. Remove the screw from the frypot hold-down bracket.



When the topcap is removed, this screw is exposed. It must be removed to free the frypot.

11. For fryers with a filter system, remove the square drain tubing from the drain valve.

12. Remove the screws from the sides and back of the fluecap and remove the fluecap.



Three screws, on each side of the fluecap, must be removed.

13. Disconnect the oil return lines or hoses on fryers equipped with filter systems.
14. Lift the frypot, complete with the burner, gas valve, flue, and drain valve, from the fryer cabinet. After lifting the frypot partially out of the cabinet, tilt the front downward to allow the drain valve to clear the cabinet top and front crossbar.
15. Remove the drain valve, hi-limit thermostat, and operating thermostat from the frypot and transfer them to the replacement frypot. Before installing the thermostats and drain valve on the replacement frypot, clean threads and apply Loctite™ PST56765 thread sealant or equivalent to the threads.
16. Reverse the steps of the procedure to install the new frypot.

⚠ CAUTION

Before installing the operating thermostat, high-limit thermostat, and drain valve on the replacement frypot, clean their threads and apply Loctite™ PST56765 thread sealant or equivalent to the threads.

1.9 Troubleshooting and Problem Isolation

This section is intended to provide technicians with a general knowledge of the broad problem categories associated with this equipment, and the probable causes of each. With this knowledge, the technician should be able to isolate and correct any problem encountered.

Problems you are likely to encounter can be grouped into these broad categories:

1. Pilot failures
2. Improper burner functioning
3. Improper temperature control
4. Filtration problems
5. Leakage problems

The main indicator of a gas or electrical circuit problem is that an entire battery of fryers fails to light. Verify that the quick disconnect fitting on the flexible gas hose is properly connected, the fryer is plugged in, and the main gas supply valve is open.

1.9.3 Problems Related to the Electrical Circuits

If gas is being supplied to the fryer, the next most likely cause of ignition failure is a problem in the millivolt circuit of the pilot system. If the fryer is equipped with a Filter Magic II filtration system, first verify that the drain valve is fully closed. (The valve handle interacts with a microswitch that must be closed for power to reach the gas valve. Often, although the valve handle appears to be in the closed position, the microswitch is still open.) If the valve is fully closed, or the fryer does not have a filtration system, refer to the troubleshooting guides.

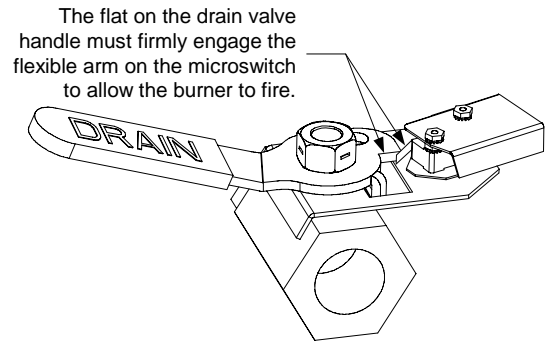

The drain valve handle interacts with a microswitch that prevents the burner from firing if the drain valve is open.

1.9.4 Problems Related to the Gas Valve

If the problem is not in the millivolt circuit of the pilot system, it is most likely in the gas valve itself. Follow these steps to check a Honeywell valve:

1. **Complete System Check:** With the thermostat contacts closed and gas cock dial “ON,” main burner should ignite. If not measure across terminals 2 and 3 as indicated by the diagram. If the reading is more than 180MV, replace the gas valve.
2. **System Resistance Check:** With the thermostat contacts closed and main burner “ON”, measure the millivolts between terminals 1 and 3 as indicated by the diagram. Reading should not be greater than 220MV, If greater, re-check thermostat leads and connections. Replace with new or heavier gauge wires if necessary. If the reading is still greater than 220MV, replace the thermostat.

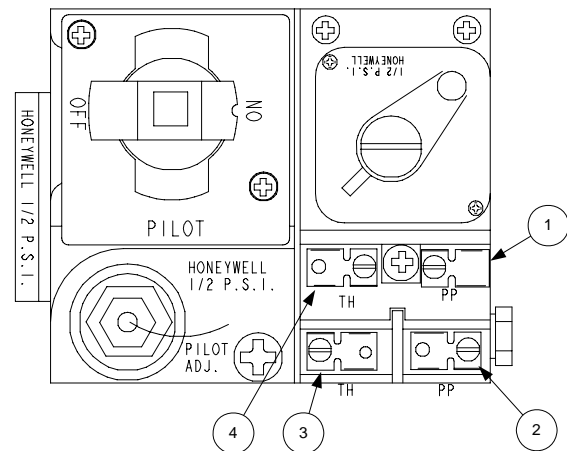

Test	Meter Setting	Meter Leads on Terminals		Acceptable Results
1	MV	2	3	Less than 180MV
2	MV	1	3	Less than 220MV
3	MV	1	2	110-36 MV

3. **Automatic Pilot Dropout Check:** With the thermostat contacts open, depress gas cock knob with pilot lit until maximum millivolt output is observed between terminals 1 and 2. Extinguish the pilot and observe the meter. The sound of the pilot magnet dropping should be audible. The dropout should occur between 110 MV and 36MV. If the dropout occurs outside those limits, replace the gas valve.

Follow these steps to troubleshoot a Robertshaw Valve:

1. **Complete System check:** With the thermostat contacts closed and gas cock dial “ON”, main burner should ignite. If not, measure across TP and TH terminals. If the reading is more than 100 MV, replace the gas valve.
2. **System Resistance Check:** With the thermostat contacts closed and main burner “ON”, measure the millivolt reading between THTP and TH terminals. Reading should be less than 80MV. If not, recheck thermostat leads and connections. Replace with new or heavier gauge wires if necessary. If the reading is still greater than 80 MV, replace the thermostat.

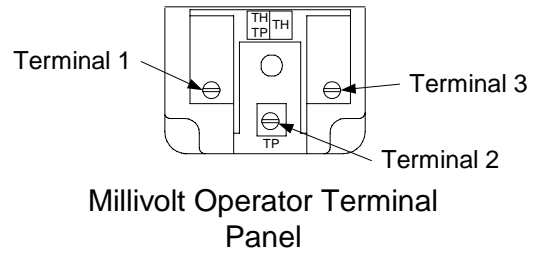

Test	Meter Setting	Meter Leads on Terminals		Acceptable Results
1	MV	TP	TH	Less than 100MV
2	MV	THTP	TH	Less than 80MV
3	MV	THTP	TP	120-30MV

3. **Automatic Pilot Dropout Check:** With the thermostat contacts open, depress gas cock knob with pilot lit until maximum millivolt output is observed between terminals THTP and TP. Extinguish the pilot and observe the meter. The sound of the pilot magnet dropping should be audible. The dropout should occur between 120MV and 30MV. If outside these limits, change the gas valve.

1.9.5 Improper Burner Functioning

The *burner lighting on one side only* may be caused by a missing or misaligned rear deflector target or improper burner manifold pressure. Clogged burner orifices are usually the cause of *gaps in burner firing*.

Fluctuating flame intensity is normally caused by either improper or fluctuating incoming gas pressure, but may also be the result of variations in the kitchen atmosphere. Verify incoming gas pressure in the same way as for “popping,” discussed in the preceding paragraphs. Variations in the kitchen atmosphere are usually caused by air conditioning and/or ventilation units starting and stopping during the day. As they start and stop, the pressure in the kitchen may change from positive or neutral to negative, or vice versa. They may also cause changes in airflow patterns that may affect flame intensity.

Flames “rolling” out of the fryer are usually an indication of negative pressure in the kitchen. Air is being sucked out of the fryer enclosure and the flames are literally following the air. If negative pressure is not the cause, check for high burner manifold gas pressure in accordance with the procedures in Chapter 5 of the Installation and Operation Manual (P/N 819-5776). An obstructed flue, which prevents the fryer from properly exhausting, may also be the cause.

An *excessively noisy burner*, especially with *flames visible above the flue opening*, may indicate that the burner gas pressure is too high, or it may simply be that the gas valve vent tube is blocked. If the gas pressure is correct and the vent tube is unobstructed, the gas valve regulator is probably defective.

Occasionally a burner may apparently be operating correctly, but nevertheless the fryer has a *slow recovery rate* (the length of time required for the fryer to increase the oil temperature from 250°F to 300°F (121°C to 149°C). The primary causes of this are low burner manifold pressure and/or misaligned or missing deflector targets. If both of these causes are ruled out, the probable cause is a gas valve regulator that is out of adjustment. Refer to the **Check Burner Manifold Pressure** procedure in the semi-annual checks and services section of Chapter 5 of the Installation and Operation Manual (P/N 819-5776).

1.9.6 Improper Temperature Control

Temperature control is a function of several interrelated components, each of which must operate correctly. The principle component is the operating thermostat. Other components that may affect temperature control are the high-limit thermostat and the gas valve. The high-limit thermostat is checked by comparing the resistance in its leads for a given temperature with the chart on Page 1-19. See Section 1.9.4 for the procedures for checking the gas valve.

Failure to Control at Setpoint

The problem will be with the thermostat itself. Possible causes are that the thermostat is out of calibration, the knob or flexible shaft is loose on the thermostat shaft, a thermostat wire is disconnected or broken, or the thermostat is defective. Refer to Section 1.7 for instructions on calibrating the thermostat. **To check for thermostat failure:** Determine the temperature of the oil in the frypot using a thermometer or pyrometer placed at the tip of the probe, then check the for a resistance through the leads that is approximately equal to that given in the Probe Resistance Chart on Page 1-19 for the corresponding temperature. If this checks OK, check for at least 5 megaohms of resistance through each of the leads to ground. If both checks are not OK, replace the thermostat.

1.9.7 Filtration Problems

The majority of filtration problems arise from operator error. A common error is placing the filter paper on the bottom of the filter pan rather than over the filter screen.

When the complaint is “the pump is running, but no oil is being filtered,” check the installation of the filter paper, including size. While you are checking the filter paper, verify that the O-rings on the bottom of the filter pan and on the male disconnect (at inside rear of filter cabinet) are present and in good condition. Missing or worn O-rings will allow the pump to suck air and decrease its efficiency.

If the pump motor overheats, its thermal overload will trip and the motor will not start until it is reset. If the pump motor does not start, press the red reset switch located on the end of the motor nearest the operator. If the pump then starts, something caused the motor to overheat. It may be just that several frypots were being filtered one after the other and the pump got hot. Letting the pump cool down for at least a half-hour is all that is required in this case. More often, the pump overheated for one of the following reasons:

- Shortening was solidified in the pan or filter lines.
- The operator attempted to filter oil or shortening that was not heated. Cold oil and shortening are thicker and can cause the pump motor to overheat.

If the motor tries to run but the pump does not, there is a blockage in the pump. Incorrectly sized or installed paper will allow food particles and sediment to pass through the filter pan and into the pump. When sediment enters the pump, the gears can bind up causing the motor to overload, again.

A pump seized by debris or hard shortening can usually be freed by manually moving the gears with a screwdriver or other instrument.

1. Disconnect power to the filter system.
2. Remove the input plumbing from the pump.
3. Use a screwdriver to manually turn the gears.
 - Turning the pump gears backwards will release a hard particle and allow it to be removed.
 - Turning the pump gears forward will push softer objects and solid shortening through the pump and allow free movement of the gears.

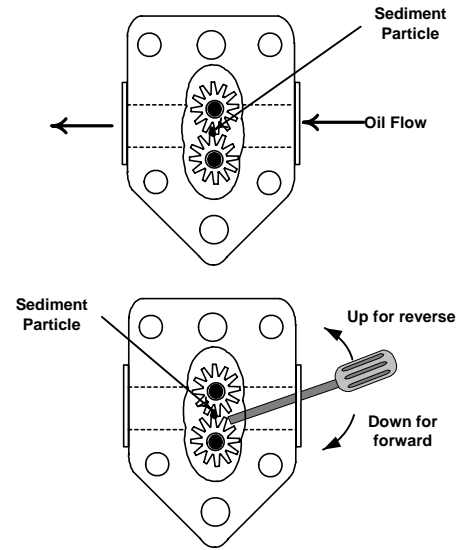

Incorrectly sized or installed paper will also allow food particles and sediment to pass through and clog the suction tube on the bottom of the filter carriage. Particles large enough to block the suction tube may indicate that the crumb tray is not being used.

Pan blockage can also occur if shortening is left in the pan and allowed to solidify. The heater strip on the suction tube is designed to prevent solidification of residual shortening left in the tube. It will not melt or prevent solidification of shortening in the pan. Blockage removal can be accomplished by forcing the item out with an auger or drain snake. Compressed air or other pressurized gases should not be used to force out the blockage. Possible problems with the Power Shower include clogged openings, shortening solidified in the tubes, missing clean-out plugs, and missing or worn O-rings. Cleaning the unit and replacing missing plugs and missing or worn O-rings will correct these problems.

The electronics of the Filter Magic II are simple and straightforward. Microswitches, attached to the drain valve handles of each vat and wired in parallel, provide the 24 VAC needed to activate the pump relay coil when the handles are moved to the ON position. The activated coil pulls in the pump motor switch, supplying power to the motor.

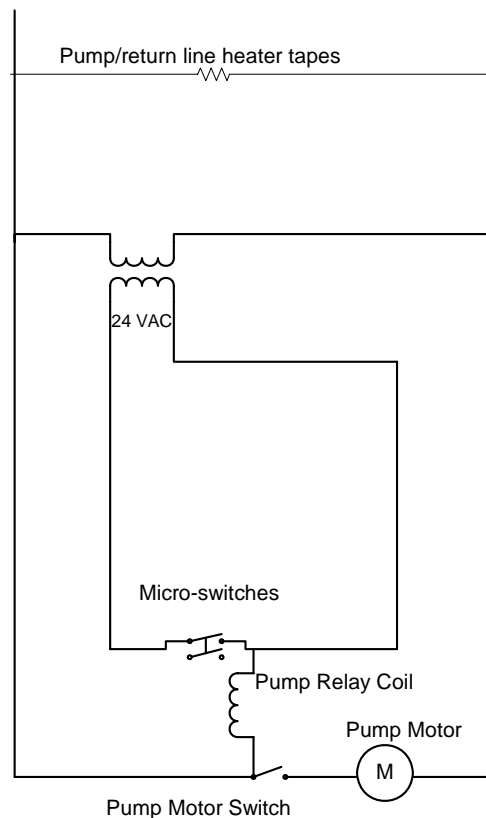

Filter Magic Simplified Wiring Diagram

The suction tube heater and flexible hose heater are wired directly into the 24 VAC source. They remain energized as long as the unit is plugged in.

1.9.8 Leakage

Leakage of the frypot almost always will be due to improperly sealed high-limit switches, thermostats/temperature probes, and drain fittings. When installed or replaced, each of these components must be sealed with Loctite™ PST56765 sealant or equivalent to prevent leakage. In very rare cases, a leak may develop along one of the welded edges of the frypot. When this occurs, the frypot must be replaced.

If the sides and/or ends of the frypot are coated with oil, the most likely cause is spillage over the top of the frypot rather than leakage.

The clamps, which hold the drain tube sections together, may loosen over time as the tubes expand and contract during use. If the section of drain tube connected to the drain valve is removed for whatever reason, make sure that its grommet is in good condition and properly fitted around the nipple of the drain when it is reinstalled. Also, ensure that the drain tube runs downward from the drain along its whole length and has no low points where oil or shortening may accumulate.

1.9.9 Basket Lift Malfunctions

35 Series fryers may optionally be equipped with automatic basket lifts to ensure uniform cooking times. The lifts may be configured for manual control or for control via a basket lift timer. Basket lifts will always come in pairs, although each operates independently.

In units configured for manual (push-button) controls, a mechanical or electrical timer controls voltage to the system. A rotary knob is turned to set the cook time, and pressing the button in the middle of the knob activates the motor.

In units with basket-lift timers, timing circuitry in the controller initiates and stops basket-lift operation based on variables set by the operator. When the product button is pressed, the timing circuitry activates a coil in the basket lift relay to supply power to the motor.

The basket lift consists of a cam and bell crank connected to the basket lift arm by a flat metal link. The cam is attached to a drive motor. The motor rotates the cam, thus raising or lowering the lift arm linked to the bell crank. A roller-activated microswitch is used to limit travel. When the push-button in the manual timer is pushed, the motor circuit is completed and the motor runs, lowering the basket. When the roller in the microswitch makes or loses contact with the cam, the switch is reversed and power to the motor is cut. At the end of the specified cooking time, the timer/controller reverses its switch position so that the motor circuit is again complete. The motor runs, raising the basket until contact with the cam is again made or lost.

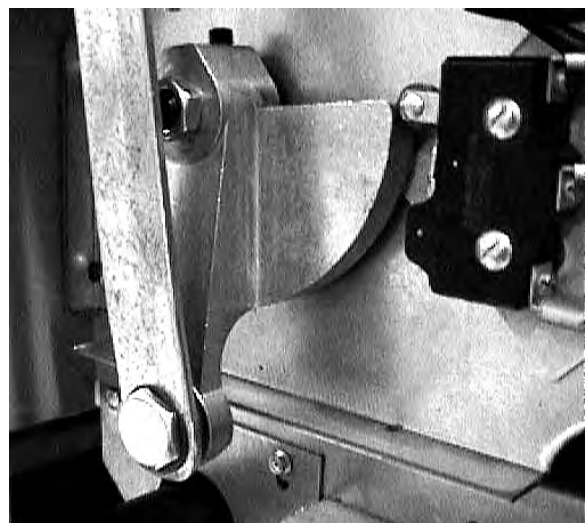

Left bell crank and cam with basket lift link shown in down position. Note microswitch in the upper right corner.

Problems with the basket lift system can be grouped into three categories:

- Binding/jamming problems
- Motor problems
- Electronics problems

Binding/Jamming Problems

Noisy, jerky or erratic movement of the lifts is usually due to lack of lubrication of the rods and their bushings. Apply a light coat of Lubriplate™ or similar lightweight white grease to the rod and bushings to correct the problem.

Motor Problems

If the lift cycles correctly but fails to remain in the up position (i.e., goes up, but then slowly settles back down into the frypot), the problem is a failed motor brake. A failed motor brake cannot be repaired and requires replacement of the motor itself.

If power is reaching the motor but the motor fails to run, the motor is burned out and must be replaced.

Electrical Problems

This category encompasses problems with the relays, microswitches, wiring, and controls. Troubleshooting the electronics of basket lifts is simply a process of verifying current flow through the individual components up to and including the motor. Using a multimeter set to the 250 VAC range, check the connections on both sides of the component for the presence of 120 VAC.

The wiring diagram on the following page identifies the components and wiring connection points.

Bell Crank Basket Lift Wiring Diagram

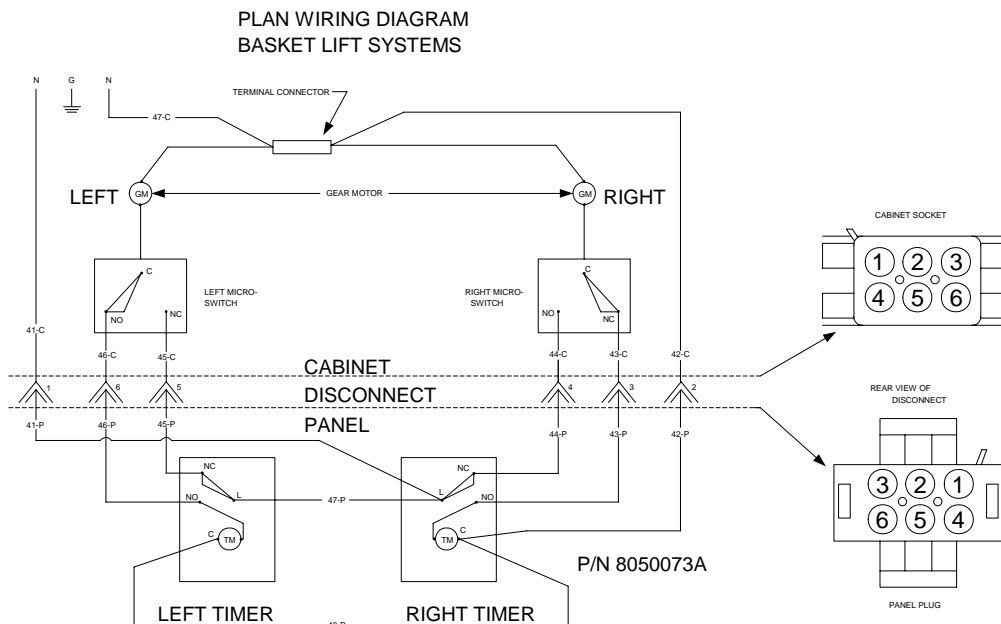

1.10 Probe Resistance Chart

<h3 style="text-align: center;">Probe Resistance Chart</h3> <p style="text-align: center;"><i>For use with H50 Series fryers manufactured with Minco Thermistor probes only.</i></p>																	
F	OHMS	C	F	OHMS	C	F	OHMS	C	F	OHMS	C	F	OHMS	C			
60	1059	16	130	1204	54	200	1350	93	270	1493	132	340	1634	171			
65	1070	18	135	1216	57	205	1361	96	275	1503	135	345	1644	174			
70	1080	21	140	1226	60	210	1371	99	280	1514	138	350	1654	177			
75	1091	24	145	1237	63	215	1381	102	285	1524	141	355	1664	179			
80	1101	27	150	1247	66	220	1391	104	290	1534	143	360	1674	182			
85	1112	29	155	1258	68	225	1402	107	295	1544	146	365	1684	185			
90	1122	32	160	1268	71	230	1412	110	300	1554	149	370	1694	188			
95	1133	35	165	1278	74	235	1422	113	305	1564	152	375	1704	191			
100	1143	38	170	1289	77	240	1432	116	310	1574	154	380	1714	193			
105	1154	41	175	1299	79	245	1442	118	315	1584	157	385	1724	196			
110	1164	43	180	1309	82	250	1453	121	320	1594	160	390	1734	199			
115	1174	46	185	1320	85	255	1463	124	325	1604	163	395	1744	202			
120	1185	49	190	1330	88	260	1473	127	330	1614	166	400	1754	204			
125	1195	52	195	1340	91	265	1483	129	335	1624	168	405	1764	207			

35 SERIES GAS FRYERS

CHAPTER 2: PARTS LIST

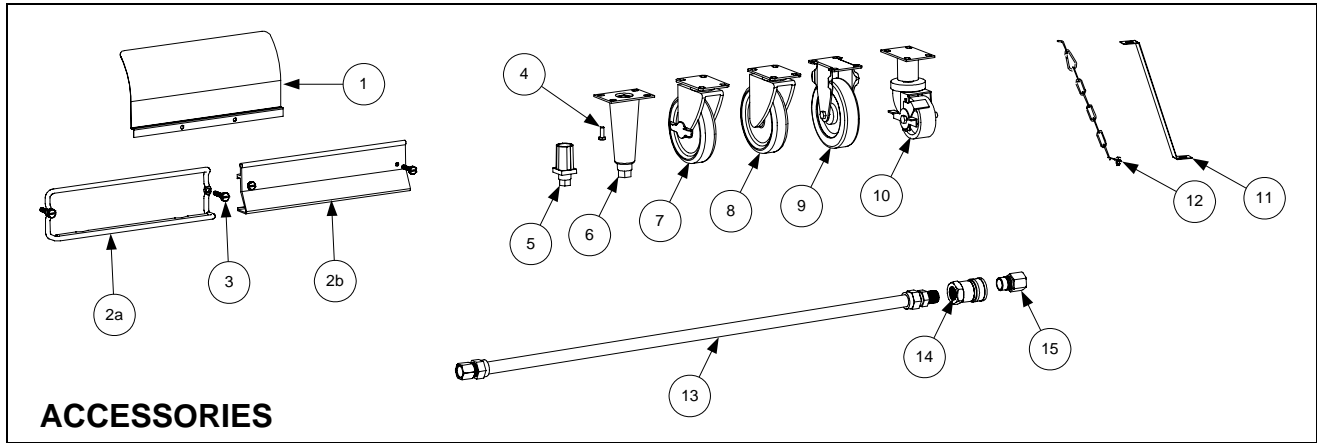

Item	Part #	Component
1	910-3557	Flue Heater Deflector
2a	810-1403	Basket Hanger, Wire Form
2b	810-1403	Basket Hanger, Extruded Aluminum (<i>no longer available – replaced by 810-1403</i>)
3	809-0171	Basket Hanger Screw
*	809-0921	Spacer, Aluminum (goes behind Item 2b and covers screw threads)
*	826-1351	Nut Retainer, 1/4-20 (Pkg. of 10) (receives Item 3)
4	826-1389	Screw, Leg Mounting (Pkg. of 10)
5	810-0007	Adjustable Leg, Filter Cabinet
6	806-3811	Legs (4 Per Set)
7	810-0357	Caster, 5" Swivel with Brake
8	810-0356	Caster, 5" Swivel without Brake
9	810-0378	Caster, 5" Rigid
10	810-0651	Caster, 3" with Brake, Filter Cabinet
11	826-1095	Anchor Strap Kit (for use on fryers equipped with legs only)
12	826-0900	Chain Restraint Kit (for use on fryers equipped with casters only)
13	810-0085	Flexible Gas Line 1-inch x 48-inch
	810-0084	Flexible Gas Line 3/4-inch x 48-inch
14	810-0073	Quick Disconnect Fitting, Female 1-inch
	810-0070	Quick Disconnect Fitting, Female 3/4-inch
15	810-0074	Quick Disconnect Fitting, Male 1-inch
	810-0072	Quick Disconnect Fitting, Male 3/4-inch
*	803-0271	Twin Basket
*	803-0032	Basket Support Rack, Wire (11.5-inch X 14.5-inch)
*	803-0037	Basket Support Rack, Screen (11.5-inch X 14.5-inch)
*	803-0188	Sediment Tray
*	803-0197	Frypot Clean-out Rod
*	910-7443	Top Connecting Strip, Frypot

* Not illustrated.

BASKET LIFT

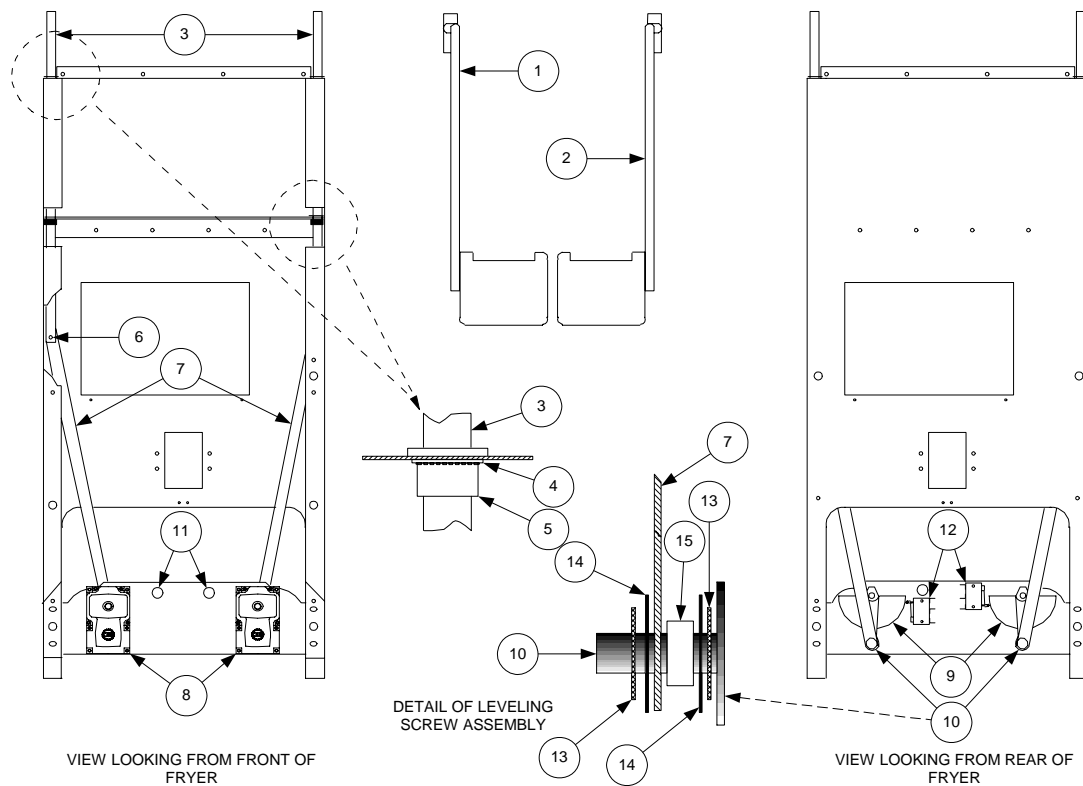

Item	Part #	Component
1	823-0040	Basket Lift Arm, MJ35 Left (<i>use 823-06931 for FM35 units</i>)
2	823-0039	Basket Lift Arm, MJ35 Right (<i>use 823-06932 for FM35 units</i>)
3	810-0192	Rod, Basket Lift
4	809-0082	Ring, Truarc Retaining
5	813-0035	Bushing, Bronze
6	810-0170	Pin, Connecting
7	920-6076	Link, Basket Lift
8		Gear Motor, Basket Lift
	807-0107	120VAC
	807-0108	240VAC
9	810-0052	Bell Crank
*	809-0480	Setscrew, 1/4-28 X 5/8-inch (secures Item 9 to Item 8)
10	809-0155	Leveling Screw
11	807-0124	Bushing, Plastic
12	807-0240	Microswitch
13	809-0194	Washer, 5/16-inch Steel
14	826-1381	Washer, Nylon (Pkg. of 10)
15	810-0220	Spacer, Tubular
*	900-3783	Panel, Cold Rolled Steel Access (<i>use 910-3783 for stainless steel</i>)
*	806-2079SP	Wiring Harness, Basket Lift Motor
*	806-7019SP	Wiring Harness, Non-Modular Basket Lift
*	809-0503	Screw, 8-32 x 1 1/2-inch Gear Motor Mounting (Hex Head)

* Not illustrated.

CABINETRY

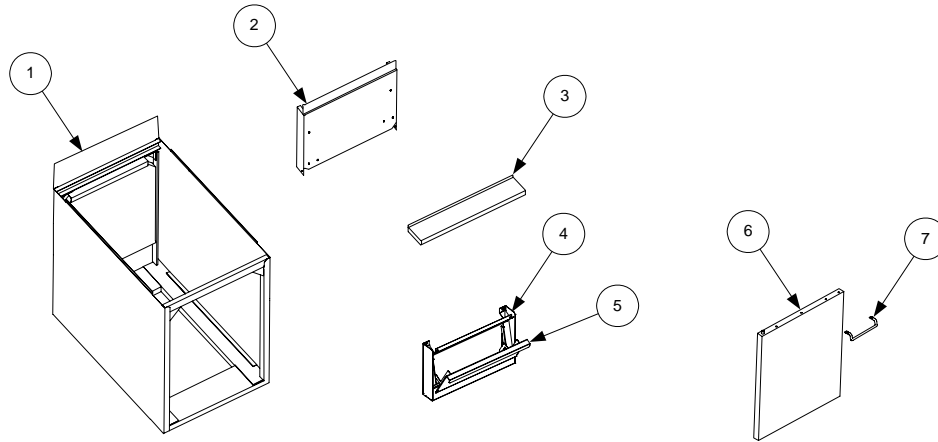

Item	Part #	Component
1		Cabinet Assembly
	806-45981SP	Stainless Steel
	806-4598SP	Cold Rolled Steel
2		Flue Cap
	910-5040	Single
	910-5041	Double
	910-5042	Triple
3		Top Cap
	824-0442SP	Single
	824-0443SP	Double
	824-0444SP	Triple
4		Control Panel Assembly with Thermostat Access Door
	806-5287	Single
	806-4733	Double
	806-4734	Triple
5	910-4480	Thermostat Access Door
6		Door Assembly
	806-8320	Short, Cold Rolled Steel (used on G-Series units only)
	806-6405SP	Short, Stainless Steel (used on G-Series units only)
	806-3338	Long, Cold Rolled Steel (used on all except G-Series units)
	806-3337	Long, Stainless Steel (used on all except G-Series units)
7	810-1422	Handle, Door (wire form)
*	810-0275	Door Hinge Pin Spring Lock
*	106-0554SP	Door Pin Assembly
*	810-1508	Hinge, Door
*	810-0066	Magnet, Door
*	910-6039	Trough, Backsplash
*	806-5518	Cover, Frypot

* Not illustrated.

DRAIN SYSTEM COMPONENTS

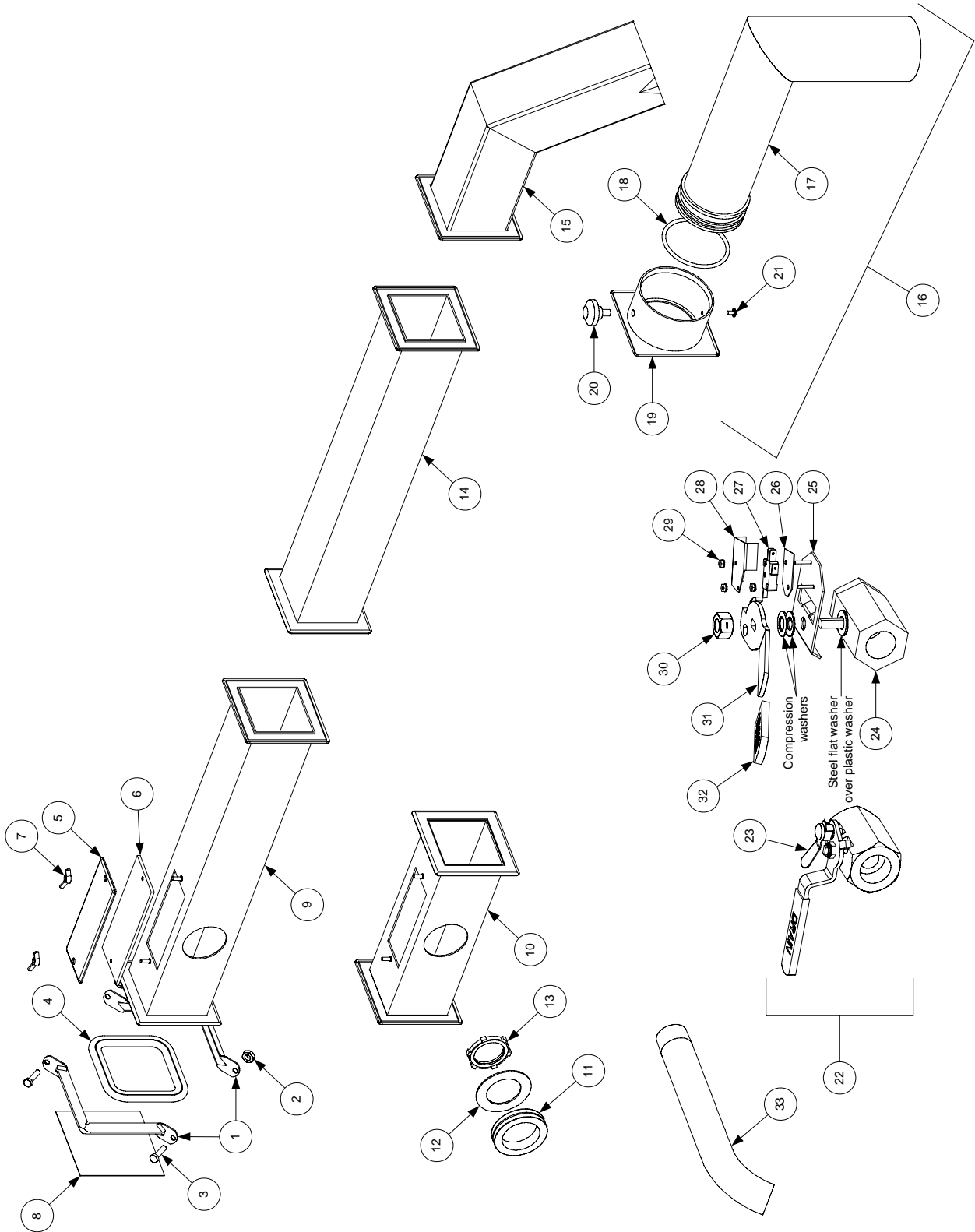

Item	Part #	Component
*	826-0877	Kit, Clamp Service (Contains 2 each of Items 1-3 and 1 of Item 4)
1	810-0396	Clamp Section (Requires 2 per connection)
2	809-0071	Nut, ¼–20
3	826-1375	Screw, 10–32 X ¾
4	816-0032	Seal (Connection Gasket)
5	826-1348	Cover, Clean-out (Pkg. of 5)
6	816-0021	Gasket, Clean-out
7	826-1382	Wing Nut, Clean-out Cover Retaining (Pkg. of 10)
8	900-0757	Cover, Drain End
9	823-0717	Full Vat, 15.5-inches Long
10	823-0718	End, Full Vat, 8.12-inches Long
*	813-0284	Nipple, 1-inch x ¾-inch (connects drain valve to drain tube)
11	816-0092	Grommet, Drain Tube
12	826-1345	Washer, Drain Tube Retaining (Pkg of 25) (1⅜-in. ID x 2 ³ / ₁₆ -in. OD)
13	809-0347	Nut, Drain Tube Retaining
14	823-0731	Extension, Spreader Cabinet, 15.5-inches Long
15	823-0719	Drain Outlet, Fixed
16	806-4068	Drain Outlet Assembly, Swivel
17	823-1091	Drain Tube, Swivel
18	816-0083	O-Ring, 2.5-inches ID
19	823-1092	Collar, Drain
20	810-0388	Knob, Clamping
21	809-0115	Screw, 10–32
22	810-1569	Valve w/Handle, 1.25-inch Drain (for use on MJ35 units)
23	810-1568	Handle w/Lock, Drain Valve
24	810-1020	Valve, 1.25-inch Drain (for use on FM35 units)
25	806-8137	Bracket, Drain Safety Switch
26	816-0220	Insulation, Drain Safety Switch
27	807-2103	Switch, Drain Safety
28	900-2841	Cover, Drain Safety Switch
29	809-0237	Nut, 4-40 Keps Hex
30	809-0540	Nut, ½-inch 2-Way Lock
31	810-0820	Handle, Drain Valve w/o Lock
32	816-0211	Sleeve, Drain Valve Handle
33	812-1226SP	Extension, Drain

* Not illustrated.

FILTER BOXES

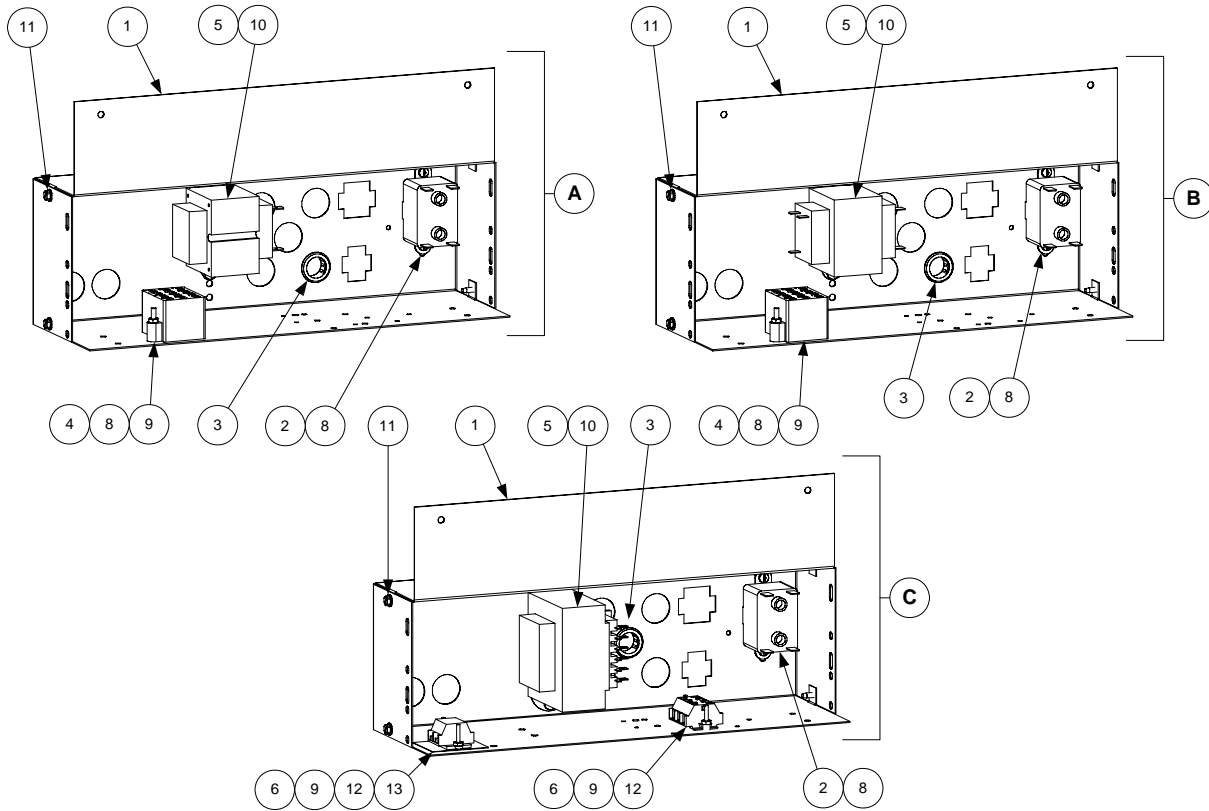

Item	Part #	Component
A	806-4359SP	Box Assembly, 120VAC Non-CE Filter
B	806-4360	Box Assembly, 208-240VAC Non-CE Filter
C	806-6709	Box Assembly, 230VAC CE Filter
1	200-0410	Box, Filter
2	807-0012	Relay, 18 Amp 1/3-HP 24V Coil
3	807-0124	Bushing, Heyco
4	807-0276	Block, Terminal
5		Transformer
	807-0800	120/24VAC, 50/60Hz, 50VA (<i>used with Item A</i>)
	807-0680	208-240/24VAC, 50/60Hz, 43VA (<i>used with Item B</i>)
	807-1999	208-230/24VAC, 50/60Hz, 50VA (<i>used with Item C</i>)
6	826-1366	Nut, 4-40 Hex Keps (Pkg. of 25)
7	826-1358	Nut, 6-32 Hex (Pkg. of 25)
8	809-0050	Nut, 8-32 Hex
9	826-1359	Screw, 4-40 X 3/4-inch Slotted Round Head (Pkg. of 25)
8	809-0096	Screw, 6-32 X 5/8-inch Slot Head
9	809-0097	Screw, 6-32 X 1-inch Slotted Truss Head
10	826-1363	Screw, 8-32 X 1/2-inch Slotted Truss Head (Pkg. of 25)
11	809-0360	Screw, 8-32 X 3/8-inch Slotted Washer Head
12	810-1164	Block, Terminal
13	816-0217	Insulation, Terminal Block
*	WIR0010SP	Wire Assembly, 120-240V Non-CE Filter Control Box
*	WIR0146SP	Wire Assembly, 230V CE Filter Control Box

* Not illustrated.

FILTER PANS

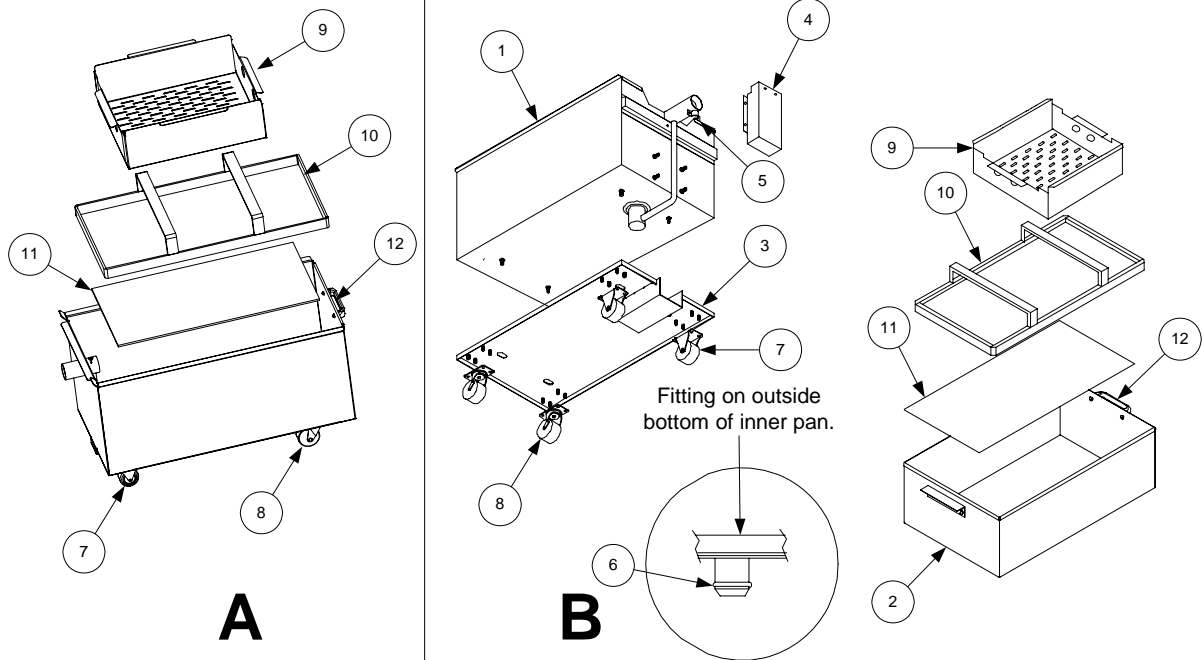

Item	Part #	Component
A	806-9255SP	One-Piece Filter Pan Assembly (Items 7, 8, 10, 11, and 12)
	823-2751SP	One-Piece Filter Pan
B	806-6093SP	Two-Piece Pan Assembly (Unique components are listed below.)
	806-4338SP	Outer Pan Assembly (Items 1, 3, 4, 5, 7, 8, and 806-4373)
1	823-1360SP	Outer Pan
	806-5282SP	Inner Pan Assembly (Items 2, 6, 10, 11, and 12)
2	823-1731SP	Inner Pan
3	823-1361	Base, Filter Pan Assembly
4	824-0291	Cover, Suction Tube
5	910-1350	Clamp, Suction Tube
6	816-0117	O-Ring, .609 OD
*	806-4373	Heater Strip Assembly
*	811-0861	Insulation, Foam
*	811-0746	Insulation, Aluminum (50-yard/46m roll)
Components Used on Both Designs		
7	810-0005	Caster, Rigid
8	810-0006	Caster, Swivel
9	824-0416	Crumb Screen
10	810-1406	Hold Down Ring Assembly
11	900-8827	Sanagrid Filter Screen
12	810-0180	Handle, Filter Pan
*	803-0170	Paper, Filter (100 sheets)
*	803-0002	Powder, Filter (100 1-cup applications)

* Not illustrated.

FRYPOTS

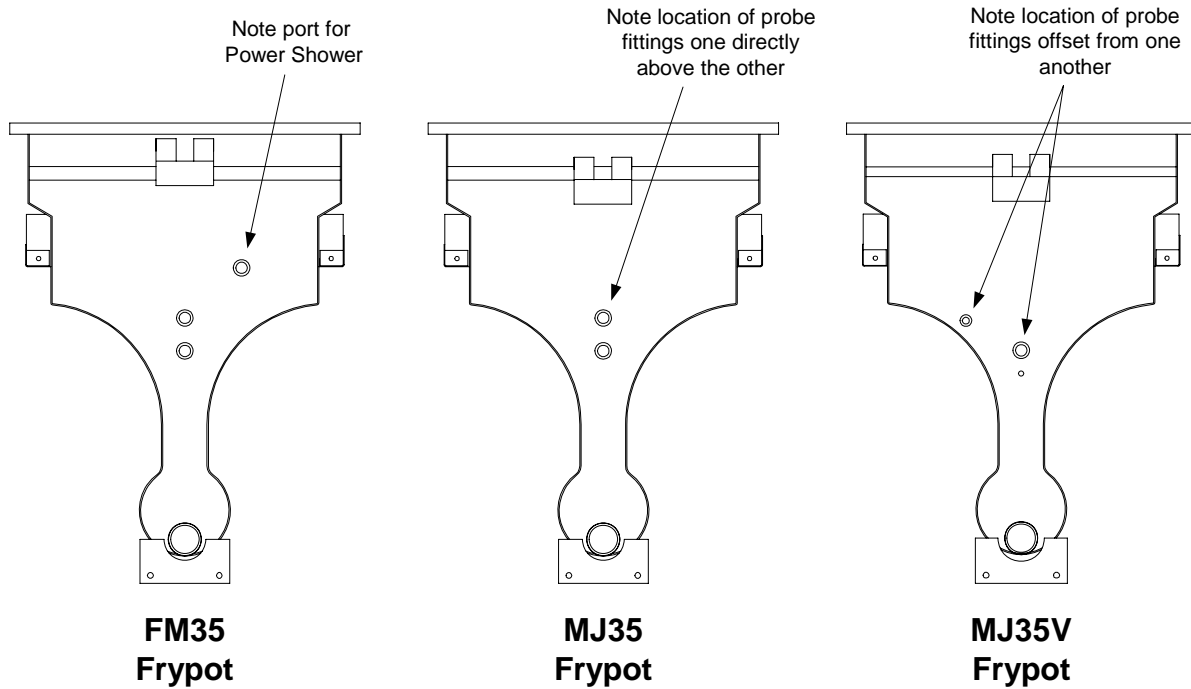

Item	Part #	Component
		Frypots without Insulation
	823-1111SP	Frypot without Insulation, Stainless Steel, FM35
	823-0981SP	Frypot without Insulation, Stainless Steel, MJ35
	823-2365SP	Frypot without Insulation, Stainless Steel, MJ35V
	823-1112	Frypot without Insulation, Cold Rolled Steel, FM35
	823-0980SP	Frypot without Insulation, Cold Rolled Steel, MJ35
	823-2364SP	Frypot without Insulation, Cold Rolled Steel, MJ35V
		Frypot with Flue and Insulation Installed
	806-4080SP	Frypot Assy, Stainless Steel, FM35
	806-4093SP	Frypot Assy, Stainless Steel, FM35 (used in Canadian units only)
	806-3942SP	Frypot Assy, Stainless Steel, MJ35
	806-7709SP	Frypot Assy, Stainless Steel, MJ35V
	806-4081SP	Frypot Assy, Cold Rolled Steel, FM35
	806-4092SP	Frypot Assy, Cold Rolled Steel, FM35 (used in Canadian units only)
	806-3943SP	Frypot Assy, Cold Rolled Steel, MJ35
	806-7708SP	Frypot Assy, Cold Rolled Steel, MJ35V
		Flue Assembly with Insulation
*	806-0094	MJ35 (used in Canadian units only)
*	806-0289SP	J2XLR (used in Canadian units only)
*	806-3490SP	MJ35 (has no Rear Deflector Box)
*	806-4082	FM35 (has Rear Deflector Box)
*	806-4094	FM35 (used in Canadian units only)

* Not Illustrated.

THIS PAGE INTENTIONALLY LEFT BLANK

GAS VALVES AND BURNER COMPONENTS

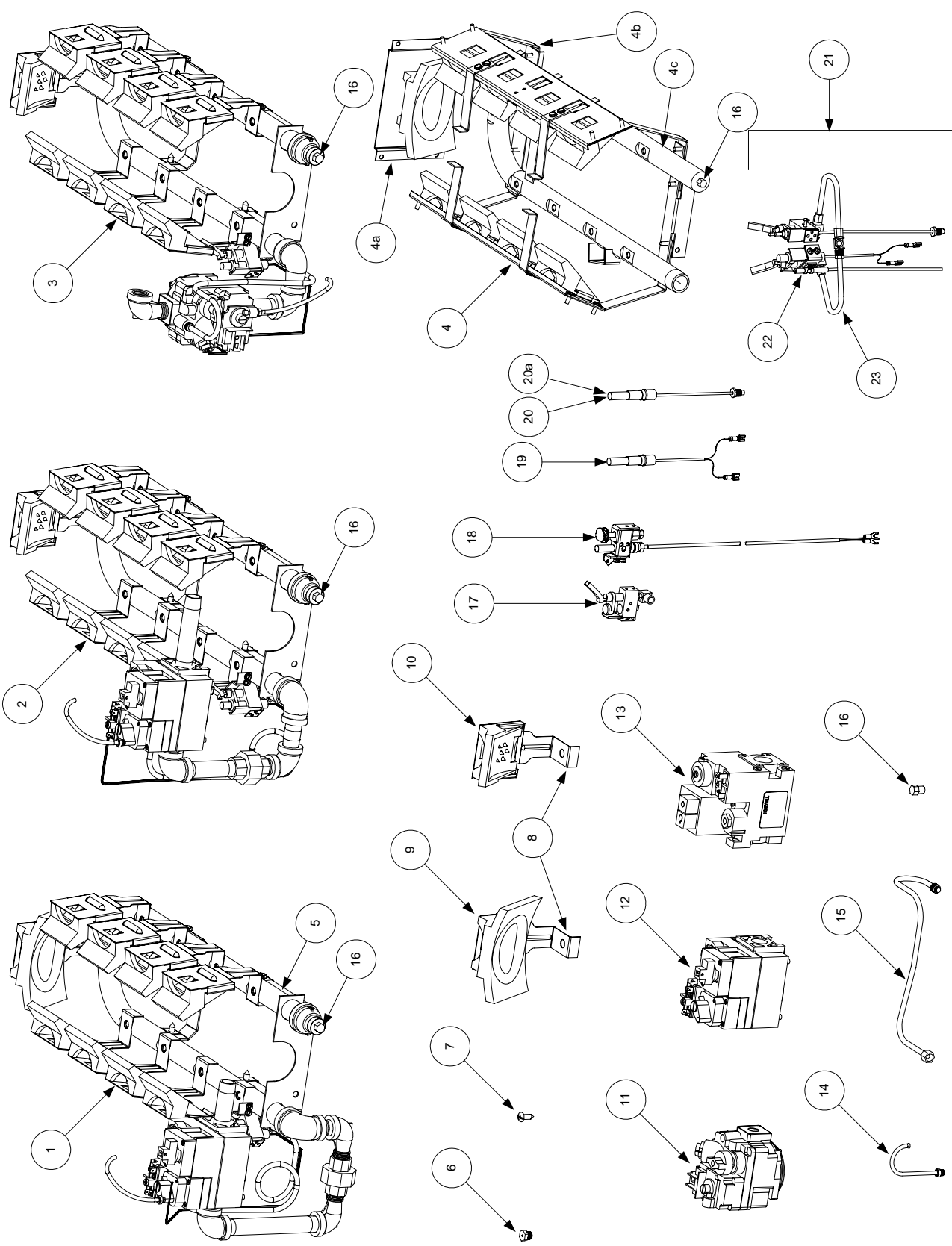

Item	Part #	Component
1		Burner Assembly, Non-CE MJ35, Complete with Gas Valve
	106-0132SP	Natural Gas (G20/G25)
	106-0235SP	Propane Gas (G31)
2		Burner Assembly, Non-CE FM35, Complete with Gas Valve
	106-0238SP	Natural Gas (G20/G25)
	106-0239SP	Propane Gas (G31)
3		Burner Assembly, Non-CE J2X, Complete with Gas Valve
	106-0237SP	Natural Gas (G20/G25)
	106-0236SP	Propane Gas (G31)
4	806-7222SP	Burner Assembly, CE MJ35, w/o Gas Valve or Piping
4a	910-2686	CE Rear Deflector (Target) Mounting Bracket
4b	806-7947	CE Deflector (Target) Assembly (Fits either side.)
4c	823-2319	Manifold, CE MJ35 Burner
5	826-1917	Manifold, Non-CE MJ/FM35 and J2X
6		Orifice
	810-0129	Natural Gas (G20/G25), 1.70mm
	810-0134	Propane Gas (G31), 1.05mm
7	809-0170	Screw, Deflector (Target) Mounting Bracket
8	910-1465	Bracket, Deflector (Target) Mounting
9	806-3605SP	Deflector (Target) Assembly, Large Rear (includes Item 8)
10	806-4720SP	Deflector (Target) Assembly, Side & Small Rear (includes Item 8)
11	Discontinued	Gas Valve, Robertshaw Millivolt (<i>Use conversion kit 826-1579 for Natural Gas (G20/G25) or 826-1580 for Propane Gas (G31)</i>)
12		Gas Valve, Honeywell Millivolt, for use on Non-CE units
	807-1603	Natural Gas (G20/G25)
	807-1604	Propane Gas (G31)
13		Gas Valve, Honeywell Millivolt, for use on CE units
	806-7101	Natural Gas (G20/G25)
	806-7102	Propane Gas (G31)
14	810-0691	Vent Tube, Gas Valve
15	810-0703	Gas Line, 0.25-inch x 17.50-inch (<i>for 15.00-inch line, use 810-2602</i>)
16	813-0154	Plug, Gas Pressure Test Port
17		Pilot Assembly (before 12/02) (<i>Does not include thermopile.</i>)
	810-0426	Natural Gas (G20/G25)
	810-0427	Propane Gas (G31)
18		Pilot Assembly (after 11/02) (<i>for thermopile only, use 807-3485</i>)
	106-1908SP	Natural Gas (G20/G25) (<i>for pilot only, use 810-2007</i>)
	106-1909SP	Propane Gas (G31) (<i>for pilot only, use 810-2022</i>)
19	810-1873	Thermopile, Split-Lead w/Push-on Terminals (<i>use 810-0159 for fork terminals</i>)
20	810-0617	Thermopile, Single Screw-in Lead
20a	810-0162	Thermopile, Screw-in with Small Barrel (<i>also requires adapter 810-0425</i>)
21		Pilot and Thermopile Assembly, CE Dual
	106-0259	Natural Gas (G20/G25) (<i>for thermocouple only, use 812-1284</i>)
	106-0260	Propane Gas (G31) (<i>for thermocouple only, use 812-1284</i>)
22	807-1906	Element, Piezo Igniter (<i>trigger is Part Number 810-1001</i>)
23	810-1173	Gas Line, 0.25-inch x 8.5-inch

NOTE: Item 18 includes Bracket 200-0956, Screws 809-0906, and Lock Washers 809-0184.

ITEM	PART #	COMPONENT
1		Pump Motor
	826-1712	100-120 VAC 50/60Hz (includes gasket 816-0093)
	826-1756	208 VAC 50/60 Hz (includes gasket 816-0093)
	826-1270	230-250 VAC 50/60 Hz (includes gasket 816-0093)
*	806-6728SP	Pump Motor Wiring Assembly (used with above motor kits)
2	826-1264	Pump, 4 GPM (15 LPM) (includes gasket 816-0093 and mounting screws)
3	813-0265	Nipple, ½-inch x 2 ½-inch
4	813-0062	Elbow, ½-inch x 90°
5	813-0368	Nipple, ½-inch x 16-inch
6	813-0156	Pipe Plug, ½-inch
7	813-0003	Tee, ½-inch
8	810-1057	Flexline, 13-inch Oil Return (has female ends)
*	810-1668	Adapter, Male (used with Item 8; two required)
9	813-0275	Nipple, ½-inch x 9-inch
10	810-0278	Valve, ½-inch Ball
11	902-0883	Handle, Valve
*	900-1853	Handle, Oil Return Valve (attaches to item # 11)
12	813-0165	Elbow, ½-inch x 90° Street
13	813-0022	Nipple, ½-inch Close
14	823-1356	Disconnect Fitting
15	826-1392	O-Ring (pkg of 5)
16	816-0102	Grommet, Oil Diverter
17	900-1472	Diverter, Oil
18	910-1627	Bracket, Male Disconnect Support
19	806-4694SP	Contact Block Assembly
*	813-0117	Nipple, ½-inch x 3½-inch
*	807-1600	Thermal Switch, 100-120V Baldor Motors
*	807-1601	Thermal Switch, 200-250V Baldor Motors
*	807-1598	Thermal Switch, 100-120V Magnatek Motors
*	807-1599	Thermal Switch, 200-250V Magnatek Motors
*	807-2016	Wiring Harness, Controller to Filter
*	807-1408	Heater Strip, 120 VAC 50W, 70-inch
*	807-2050	Heater Strip, 250 VAC 90W, 70-inch
*	811-0746	Tape, Aluminum (2-inch x 50-yard (46m) roll)

* Not illustrated

POWER SHOWER AND OIL RETURN HANDLE COMPONENTS

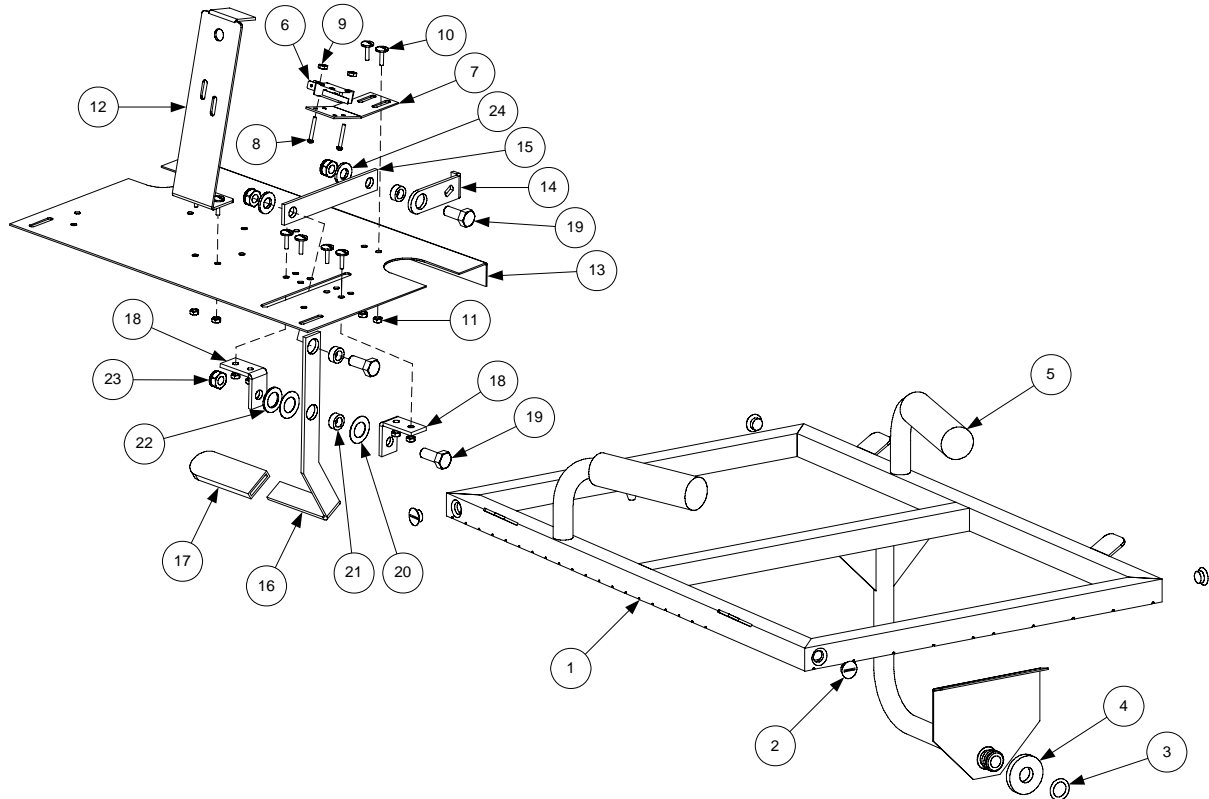

Item	Part #	Component
1	806-4542SP	Power Shower
2	809-0415	Screw, Power Shower Clean-out
3	826-1344	O-Ring, Power Shower (Pkg. of 5)
4	826-1390	Seal, Power Shower (Pkg. of 5)
5	814-0001	Grip, Power Shower Handle
6	807-2103	Microswitch, Oil Return
7	900-1078	Bracket, Oil Return Switch
8	826-1359	Screw, 4-40 X ¾-inch Slotted Round Head (Pkg. of 25)
9	826-1366	Nut, 4-40 Hex Keys (Pkg. of 25)
10	826-1363	Screw, 8-32 X ½-inch Slotted Truss Head (Pkg. of 25)
11	809-0050	Nut, 8-32 Hex
12	900-2129	Bracket, Thermostat Mounting
13	900-3837	Shield, FM35 Component
14	900-0239	Arm, Oil Return Valve
15	920-0220	Link, Oil Return Valve
16	900-1853	Handle, Oil Return
17	814-0047	Sleeve, Red Handle
18	810-1999	Bracket, Valve Handle
19	809-0142	Screw, 5/16 X ¾-inch Hex Cap
20	826-1381	Washer, Nylatron (Pkg. of 10) (2 required – one on each side of Item 21)
21	810-0220	Spacer, .493-inch Tubular
22	809-0200	Washer, ½-inch Flat
23	809-0056	Nut, 5/16-24 Nylon Lock
24	809-0194	Washer, 5/16-inch Flat

THERMOSTATS, TIMER, AND RELATED COMPONENTS

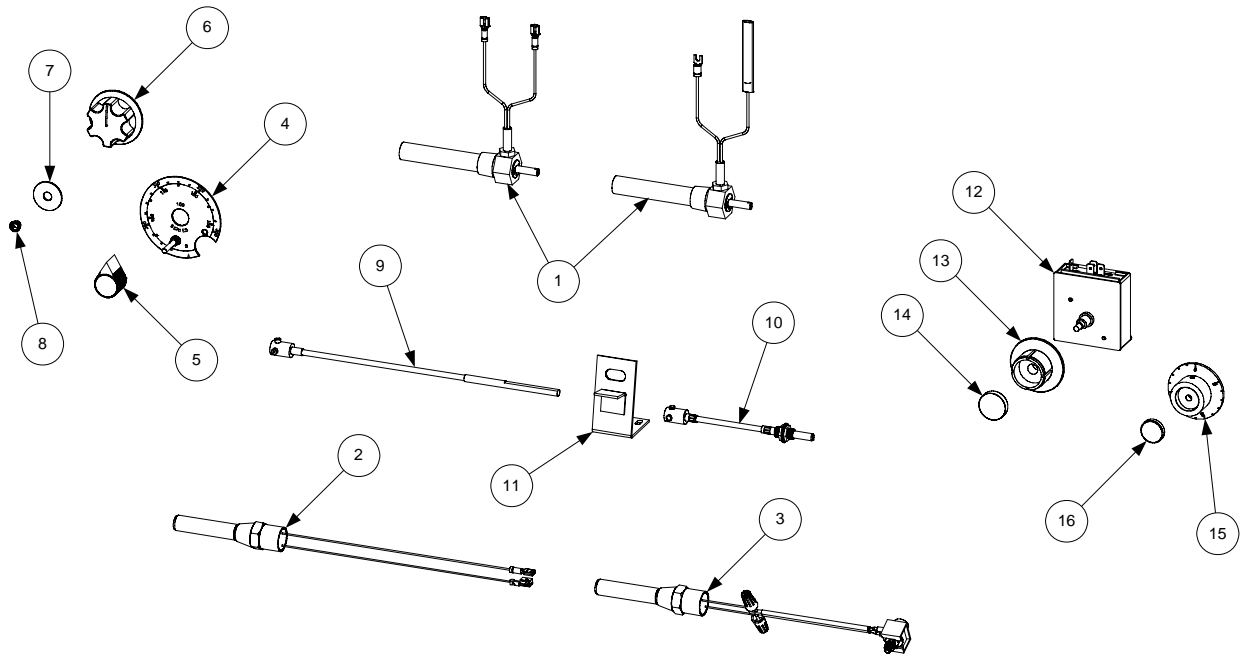

NOTE: Leads on Items 1, 2 and 3 are depicted shorter than they actually are.

Item	Part #	Component
1		Thermostat Assembly, Operating
	806-0184	w/Two Push-on Terminals, Non-CE
	806-7972	W/One Push-on and One Spade Terminal, CE
	806-5816	w/Inline Connector
2	826-1177	Thermostat, Non-CE 425°F High-Limit (has assortment of terminals)
3	806-7550	Thermostat, CE 218°C High-Limit (has screw-in gas valve adapter)
4	806-0087SP	Thermostat Dial Plate Assembly
*	802-1458	Replacement Label for Thermostat Dial
5	810-0110	Thermostat Knob for Fryers Without Control Panel (used with Item 4)
6	810-0334	Thermostat Knob for Fryers With Control Panel
7	900-0031	Plug Button
8	807-0123	Heyco Bushing
*	826-1367	Screw, Dial Plate (Pkg. of 25)
9	810-0345	Shaft, Thermostat Flexible Extension (7.25-inch)
10	810-1651	Shaft, Thermostat Flexible Extension (5.50-inch)
11	823-1330	Bracket, MJ35 Thermostat Mounting (<i>see Page 2-14 for FM35 bracket</i>)
12	807-3087	Timer, 15-Minute Electronic (includes Items 13 and 14)
*	826-1552	Timer Kit, 15-Minute Electronic (<i>use to replace discontinued mechanical timer</i>)
13	810-1822	Knob, Replacement 15-Minute Electronic Timer (used with Item 12)
14	810-1823	Push Button, Replacement White (used with Item 12)
15	810-1733	Knob, 15-Minute Mechanical Timer (used with discontinued mechanical timer)
16	814-0033	Push Button, Replacement Black (used with Item 15)

* Not Illustrated.

THIS PAGE INTENTIONALLY LEFT BLANK



Welbilt offers fully-integrated kitchen systems and our products are backed by KitchenCare[®] aftermarket parts and service. Welbilt's portfolio of award-winning brands includes Cleveland[™], Convotherm[®], Crem[®], Delfield[®], Frymaster[®], Garland[®], Kolpak[®], Lincoln[®], Merco[®], Merrychef[®] and Multiplex[®].

Bringing innovation to the table • welbilt.com