



# FE155 Rethernalizer

## Service and Parts

# **Frymaster**<sup>®</sup>



Frymaster, a member of the Commercial Food Equipment Service Association, recommends using CFESA Certified Technicians.

**24-Hour Service Hotline 1-800-551-8633**

PRINTED IN THE USA

[www.frymaster.com](http://www.frymaster.com)

Email: [service@frymaster.com](mailto:service@frymaster.com)



06/2023

**Please read all sections of this manual and retain for future reference.**

**NOTICE**

This appliance is intended for professional use only and is to be operated by qualified personnel only. A Frymaster Factory Authorized Servicer (FAS) or other qualified professional should perform installation, maintenance, and repairs. Installation, maintenance, or repairs by unqualified personnel may void the manufacturer's warranty.

**NOTICE**

Drawings and photos used in this manual are intended to illustrate operational, cleaning and technical procedures and may not conform to onsite management operational procedures.

**NOTICE**

IF, DURING THE WARRANTY PERIOD, THE CUSTOMER USES A PART FOR THIS FRYMASTER DEAN EQUIPMENT OTHER THAN AN UNMODIFIED NEW OR RECYCLED PART PURCHASED DIRECTLY FROM FRYMASTER DEAN, OR ANY OF ITS AUTHORIZED SERVICE CENTERS, AND/OR THE PART BEING USED IS MODIFIED FROM ITS ORIGINAL CONFIGURATION, THIS WARRANTY WILL BE VOID. FURTHER, FRYMASTER DEAN AND ITS AFFILIATES WILL NOT BE LIABLE FOR ANY CLAIMS, DAMAGES OR EXPENSES INCURRED BY THE CUSTOMER WHICH ARISE DIRECTLY OR INDIRECTLY, IN WHOLE OR IN PART, DUE TO THE INSTALLATION OF ANY MODIFIED PART AND/OR PART RECEIVED FROM AN UNAUTHORIZED SERVICE CENTER.

** DANGER**

Improper installation, adjustment, maintenance or service, and unauthorized alterations or modifications can cause property damage, injury, or death. Read the installation, operating and service instructions thoroughly before installing or servicing this equipment. Only qualified service personnel may convert this appliance to use a gas other than that for which it was originally configured.

** DANGER**

Adequate means must be provided to limit the movement of this appliance without depending upon the gas line connection. Single fryers equipped with legs must be stabilized by installing anchor straps. All fryers equipped with casters must be stabilized by installing restraining chains. If a flexible gas line is used, an additional restraining cable must be connected at all times when the fryer is in use.

** DANGER**

The front ledge of the unit is not a step. Do not stand on the rethermalizer. Serious injury can result from slips or contact with the hot water.

** DANGER**

Do not store or use gasoline or other flammable vapors and liquids in the vicinity of this or any other cooking appliance.

** WARNING**

No structural material on the fryer should be altered or removed to accommodate placement of the fryer under a hood. Questions? Call the Frymaster Service Hotline at 1-800-551-8633.

 **WARNING**

Do not bang fry baskets or other utensils on the fryer's joiner strip. The strip is present to seal the joint between the frypot. Banging fry baskets on the strip to dislodge shortening will distort the strip, adversely affecting its fit. It is designed for a tight fit and should only be removed for cleaning.

**IMPORTANT**

Safe and satisfactory operation of Frymaster equipment depends upon its proper installation. Installation **MUST** conform with local codes, or in the absence of local codes, to European Community (CE) Standards.

**COMPUTERS**  
**FCC**

This device complies with Part 15 of the FCC rules. Operation is subject to the following two conditions: 1) This device may not cause harmful interference, and 2) This device must accept any interference received, including interference that may cause undesired operation. While this device is a verified Class A device, it has been shown to meet the Class B limits.

**CANADA**

This digital apparatus does not exceed the Class A or B limits for radio noise emissions as set out by the ICES-003 standard of the Canadian Department of Communications.

Cet appareil numérique n'émet pas de bruits radioélectriques dépassant les limites de classe A et B prescrites dans la norme NMB-003 édictée par le Ministre des Communications du Canada.

 **DANGER**

**THIS PRODUCT CONTAINS CHEMICALS KNOWN TO THE STATE OF CALIFORNIA TO CAUSE CANCER AND/OR BIRTH DEFECTS OR OTHER REPRODUCTIVE HARM.**

Operation, installation, and servicing of this product could expose you to airborne particles of glasswool or ceramic fibers, crystalline silica, and/or carbon monoxide. Inhalation of airborne particles of glasswool or ceramic fibers is known to the State of California to cause cancer. Inhalation of carbon monoxide is known to the State of California to cause birth defects or other reproductive harm.

**NOTICE**

The Commonwealth of Massachusetts requires any and all gas products and/or products attached to a water supply to be installed by a licensed plumber or pipe fitter.

 **DANGER**

Do not use a water jet to clean this appliance.

 **WARNING**

Raise the lid slowly. Trapped steam may escape from beneath the lid.

**NOTICE**

All units shipped without factory supplied cords and plug assemblies must be hardwired using flexible conduit to the terminal block located on the rear of the unit. These units should be wired to NEC specifications. Hardwired units must include installation of restraint devices.

** DANGER**

Adequate means must be provided to limit the movement of this appliance without depending on or transmitting stress to the electrical conduit. A restraint kit is provided with the fryer. If the restraint kit is missing contact your local Frymaster Factory Authorized Servicer (FAS) for part number 810-3574.

**NOTICE**

If this equipment is wired directly into the electrical power supply, a means for disconnection from the supply having a contact separation of at least 3-mm in all poles must be incorporated in the fixed wiring.

**NOTICE**

This equipment must be positioned so that the plug is accessible unless other means for disconnection from the power supply (e.g., a circuit breaker) is provided.

**NOTICE**

If the electrical power supply cord is damaged, it must be replaced by a Frymaster Dean Factory Authorized Servicer technician or a similarly qualified person in order to avoid a hazard.

**NOTICE**

If this appliance is permanently connected to fixed wiring, it must be connected by means of copper wires having a temperature rating of not less than 167°F (75°C).

# FE155 Rethernalizer

## Service and Parts

### TABLE OF CONTENTS

Annotated Views	1-1, 1-2
Control Operation	1-3
Functional Description, Wiring Diagram	1-4, 1-5
Component Replacement	1-5, 1-7
Parts	2-1



# CHAPTER 1: Overview/Component Replacement

## 1.1 Finding Your Way around the FE155

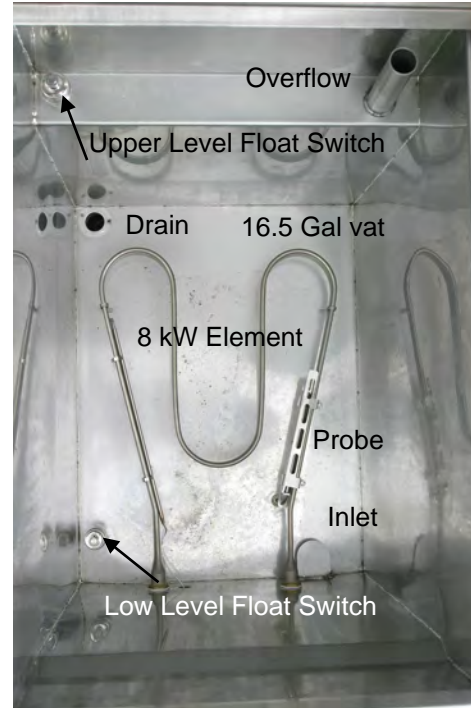

FE155 Vat

**NOTE:** The water inlet is controlled by the main power switch. It must be off during draining and cleaning to ensure the vat doesn't refill.

FE155 (Chili's model shown with unique bezel)

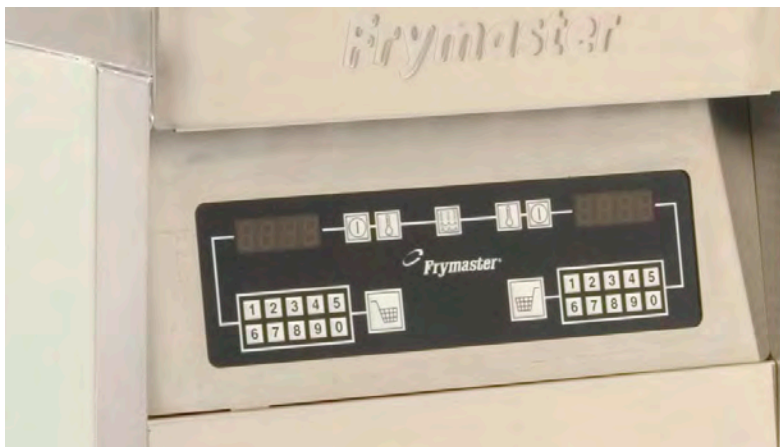

Controller with standard bezel

# CHAPTER 1: Overview/Component Replacement

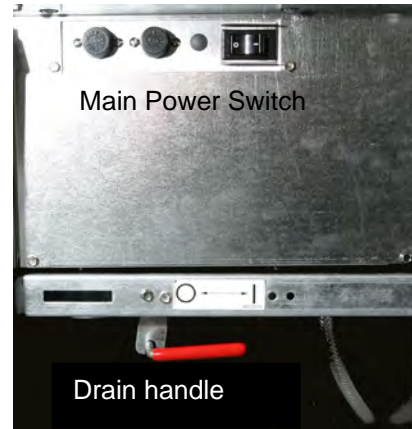
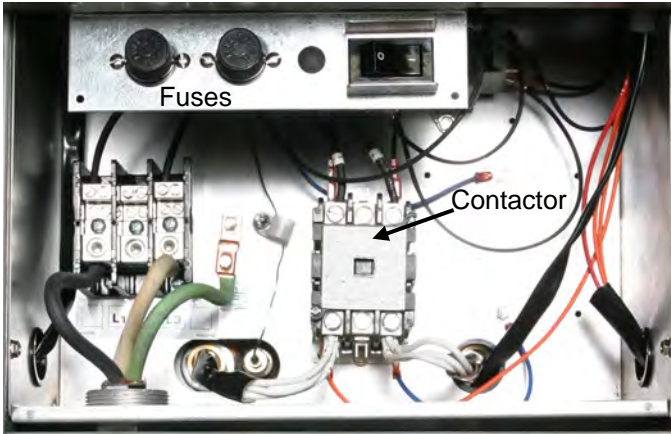

Cabinet Interior

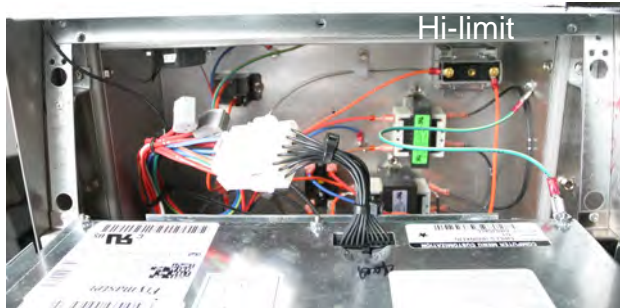
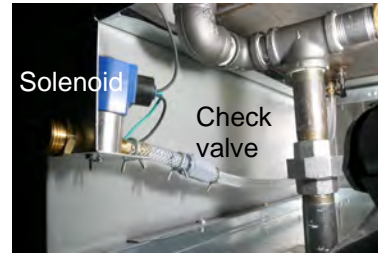
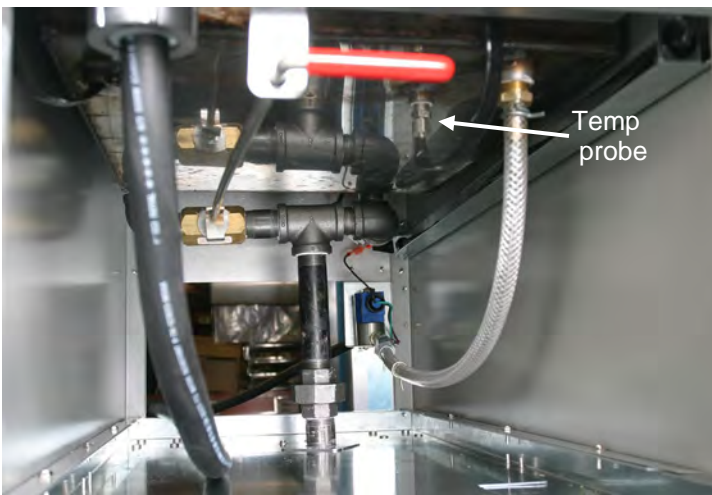

Inside control box



Drain extension



# CHAPTER 1: Overview/Component Replacement

## 1.2 Controller

This equipment uses a specialized controller. Chili's has a bezel that covers part of the controller to restrict access. Instructions for it are below.

**Displays:** at setpoint alternate between dashed lines, 5 min. LO is displayed below setpoint, BOIL when the boil key is pressed.

**Temperature Keys:** pressing either key displays actual temperature on the left, setpoint on the right, alternating with 5 min. Press again to toggle to original display.

**NOTE:** In boil mode the temperature is not displayed and the temperature buttons are inactive.

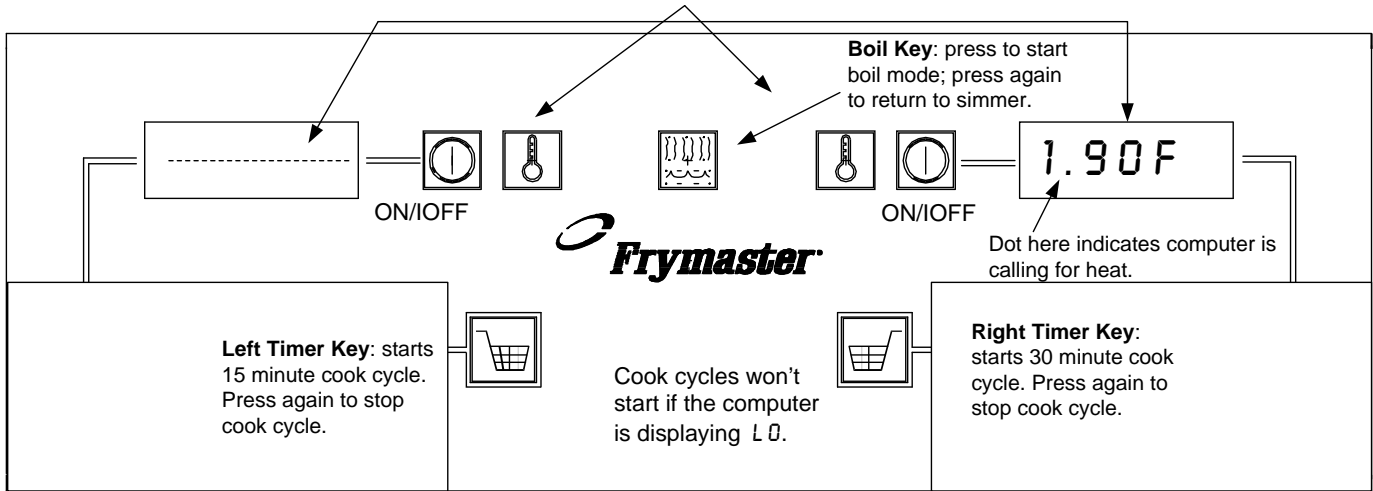

The general market has a different bezel and access to additional keys as shown below.

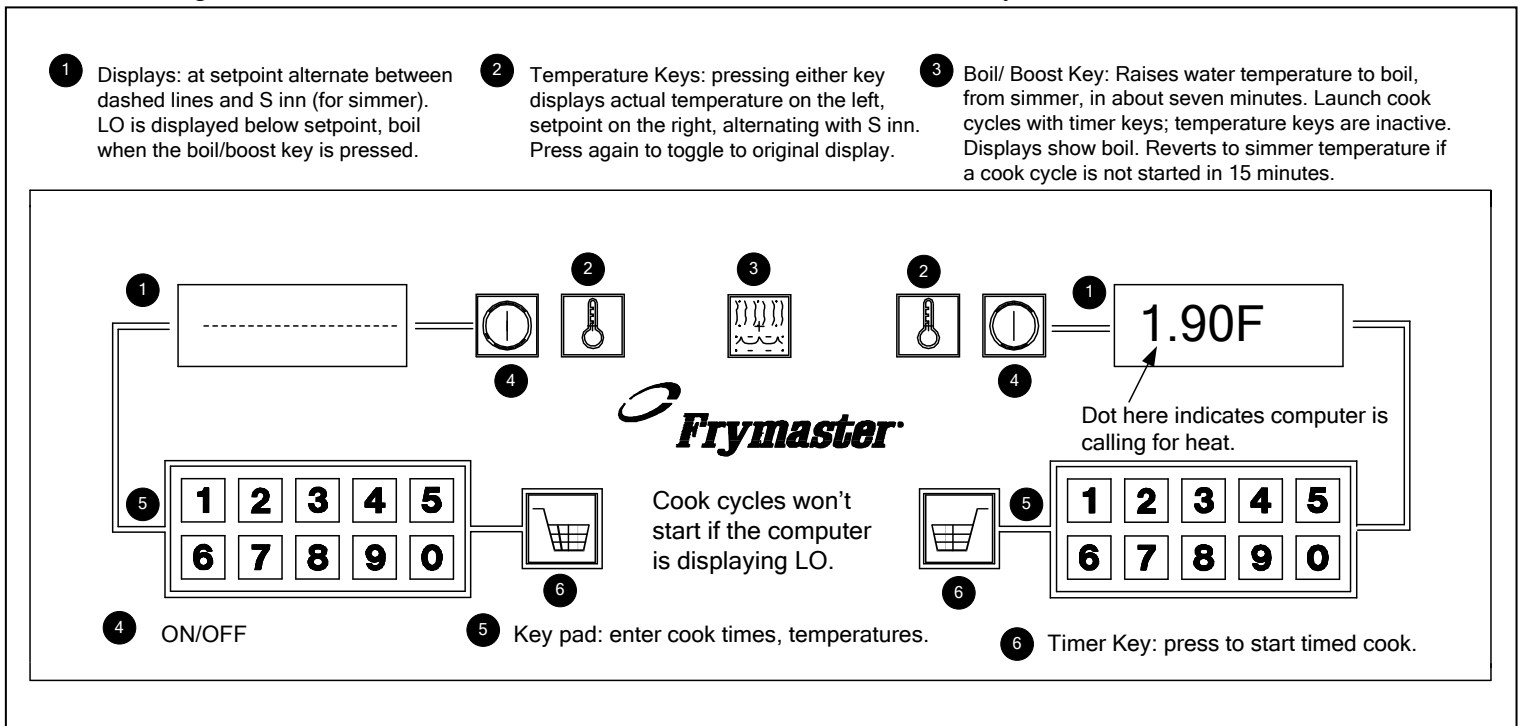

### Computer Operation

- Ensure the main power switch (behind cabinet door) is on.
- Press either ON/OFF button to turn the computer on.
- The computer displays LO as it rises to the preset 190°F setpoint for simmer.

# CHAPTER 1: Overview/Component Replacement

- At setpoint, the computer displays alternate between dashed lines, and 5 inr.
- Press a Temperature key to toggle display to actual temperature on the left, setpoint on the right. Press again to toggle back.

## Simmer

- Place product in vat and press desired timer key. Display alternates between 5 inr and remaining cook time.
- C O O C appears and an alarm sounds when the cook time elapses. Cook cycles won't start if the computer is displaying LO.
- Remove the product and press the timer key to halt the alarm.

**NOTE:** Computer returns to simmer mode if a boil cook cycle is not initiated within 15 minutes of pressing the boil key.

## Boil

- Press the boil key.
- Display changes to B O I L .
- Wait until water boils.
- Place product in vat and press the desired timer key. Temperature keys are inactive.
- Display alternates between boil and the remaining cook time.
- C O O C appears and an alarm sounds when the cook time elapses.
- Remove the product and press the timer key to halt the alarm.
- Press Boil key a second time to return to simmer mode.

**NOTE:** Pressing the Boil key with the computer OFF produces a Code display. ON/OFF keys are inactive.  
— Enter 1661 to display the software version and reactivate the ON/OFF keys.  
— Press any other key four times to clear display and reactivate ON/OFF keys without software display.

## 1.3 Programming

- **Remove the bezel** (see annotated photo on page 3-1) Lift up and then rotate out at the bottom, which exposes a keypad beside each timer button.
- **Temperature change:** Press the temperature key until the current temperature is displayed. Enter the desired temperature with the key pad.
- An illuminated dot between the last digit and the F indicates the change was accepted. Temperatures below 155°F and above 210°F can't be entered. The computer will default to its lowest setting, 155°F, upon low-temperature entry and to its highest setting, 210°F, upon high-temperature entry.
- **Time change:** Press the temperature key until the display alternates between 5 inr and a dashed line. Enter the desired time, in minutes and seconds, on the key pad. Press the timer key to ensure the desired time is in place. Press the timer key a second time to stop the timer.
- **Turn the controller OFF.** Replace the bezel. Ensure it doesn't press against the key pads.

## 1.4 Functional Description

With the main power-switch on, 24-volts is supplied to a relay, which controls the water solenoid. If the upper float switch is closed (low-water position), the relay is closed and the solenoid opens. It is not necessary for the controller to be on for the pot to fill.

Twelve volts is also supplied to the controller. The low-level float switch must close to allow signals from the controller to reach a relay, which, when closed, sends 24 volts through the high limit to the contactor. The unit won't heat with the float switch open.

With the controller on, the temp probe monitors the water temperature. The controller calls for heat, when necessary, by closing the 24-volt relay, which closes the contactor and energizes the elements.

# CHAPTER 1: Overview/Component Replacement

## Field Connection Wiring Diagrams

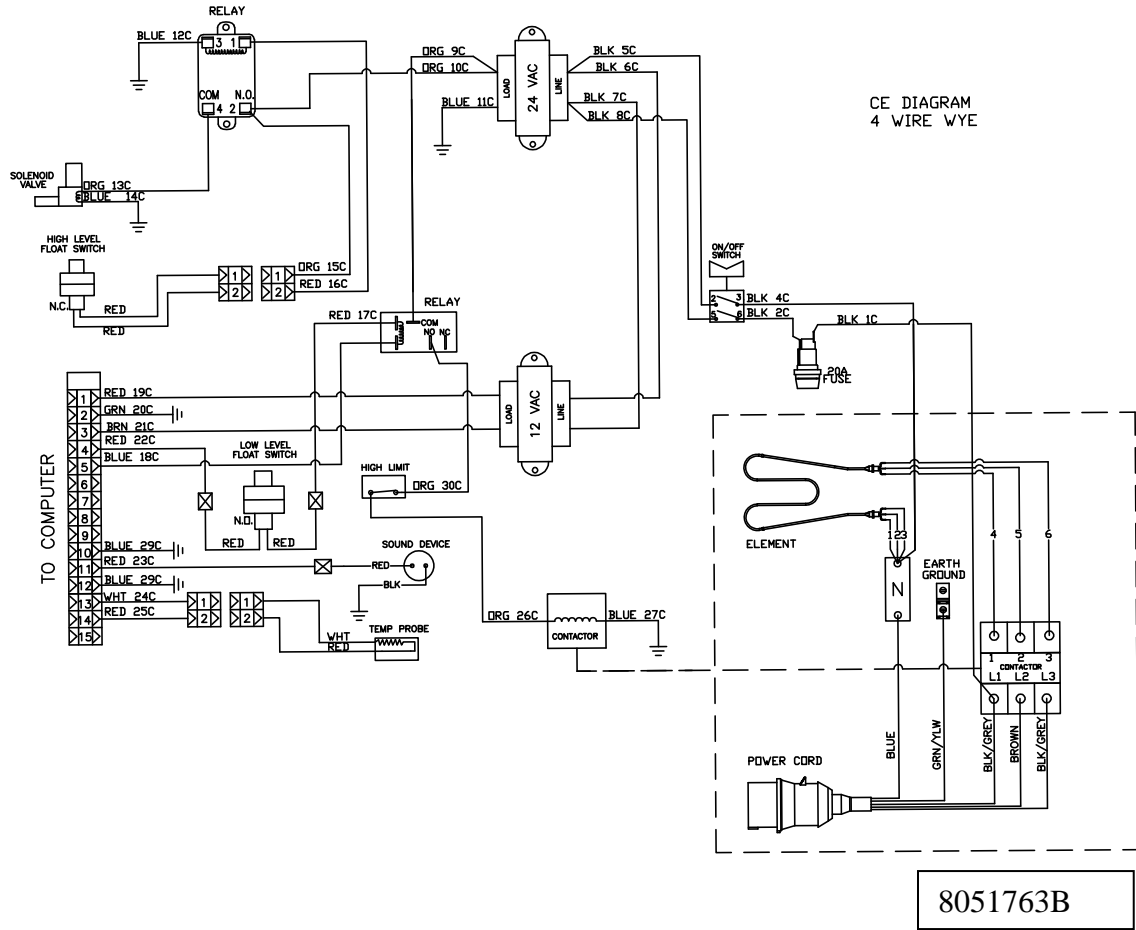
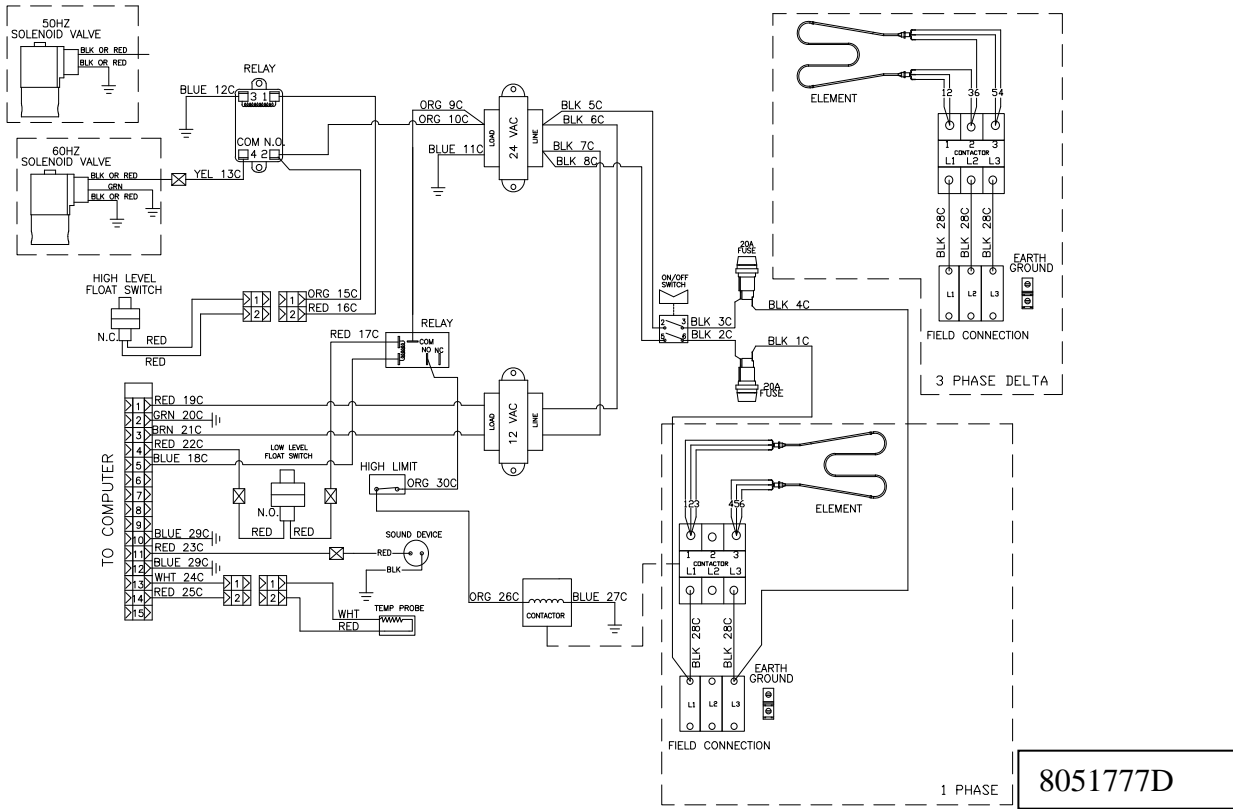

# CHAPTER 1: Overview/Component Replacement

## 1.5 Replacing the Element

1. Drain the cookpot and disconnect the cooker from the electrical power supply.
2. Remove the cover from the component box.
3. Make a note of where the leads are connected to the contactor block; disconnect the leads.
4. Cut the wire ties on the fiberglass insulation and remove the insulation from the element leads.
5. Cut the metal wire ties which secure the high-limit thermostat to the element, being careful not to bend the thermostat.
6. Remove temperature probe.
7. Remove the brass nuts from the element legs and carefully pull the failed element from the cookpot.
8. Position the replacement element in the cookpot with the standoffs on the bottom of the cookpot, and thread the element leads through the Teflon washers provided in the element kit. Secure the element in place with the nuts and zinc washers provided in kit.
9. Install two metal wire ties to secure the high-limit thermostat against the inside of the left leg of the element.
10. Reposition the temperature probe in its bracket and attach it to the inner right leg of the element.
11. Thread each set of element leads through the fiberglass insulation removed in Step 4 and secure the insulation in place with a wire tie as close as possible to the brass nut.
12. Thread the leads into the component box and connect them to the contactor block in accordance with the notes made in Step 3 or the wiring diagram on the door.
13. Replace the cover on the component box. Reconnect the unit to the electrical power supply.

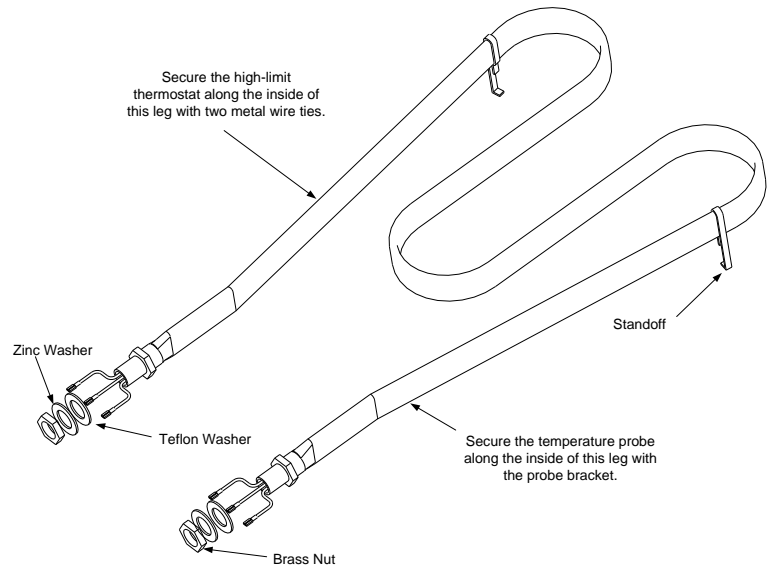

## 1.6 Replacing the High-Limit Thermostat

1. Drain the cookpot and disconnect the cooker from the electrical power supply.
2. Cut the metal wire ties securing the thermostat body to the element.
3. Press up on the bezel over the computer and pull out at the bottom to remove it.
4. Remove the screws securing the controller and unplug it from its harness.
5. Mark and then disconnect the two leads connected to the thermostat terminals.
6. Loosen the small compression nut, and unscrew the large fitting from the cookpot.
7. Remove the screws securing the thermostat. Pull the thermostat from the cookpot.
8. Insert the replacement thermostat into the cookpot, being careful not to bend the shaft.
9. Position the thermostat along the inside of the left leg of the element and secure it in place with two metal wire ties.

# CHAPTER 1: Overview/Component Replacement

10. Unscrew the small compression nut from the large fitting on the replacement thermostat. Apply thread sealer to the large fitting and screw the fitting securely into the cookpot. When the large fitting is tight, screw the small compression nut into the large fitting and tighten.
11. Coil the thermostat capillary tube as necessary to achieve a neat installation and attach the terminal block to the mounting bracket.
12. Reattach the leads disconnected in Step 5, being sure to reconnect them in accordance with the wiring diagram on the door of the unit or the markings made when they were disconnected.
13. Return the controller; ensure its harness is fully connected. Secure it with the screws removed in Step 4.
14. Reconnect the unit to the electrical power supply.

## 1.7 Replacing the Temperature Probe

1. Drain the cookpot and disconnect the cooker from the electrical power supply.
2. Remove the baskets, basket rack.
3. Mark the wiring harness leads and disconnect them from the probe leads at the push-on connectors.
4. Remove the two screws in the probe bracket.
5. Loosen the small compression nut, and unscrew the large fitting from the cookpot.
6. Carefully pull the probe from the probe block and replace with the new probe.
7. Reattach the leads and reverse Steps 1-5 to complete the procedure, using thread sealer to prevent leaks.

## 1.8 Replacing a Float Switch

**NOTE:** The high-level float switch (106-8007) is normally closed. The low-level float switch (106-9389) is normally open. A kit, 826-2622, contains one float switch that can be used for either position by flipping the float, which changes its condition.

1. Drain the cookpot and disconnect the cooker from the electrical power supply.
2. Remove the baskets, basket rack.
3. Remove the nut securing the float switch.
4. Remove the connecting pins from the harness and lift the float from its position.
5. Route the wires of the replacement float switch through the cabinet and connect them. Remove the float from the float switch kit, if necessary. Ensure it is positioned properly for the high-level position (normally closed) or for the low-level position (normally open).
6. Secure the new float switch, using thread sealer to prevent leaks.
7. Reposition the rethermalizer and allow it to fill to test the float switch operation.



High-level float switch

# FE155 Rethermalizer

## CHAPTER 2: PARTS LIST

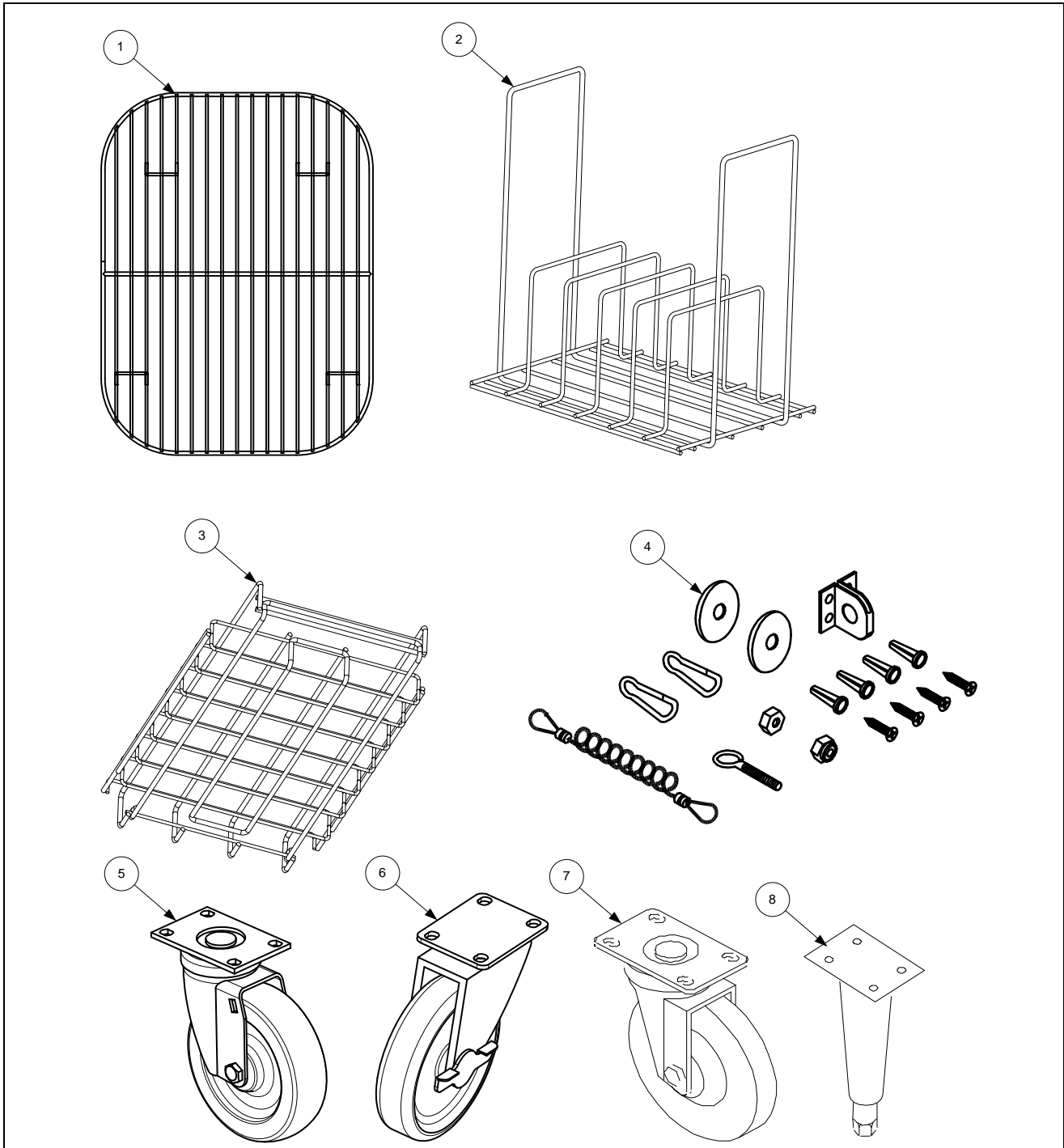

### Accessories

Item	Part #	Component
1	803-0384	Rack, support
2	803-0385	Rack, master (use 803-0407 for Chipolte's)
3	803-0386	Basket, insert (use 803-0406 for Chipolte's)
4	810-3574	Restraint kit
5	810-0356	Caster, 5-in, no brake (Used on all units with 4 casters)
6	810-0357	Caster, 5-in, brake (Used on all units with 4 casters)
7	810-0750	Caster, 5-in, rigid (Used on all units with 2 casters and 2 legs)
8	810-3168	Leg

# FE155 Rethernalizer

## CHAPTER 2: PARTS LIST

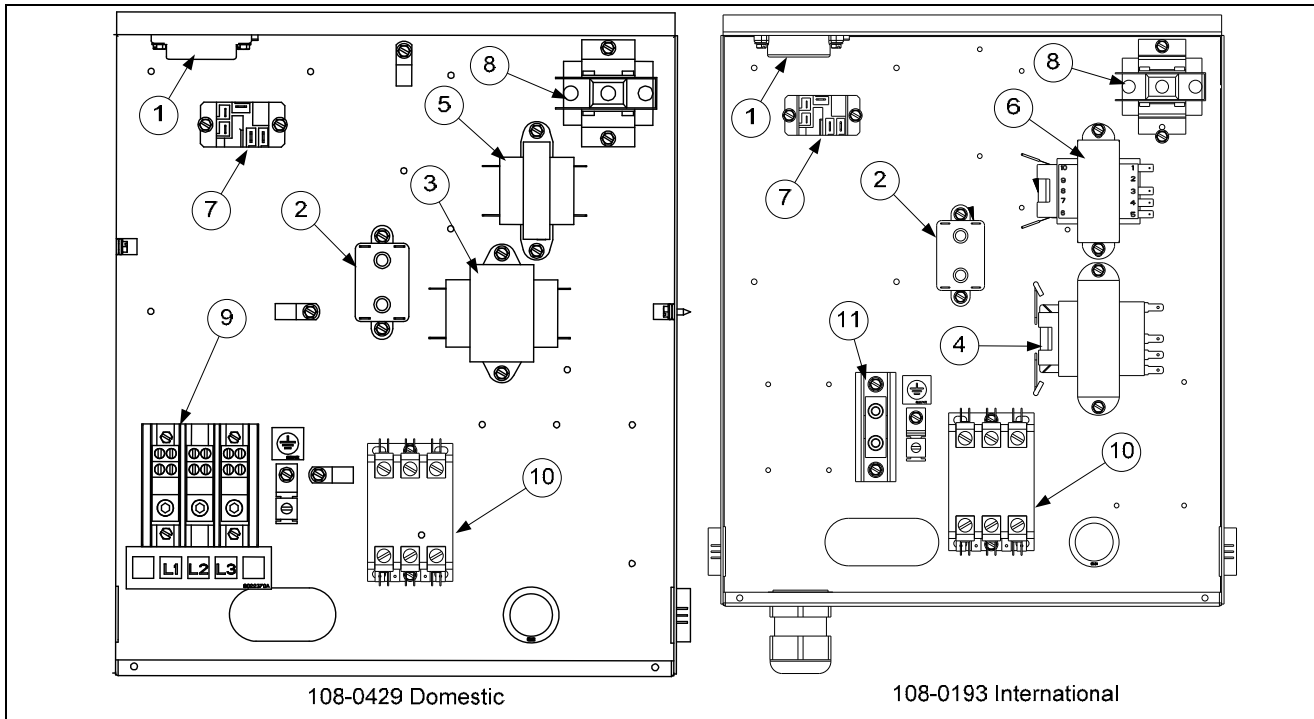

### Contactor Box

Item	Part #	Component
1	108-0039	Sound Device
2	807-0012	Relay, 18 amp, 24V coil
3	807-0680	Transformer, 208/240/24V 50/60Hz, 43VA
4	807-2180	Transformer, 208/240/24V 50/60Hz, 50VA (Intl.)
5	807-0979	Transformer, 208/240/12V, 50/60Hz, 20VA
6	807-2191	Transformer, 208/230/240/12V 50/60Hz, 30VA (Intl.)
7	807-1683	Relay, 12VDC
8	826-1601	Thermostat, Hi-Limit
9	807-3970	Block, 3-pole 600V 175A
10	807-2284	Contactor, 3-pole 600V 50 amp
11	807-1268	Splicer, Terminal Block Single Pole
*	807-4751	Cord set, Single Phase
*	807-3586	Cord set, Three Phase
*	807-0922	Fuse Holder
*	807-2278	Fuse, 20 amp
*	807-4036	Switch, on-off

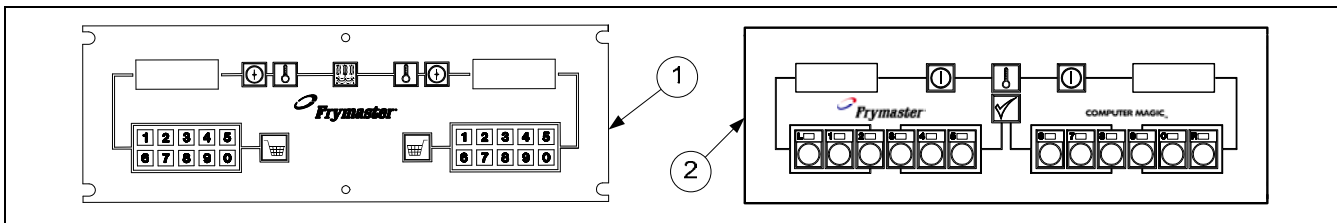

### Controller

Item	Part #	Component
1	108-0274	FE155 Controller (2 timers)
2	106-9915	FE155 Controller (10 timers)
*	807-4397	Harness, controller

# FE155 Rethermalizer

## CHAPTER 2: PARTS LIST

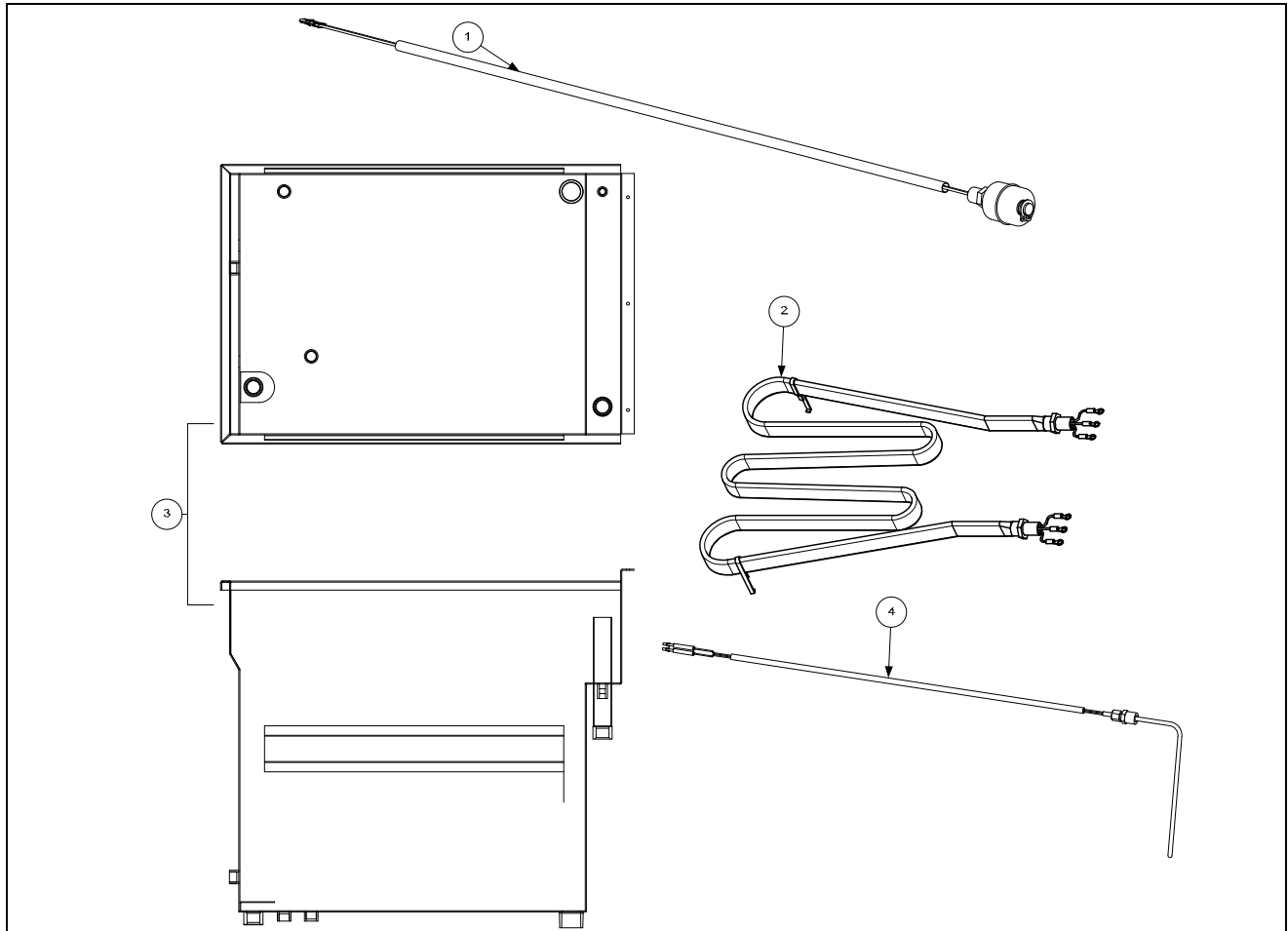

### Vat, Related Components

Item	Part #	Component
1	826-2622	Float switch, kit
*	826-2705	Snap ring clip (Pkg. 5)
*	813-0807	Bushing, ¼ MNPT x 1/8 FNPT for lower float switch
2	826-2623	Element kit, 240V
3	823-6263	Vat
4	826-2624	Temperature probe kit
*	809-0204	Washer, Teflon for elements
*	230-3071	Bracket, temp probe
*	230-4539	Bracket, temp probe, strap
*	230-0500	Strap, temp probe
*	809-0500	½" screw, SS, probe bracket

\* Not Illustrated.

# FE155 Rethermalizer

## CHAPTER 2: PARTS LIST

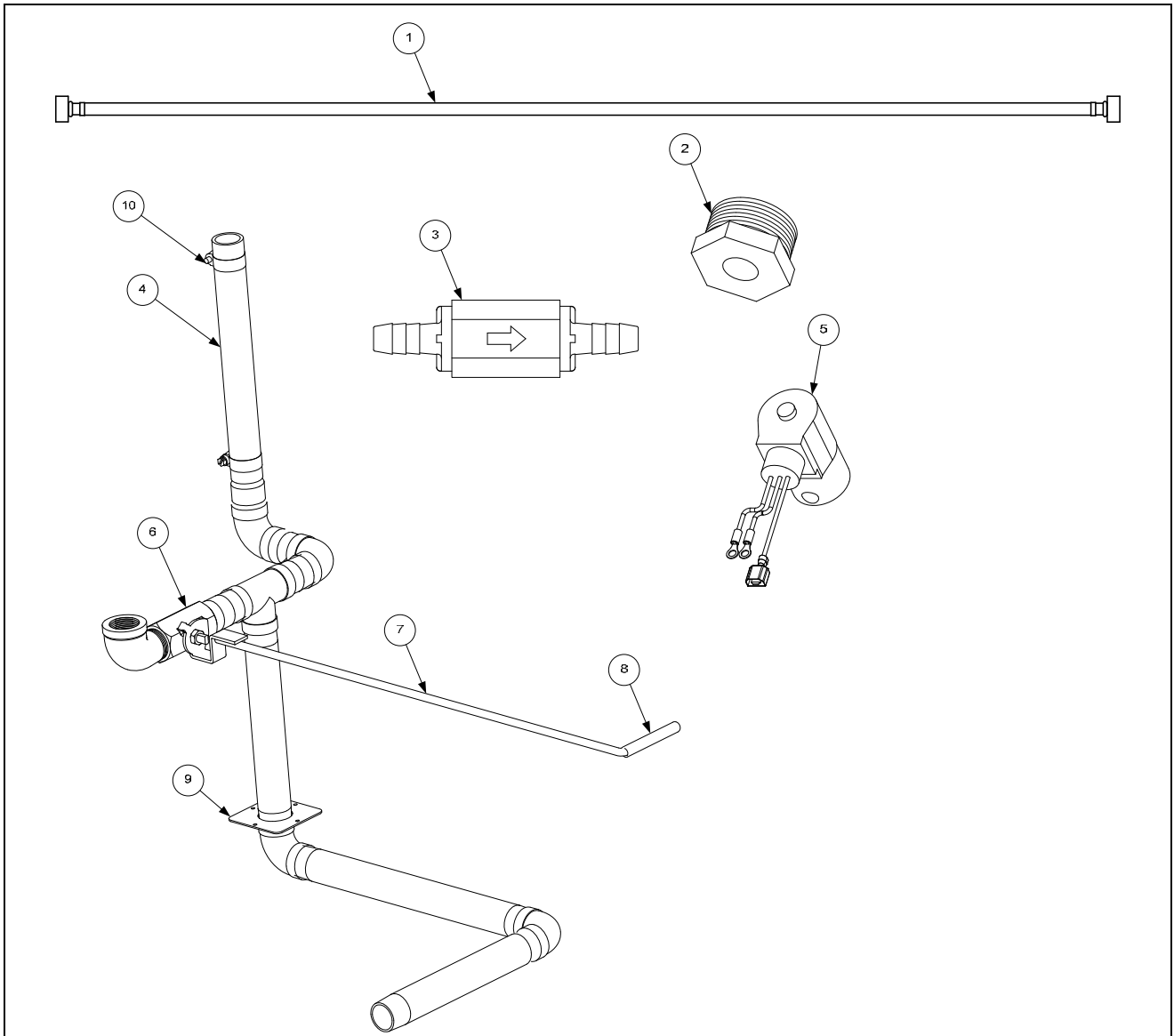

### Drain, Fill Components

Item	Part #	Component
1	810-3572	Hose, water connection, 48"
2	810-3573	Adapter, hose to pipe 1/4 x 3/4 "
3	810-3243	Check valve, in-line
4	816-0779	Hose, drain
5	108-0435	Solenoid, water inlet
6	810-3569	Valve, drain, brass 1"
7	823-6279	Handle, drain
8	816-0639	Cap, vinyl
9	220-5585	Plate, drain base cover
10	810-3244	Clamp, 5/8" hose
*	811-1141	Tubing, 3/8 "

\* Not Illustrated.

# FE155 Rethermalizer

## CHAPTER 2: PARTS LIST

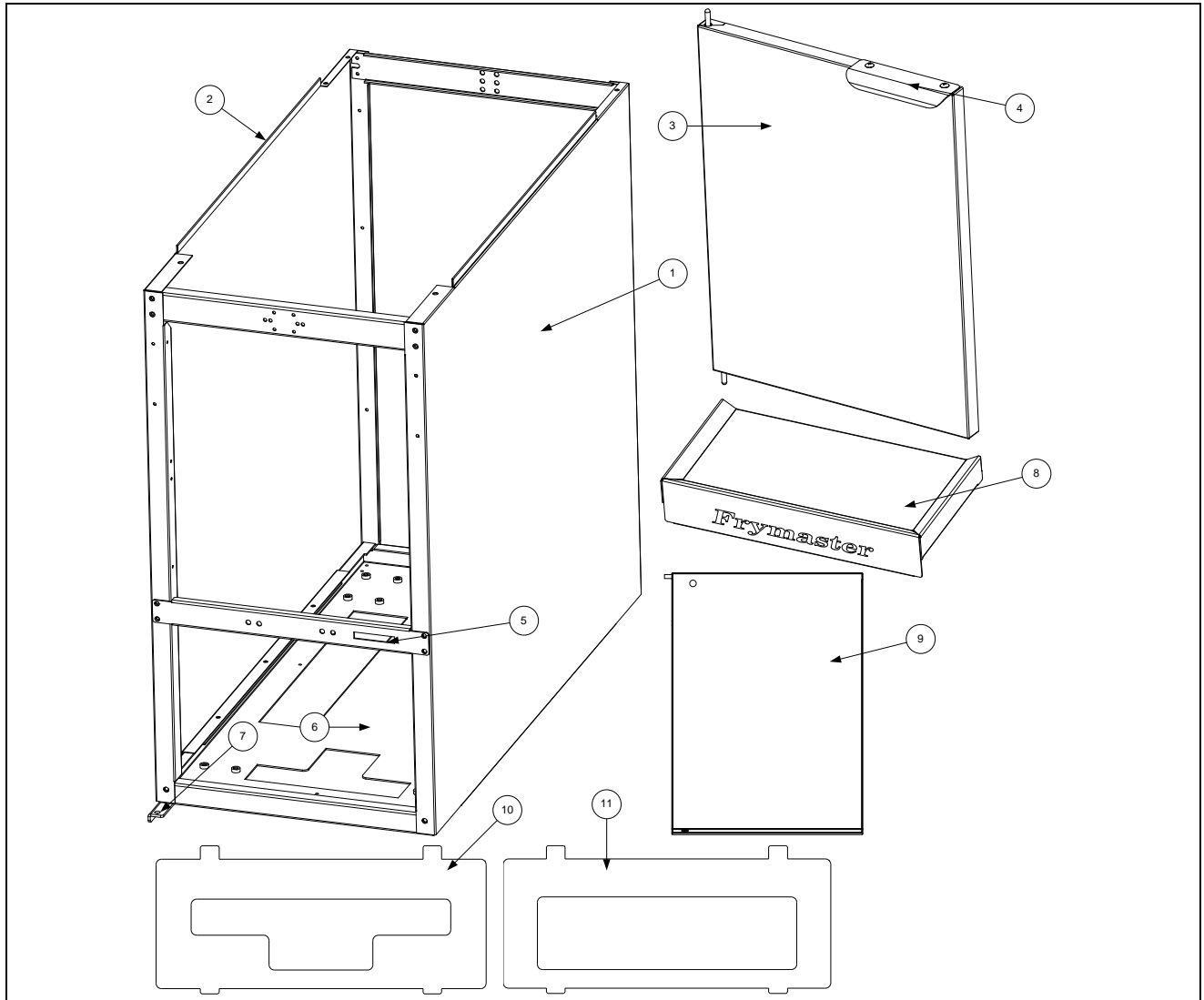

### Cabinet Components

Item	Part #	Component
1	231-4530	Cabinet side, Stainless
2	232-4530	Cabinet side, Stainless
3	108-0262	Door
4	230-5472	Handle
5	810-2346	Magnet, door
6	220-5588	Cabinet base
7	230-4998	Hinge, lower
8	823-7041	Topcap (use 824-2195 for Chipolte's)
9	823-7119	Vat cover
10	230-5479	Bezel, Chili's
11	230-4519	Bezel, Standard
*	810-1374	Handle, cover
*	809-0603	Screw, 3/8x24, handle cover
*	106-9744	Hinge assembly, cover, right
*	106-9745	Hinge assembly, cover, left

\* Not Illustrated.

# *Frymaster*®

FRYMASTER  
8700 LINE AVENUE, SHREVEPORT, LA 71106-6800

800-551-8633  
318-865-1711  
[WWW.FRYMASTER.COM](http://WWW.FRYMASTER.COM)  
EMAIL: [FRYSERVICE@WELBILT.COM](mailto:FRYSERVICE@WELBILT.COM)



Welbilt offers fully-integrated kitchen systems. Welbilt's portfolio of award-winning brands includes Cleveland™, Convotherm®, Crystal Tips®, Dean®, Delfield®, Fabristeel®, Frymaster®, Garland®, Inducs®, Koldtech®, Kolpak®, Lincoln®, McCann's™, Merco®, Merrychef®, Multiplex®, RDI®, SerVend™, SunFire®, U.S. Range™, and WMaxx™. Supported by service brands: FitKitchen®, kitchen systems; and KitchenConnect®, cloud-based open platform.

*Bringing innovation to the table* • [welbilt.com](http://welbilt.com)

©2023 Frymaster LLC. except where explicitly stated otherwise. All rights reserved. Continuing product improvement may necessitate change of specifications without notice.

Part Number FRY\_SP\_8196440 06/2023