

Frymaster[®]

Your Growth Is Our Goal

FilterQuick™ FQE30 Electric Fryer

Wiring Diagrams

This manual is updated as new information and models are released. Visit our website for the latest manual.



8 1 9 7 2 2 5

Part Number: FRY_D_8197225 08/2023



 **DANGER**

Prior to movement, testing, maintenance and any repair on your Frymaster fryer, disconnect ALL electrical power from the fryer.

FILTERQUICK™ FQE30 SERIES ELECTRIC FRYER

Table of Contents

SECTION 1: Wiring Diagrams

1.1	Control Wiring 08/2022-Present	1-1
1.2	Control Wiring Prior to 08/2022	1-2
1.3	Contactor Box – Delta Configuration	1-3
1.4	Contactor Box – Delta Configuration 14kW/17kW EPRI/TRIAC	1-4
1.5	Contactor Box – WYE Configuration.....	1-5
1.6	Contactor Box – WYE Configuration 14kW/17kW EPRI/TRIAC.....	1-6
1.7	Simplified Wiring	1-7
	1.7.1 Simplified Wiring with Push Button	1-7
	1.7.2 Simplified Wiring with Push Pull Handles	1-8
1.8	Shortening Melting Unit	1-9
1.9	Modular Basket Lift 100-120V	1-10
1.10	Modular Basket Lift 208-250V	1-11
1.11	Modular Basket Lift 480V – (After Feb. 2019) (Modular).....	1-12
1.12	Modular Basket Lift 200V-250V - (After April 2014) (Modular)	1-13

FILTERQUICK™ FQE30 SERIES ELECTRIC FRYER

SECTION 1: WIRING DIAGRAMS

1.1 Control Wiring 08/2022 to present

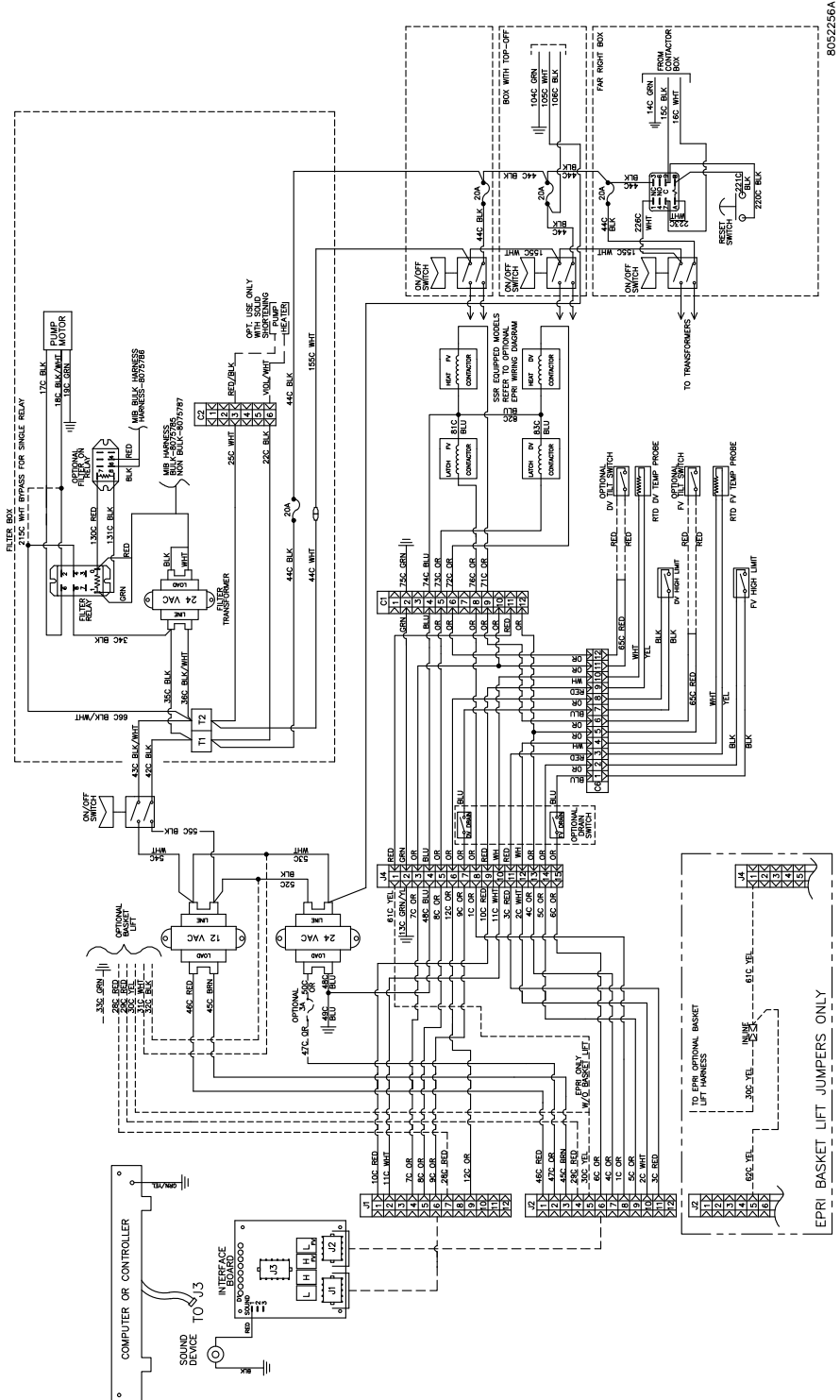

1.3 Contactor Box – Delta Configuration

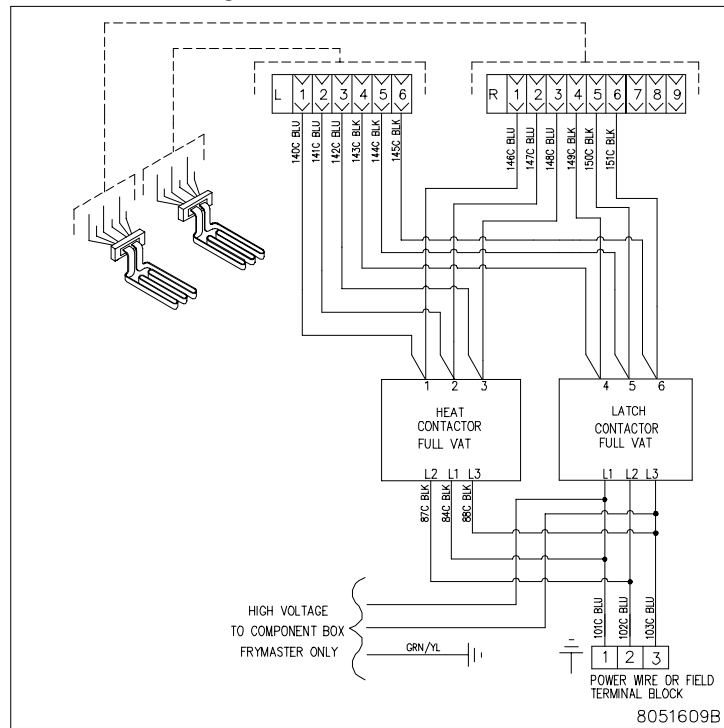

FULL VAT

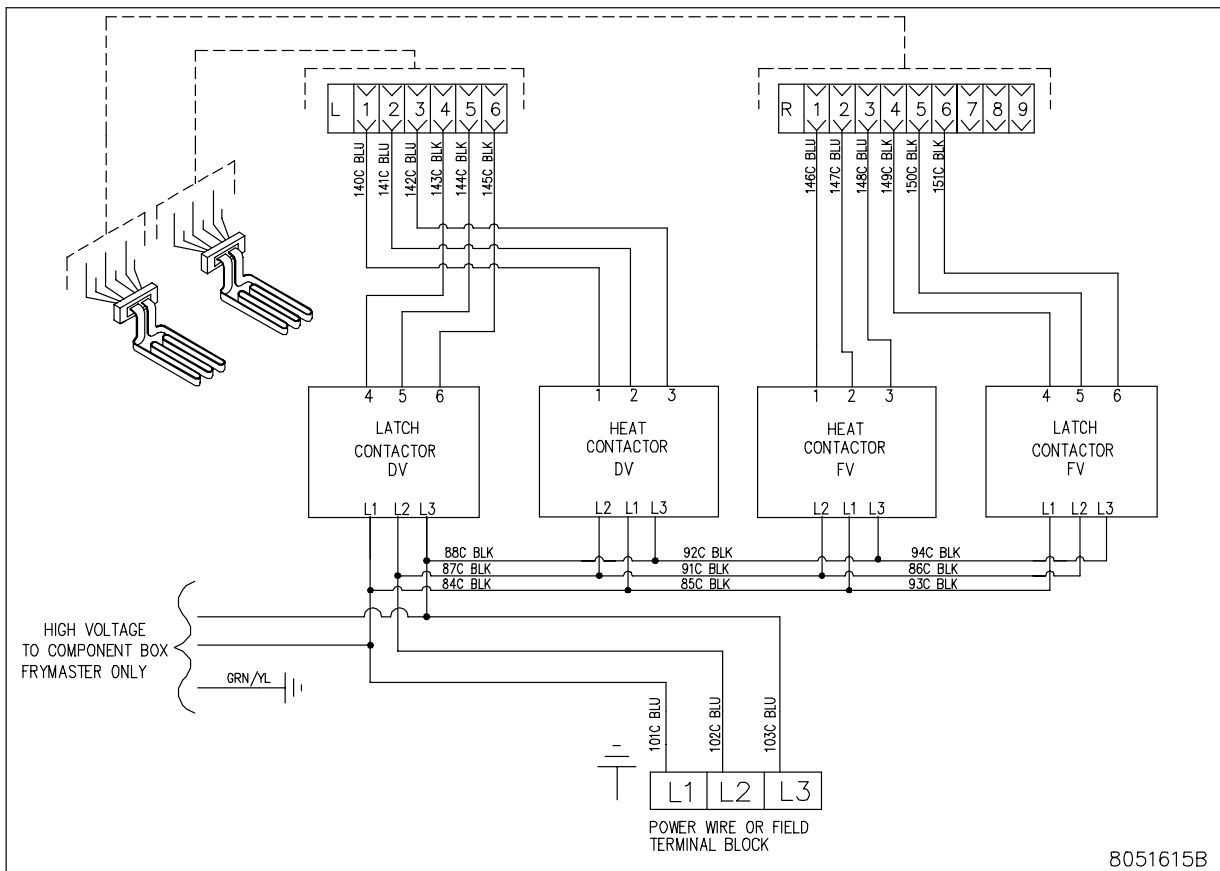

DUAL VAT

1.4 Contactor Box – Delta Configuration 14kW/17kW EPRI/TRIAC

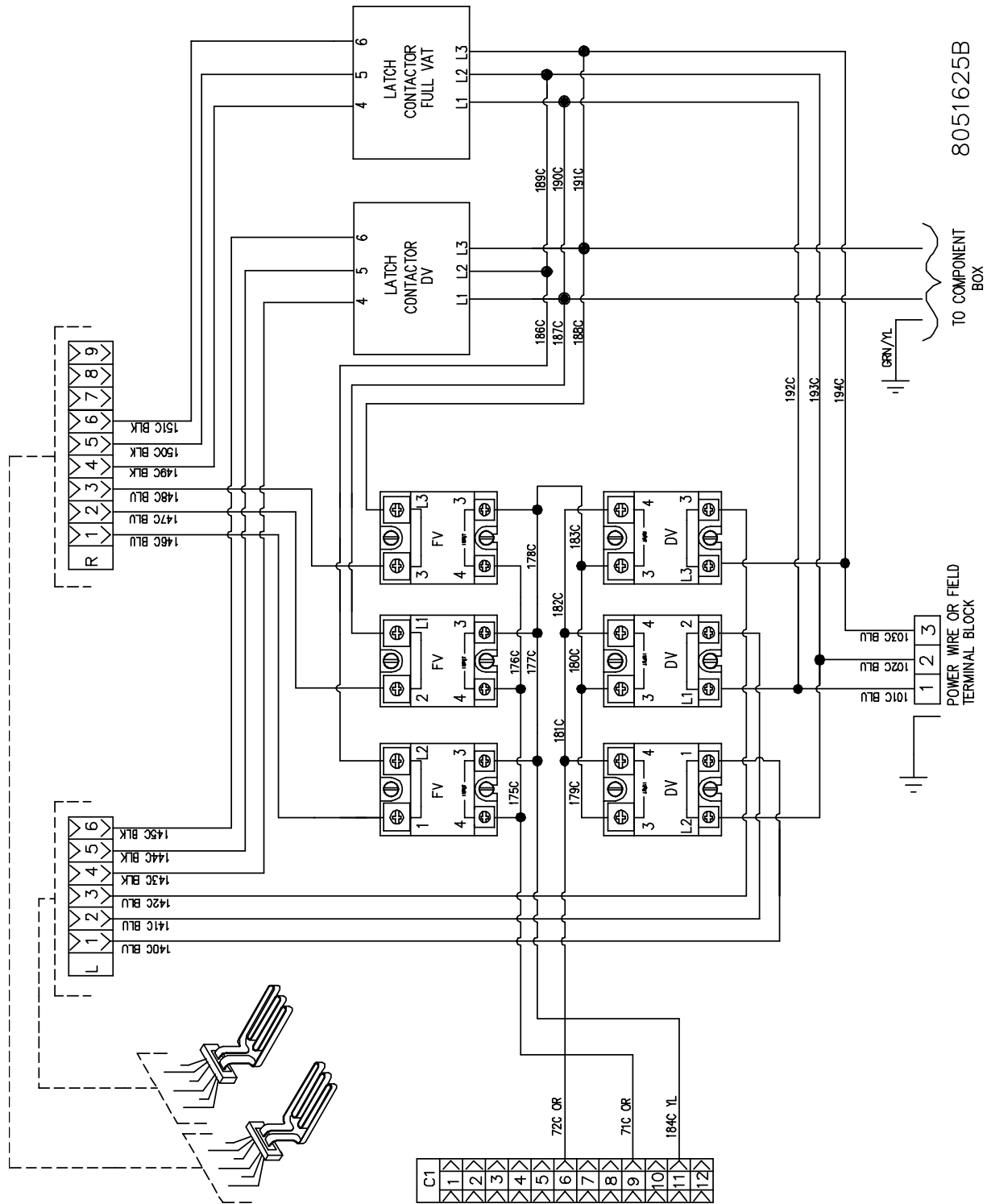

14kW / 17kW EPRI/TRIAC SSR ELEMENT WIRING

8051625B

TO COMPONENT BOX

POWER WIRE OR FIELD TERMINAL BLOCK

1.5 Contactor Box – WYE Configuration

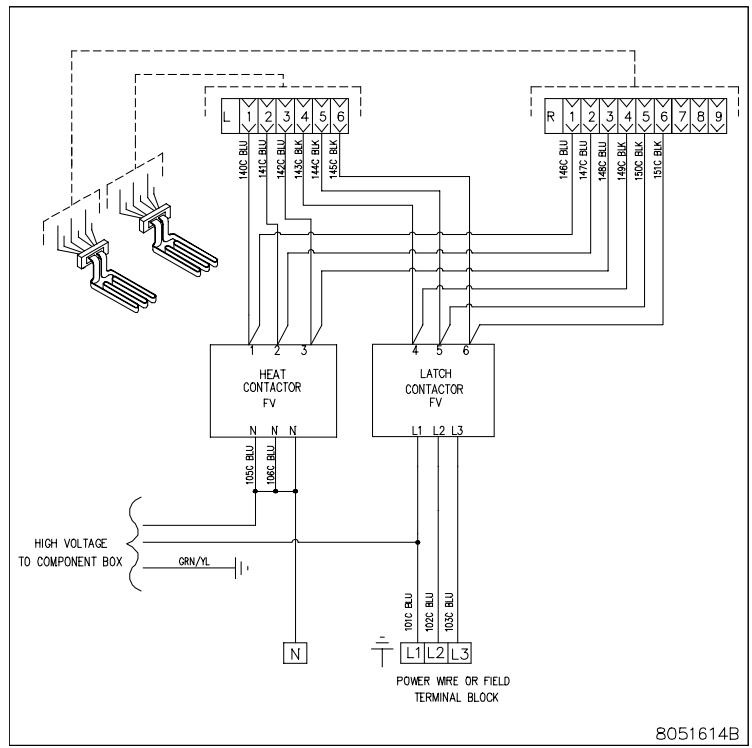

FULL VAT

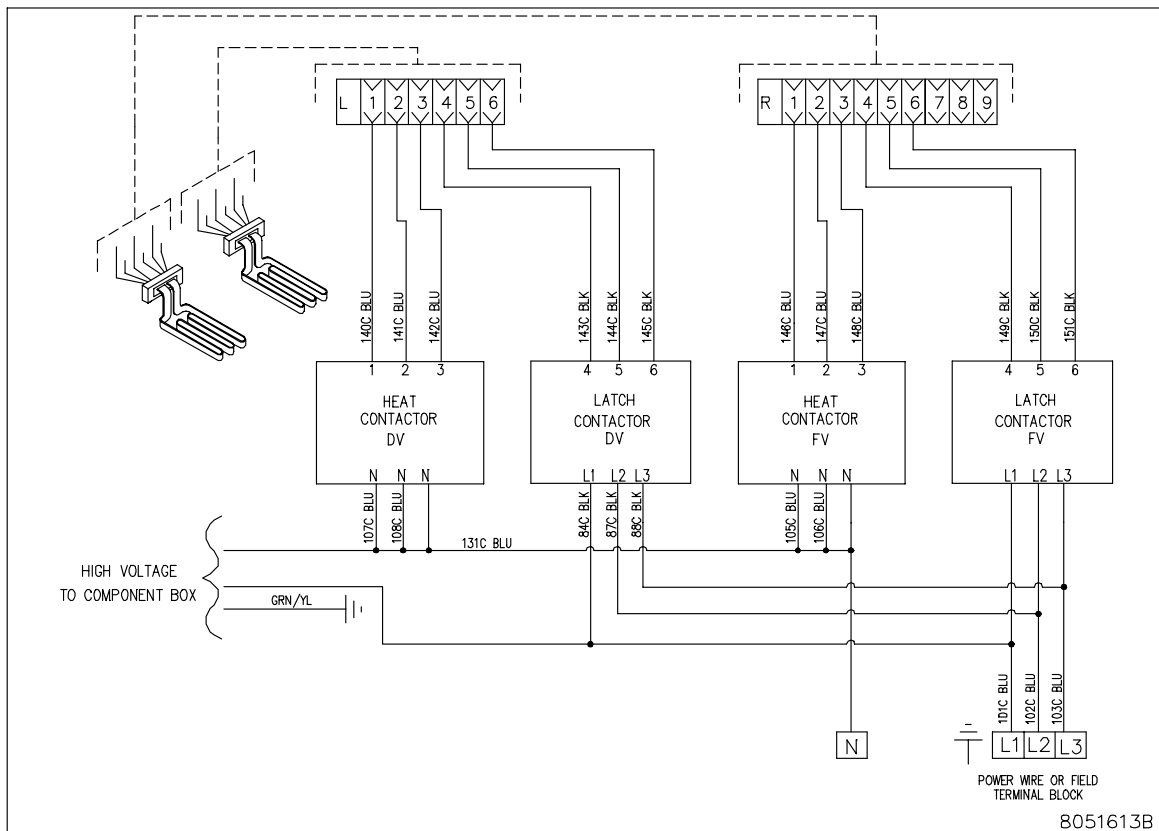

DUAL VAT

1.6 Contactor Box – WYE Configuration 14kW/17kW EPRI/TRIAC

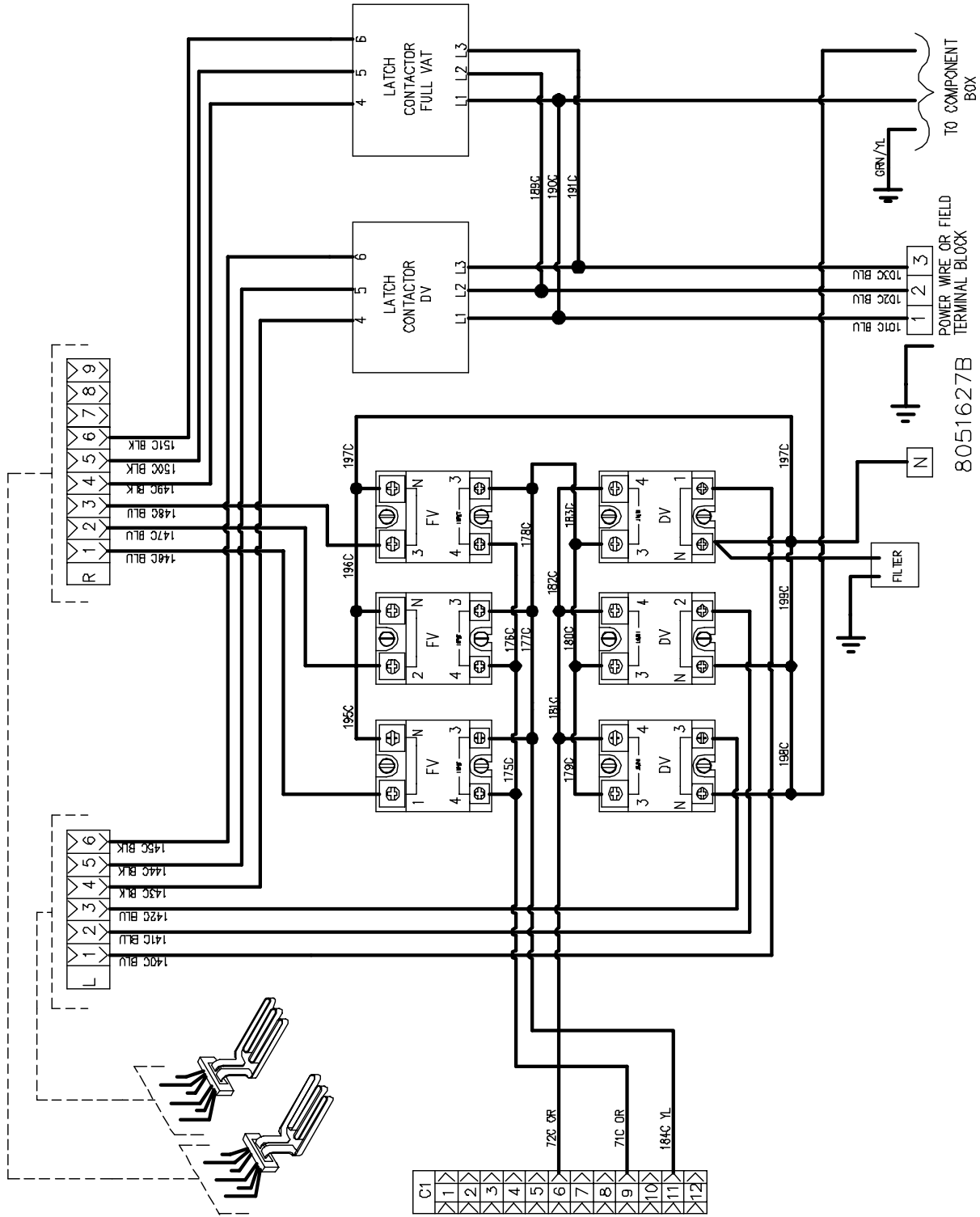

14kW / 17kW EPRI/TRIAC SSR ELEMENT WIRING

1.7 FilterQuick™ Electric Simplified Wiring

1.7.1 FilterQuick™ Electric Simplified Wiring with Push Button

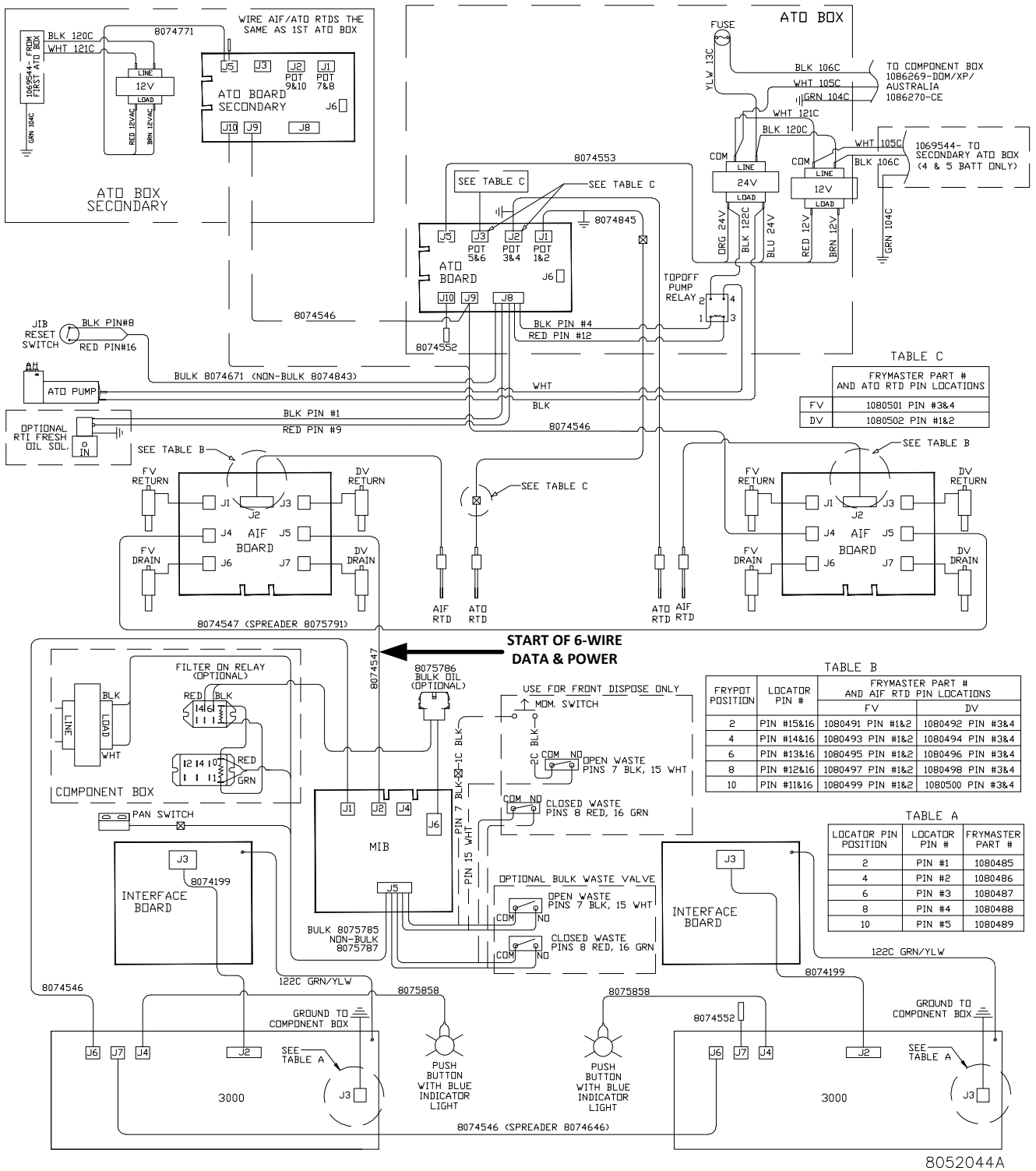

1.7.2 FilterQuick™ Electric Simplified Wiring with Push Pull Handles

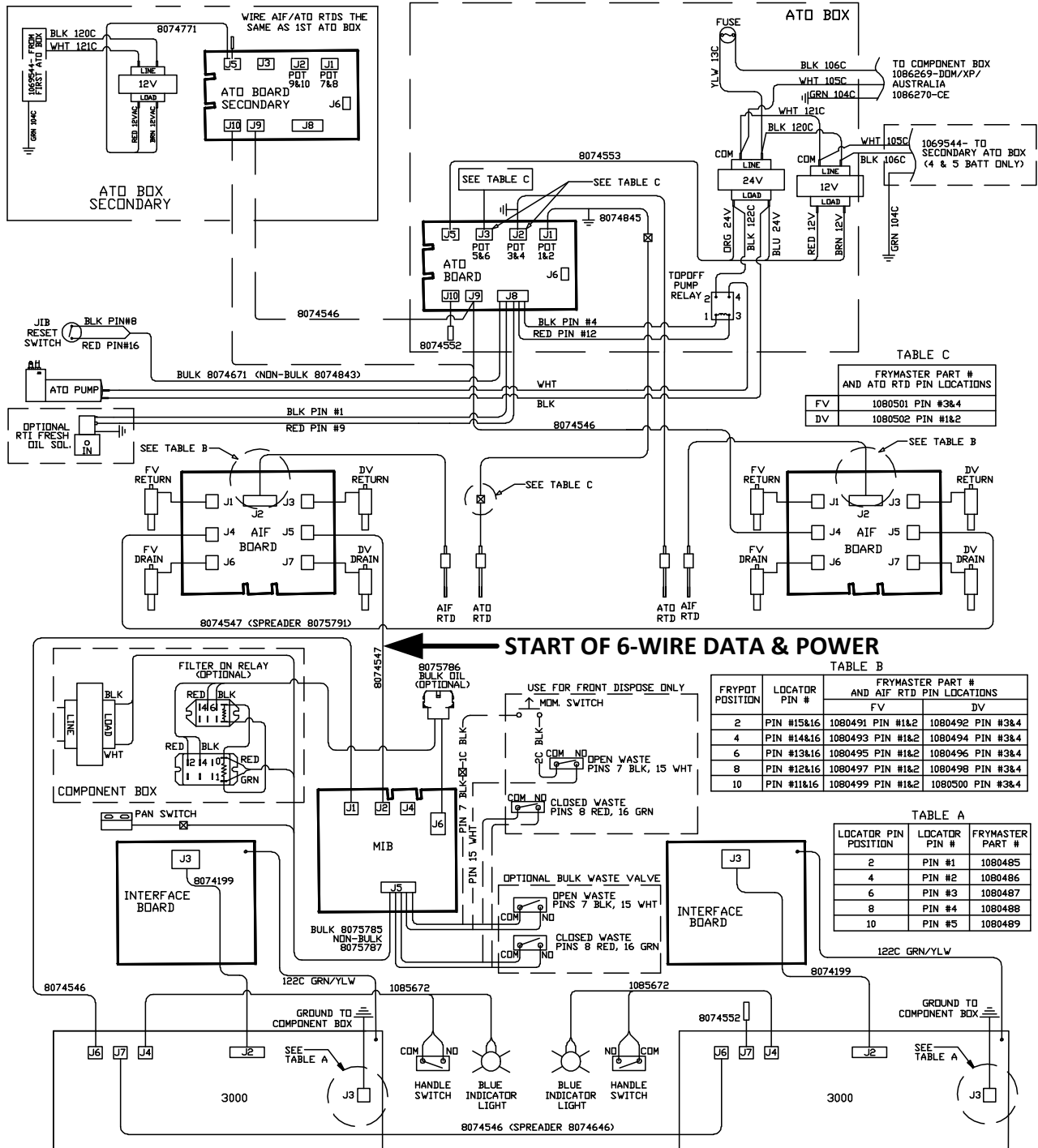

8051979F

1.8 Shortening Melting Unit Wiring Diagram

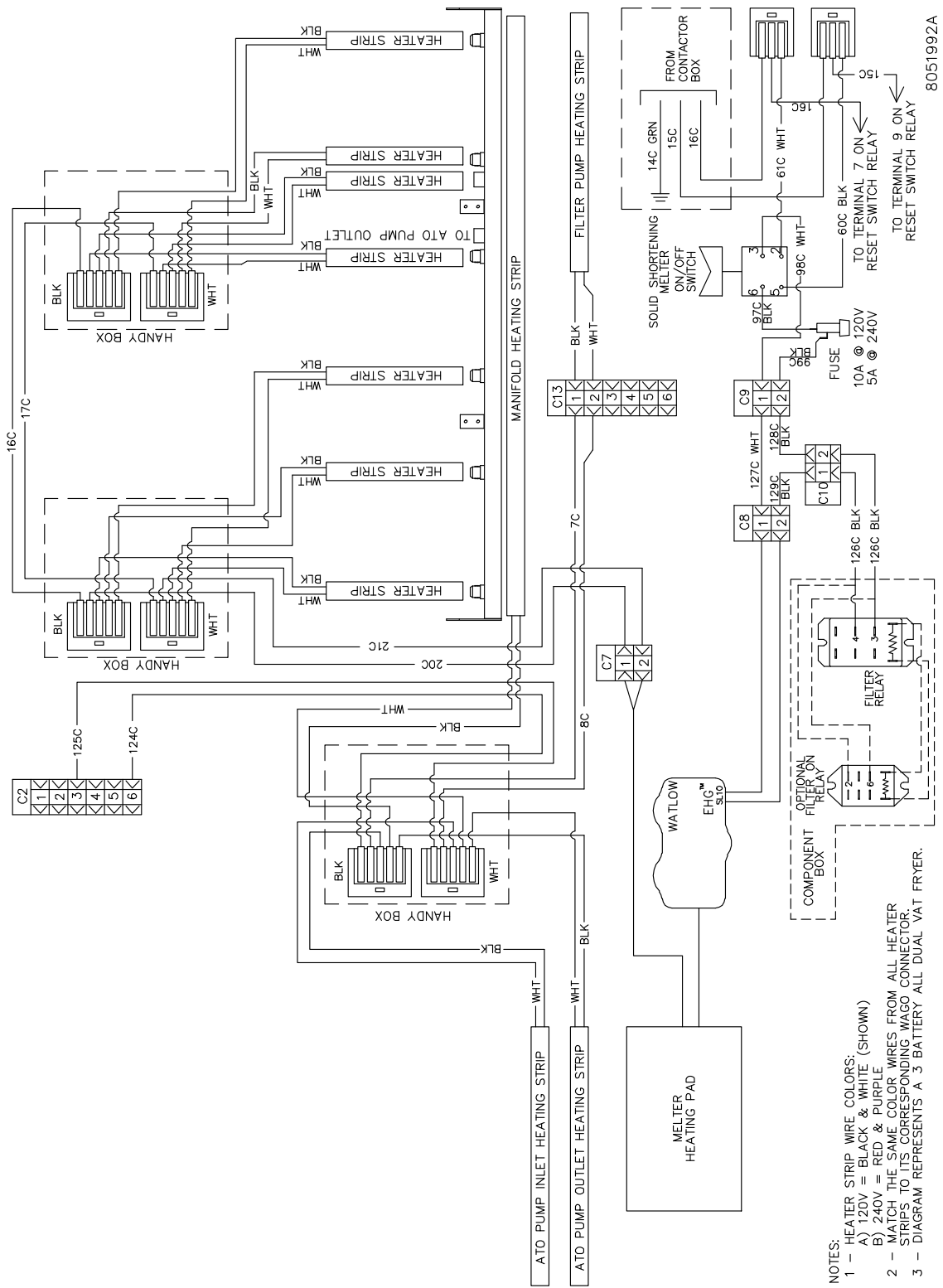

1.9 Modular Basket Lift Wiring Diagram 100-120V

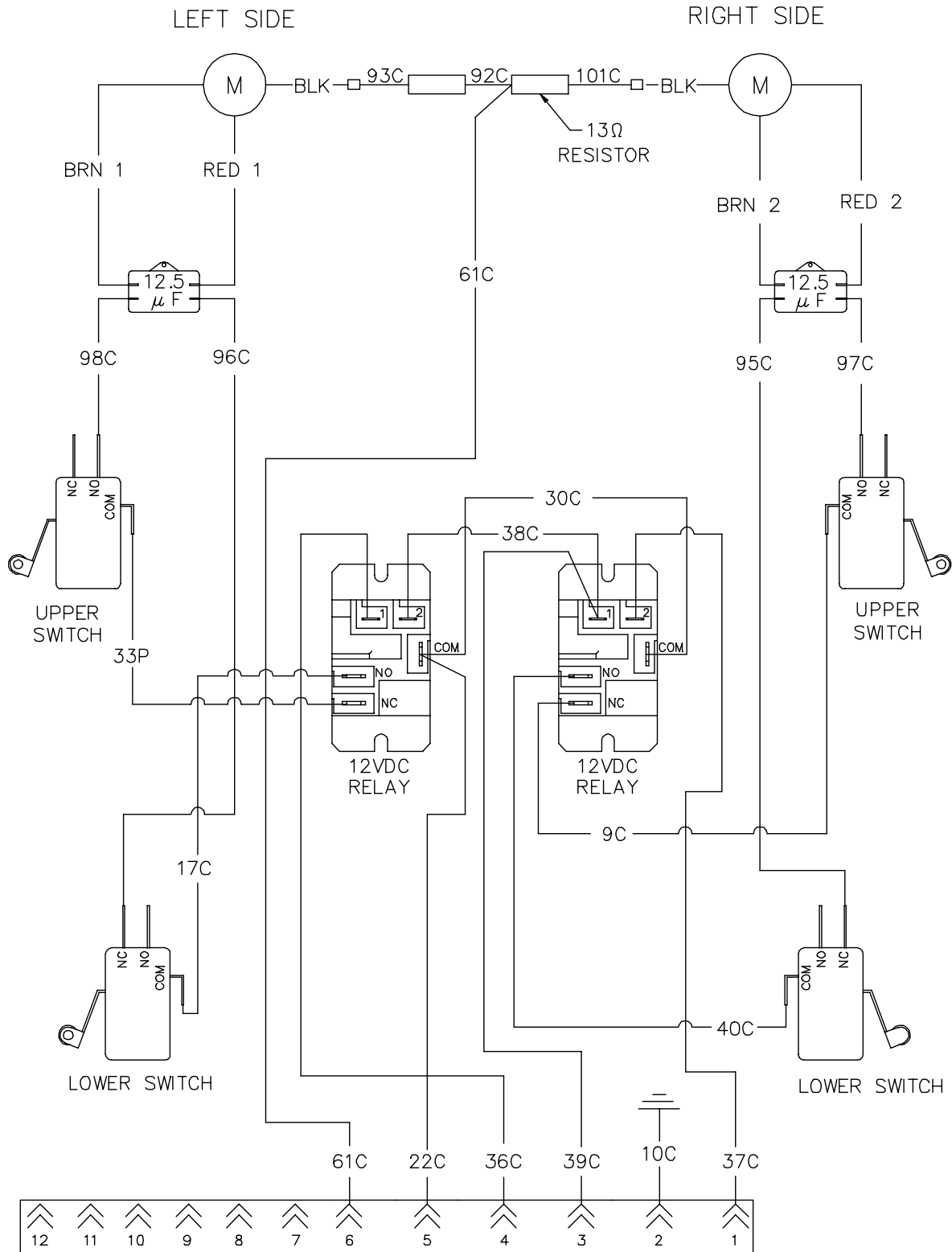

REFERENCES TO LEFT & RIGHT ARE FROM THE REAR OF THE FRYER

8050555E

1.10 Modular Basket Lift Wiring Diagram 208-250V

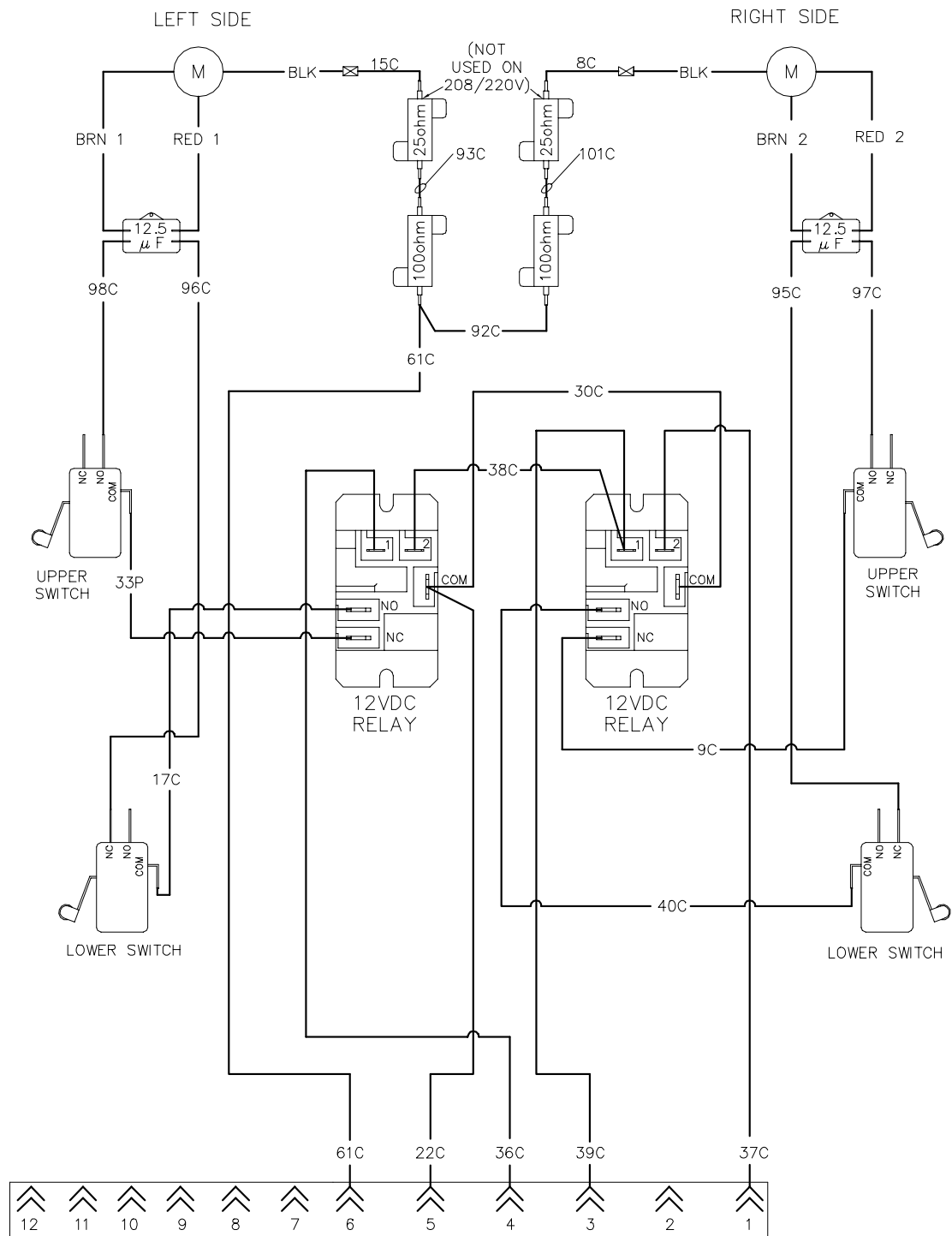

REFERENCES TO LEFT & RIGHT ARE FROM THE REAR OF THE FRYER

8050888D

1.11 Modular Basket Lift Wiring Diagram - 480V – After Feb. 2019 (Modular)

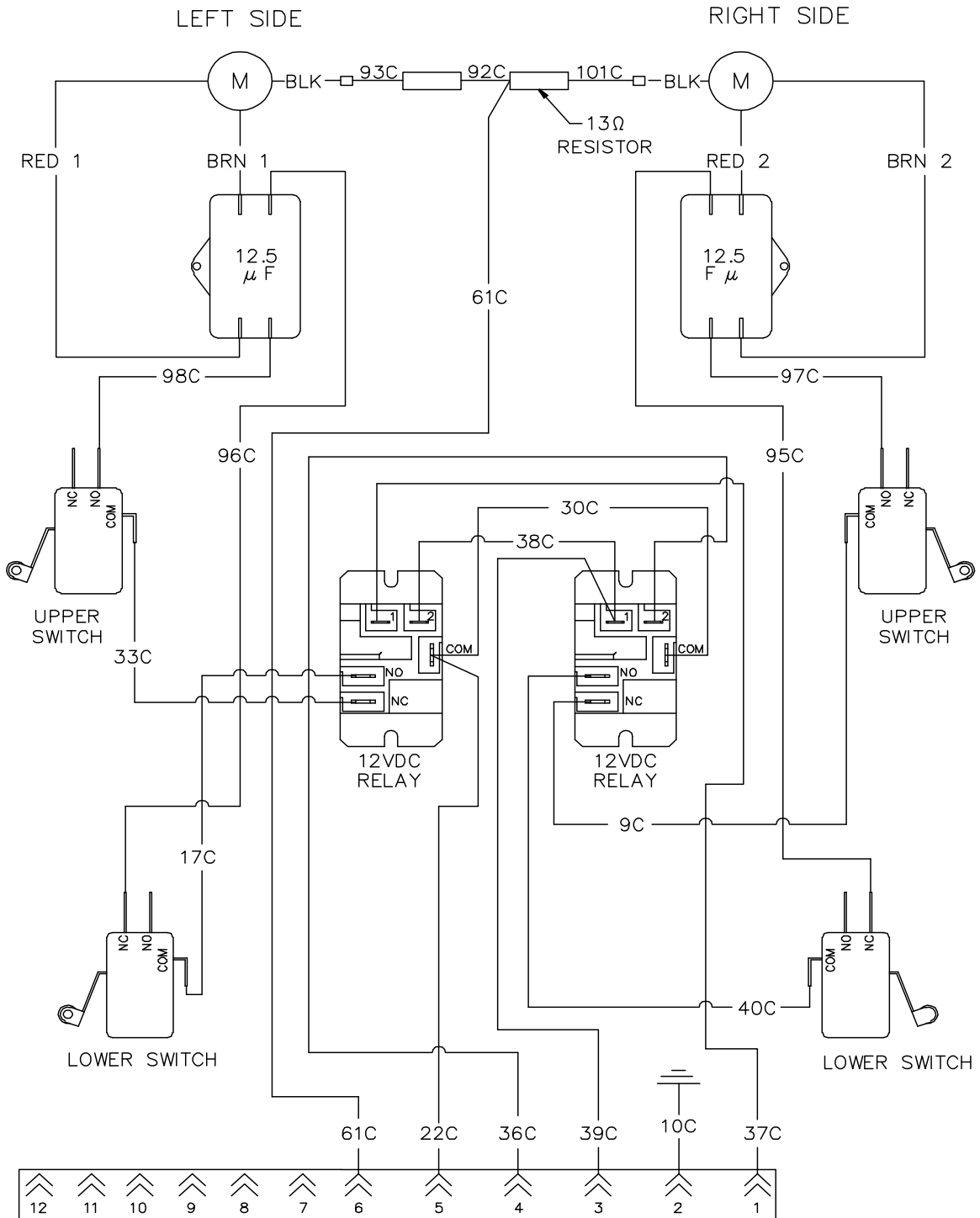

REFERENCES TO LEFT & RIGHT ARE FROM THE REAR OF THE FRYER

8051924C

1.12 Modular Basket Lift Wiring Diagram - 200V-250V – After April 2014 (Modular)

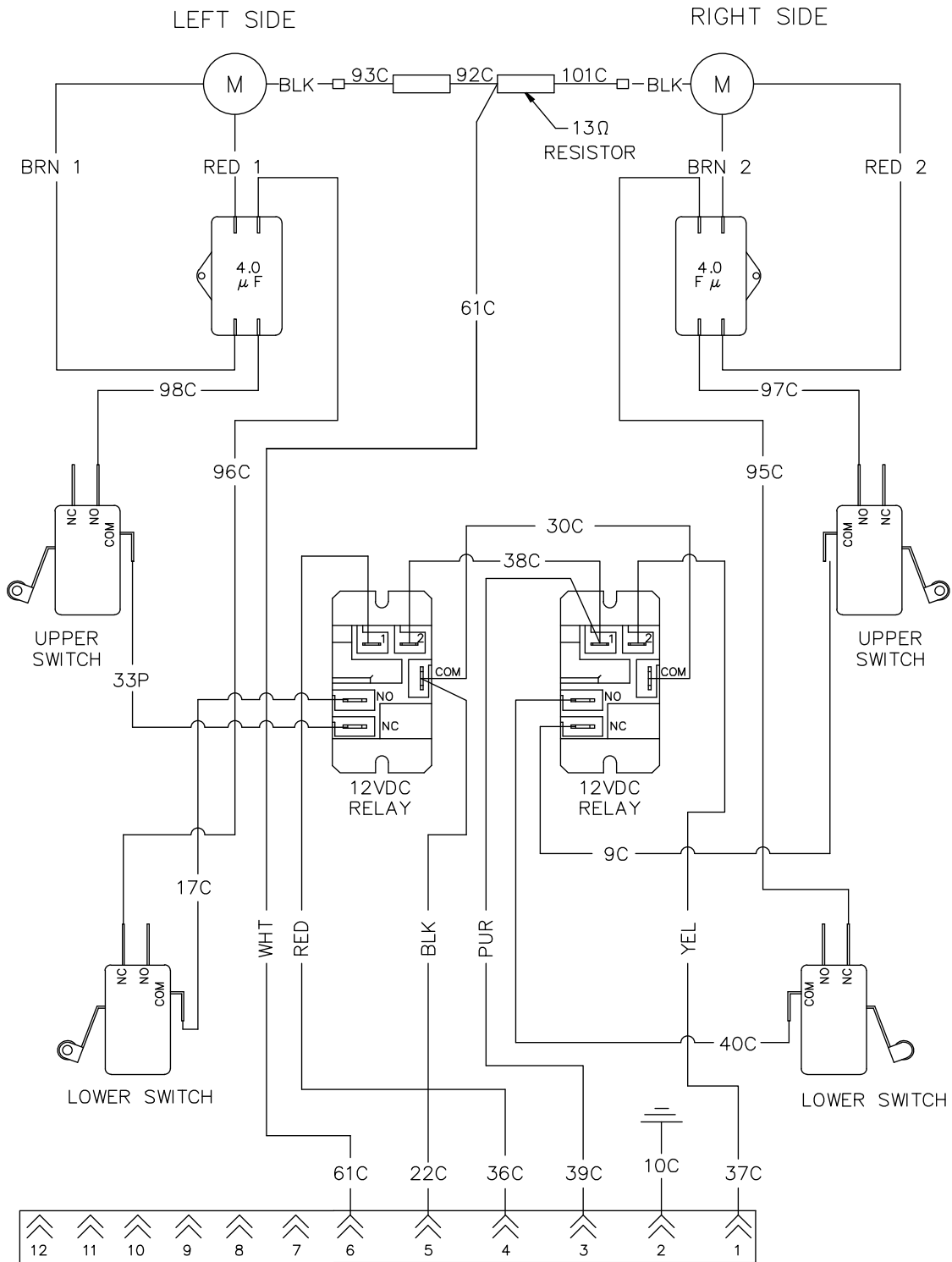

REFERENCES TO LEFT & RIGHT ARE FROM THE REAR OF THE FRYER

THIS PAGE INTENTIONALLY LEFT BLANK

Frymaster[®]

FRYMASTER
8700 LINE AVENUE, SHREVEPORT, LA 71106-6800

800-551-8633
318-865-1711
WWW.FRYMASTER.COM
EMAIL: FRYSERVICE@WELBILT.COM



Welbilt offers fully-integrated kitchen systems. Welbilt's portfolio of award-winning brands includes Cleveland™, Convotherm®, Crystal Tips®, Dean®, Delfield®, Fabristeel®, Frymaster®, Garland®, Inducs®, Koldtech®, Kolpak®, Lincoln®, McCann's™, Merco®, Merrychef®, Multiplex®, RDI®, SerVend™, SunFire®, U.S. Range™, and WMaxx™. Supported by service brands: FitKitchen®, kitchen systems; and KitchenConnect®, cloud-based open platform.

Bringing innovation to the table • welbilt.com

©2023 Frymaster LLC. except where explicitly stated otherwise. All rights reserved. Continuing product improvement may necessitate change of specifications without notice.

Part Number FRY_D_8197225 08/2023