

# Frymaster®

Your Growth Is Our Goal

## FilterQuick™ FQE30-T easyTouch® Electric Fryer

### Service Manual

This manual is updated as new information and models are released. Visit our website for the latest manual.



#### FOR YOUR SAFETY

Do Not Store or use gasoline or other flammable vapors and liquids in the vicinity of this or any other appliance.

**⚠ CAUTION**

**READ THE INSTRUCTIONS BEFORE USING THE FRYER.**



8 1 9 7 4 6 5

Part Number: FRY\_SM\_8197465 11/2023

Original Instructions



**NOTICE**

IF, DURING THE WARRANTY PERIOD, THE CUSTOMER USES A PART FOR THIS FRYMASTER DEAN EQUIPMENT OTHER THAN AN **UNMODIFIED** NEW OR RECYCLED PART PURCHASED DIRECTLY FROM FRYMASTER DEAN, OR ANY OF ITS FACTORY AUTHORIZED SERVICERS, AND/OR THE PART BEING USED IS MODIFIED FROM ITS ORIGINAL CONFIGURATION, THIS WARRANTY WILL BE VOID. FURTHER, FRYMASTER DEAN AND ITS AFFILIATES WILL NOT BE LIABLE FOR ANY CLAIMS, DAMAGES OR EXPENSES INCURRED BY THE CUSTOMER WHICH ARISE DIRECTLY OR INDIRECTLY, IN WHOLE OR IN PART, DUE TO THE INSTALLATION OF ANY MODIFIED PART AND/OR PART RECEIVED FROM AN UNAUTHORIZED SERVICER.

**NOTICE**

This appliance is intended for professional use only and is to be operated by qualified personnel only. A Frymaster Authorized Servicer (FAS) or other qualified professional should perform installation, maintenance, and repairs. Installation, maintenance, or repairs by unqualified personnel may void the manufacturer's warranty. See Chapter 1 of the IO manual for definitions of qualified personnel.

**NOTICE**

This equipment must be installed in accordance with the appropriate national and local codes of the country and/or region in which the appliance is installed. See NATIONAL CODE REQUIREMENTS in Chapter 2 of the IO manual for specifics.

**NOTICE TO U.S. CUSTOMERS**

This equipment is to be installed in compliance with the basic plumbing code of the Building Officials and Code Administrators International, Inc. (BOCA) and the Food Service Sanitation Manual of the U.S. Food and Drug Administration.

**NOTICE**

Drawings and photos used in this manual are intended to illustrate operational, cleaning and technical procedures and may not conform to onsite management operational procedures.

**NOTICE TO OWNERS OF UNITS EQUIPPED WITH CONTROLLERS**

**U.S.**

This device complies with Part 15 of the FCC rules. Operation is subject to the following two conditions: 1) This device may not cause harmful interference, and 2) This device must accept any interference received, including interference that may cause undesired operation. While this device is a verified Class A device, it has been shown to meet the Class B limits.

**CANADA**

This digital apparatus does not exceed the Class A or B limits for radio noise emissions as set out by the ICES-003 standard of the Canadian Department of Communications.

Cet appareil numérique n'émet pas de bruits radioélectriques dépassant les limites de classe A et B prescrites dans la norme NMB-003 édictée par le Ministre des Communications du Canada.

 **DANGER**

Improper installation, adjustment, maintenance or service, and unauthorized alterations or modifications can cause property damage, injury, or death. Read the installation, operating, and service instructions thoroughly before installing or servicing this equipment.

 **DANGER**

Adequate means must be provided to limit the movement of this appliance without depending on or transmitting stress to the electrical conduit. A restraint kit is provided with the fryer. If the restraint kit is missing contact your local KES.

**⚠ DANGER**

The front ledge of this appliance is not a step! Do not stand on the appliance. Serious injury can result from slips or contact with the hot oil.

**⚠ DANGER**

Do not store or use gasoline or other flammable liquids or vapors in the vicinity of this or any other appliance.

**⚠ WARNING**

Use caution and wear appropriate safety equipment to avoid contact with hot oil or surfaces that may cause severe burns or injury.

**⚠ DANGER**

Keep all items out of drains. Closing actuators may cause damage or injury.

**⚠ WARNING**

Operation, installation, and servicing of this product may expose you to chemicals/products including [Bisphenol A (BPA), glass wool or ceramic fibers, and crystalline silica], which is [are] known to the State of California to cause cancer, birth defects or other reproductive harm. For more information go to [www.P65Warnings.ca.gov](http://www.P65Warnings.ca.gov).

# Table of Contents

## Section 1: Service Procedures

1.1	FQ4000 Menu Summary Trees .....	1-1
1.1.1	FQ4000 Menu Tree BK/GM (Non-Taco Bell) .....	1-1
1.1.2	FQ4000 Information Statistics Menu Tree BK/GM (Non-Taco Bell) .....	1-2
1.1.3	FQ4000 Menu Tree Taco Bell .....	1-3
1.1.4	FQ4000 Information Statistics Menu Tree Taco Bell .....	1-4
1.1.5	FQ4000 FS Menu Tree Whataburger .....	1-5
1.1.6	FQ4000 FS Information Statistics Menu Tree Whataburger .....	1-6
1.2	FQ4000 Password Codes .....	1-7
1.3	Service Required Errors .....	1-7
1.4	Error Log Codes .....	1-7
1.5	Component Check .....	1-9
1.6	Troubleshooting and Problem Isolation .....	1-10
1.6.1	General .....	1-10
1.6.2	Accessing Fryers for Servicing .....	1-10
1.7	Heating Failure .....	1-10
1.7.1	Troubleshooting the 24VAC Circuit .....	1-11
1.7.2	Smart Interface Board (SIB) .....	1-12
1.7.3	Full/Split Vat flow through the SIB Board .....	1-13
1.7.4	Frequently Used Test Points for SIB .....	1-14
1.7.5	SIB (Smart Interface Board) Troubleshooting .....	1-14
1.7.6	SIB (Smart Interface Board) Pin Positions and Harnesses .....	1-15
1.7.7	Replacing Control Box Components (Smart Interface Board (SIB)), Transformer .....	1-16
1.8	Improper Temperature Control .....	1-16
1.8.1	Thermostats .....	1-16
1.8.2	Troubleshooting the Temperature Probe .....	1-17
1.8.3	Probe Resistance Chart .....	1-17
1.8.4	Replacing the High-Limit Thermostat .....	1-17
1.8.5	Replacing the Temperature Probe .....	1-18
1.9	Controller Malfunctions .....	1-18
1.9.1	FQ4000 Controller Troubleshooting .....	1-19
1.9.2	FQ4000 Controller Functional Troubleshooting .....	1-21
1.9.3	Replacing the Controller or the Controller Wiring Harnesses .....	1-22
1.10	Filtration Malfunctions .....	1-23
1.10.1	Built-in Filtration System Service Procedures .....	1-23
1.10.2	Filtration System Problem Resolution .....	1-23
1.10.3	Filtration Troubleshooting .....	1-24
1.10.4	FIB (Filter Interface Board) Service Procedures .....	1-24
1.10.5	Manually Draining, Refilling, Filtering or Topping off - Manual Filtration Mode .....	1-24
1.10.6	Replacing the Filter Motor or Filter Pump .....	1-26
1.11	ATO (Automatic Top-Off) and Filtration Malfunctions and Service Procedures .....	1-26
1.11.1	ATO (Automatic Top-Off Troubleshooting) .....	1-26
1.11.2	Test points on rear of FIB box .....	1-30
1.11.2.1	12-pin connector on rear FIB box .....	1-30
1.11.2.2	Connections on rear of FIB box .....	1-30
1.11.3	FIB (Filter Interface Board) LED's and Test Points .....	1-31
1.11.4	FIB (Filter Interface Board) Filtration Top-off Pin Positions and Harnesses .....	1-32
1.11.5	Replacing FIB Board, Power Supply, or SUI Communication Board .....	1-33
1.11.6	Replacing the ATO Pump or Solenoid .....	1-33
1.11.7	Replacing the ATO or VIB (AIF) Probe .....	1-33
1.12	VIB (Valve Interface Board) Service Procedures .....	1-34

1.12.1	VIB (Valve Interface Board) Troubleshooting .....	1-35
1.12.2	VIB (Valve Interface Board) Pin Positions and Harnesses.....	1-36
1.12.3	Replacing a VIB (Valve Interface Board) Board .....	1-37
1.12.4	Replacing a Rotary Actuator .....	1-37
1.13	Control Power Switch.....	1-37
1.14	Leakage.....	1-37
1.15	Loading and Updating Software Procedures.....	1-39
1.16	Replacing Fryer Components.....	1-41
1.16.1	Replacing the Contactor Box Components .....	1-41
1.16.2	Replacing a Heating Element .....	1-41
1.16.3	Replacing a Frypot.....	1-45
1.17	Wiring Diagrams.....	1-46
Appendix A Bulk Service Issues .....		A-1

# FQE30-T FILTERQUICK™ ELECTRIC FRYERS

## CHAPTER 1: SERVICE PROCEDURES

### 1.1 FQ4000 Menu Summary Trees

#### 1.1.1 FQ4000 Menu Tree General Market/Burger King (Non-Taco Bell)

Reflected below are the major programming sections in the FQ4000 and the order in which the headings will be found in the controller.

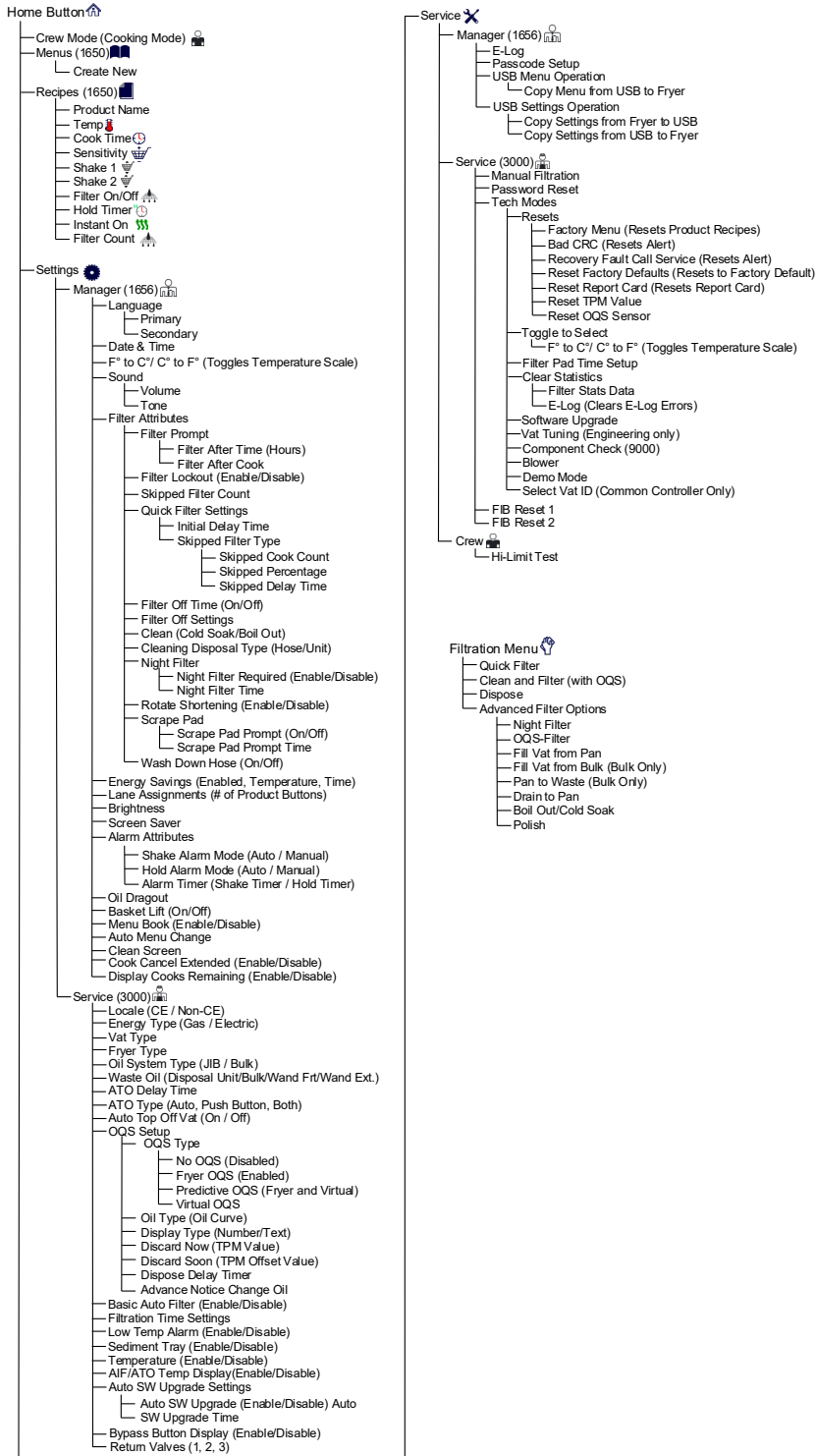

## 1.1.2 FQ4000 Information Statistics Menu Tree General Market/Burger King

Reflected below are the information statistics in the FQ4000 and the order in which the headings will be found in the controller.

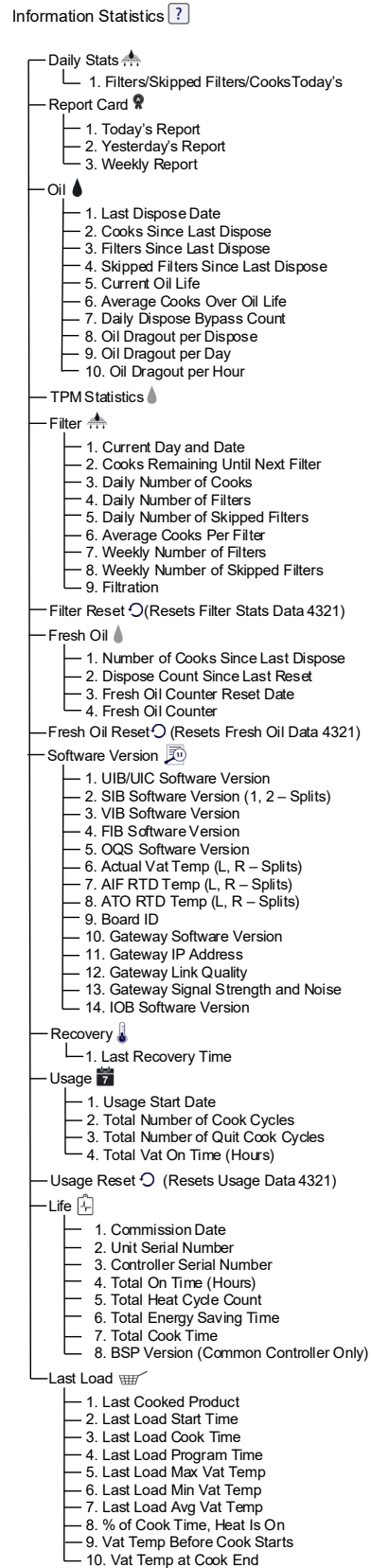

### 1.1.3 FQ4000 Menu Tree Taco Bell

Reflected below are the major programming sections in the FQ4000 and the order in which the headings will be found in the controller.

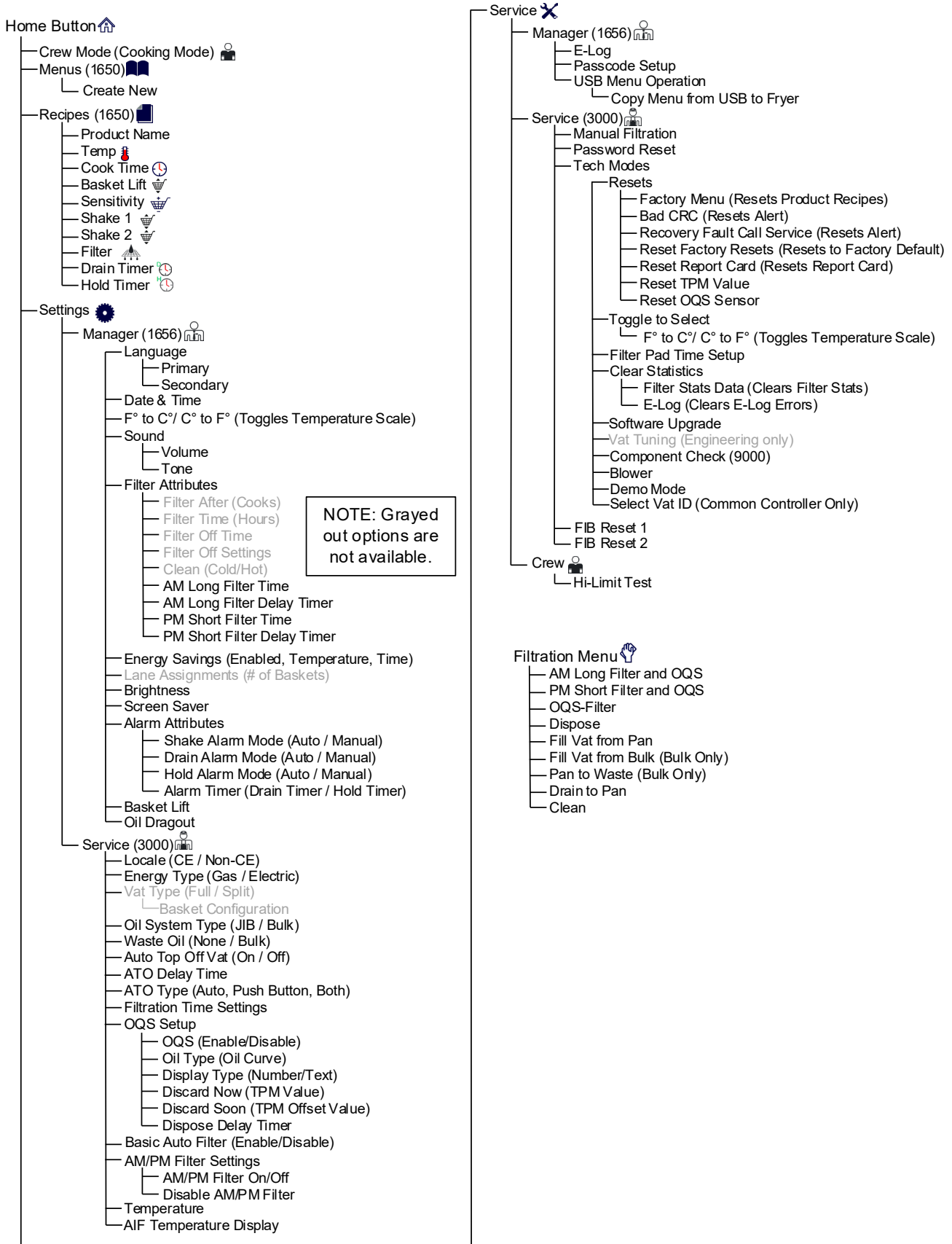

## 1.1.4 FQ4000 Information Statistics Menu Tree Taco Bell

Reflected below are the information statistics in the FQ4000 and the order in which the headings will be found in the controller.

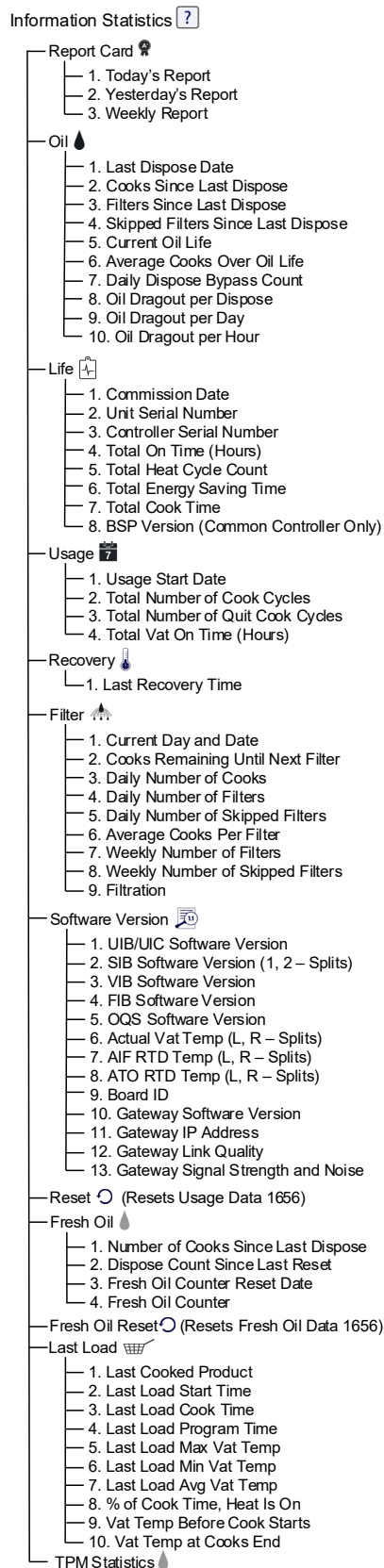













## 1.1.5 FQ4000 FS Menu Tree Whataburger

Reflected below are the major programming sections in the FQ4000 and the order in which the headings will be found in the controller.



### Filtration Menu

- Quick Filter
- Clean and Filter (with OQS – OQS Only)
- OQS Filter (OQS Only)
- Dispose Oil
- Drain Oil
- Fill Vat from Drain Pan
- Fill Vat from Bulk (Bulk Only)
- Oil Pan to Waste (Bulk Only)
- Boil Out

### Home Button

- Crew Mode (Cooking Mode) 
- Menus (1650) 
  - Create New
- Recipes (1650) 
  - Product Name
  - Temp 
  - Cook Time 
  - Load Size 
  - Quality Timer 
  - Shake 1 
  - Shake 2 
  - Filter 
- Settings 
  - Manager (1656) 
    - Language
      - Primary
      - Secondary
    - Date & Time (Set Time, Set Date, DST Setup)
    - F° to C°/ C° to F° (Toggles Temperature Scale)
    - Sound
      - Volume
      - Tone
    - Filter Attributes
      - Filter After (Cooks)
      - Filter Time (Hours)
      - Filter Lockout
      - Filtration Lockout Time
    - Energy Savings (Enabled, Temperature, Time)
    - Lane Assignments (# of Baskets)
    - Brightness
    - Screen Saver
  - Service (3000) 
    - Locale (CE / Non-CE/Japan)
    - Energy Type (Gas / Electric)
    - Vat Type (Full / Split)
      - Basket Configuration
    - Oil System Type (JIB / Bulk)
    - Waste Oil (None / Bulk/Front Dispose)
    - Auto Top Off Vat (On/Off/(User Prompted Top Off (Jpn only)))
    - User Prompted Top Off Timer (Jpn only)
    - ATO Delay Time
    - Filtration Time Settings
    - Filtration Type (Solid / Liquid) (Gas only)
    - OQS Setup
      - OQS (Enable/Disable)
      - Oil Type (Oil Curve)
      - Display Type (Number/Text)
      - Discard Now (TPM Value)
      - Discard Soon (TPM Offset Value)
      - Dispose Delay Timer
    - Temperature Display (Enable,Disable)
    - AIF/ATO Temp Display (Enable,Disable)

### Service

- Manager (1656) 
  - E-Log
  - Passcode Setup
  - USB Menu Operation
    - Copy Menu from USB to Fryer
    - Copy Menu from Fryer to USB
- Service (3000) 
  - Manual Filtration
  - Password Reset
  - Tech Modes
    - Resets
      - Factory Menu (Resets Product Recipes)
      - Bad CRC (Resets Alert)
      - Recovery Fault Call Service (Resets Alert)
      - Reset Factory Default (Resets to Factory Default)
      - Reset OQS Sensor
        - OQS Replacement Prompt (Enable/Disable)
        - Reset OQS Sensor (Reset OQS after Replacement)
      - Reset TPM Value (Resets TPM Value to 1)
    - Toggle to Select
      - F° to C°/ C° to F° (Toggles Temperature Scale)
    - Filter Pad Time Setup
    - Clear Statistics
      - Filter Stats Data (Clears Filter Stats)
      - E-Log (Clears E-Log Errors)
    - Software Upgrade
    - Vat Tuning (Engineering only)
    - Component Check (9000)
    - Blower
    - Demo Mode
    - Select Vat ID (Common Controller Only)
  - FIB Reset 1
  - FIB Reset 2
- Crew 
  - Hi-Limit Test

## 1.1.6 FQ4000 FS Information Statistics Menu Tree Whataburger

Reflected below are the information statistics in the FQ4000 and the order in which the headings will be found in the controller.

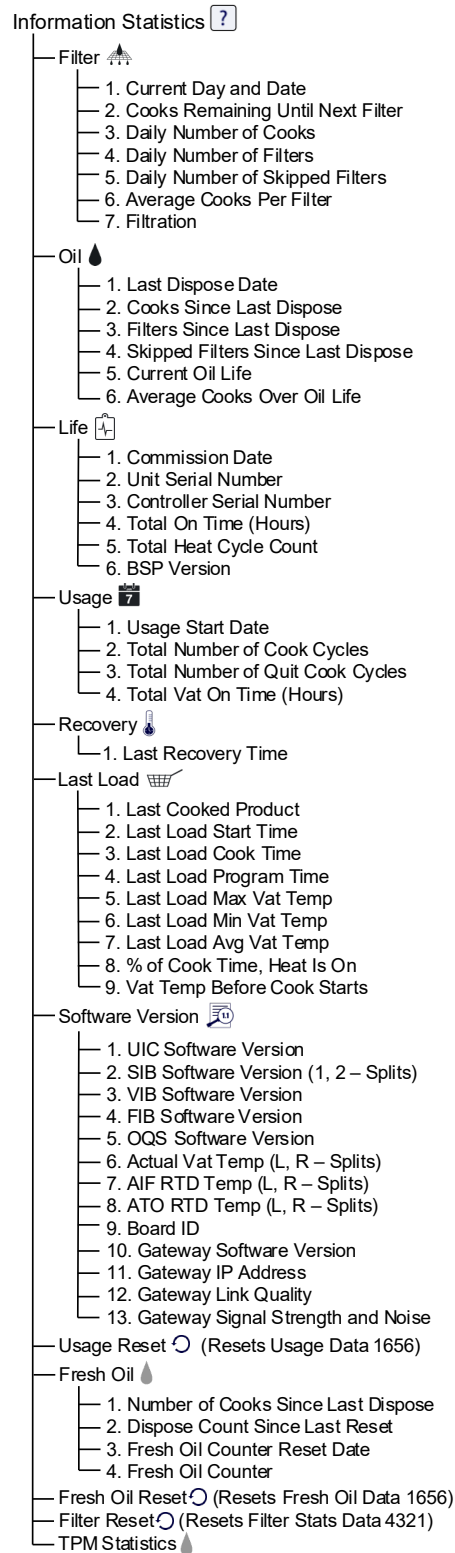

## 1.2 FQ4000 Password Codes

Press the HOME button to enter MENUS, RECIPES, SETTINGS or SERVICE menus.

- **1650 – MENUS, RECIPES,**
- **1656 – SETTINGS (MANAGER), SERVICE (MANAGER)**
- **3000 – SETTINGS (SERVICE), SERVICE (SERVICE) Enter Tech Mode**
- **9000 – Component Check [SETTINGS (SERVICE), SERVICE (SERVICE) Enter Tech Mode]**

The following code is entered when prompted to do so.

- **1111 – Reset SERVICE REQUIRED Message** – Enter when the issue is fixed and prompted to enter code.

## 1.3 Service Required Errors

A SERVICE REQUIRED error with a description of the error displays on the controller. After YES is pressed the alarm is silenced. The controller displays an error message from the list below three times with the location of the error. Then the controller displays SYSTEM ERROR FIXED? YES/NO. If yes is chosen, enter code 1111. If NO is chosen, the system returns to cook mode if possible for 15 minutes, then redisplay error until issue is fixed.

## 1.4 Error Log Codes

To access the error log, press the home button. Press the service button. Press the manager button. Enter 1656 and press the check button. Press the E-log button. The ten most recent errors are listed from top to bottom, with the top error being the most recent error. A “G” indicates a global error such as a filtration error. Side specific errors in split vats are indicated by L for left or R for right. Pressing the left down arrow allows scrolling through the errors. If no errors are present the screen will be blank.

Code	ERROR MESSAGE	EXPLANATION
<b>E13</b>	TEMPERATURE PROBE FAILURE	TEMP Probe reading out of range
<b>E16</b>	HIGH LIMIT 1 EXCEEDED	High limit temperature is past more than 410°F (210°C), or in CE countries, 395°F (202°C)
<b>E17</b>	HIGH LIMIT 2 EXCEEDED	High limit switch has opened.
<b>E18</b>	HIGH LIMIT PROBLEM DISCONNECT POWER	Vat temperature exceeds 460°F (238°C) and the high limit has failed to open. Immediately disconnect power to the fryer and call service.
<b>E19</b>	HEATING FAILURE – XXX F or XXX C	Heating Control latch circuit failed. Heat Contactor failed to latch.
<b>E25</b>	HEATING FAILURE - BLOWER	The air pressure switch(s) failed to close.
<b>E27</b>	HEATING FAILURE - PRESSURE SWITCH - CALL SERVICE	The air pressure switch has failed closed.
<b>E28</b>	HEATING FAILURE – XXX F or XXX C	The fryer has failed to ignite and has locked out the ignition module.
<b>E29</b>	TOP OFF PROBE FAILURE - CALL SERVICE	ATO RTD reading out of range
<b>E32</b>	DRAIN VALVE NOT OPEN - FILTRATION AND TOP OFF DISABLED - CALL SERVICE	Drain valve was trying to open and confirmation is missing
<b>E33</b>	DRAIN VALVE NOT CLOSED - FILTRATION AND TOP OFF DISABLED - CALL SERVICE	Drain valve was trying to close and confirmation is missing
<b>E34</b>	RETURN VALVE NOT OPEN - FILTRATION AND TOP OFF DISABLED - CALL SERVICE	Return valve was trying to open and confirmation is missing
<b>E35</b>	RETURN VALVE NOT CLOSED - FILTRATION AND TOP OFF DISABLED - CALL SERVICE	Return valve was trying to close and confirmation is missing
<b>E36</b>	VALVE INTERFACE BOARD FAILURE - FILTRATION AND TOP OFF DISABLED - CALL SERVICE	Valve Interface Board connections lost or board failure.
<b>E37</b>	AUTOMATIC INTERMITTENT FILTRATION PROBE FAILURE - FILTRATION DISABLED - CALL SERVICE	AIF (VIB Probe) RTD reading out of range.
<b>E39</b>	CHANGE FILTER PAD	25-hour timer has expired or dirty filter logic has activated.
<b>E41</b>	OIL IN PAN ERROR	The system detects that oil may be present in the filter pan.
<b>E42</b>	CLOGGED DRAIN (Gas)	Vat did not empty during filtration
<b>E43</b>	OIL SENSOR FAILURE - CALL SERVICE	Oil level sensor may have failed.

Code	ERROR MESSAGE	EXPLANATION
E44	RECOVERY FAULT	Recovery time exceeded maximum time limit.
E45	RECOVERY FAULT - CALL SERVICE	Recovery time exceeded maximum time limit for two or more cycles.
E46	SYSTEM INTERFACE BOARD 1 MISSING - CALL SERVICE	SIB board 1 connection lost or board failure.
E51	DUPLICATE BOARD ID - CALL SERVICE	Two or more controllers have the same location ID.
E52	USER INTERFACE CONTROLLER ERROR - CALL SERVICE	The controller has an unknown error.
E53	CAN BUS ERROR - CALL SERVICE	Communications are lost between boards.
E55	SYSTEM INTERFACE BOARD 2 MISSING - CALL SERVICE	SIB board 2 connection lost or board failure.
E62	SLOW HEATING FAILURE XXXF OR XXXC - CHECK ENERGY SOURCE - CALL SERVICE	The vat is not heating properly.
E63	RATE OF RISE	Rate of rise error occurred during a recovery test.
E64	FILTRATION INTERFACE BOARD FAILURE - FILTRATION AND TOP OFF DISABLED - CALL SERVICE	Filtration Interface Board connections lost or board failure.
E65	CLEAN OIB SENSOR - XXX F OR XXX C - CALL SERVICE or CLEAN FLOAT SWITCH	Gas -The oil is back sensor or float switch does not detect oil. Clean optional oil sensor or float switch
E66	DRAIN VALVE OPEN - XXXF OR XXXC	Drain valve is opened during cooking.
E67	SYSTEM INTERFACE BOARD NOT CONFIGURED - CALL SERVICE	Controller is turned on when the SIB board is not configured.
E68	OIB FUSE TRIPPED - CALL SERVICE	The VIB board OIB fuse has tripped and didn't reset.
E69	RECIPES NOT AVAILABLE	The controller has not been programmed with product recipes. Replace controller with factory programmed controller.
E70	OQS TEMP HIGH	Oil temperature is too high for a valid OQS reading. Filter at a temperature between 300°F (149°C) and 375°F (191°C).
E71	OQS TEMP LOW	Oil temperature is too low for a valid OQS reading. Filter at a temperature between 300°F (149°C) and 375°F (191°C).
E72	TPM RANGE LOW	The TPM is too low for a valid OQS reading. This may also be seen with fresh new oil. The incorrect oil type may be selected in the setup menu. The sensor may not be calibrated for the oil type. See oil type chart in instruction document 8197316. If issue continues contact an FAS.
E73	TPM RANGE HIGH	The TPM reading is too high for a valid OQS reading. Dispose the oil.
E74	OQS ERROR	The OQS has an internal error. If issue continues contact an FAS.
E75	OQS AIR ERROR	The OQS is detecting air in the oil. Check the O-rings and check/tighten prescreen filter to ensure no air is entering the OQS sensor. If issue continues contact an FAS.
E76	OQS ERROR	The OQS sensor has a communication error. Check connections to the OQS sensor. Power cycle the entire fryer battery. If issue continues contact an FAS.
E81	SAFE MODE FAILURE ERROR	The system has detected the fryer is not heating properly due to low oil conditions. Turn the fryer off. Ensure the fryer has oil to the bottom fill line or higher. If not, add oil to the bottom fill line. Turn fryer back on. <b>If prompted, enter code 4357.</b>
E82	LOW OIL DETECTED	This is only visible in the cloud. It's not visible on the UI. The vat doesn't have enough oil to cover the AIF/ATO probes. Fill the vat with oil.
E83	TOP OFF EMPTY	This is only visible in the cloud. It's not visible on the UI. The JIB is out of oil. Replace the JIB and top off the vat.
E85	LEFT RETURN VALVE or LEFT VALVE NOT OPEN VALVE NOT OPE - FILTRATION AND TOP OFF DISABLED - CALL SERVICE	Left return valve was trying to open, and confirmation is missing
E86	LEFT RETURN VALVE or LEFT VALVE NOT CLOSED - FILTRATION AND TOP OFF DISABLED - CALL SERVICE	Left Return valve was trying to close, and confirmation is missing
E87	RIGHT RETURN VALVE or CENTRAL VALVE NOT OPEN - FILTRATION AND TOP OFF DISABLED - CALL SERVICE	Right return valve or Central Valve was trying to open, and confirmation is missing

Code	ERROR MESSAGE	EXPLANATION
E88	RIGHT RETURN VALVE or CENTRAL VALVE NOT CLOSED - FILTRATION AND TOP OFF DISABLED - CALL SERVICE	Right return valve or Central Valve was trying to close, and confirmation is missing

## 1.5 Component Check

The FQ4000 controller has a function to check the major components and their status.

With the controller soft powered OFF, press the HOME button. Select Service, Service, Enter 9000, Select Tech Modes, and scroll down and select Component Check.

The component name is above each button. The status of the component is below the function. Pressing the button will change the status of the function to what is stated on the button. If the button is shaded that function is not available unless that function is enabled (such as bulk). The JIB reset button and Waste Tank full only displays the status of the switch.

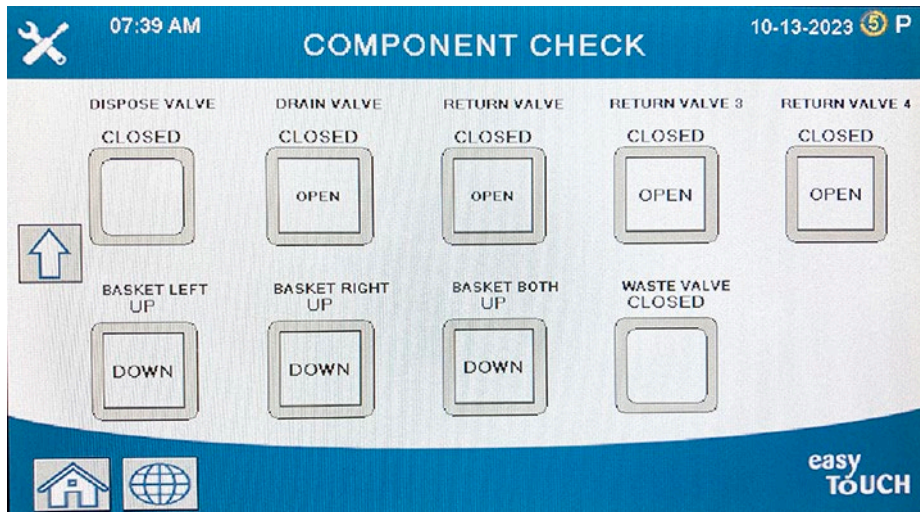
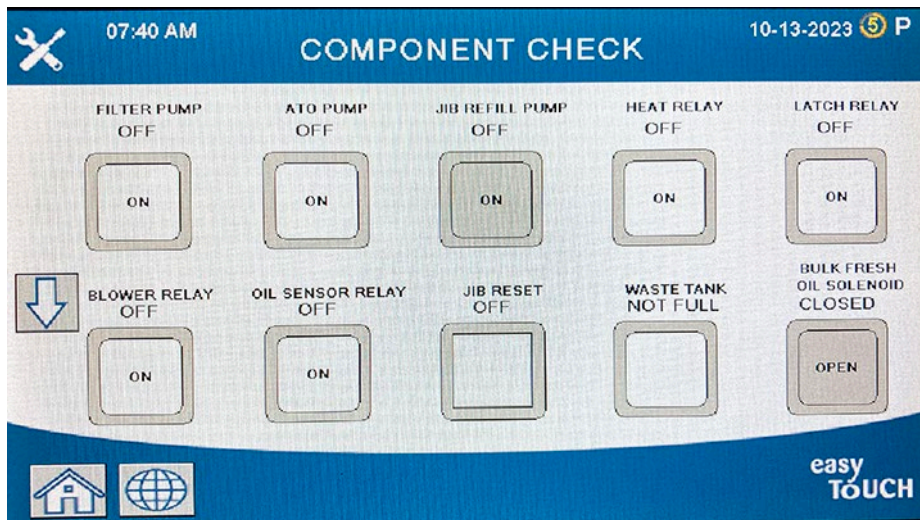

Pressing the home button to exit the function will display driving valves to ensure all valves return to home state. Once completed the controller will display FILL VAT FROM DRAIN PAN? YES NO. Press YES to ensure that any oil in the filter pan is returned to the vat.

## 1.6 Troubleshooting and Problem Isolation

Because it is not feasible to attempt to include in this manual every conceivable problem or trouble condition that might be encountered, this section is intended to provide technicians with a general knowledge of the broad problem categories associated with this equipment, and the probable causes of each. With this knowledge, the technician should be able to isolate and correct any problem encountered.

Problems you are likely to encounter can be grouped into six categories:

1. Heating failure
2. Improper temperature control
3. Controller or board malfunctions
4. Filtration malfunctions
5. Auto Top Off malfunctions
6. Bulk oil system malfunctions
7. Leakage

The probable causes of each category are discussed in the following sections. A series of Troubleshooting Guides is also included in each section to assist in solving some of the more common problems. The troubleshooting guides on the following pages are intended to assist service technicians in quickly isolating the probable causes of equipment malfunctions by following a logical, systematic process. An additional set of operators troubleshooting guides are contained in Chapter 7 of the FQE30-T Series Installation and Operation Manual. It is suggested that service technicians thoroughly familiarize themselves with both sets.

### 1.6.1 General

Before performing any maintenance on your Frymaster fryer, disconnect the fryer from the electrical power supply.

When electrical wires are disconnected, it is recommended that they be marked in such a way as to facilitate re-assembly.

### 1.6.2 Accessing Fryers for Servicing



**Moving a fryer filled with oil may cause spilling or splattering of the hot liquid. Follow the draining instructions in section 5.3.6 in Chapter 5 of the FQE30-T Installation and Operation Manual before attempting to relocate a fryer for servicing.**

1. Unplug the power cords.
2. Remove any attached restraining devices and relocate the fryer for service accessibility.
3. After servicing is complete, reattach restraining devices, and plug in the electrical cords.

## 1.7 Heating Failure

Heating failure occurs when the heating contactor fails to stay engaged and locks out. When this happens, the module sends 24 VAC through the interface board alarm circuit to the controller.

FQ4000 controllers display **"HEATING FAILURE"**.

The three primary reasons for heating failure, listed in order of probability, are problems related to:

1. Electrical power supplies
2. Electronic circuits
3. Contactor issues

### PROBLEMS RELATED TO THE ELECTRICAL POWER SUPPLIES

The main indicators of this are that the fryer does not operate and there are no indicator lights illuminated on the fryer experiencing heating failure. Verify that the fryer is plugged in with connector twisted and locked and the circuit breaker for the fryer electrical supply is not tripped.

## PROBLEMS RELATED TO THE ELECTRONIC CIRCUITS

If electrical power is being supplied to the fryer, the next most probable cause of heating failure is a problem in the 24 VAC circuit. Verify that the transformer is operating correctly. Refer to Section 1.7.4.

### TROUBLESHOOTING THE 24 VAC CIRCUIT.

Some typical causes of heating failure in this category include a defective transformer, a defective relay, a defective contactor, defective smart interface board (SIB) or defective elements.

#### 1.7.1 Troubleshooting the 24 VAC Circuit

Prior to checking for problems associated with the 24 VAC circuit, ensure that the unit is connected to a power supply, and the controller is on and is calling for heat (heat indicator appears and displays PRE-HEAT).

**NOTE:** All voltage measurements must be made within **4 seconds** of the unit calling for heat. If unit has an error the controller may lock out and controller must be turned off, then on to reset.

**DO NOT CHECK WITH HARNESES UNPLUGGED AS SHORTING THE PINS MAY OCCUR WHICH WILL DAMAGE THE BOARD.**

The following processes will assist you in troubleshooting the 24 VAC circuit and ruling it out as a probable cause:

- **24 VAC is not present on the interface board J1 pin 1.**
  1. If LED's 2, 4 and 6 *are not* continually lit, the probable causes are a loose or blown fuse, failed 24 VAC transformer, or failed wiring between the transformer and interface board.
- **24 VAC is present on interface board J1 pin 1.**
  1. If 24 VAC *is not* present at the latch contactor, the probable causes are an open high-limit thermostat, a failed latch relay or a failed wire between the interface board and the latch contactor or a failed interface board.
    - a. Check continuity of high-limit thermostat. If it is zero, problem is in wiring.
  2. If 24 VAC *is not* present at the heat contactor, the probable causes are a failed heat relay, latch contactor a failed latch contactor, or a failed wire between the interface board and the heat contactor, a failed optional tilt switch or a failed interface board.
  3. If LED 3 is *not* continually lit with the controller in the ON position, the probable cause is a defective latch relay.
  4. If LED 1 is *not* continually lit with the controller in the ON position and calling for heat, the probable cause is a defective heat relay.



### 1.7.3 Full/Split Vat flow through the SIB (Smart Interface Board)

# ELECTRIC SYSTEM

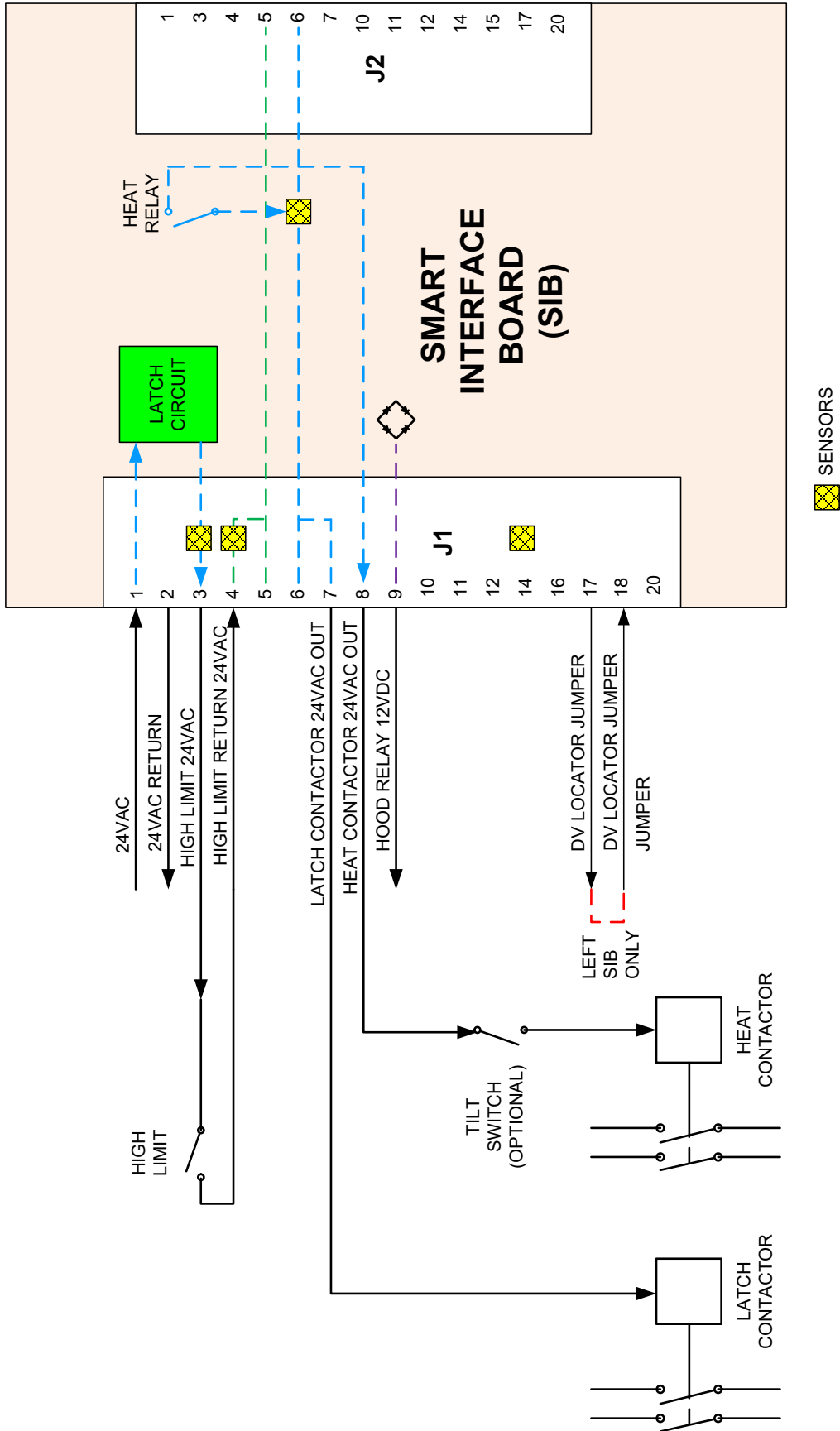

### 1.7.4 Frequently Used Test Points for SIB (Smart Interface Board)

**NOTE: DO NOT CHECK WITH HARNESES UNPLUGGED AS SHORTING THE PINS MAY OCCUR WHICH WILL DAMAGE THE BOARD.**

FREQUENTLY USED TEST POINTS FOR INTERFACE BOARD 1085979			
Test	Meter Setting	Pins	Results
24VAC Power to SIB	50VAC Scale	1 on J1 and GROUND	22-28
12VDC Power to Controller	50VDC Scale	7 and 8 on J6	12-18
24VAC Power to Latch Contactor	50VAC Scale	7 on J1 and GROUND	22-28
24VAC Power to Heat Contactor	50VAC Scale	8 on J1 and GROUND	22-28
Latch Contactor Coil	R x 1 OHM	7 on J1 and GROUND	3-10 OHMS
Heat Contactor Coil	R x 1 OHM	8 on J1 and GROUND	11-15 OHMS
24VAC Power to High-Limit	50VAC Scale	3 on J1 and GROUND	22-28
Probe Resistance	R x 1000 OHMS	Disconnect and test across probe leads	**
Probe Isolation	R x 1000 OHMS	2 on Probe Connector and GROUND	***
High-Limit Continuity	R x 1 OHM	3 on J1 and 4 on J1	0
** See Probe Resistance Chart in section 1.8.3.			
*** 5 mega-Ohms or greater.			

### 1.7.5 SIB (Smart Interface Board) Troubleshooting

Problem	Probable Causes	Corrective Action
<b>No power to SIB board</b>	<ul style="list-style-type: none"> <li>A. J1 connection unplugged.</li> <li>B. Fuse blown.</li> <li>C. Transformer malfunction.</li> <li>D. Harness between VIB board and SIB board is shorted.</li> </ul>	<ul style="list-style-type: none"> <li>A. Check to ensure J1 on front of SIB board is fully locked into connector.</li> <li>B. Ensure fuse(s) located at the bottom of the control box are not blown and cap is securely tightened.</li> <li>C. Check that proper voltage is present at transformer. See table in section 1.7.4.</li> <li>D. Ensure that the harness wires are not shorted.</li> </ul>
<b>SIB BOARD 1 MISSING displayed on the controller.</b>	<ul style="list-style-type: none"> <li>A. Loose wire connection.</li> </ul>	<ul style="list-style-type: none"> <li>A. Ensure the connector is securely attached to plug J6 on the SIB board.</li> </ul>
<b>SIB BOARD 2 MISSING displayed on the controller.</b>	<ul style="list-style-type: none"> <li>A. Loose wire connection.</li> </ul>	<ul style="list-style-type: none"> <li>A. Ensure all wiring harnesses are securely connected between J9 and J10 between SIB boards.</li> </ul>
<b>SIB NOT CONFIGURED displayed on the controller.</b>	<ul style="list-style-type: none"> <li>A. SIB board not configured</li> </ul>	<ul style="list-style-type: none"> <li>A. Replace the SIB board.</li> </ul>

## 1.7.6 SIB (Smart Interface Board) Pin Positions and Harnesses

**NOTE: DO NOT CHECK WITH HARNESES UNPLUGGED (except ATO and Temp Probes) AS SHORTING THE PINS MAY OCCUR WHICH WILL DAMAGE THE BOARD.**

Connector	From/To	Harness #	Pin #	Function	Voltage	Wire Color
J1	From Transformer	8075951 Full or Right of Split 8075952 Left Split	1	24VAC Input	24VAC	Orange
			2	Ground -		Blue
	To High Limit		3	24VAC Out	24VAC	Orange
	From High Limit		4	24VAC Input	24VAC	Blue
	To Latch Contactor		7	24VAC Out	24VAC	Orange
	To Heat Contactor		8	24VAC Out	24VAC	Orange
	To Hood Relay		9	12VDC Out	12VDC	Yellow
			10			Yellow
			11			Brown
			14			Blue
			16			Blue
			17	Ground -		Black
	18	5VDC Out	5VDC	Black		
			20			Orange
J2	Not Used					
J3	ATO Probe	8263286	1	Ground		Yellow
			2	RTD	3.3VDC	Red
			3			
J6	Controller		1	C-BUS +	5VDC	
			2	C-BUS -	5VDC	
			3	5VDC	5VDC	
			4	RS485 -	5VDC	
			5	RS485 +	5VDC	
			6	Signal Ground		
			7	12VDC	12VDC	
			8	Signal Ground		
J7	C-Bus Harness	8075549 or 8075551	1	5VDC+	+5VDC	
			2	CAN High		
			3	CAN Low		
			4	Ground		
J8	C-Bus Harness or Network Resistor (pins 2 & 3)	8075549 or 8075551 or (8075632 Resistor)	1	5VDC+	+5VDC	
			2	CAN High		
			3	CAN Low		
			4	Ground		
J9	P-Bus Power Communication from SIB to VIB or between SIB's RJ11	8075553	1	Ground		
			2	P-BUS power	+5VDC	
			3	Modbus RS485 B		
			4	Modbus RS485 A		
			5	Signal ground		
			6	P-BUS power	+12VDC	
J10	P-Bus Power Communication from SIB to VIB or between SIB's RJ11	8075555	1	Ground		
			2	P-BUS power	+5VDC	
			3	Modbus RS485 B		
			4	Modbus RS485 A		
			5	Signal ground		
			6	P-BUS power	+12VDC	
J11	Cooking Probe	8263450	1	Ground		Yellow
			2	Probe	3.3VDC	Red

## 1.7.7 Replacing Control Box Components (Smart Interface Board (SIB), transformer, relay)

1. Perform steps 1 through 8 from section 1.9.3.
2. Remove the bezel by removing the two (2) screws on the bottom of the bezel.
3. Disconnect the cables attached to the component marking or making a note of the connectors to facilitate reconnection.
4. Remove the connecting nuts or screws attaching the component.
5. Remove the component from the box. If removing the board, be careful not to lose spacers that fit over the studs behind the board.

**NOTE:** If replacing a filter relay, ensure the 24VDC relay (8074482) is used.

6. Reverse the procedure to install the replacement component. If replacing the SIB board, ensure the spacers behind the board are in place and the controller locator wire is attached to a stud.
7. Reverse above steps to reassemble, complete the replacement and return the fryer to service.

Filter Relay (Left Box Only);  
Reset Switch Relay (Right Box Only)      SIB

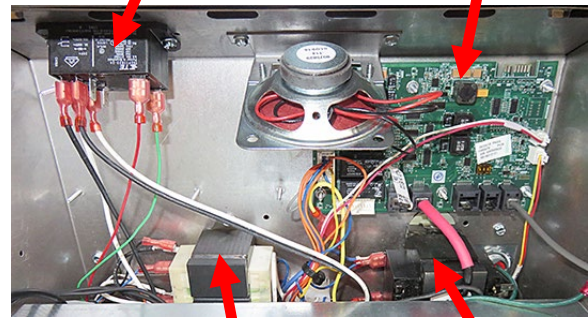

Figure 1

24 VAC (FIB)  
Transformer

24 VAC (SIB)  
Transformer

## 1.8 Improper Temperature Control

Temperature control, including the melt cycle, is a function of several interrelated components, each of which must operate correctly. The principle component is the temperature probe. Other components include the smart interface board (SIB), the controller itself, heat and latch relays, contactors and the elements.

Improper temperature control problems can be categorized into melt cycle problems and failure to control at setpoint problems.

### MELT CYCLE PROBLEMS

Initiation of the melt cycle with FQ4000 controllers is automatic. Problems may originate from the controller itself, the temperature probe, or a malfunctioning heat relay on the SIB (Smart Interface Board) or the SIB (Smart Interface Board).

### FAILURE TO CONTROL AT SETPOINT

Problems in this category may be caused by the temperature probe, the SIB (Smart Interface Board), the controller, loss of power to elements or the loss of a leg of power to the fryer.

### 1.8.1 Thermostats

The fryers are equipped with *temperature probes* located on each element (dual-vat frypots have two probes, one in each vat). In this type of thermostat, the probe resistance varies directly with the temperature. That is, as the temperature rises, so does resistance, at a rate of approximately 2 ohms for every 1° F. Circuitry in the controller monitors the probe resistance and controls element heating when the resistance exceeds or falls below programmed temperatures (set points).

The fryers are also equipped with a *high-limit thermostat*. If the fryer fails to properly control the oil temperature, the high-limit thermostat prevents the fryer from overheating to the flash point. The high-limit thermostat acts as a normally closed power switch that opens when exposed to temperatures above 425°F to 450°F (218°C to 232°C). The different types of high limit thermostats have different part numbers for CE and Non-CE models, and are **NOT** interchangeable.

## 1.8.2 Troubleshooting the Temperature Probe



**Disconnect the temperature probe from the SIB board before testing temperature probe resistances to avoid invalid readings.**

Prior to checking for problems associated with the temperature probe, inspect the probe body for damage while it is still in the frypot. Remove and replace the probe if it is bent, dented, or cracked. Ensure the probe is not touching the element. Also, inspect leads for fraying, burning, breaks, and/or kinks. If found, replace the probe.

The following processes will assist you in troubleshooting the temperature probe and ruling it out as a probable cause:

*Before testing the probe, determine the temperature of the cooking oil using a thermometer or pyrometer placed at the tip of the questionable probe.*

Unplug the temperature probe from the SIB board to test the resistance of the probe.

- **If resistance through the temperature probe is not approximately equal to that given in the Probe Resistance Chart in section 1.8.3 for the corresponding temperature, the probe has failed and must be replaced.**
- **If resistance through temperature probe is approximately equal to that given in the Probe Resistance Chart for the corresponding temperature, measure the resistance through each of the previously tested pins to ground.**
  1. If resistance *is not* 5 mega-Ohms or greater in each pin, the probe has failed and must be replaced.
  2. If resistance *is* 5 mega-Ohms or greater in each pin, the probe is okay.

## 1.8.3 Probe Resistance Chart

Probe Resistance Chart																	
<i>For use with LOV™ Series fryers manufactured with Minco RTD probes only.</i>																	
F	OHMS	C	F	OHMS	C	F	OHMS	C	F	OHMS	C	F	OHMS	C			
60	1059	16	130	1204	54	200	1350	93	270	1493	132	340	1634	171			
65	1070	18	135	1216	57	205	1361	96	275	1503	135	345	1644	174			
70	1080	21	140	1226	60	210	1371	99	280	1514	138	350	1654	177			
75	1091	24	145	1237	63	215	1381	102	285	1524	141	355	1664	179			
80	1101	27	150	1247	66	220	1391	104	290	1534	143	360	1674	182			
85	1112	29	155	1258	68	225	1402	107	295	1544	146	365	1684	185			
90	1122	32	160	1268	71	230	1412	110	300	1554	149	370	1694	188			
95	1133	35	165	1278	74	235	1422	113	305	1564	152	375	1704	191			
100	1143	38	170	1289	77	240	1432	116	310	1574	154	380	1714	193			
105	1154	41	175	1299	79	245	1442	118	315	1584	157	385	1724	196			
110	1164	43	180	1309	82	250	1453	121	320	1594	160	390	1734	199			
115	1174	46	185	1320	85	255	1463	124	325	1604	163	395	1744	202			
120	1185	49	190	1330	88	260	1473	127	330	1614	166	400	1754	204			
125	1195	52	195	1340	91	265	1483	129	335	1624	168	405	1764	207			

## 1.8.4 Replacing the High-Limit Thermostat

1. Drain cooking oil below the level of the high limit thermostat using the controller "drain to pan function".
2. Disconnect the fryer from the electrical power supply or remove fuse on bottom of associated control box and reposition it to gain access to the rear of the fryer.
3. Remove the four screws from both the left and right sides of the lower back panel.
4. Locate the high-limit that is being replaced and follow the two-black wires to the 12-pin connector C-6. Note where the leads are connected prior to removing them from the connector. Unplug the 12-pin connector C-6 and using a pin-pusher push the pins of the high-limit out of the connector.
5. Carefully unscrew the high-limit thermostat to be replaced.
6. Apply Loctite® PST56765 pipe thread sealant or equivalent to the replacement part threads and screw the replacement part into the frypot. Torque the component to 180 inch-pounds.
7. Insert the leads into the 12-pin connector C-6 (see Figure 3). For full-vat units or the left half of a dual-vat unit (as viewed from the rear of the fryer) the leads go into positions 1 and 2 of the connector. For the right half of a dual-vat unit (as viewed from the rear of the fryer), the leads go into positions 7 and 8. In either case, polarity does not matter.

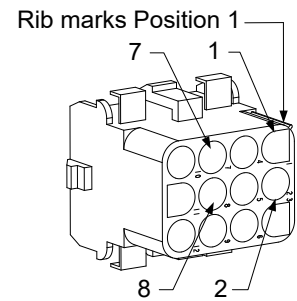

Figure 2

8. Reconnect the 12-pin connecting plug C-6. Use wire ties to secure any loose wires.
9. Reinstall the back panels, contactor plug guards, reposition the fryer under the exhaust hood, and reconnect it to the electrical power supply to return the fryer to service.

### 1.8.5 Replacing the Temperature Probe

1. Drain the cooking oil to the filter pan using the controller “drain to pan function”.
2. Disconnect the fryer from the electrical supply or remove fuse on bottom of associated control box.
3. Reposition the fryer to gain access to the rear of the fryer.
4. Remove the four screws from both sides of the lower back panel. Then remove the two screws on both the left and right sides of the back of the tilt housing. Lift the tilt housing straight up to remove from the fryer.
5. Locate the red, black or yellow and white wires of the temperature probe to be replaced. Note where the leads are connected prior to removing them from the connector. Unplug the 12-pin connector C-6 and using a pin-pusher push the pins of the temperature probe out of the connector.
6. Remove the securing probe bracket and metal tie wraps that secure the probe to the element (see Figures 4 and 5). Remove the ground clip on the probe shield.
7. Gently pull on the temperature probe and grommet, pulling the wires up the rear of the fryer and through the element tube assembly.
8. Insert the replacement temperature probe (wires first) into the tube assembly ensuring that the grommet is in place. Secure the probe to the elements using the bracket which was removed in Step 6 and the metal tie wraps which were included in the replacement kit.
9. Route the probe wires out of the tube assembly following the element wires down the back of the fryer through the Heyco bushings to the 12-pin connector C-6. Secure the wires to the sheathing with wire ties. Attach the ground clip.
10. Insert the temperature probe leads into the 12-pin connector C-6 (see Figure 6). For full-vat units or the right half of a dual-vat unit (as viewed from the rear of the fryer) the red (or yellow) lead goes into position 3 and the white lead into position 4 of the connector. For the left half of a dual-vat unit (as viewed from the rear of the fryer), the red (or yellow) lead goes into position 9 and the white lead into position 10. **NOTE: Right and left** refer to the fryer as viewed from the rear.
11. Secure any loose wires with wire ties, making sure there is no interference with the movement of the springs. Rotate the elements up and down, making sure that movement is not restricted and that the wires are not pinched.
12. Reinstall the tilt housing, back panels and contactor plug guards. Reposition the fryer under the exhaust hood and reconnect it to the electrical power supply to return the fryer to service.



High-Limit Lead Positions

**Figure 3** Temperature Probe

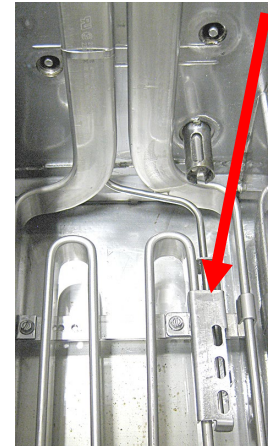

**Figure 4**

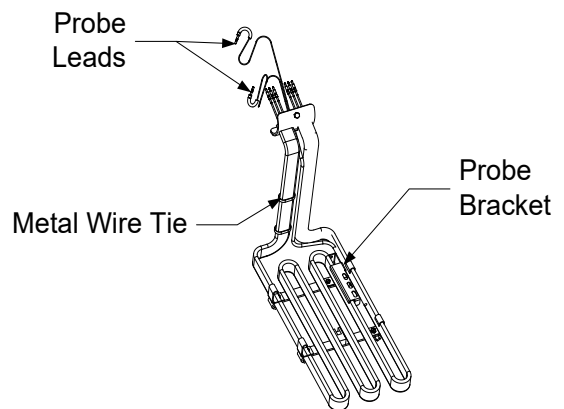

**Figure 5**

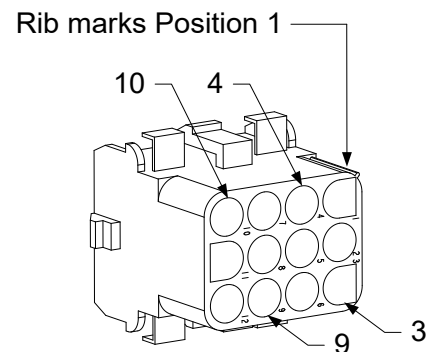

Probe Lead Positions

**Figure 6**

### 1.9 Controller Malfunctions

#### RECOVERY TIME

*Recovery time* – is a method of measuring a fryer’s performance. Put simply, it is the time required for the fryer to increase the oil temperature from 250°F to 300°F (121°C to 149°C). This range is used as a standard since ambient kitchen temperatures can affect the test if lower ranges are used.

The FQ4000 controller performs the recovery test each time the fryer warms up. An operator can view the results of the test any time the fryer is above the 300°F (149°C) point by pressing the ? button and then pressing the **RECOVERY** button

when the fryer is on. The test results will be displayed in minutes and seconds. The maximum acceptable recovery time for FQE30-T electric fryers is one minute and forty seconds (1:40) for liquid shortening and three minutes (3:00) for solid shortening. If the recovery is high, check to ensure that the fryer 3-phase plugs are fully seated into the receptacle. Check to ensure that power is present across all legs of the breakers, receptacle, contactors and elements.

### 1.9.1 FQ4000 Controller Troubleshooting

Problem	Probable Causes	Corrective Action
<b>No Display on Controller.</b>	<ul style="list-style-type: none"> <li>A. No power to the fryer.</li> <li>B. Controller has failed.</li> <li>C. Damaged controller wiring harness.</li> <li>D. Power supply component or SIB (Smart Interface Board) has failed.</li> <li>E. Damaged harness between VIB board and SIB board.</li> </ul>	<ul style="list-style-type: none"> <li>A. Verify all power cords are plugged in and that circuit breaker is not tripped.</li> <li>B. Swap the controller with a controller known to be good. If controller functions, replace the controller.</li> <li>C. Swap with a harness known to be good. If controller functions, replace the harness.</li> <li>D. If any component in the power supply system (including the transformer and SIB Smart Interface Board) fail, power will not be supplied to the controller and it will not function.</li> <li>E. Ensure that the wires of the harness are not shorted.</li> </ul>
<b>Controller locks up.</b>	Controller error.	Remove and restore power to the fryer (controller).
<b>FQ4000 displays E45 RECOVERY FAULT.</b>	Recovery time exceeded maximum time limit for two or more cycles.	Silence the alarm by pressing the check button. Check that fryer is heating properly. Maximum recovery for electric is one minute and forty seconds (1:40) for liquid shortening and three minutes (3:00) for solid shortening. See Section 1.9 for an explanation of recovery time.
<b>FQ4000 displays E61 MISCONFIGURED ENERGY TYPE</b>	Wrong energy type selected in service settings.	Press home button. Press Settings button. Press Service button. Enter 3000. Press Energy Type and select correct energy type.
<b>FQ4000 displays UNABLE TO READ USB DRIVE</b>	Defective USB drive	Replace USB drive with USB drive.
<b>FQ4000 displays FILE NOT FOUND</b>	Missing files on USB drive	Ensure correct files are on USB drive.
<b>FQ4000 displays SOFTWARE UPDATE CANCELLED - RESTART THE SYSTEM</b>	<ul style="list-style-type: none"> <li>A. USB drive removed during software update.</li> <li>B. Power loss during a software update.</li> </ul>	<ul style="list-style-type: none"> <li>A. Restart the system and reload the software ensuring that the USB drive is not removed until prompted to do so.</li> <li>B. Reload the software from USB drive.</li> </ul>
<b>QUICK FILTER or CLEAN AND FILTER won't start.</b>	Temperature too low.	Ensure fryer is at 310F (154C) before starting <b>QUICK FILTER</b> or <b>CLEAN AND FILTER</b> .
<b>FQ4000 displays SERVICE REQUIRED with the type of error.</b>	An error has occurred.	Press YES to silence alarm. The error is displayed three times. See list of issues in section 1.4. Fix issue. The controller displays <b>SYSTEM ERROR FIXED? YES/NO</b> . Press YES. Controller displays <b>ENTER CODE</b> . Enter 1111 to clear error code. Pressing NO will allow the fryer to cook but error will be redisplayed every 15 minutes.
<b>FQ4000 display is in wrong temperature scale (Fahrenheit or Celsius).</b>	Incorrect display option programmed.	Press home button. Press Service button. Press Service button again. Enter 3000. Press Tech Modes. Press Toggle to Select. Press F° to C° to toggle temperature scale. Press YES to confirm. Press check to complete. Press home to exit.
<b>FQ4000 displays VAT ID CONNECTOR NOT CONNECTED</b>	Vat ID locator connector unplugged from UI or grounded position in control box.	Ensure that the vat locator connector is properly connected to UI harness and ensure that ground on harness is properly grounded to control box.

<b>Problem</b>	<b>Probable Causes</b>	<b>Corrective Action</b>
<b>FQ4000 displays NO MENU GROUP AVAILABLE FOR SELECTION</b>	All menu groups have been deleted.	Create a new MENU group. Once a new menu is created, add recipes to the group (see section 4.10 of the IO manual).
<b>FQ4000 displays CHANGE FILTER PAD.</b>	Filter error has occurred, filter pad clogged, 24-hour filter pad change prompt has occurred or change filter pad was ignored on a prior prompt.	Change the filter pad and ensure the filter pan has been removed from the fryer for a minimum of <b>30</b> seconds. Do <b>NOT</b> ignore <b>CHANGE FILTER PAD</b> prompts.
<b>FQ4000 displays E16 HIGH LIMIT 1 EXCEEDED.</b>	Frypot temperature is more than 410°F (210°C) or, in CE countries, 395°F (202°C).	This is an indication of a malfunction in the temperature control circuitry, including a failure of the high-limit thermostat during normal operation.
<b>FQ4000 displays E17 HIGH LIMIT 2 EXCEEDED.</b>	Frypot temperature is high enough to open the physical bi-metallic high limit switch or the switch has failed.	This is displayed when the oil temperature is above 425°F (218°C) and the high-limit thermostat has opened, halting the heating of the oil. Let the high limit cool to determine if the switch closes. Check high limit resistance.
<b>FQ4000 displays E18 HIGH LIMIT PROBLEM – DISCONNECT POWER – CALL SERVICE.</b>	Failed high-limit.	This is displayed to indicate the high-limit has failed.
<b>FQ4000 displays HOT-HI 1.</b>	Controller in high-limit test mode.	This is displayed only during a test of the high-limit circuit and indicates that the frypot temperature is more than 410°F (210°C) or, in CE countries, 395°F (202°C).
<b>FQ4000 displays HELP HI-2.</b>	Controller in high-limit test mode.	This is displayed only during a test of the high-limit circuit and indicates that the high-limit has opened properly.
<b>FQ4000 displays HIGH LIMIT FAILURE DISCONNECT POWER.</b>	Controller in high-limit test mode. Failed high-limit.	This is displayed during a test of the high limit to indicate the high-limit has failed.
<b>FQ4000 displays INSERT PAN.</b>	<ul style="list-style-type: none"> <li>A. Filter pan is not fully inserted into fryer.</li> <li>B. Missing filter pan magnet.</li> <li>C. Defective filter pan switch.</li> </ul>	<ul style="list-style-type: none"> <li>A. Pull filter pan out and fully reinsert into fryer.</li> <li>B. Ensure the filter pan magnet is in place and if missing replace.</li> <li>C. If the filter pan magnet is fully against the switch and controller continues to display <b>INSERT PAN</b>, switch is possibly defective.</li> </ul>
<b>FQ4000 displays MELT CYCLE IN PROGRESS.</b>	Frypot temperature is below 180°F (82°C).	This display is normal when the fryer is first turned on while in the melt cycle mode. To bypass the melt cycle press <b>BYPASS MELT CYCLE</b> button next to the <b>PREHEAT</b> . The controller displays <b>PREHEAT</b> while heating to setpoint. If the display continues, the fryer is not heating.
<b>FQ4000 displays PREHEAT.</b>	Frypot temperature is above 180°F (82°C).	This display is normal when the fryer is above 180°F (82°C) but below setpoint. If the display continues, the fryer is not heating.
<b>FQ4000 displays E13 TEMPERATURE PROBE FAILURE CALL SERVICE.</b>	<ul style="list-style-type: none"> <li>A. Problem with the temperature measuring circuitry including the probe.</li> <li>B. Bad Connection</li> </ul>	<ul style="list-style-type: none"> <li>A. This indicates a problem within the temperature measuring circuitry. Check resistance of probe, if faulty replace probe.</li> <li>B. Ensure temperature probe is connected properly to SIB board. Ensure that the connector is terminated properly.</li> </ul>

Problem	Probable Causes	Corrective Action
<b>FQ4000 displays E19 HEATING FAILURE</b>	A. Heat or latch circuit failed. B. SIB failure C. Open high limit thermostat	A. Check the heat or latch circuit. B. Replace the SIB board. C. Ensure high limit thermostat is not open.
<b>FQ4000 displays software for only FQ4000, SIB, VIB or FIB but not all boards.</b>	Loose or damaged harness	Check that all harnesses between FQ4000's, SIB, VIB and FIB are secure. Check for loose or broken pins/wires. If the problem persists, swap out controller from one bank to another and cycle power on the fryer.
<b>FQ4000 displays IS VAT FULL? YES NO.</b>	A. Normal operation during most at the beginning or end of most filtration functions. B. If the display appears many times during a filter it could be an indication of slow oil return C. A filter error has occurred due to dirty or clogged filter pad or paper, clogged pre-filter, clogged filter pump, filter pump thermal overload, improperly installed filter pan components, worn or missing O-rings, cold oil or an actuator problem.	A. Ensure the vat is full of oil and press the √ button. B. See section 1.10.3 troubleshooting –Filter Pump runs, but oil return is very slow. C. Ensure the filter pad/paper is clean, pre-filter is clean; O-rings are present and not worn; filter pump overload is not tripped.

### 1.9.2 FQ4000 Controller Functional Troubleshooting

There are four (4) LED status lights on the rear of the controller which provide a quick method to verify power and touch screen functionality on the FQ4000 controller.

To verify that the FQ4000 has power and the touch screen is functional, remove the 2 screws attaching the controller to the bezel. Lower the controller to view the LED's on the rear of the controller board. Verify that the three (3) green LED's are illuminated which indicate that 3V, 5V and 12V power is present on the controller. These should be illuminated at all times. Pressing anywhere on the front of the touch screen will illuminate the red LED STATUS (see Figure 7). The red LED will also illuminate momentarily during power up.

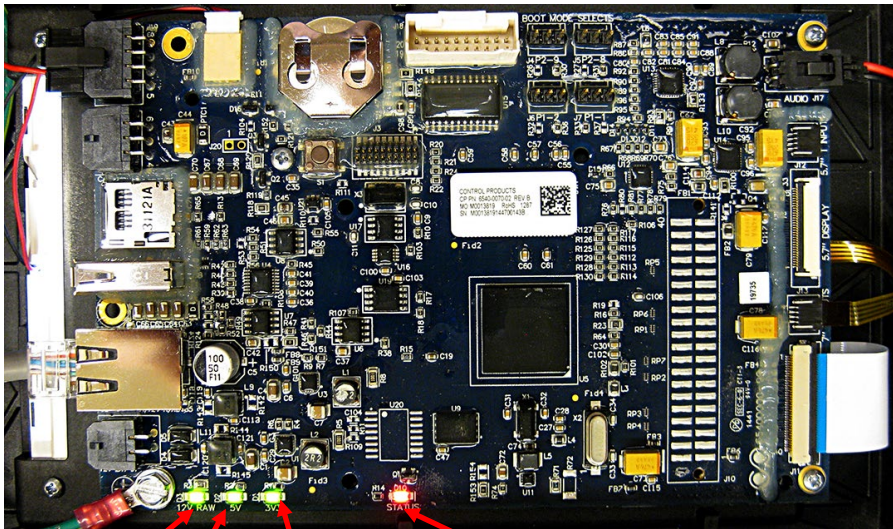

**Figure 7**  
 12V from SIB  
 5V from SIB  
 3V from power supply on UIB  
 When the touch screen is pressed, the STATUS LED illuminates RED.

### 1.9.3 Replacing the Controller or the Controller Wiring Harnesses

1. **Disconnect the fryer from the electrical power supply. The fuse located at the bottom of the control box can be removed to remove power from individual control boxes.**
2. The controller is held in place by two screws in upper corners.
3. Remove the two screws from the upper corners of the controller.
4. Slide the controller up and it will swing open from the top.
5. The controller will slide up through the protective cage.
6. Disconnect the RJ45 cable from the SIB board first.
7. Disconnect the other cables from the connectors on the back of the controller marking their position for reassembly.
8. Disconnect the lanyard tether.
9. Remove the controller. The controller will slide up and out of the controller protector cage.

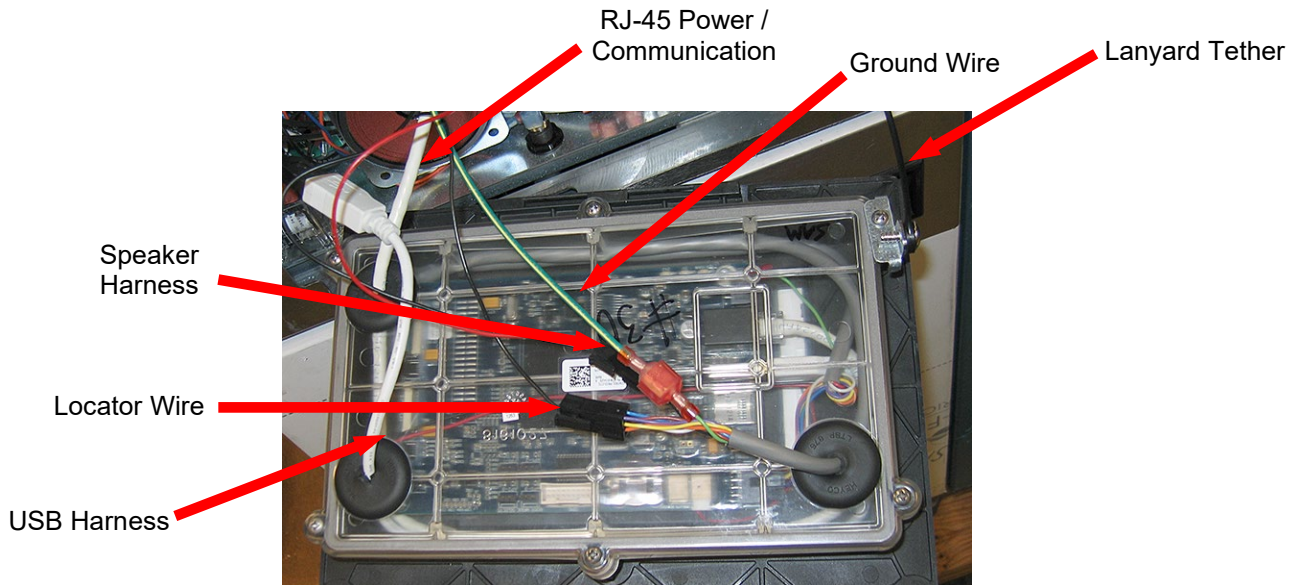

**Figure 8**

10. With the replacement controller face down resting in the control box, **reattach the lanyard tether FIRST**. Failure to reinstall lanyard may result in damage to the SIB board.
11. Reinstall the controller by reversing steps 1 thru 7. **NOTE: Common controllers won't require the locator wire. Tuck back into the control box. Common controllers vat ID is set up in Settings>Tech Service>Vat ID.**
12. Setup the controller following the instructions in section 4.7 of the FQE30-T Installation and Operation manual. If the controller being replaced is in the far-left position, the current date and time will need to be setup following the instruction in section 4.8 of the Installation and Operation manual. Setup **MUST** be performed prior to readdress.
13. Once setup is complete on all replaced controllers, CYCLE POWER TO **ENTIRE** FRYER SYSTEM. See section 1.13 to cycle control power.
14. Check software version by pressing the information (?) button; press the down arrow; press the SW version button. The controller displays INTIALIZING. Ensure that the FQ4000 (UIB)/VIB/FIB/SIB/OQS software versions match the other controllers. If the software versions do not match, update the software. If a software update is necessary, follow the instructions to update the software in section 1.15.

## 1.10 Filtration Malfunctions

### 1.10.1 Built-in Filtration System Service Procedures

Most filtration problems arise from operator error. One of the most common errors is placing the filter paper/pad on the bottom of the filter pan rather than over the filter screen.

Whenever the complaint is “the pump is running, but no oil is being filtered,” check the installation of the filter paper/pad, including that the correct size is being used. While you are checking the filter paper/pad, verify that the O-rings on the filter pan suction tube are present and in good condition. Missing or worn O-rings will allow the pump to suck air and decrease its efficiency. Also check the pre-filter. A plugged pre-filter (see Figure 9) can slow the flow of oil. Use the attached wrench to open (see Figure 10) and clean the pre-filter (see Figure 11).

If the pump motor overheats, its thermal overload will trip and the motor will not start until it is reset. If the pump motor does not start, press the red reset switch located on the front of the motor. If the pump starts, something caused the motor to overheat. It may be attributed to several frypots in a large battery of fryers being filtered one after the other and the pump overheated. Letting the pump cool down for at least a half-hour is all that is required in this case. Often, the pump overheated for one of the following reasons:

- Shortening that remained in the pan after previous filtering solidified in the suction tube recess in the bottom of the pan or the suction tube, itself. Adding hot oil to the pan and waiting a few minutes will usually correct this problem. A flexible wire can be used to clean out the suction tube and the recess in the bottom of the pan. **NEVER** use compressed air to blow solidified shortening out of the suction tube!
- The operator attempted to filter oil that was not heated. Cold oil is thicker and causes the pump motor to work harder and overheat.



Figure 9

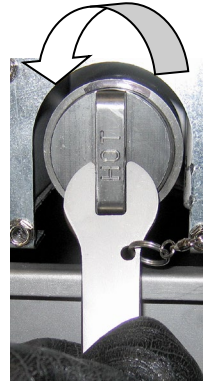

Figure 10

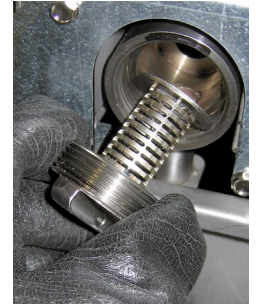

Figure 11

#### CAUTION

**Ensure that filter screen is in place prior to filter pad/paper placement and filter pump operation. Improper screen placement is the primary cause of filtration system malfunction.**

### 1.10.2 Filtration System Problem Resolution

If the motor hums but the pump does not rotate, there is a blockage in the pump. Incorrectly sized or installed paper/pad will allow food particles and sediment to pass through the filter pan and into the pump. When sediment enters the pump, the gears can bind up and cause the motor to overload, tripping the thermal overload. Solidified shortening in the pump will also cause it to seize, with similar results.

A pump seized by debris or hard shortening can usually be freed by manually moving the gears with a screwdriver or other instrument as illustrated in Figure 12. **Ensure power to the pump motor is off before trying this.**

1. Disconnect power to the filter system.
2. Remove the input plumbing from the pump.
3. Use a screwdriver to manually turn the gears (see Figure 12).
  - Turning the pump gears backwards will release a hard particle and allow its removal.
  - Turning the pump gears forward will push softer objects and solid shortening through the pump and allow free movement of the gears.

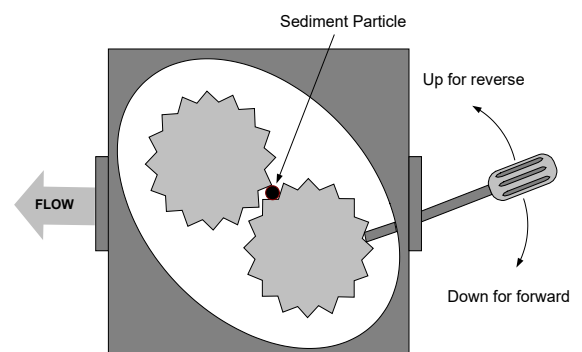

Figure 12

Incorrectly sized or installed filter paper/pads will also allow food particles and sediment to pass through and clog the suction tube on the bottom of the filter pan. Particles large enough to block the suction tube may indicate that the crumb tray is not being used. Pan blockage can also occur if shortening is left in the pan and allowed to solidify. Blockage removal can be accomplished by forcing the item out with an auger or drain snake. Compressed air or other pressurized gases should not be used to force out the blockage.

### 1.10.3 Filtration Troubleshooting

Problem	Probable Causes	Corrective Action
<b>QUICK FILTER/CLEAN and FILTER won't start.</b>	<ul style="list-style-type: none"> <li>A. Filter pan out of position.</li> <li>B. Oil level too low.</li> <li>C. Oil temperature is too low (OIL TOO COLD display).</li> <li>D. Filter relay has failed.</li> <li>E. Filter motor thermal switch is tripped.</li> <li>F. Filter in recipe setup is set to OFF (QUICK FILTER only).</li> <li>G. Filter After set to "0".</li> <li>H. Filtration Lockout set to ENABLED.</li> <li>I. Error in system.</li> </ul>	<ul style="list-style-type: none"> <li>A. Ensure filter pan is fully inserted into fryer. If the controller displays a "P" the pan is not fully engaged into the pan switch.</li> <li>B. Ensure the oil level is above the top oil level sensor.</li> <li>C. Ensure the oil temperature is above 310F (154C).</li> <li>D. Replace filter relay with part number <a href="#">8074482</a> 24VDC relay if defective.</li> <li>E. Press filter motor thermal reset switch.</li> <li>F. Set Filter in recipe setup to ON.</li> <li>G. Set Filter After to 12 for full vat or 6 for split vat (QUICK FILTER Filtration only).</li> <li>H. Set Filtration Lockout to DISABLED.</li> <li>I. Ensure that no error exist in system. Check error log for errors. Power cycle the fryer.</li> </ul>
<b>No power present at the FIB board</b>	See No Power to FIB board in section 1.11.1.	See No Power to FIB board in section 1.11.1.
<b>Fryer filters after each cook cycle.</b>	Filter after setting incorrect.	Change or overwrite the filter after setting by re-entering the filter after value in Manager Settings, Filter Attributes in section 4.8 in the FQE30-T IO Manual.
<b>FIB will not clear error.</b>	Error remains in non-volatile memory.	Press home button. Press service. Press service again. Enter 3000 and press check. Press down arrow button. Press FIB2 reset. Press yes. Press the check. Press home button to exit. Ensure that at CHANGE FILTER PAD the pan is out for at least 30 seconds to clear message.
<b>FQ4000 displays FILTER BUSY.</b>	<ul style="list-style-type: none"> <li>A. Another filtration cycle or filter pad change is still in process.</li> <li>B. Filter interface board has not cleared checking system.</li> </ul>	<ul style="list-style-type: none"> <li>A. Wait until the previous filtration cycle ends to start another filtration cycle or until the FIB board has reset. This may take up to one minute. Change filter pad if prompted.</li> <li>B. Wait 15 minutes and try again. If filter busy is still displayed with no activity, ensure the filter pan is empty and remove and restore <b>ALL</b> power to the fryer.</li> </ul>
<b>Drain valve or return valve stays open.</b>	<ul style="list-style-type: none"> <li>A. Valve Interface Board has failed.</li> <li>B. Actuator has failed.</li> <li>C. Power supply failed.</li> </ul>	<ul style="list-style-type: none"> <li>A. Ensure that the VIB and FIB board software versions are present to indicate communication.</li> <li>B. Ensure the actuator is properly connected and functioning.</li> <li>C. Ensure power supply is functioning correctly in FIB box. Check VIB for proper voltages using pin position chart in section 1.12.2.</li> </ul>

Problem	Probable Causes	Corrective Action
<b>Filter pump won't start or pump stops during filtering.</b>	<ul style="list-style-type: none"> <li>A. Power cord is not plugged in or circuit breaker is tripped.</li> <li>B. Pump motor has overheated causing the thermal overload switch to trip.</li> <li>C. Blockage in filter pump.</li> </ul>	<ul style="list-style-type: none"> <li>A. Verify that the power cord is fully plugged in and the circuit breaker is not tripped.</li> <li>B. If the motor is too hot to touch for more than a few seconds, the thermal overload switch has probably tripped. Allow the motor to cool at least 45 minutes then press the Pump Reset Switch.</li> <li>C. Ensure filter pump is functioning properly and no blockages exist.</li> </ul>
<b>FQ4000 displays INSERT PAN.</b>	<ul style="list-style-type: none"> <li>A. Filter pan is not fully set into fryer.</li> <li>B. Missing filter pan magnet.</li> <li>C. Defective filter pan switch.</li> </ul>	<ul style="list-style-type: none"> <li>A. Pull filter pan out and fully reinsert into fryer. Ensure controller does not display "P".</li> <li>B. Ensure the filter pan magnet is in place and replace if missing.</li> <li>C. If the filter pan magnet is fully against the switch and controller continues to display INSERT PAN or "P", switch is possibly defective.</li> </ul>
<b>Filter Pump runs, but oil return is very slow.</b>	<ul style="list-style-type: none"> <li>A. Improperly installed or prepared filter pan components.</li> <li>B. Pre-filter screen may be clogged.</li> </ul>	<ul style="list-style-type: none"> <li>A. Remove the oil from the filter pan and replace the filter pad, ensuring that the filter screen is in place <b>under</b> the pad. Verify, if using a pad, that the rough side is facing up. Verify that O-rings are present and in good condition on filter pan connection fitting.</li> <li>B. Clean pre-filter screen.</li> </ul>

#### 1.10.4 FIB (Filter Interface Board) Service Procedures

The controller has a service mode that allows manually opening of return and drain valves, manual operation of the filter pump motor and the ATO pump.

To access the mode, follow these steps:

1. Press the Home button.
2. Press the Service button.
3. Press the Service button again.
4. Enter 3000 and press the checkmark.
5. Press Manual Filtration button.

The controller displays the current state of the valves and pump under the titles (see Figure 13). Pressing the buttons will perform the action inside the button.

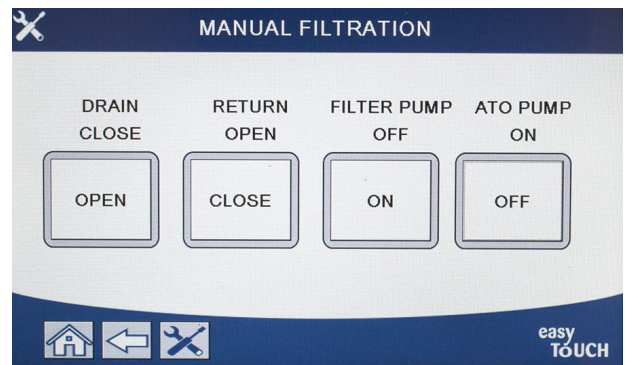

Figure 13

#### 1.10.5 Manually Draining, Refilling, Filtering or Topping off using the Manual Filtration Mode

Pressing the drain button or the return button activates the drain or return valve for the associated vat. Pressing the filter pump button or ATO pump button activates the pumps. **NOTE: The pumps will not activate unless a return valve is opened to prevent deadheading of the pumps.**

Pressing the home button exits the manual filtration mode. Upon exiting the manual filtration mode, the controller will prompt to FILL VAT FROM DRAIN PAN? YES/NO to ensure no oil is left in the filter pan. Follow the prompts to ensure all oil is returned to the vat.

### 1.10.6 Replacing the Filter Motor or Filter Pump

1. Disconnect the fryer from the electrical power supply and reposition it to gain access to both the front and rear.
2. Remove the filter pan and lid from the unit.
3. Remove the lower back panel.
4. Disconnect the flexline running to the oil-return manifold at the rear of the fryer as well as the pump suction flexline at the end of the filter pan connection.
5. Remove the cover plate from the front of the motor and disconnect the motor wires.
6. Remove the nuts and bolts which secure the filter pump motor bridge to the rear vertical brace.
7. Remove the screws that secure the bridge to the lower rear brace.
8. Remove the nut which secures the front of the bridge to the brace.
9. Get a good grip on the bridge, carefully pull it forward off the rear brace and lower the entire assembly to the floor. Once on the floor, pull the assembly out the front of the fryer.
10. When required service has been completed, reverse steps 2-9 to reinstall the bridge.
11. Reconnect the unit to the electrical power supply, and verify that the pump is functioning correctly using the functions in the filter menu (i.e., using the fill vat from pan function when engaged, the motor should start and there should be strong suction at the intake fitting and outflow at the rear flush port.)
12. When proper operation has been verified, reinstall the back panels and the filter pan and lid.
13. Reposition the fryer under the exhaust hood to return the fryer to service.

### 1.11 ATO (Automatic Top-off) and Filtration Malfunctions and Service Procedures

The automatic top-off system is activated when the oil level falls below the top sensor in the front of the frypot. The signal is sent to the FIB (Filter Interface Board) which sends a signal to the VIB (Valve Interface Board) to engage the return actuator to the frypot and turn on the ATO pump. The pump draws oil from the JIB (Jug In Box) through the rear return manifold into the rear of the frypot. Once the oil level has satisfied the sensor, the pump turns off and the actuator closes.

The FIB (Filter Interface Board) also oversees and controls filtration and bulk oil functions. It receives and sends data over the CAN (Controller Area Network) to and from various sensors, boards and controllers. It activates the filtration cycle sending information to the VIB (Valve Interface Board) boards controlling when actuators should open and close.

The FIB board is located inside the box, behind the oil reservoir (see Figure 17). The power for the FIB board, the filter pump relay, and top off pump are supplied from the 24VDC power supply in the FIB box. The 24VDC power supply also provides power, which passes through the FIB board to the VIB board, to the rotary actuators. The power for the VIB board microprocessor is supplied from the SIB.

The 24VAC transformer in the left component box powers the fresh oil solenoid for bulk oil.

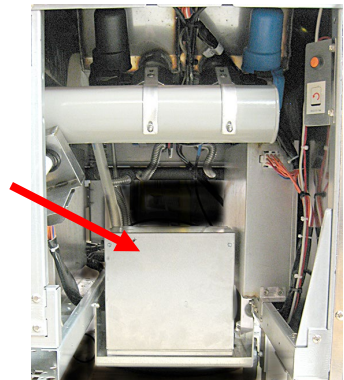

Figure 17

#### 1.11.1 Auto Top Off Troubleshooting

Problem	Probable Causes	Corrective Action
<b>Fryer tops off cold.</b>	Incorrect setpoint.	Ensure setpoint is correct.
<b>No power to FIB board</b>	A. J1 connection unplugged. B. Power supply malfunction.	A. Check to ensure J1 on front of FIB board is fully locked into connector. B. Check that proper voltage is present at the power supply. See table in section 1.11.4.
<b>Incorrect vat tops off.</b>	A. Wired incorrectly. B. Flex lines connected to wrong vat.	A. Check wiring. Ensure the ATO probes are connected to correct vat and harness positions. B. Ensure the correct flex lines are connected to correct vat.

Problem	Probable Causes	Corrective Action
<b>One vat doesn't top off.</b>	<ul style="list-style-type: none"> <li>A. Filter error exists.</li> <li>B. Actuator, pump, loose connection, RTD or FIB issue.</li> </ul>	<ul style="list-style-type: none"> <li>A. Clear filter error properly. When "CHANGE FILTER PAD YES/NO" is displayed, do NOT press any button until the pan has been removed for at least <b>thirty seconds</b>. After thirty seconds the controller returns to OFF or previous display.</li> <li>B. Check actuator, ATO pump, FIB board, wire connections and RTD.</li> </ul>
<b>One vat tops off but other vats fail to top off.</b>	<ul style="list-style-type: none"> <li>A. Loose wire connection.</li> <li>B. Actuator issue.</li> <li>C. Actuator connector issue.</li> </ul>	<ul style="list-style-type: none"> <li>A. Ensure all wiring harnesses are securely connected to SIB and FIB board.</li> <li>B. Check return actuator to ensure actuator is functional.</li> <li>C. Ensure return actuator connector is fully seated into VIB board.</li> </ul>
<b>The yellow low oil reservoir indicator won't illuminate.</b>	<ul style="list-style-type: none"> <li>A. ATO probe issue</li> <li>B. Dirty ATO probe</li> <li>C. Probe connection</li> </ul>	<ul style="list-style-type: none"> <li>A. With ATO probe covered in oil, press the "?" button. Press the down arrow. Press Software Version. Press the down arrow and ensure actual vat temperature and ATO RTD temperature are relatively close.</li> <li>B. Ensure the ATO probe is clean and sediment is not present in probe cavity.</li> <li>C. Ensure the ATO probe is properly connected to SIB board.</li> </ul>
<b>FQ4000 displays E29 - TOP OFF PROBE FAILURE - CALL SERVICE</b>	<ul style="list-style-type: none"> <li>A. Shorted or Open ATO RTD probe</li> <li>B. Bad Connection</li> </ul>	<ul style="list-style-type: none"> <li>A. With ATO probe covered in oil, press the "?" button. Press the down arrow. Press Software Version. Press the down arrow and ensure actual vat temperature and ATO RTD temperature are relatively close. If temperature reading is missing, unplug the ATO probe from the SIB board and check ATO probe resistance. If probe is bad, replace the probe.</li> <li>B. Ensure ATO probe is connected properly to SIB board. Ensure that the connector is terminated properly.</li> </ul>

Problem	Probable Causes	Corrective Action
<p><b>FQ4000 displays E64 - FILTRATION INTERFACE BOARD FAILURE - FILTRATION AND TOP OFF DISABLED - CALL SERVICE</b></p>	<p>A. Bad Connection/Defective SUI Board.  B. FIB Board power loss.  C. FIB board failure.</p>	<p>A. Enter the INFO mode, and select SOFTWARE, review the FIB software status. If FIB: 00.00.000 is shown, the communication is lost between the FIB and SIB or the CAN bus is loaded down. This can be caused by a defective SUI board (if installed). Unplug the SUI board. If FIB software version returns, terminate the plug in FIB board where SUI was connected until the SUI board can be replaced.</p> <p>B. Cycle power off for 30 seconds or longer using the master power reset switch.</p> <p>C. Repeat step A to check if a software version is shown other than zeros. If zeros are still present, skip to step D.</p> <p>D. Perform an FIB 2 RESET from the SERVICE - SERVICE menu.</p> <p>E. Repeat step A to check if a software version is shown other than zeros. If zeros are still present, skip to step F.</p> <p>F. Ensure CAN connections between the SIB board on far-right vat and FIB board are secure. (Pressing the ? button shall display the FIB software version. If a software version of V00.00.000 is displayed and the FIB has power, a communication issue may be the cause.).</p> <p>G. Repeat step A to check if a software version is shown other than zeros. If zeros are still present, skip to step H.</p> <p>H. Ensure CAN connections between the SIB board vat 1 to SIB board vat 2 to SIB board vat 3 are all secure. Note: If the error is only showing on vat 1 there is a communication break between vat 1 &amp; 2. If the error is showing up on vat 1 and 2 then the error is in between vat 2 &amp; 3. If the error is showing on all pots there is connection issue from vat 3 or higher to the FIB board; or the board is not getting power; or the board is not operational any longer and needs to be replaced.</p> <p>I. Repeat step A to check if a software version is shown other than zeros. If zeros are still present, skip to step J.</p> <p>J. Review the remote logger connection at the back of the fryer if applicable and ensure the cabling to the remote monitor has not been damaged. If damaged, remove the cable and install the terminator into the wire harness connection (terminator zip tied to the cable mounting bracket).</p> <p>K. If the terminator was installed, repeat steps A thru E to see if communication is reestablished. If zeros are still present in INFO - SOFTWARE-FIB, move to step L.</p>

Problem	Probable Causes	Corrective Action
<p>Continued from previous page.</p> <p><b>FQ4000 displays E64 - FILTRATION INTERFACE BOARD FAILURE - FILTRATION AND TOP OFF DISABLED - CALL SERVICE</b></p>		<p>L. Power to the FIB board has been lost. Ensure there is correct voltage to the FIB power supply and from the FIB power supply. Restore power to the board and clear any service required errors. Replace FIB power supply. If the FIB board has a red led illuminated, power is present at the FIB board.</p> <p>M. If power is supplied at the FIB board in step L and all the other steps above still reflect the E64, then replace FIB board. After replacing the FIB board, reset the system by powering the entire battery down for 30 seconds.</p>
<p><b>Frypots won't top off.</b></p>	<p>A. Empty oil reservoir.</p> <p>B. ATO lines/pump obstruction.</p> <p>C. ATO probe temperature lower than setpoint.</p> <p>D. Oil is too cold.</p> <p>E. Bad Connection</p> <p>F. SIB, VIB or FIB power loss</p> <p>G. Failed power supply/harness.</p> <p>H. ATO pump failed.</p> <p>I. Failed FIB board.</p> <p>J. Failed VIB board.</p>	<p>A. Ensure oil reservoir has oil.</p> <p>B. Ensure the lines/ATO pump is not obstructed.</p> <p>C. Check to see that fryer is heating. Fryer temperature must be at setpoint. With ATO probe covered in oil, press the "?" button. Press the down arrow. Press Software Version. Press the down arrow and ensure actual vat temperature and ATO RTD temperature are relatively close. Unplug the ATO probe from the SIB board and check ATO probe resistance. If probe is bad, replace the probe.</p> <p>D. Ensure that the oil in the oil reservoir is above 70°F (21°C).</p> <p>E. Press the information (?) button; press the down arrow; press the SW version button. Ensure the SIB, VIB and FIB software versions appear. If not, the connection between the VIB and the SIB board or between the SIB and FIB may be bad. Ensure the P-BUS connectors are tight between VIB (J2) and SIB (J9 or J10) or between SIB (J7 or J8) and FIB (J3 or J4) boards.</p> <p>F. Power to the SIB, VIB or FIB has been cut off. Restore power to the board and clear any service required errors.</p> <p>G. Ensure power supply in FIB box is functioning properly. Ensure all harnesses are plugged securely into place.</p> <p>H. Ensure ATO pump is operational. Check voltage to ATO pump. Replace the ATO pump if defective.</p> <p>I. Check FIB for proper voltages using the pin position chart found in section 1.11.4. If FIB found defective, replace FIB board. <b><u>DO NOT CHECK WITH HARNESSES UNPLUGGED AS SHORTING THE PINS MAY OCCUR WHICH WILL DAMAGE THE BOARD.</u></b></p> <p>J. Check VIB for proper voltages using pin position chart in section 1.12.2. If VIB found defective, replace VIB board. <b><u>DO NOT CHECK WITH HARNESSES UNPLUGGED AS SHORTING THE PINS MAY OCCUR WHICH WILL DAMAGE THE BOARD.</u></b></p>

## 1.11.2 Test Points on rear of FIB Box

### 1.11.2.1 12-pin connector on rear of FIB (Filter Interface Board) box (C7)

Use these test points for troubleshooting.

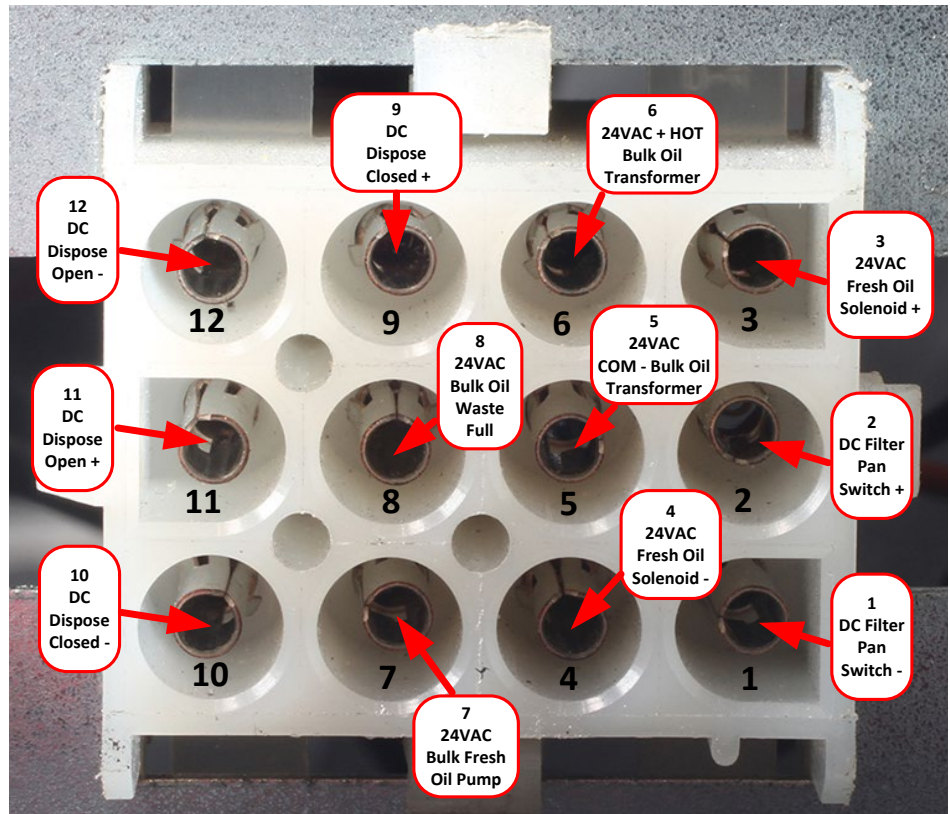

Figure 18

### 1.11.2.2 Connections on rear of FIB (Filter Interface Board) box

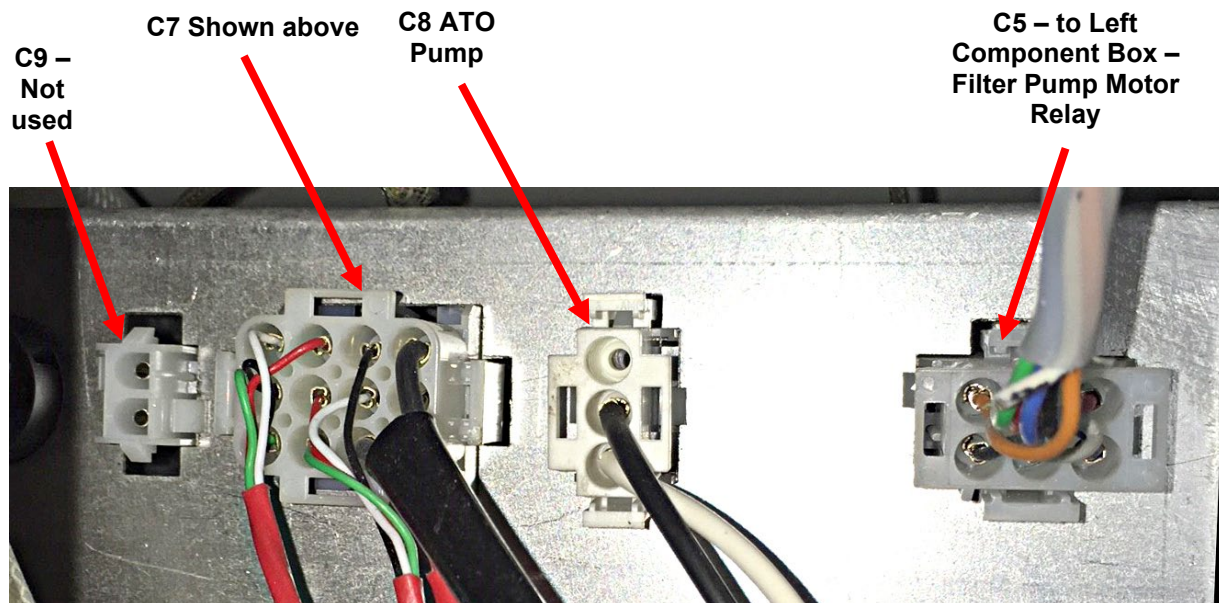

Figure 19

### 1.11.3 FIB (Filter Interface Board) LED's and Test Points

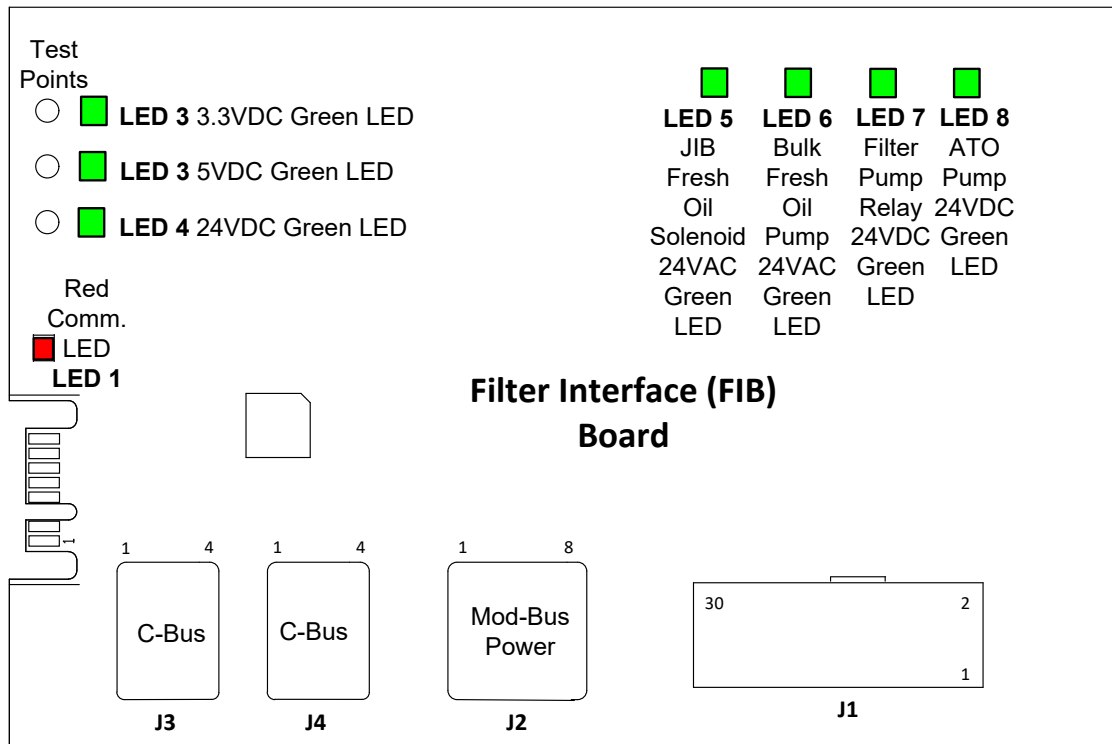

Figure 20

### 1.11.4 FIB (Filter Interface Board) Filtration and Top-off Pin Positions and Harnesses

**NOTE: DO NOT CHECK WITH HARNESES UNPLUGGED AS SHORTING THE PINS MAY OCCUR WHICH WILL DAMAGE THE BOARD.**

Connector	From/To	Harness #	Pin #	Function	Voltage	Wire Color		
J1	Input from Power Supply	8076240	1	Ground -		Brown		
			2	24VDC Input	+24VDC	Purple		
			3	Ground -		Brown		
			4	24VDC Input	+24VDC	Purple		
	JIB Reset Switch		5	Ground -	3.3VDC	Black		
			6	JIB Low Reset		Red		
	Filter Pump Relay		9	Pump Motor +	24VDC	Purple		
			10	Pump Motor -		Brown		
	Pan Switch		13	Pan Sw Ground -	3.3VDC	Red		
			14	Pan Sw +		Red		
	ATO Pump		15	Pump Ground -	24VDC	Purple		
			16	ATO Pump		Brown		
	Input from 24VAC Transformer		17	24VAC	24VAC	Orange		
			18	24VAC Ret		Blue		
	To RTI JIB Add Solenoid		19	24VAC	24VAC	Black		
			20	24VAC Ret		Black		
	RTI connector rear of fryer		21	From RTI transformer (1 on Hirschman)	24VAC	Orange		
			22	Common (Ret) (4 on Hirschman)		Blue		
			23	To RTI Fresh Oil Relay (3 on Hirschman)	24VAC	Orange		
			24	From RTI "Waste Tank Full Sensor" Test Pins 22 to 24 (1 to 4 on Hirschman)	24VAC -Full 0VAC - Not Full	Orange		
	Waste Closed Switch		25	Closed Switch +	3.3VDC	Black		
			26	Closed Switch Ground -		Black		
	Waste Open Switch		27	Open Switch +	3.3VDC	Black		
			28	Open Switch Ground -		Black		
	Filter Pump Relay Contact Signal When Pump Is On		29	Filter Pump On Contact				
			30	Filter Pump On Contact				
	J2		24VDC Power Output from FIB to Far-Right VIB Board (RJ45)	8075810	1	Ground		
					2	Ground		
					3	Ground		
					4	Ground		
5		Power			+24VDC			
6		Power			+24VDC			
7		Power			+24VDC			
8		Power			+24VDC			
J3	C-Bus from Far-Right SIB Board (RJ11)	8075551	1	5VDC	+5VDC			
			2	CAN High				
			3	CAN Low				
			4	Ground				
J4	C-Bus or Network Resistor (pins 2 & 3) (RJ11)	(8075632 resistor)	1	5VDC+	+5VDC			
			2	CAN High				
			3	CAN Low				
			4	Ground				

### 1.11.5 Replacing the FIB Board, Power Supply, or SUI Communication Board

Disconnect the fryer from the electrical power supply. Locate the FIB box (see Figure 17 in section 1.11), behind the oil reservoir). Remove the cover of the FIB box to expose the power supply, FIB board and optional SUI communication board (see Figure 21). Mark and unplug any wires or harnesses. Replace the defective component and reattach all wires or harnesses. Replace the cover. Once replaced, **CYCLE POWER TO ENTIRE FRYER SYSTEM**. See section 1.13 to cycle control power. Check software version and if necessary update the software. If a software update is necessary, follow the instructions to update the software in section 1.15.

Press the information (?) button; press the down arrow; press the SW version button to verify software version of the FIB. If the FIB software version is not visible, the FIB may not be connected properly.

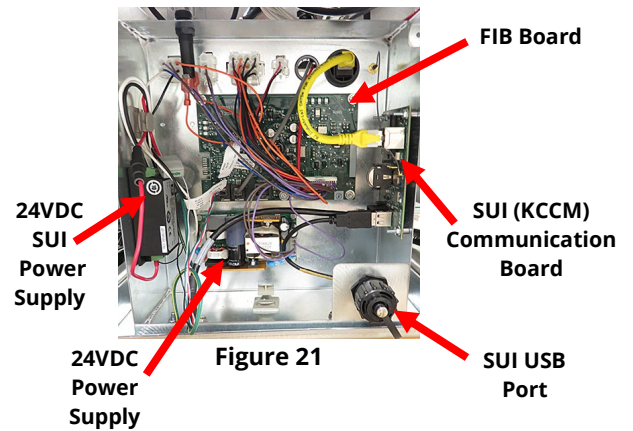

### 1.11.6 Replacing the ATO Pump or Solenoid

Disconnect the fryer from the electrical power supply. Locate the ATO pump (see Figure 22), behind the ATO box. Mark and unplug any wires or harnesses. Press down from the top on the quick disconnects to release the plumbing (see Figure 23). The plumbing can be pulled from the pump. Loosen the four nuts attaching the pump to the pump tray. Disconnect the electrical connection. Replace the defective component and reverse above steps. Once replaced, reconnect the power.



Figure 22

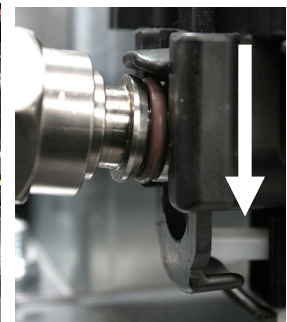

Figure 23

### 1.11.7 Replacing the ATO or VIB (AIF) Probe

1. Disconnect the fryer from the electrical power supply and reposition it to gain access to the rear of the fryer.
2. Remove the associated side panel, if replacing an outside probe, to gain access to probe harness.
3. Drain cooking oil below the level of the probe to be replaced.
4. Disconnect the component wires as follows:
  - a. If replacing the ATO probe, disconnect them from SIB board.
  - b. If replacing the VIB (AIF) probe, use a paperclip to push pins from the J1 connector on the VIB board.
5. Unscrew the probe from the frypot.
6. Apply Loctite® PST56765 pipe thread sealant or equivalent to the replacement part threads and screw the replacement part into the frypot. If replacing an ATO or VIB probe **ensure the probe is flush with the side of the vat** prior to tightening. Torque the component to 180 inch-pounds.
7. Reverse steps 1 through 5 to complete the procedure.



Figure 24

## 1.12 VIB (Valve Interface Board) Service Procedures

The VIB (Valve Interface Board) controls the actuators that open and close the drain and return valves. The VIB boards are located inside a protective housing under each frypot (see Figure 25).



Figure 25

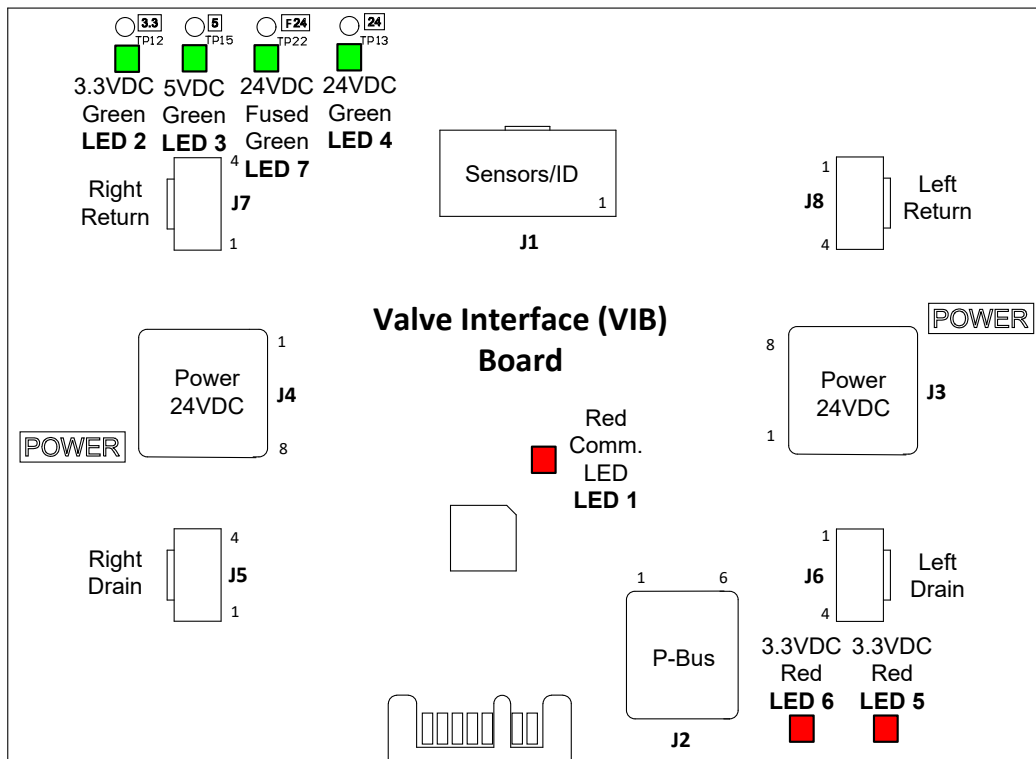

Figure 26

### 1.12.1 VIB (Valve Interface Board) Troubleshooting

**NOTE: DO NOT CHECK WITH HARNESSES UNPLUGGED AS SHORTING THE PINS MAY OCCUR WHICH WILL DAMAGE THE BOARD.**

Problem	Probable Causes	Corrective Action
<p><b>Actuator doesn't function.</b></p>	<p>A. No power to the VIB board.            B. Actuator is unplugged.            C. VIB/FIB board failure.            D. Actuator voltage is incorrect.            E. Actuator is defective.</p>	<p>A. Check pins 4 and 5 of J2 at the FIB board. Should read 24VDC. Check voltage on pins 4 and 5 at the other end of harness and ensure 24VDC is present. Continue to check pins 4 and 5 for 24VDC on plugs J3 and J4 on the VIB boards.</p> <p>B. Ensure the actuator is plugged into the proper connection (J7 for FV or Right DV return, J8 for Left DV return and J5 for FV or Right DV drain and J6 for Left DV drain).</p> <p>C. Check the DC voltage with the actuator plugged in on the connector of the problem actuator while trying to manually open or close an actuator. <b><u>DO NOT CHECK WITH ACTUATOR UNPLUGGED, AS SHORTING THE PINS MAY OCCUR, WHICH WILL DAMAGE THE BOARD.</u></b> Pins 1 (Black) and 4 (White) should read +24VDC when the actuator is opening. Pins 2 (Red) and 4 (White) should measure -24VDC when the actuator is closing). If either voltage is missing, the VIB board or FIB board is likely bad. Test the actuator by plugging into another connector. If the actuator operates, replace the VIB board.</p> <p>D. Check the DC voltage with the actuator plugged in between pin 3 (blue wire) and pin 4 (white wire). <b><u>DO NOT CHECK WITH ACTUATOR UNPLUGGED, AS SHORTING THE PINS MAY OCCUR, WHICH WILL DAMAGE THE BOARD.</u></b> Closed = below 0.825VDC and above 4mv. Open = Below 2.475V and above 0.825VDC. The voltage is out of tolerance and will have failure status if values are above 2.475VDC or less than 4mv.</p> <p>E. If proper voltages are present at the connector and actuator doesn't operate reset power to the fryer. If it still doesn't operate, replace the actuator.</p>

Problem	Probable Causes	Corrective Action
Actuator functions on wrong vat or wrong valve.	A. Actuator plugged into wrong connector.	A. Ensure the actuator is plugged into correct connection (J7 for FV or Right DV return, J8 for Left DV return and J5 for FV or Right DV drain and J6 for Left DV drain).

### 1.12.2 VIB (Valve Interface Board) Actuator Board Pin Positions and Harnesses

**NOTE: DO NOT CHECK WITH HARNESSES UNPLUGGED AS SHORTING THE PINS MAY OCCUR WHICH WILL DAMAGE THE BOARD.**

Connector	From/To	Harness PN	Pin #	Function	Voltage	Wire Color
J1	VIB (AIF) Probes	1087136 Full VIB 1087137 Split VIB  8263287 VIB (AIF) Probe Only	1	Right VIB Probe Ground	Ohm	Yellow
			2	Right VIB Probe		Red
			3	Left VIB Probe Ground		Yellow
			4	Left VIB Probe		Red
			5			
			6			
			7			
			8			
			9			
			10			
			11			
			12			
			13	Ground		
			14	24VDC +		24VDC
J2	P-Bus Power Communication from SIB (RJ11)	8075555	1	Ground		
			2	P-BUS power	+5VDC	
			3	Modbus RS485 B		
			4	Modbus RS485 A		
			5	Signal ground		
			6	P-BUS power	+12VDC	
J3	24VDC Power Input between VIB Boards (RJ45)	8075810	1	Ground		
			2	Ground		
			3	Ground		
			4	Ground		
			5	Power	+24VDC	
			6	Power	+24VDC	
			7	Power	+24VDC	
			8	Power	+24VDC	
J4	24VDC Power Output between VIB Boards (RJ45)	8075810	1	Ground		
			2	Ground		
			3	Ground		
			4	Ground		
			5	Power	+24VDC	
			6	Power	+24VDC	
			7	Power	+24VDC	
			8	Power	+24VDC	
J5	FV (Right) Drain		1	Drain + (Open)	+24VDC	Black
			2	Drain - (Closed)	-24VDC	Red
			3	Drain Position		Blue
			4	Ground		White
J6	DV (Left) Drain		1	Drain + (Open)	+24VDC	Black
			2	Drain - (Closed)	-24VDC	Red
			3	Drain Position		Blue
			4	Ground		White
J7	FV (Right) Return		1	Ret + (Open)	+24VDC	Black
			2	Ret - (Closed)	-24VDC	Red
			3	Ret Position		Blue

			4	Ground		White
J8	DV (Left) Return		1	Ret + (Open)	+24VDC	Black
			2	Ret - (Closed)	-24VDC	Red
			3	Ret Position		Blue
			4	Ground		White

### 1.12.3 Replacing a VIB (Valve Interface Board)

Disconnect the fryer from the electrical power supply. Locate the VIB (valve interface board) to be replaced under a frypot. Mark and unplug the harnesses. The VIB assembly is held in place with one screw (see Figure 27). Remove the screw and the assembly drops down (see Figure 28) and the tab slides out of the bracket attached to the frypot (see Figure 29). Reverse steps to reassemble, ensuring that the new VIB assembly slides into the slot in the bracket. Once complete, **CYCLE POWER TO ENTIRE FRYER SYSTEM**. See section 1.13 to cycle control power. Check software version number and if necessary update the software. If a software update is necessary, follow the instructions to update the software in section 1.15.

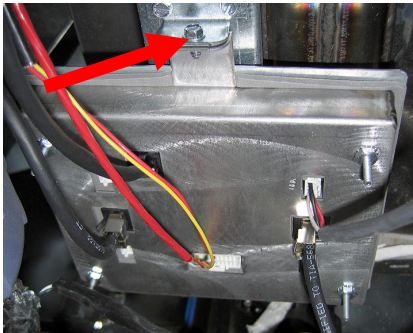

Figure 27

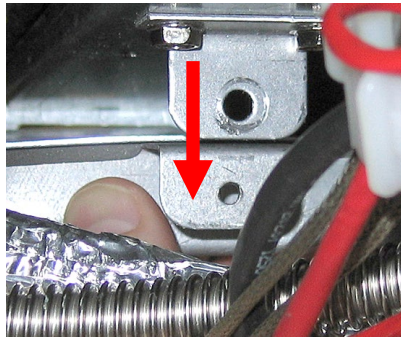

Figure 28

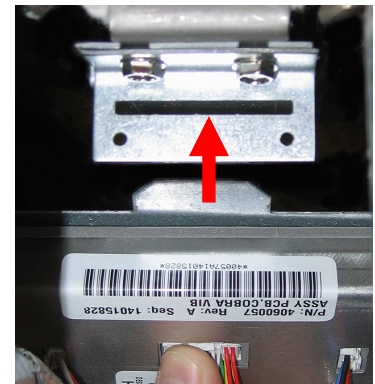

Figure 29

### 1.12.4 Replacing a Rotary Actuator

Disconnect the fryer from the electrical power supply. Locate the actuator to be replaced and mark and unplug the actuator. The actuators are held in place by two Allen screws (see Figure 30). Loosen the Allen screws. Remove the actuator from the valve stem. Align the actuator with the valve stem and attach the new actuator. Tighten the two Allen screws ensuring they are not overtightened, which can strip out the housing. Reconnect power and test the actuator.

**NOTE:** Rotary actuators have two different part numbers which are also color coded (blue and black), which are mirror images of each other that corresponds to their mounting position.

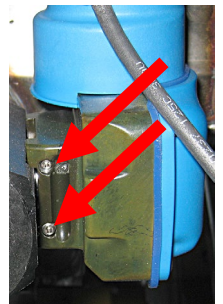

Figure 30

### 1.13 Control Power Switch

The control power switch is a rocker switch, located on the front of the left control box above the USB port (see Figure 31), that controls all power to all the controllers and boards in the fryer. It is necessary to power cycle all power after replacing any controller or board and after any setup change. Turn off the switch for **thirty (30) seconds** when cycling the control power to ensure power has sufficiently drained from boards.

### 1.14 Leakage

Leakage of the frypot will usually be due to improperly sealed high-limit thermostats, RTD's, and drain/return fittings. When installed or replaced, each of these components must be sealed with Loctite® PST56765 sealant or equivalent to prevent leakage. In very rare cases, a leak may develop along one of the welded edges of the frypot. When this occurs, the frypot must be replaced.

If the sides or ends of the frypot are coated with oil, the most probable cause is spillage over the top of the frypot rather than leakage.



Figure 31

The clamps on the rubber boots that hold the drain tube sections together may loosen over time as the tubes expand and contract with heating and cooling during use. Also, the boot itself may be damaged. If the section of drain tube connected to the drain valve is removed for any reason, ensure that its rubber and clamps are in good condition and properly fitted around the drain tube when it is reinstalled. Also, check to ensure that the drain tube runs downward from the drain along its entire length and has no low points where oil may accumulate.

## 1.15 Loading and Updating Software Procedures

Updating the software takes approximately 30 minutes. The software only needs to be loaded in the USB port in the far-left fryer cabinet and it will update **ALL** the controllers and boards in the system. To update the software, follow these steps carefully:

- **The software update may lose the location of product icon on the front screen after the update. Take either a picture/notation of the product locations on the 12 lanes for each vat to ensure they can be loaded back at the end of the update.**
- **Check with the manager about any LTO's (Limited Time Offer) products that may have been programmed into the controllers. If so, capture the product details such as product name, cook time, etc. to program in later.**

**The following reset MUST be performed to clear items before updating.**

1. Power cycle the fryer control power using the reset switch. In most FQG30-T models, this is located under the USB slot (see Figure 3). In some older FQG30-T models, the momentary rocker switch (see Figure 4) is located under the far-left control box (see Figure 5). If the switch is not accessible, unplug the fryer or turn off the breaker to the fryer. **ENSURE THE SWITCH IS PRESSED AND HELD FOR 30 SECONDS.**
2. With the vats **OFF**, remove the jug of oil from under the fryer and manually top off the vats to the upper oil level line prior to starting the update.
3. Pull the filter pan slightly out of the fryer until "P" is visible in the top right corner of the displays.
4. On the **FAR-LEFT** controller press the HOME button.
5. Press the SERVICE button.
6. Press the SERVICE button again.
7. Enter 3000.
8. Press the check button.
9. Press the down arrow button.
10. Press the FIB-RESET 2 button.
11. Press YES to confirm.
12. RESET COMPLETED SUCCESSFULLY is displayed once the reset is complete. If a CAN COMMUNICATION FAILED error occurs see Troubleshooting in section 1.15.1.3.
13. Press the check button.
14. Press the home button.

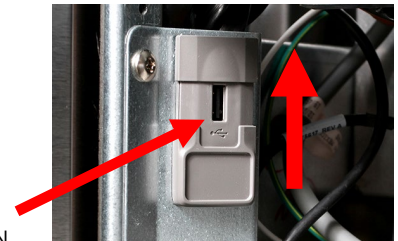

Figure 1



Figure 2



Figure 3

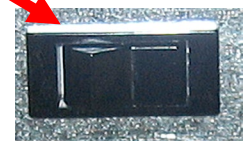

Figure 4

**To update the software, follow these steps carefully:**

1. Switch **ALL** controllers to **OFF**. Press the home button then the information (?) button; press the down arrow; press the SW version button. The controller displays INTIALIZING. Write down the current (UIB, SIB, VIB and FIB) software versions.
2. On the **FAR-LEFT** controller press the HOME button.
3. Press the SERVICE button.
4. Press the SERVICE button again.
5. Enter 3000 for and press the checkmark button.
6. Press the TECH MODES button.
7. Press the down arrow.
8. Press the SOFTWARE UPGRADE button.
9. Controller displays INSERT USB.
10. Open the far-left cabinet door and slide the USB cover up (see Figure 1).
11. Insert the USB flash drive (see Figure 2).
12. The controller displays IS USB INSERTED? YES NO
13. Press the YES button after the USB flash drive is inserted.
14. Controller displays READING FILE FROM USB. PLEASE DO NOT REMOVE USB WHILE READING.
15. Controller displays READING COMPLETED, PLEASE REMOVE USB.
16. Remove the USB flash drive and lower cover over the USB slot.
17. Press the YES button after the USB flash drive is removed.
18. Controller displays CONFIRM CONTROLLERS AVAILABLE FOR UPGRADE UIB, SIB, VIB AND FIB.
19. Press the YES button to continue.
20. Controller displays UIB/SIB/VIB/FIB – DATA TRANSFER IN PROGRESS, WILL COMPLETE IN X MINUTES for each board.
21. Controller displays UIB/SIB/VIB/FIB – UPGRADE IN PROGRESS, WILL COMPLETE IN X MINUTES for each board.
22. When the software update is complete, the controller will display UPGRADE COMPLETE? YES on **the far LEFT controller**.
23. Press the YES button.

24. The controller displays UPGRADE COMPLETED, POWER CYCLE THE SYSTEM.
25. Cycle the fryer control power using the reset switch. In most FQE30-T models, this is located on the front of the far left control box slot (see Figure 3). If the switch is not accessible, unplug the fryer or turn off the breaker to the fryer. **ENSURE THE SWITCH IS PRESSED AND HELD FOR 30 SECONDS.** Failure to press and hold the reset switch long enough, may cause an incomplete software update.
26. While the fryer is rebooting some controllers may take a while to completely reboot as the software is loading.
27. Once all controllers have returned to the (OFF) power standby switch state. **DO NOT POWER ON! Powering on the fryer, prior to loading the MENU's, may disable the fryer!**
28. **VERIFY** software update by pressing the home button; press the information (?) button; press the down arrow; press the Software Version button. The controller displays INTIALIZING. Ensure that the software versions have updated to the correct versions.
29. If software versions match on **ALL** screens, press the home button and proceed to Step 31.
30. If software versions **DO NOT** match, press the home button and return to Step 1.
31. Press the home button. - Press the CREW MODE button.
32. The software update is complete.
33. The menu file(s) **MUST** be updated with this software update. Follow the steps in the next section(s) to update the menu file.

### 1.15.1 Updating Menu Files

**Follow the steps in section 1.15.1.1 to update menus for Taco Bell. For General Market (Non-Taco Bell) use the instructions in section 1.15.1.2 to update the menus.**

#### 1.15.1.1 Taco Bell Menu Update Instructions

**NOTE: This will overwrite any current product menu items and their settings. This may require re-entering any limited time offering products cook times, temperatures, etc. and reassigning products to their locations on the touch screen controller.**

1. Switch all controllers to **OFF**.
2. On the **FAR-LEFT** controller press the HOME button.
3. Press the SERVICE button.
4. Press the MANAGER button.
5. Enter 1656.
6. Press the check button.
7. Press the USB – MENU OPERATION button.
8. Press the COPY MENU FROM USB TO FRYER button.
9. The controller displays INSERT USB.
10. Open the far-left cabinet door and slide the USB cover up (see Figure 1).
11. Insert the USB flash drive (see Figure 2).
12. The controller displays IS USB INSERTED? YES NO
13. Press the YES button after the USB flash drive is inserted.
14. Controller displays READING FILE FROM USB. PLEASE DO NOT REMOVE USB WHILE READING.
15. Controller displays UI – UI DATA TRANSFER IN PROGRESS changing to MENU UPGRADE IN PROCESS.
16. Controller displays UPGRADE COMPLETE?
17. Press YES
18. Controller displays MENU UPGRADE COMPLETED, REMOVE THE USB AND RESTART THE ENTIRE BATTERY.
19. Remove the USB flash drive and lower cover over the USB slot.
20. Press the YES button after the USB flash drive is removed.
21. Cycle the fryer control power using the reset switch. In most FQG30-T models, this is located under the USB slot (see Figure 3). In some older FQG30-T models, the momentary rocker switch (see Figure 4) is located under the far-left control box (see Figure 5). If the switch is not accessible, unplug the fryer or turn off the breaker to the fryer. **ENSURE THE SWITCH IS PRESSED AND HELD FOR 30 SECONDS.**
22. Push the filter pan back into the fryer until a “P” in **NOT** visible on the top right corner of the display.
23. Products may need reassigned to their locations and any limited time offer (LTO's) products may need to be reprogrammed into each controller, as they may have been overwritten during the update.

### 1.15.1.2 General Market Menu (Non-Taco Bell) Update Instructions

**NOTE: This will overwrite any current product menu items and their settings. This may require re-entering any limited time offering products cook times, temperatures, etc. and reassigning products to their locations on the touch screen controller.**

1. Switch all controllers to **OFF**.
2. On the **FAR-LEFT** controller press the HOME button.
3. Press the SERVICE button.
4. Press the MANAGER button.
5. Enter 1656.
6. Press the check button.
7. Press the USB – MENU OPERATION button.
8. Press the COPY MENU FROM USB TO FRYER button.
9. The controller displays INSERT USB.
10. Open the far-left cabinet door and slide the USB cover up (see Figure 1).
11. Insert the USB flash drive (see Figure 2).
12. The controller displays IS USB INSERTED? YES NO
13. Press the YES button after the USB flash drive is inserted.
14. Controller displays READING FILE FROM USB. PLEASE DO NOT REMOVE USB WHILE READING.
15. Controller displays menu file(s) on the USB drive with .cbr suffix(es).
16. Press the desired menu file to load.
17. Controller displays SELECT VATS FOR MENU UPGRADE.
18. Press each vat to load the desired menu. If file is to load to ALL vats press each number (Example: In a 3-vat system, press 1, 2 and 3.
19. Press the check button.
20. Controller displays UI – UI DATA TRANSFER IN PROGRESS changing to MENU UPGRADE IN PROCESS.
21. Controller displays UPGRADE COMPLETE?
22. Press YES on each controller.
23. Controller displays MENU UPGRADE COMPLETED, REMOVE THE USB AND RESTART THE ENTIRE BATTERY.
24. Remove the USB flash drive and lower cover over the USB slot.
25. Cycle the fryer control power using the reset switch. In most FQG30-T models, this is located under the USB slot (see Figure 3). In some older FQG30-T models, the momentary rocker switch (see Figure 4) is located under the far-left control box (see Figure 5). If the switch is not accessible, unplug the fryer or turn off the breaker to the fryer. **ENSURE THE SWITCH IS PRESSED AND HELD FOR 30 SECONDS.**
24. Push the filter pan back into the fryer until a “P” in **NOT** visible on the top right corner of the display.
25. Products may need reassigned to their locations and any limited time offer (LTO's) products may need to be reprogrammed into each controller, as they may have been overwritten during the update.

### 1.15.1.3 Software/Menu Update Troubleshooting

#### **CAN COMMUNICATION FAILED or CAN communication error during an update**

1. Power cycle fryer ensuring that the reset switch is pressed and held for **60 seconds** or greater or power is removed for **60 seconds** or greater.
2. Update the software or menus again.
3. Check software versions or menus. If they still do not update repeat step #1 and recheck.

#### **Software or menus do not update**

1. Power cycle fryer ensuring that the reset switch is pressed and held for **60 seconds** or greater or power is removed for **60 seconds** or greater.
2. Recheck software versions or menus. If they still do not update repeat step #1 and recheck.

#### **Product Icons/Photos missing**

1. Update the menu files again.
2. Power cycle fryer ensuring that the reset switch is pressed and held for **60 seconds** or greater or power is removed for **60 seconds** or greater.
3. Recheck software versions or menus. If they still do not update repeat step #1 and recheck.



### Display reboots automatically during an update

1. Power cycle fryer ensuring that the reset switch is pressed and held for **60 seconds** or greater or power is removed for **60 seconds** or greater.
2. Update the software or menus again.
3. Check software versions or menus. If they still do not update repeat step #1 and recheck.

### Controller keeps rebooting after an update

1. Ensure **ALL** controllers display **OFF**.
2. Update the menu files again.
3. Power cycle fryer ensuring that the reset switch is pressed and held for **60 seconds** or greater or power is removed for **60 seconds** or greater.
4. Check menus. If they still do not update repeat step #1 and recheck.

### Change Filter message after an FIB2 Reset

1. This is normal after an FIB2 reset.
2. Pull the filter pan slightly out of the cabinet until a "P" is visible on the top right corner of the display for **60 seconds** or greater until the message clears.
3. Push the filter pan back into the fryer.

### Controller displays SPIFI FILE ERROR and SD CARD FILE ERROR

1. Flash drive not removed when prompted during software update. Remove the USB, power cycle the fryer, ensuring the power is removed for **60 seconds** or greater.

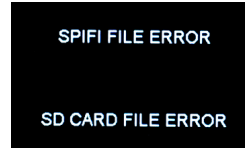

### Controller displays NO SPIFI CRC AVAILABLE, SD CARD FILE ERROR, USB FILE ERROR

1. Power cycle the fryer, ensuring the power is removed for **60 seconds** or greater.
2. If the controller doesn't recover, the memory is corrupted. In some instances, the controller may be recovered, call 1-800-551-8633.
3. If the controller can't be recovered, replace the controller.

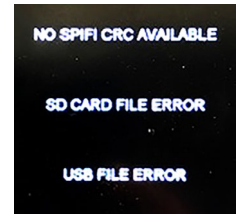

### Software upgrade not available (grayed out).

1. Ensure the software upgrade is performed on the far-left controller.
2. Ensure all vats are soft powered OFF.
3. Controller vat ID locators are incorrect.
4. Check BOARD ID numbers in Software Version view of controller. Board ID = 1 on far-left controller, Board ID=2 on the next vat to the right, etc. If any are incorrect Board ID #'s check locator that is plugged in to the rear of the controller for proper pin position.

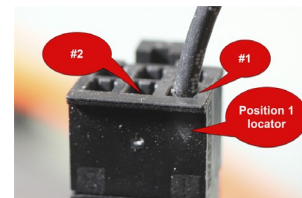
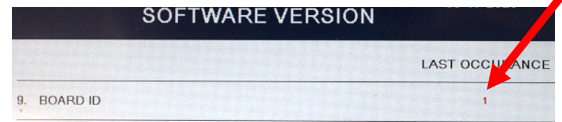
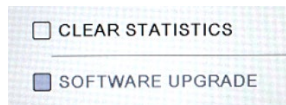

### Controller display doesn't return after an update. Screen stays black for longer than 5 minutes.

1. Power cycle the fryer, ensuring the power is removed for **60 seconds** or greater.
2. If the controller doesn't recover, the memory is corrupted. Replace the controller.

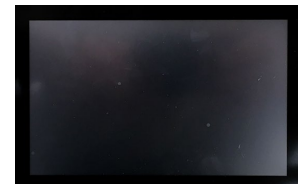

### E81 - SAFE MODE FAILURE, TECHNICAL SUPPORT REQUIRED - Prompting for a password.

1. Fill the frypot with oil to top level line.
2. Press on text **ENTER PASSWORD** inside the box.
3. Enter **4 3 5 7** and press [?].
4. Press the [?] button again.
5. The fryer is **OFF**.
6. Turn the fryer on and let it heat normally.

## 1.16 Replacing Fryer Components

### 1.16.1 Replacing Contactor Box Components

1. Disconnect the fryer from the electrical power supply.
2. Relocate the fryer if necessary.
3. If replacing the hood relay remove the left side of the fryer.
4. Locate the contactor box.
5. Remove the two screws securing the cover of the contactor box cover from the contactor box (see Figure 35).
6. Remove the cover to expose the interior of the contactor box (see Figure 36).

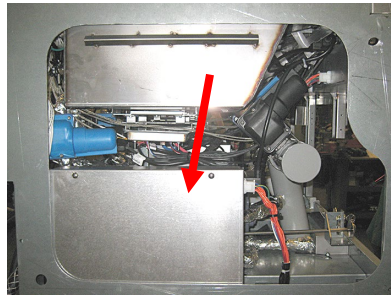

Figure 35

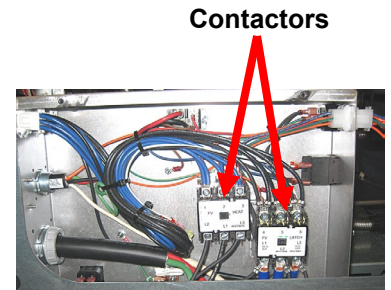

Figure 36

7. The contactors and relays are held on by threaded pin studs so that only removal of the nut is required to replace the component.
8. Replace the component(s) marking the wires to ease reassembly.
9. After performing necessary service, reverse steps to return the fryer to complete installation and return to operation.

### 1.16.2 Replacing a Heating Element

1. Perform steps 1-4 of section 1.8.5, *Replacing the Temperature Probe*.
2. Disconnect the 12-pin connector C-6 wire harness containing the probe wiring, attached to the element that is being replaced. Locate the red, black, (or yellow) and white wires of the temperature probe to be replaced. Note where the leads are connected prior to removing them from the connector.
3. Using a pin pusher, disconnect the probe wires from the 12-pin connector.
4. In the rear of the fryer disconnect the 6-pin connector for the left element (as viewed from the front of the fryer) or the 9-pin connector for the right element attached to the contactor box. Press in on the tabs on each side of the connector while pulling outward on the free end to extend the connector and release the element leads (see Figure 37). Pull the leads out of the connector and out of the wire sleeving.

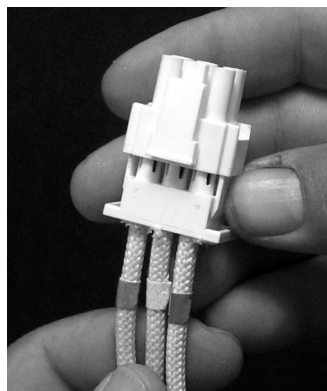
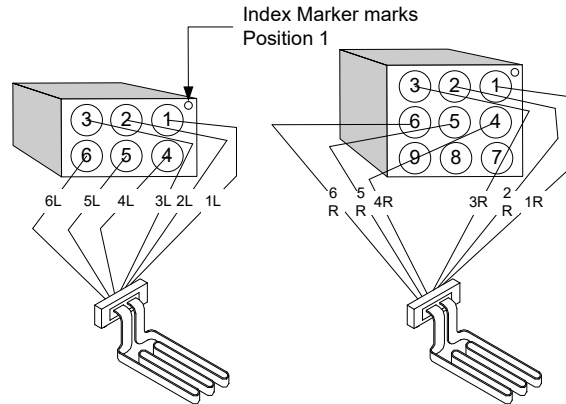

Figure 37

5. Raise the element to the full up position and support the elements.
6. Remove the hex head screws and nuts that secure the element to the tube assembly and pull the element out of the frypot. **NOTE:** The nuts inside the tube can be held and removed using the RE element tube nut spanner, PN# [2304028](#). Full-vat elements consist of two dual-vat elements clamped together. For full-vat units, remove the element clamps before removing the nuts and screws that secure the element to the tube assembly.

7. If applicable, recover the probe bracket and probe from the element being replaced and install them on the replacement element. Install the replacement element in the frypot, securing it with the nuts and screws removed in Step 6 to the tube assembly. Ensure the gasket is between the tube and element assembly.
8. Route the element leads through the element tube assembly and into the wire sleeving to prevent chafing. Ensure that the wire sleeving is routed back through the Heyco bushing, keeping it clear from the lift springs (see photos below). Also ensure that the wire sleeving extends into the tube assembly to protect the edge of the tube assembly from chafing the wires. Press the pins into the connector in accordance with the diagram below, and close the connector to lock the leads in place. **NOTE:** It is critical that the wires be routed through the sleeving to prevent chafing.



**Figure 38**

### Full vat element wire routing

Pull the element wires through the bushings on either side of the frypot and down the back. Element wires should be routed to the right of the ATO temperature probe on the back wall of the frypot.

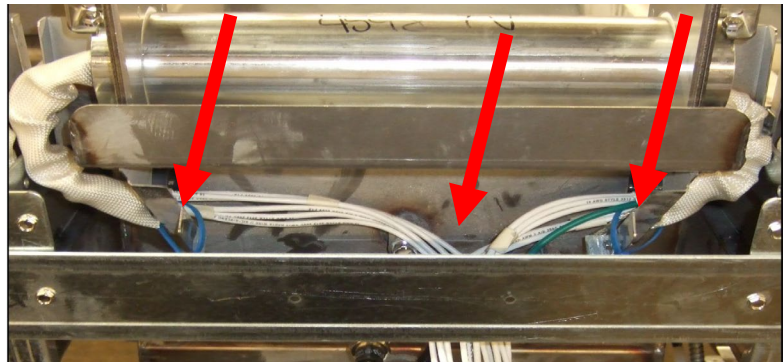

**Figure 39**

### Dual vat element wire routing

Pull the element wires through the bushings on either side of the frypot and down the back. Element wires should be routed to the center of the frypot between the ATO temperature probes.

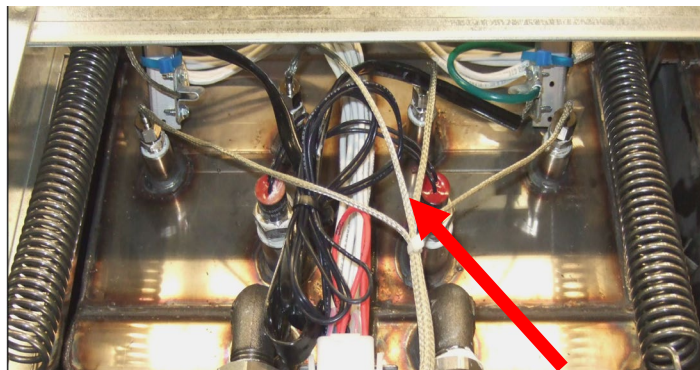

**Figure 40**

## Element grounding and wire routing

To ground the element wires, use the hole in the frypot frame located under the bushing that the element wires pass through. Using a screw through the ground wires ring terminal, connect it to the frypot using the probe ground clip. Use a tie wrap to tie up half of the element wires after the wires are pulled through the bushing. Do not pull tie wrap tight, leave some slack in it about one inch in diameter to allow some movement.

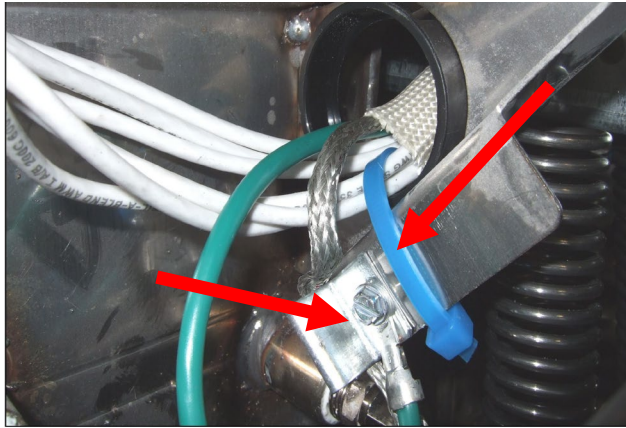

Figure 41

9. Reconnect the element connector ensuring that the latches lock.
10. Insert the temperature probe leads into the 12-pin wiring harness connector (see Figure 42). For full-vat units or the right half of a dual-vat unit, the red lead goes into position 3 and the white into position 4. For the left half of a dual-vat unit, the red lead goes into position 9 and the white into position 10. **NOTE: Right and left** refer to the fryer as viewed from the rear.

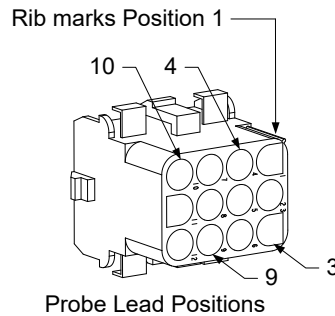

Figure 42

10. Reconnect the 12-pin connector of the wiring harness disconnected in Step 2.
11. Lower the element to the full down position.
12. Reinstall the tilt housing, back panels and contactor plug guard. Reposition the fryer under the exhaust hood, and reconnect it to the electrical power supply.

### 1.16.3 Replacing a Frypot

1. Drain the frypot into the filter pan or, if replacing a frypot over the filter system, into a Shortening Disposal Unit (SDU) or other appropriate **METAL** container. If replacing a frypot over the filter system, remove the filter pan and lid from the unit.



**DO NOT drain more than one full frypot or two split frypots into the SDU at one time.**

2. Disconnect the fryer from the electrical power supply and reposition it to gain access to both the front and rear.
3. Remove the two screws from the upper corners of the controller. Lift up to clear the screen guards and allow the controller to swing down.
4. Unplug the wiring harnesses and ground wires from the backs of the controllers.
5. Disconnect the lanyard and remove the controller.
6. Remove the bezel by removing the left screw and loosening the right screw on the bottom of the bezel.
7. Disconnect the cables attached to the components marking or making a note of the connectors to facilitate reconnection.

8. Remove the tilt housing and back panels from the fryer. The tilt housing must be removed first to remove the upper back panel.
9. To remove the tilt housing, remove the hex-head screws from the rear edge of the housing. The housing can be lifted straight up and off the fryer.
10. Remove the control panel by removing the screw in the center and the nuts on both sides.
11. Loosen the component boxes by removing the screws, which secure them in the cabinet.
12. Dismount the top cap by removing the nuts at each end that secure it to the cabinetry.
13. Remove the hex head screw that secures the front of the frypot to the cabinet cross brace.
14. Remove the top-connecting strip that covers the joint with the adjacent frypot.
15. Unscrew the nut located on the front of each section of drain tube, and remove the tube assembly from the fryer.
16. Remove the actuators from the drain and return valves and disconnect the wiring.
17. Disconnect any auto filtration probes and auto top off sensors and wiring.
18. At the rear of the fryer, unplug the 12-pin connector C-6 and, using a pin pusher, disconnect the high-limit thermostat leads. Disconnect any other probe wiring.
19. Disconnect the oil return flexline(s).
20. Raise the elements to the "up" position and disconnect the element springs.
21. Remove the machine screws and nuts that secure the element tube assembly to the frypot. Carefully lift the element assembly from the frypot and secure it to the cross brace on the rear of the fryer with wire ties or tape.
22. Carefully lift the frypot from the fryer and place it upside down on a stable work surface.
23. Recover the drain valve(s), oil return flexline connection fitting(s), actuators, VIB (AIF) boards and high-limit thermostat(s) from the frypot. Clean the threads and apply Loctite™ PST 567 or equivalent sealant to the threads of the recovered parts and install them in the replacement frypot.
24. Carefully lower the replacement frypot into the fryer. Reinstall the hex head screw removed in step 11 to attach the frypot to the fryer.
25. Position the element tube assembly in the frypot and reinstall the machine screws and nuts removed in step 19.
26. Reconnect the oil return flexlines to the frypot, and replace aluminum tape, if necessary, to secure heater strips to the flexlines.
27. Insert the high-limit thermostat leads disconnected in step 18 (see illustration on page 1-14 for pin positions).
28. Reconnect the actuators, ensuring the correct position of the drain and return valves.
29. Reconnect the auto filtration and auto top off probes.
30. Reinstall the drain tube assembly.
31. Reinstall the top connecting strips, top cap, tilt housing and back panels.
32. Reinstall controllers in the control panel frame and reconnect the wiring harnesses and ground wires.
33. Reposition the fryer under the exhaust hood and reconnect it to the electrical power supply.

## **1.17 Wiring Diagrams**

**See 8197464 FQE30-T Electric Wiring Diagrams Manual**

# FQE30-T FILTERQUICK™ ELECTRIC FRYERS

## Appendix A: Bulk Oil Service Issues

---

### A.1 Bulk FIB Tests

These instructions may **NOT** be applicable to all bulk oil systems.

The FilterQuick-T™ fryer will **ONLY** operate with a three-pole float switch for waste oil to determine if the tank is full. If a two-pole switch is used it may cause damage to the FIB board. The float switches are polarity specific which may short to ground and damage an FIB board.

**AC voltage measurements from the bulk oil connector on rear of fryer:**

Pin 1 to Pin 2 - 24 VAC.

Pin 1 to Pin 4 - 24 VAC when waste tank is full, 0 VAC when it is not full.

Pin 1 to Pin 3 - 24 VAC when bulk fresh oil add switch and pump is on, 0 VAC when it is off.

### Troubleshooting

All return and drain valves should be closed and pump should be off while the FIB is resetting. If any of the valves or the pump is on during reset, the FIB board is bad or wires are shorted.

**Bulk fresh oil pump is not operating or Oil Reservoir is not filling:**

**NOTE: DO NOT CHECK PINS WITH HARNESES UNPLUGGED AS SHORTING THE PINS MAY OCCUR WHICH WILL DAMAGE THE BOARD.**

**Normal measurements (FIB C7 12-pin or rear of FIB box (J1 30-pin) connector with everything connected)**

See page A-4 to ensure that no other function is taking priority over adding oil to jug.

1. Reset the power; wait **60 seconds** and see if the valve opens.

**With the Orange JIB (Oil Reservoir) button pressed:**

2. Voltage at FIB board C7 from Pin 5 to Pin 6 (FIB board J1 from Pin 21 to Pin 22) should be 24 VAC; if not, check connections from bulk fresh oil 24VAC transformer and check transformer.

3. Voltage at FIB board C7 from Pin 6 to Pin 7 (FIB board J1 from Pin 21 to Pin 23) should be 24 VAC when filling JIB or vat; if not, the FIB board is bad or wires to pump relay are shorted or both.

4. Voltage at Fresh Add Pump Relay should be 24 VAC; if not, check wiring from FIB board. The relay is located on top of some fresh oil bulk systems.

**Waste full signal:**

Voltage at FIB board C7 Pin 5 to Pin 8 (FIB board J1 from Pin 22 to Pin 24) should be 24 VAC when full, 0 VAC when not full; if no voltage level change, the connection from bulk waste full switch or FIB board is bad.

## A.2 Bulk Oil Wiring Connection behind Fryer

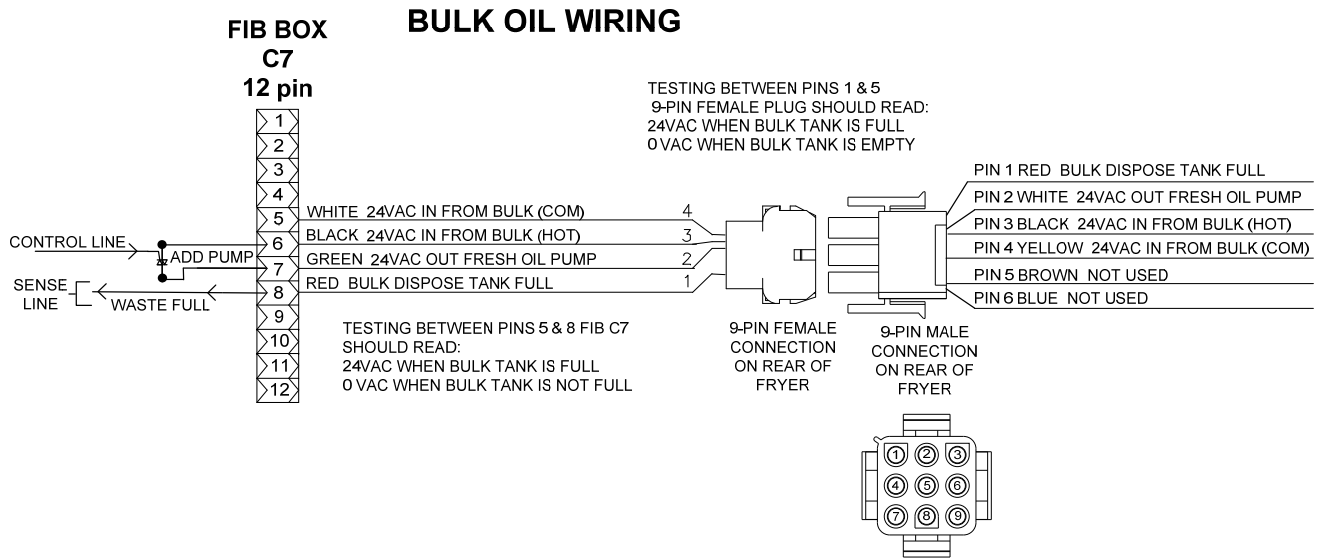

Figure 1

## A.3 Frymaster FilterQuick-T Fryer and Bulk Oil System Plumbing Schematic

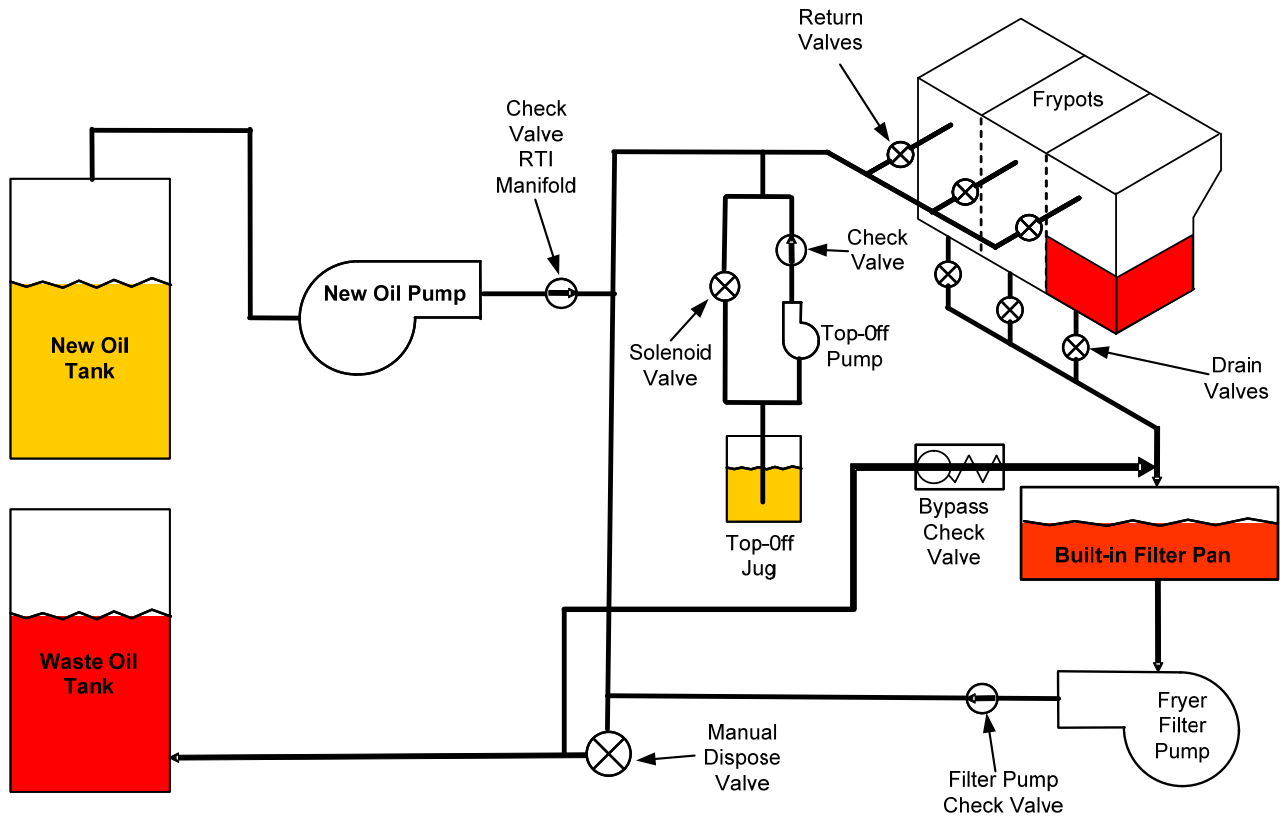

Figure 2

## A.4 Bulk Test Quick Reference

### A.4.1 DISPOSE TO WASTE, REFILL VAT FROM BULK:



1. Press the filter button.
2. Select LEFT VAT or RIGHT VAT for split vats.
3. Select DISPOSE OIL.
4. "DISPOSE OIL? YES/NO" is displayed. \*
5. Press the ✓ (check) button to dispose of oil in vat.
6. "DRAINING IN PROGRESS" is displayed.
7. "VAT EMPTY? YES" is displayed.
8. Once the vat is empty, press the ✓ (check) button.
9. "CLEAN VAT COMPLETE? Yes" is displayed.
10. Press the ✓ (check) button.
11. "OPEN DISPOSE VALVE" is displayed.
12. Open dispose valve.
13. "DISPOSING" is displayed for four minutes.
14. "REMOVE PAN" is displayed.
15. Remove filter pan.
16. "IS PAN EMPTY? YES/NO" is displayed.
17. Press the ✓ (check) button if the filter pan is empty. Select "NO" if oil remains in the filter pan.
18. "INSERT PAN" is displayed.
19. Insert the filter pan.
20. "CLOSE DISPOSE VALVE" is displayed.
21. Close dispose valve.
22. "FILL VAT FROM BULK? YES/NO" is displayed.
23. Press the ✓ (check) button.
24. "START FILLING? PRESS AND HOLD" is displayed.
25. Press and hold the button to fill the vat.
26. RELEASE BUTTON WHEN FULL.
27. Release the button when the vat is full.
28. "Continue Filling Yes/No" is displayed
29. Press the ✓ (check) button to continue filling or press "NO" to exit.

\***NOTE:** If the waste tank is full, the controller displays "BULK TANK FULL? YES". Press the ✓ (check) button and call RTI.

### A.4.2 DISPOSE TO WASTE:



1. Press the filter button.
2. Select LEFT VAT or RIGHT VAT for split vats.
3. Select DISPOSE OIL.
4. "DISPOSE OIL? YES/NO" is displayed. \*
5. Press the ✓ (check) button to dispose of oil in vat.
6. "DRAINING IN PROGRESS" is displayed.
7. "VAT EMPTY? YES" is displayed.
8. Once the vat is empty, press the ✓ (check) button.
9. "CLEAN VAT COMPLETE? Yes" is displayed.
10. Press the ✓ (check) button.
11. "OPEN DISPOSE VALVE" is displayed.
12. Open dispose valve.
13. "DISPOSING" is displayed for four minutes.
14. "REMOVE PAN" is displayed.
15. Remove filter pan.
16. "IS PAN EMPTY? YES/NO" is displayed.
17. Press the ✓ (check) button if the filter pan is empty. Select "NO" if oil remains in the filter pan.

18. "INSERT PAN" is displayed.
19. Insert the filter pan.
20. "CLOSE DISPOSE VALVE" is displayed.
21. Close dispose valve.
22. "FILL VAT FROM BULK? YES/NO" is displayed.
23. Press "NO" if you wish to leave vat empty and exit.

#### A.4.3 FILL VAT FROM BULK:



1. Press the filter button.
2. Select LEFT VAT or RIGHT VAT for split vats.
3. Press the down arrow button.
4. Select FILL VAT FROM BULK.
5. "FILL VAT FROM BULK? YES/NO" is displayed.
6. Press the √ (check) button.
7. "START FILLING? PRESS AND HOLD" is displayed.
8. Press and hold the button to fill the vat.
9. RELEASE BUTTON WHEN FULL.
10. Release the button when the vat is full.
11. "Continue Filling Yes/No" is displayed
12. Press the √ (check) button to continue filling or press "NO" to exit.

#### A.4.4 FILL OIL RESERVOIR FROM BULK: \*

1. When "YELLOW" low oil indicator is illuminated on the controller, and/or TOP OFF OIL EMPTY is displayed, the oil reservoir (top-off container) is empty.
2. To refill reservoir, press and hold the orange reset button above the reservoir until the reservoir is full.
3. Release the button to stop filling.

#### A.5 Troubleshooting Oil Reservoir Filling

**\*NOTE: The reservoir may not fill if any of the following are in progress:**

If **FILTRATION REQUIRED – FILTER NOW? YES/NO**, or **SKIM, DEBRIS FROM VAT – PRESS CONFIRM WHEN COMPLETE** are displayed, the fill reservoir button is disabled until either a filter is complete or until NO is chosen.

**The system also checks these conditions. The following must be met before an oil reservoir fill is allowed:**

- Solenoid closed
- Orange fill button pressed longer than 3 sec.
- FILTRATION REQUIRED – FILTER NOW? YES/NO, or SKIM, DEBRIS FROM VAT – PRESS CONFIRM WHEN COMPLETE cannot be displayed
- System power cycle (all boards – Controllers, SIB, VIB and FIB) after changing setup from JIB to Bulk (use momentary reset). Ensure reset is pressed and held for at least **sixty (60) seconds**.
- No filtration or other filter menu selection can be in process.

**Other factors that may not allow fill reservoir from bulk –**

- Defective solenoid
- Defective orange reset switch
- Bulk oil pump issue
- Bulk oil relay stuck

If using two fryer systems that are both attached to the bulk oil system, they may not be able to fill both units at the same time if they have a bulk fresh oil unit with a single head. Some bulk oil fresh units have dual heads which can fill simultaneously.

# *Frymaster*<sup>®</sup>

FRYMASTER  
8700 LINE AVENUE, SHREVEPORT, LA 71106-6800

800-551-8633  
318-865-1711  
[WWW.FRYMASTER.COM](http://WWW.FRYMASTER.COM)  
EMAIL: [FRYSERVICE@WELBILT.COM](mailto:FRYSERVICE@WELBILT.COM)



Welbilt offers fully-integrated kitchen systems. Welbilt's portfolio of award-winning brands includes Cleveland™, Convotherm®, Crystal Tips®, Dean®, Delfield®, Fabristeel®, Frymaster®, Garland®, Inducs®, Koldtech®, Kolpak®, Lincoln®, McCann's™, Merco®, Merrychef®, Multiplex®, RDI®, SerVend™, SunFire®, U.S. Range™, and WMaxx™. Supported by service brands: FitKitchen®, kitchen systems; and KitchenConnect®, cloud-based open platform.

*Bringing innovation to the table* • [welbilt.com](http://welbilt.com)

©2023 Frymaster LLC. except where explicitly stated otherwise. All rights reserved. Continuing product improvement may necessitate change of specifications without notice.

Part Number FRY\_SM\_8197465 11/2023