

## FilterQuick™ FQE30U easyTouch® Electric Fryer

### Parts Manual

This manual is updated as new information and models are released. Visit our website for the latest manual.



#### FOR YOUR SAFETY

Do Not Store or use gasoline  
or other flammable vapors  
and liquids in the vicinity of  
this or any other appliance.



Part Number: FRY\_P\_8197466 02/2024



WELBILT®

# Table of Contents

## CHAPTER 1: Parts List

1.1	Accessories.....	1-1
1.2	Control Panel Frame Assemblies.....	1-1
1.3	Doors, Sides, Tilt Housings, Top Caps and Casters .....	1-2
1.4	Drain System Components .....	1-3
1.5	Electronics and Electrical Components .....	1-4
1.5.1	Component Boxes and Associated Components .....	1-4
1.5.2	Contactor Boxes .....	1-6
1.5.3	Heating Element Assemblies and Associated Parts .....	1-7
	1.5.3.1 Element Assemblies and Hardware.....	1-7
	1.5.3.2 Element Tube Assemblies.....	1-9
1.5.4	FIB (Filtration Interface Board) Filter and Top Off Box Components .....	1-10
1.5.5	VIB (Valve Interface Board) Components .....	1-11
1.5.6	USB Connector .....	1-11
1.5.7	Wiring .....	1-12
	1.5.7.1 Contactor Box Wiring Assemblies – 12-Pin Dual-Vat C-1.....	1-12
	1.5.7.2 Contactor Box Wiring Assemblies – 12-Pin Full-Vat C-1 .....	1-12
	1.5.7.3 Contactor Box Wiring Assembly – 6-Pin (Left Element).....	1-13
	1.5.7.4 Contactor Box Wiring Assembly – 9-Pin (Right Element).....	1-13
	1.5.7.5 Main Wiring Harnesses .....	1-14
	1.5.7.6 Component Box Wiring Harnesses.....	1-15
1.6	Frypots and Associated Components .....	1-17
1.7	Oil Return Manifolds.....	1-18
1.8	Filtration System Components .....	1-19
1.9	ATO (Auto Top Off) Components.....	1-21
	1.9.1 JIB Cradle, JIB Cap and Pick-Up Assembly and JIB (ATO) Reset Switch .....	1-21
	1.9.2 ATO Pump Assembly.....	1-21
1.10	Shortening Melting Unit .....	1-23
1.11	Bulk Dispose and Fresh Oil .....	1-24
	1.11.1 Bulk Dispose, Fresh Oil Manifold and Accessories.....	1-24
	1.11.2 Bulk Dispose Waste Valve.....	1-26
1.12	Basket Lift Assembly and Associated Parts.....	1-27
	1.12.1 Basket Lift Assembly and Associated Parts – From Sept. 2017 to Jan. 2019.....	1-27
	1.12.2 Basket Lift Assembly and Associated Parts – 480V – After Feb. 2019 ( <i>Modular</i> ) .....	1-29
	1.12.3 Basket Lift Assembly and Associated Parts – 480V – After April 2014 ( <i>Modular</i> ).....	1-31
1.13	Oil Quality Sensor (OQS) and Associated Parts .....	1-33
1.14	Wiring Connectors, Pin Terminals and Power Cords .....	1-34
1.15	FilterQuick™ FQE30-T Series Simplified Wiring .....	1-35

# FQE30U easyTouch® FILTERQUICK™ ELECTRIC FRYERS

## CHAPTER 1: PARTS LIST

### 1.1 Accessories

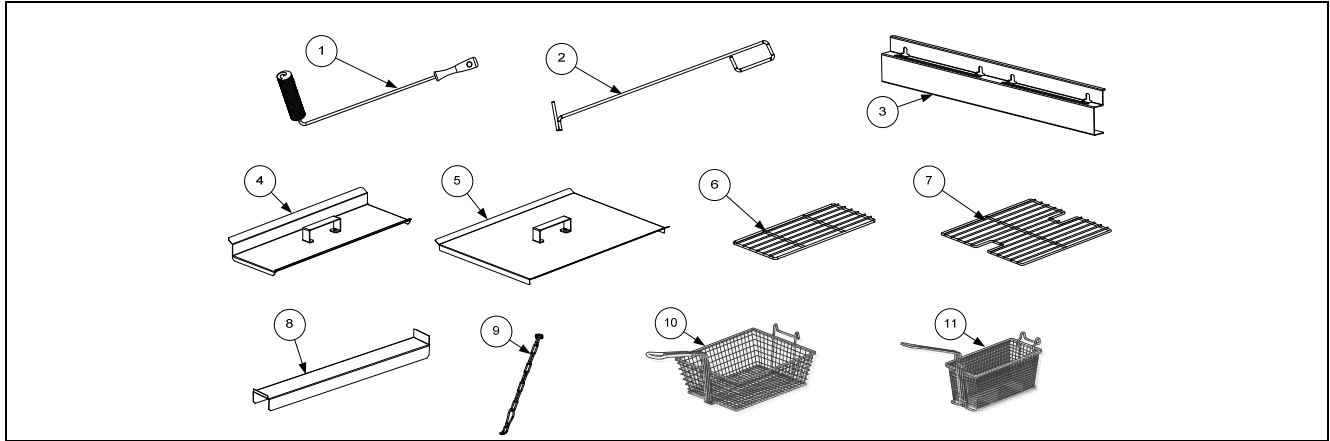

ITEM	PART #	COMPONENT
1	8030278	Brush, Frypot
2	8030388	Fryers Friend
3	2307495	Hanger, Basket Two/Four Station (BK 2309290)
	2307497	Hanger, Basket Three Station (BK 2309292)
4	8238899	Cover, Dual-Vat Frypot
5	8238900	Cover, Full-Vat Frypot
6	8030106	Rack, Dual-Vat Basket Support
7	8030132	Rack, Full-Vat Basket Support
8	1086157	Connecting Strip, Frypot
9	8260900	Kit, Chain Restraint
10	8030099	Basket, Full Size
11	8030271	Basket, Twin Size
*	8030002	Powder, Filter (80- 1-Cup Applications)
*	8030445	Pack, 100-Sheet Filter Paper 16.5 X 25.5

\*Not illustrated.

### 1.2 Control Panel Frame Assemblies

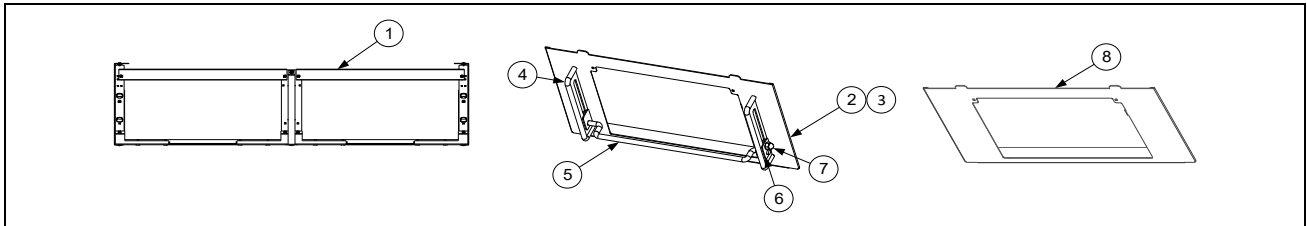

ITEM	PART #	COMPONENT
1	1088340	Frame Assembly, Control 2-Battery 10° <i>(after 12/2018)</i>
	1087710	Frame Assembly, Control 2-Battery <i>(prior to 01/2019)</i>
	1087711	Frame Assembly, Control 3-Battery <i>(prior to 01/2019)</i>
	1088362	Frame Assembly, Control 3-Battery 10° <i>(after 12/2018)</i>
	1087712	Frame Assembly, Control 4-Battery <i>(prior to 01/2019)</i>
	1088359	Frame Assembly, Control 4-Battery 10° <i>(after 12/2018)</i>
	1088360	Frame Assembly, Control 5-Battery 10° <i>(after 12/2018)</i>
2	1087744	Bezel Assembly, Control FQ4000 <i>(prior to 04/2022)</i>
3	2602083	Bezel, Single Touchscreen FQ
4	8104898	Guide, Controller Adjustable Guard
5	8104899	Bar, Guard (Touch Screen Protection)
6	8104714	Plate, Outside Tightening
7	8090047	Nut, Cap ¼-20
8	130000371	Bezel Assembly, Control FQ4000 <i>(after to 03/2022)</i>

### 1.3 Doors, Sides, Tilt Housings, Top Caps and Casters

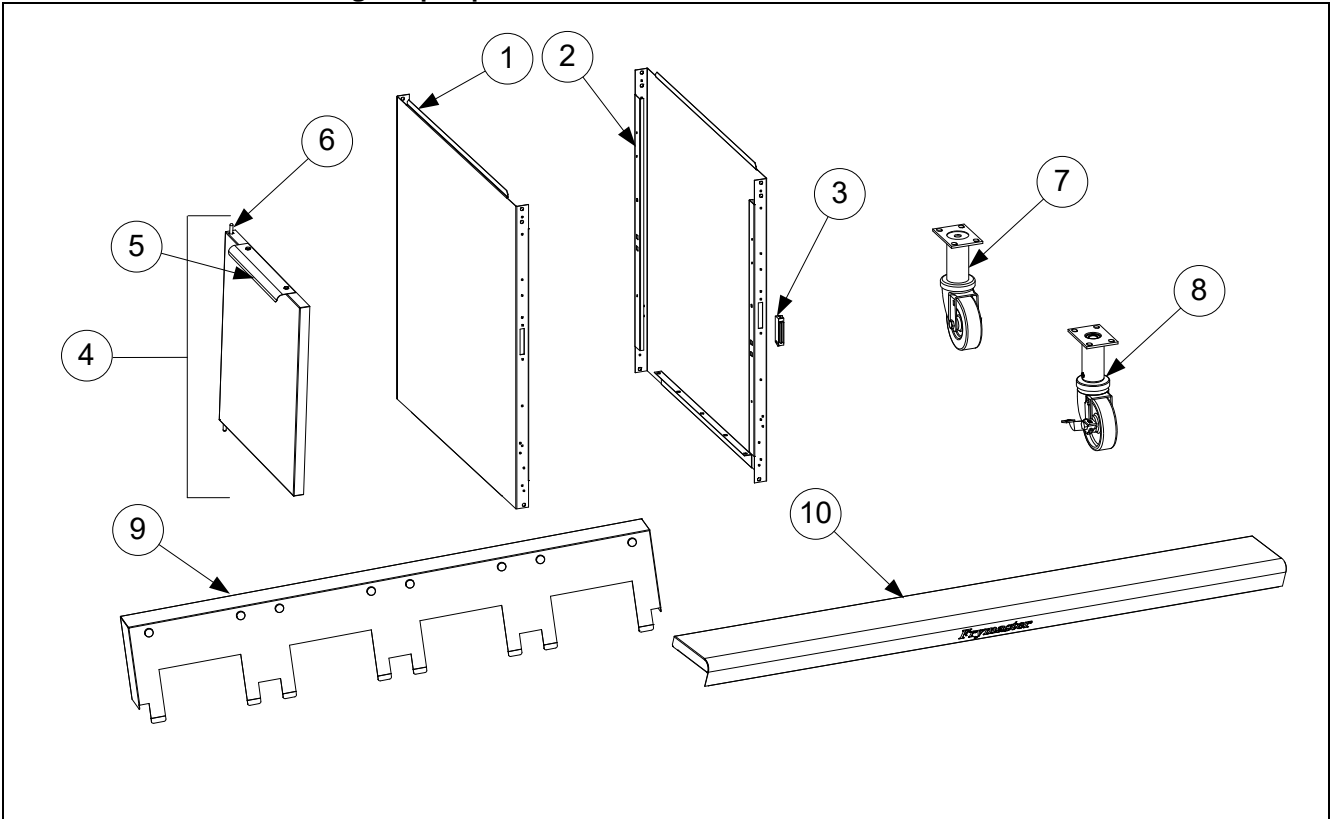

ITEM	PART #	COMPONENT
1	130013734	Side, Cabinet Left <i>(after to 02/2022)</i>
	2310323	Side, Cabinet Left <i>(prior to 03/2022)</i>
2	130013733	Side, Cabinet Right <i>(after to 02/2022)</i>
	2320323	Side, Cabinet Right <i>(prior to 03/2022)</i>
3	8101105	Magnet, Door (vertical) (use 8102346 for horizontal over filter pan)
4	1064397	Door, Left or Right (use 1080825 for door w holder)
5	2304960	Handle, Eurolook Door
6	1064067	Pin Assembly, Door
*	8100275	Spring, Door Pin
*	8090970	Retaining Ring
*	2307192	Hinge, Door Lower
*	2206097	Holder, Manual
7	8100327	Caster 4" without Brake -Rear
8	8100944	Caster 3" with Brake -Front
9		Tilt Housing (Housing for four station fryer shown)
	8237891	Two Station
	8237892	Three Station
	8237893	Four Station
	8237894	Five Station
10		Top Cap
	8239317	Two Station
	8239318	Three Station
	8239319	Four Station
	8239320	Five Station
*	8160971	Gasket, Top cap/Frypot (1 needed per frypot)

\* Not illustrated.

## 1.4 Drain System Components

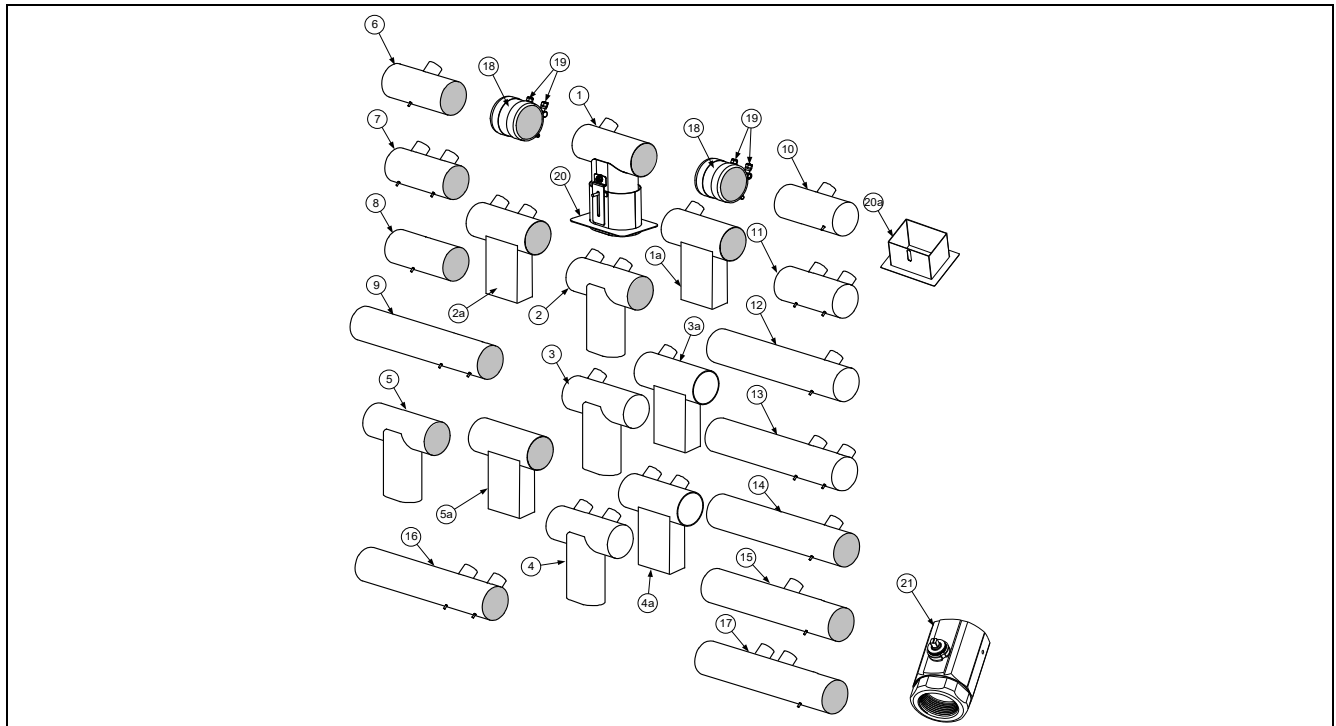

ITEM	PART#	COMPONENT
1	1085806	Drain Tube, Dump Full-Vat Left Closed/Right End Open <b>Oval</b>
1a	130033447	Drain Tube, Dump Full-Vat Left Closed/Right End Open <b>Square</b>
2	1085854	Drain Tube, Dump Dual-Vat Left Closed/Right End Open <b>Oval</b>
2a	130000620	Drain Tube, Dump Dual-Vat Left Closed/Right End Open <b>Square</b>
3	1085836	Drain Tube, Dump Full-Vat Left Closed Both Ends <b>Oval</b>
3a	130000618	Drain Tube, Dump Full-Vat Left Closed Both Ends <b>Square</b>
4	1085856	Drain Tube, Dump Dual-Vat Left Closed Both Ends <b>Oval</b>
4a	130000622	Drain Tube, Dump Dual-Vat Left Closed Both Ends <b>Square</b>
5	1085842	Drain Tube, Dump Full-Vat Left Closed/Right End Open <b>Oval</b>
5a	130000624	Drain Tube, Dump Full-Vat Left Closed/Right End Open <b>Square</b>
6	8236019	Drain Tube, Full-Vat, Short, Open Both Ends
7	8236021	Drain Tube, Dual-Vat, Short, Open Both Ends
8	8103550	Drain Tube, Short, Open Both Ends
9	8103551	Drain Tube, Long, Open Both Ends
10	8236240	Drain Tube, Short Full-Vat Left Open/Right End Closed
11	8236242	Drain Tube, Short Dual-Vat Left Open/Right End Closed
12	8236202	Drain Tube, Long Full-Vat Left Open/Right End Closed
13	8236114	Drain Tube, Long Dual-Vat Left Open/Right End Closed
14	8236117	Drain Tube, Long Full-Vat Open Both Ends 15.31"
	8238831	Drain Tube, Long Full-Vat Open Both Ends 18.95"
15	8238833	Drain Tube, Long Full-Vat Open Both Ends 15.49"
16	8236115	Drain Tube, Long Dual-Vat Open Both Ends 15.31"
	8238840	Drain Tube, Long Dual-Vat Open Both Ends 18.95"
17	8238839	Drain Tube, Long Dual-Vat Open Both Ends 15.49"
18	8160772	Sleeve
19	8090969	Clamp
*	8160665	Vinyl Cap
*	8130336	Plug, ½" NPT Square Head Pipe
*	8111071	Tubing, ¼-inch OD Teflon Vent (sold by the foot)
20	8237915	Guard, Filter Lid Splash <b>Oval</b>
20a	130033732	Guard, Filter Lid Splash <b>Square</b>
21	8103755	Valve, 1¼-inch NPT Rotary Actuator
*	8160544	O-Ring (Drain)

\* Not illustrated.

1.5 Electronics and Electrical Components  
 1.5.1 Component Boxes and Associated Components

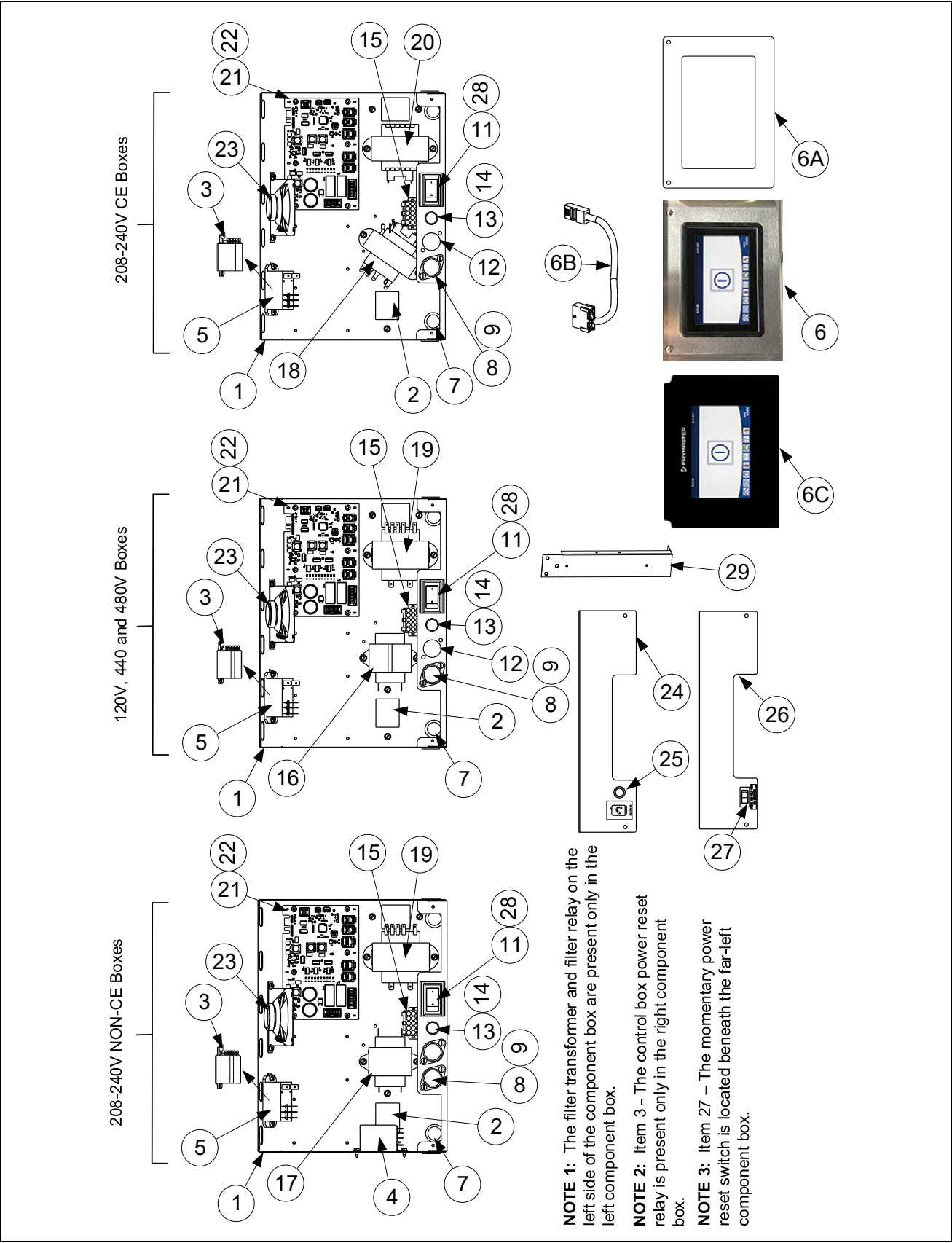

### 1.5.1 Component Boxes cont.

ITEM	PART #	COMPONENT
1	1087745	Box Assembly, Component
2	2200833	Plate, Component Box Strain Relief
√ 3	8074346	Relay, DPDT 20A 120V <i>(used for control power reset in right hand boxes only in domestic and Canadian units)</i>
	8074770	Relay, DPDT 20A 240V <i>(resets control power; right hand boxes only in international units; one in each control box in some units.)</i>
√ 4	8074346	Relay, 120V DPDT 20A <b><i>(used in Canadian models only)</i></b>
√ 5	8074482	Relay, Filter 2 Pole 30A DPDT 24VDC
√ 6	8263748	Controller, Common UI Kit <b><i>(for fryers manufactured from 04/2022 to present)</i></b>
6A	130000329	Bezel, Common UI <b><i>(Metal Bezel only)</i></b>
6B	8076596	4000 Xfer Cable <b><i>(Connects Common UI Controller to SIB Board)</i></b>
√ 6C	1088521SP	Controller, FQ4000 <b>A&amp;W</b> <b><i>(for fryers manufactured prior to 04/2022)</i></b>
	1087769SP	Controller, FQ4000 <b>Arby's</b> <b><i>(for fryers manufactured prior to 04/2022)</i></b>
	1087515SP	Controller, FQ4000 <b>Burger King</b> <b><i>(for fryers manufactured prior to 04/2022)</i></b>
	1089066SP	Controller, FQ4000 <b>Dairy Queen</b> <b><i>(for fryers manufactured prior to 04/2022)</i></b>
	1088523SP	Controller, FQ4000 <b>General Market</b> <b><i>(for fryers manufactured prior to 04/2022)</i></b>
	1088968SP	Controller, FQ4000 <b>Sheetz</b> <b><i>(for fryers manufactured prior to 04/2022)</i></b>
	1088533SP	Controller, FQ4000 <b>Sonic</b> <b><i>(for fryers manufactured prior to 04/2022)</i></b>
	1087847SP	Controller, FQ4000 <b>Taco Bell</b> <b><i>(for fryers manufactured prior to 04/2022)</i></b>
*	8104320	Lanyard, Controller Restraint
7	8100045	Bushing, .875 Diameter 11/16"
8	8070922	Holder, Buss Fuse HPS Screw Type
9	8072278	Fuse, 20 Amp
10	8102446	Plug, Button .50 Heyco Double "D"
√ 11	8074036	Switch, Power
	8073575	Plug, Carling Switch Hole <i>(used on some models without a switch)</i>
12	8071947	Plug, Button .875 Dome
13	8071321	Holder, Fuse <i>(Some models use item 10 here.)</i>
14	8075570	Fuse, 3.5 AMP 250V Fast Acting
15	8075951	Harness, Elec Full Vat Controls SIB J1 to Components
	8075952	Harness, Elec Dual Vat Controls SIB J1 to Components
√ 16	8070800	Transformer, 120V/24V 50VA Filter
√ 17	8070680	Transformer, 208/240V/24V 43VA Filter (Non-CE)
√ 18	8072180	Transformer, 208-240V/24V 50VA Filter (CE, Australia & Korea)
√ 19	8075362	Transformer, 115-240V/24V 80VA
√ 20	8071022	Transformer, 208/240V/24V 75VA (CE, Australia & Korea)
√ 21	1085979	Board, Interface SIB (Smart Interface Board)
22	8090349	Spacer, 4mm X 6mm Aluminium
23	8075829	Speaker, 4 ohms
24	2401735	Guard, Finger JIB Reset
25	8074678	Switch, Momentary JIB Reset <i>(resets ATO; located above JIB/BIB)</i>
26	2401734	Guard Elec. with reset
27	8072659	Switch, Momentary <i>(resets control power; located below left component box)</i>
28	2305038	Guard, RE Box Switch
29	2006654	Brace, Component Box
		<b>See Wiring Diagram(s) on the last page of this manual or in FQE30-T Wiring Diagrams Manual for cable locations.</b>
*	8075553	Cable, P-Bus Left SIB to Right SIB
*	8075555	Cable, P-Bus w/ power Right SIB to VIB (Valve Interface Board)
*	8075551	Cable, C-Bus Right SIB to FIB (Filtration Interface Board)
*	8075549	Cable, C-Bus Right SIB to Right SIB (Connects component boxes together)
*	8076106	Adapter, RJ11 CAN SIB (J8) to Legacy 6-pin (Micro Mate/Lock) CAN (OQS sensor to SIB 5")
*	8074552	Terminator, CAN (ONLY used on OQS harness Y- adaptor)
√ *	8075632	Terminator, CAN End Communication RJ11 (used in SIB J8 if OQS is NOT installed)

\* Not illustrated.

√ Recommended parts.

## 1.5.2 Contactor Boxes

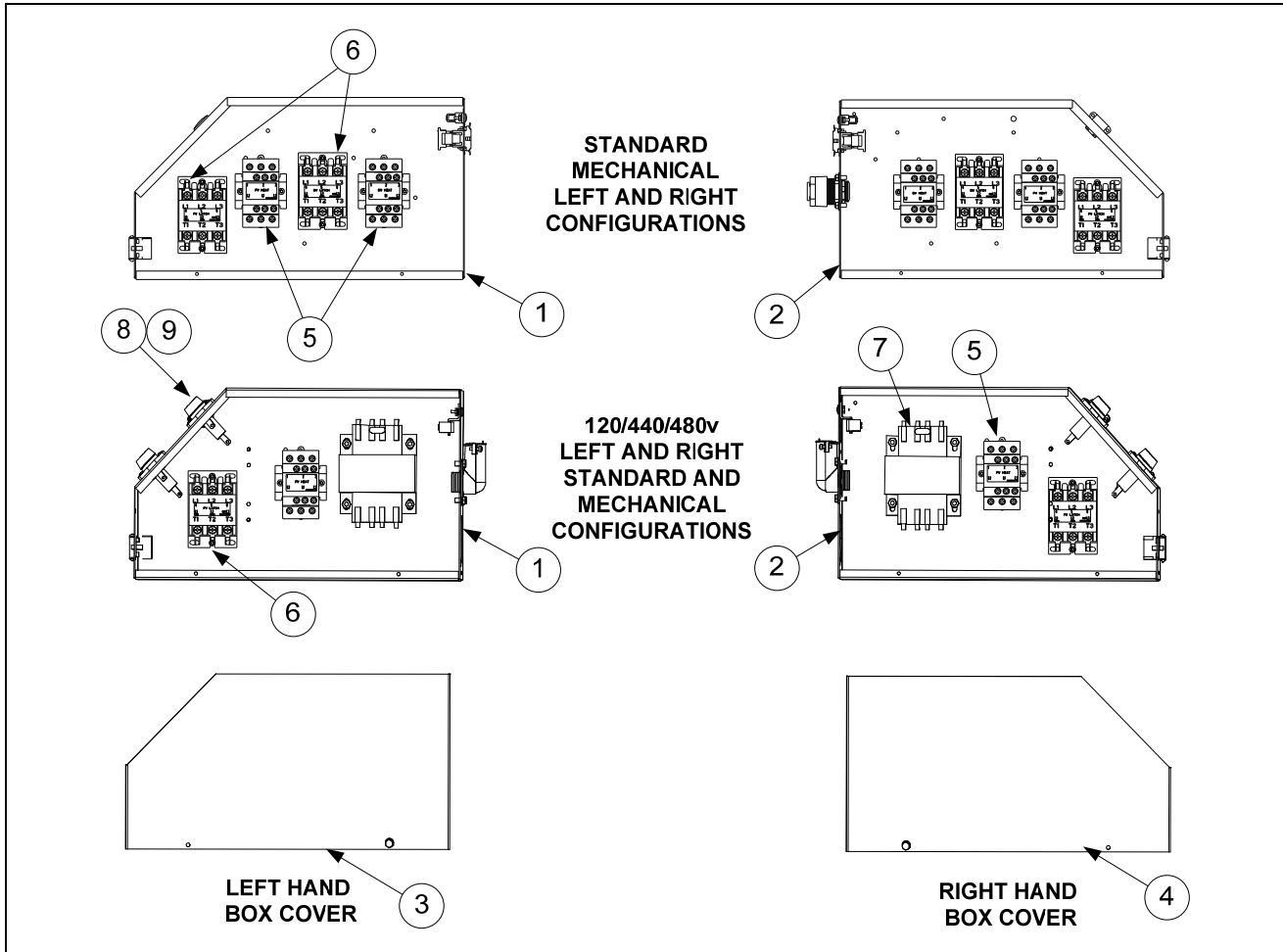

**NOTES:** Left and right contactor box assemblies are mirror images of one another. Except for the box itself, all components of a left-hand assembly are the same as those in the corresponding right-hand assembly and vice versa. The configurations illustrated show all possible components, but a configuration may not have all the components shown.

ITEM	PART #	COMPONENT
1	1068659	Box Assembly, Left Contactor
2	1068661	Box Assembly, Right Contactor
3	2210482	Cover, Left Hand Contactor Box
4	2220482	Cover, Right Hand Contactor Box
*	8070070	Terminal, Ground Lug
√ 5	8263417	Contactor, 24V 50 Amp TESS LC1D32B7 (Heat)
√ 6	8101202	Contactor, 24V 40 Amp (Latch)
7	8070064	Transformer, 480V/120V 150VA
8	8070922	Holder, Bus Fuse
9	8072278	Fuse, 20 Amp
*	2210610	Bracket, Left Hand Contactor Box Mounting
*	2220610	Bracket, Right Hand Contactor Box Mounting
		<b>See Section 1.14 for Power Cords</b>
*	8070012	Relay, Tilt Switch 18 Amp 1/3 HP 24 V Coil

\* Not illustrated.

√ Recommended parts.

### 1.5.3 Heating Element Assemblies and Associated Parts

#### 1.5.3.1 Element Assemblies and Hardware

**FULL-VAT ELEMENT ASSEMBLY**

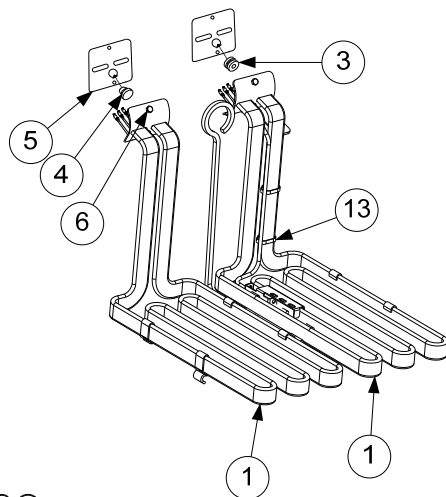

**DUAL-VAT ELEMENT ASSEMBLY**

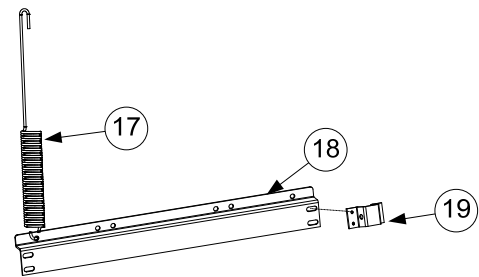
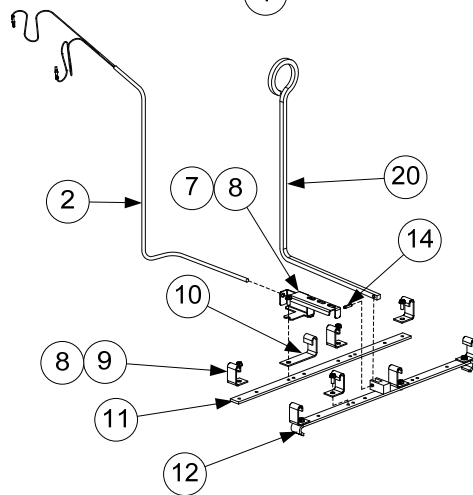
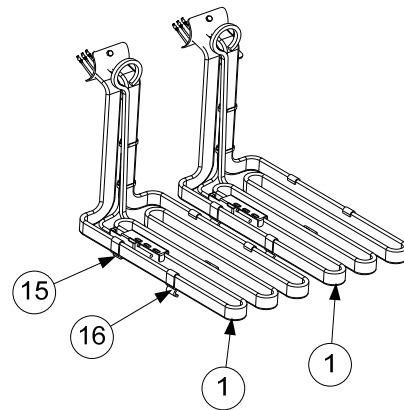

**NOTES:**

The dual-vat assembly is almost the same as the full-vat assembly except for having two of Items 2, 3, 7, 14, 15, 16 and 20. The only difference between element assemblies for different voltage and kW ratings is the element itself (Item 1).

Items 17, 18 and 19 are shown as associated parts. They are not part of either assembly.

**NOTE: These elements apply only to FQE30 Series Fryers.**

### 1.5.3.1 Element Assemblies and Hardware cont.

ITEM	PART #	COMPONENT
1		Element Kits – <i>includes gaskets, grommets, tie wraps, screws and nuts.</i>
	8262198	200V 7.0 kW <b>(220V 8.5kW used in some export 3-phase 4-wire WYE units)</b>
	8262201	200V 8.5 kW
	8262192	208V 7.0 kW
	8262197	208V 8.5 kW
	8262200	220V 7.0 kW <b>(220V 8.5kW used in some export 3-phase 4-wire WYE units)</b>
	8262193	230V 7.0 kW
	8262199	230V 8.5 kW
	8262194	240V 7.0 kW
	8262195	440V 7.0 kW
	8262202	440V 8.5 kW
	8262196	480V 7.0 kW
	8262203	480V 8.5 kW
√ 2	8263450	Kit, Touch Elec Temperature Probe- includes tie wraps and grommet.
3	8160681	Grommet, Probe
4	8160480	Plug, .375-inch Dome
5	8160688	Gasket, Element
6	8091003	Screw, 10-32 X 3/8-inch Hex Head SS
*	8090766	Nut, 10-32 Keps Hex Head SS
*	2304028	Wrench, Element Tube Nut Spanner
7	2303714	Bracket, Temperature Probe 7.0 kW (14kW)
	2300784	Bracket, Temperature Probe 8.5 kW (17kW)
8	8090518	Screw, 8-32 X 3/8-inch Slotted Hex Head
9	2601201	Clamp, Element (Short)
10	2300781	Clamp, Element (Long)
11	2304902	Support, Full-Vat Element Rear
12	8235621	Support, Full-Vat Element Front
13	8090567	Tie-Wrap, Metal
14	8101212	Pin, .125 X .5-inch Split
15	2304903	Support, Dual-Vat Element Rear Dual Vat
16	8238085	Support, Dual-Vat Element Front Dual Vat -14kW
	8238086	Support, Dual-Vat Element Front Dual Vat -17kW
17	8103030	Spring, Element Lift Left
	8103031	Spring, Element Lift Right
18	2201190	Bracket, Lower Spring Single Foot Print
	2200464	Bracket, Lower Spring
19	2200733	Bracket, Lower Spring Mating
20	8101233	Handle, Element Lift

\* Not illustrated.

√ Recommended parts.

### 1.5.3.2 Element Tube Assemblies

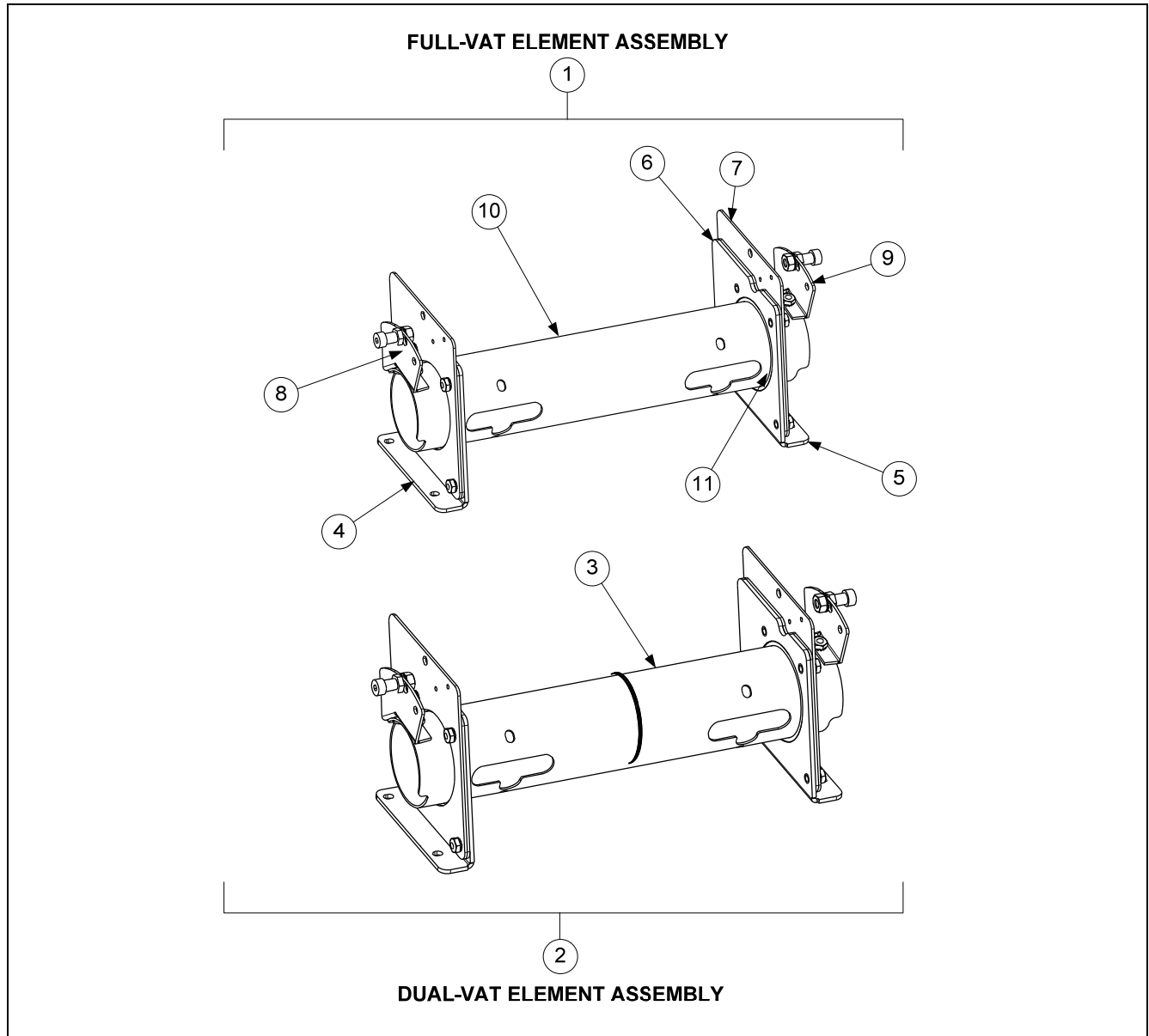

ITEM	PART #	COMPONENT
1	1080297SP	Tube Assembly RE Element, Full-Vat
2	1080298SP	Tube Assembly RE Element, Dual-Vat
3	8103246	Bushing and Tube Assembly, Dual-Vat
4	1080315	Bracket Assembly, LH Element Tube Support
5	1080316	Bracket Assembly, RH Element Tube Support
6	2200122	Plate, Element Tube Support Inner
7	2200123	Plate, Element Tube Support Outer
8	1067651SP	Bracket Assembly, LH Upper Spring ( <i>use 1066569SP for 17kW</i> )
9	1067652SP	Bracket Assembly, RH Upper Spring ( <i>use 1066570SP for 17kW</i> )
10	8102992	Tube, Full Vat Element Mounting
11	8102993	Bushing, Tube End Teflon
*	8262598	Kit, Tilt Switch
*	8074742	Switch, Long Lever High Temp

\* Not illustrated.

### 1.5.4 FIB (Filtration Interface Board) Filter and Top Off Box Components

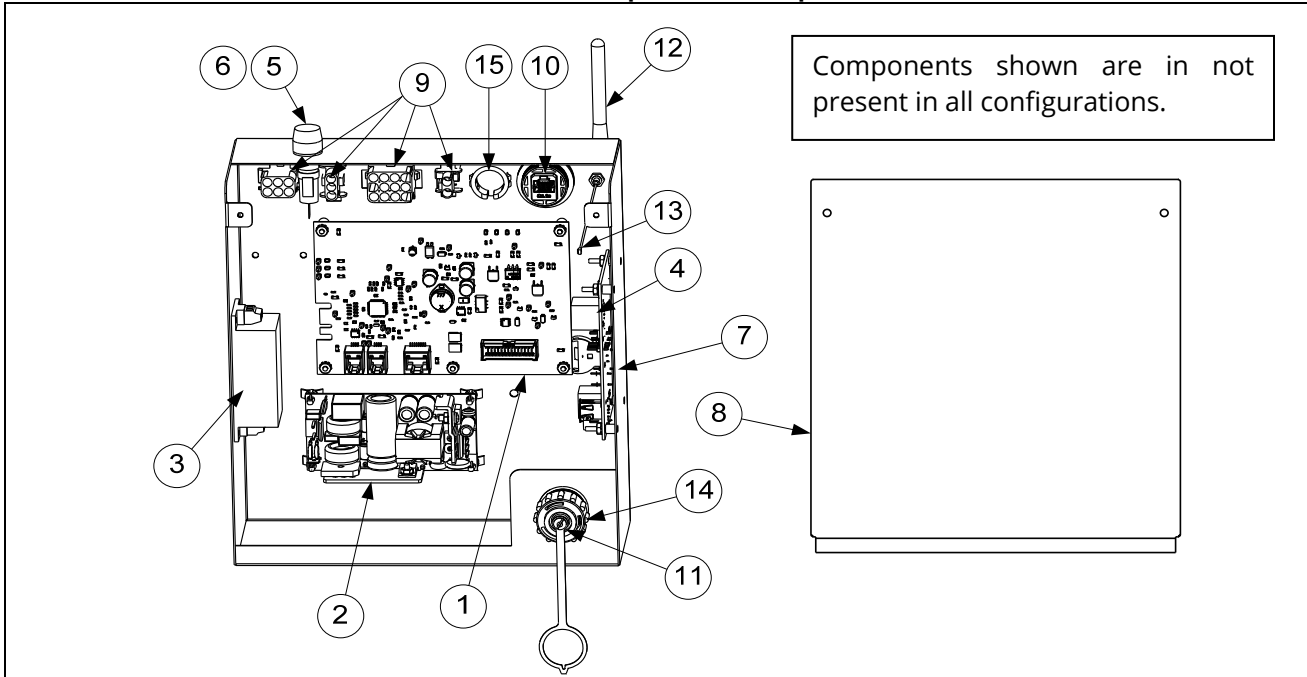

ITEM	PART #	COMPONENT
	1087747SP	Box Assembly, ATO/FIB Filter with KCCM SUI
√ 1	<a href="#">1087513SP</a>	Board, FIB w/ Software <b>General Market (Burger King, Arby's, etc.)</b>
	<a href="#">1087535SP</a>	Board, FIB w/ Software <b>Taco Bell</b>
√ 2	<a href="#">8263684</a>	Power Supply, 24VDC 130W ATO, Actuators, Filter Pump, Top Off Pump
√ 3	<a href="#">8075974</a>	Power Supply, 24VDC, 15W for KCCM SUI board
*	1087247	Holder Assembly, Fuse with Leads (used with the KCCM SUI Board)
√ 4	<a href="#">1088447SP</a>	PCB, Assy FQ4000 KCCM/SUI <b>Taco Bell</b>
	<a href="#">8076148</a>	PCB, Assy FQ4000 KCCM/SUI
√ 5	<a href="#">8075570</a>	Fuse, 250VAC 3.5A Fast Acting
6	<a href="#">8071321</a>	Holder, Fuse
7	<a href="#">1087746</a>	Box, Assembly
8	2401727	Cover, ATO/Filter Box
9	<a href="#">8076240</a>	Harness, Bulk Oil/ATO/FIB (J1 (30-pin) FIB to illustrated connectors inside FIB Box) <b>(Prior to 06-2022)</b>
	8076613	Harness, Bulk Oil/ATO/FIB (J1 (30-pin) FIB to illustrated connectors inside FIB Box) <b>(After 06-2022)</b>
10	8075967	Coupler, 8PBC to 8PBC
11	8075970	Cap, Dust
12	8075975	Antenna
13	<a href="#">8076225</a>	Cable, U. FL to RP-SMA Bulkhead (attaches from item 12 to Item 4)
14	<a href="#">8075969</a>	Cable, USB Receptacle Mount (USB end attaches to Item 4)
15	<a href="#">8071926</a>	Bushing, .875 Split
*	<a href="#">8074056</a>	Connector, 3-Wire Snap
*	WIR1179	Wire Assy, FQLAU Filter/ATO Power (Connects item 1 and item 2)
<b>See Wiring Diagram(s) on the last page of this manual or in FQE30-T Wiring Diagrams Manual for cable locations.</b>		
*	<a href="#">8075632</a>	Terminator, CAN End Communication RJ11 (FIB J4)
*	8075977	Cable, RJ45 Cat5E 7.87" (From Item 10 to Item 4)
*	<a href="#">8076314</a>	Harness, Filter/ATO Power/Control 24" (C5 (6-pin) Rear FIB Box - C5 (6-pin) Left Component Box)
*	<a href="#">8076242</a>	Harness, KCCM SUI Communication/Power (RJ45 item #4 to J4 FIB and to item #3)
*	<a href="#">8076241</a>	Harness, Power Supply (From item #2 to Snap Connectors)
*	<a href="#">8075551</a>	Cable, C-Bus Right SIB (J7) to FIB (Filtration Interface Board) (J3)
*	<a href="#">8075810</a>	Cable, FIB to VIB Actuator Power (used from FIB item #1 (J2) to VIB (J4) and from VIB (J3) to VIB (J4))

\* Not illustrated √ Recommended parts.

### 1.5.5 VIB (Valve Interface Board) Components

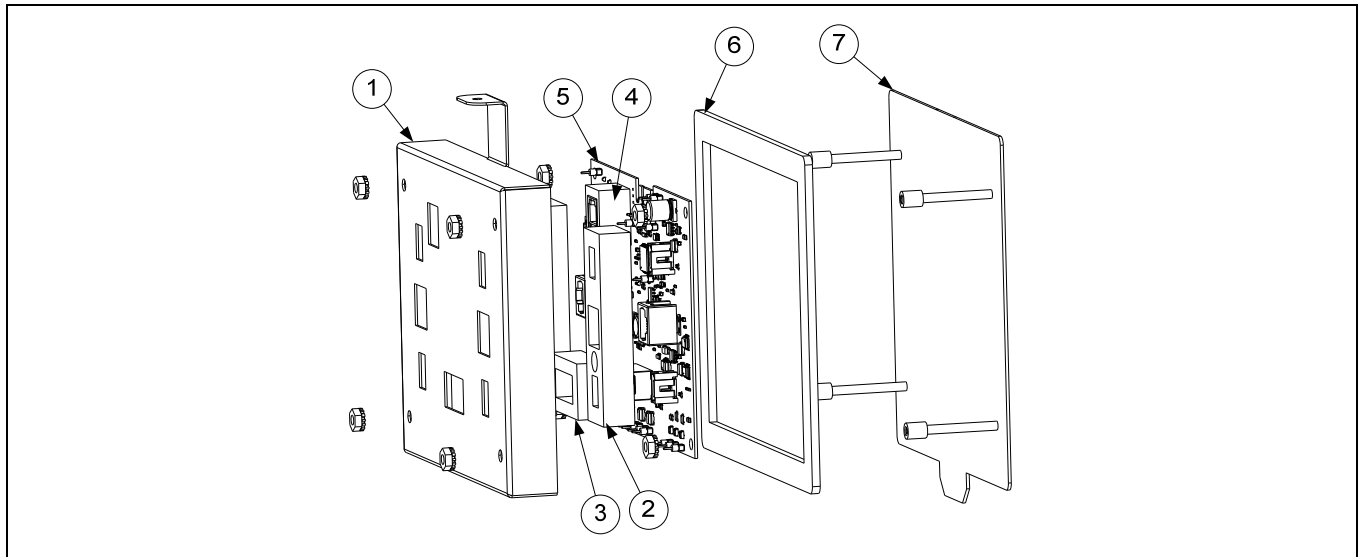

ITEM	PART #	COMPONENT
√	1087537	VIB Board Assembly
1	8242346	Cover, VIB Board Housing
2	8161015	Gasket, Actuator Power VIB
3	8161013	Gasket, 20 pin VIB Connector
4	8161014	Gasket, P-Bus VIB Connector
5	1087534SP	Board, VIB with SW
6	8160820	Seal, Linear Actuator Board
7	1087820	Box, Linear Actuator Stud

√ Recommended parts.

### 1.5.6 USB Connector

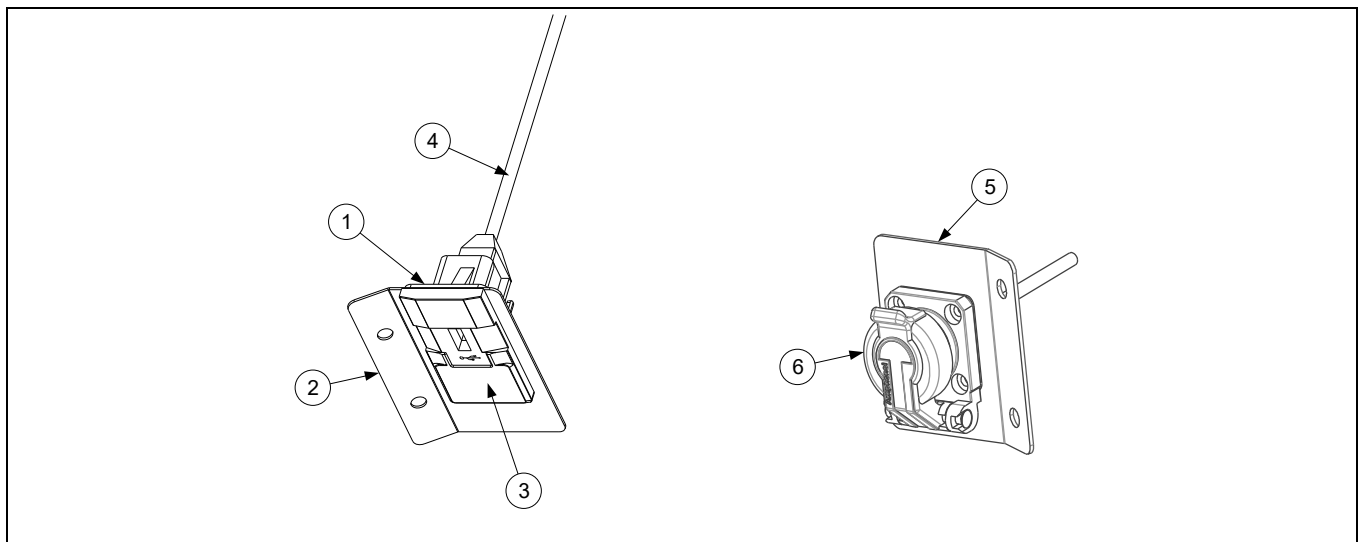

ITEM	PART #	COMPONENT
	1084737	Bracket Assy, USB Mounting Elec
1	2207520	Plate, Backing USB Bezel
2	2600193	Bracket, Elec USB with Spreader
3	8074989	Bezel, USB Port
4	8074990	Cable, USB
	130000191	Bracket Assy, USB Mounting Elec
5	130000190	Bracket, Elec USB Mounting
6	8105041	USB, Self-Closing Flange

## 1.5.7 Wiring

### 1.5.7.1 Contactor Box Wiring Assemblies – 12-Pin Dual-Vat C-1

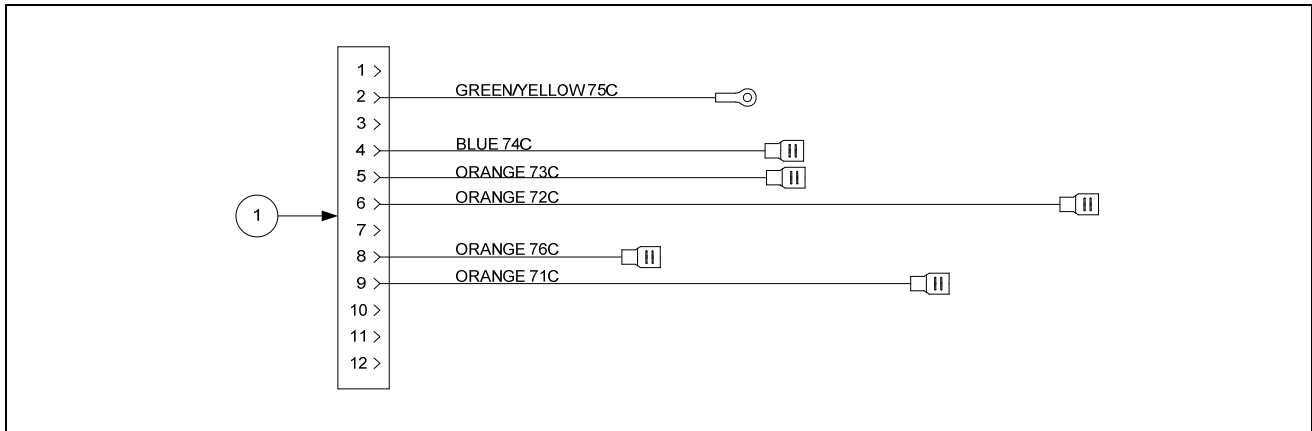

ITEM	PART #	COMPONENT
1	1087518SP	Contactor Box Harness Assembly Dual Vat

### 1.5.7.2 Contactor Box Wiring Assemblies – 12-Pin Full-Vat C-1

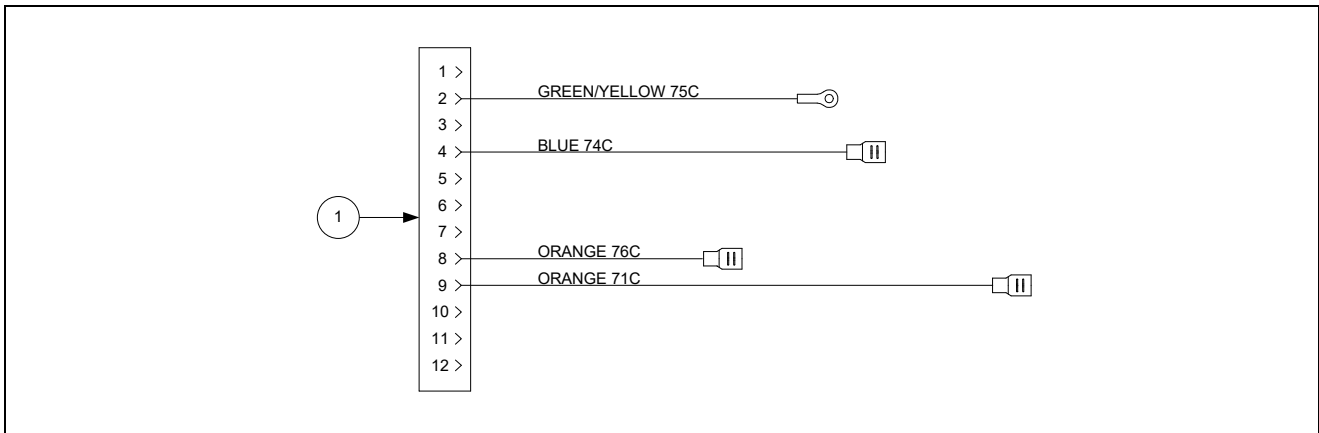

ITEM	PART #	COMPONENT
1	1087516SP	Contactor Box Harness Assembly Full Vat

### 1.5.7.3 Contactor Box Wiring Assembly - 6-Pin (Left Element)

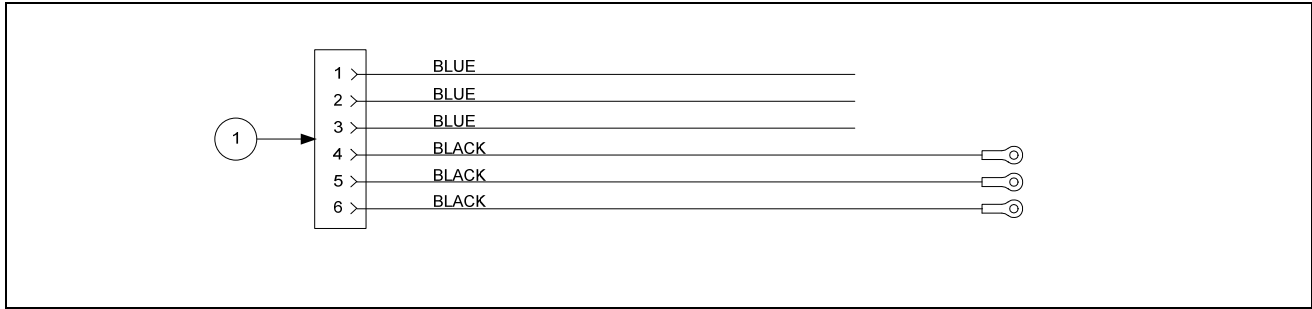

ITEM	PART #	COMPONENT
1	1068744SP	14/17 kW Mechanical Contactor

### 1.5.7.4 Contactor Box Wiring Assembly - 9-Pin (Right Element)

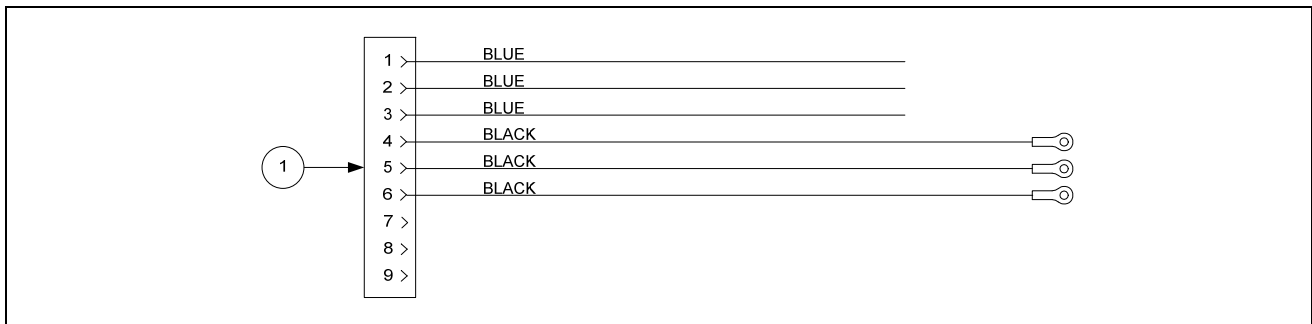

ITEM	PART #	COMPONENT
1	1068745SP	14/17 kW Mechanical Contactor

### 1.5.7.5 Main Wiring Harnesses

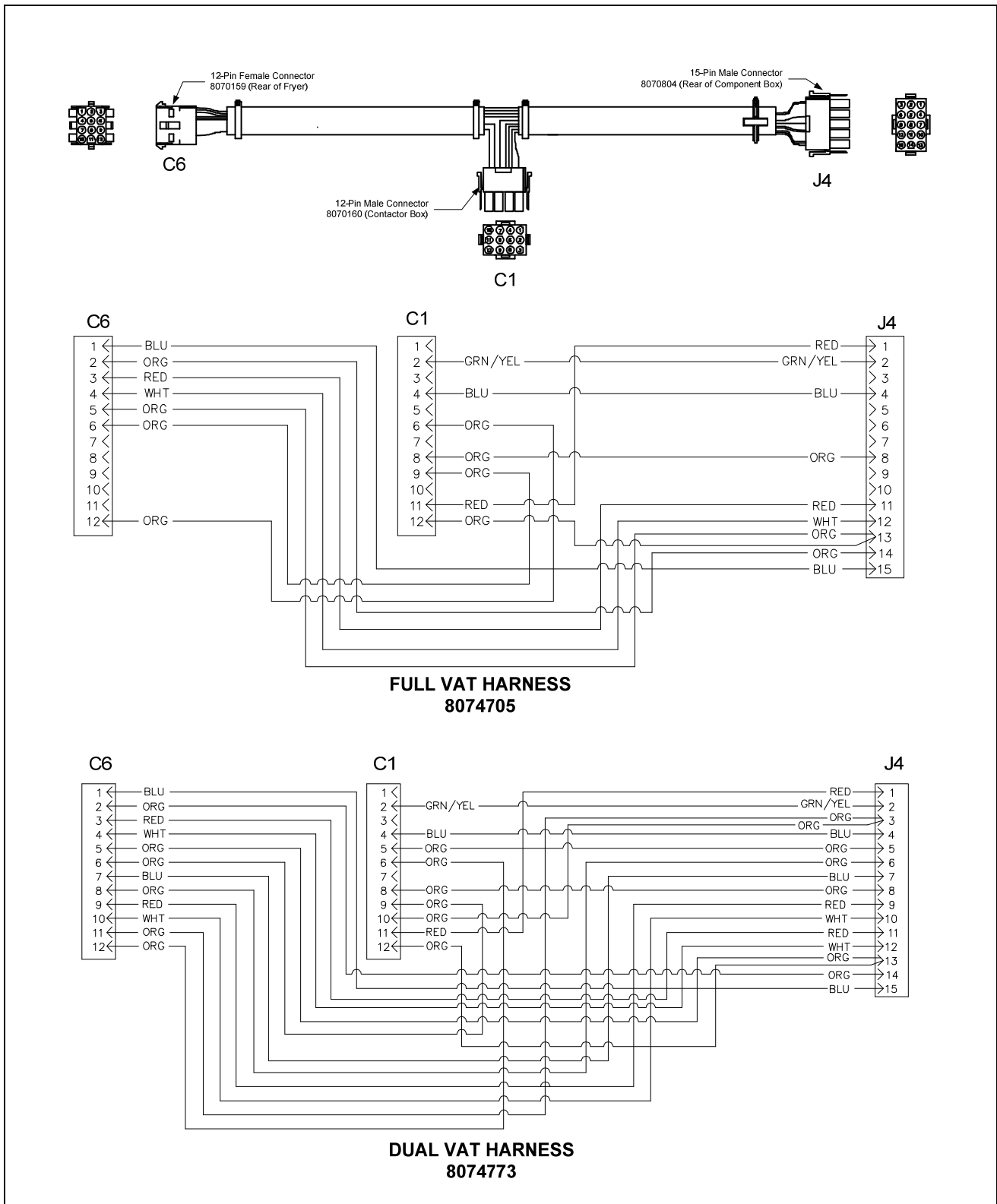

ITEM	PART #	COMPONENT
1	8074705	Full Vat Main Wiring Harness J4 to C1 and C6
2	8074773	Dual Vat Main Wiring Harness J4 to C1 and C6

See the FQE30-T Wiring Diagrams Manual.

### 1.5.7.6 Component Box Wiring Harnesses

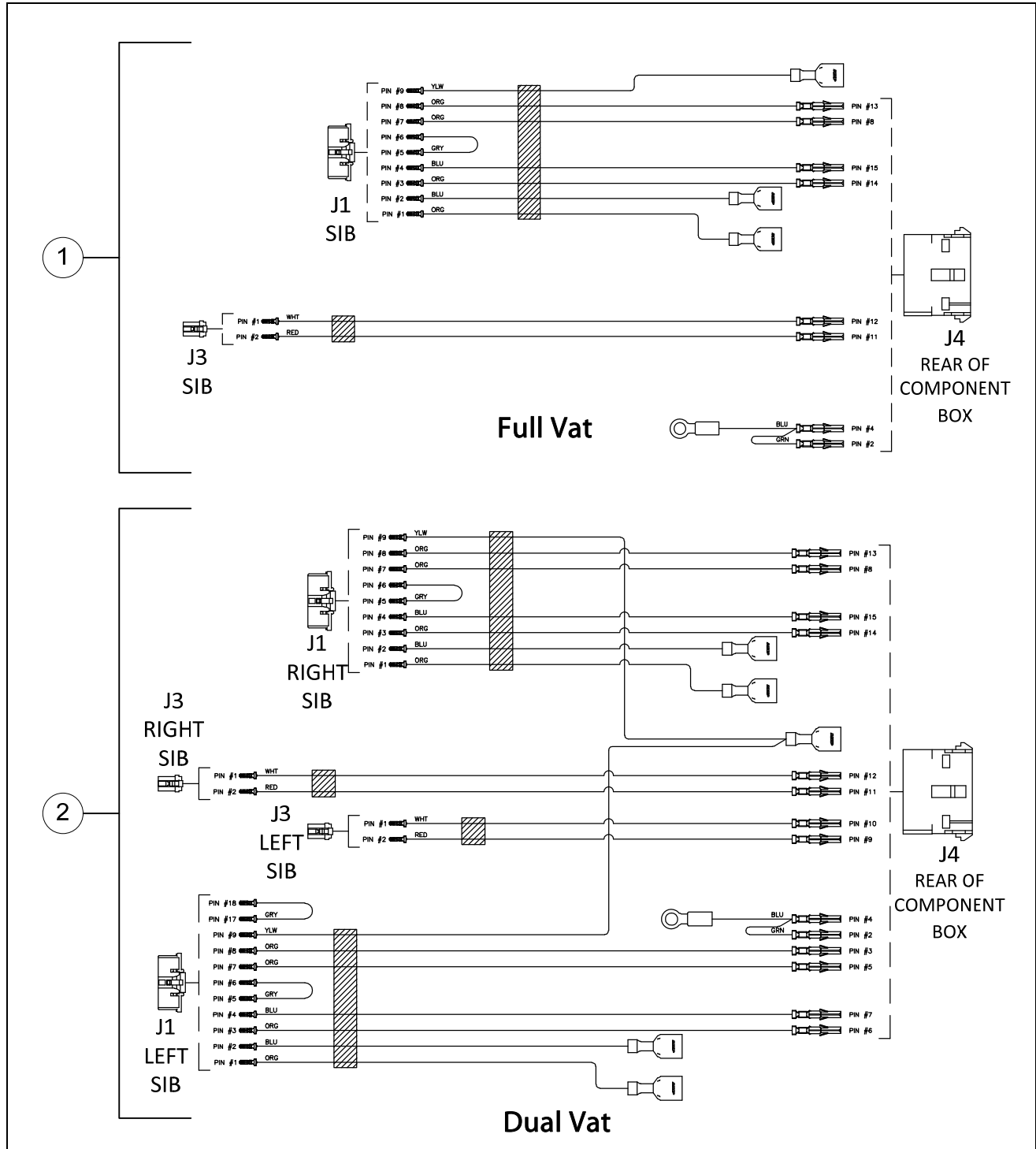

ITEM	PART #	COMPONENT
1	8075951	Full Vat Control Harness J4 to J1 and J3
2	8075952	Dual Vat Control Harness J4 to J1 and J3

See the FQE30-T Wiring Diagrams Manual.

### 1.5.7.7 FIB Box Wiring Harness

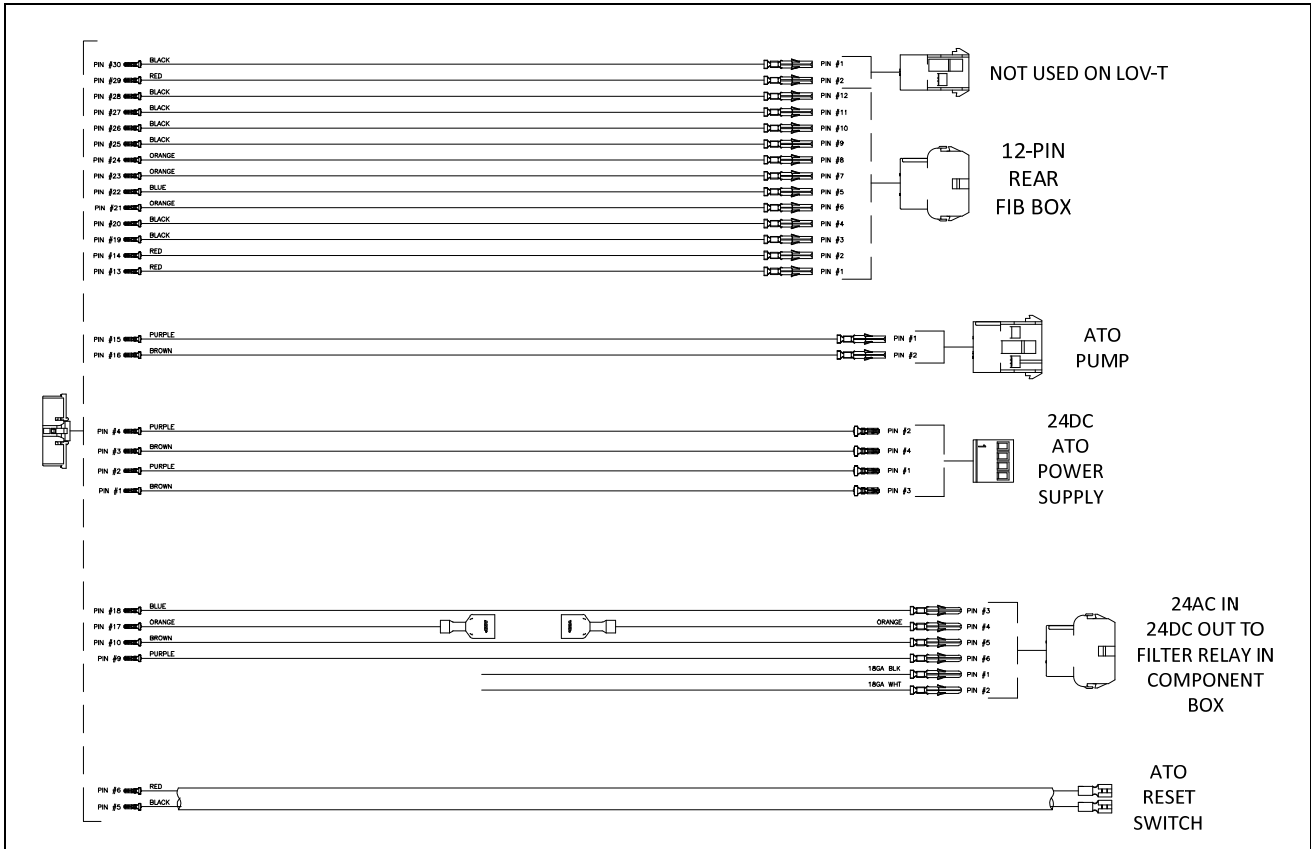

ITEM	PART #	COMPONENT
1	8076240	Harness, Bulk Oil, Topoff /FIB ( <i>Prior to 06/2022</i> )
2	8076613	Harness, Bulk Oil, Topoff /FIB ( <i>After 06/2022</i> )

## 1.6 Frypot Assemblies and Associated Parts

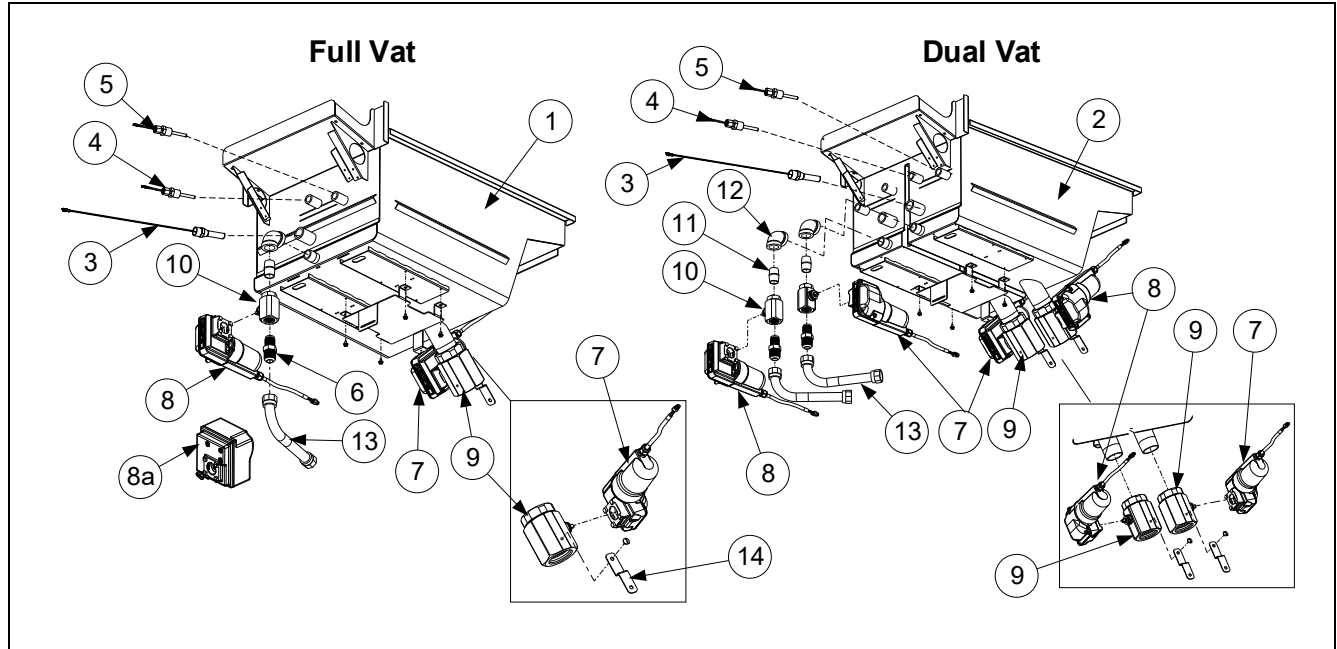

ITEM	PART #	COMPONENT
1	8238947	Frypot, Full-Vat
2	8238952	Frypot, Dual-Vat
√ 3		Thermostat Assembly, High-Limit Long Standard
	8262454	Non-CE Full Vat 425°F (218°C) (17kW FV and 14kW FV) (Color Coded Black 8067543)
	<a href="#">8262456</a>	Non-CE Dual Vat 435°F (224°C) (22kW, 17kW DV and 14 kW DV) (Color Coded Red 8068035)
	<a href="#">8262455</a>	CE Full and Dual Vat 415°F (213°C) (14kW and 17kW CE) (Color-Coded Yellow 8068132)
√ 4	<a href="#">8263544</a>	Probe, ATO (Topoff) RTD Kit
√ 5	<a href="#">8263287</a>	Probe, VIB (Auto Filtration) RTD Kit
6	<a href="#">8101668</a>	Adaptor, Male 5/8" OD x 1/2"
√ 7	<a href="#">8075809</a>	Actuator, Rotary 24VDC ( <b>BLUE</b> )
√ 8	<a href="#">8075808</a>	Actuator, Rotary 24VDC ( <b>BLACK</b> )
√ 8a	<a href="#">130013720</a>	Actuator, Rotary 24VDC ( <b>GRAY SQUARE</b> )
√ 9	<a href="#">8104353</a>	Valve, 1¼-inch NPT Rotary Actuator
*	<a href="#">8160544</a>	O-Ring (Drain)
√ 10	<a href="#">8103754</a>	Valve, ½" NPT Return Rotary Actuator
11	<a href="#">8130022</a>	Nipple, ½" x Close NPT BM
12	<a href="#">8130062</a>	Elbow, ½-inch BM 90°
13	<a href="#">8101067</a>	Flexline, 5/8" OD x 8.50" Long
14	<a href="#">2207386</a>	Support, Drain
*	<a href="#">8161118</a>	Insulation, Superwool EL30

√ Recommended parts.

## 1.7 Oil Return Manifolds

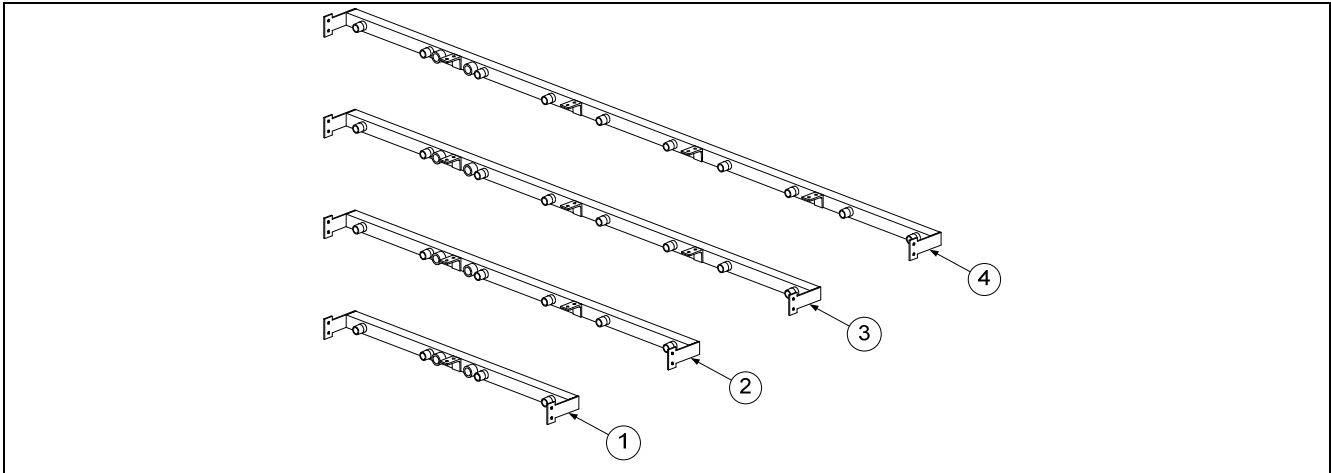

ITEM	PART #	COMPONENT
1	8103015	Manifold, Two-Station Fryer
2	8103016	Manifold, Three-Station Fryer
3	8103017	Manifold, Four-Station Fryer
4	8103018	Manifold, Five-Station Fryer
*	8130907	Cap, 15/16-inch Valve

\* Not illustrated.

Pump plumbing and pump orientation may differ somewhat from illustration depending on configuration and date of manufacture.

### 1.8 Filtration System Components

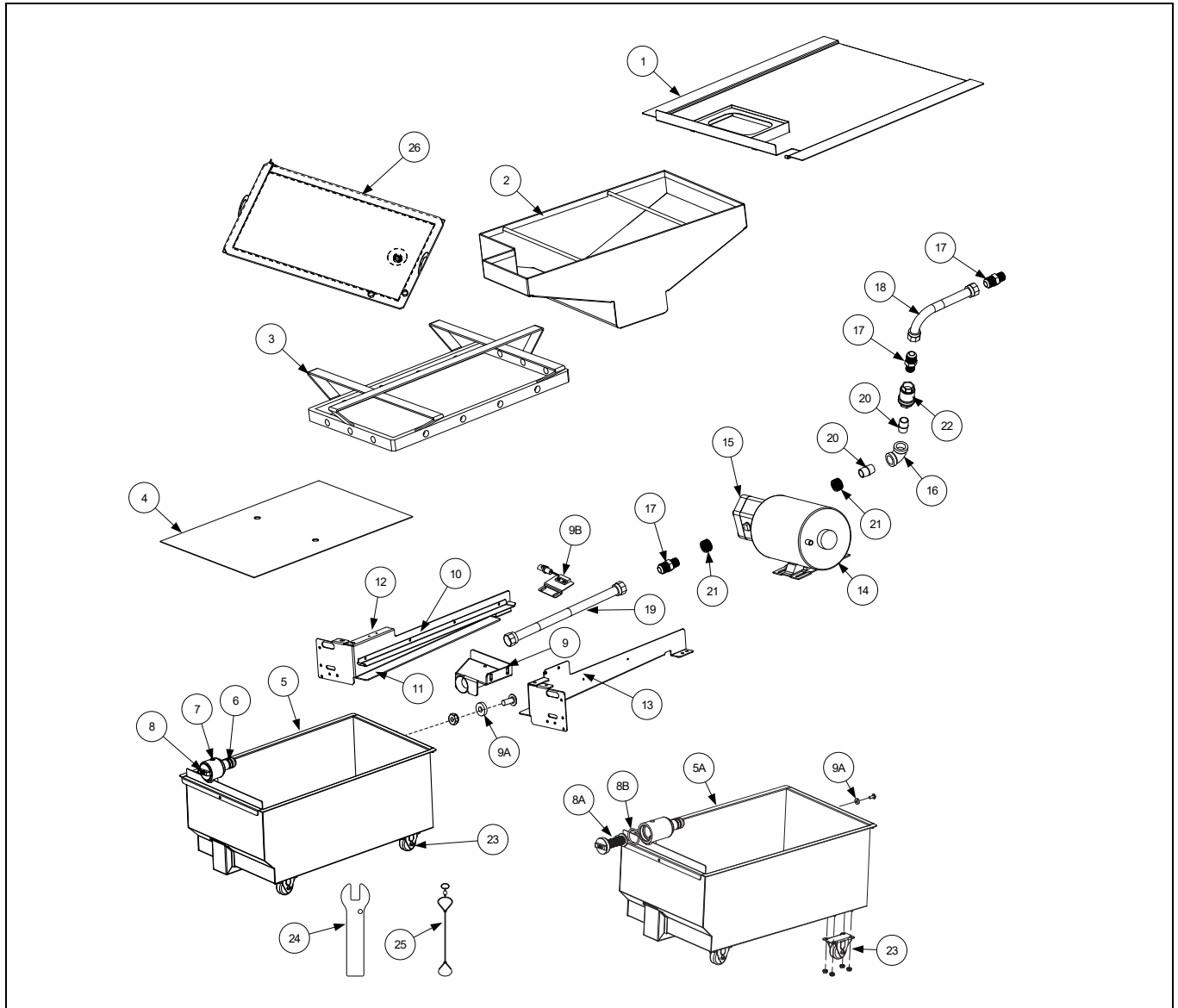

ITEM	PART #	COMPONENT
1	8238810	Lid, Filter Pan - <b>OVAL opening prior to 10/2022</b>
	130035860	Lid, Filter Pan - <b>SQUARE opening after 09/2022</b>
2	8238626	Crumb Tray ( <b>Use TBD for use with Filter Leaf</b> )
3	8103289	Hold-Down Ring for Pad 11.20 x 19.10
4	8122025	Sana Grid Filter Screen
5	1087700SP	Pan, Assy Filter with casters <b>prior to 03/2019</b>
	1088399SP	Pan, Assy Filter with casters <b>after to 03/2019-10/2022</b>
	TBD	Pan, Filter with casters ( <b>For use with Filter Leaf only</b> )
5A	130000514SP	Pan, Assy, Filter Half Size ( <b>2-Vat Fryer</b> ) with casters ( <b>after 10/2022</b> )
✓ 6	8263288	O-Ring (Pkg. of 5; used with Item 5; two required)
7	8130568	Plug, 1/8" Socket Head Pipe (used with Item 5)
8	8238335	Screen, Suction Line Filter ( <b>Short</b> )
8A	8239651	Screen, Suction Line Filter ( <b>Long</b> )
8B	8161213	O-Ring, Inline Filter Cap ( <b>for use with 8239651</b> )
9	8239429	Suction Tube ( <b>2-Vat Fryer</b> ) ( <b>prior to 11/2022</b> )
	130000512	Suction Tube Two Vat LOV™ ( <b>2-Vat Fryer</b> ) ( <b>after 10/2022</b> ) may differ slightly in appearance

✓ Recommended parts

1.8 Filtration System Components cont.

ITEM	PART #	COMPONENT
9A	8103007	Magnet, Pull Ring
9B	1068080SP	Assembly, Filter Pan Switch
√ *	1065876SP	Sensor, Magnet
10	2306616	Rail, Upper
11	2306619	Rail, Lower
12	2203275	Support, Left Filter Pan
13	1068487	Support, Right Filter Pan
√ 14		Motor and Gasket Kit
	8261785	100V 50/60 Hz
	8261712	115V 50/60 Hz
	8261756	208V 50/60 Hz
	8261270	220-240V 50/60 Hz
	8261755	250V 50/60 Hz
√ 15	8263192	Pump and Gasket Kit, 8 GPM (includes gasket 8160093, screws 8091020 & washers 8090194)
	8160093	Gasket, Pump/Motor
*	8091020	Cap Screw, 5/16-inch-18 5.00" NC Hex ( <i>Connects pump to motor</i> ) (use 8090194 washers)
16	8130062	Elbow, ½" 90° BM
17	8101668	Adapter, ⅝" to ½" NPT Male
18	8101067	Flexline, 8.5-inch Oil Return (to oil return manifold)
19	8101057	Flexline, 13-inch Oil Return (to filter suction tube)
20	8130022	Nipple, ½-inch x Close NPT BM
21	8130763	Bushing, ¾" OD x ½" ID
22	8104878	Check Valve ½" NPT 1 PSI
23	8104137	Caster, 2.00-inch
*	8071105	Heater Strip Assembly, 100-120V 25W 18"
*	8071098	Heater Strip Assembly, 208-250V 25W 18"
24	2401086	Wrench, Pre-Filter Cap
25	8104167	Lanyard, Filter Screen Wrench
26	TBD	Leaf Assy, Filter ( <b>Only for use with Filter Pan 108-TBDSP</b> )

\* Not illustrated. √ Recommended parts.

**1.9 ATO (Auto Top-Off) Components**

**1.9.1 JIB Cradle, JIB Cap / Pick-Up Assembly and JIB (ATO) Reset Switch**

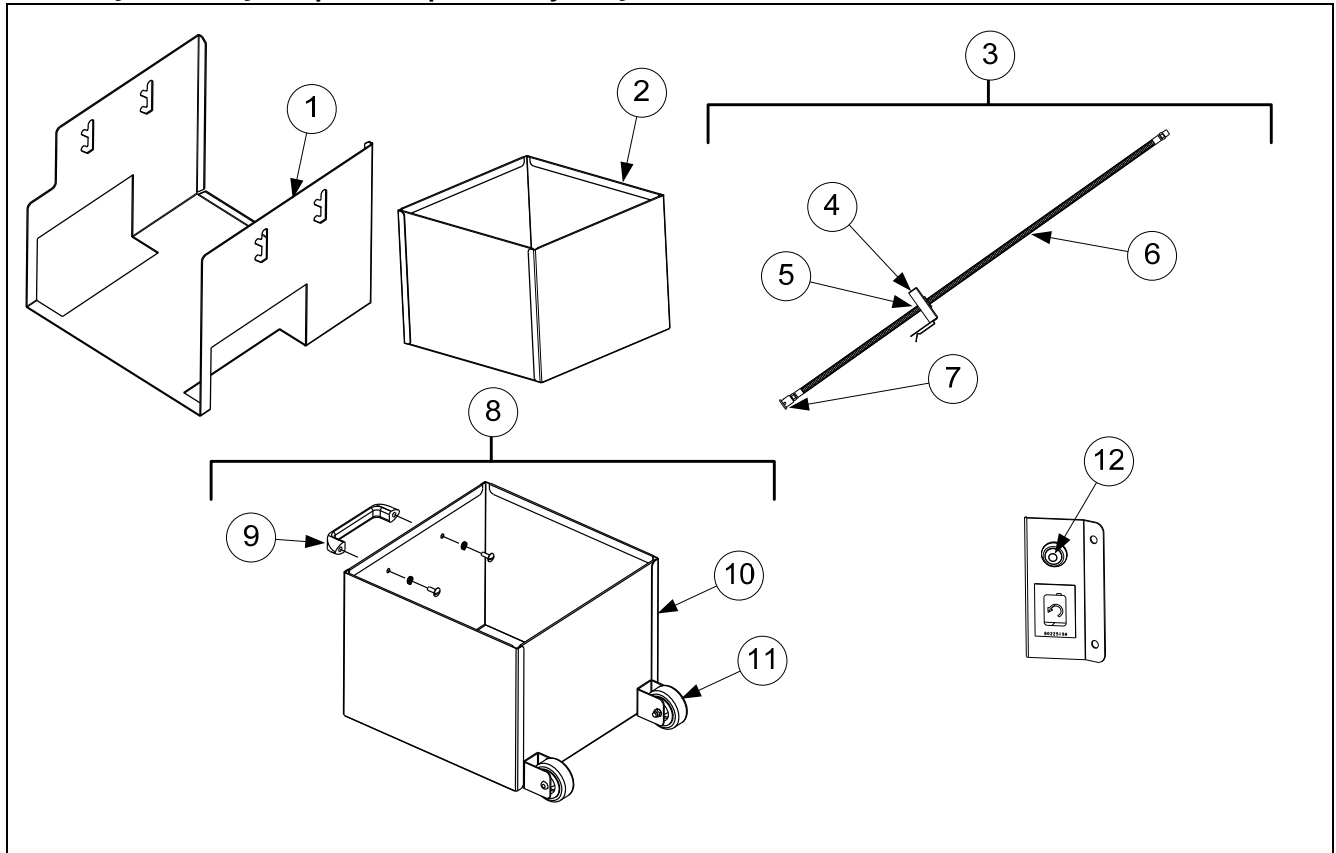

ITEM	PART #	COMPONENT
1	2600197	Cradle, JIB Gas
*	8090402	Screw, Thumb ¼-20 x ½"
2	8242298	Box, JIB
3	1082005SP	Cap, JIB Assembly (use 1082047 for Intl BIB)
4	1082001	Cap, JIB (use 1082002 for Intl. BIB)
5	8160870	Clamp
6	8103823	Hose, JIB
7	8237738	Tip Assembly, JIB Suction Hose
8	1086895	Box Assembly, JIB w/ Handle and Casters
9	8100180	Handle
10	8239145	Box, W/A JIB w/ handle
11	8122337	Caster, 2"
12	8074678	Switch, Momentary JIB Reset

\* Not illustrated. ✓ Recommended parts.

## 1.9.2 ATO Pump Assembly

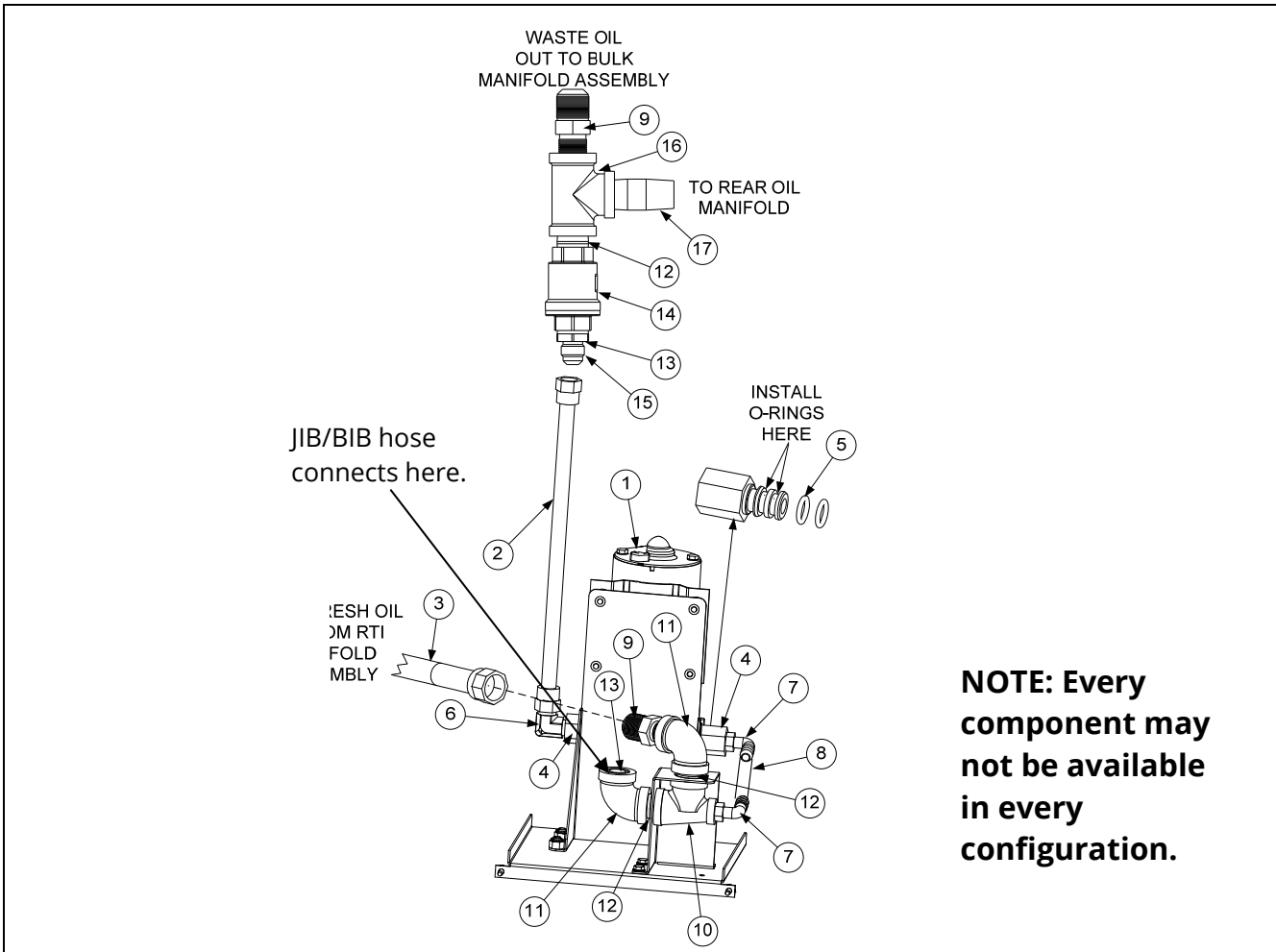

ITEM	PART #	COMPONENT
√ 1	1084372	Pump, Shurflo 24VAC
	1085673	Pump, Shurflo 24VAC (CE)
2	8103265	Flexline, ½" OD x 24" (3/8" Flare) ( <b>3/4/5 Vat Fryers</b> ) (Out to oil return manifold)
	8103591	Flexline, ½" OD x 8-inch ( <b>2-Vat Fryer</b> ) (Out to oil return manifold)
3	8101069	Flexline, ⅝" OD x 29.5-inch (In from RTI fresh oil solenoid)
4	8103578	Fitting, Shurflo Pump
5	8160782	O-Ring, Viton #111
6	8130940	Elbow, ¼" NPT x ⅜" Flare
7	8160710	Fitting, ¼" NPT x ½" Barb
8	8111166	Hose, Silicone Braided 5" (sold by the foot) (Cut and attach to item 7 with a ty wrap)
9	8101668	Adaptor, Male ⅝" OD x ½"
10	8237411	Bracket, JIB Elbow Elec LOV with Reducing Tee
11	8130062	Elbow, ½" BLK 90° NPT BM
12	8130022	Nipple, ½" x Close NPY BM
13	8130304	Bushing, ½" x ¼" Flush
14	8104878	Check valve, ½" NPT 1psi
15	8103270	Fitting, ⅜" Flare x ¼" NPT
16	8130003	Tee, ½" x ½" x ½" BM
17	8130298	Nipple, ½" x 2" NPT BM

\* Not illustrated.

√ Recommended parts.

## 1.10 Shortening Melting Unit

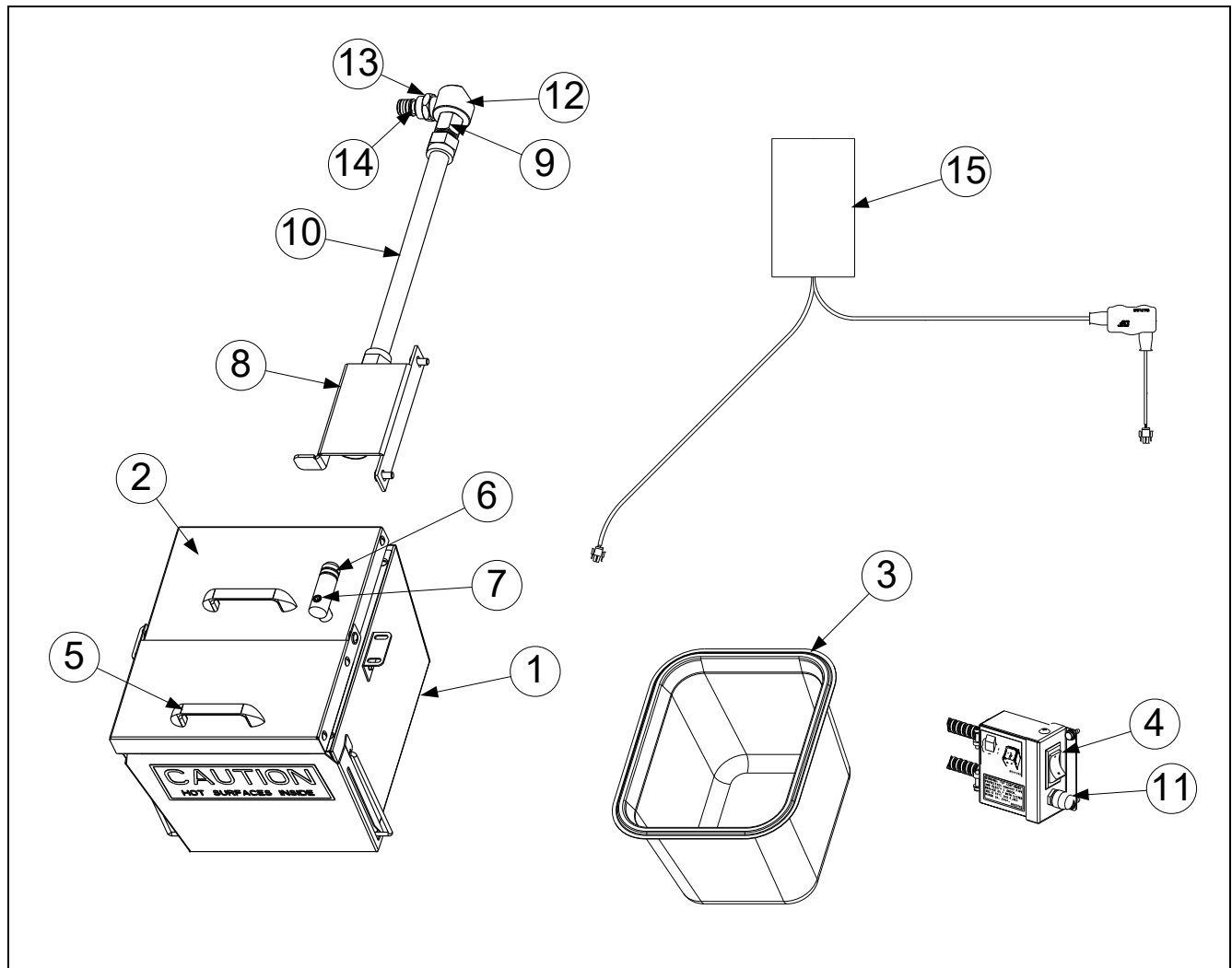

ITEM	PART #	COMPONENT
	<b>1083754SP</b>	Assembly, Heated Shortening
1	1083753	Box Assembly, Heated Shortening
2	1083744	Assembly, Heated Shortening Lid
3	8103957	Pan, Heated Shortening
4	8074036	Switch
5	8100180	Handle
√ 6	8261392	O-Ring (Pkg. of 5)
7	8130568	Plug, 1/8-inch Socket Head Pipe
8	8238319	Bracket W/A, Shortening Suction
9	8101669	Adaptor, Female 7/8" OD x 1/2"
10	8101055	Flexline, 3/8" OD x 11.5-inch
11	8071321	Holder, Fuse
√ *	8071555	Fuse 5 Amp
12	8130908	Adapter, 1/2" NPT 90°
13	8103820	Fitting, Quick Connect Shurflo Pump
√ 14	8160782	O-Ring, Viton #111
15	8075268	Strips, Hot Box Heater with controller
*	8071098	Heater Strip Assembly, 240V, 25W 18"
*	8071419	Heater Strip Assembly, 240V, 45W 36"
*	8071473	Heater Strip Assembly, 240V, 70W 56"

\* Not illustrated.

√ Recommended parts.

1.11 Bulk Dispose and Fresh Oil

1.11.1 Bulk Dispose, Fresh Oil Manifold and Accessories

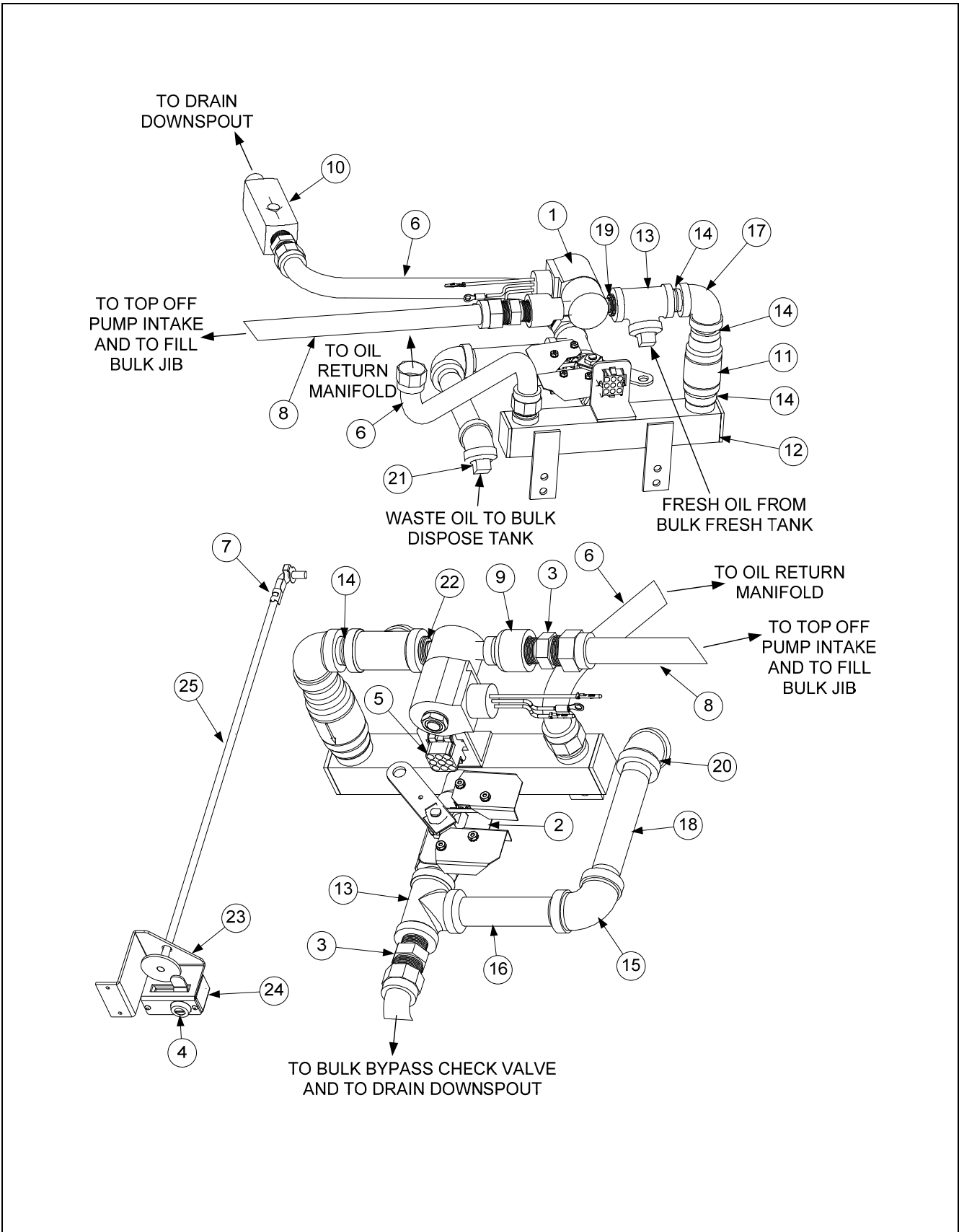

**1.11.1 Bulk Dispose, Fresh Oil Manifold and Accessories cont.**

ITEM	PART #	COMPONENT
√ 1	1066830	Solenoid Assembly
2	1080446	Valve, RTI Waste Assembly (see page 1-27 for parts)
3	8101668	Adaptor, Male 5/8" OD x 1/2"
4	8103587	Lock and Key, RTI Waste Handle
5	8075786	Harness, Bulk Oil
*	1085398SP	Bulk Oil Harness Pigtail
6	8101057	Flexline, 5/8" OD x 13-inch long
7	8090601	Clip, Clevis Left Rod End
8	8101069	Flexline, 5/8" OD x 29.50-inch long (used for 3, 4, and 5 battery)
	8101067	Flexline, 5/8" OD x 8.50-inch long (used for 2-battery)
9	8130555	Reducer, Bell Fitting, 1/2" to 1/4" NPT BM
10	8103531	Valve, Check 20 PSI RTI bypass
11	8104879	Valve, Check 1/2" NPT 4 PSI RTI Manifold
12	8103596	Manifold, RTI
13	8130003	Tee, 1/2" x 1/2" x 1/2" BM
14	8103738	Adaptor, Check Valve Close Nipple
15	8130062	Elbow, 1/2" Blk 90°
16	8130093	Nipple, 1/2" x 4-inch
17	8130062	Elbow, 1/2" BM 90°
18	8130261	Nipple, 1/2" x 5-inch NPT
19	8130304	Bushing, 1/2" x 1/4"
20	8130345	Elbow, 1/2 Blk 45°
21	8130629	Plug, 1/2" NPT Square Head
22	8130838	Nipple, 1/4" NPT
23	2205656	Brace, RTI Handle
24	2205657	Cover, RTI Handle
25	8237142	Handle, RTI Waste Pull

√ Recommended parts.

### 1.11.2 Bulk Dispose Waste Valve

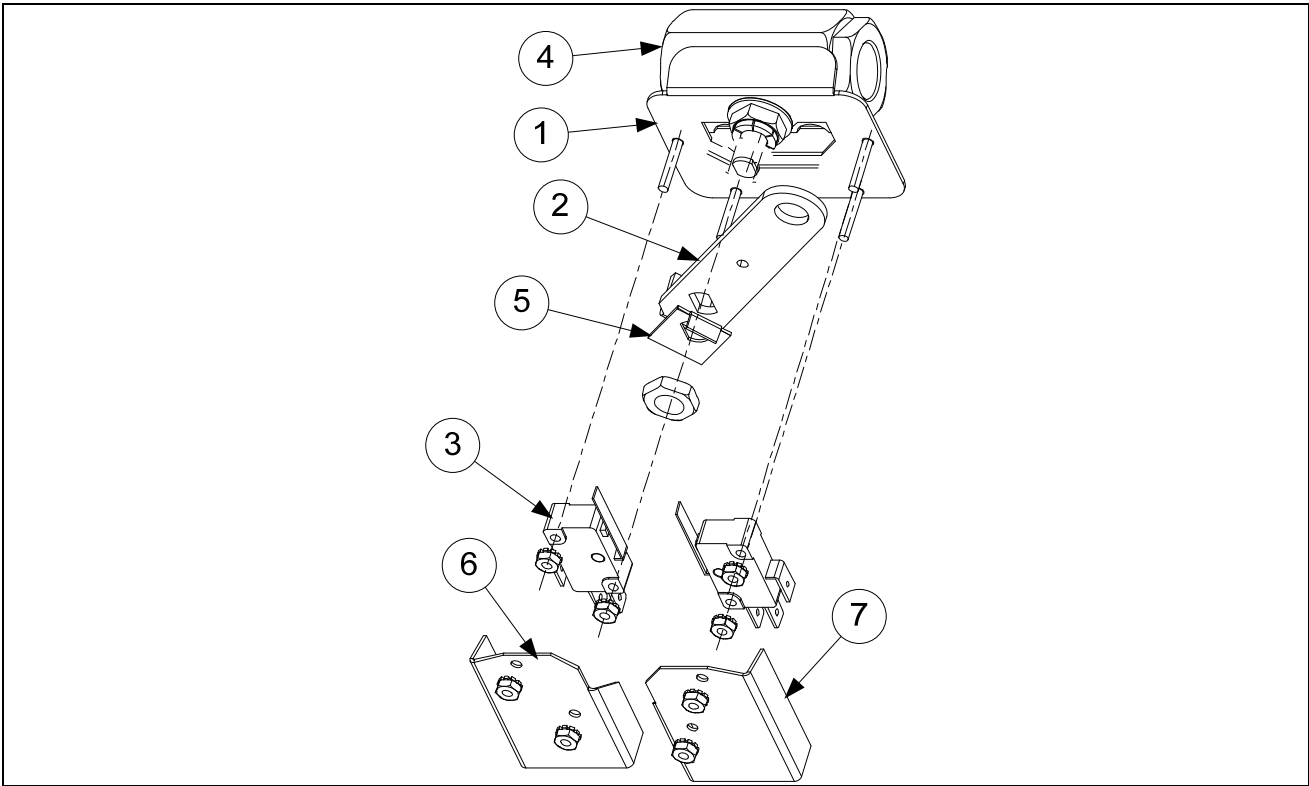

ITEM	PART #	COMPONENT
	1080446SP	Valve, Bulk Dispose Waste
1	1080445	Bracket, Bulk Waste Valve
2	2205615	Handle, Bulk Waste Valve
3	8074936	Microswitch, Gold Sealed
4	8100278	Valve, 1/2" Ball
5	9002935	Retainer, Nut Return Valve
6	9012348	Cover, DV Safety Switch
7	9022348	Cover, DV Safety Switch

## 1.12 Basket Lift Assembly and Associated Parts

### 1.12.1 Basket Lift Assembly and Associated Parts - From Sept. 2017 to Jan. 2019

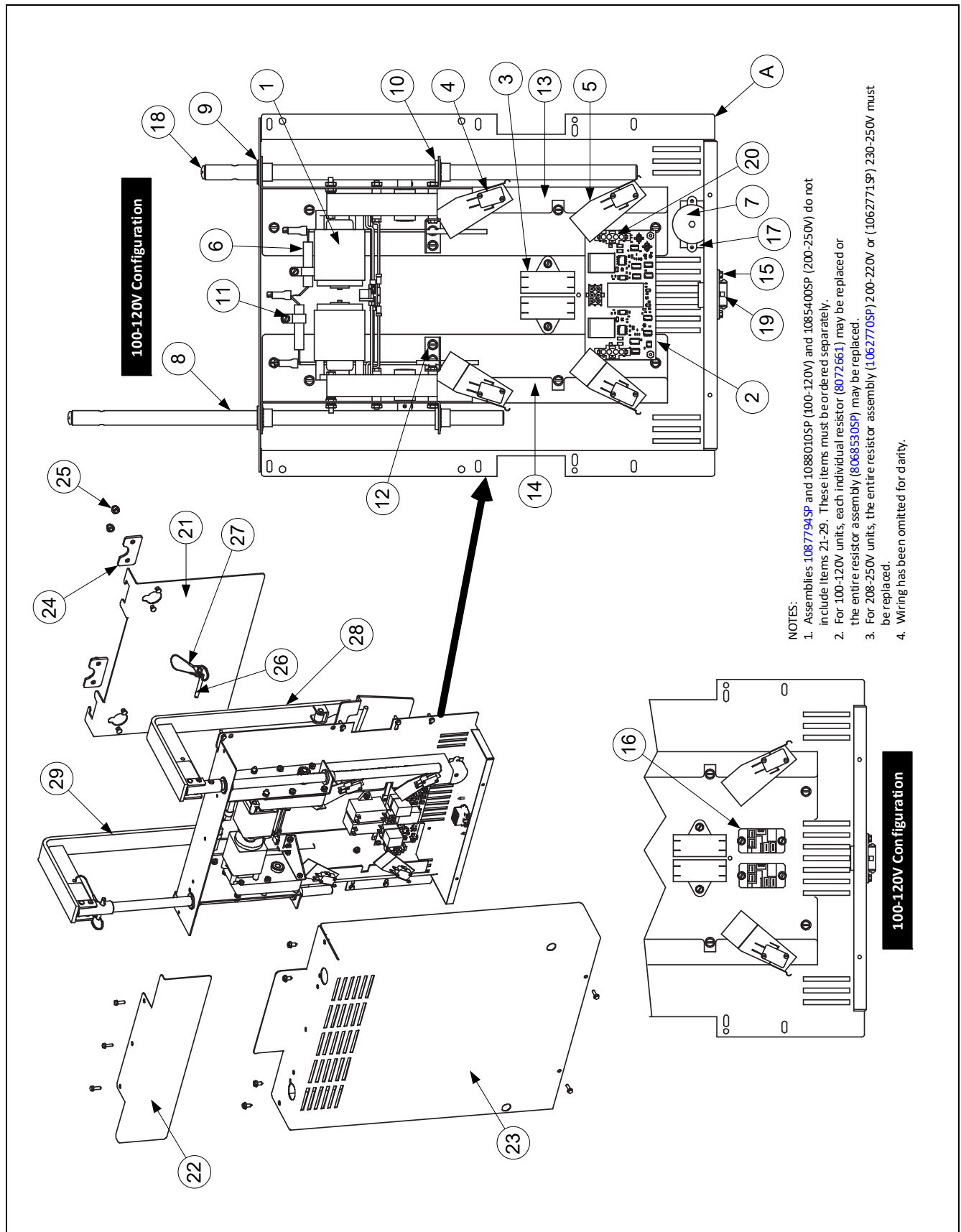

1.12.1 Basket Lift Assy and Associated Parts cont. From Sept. 2017 to Jan. 2019

ITEM	PART #	COMPONENT
		<b>Basket Lift Assemblies (see Note 1 in illustration)</b>
A	1087794SP	Basket Lift Assy, 100-120VAC <b>Reversing</b> (Items 1-20) shown <b>Use 8263479 for kit that includes items 1-29.</b>
B	1088010SP	Basket Lift Assy, 100-120VAC <b>Non-Reversing</b> (Items 1-20) partially shown – Arby's/General Market
	1085400SP	Basket Lift Assy, 200-250VAC <b>Non-Reversing</b> (Items 1-20) partially shown
C	1088400SP	Basket Lift Assy, 480-250VAC <b>Non-Reversing</b> (Items 1-20) partially shown
1	1084181SP	Motor Assy, 100-120VAC Modular Basket Lift
	1085031SP	Motor Assy, 208-250VAC Modular Basket Lift
2	4060070	PCB Assy, Basket Lift Reversing (only in 1087794SP assembly)
3	8072513	Capacitor, 12.5 µFd 330VAC
4	8072572	Microswitch
5	8120442	Insulation, Microswitch
6		Resistor Assy
	8068530SP	100-120V Modular Basket Lift (see <b>Note 2</b> in illustration)
	1062770SP	208-220VAC Modular Basket Lift
*	1062771SP	230-250VAC Modular Basket Lift
7	8103141	Sound Device
8	8104855	Rod, Modular BL w/Pin TB (use 8101012 for non-reversing)
9	8130035	Bushing, Bronze
10	8090082	Ring, Bushing Retainer
11	8090810	Clamp, Nylon
12	2209678	Gusset, Basket Lift Motor
13	2410330	Chassis, Left Basket Lift (use 2411379 for non-reversing)
14	2420330	Chassis, Right Basket Lift (use 2421379 for non-reversing)
15	2201415	Plate, Basket Lift Harness
16	8071683	Relay, 12VDC
17	8160862	Tape, 3M VHB 1.00 X 2.00
18	8090129	Screw, 1/4-20 X 5/8 Slotted Round Head
19	1087776	Harness, Reversing Modular BL
20	1087775	Harness, Reverse BL 4-Pin Connector
*	WIR1197	Wire Assy, Basket Lift Reverse 100-120VAC
*	WIR0166	Wire Assy, Basket Lift Reverse 200-250VAC (used in non-reverse also)
21	1087768	Guide, B/L Arm Taco Bell
	1087767	Guide, B/L Arm non-Taco Bell
	1087760	Guide, B/L Arm General Market
22	2401693	Shield, Rear Modular B/L Cover
23	2401694	Cover, FQ4000 Modular B/L (use 2601846 non-reversing)
24	2601474	Cover, Basket Hanger Rivet B/L
25	8090047	Nut, Cap ¼" -20
26	8104852	Pin, ¼" X 1-5/16" Quick Release
27	8104854	Lanyard, w/Ring
28	8239432	Arm, Left Basket Lift Taco Bell (use 8239445 for General Market) (use 8239462 for Arby's)
29	8239433	Arm, Right Basket Lift Taco Bell (use 8239446 for General Market) (use 8239497 for Arby's)

\* Not illustrated.

### 1.12.2 Basket Lift Assy and Associated Parts - 480V - After Feb. 2019 (Modular)

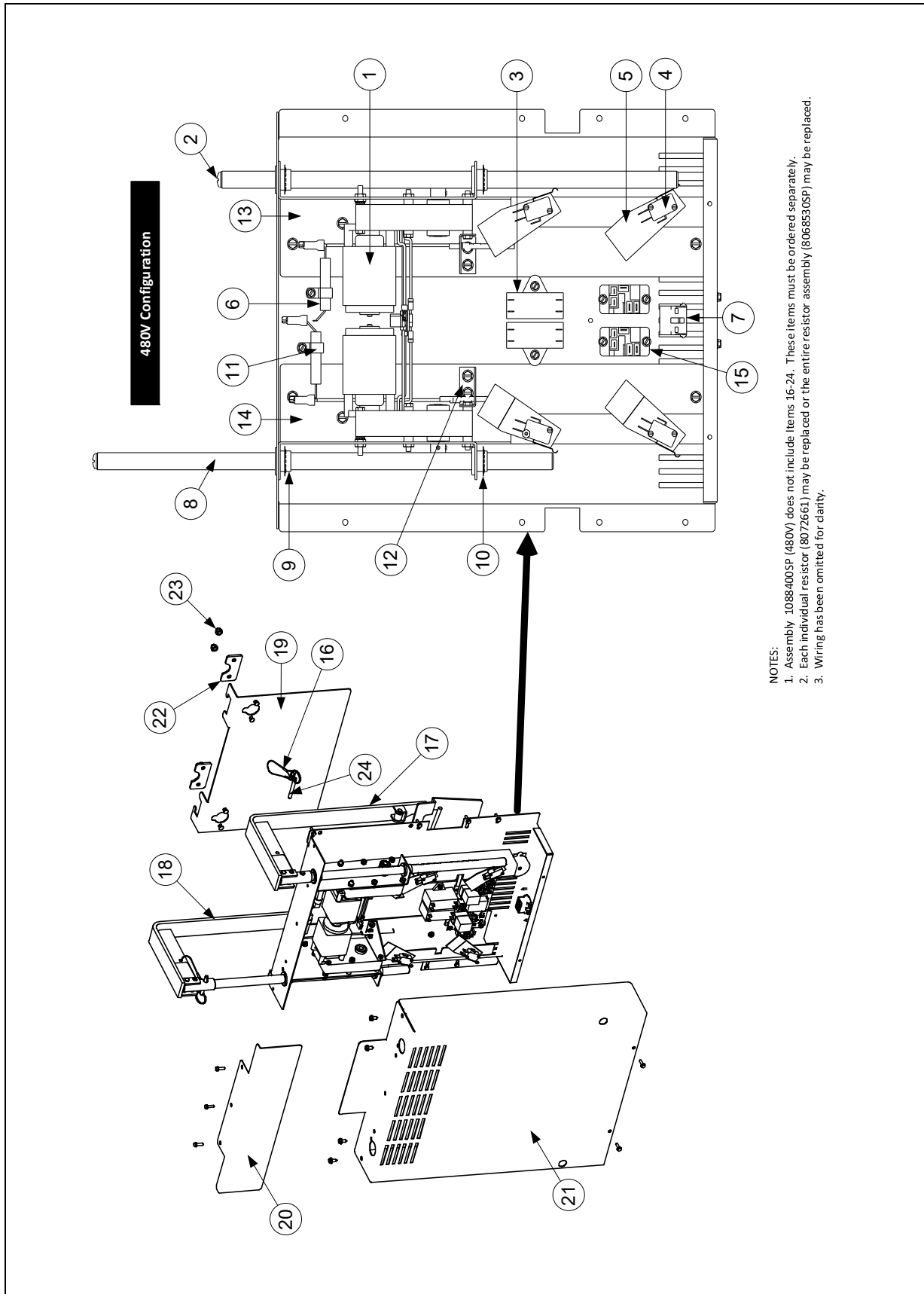

**1.12.2 Basket Lift Assy and Associated Parts - 480V - After Feb. 2019 (Modular)**

ITEM	PART #	COMPONENT
		<b>Basket Lift Assemblies</b> (see <b>Note 1</b> in illustration)
A	1088400SP	Basket Lift Assy, 480VAC (Items 1-15)
1	1084181SP	Motor Assy, 120VAC Modular Basket Lift
2	8090129	Screw, 1/4-20 X 5/8 Slotted Round Head
3	8072513	Capacitor, Motor Run 12.5 MFD 330VAC
4	8072572	Microswitch
5	8120442	Insulation, Microswitch Box
6	8068530SP	Resistor Assembly (see <b>Note 2</b> in illustration)
7	8070159	Connector, 12 Pin Plug Housing
8	8101012	Rod, Modular BL
9	8130035	Bushing, Bronze
10	8090082	Ring, Bushing Retainer ¾ Truarc
11	8090810	Clamp, Nylon
12	2209678	Gusset, Reversing Basket Lift Motor
13	2229461	Chassis, FPEL Basket Lift
14	2219461	Chassis, FPEL Basket Lift
15	8071683	Relay, 12VDC
16	8104854	Lanyard, w/Ring
17	8238844	Arm, Left (Illustration May Slightly Differ)
18	8238845	Arm, Right (Illustration May Slightly Differ)
19	1087760	Guide, B/L Arm (Illustration May Slightly Differ)
20	2401693	Shield, Rear Modular B/L Cover
21	2601709	Cover, Modular B/L (Illustration May Slightly Differ)
22	2601474	Cover, Basket Hanger Rivet B/L
23	8090047	Nut, Cap ¼" -20
24	8104852	Pin, ¼" X 1-5/16" Quick Release

### 1.12.3 Basket Lift Assy and Associated Parts - 200V-250V - After April 2014 (Modular)

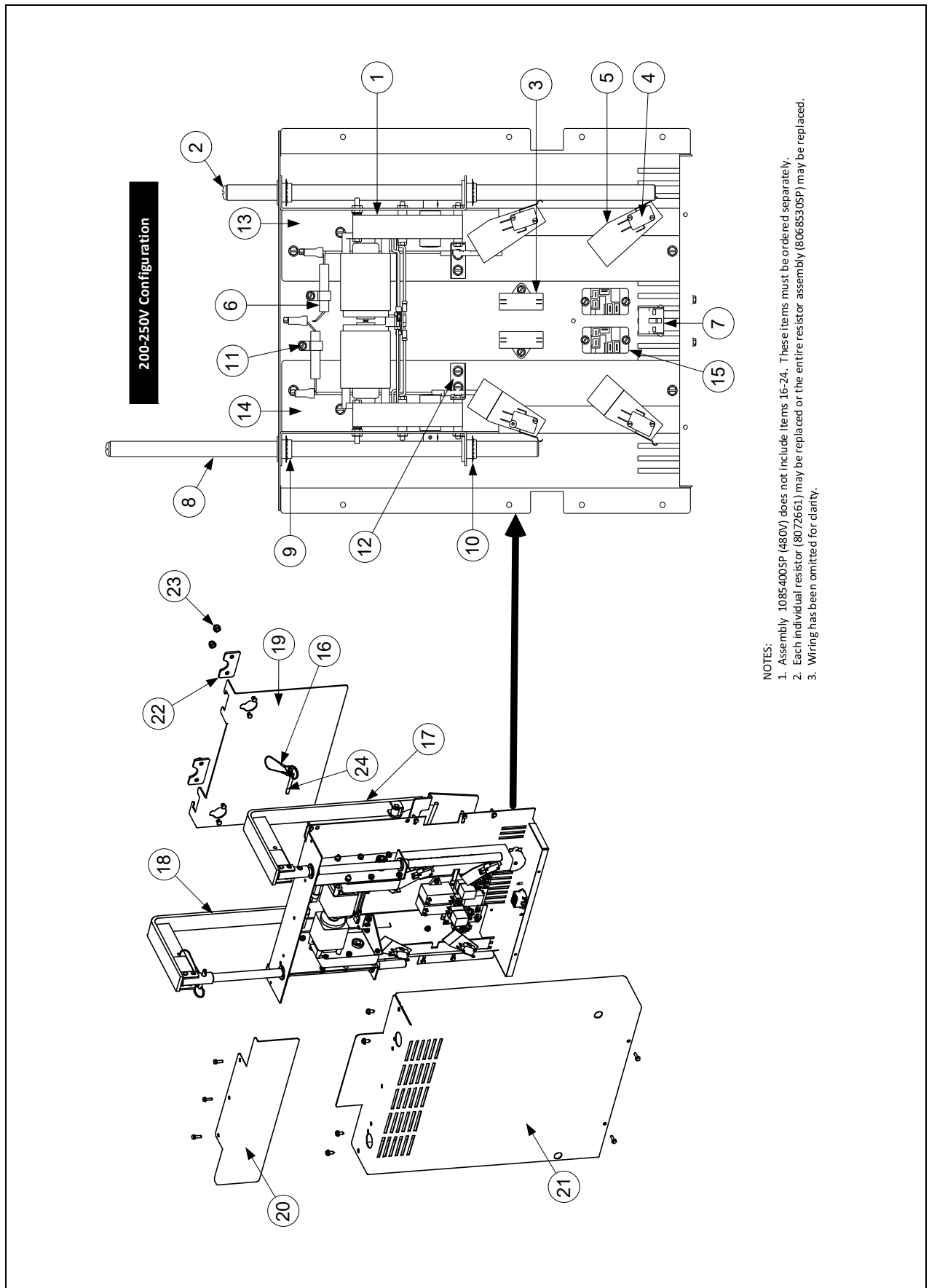

- NOTES:**
- 1. Assembly 1085400SP (480V) does not include Items 16-24. These items must be ordered separately.
  - 2. Each individual resistor (8072661) may be replaced or the entire resistor assembly (8068530SP) may be replaced.
  - 3. Wiring has been omitted for clarity.

### 1.12.3 Basket Lift Assy and Associated Parts – 200V-250V - After April 2014 (Modular)

ITEM	PART #	COMPONENT
		<b>Basket Lift Assemblies</b> (see <b>Note 1</b> in illustration)
A	1085400SP	Basket Lift Assy, 200-250VAC (Items 1-15)
1	1085031SP	Motor Assy, 208-250VAC Modular Basket Lift w/Gear
2	8090129	Screw, 1/4-20 X 5/8 Slotted Round Head
3	8076253	Capacitor, Motor Run 4.0 MFD 440VAC
4	8072572	Microswitch
5	8120442	Insulation, Microswitch Box
6	8068530SP	Resistor Assembly (see <b>Note 2</b> in illustration)
7	8070159	Connector, 12 Pin Plug Housing
8	8101012	Rod, Modular BL
9	8130035	Bushing, Bronze
10	8090082	Ring, Bushing Retainer 3/4 Truarc
11	8090810	Clamp, Nylon
12	2209678	Gusset, Reversing Basket Lift Motor
13	2229461	Chassis, FPEL Basket Lift
14	2219461	Chassis, FPEL Basket Lift
15	8071683	Relay, 12VDC
16	8104854	Lanyard, w/Ring
17	8238844	Arm, Left (Illustration May Slightly Differ)
18	8238845	Arm, Right (Illustration May Slightly Differ)
19	1087760	Guide, B/L Arm (Illustration May Slightly Differ)
20	2401693	Shield, Rear Modular B/L Cover
21	2601709	Cover, Modular B/L (Illustration May Slightly Differ)
22	2601474	Cover, Basket Hanger Rivet B/L
23	8090047	Nut, Cap 1/4" -20
24	8104852	Pin, 1/4" X 1-5/16" Quick Release

### 1.13 Oil Quality Sensor (OQS) and Associated Parts

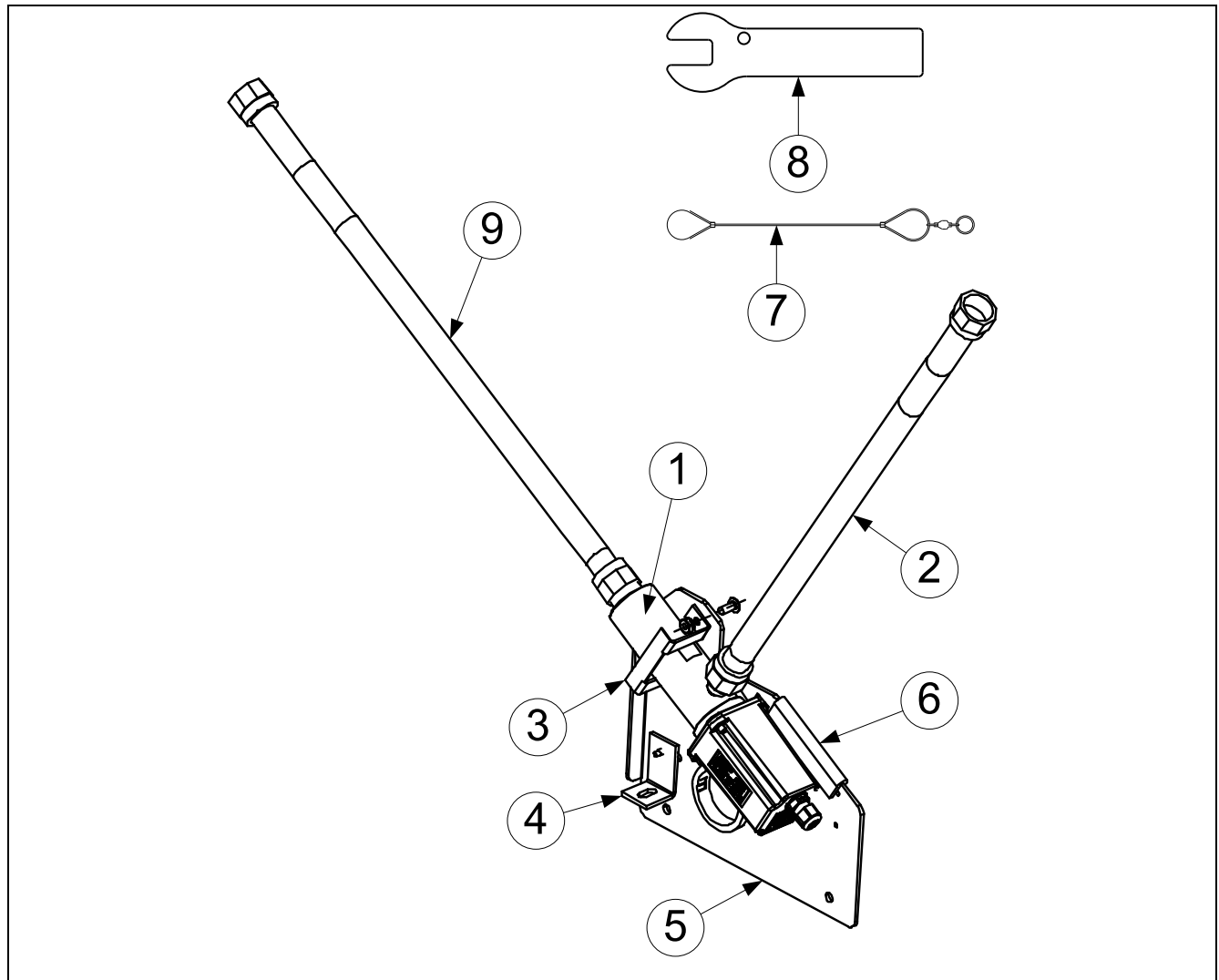

ITEM	PART #	COMPONENT
	8263493	Kit, OQS FilterQuick Elec (Kit to add to existing FQ-T Electric Fryers)
1	<a href="#">8263292</a>	Sensor, FilterQuick OQS Replacement
2	<a href="#">8101369</a>	Flexline, 5/8" OD x 17.50-inch
3	<a href="#">2401385</a>	Retainer, OQS Sensor FQ
4	2401386	Brace, OQS Sensor Mount
5	2401438	Mount, OQS Sensor FQ
6	8122524	Insulation
7	<a href="#">8104167</a>	Lanyard, In-Line Filter
8	<a href="#">2401086</a>	Wrench, Pre-Filter Cap
9	<a href="#">8101055</a>	Flexline, 5/8" OD x 11.50-inch
*	8238990	Wrench, 1-1/16" (27mm)
*	<a href="#">8238991</a>	Wrench, 1-1/16" (27mm) crows foot

\* Not illustrated.

### 1.14 Wiring Connectors, Pin Terminals and Power Cords



ITEM	PART #	COMPONENT
<b>Power Cords</b>		
<b>DELTA</b>		
*	8073834	Cable, 3 Phase, 4 Wire, 96" 8 Gauge, Plug- None
*	8074669	Cable, 3 Phase, 4 Wire, 96" 6 Gauge, Plug- None
*	8074668	Cordset, 3 Phase, 4 Wire, 96" 6 Gauge, Plug- Arrow Hart 8462N
*	8073817	Cordset, 3 Phase, 4 Wire, 96" 6 Gauge, Plug- Arrow Hart 8462N, Hubbell HBL-8461C
*	8075625	Cordset, 3 Phase, 4 Wire, 113" 4 Gauge, Plug- Hubbell HBL-8462C
*	8075854	Cord, 3 Phase, 4 Wire, 113" 4 Gauge, Plug- None
<b>WYE</b>		
*	8073836	Cordset, FPP European Power, 5 Wire, 92", 10 Gauge, Plug- Hubbell C532P6S
*	8073835	Cable, Export, 5 Wire, 92", 10 Gauge, Plug- None
*	8073838	Cable, Export, 5 Wire, 147", 10 Gauge, Plug- None
*	8074979	Cordset, FPP European Power, 5 Wire, 92", 10 Gauge, Plug- Mennekes 532P6-14
*	8074143	Cable, Export, 5 Wire, 118", 10 Gauge, Plug- None
*	8073976	Cable, Export, 5 Wire, 177", 10 Gauge, Plug- None
*	8073977	Cable, Export China, 5 Wire, 165", 10 Gauge, Plug- None
*	8074005	Cable, Export Australia, 5 Wire, 104", 10 Gauge, Plug- None
<b>Connectors and Tools</b>		
1	8071068	2-Pin Female
2	8070158	6-Pin Female
3	8070156	9-Pin Female
5	8070159	12-Pin Female
5	8070875	15-Pin Female
6	8071067	2-Pin Male
7	8070157	6-Pin Male
8	8070155	9-Pin Male
9	8070160	12-Pin Male
10	8070804	15-Pin Male
11	8261341	Terminal, Female Split Pin (Pkg of 25)
12	8261342	Terminal, Male Split Pin (Pkg of 25)
13	8072518	Plug, Mate-N-Lock (Dummy Pin)
14	8070928	Extract Tool Pin Pusher
15	8064855	Pin Pusher Screwdriver Assembly
16	2302345	SMT Pin Extractor
*	8074660PK	SMT Pin Service Repair Kit

\* Not illustrated.

# 1.15 FilterQuick™ FQE30-T Series Simplified Wiring

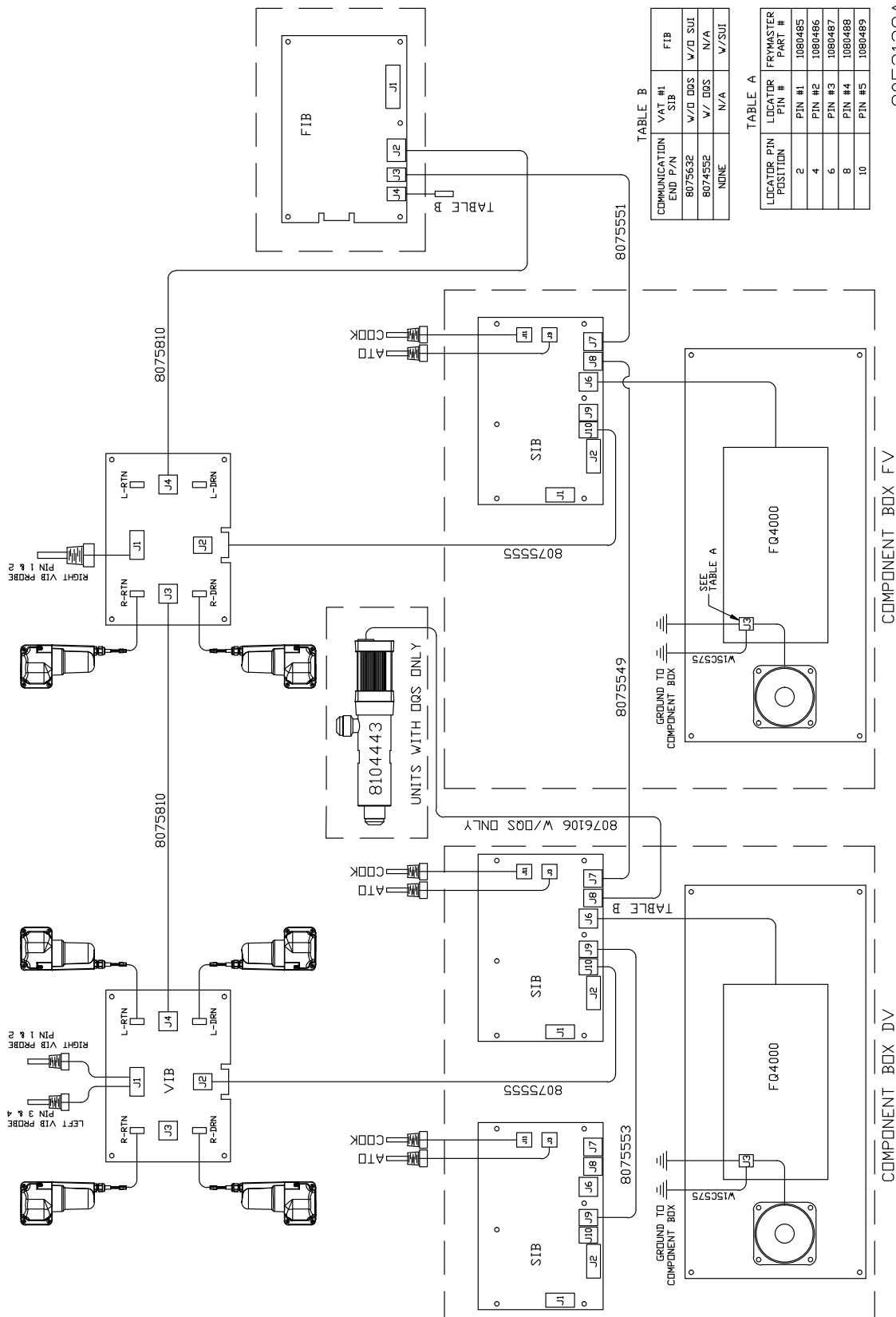

TABLE B

COMMUNICATION END P/N	VAT #1 SIB	FIB
8075632	W/O DQS	W/O SUI
8074552	W/ DQS	N/A
NONE	N/A	W/SUI

TABLE A

LOCATOR PIN POSITION	LOCATOR PIN #	FRYMASTER PART #
2	PIN #1	1080485
4	PIN #2	1080486
6	PIN #3	1080487
8	PIN #4	1080488
10	PIN #5	1080489

8052138A

# *Frymaster*<sup>®</sup>

FRYMASTER  
8700 LINE AVENUE, SHREVEPORT, LA 71106-6800

800-551-8633  
318-865-1711  
[WWW.FRYMASTER.COM](http://WWW.FRYMASTER.COM)  
EMAIL: [FRYSERVICE@WELBILT.COM](mailto:FRYSERVICE@WELBILT.COM)



Welbilt offers fully-integrated kitchen systems. Welbilt's portfolio of award-winning brands includes Cleveland™, Convotherm®, Crystal Tips®, Dean®, Delfield®, Fabristeel®, Frymaster®, Garland®, Inducs®, Koldtech®, Kolpak®, Lincoln®, McCann's™, Merco®, Merrychef®, Multiplex®, RDI®, SerVend™, SunFire®, U.S. Range™, and WMaxx™. Supported by service brands: FitKitchen®, kitchen systems; and KitchenConnect®, cloud-based open platform.

*Bringing innovation to the table* • [welbilt.com](http://welbilt.com)

©2024 Frymaster LLC. except where explicitly stated otherwise. All rights reserved. Continuing product improvement may necessitate change of specifications without notice.

Part Number FRY\_P\_8197466 02/2024