

# Frymaster®

Your Growth Is Our Goal

## FilterQuick™ FQE30-T Electric Fryer

### Wiring Diagrams

This manual is updated as new information and models are released. Visit our website for the latest manual.



#### FOR YOUR SAFETY

Do Not Store or use gasoline or other flammable vapors and liquids in the vicinity of this or any other appliance.

**⚠ CAUTION**

**READ THE INSTRUCTIONS BEFORE USING THE FRYER.**



8 1 9 7 4 6 4

Part Number: FRY\_D\_8197464 08/2023

Original Instructions



** DANGER**

**Improper installation, adjustment, maintenance or service, and unauthorized alterations or modifications can cause property damage, injury, or death. Read the installation, operating, and service instructions thoroughly before installing or servicing this equipment.**

** DANGER**

**This fryer has a power cord (three-phase) for each frypot. Prior to movement, testing, maintenance and any repair on your Frymaster fryer; disconnect ALL electrical power cords from the electrical power supply.**

# FILTERQUICK™ FQE30-T ELECTRIC FRYER

## Table of Contents

---

### SECTION 1: Wiring Diagrams

1.1	FQE30-T Domestic US, Non-CE Wiring – Current - After 06-2022.....	1-1
1.1.B	FQE30-T Domestic US, Non-CE Wiring – Prior to 07/2022 .....	1-2
1.2	FQE30-T CE/Australia Wiring – Current – After 06/2022.....	1-3
1.2.B	FQE30-T CE/Australia Wiring – Prior to 07/2022 .....	1-4
1.3	FQE30-T Simplified Communication Wiring.....	1-5
1.4	Contactor Box-Delta Configuration .....	1-6
1.5	Contactor Box-WYE Configuration.....	1-7
1.6	Solid Shortening Melting Unit Wiring .....	1-8
1.7	Basket Lift Wiring Diagram – <i>(From Sept. 2017 to Jan. 2019)</i> .....	1-9
1.8	Basket Lift Wiring Diagram – <i>(480V – After Feb. 2019) (Modular)</i> .....	1-10
1.9	Basket Lift Wiring Diagram – <i>(200V-250V – After April 2014) (Modular)</i> .....	1-11









# 1.3 FQ30-T Simplified Communication Wiring

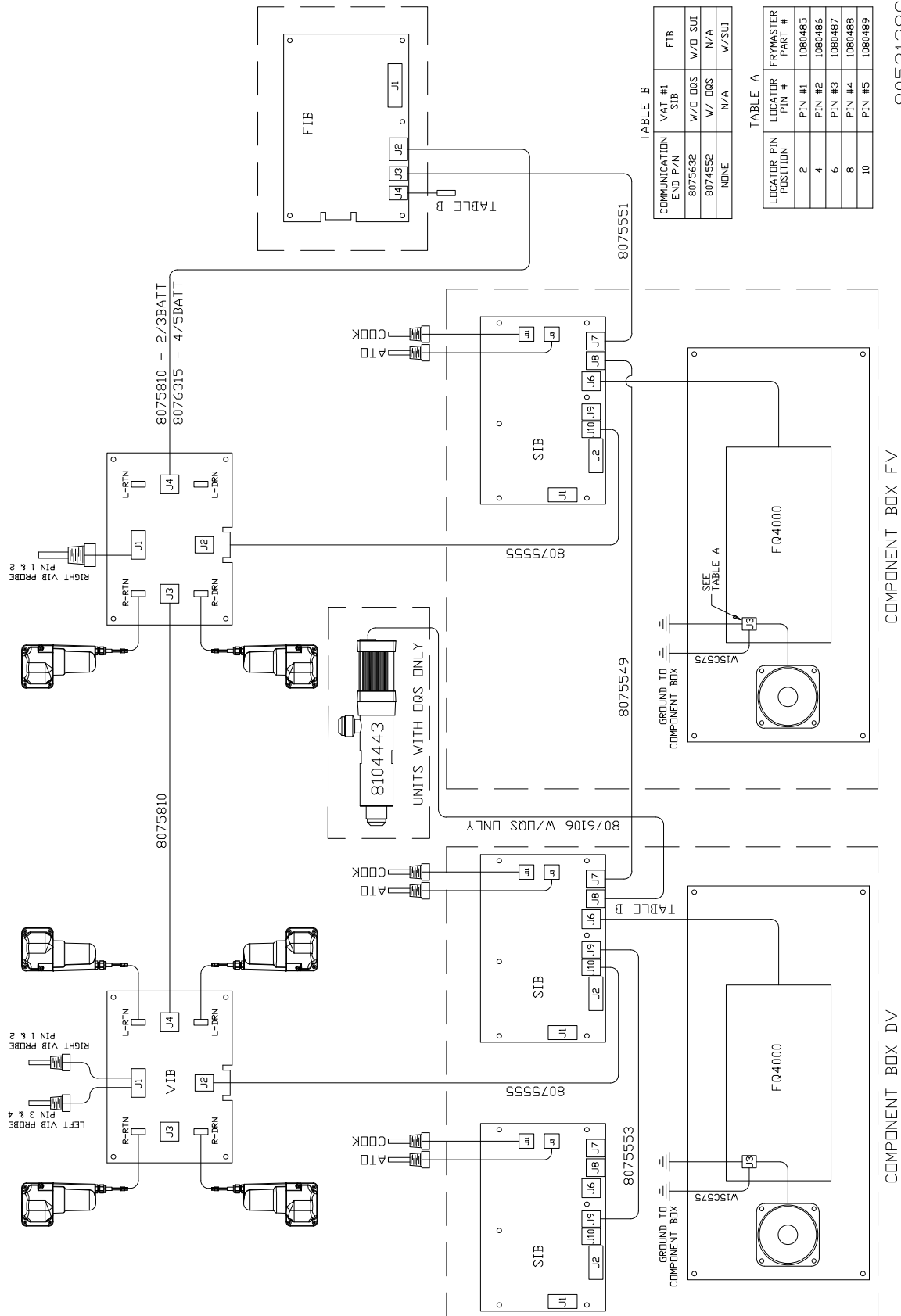

TABLE B

COMMUNICATION END P/N	VAT #1 SIB	FIB
8075632	W/O DQS	W/O SUI
8074552	W/ DQS	N/A
NONE	N/A	W/SUI

TABLE A

LOCATOR PIN POSITION	LOCATOR PIN #	FRYMASTER PART #
2	PIN #1	1080485
4	PIN #2	1080486
6	PIN #3	1080487
8	PIN #4	1080488
10	PIN #5	1080489

8052138C

# 1.4 Contactor Box - Delta Configuration

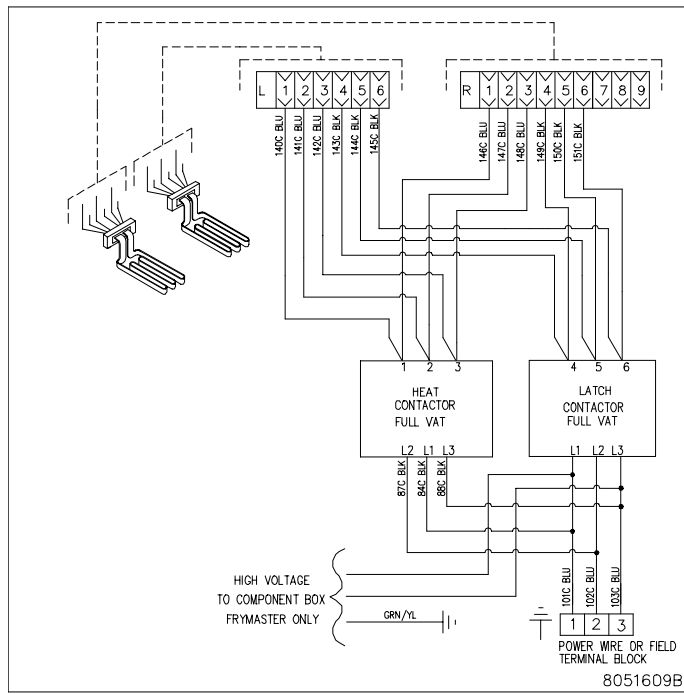

**FULL VAT**

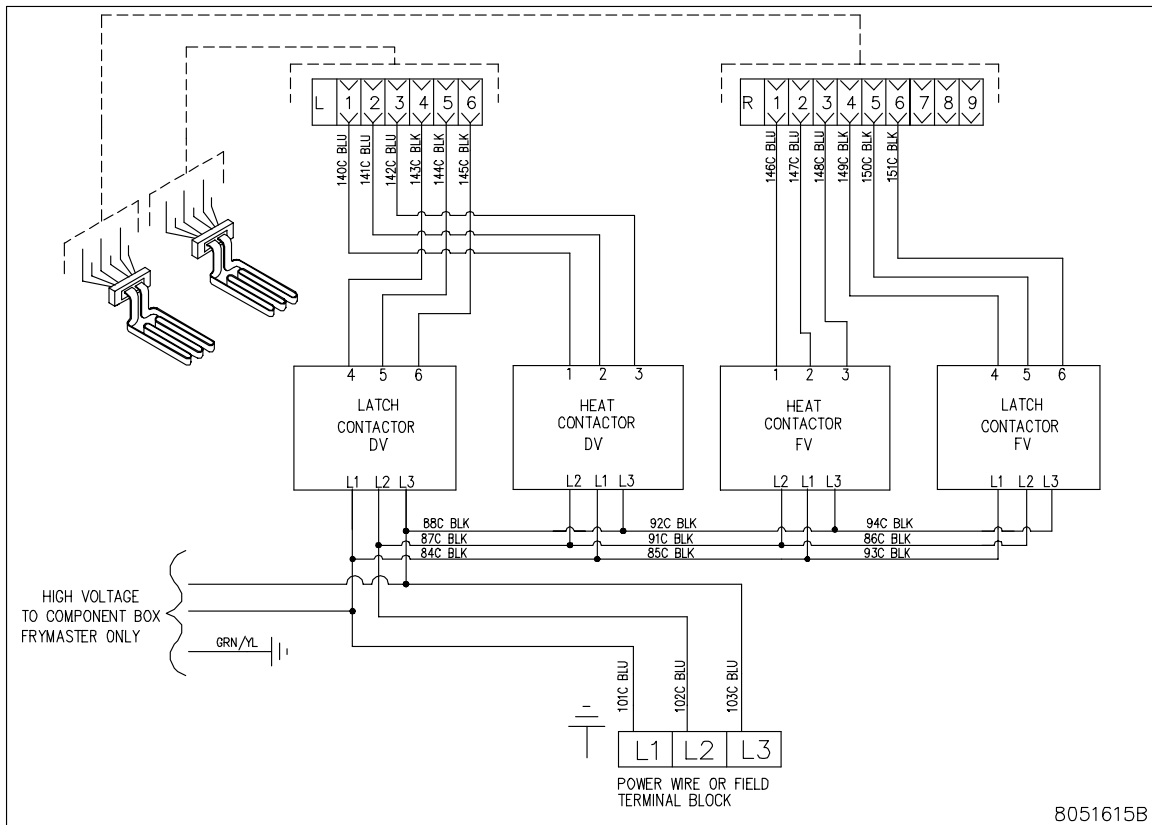

**DUAL VAT**

# 1.5 Contactor Box - WYE Configuration

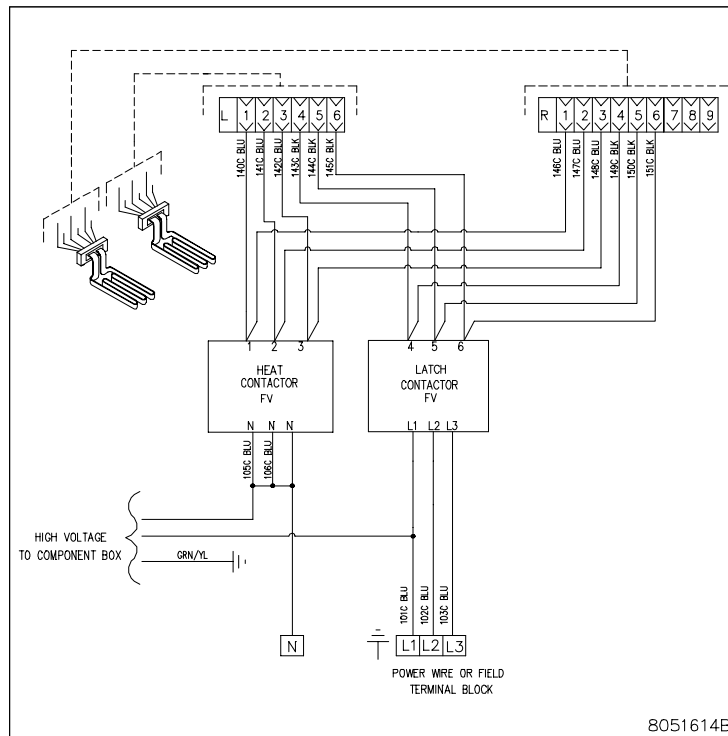

**FULL VAT**

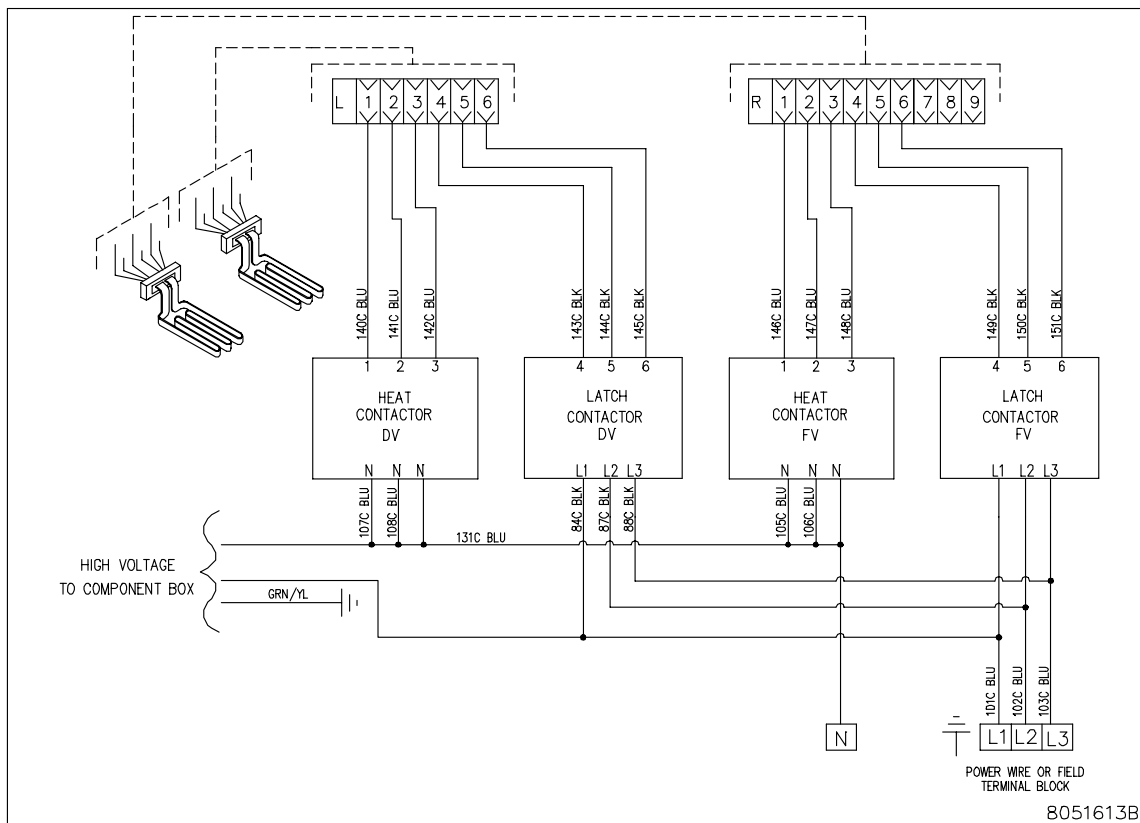

**DUAL VAT**



# 1.7 Basket Lift Wiring Diagram - From Sept. 2017 to Jan. 2019

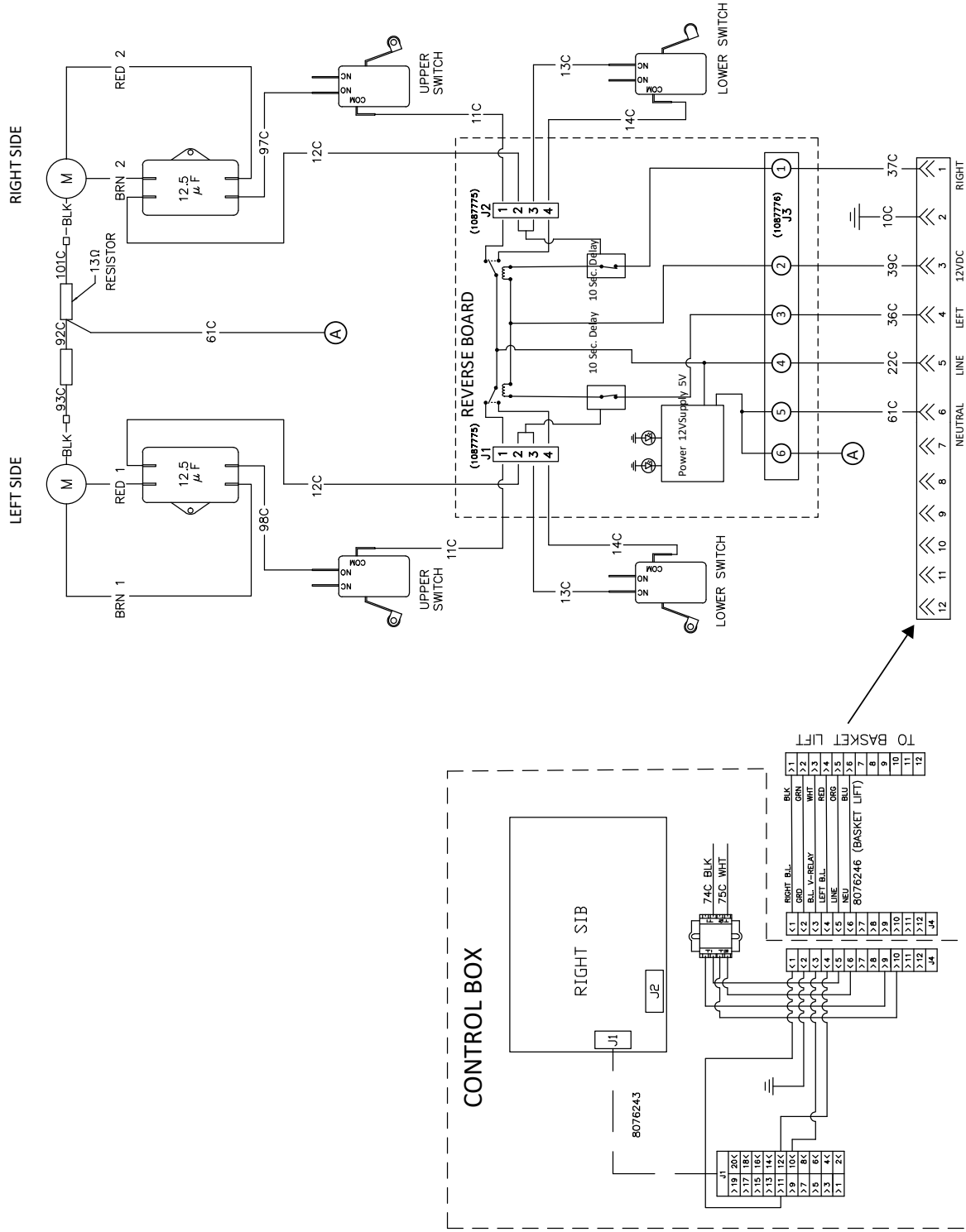

REFERENCES TO LEFT AND RIGHT ARE FROM THE FRONT OF THE FRYER

# 1.8 Basket Lift Wiring Diagram - 480V - After Feb. 2019 (Modular)

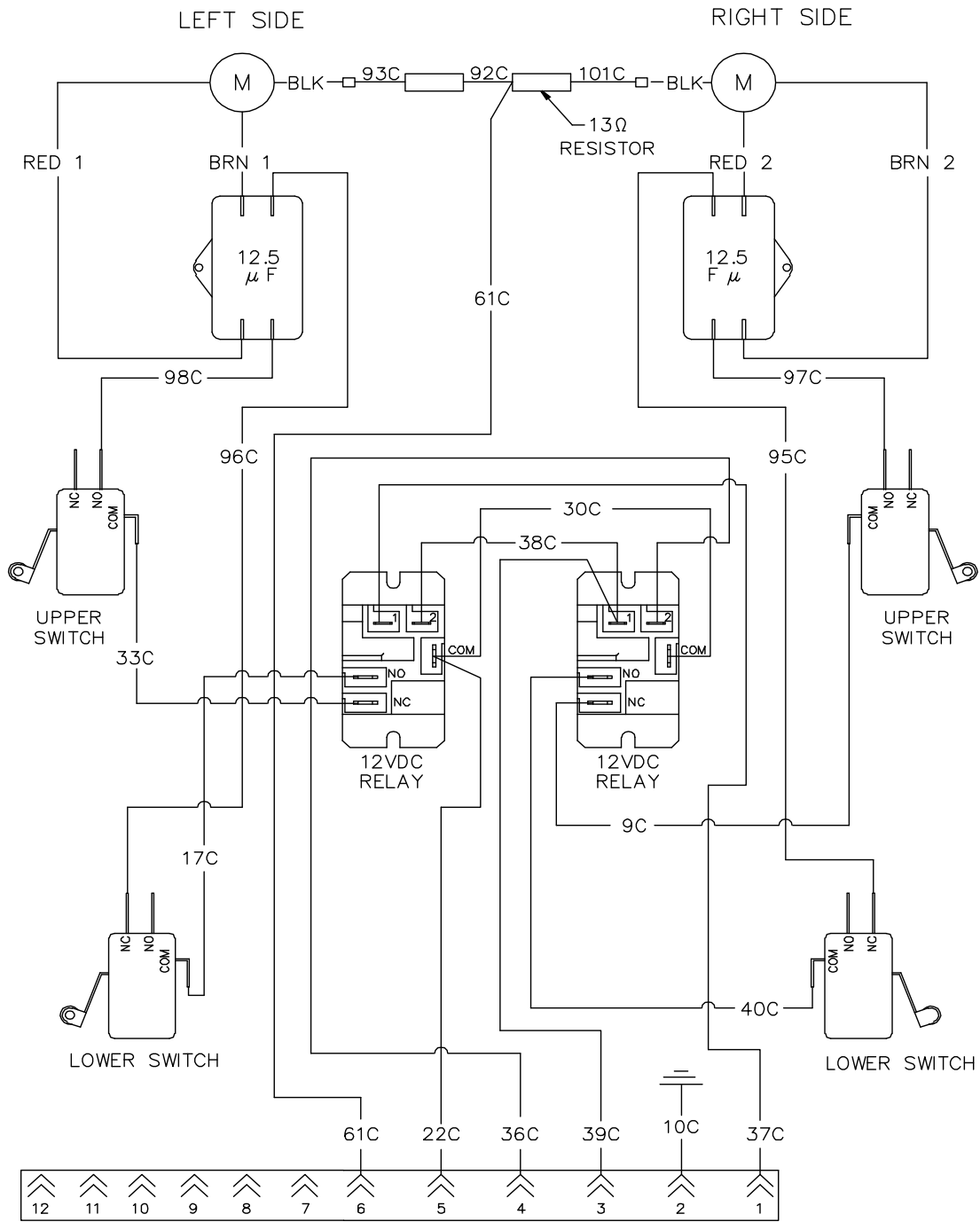

REFERENCES TO LEFT & RIGHT ARE FROM THE REAR OF THE FRYER

8051924C

# 1.9 Basket Lift Wiring Diagram - 200V-250V - After April 2014 (Modular)

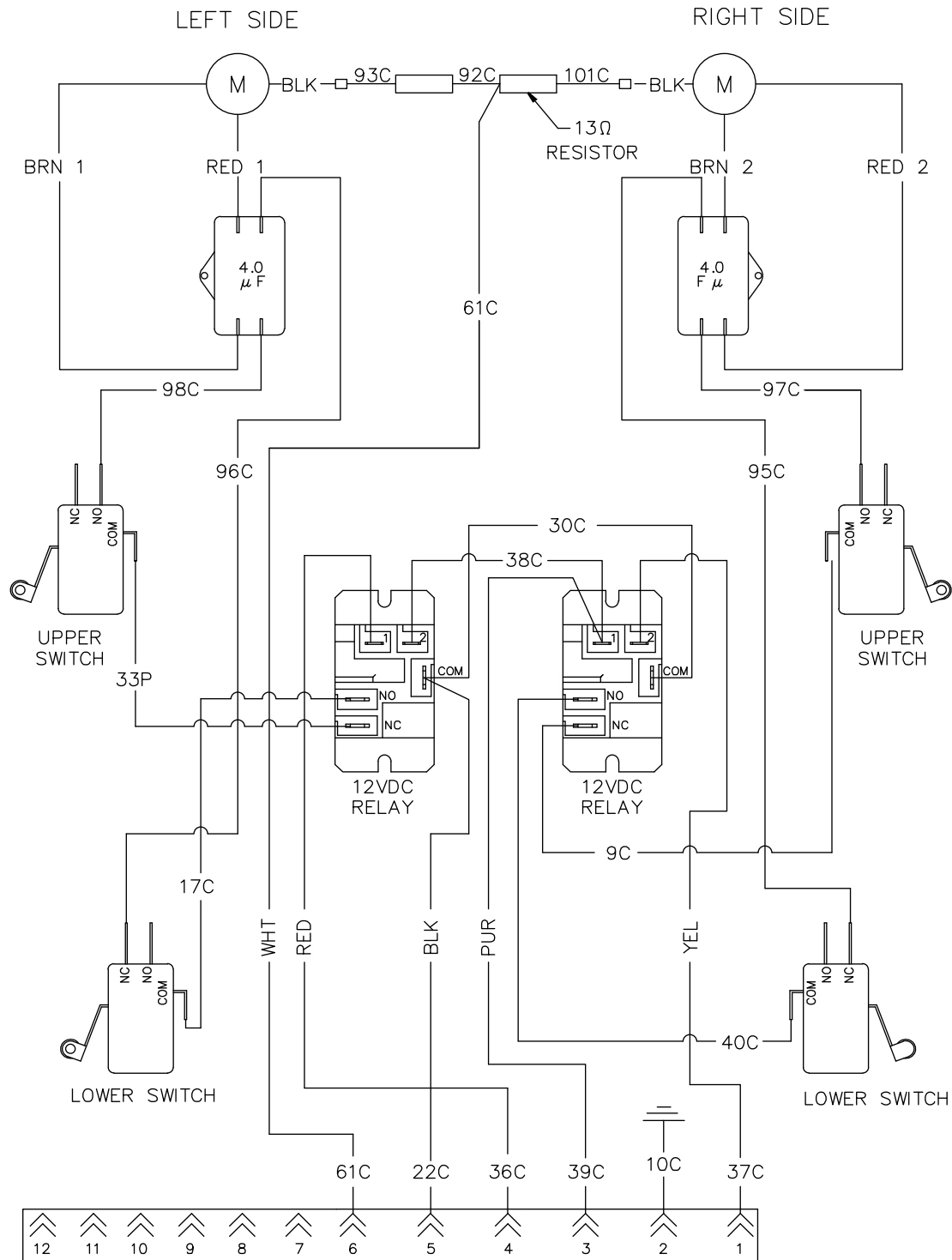

REFERENCES TO LEFT & RIGHT ARE FROM THE REAR OF THE FRYER

8051964B

**THIS PAGE INTENTIONALLY LEFT BLANK**

# *Frymaster*<sup>®</sup>

FRYMASTER  
8700 LINE AVENUE, SHREVEPORT, LA 71106-6800

800-551-8633  
318-865-1711  
[WWW.FRYMASTER.COM](http://WWW.FRYMASTER.COM)  
EMAIL: [FRYSERVICE@WELBILT.COM](mailto:FRYSERVICE@WELBILT.COM)



Welbilt offers fully-integrated kitchen systems. Welbilt's portfolio of award-winning brands includes Cleveland™, Convotherm®, Crystal Tips®, Dean®, Delfield®, Fabristeel®, Frymaster®, Garland®, Inducs®, Koldtech®, Kolpak®, Lincoln®, McCann's™, Merco®, Merrychef®, Multiplex®, RDI®, SerVend™, SunFire®, U.S. Range™, and WMaxx™. Supported by service brands: FitKitchen®, kitchen systems; and KitchenConnect®, cloud-based open platform.

*Bringing innovation to the table* • [welbilt.com](http://welbilt.com)

©2023 Frymaster LLC. except where explicitly stated otherwise. All rights reserved. Continuing product improvement may necessitate change of specifications without notice.

Part Number FRY\_D\_8197464 08/2023