

Frymaster[®]

Your Growth Is Our Goal

FilterQuick[™] FQG30-T

Gas Fryer

Service Manual

This manual is updated as latest information and models are released. Visit our website for the latest manual.



FOR YOUR SAFETY

Do Not Store or use gasoline or other flammable vapors and liquids in the vicinity of this or any other appliance.



Part Number: FRY_SM_8197477 10/2023



NOTICE

IF, DURING THE WARRANTY PERIOD, THE CUSTOMER USES A PART FOR THIS FRYMASTER DEAN EQUIPMENT OTHER THAN AN UNMODIFIED NEW OR RECYCLED PART PURCHASED DIRECTLY FROM FRYMASTER DEAN, OR ANY OF ITS FACTORY AUTHORIZED SERVICERS, AND/OR THE PART BEING USED IS MODIFIED FROM ITS ORIGINAL CONFIGURATION, THIS WARRANTY WILL BE VOID. FURTHER, FRYMASTER DEAN AND ITS AFFILIATES WILL NOT BE LIABLE FOR ANY CLAIMS, DAMAGES OR EXPENSES INCURRED BY THE CUSTOMER WHICH ARISE DIRECTLY OR INDIRECTLY, IN WHOLE OR IN PART, DUE TO THE INSTALLATION OF ANY MODIFIED PART AND/OR PART RECEIVED FROM AN UNAUTHORIZED SERVICER.

NOTICE

This appliance is intended for professional use only and is to be operated by qualified personnel only. A Frymaster Authorized Servicer (FAS) or other qualified professional should perform installation, maintenance, and repairs. Installation, maintenance, or repairs by unqualified personnel may void the manufacturer's warranty. See Chapter 1 of this manual for definitions of qualified personnel.

NOTICE

This equipment must be installed in accordance with the appropriate national and local codes of the country and/or region in which the appliance is installed. See NATIONAL CODE REQUIREMENTS in Chapter 2 of this manual for specifics.

NOTICE TO U.S. CUSTOMERS

This equipment is to be installed in compliance with the basic plumbing code of the Building Officials and Code Administrators International, Inc. (BOCA) and the Food Service Sanitation Manual of the U.S. Food and Drug Administration.

NOTICE

Drawings and photos used in this manual are intended to illustrate operational, cleaning and technical procedures and may not conform to onsite management operational procedures.

NOTICE TO OWNERS OF UNITS EQUIPPED WITH CONTROLLERS

U.S.

This device complies with Part 15 of the FCC rules. Operation is subject to the following two conditions: 1) This device may not cause harmful interference, and 2) This device must accept any interference received, including interference that may cause undesired operation. While this device is a verified Class A device, it has been shown to meet the Class B limits.

CANADA

This digital apparatus does not exceed the Class A or B limits for radio noise emissions as set out by the ICES-003 standard of the Canadian Department of Communications.
Cet appareil numérique n'émet pas de bruits radioélectriques dépassant les limites de classe A et B prescrites dans la norme NMB-003 édictée par le Ministre des Communications du Canada.

⚠ WARNING

After installation of a gas fryer and after any maintenance to the gas system of a gas fryer-manifold, valve, burners, etc. - check for gas leaks at all connections. Apply a thick soapy solution to all connections and ensure there are no bubbles. There should be no smell of gas.

⚠ DANGER

Improper installation, adjustment, maintenance or service, and unauthorized alterations or modifications can cause property damage, injury, or death. Read the installation, operating, and service instructions thoroughly before installing or servicing this equipment.

⚠ DANGER

Adequate means must be provided to limit the movement of this appliance without depending upon the gas line connection. All fryers equipped with casters must be stabilized by installing restraining chains. If a flexible gas line is used, an additional restraining cable must be connected at all times when the fryer is in use.

⚠ DANGER

The front ledge of this appliance is not a step! Do not stand on the appliance. Serious injury can result from slips or contact with the hot oil.

⚠ DANGER

Do not store or use gasoline or other flammable liquids or vapors in the vicinity of this or any other appliance.

⚠ DANGER

This product contains chemicals known to the state of California to cause cancer and/or birth defects or other reproductive harm.

Operation, installation, and servicing of this product could expose you to airborne particles of glasswool or ceramic fibers, crystalline silica, and/or carbon monoxide. Inhalation of airborne particles of glasswool or ceramic fibers is known to the State of California to cause cancer. Inhalation of carbon monoxide is known to the State of California to cause birth defects or other reproductive harm.

⚠ WARNING

Use caution and wear appropriate safety equipment to avoid contact with hot oil or surfaces that may cause severe burns or injury.

⚠ DANGER

Keep all items out of drains. Closing actuators may cause damage or injury.

Table of Contents

Section 1: Service Procedures

1.1	FQ4000 Menu Summary Trees.....	1-1
1.1.1	FQ4000 Menu Tree General Market (Non-Taco Bell)	1-1
1.1.2	FQ4000 Information Statistics Menu Tree General Market (Non-Taco Bell).....	1-2
1.1.3	FQ4000 Menu Tree Taco Bell.....	1-3
1.1.4	FQ4000 Information Statistics Menu Tree Taco Bell	1-4
1.2	FQ4000 Password Codes.....	1-5
1.3	Service Required Errors.....	1-5
1.4	Error Log Codes	1-5
1.5	Component Check.....	1-7
1.6	Functional Description	1-8
1.7	The Electronic Ignition System.....	1-8
1.8	Smart Interface Board (SIB).....	1-9
1.8.1	Full Vat flow through the SIB Board.....	1-10
1.8.2	Split Vat flow through the SIB Board	1-11
1.8.3	Frequently Used Test Points for SIB.....	1-12
1.8.4	SIB (Smart Interface Board) Troubleshooting.....	1-12
1.8.5	SIB (Smart Interface Board) Pin Positions and Harnesses.....	1-13
1.9	Thermostats	1-14
1.10	Accessing Fryers for Servicing.....	1-14
1.11	Cleaning the Gas Valve Vent Tube.....	1-14
1.12	Checking the Burner Manifold Gas Pressure.....	1-14
1.13	Measuring Flame Current.....	1-16
1.14	Replacing Fryer Components.....	1-16
1.14.1	Replacing the Controller or the Controller Wiring Harnesses.....	1-16
1.14.2	Replacing the SIB	1-17
1.14.3	Replacing the OIB Relay, OIB Relay Board, Transformer or Blower Relay	1-17
1.14.4	Replacing the Temp Probe, ATO Probe, VIB Probe, OIB Sensor or High-Limit	1-17
1.14.5	Replacing an Ignition Module	1-18
1.14.6	Replacing an Ignitor Assembly.....	1-18
1.14.7	Replacing or Cleaning a Combustion Air Blower.....	1-19
1.14.8	Adjusting the Air/Gas Mixture.....	1-20
1.14.9	Replacing a Gas Valve	1-21
1.14.10	Replacing a Burner Assembly	1-22
1.14.11	Replacing the Filter Motor or Filter Pump.....	1-23
1.14.12	Replacing the Frypot	1-23
1.14.13	Replacing Frypot Insulation and/or Upper Burner Rails	1-24
1.15	Troubleshooting and Problem Isolation	1-27
1.15.1	Heating (Ignition) Failure	1-28
1.15.2	Improper Burner Function	1-29
1.15.3	Improper Temperature Control	1-30
1.15.4	Controller Malfunctions.....	1-30
1.15.5	Filtration Malfunctions.....	1-30
1.15.6	Leakage	1-31
1.16	Troubleshooting Guides	1-31
1.16.1	Troubleshooting the 24 VAC Circuit.....	1-32

1.16.2	Troubleshooting the Gas Valve.....	1-32
1.16.3	Troubleshooting the Temperature Probe.....	1-32
1.16.4	Replacing the Reset Switch.....	1-32
1.17	Probe Resistance Chart.....	1-33
1.18	ATO (Automatic Top-Off) and Filtration Service Procedures	1-34
1.18.1	ATO (Automatic Top-Off Troubleshooting)	1-34
1.18.2	Filtration Troubleshooting.....	1-37
1.18.3	Test points on rear of FIB box.....	1-39
1.18.3.1	12-pin connector on rear FIB box.....	1-39
1.18.3.2	Connections on rear of FIB box	1-39
1.18.4	FIB (Filter Interface Board) Filtration Top-off Pin Positions and Harnesses	1-40
1.18.5	Replacing FIB Board, Power Supply, Filter Relay or Transformer	1-41
1.18.5.1	FIB (Filter Interface Board) LED's and Test Points	1-41
1.18.6	Replacing the ATO Pump or Solenoid.....	1-42
1.19	FIB (Filter Interface Board) Service Procedures	1-42
1.19.1	Manually Draining, Refilling, Filtering or Topping off - Manual Filtration Mode	1-42
1.19.2	Control Power Reset Switch	1-42
1.20	Bulk Oil Service Issues.....	1-43
1.20.1	Bulk FIB Tests.....	1-43
1.20.2	Bulk Oil Wiring Connection behind Fryer	1-44
1.20.3	Frymaster FQ-T Fryer and Bulk Oil System Plumbing Schematic	1-44
1.20.4	Bulk Test Quick Reference.....	1-45
1.20.4.1	Dispose to Waste, Refill Vat from Bulk.....	1-45
1.20.4.2	Dispose to Waste	1-45
1.20.4.3	Fill Vat from Bulk.....	1-46
1.20.4.4	Fill Oil Reservoir from Bulk.....	1-46
1.20.5	Troubleshooting Oil Reservoir Filling	1-46
1.21	VIB (Valve Interface Board) Service Procedures	1-47
1.21.1	VIB (Valve Interface Board) Troubleshooting.....	1-48
1.21.2	VIB (Valve Interface Board) Pin Positions and Harnesses	1-49
1.21.3	Replacing a VIB (Valve Interface Board) Board.....	1-50
1.21.4	Replacing a Rotary Actuator.....	1-50
1.21.5	Oil Level Sensor	1-50
1.21.5.1	Oil Level Sensor Troubleshooting.....	1-51
1.21.5.2	Oil Level Sensor Diagram.....	1-51
1.22	FQ4000 Controller Service Procedures.....	1-52
1.22.1	FQ4000 Controller Troubleshooting.....	1-52
1.22.1.1	FQ4000 Controller Functional Troubleshooting.....	1-54
1.23	Loading and Updating Software Procedures.....	1-55
1.23.1	Updating Menu Files.....	1-56
1.23.1.1	Taco Bell Menu Update Instructions.....	1-56
1.23.1.2	General Market Menu (Non-Taco Bell) Update Instructions.....	1-57
1.23.1.3	Software/Menu Update Troubleshooting	1-57
1.24	Wiring Diagrams	1-59
1.24.1	FQ30-T Series Simplified Wiring.....	1-59
1.24.2	Full Vat Wiring Diagram Non-CE Domestic US with OIB Sensor (Prior to 06/2019) 1-60	
1.24.3	Full Vat Wiring Diagram Non-CE Domestic US with OIB Sensor (After 05/2019)	1-61
1.24.4	Dual Vat Wiring Diagram Non-CE Domestic US with OIB Sensor (Prior to 06/2019)1-62	
1.24.5	Dual Vat Wiring Diagram Non-CE Domestic US with OIB Sensor (After 05/2019) ..	1-63
1.24.6	Full Vat Wiring Diagram Non-CE Domestic US without OIB Sensor (Prior to 06/2019)1-64	

1.24.7	Full Vat Wiring Diagram Non-CE Domestic US without OIB Sensor (After 05/2019)	1-65
1.24.8	Dual Vat Wiring Diagram Non-CE Domestic US without OIB Sensor(Prior to 06/2019)	1-66
1.24.9	Dual Vat Wiring Diagram Non-CE Domestic US without OIB Sensor (After 05/2019)	1-66
1.24.10	430-530 Transformer Wiring Diagram Non-CE	1-68
1.24.11	Full Vat Wiring Diagram CE with OIB Sensor (Prior to 06/2019).....	1-69
1.24.12	Full Vat Wiring Diagram CE with OIB Sensor (After 05/2019))	1-70
1.24.13	Dual Vat Wiring Diagram CE with OIB Sensor (Prior to 06/2019).....	1-71
1.24.14	Dual Vat Wiring Diagram CE with OIB Sensor (After 05/2019)	1-72
1.24.15	430-530 Transformer Wiring Diagram CE	1-73
1.24.16	Full Vat Wiring Diagram Australia with OIB Sensor (Prior to 06/2019).....	1-74
1.24.17	Full Vat Wiring Diagram Australia with OIB Sensor (After 05/2019)	1-75
1.24.18	Dual Vat Wiring Diagram Australia with OIB Sensor (Prior to 06/2019).....	1-76
1.24.19	Dual Vat Wiring Diagram Australia with OIB Sensor (After 05/2019)	1-77
1.24.20	Solid Shortening Melting Unit Wiring Diagram.....	1-78
1.24.21	Solid Shortening System Wiring Diagram	1-79
1.24.22	Basketlift Wiring Diagram.....	1-80

FQ30-T SERIES FILTERQUICK GAS FRYERS

CHAPTER 1: SERVICE PROCEDURES

1.1 FQ4000 Menu Summary Trees

1.1.1 FQ4000 Menu Tree General Market/Burger King (Non-Taco Bell)



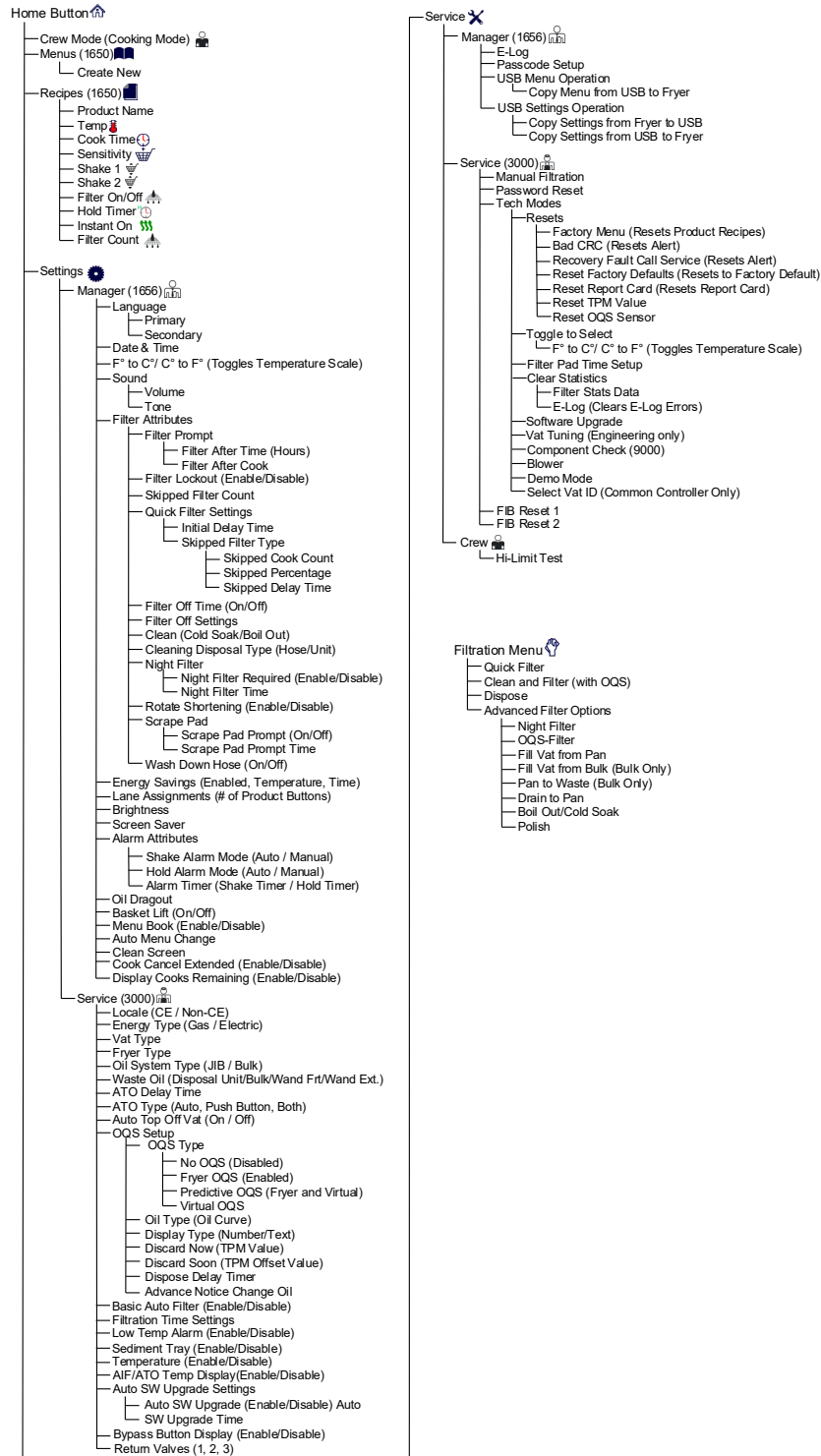











Reflected below are the major programming sections in the FQ4000 and the order in which the headings will be found in the controller.



1.1.2 FQ4000 Information Statistics Menu Tree General Market/Burger King (Non-Taco Bell)

Reflected below are the information statistics in the FQ4000 and the order in which the headings will be found in the controller.

Information Statistics 

- Daily Stats 
 - 1. Filters/Skipped Filters/Cooks Today's
- Report Card 
 - 1. Today's Report
 - 2. Yesterday's Report
 - 3. Weekly Report
- Oil 
 - 1. Last Dispose Date
 - 2. Cooks Since Last Dispose
 - 3. Filters Since Last Dispose
 - 4. Skipped Filters Since Last Dispose
 - 5. Current Oil Life
 - 6. Average Cooks Over Oil Life
 - 7. Daily Dispose Bypass Count
 - 8. Oil Dragout per Dispose
 - 9. Oil Dragout per Day
 - 10. Oil Dragout per Hour
- TPM Statistics 
- Filter 
 - 1. Current Day and Date
 - 2. Cooks Remaining Until Next Filter
 - 3. Daily Number of Cooks
 - 4. Daily Number of Filters
 - 5. Daily Number of Skipped Filters
 - 6. Average Cooks Per Filter
 - 7. Weekly Number of Filters
 - 8. Weekly Number of Skipped Filters
 - 9. Filtration
- Filter Reset  (Resets Filter Stats Data 4321)
- Fresh Oil 
 - 1. Number of Cooks Since Last Dispose
 - 2. Dispose Count Since Last Reset
 - 3. Fresh Oil Counter Reset Date
 - 4. Fresh Oil Counter
- Fresh Oil Reset  (Resets Fresh Oil Data 4321)
- Software Version 
 - 1. UIB/UIC Software Version
 - 2. SIB Software Version (1, 2 – Splits)
 - 3. VIB Software Version
 - 4. FIB Software Version
 - 5. OQS Software Version
 - 6. Actual Vat Temp (L, R – Splits)
 - 7. AIF RTD Temp (L, R – Splits)
 - 8. ATO RTD Temp (L, R – Splits)
 - 9. Board ID
 - 10. Gateway Software Version
 - 11. Gateway IP Address
 - 12. Gateway Link Quality
 - 13. Gateway Signal Strength and Noise
 - 14. IOB Software Version
- Recovery 
 - 1. Last Recovery Time
- Usage 
 - 1. Usage Start Date
 - 2. Total Number of Cook Cycles
 - 3. Total Number of Quit Cook Cycles
 - 4. Total Vat On Time (Hours)
- Usage Reset  (Resets Usage Data 4321)
- Life 
 - 1. Commission Date
 - 2. Unit Serial Number
 - 3. Controller Serial Number
 - 4. Total On Time (Hours)
 - 5. Total Heat Cycle Count
 - 6. Total Energy Saving Time
 - 7. Total Cook Time
 - 8. BSP Version (Common Controller Only)
- Last Load 
 - 1. Last Cooked Product
 - 2. Last Load Start Time
 - 3. Last Load Cook Time
 - 4. Last Load Program Time
 - 5. Last Load Max Vat Temp
 - 6. Last Load Min Vat Temp
 - 7. Last Load Avg Vat Temp
 - 8. % of Cook Time, Heat Is On
 - 9. Vat Temp Before Cook Starts
 - 10. Vat Temp at Cook End

1.1.3 FQ4000 Menu Tree Taco Bell













Reflected below are the major programming sections in the FQ4000 and the order in which the headings will be found in the controller.



1.1.4 FQ4000 Information Statistics Menu Tree Taco Bell

Reflected below are the information statistics in the FQ4000 and the order in which the headings will be found in the controller.

Information Statistics

- Report Card 
 - 1. Today's Report
 - 2. Yesterday's Report
 - 3. Weekly Report
- Oil 
 - 1. Last Dispose Date
 - 2. Cooks Since Last Dispose
 - 3. Filters Since Last Dispose
 - 4. Skipped Filters Since Last Dispose
 - 5. Current Oil Life
 - 6. Average Cooks Over Oil Life
 - 7. Daily Dispose Bypass Count
 - 8. Oil Dragout per Dispose
 - 9. Oil Dragout per Day
 - 10. Oil Dragout per Hour
- Life 
 - 1. Commission Date
 - 2. Unit Serial Number
 - 3. Controller Serial Number
 - 4. Total On Time (Hours)
 - 5. Total Heat Cycle Count
 - 6. Total Energy Saving Time
 - 7. Total Cook Time
 - 8. BSP Version (Common Controller Only)
- Usage 
 - 1. Usage Start Date
 - 2. Total Number of Cook Cycles
 - 3. Total Number of Quit Cook Cycles
 - 4. Total Vat On Time (Hours)
- Recovery 
 - 1. Last Recovery Time
- Filter 
 - 1. Current Day and Date
 - 2. Cooks Remaining Until Next Filter
 - 3. Daily Number of Cooks
 - 4. Daily Number of Filters
 - 5. Daily Number of Skipped Filters
 - 6. Average Cooks Per Filter
 - 7. Weekly Number of Filters
 - 8. Weekly Number of Skipped Filters
 - 9. Filtration
- Software Version 
 - 1. UIB/UIC Software Version
 - 2. SIB Software Version (1, 2 – Splits)
 - 3. VIB Software Version
 - 4. FIB Software Version
 - 5. OQS Software Version
 - 6. Actual Vat Temp (L, R – Splits)
 - 7. AIF RTD Temp (L, R – Splits)
 - 8. ATO RTD Temp (L, R – Splits)
 - 9. Board ID
 - 10. Gateway Software Version
 - 11. Gateway IP Address
 - 12. Gateway Link Quality
 - 13. Gateway Signal Strength and Noise
- Reset  (Resets Usage Data 1656)
- Fresh Oil 
 - 1. Number of Cooks Since Last Dispose
 - 2. Dispose Count Since Last Reset
 - 3. Fresh Oil Counter Reset Date
 - 4. Fresh Oil Counter
- Fresh Oil Reset  (Resets Fresh Oil Data 1656)
- Last Load 
 - 1. Last Cooked Product
 - 2. Last Load Start Time
 - 3. Last Load Cook Time
 - 4. Last Load Program Time
 - 5. Last Load Max Vat Temp
 - 6. Last Load Min Vat Temp
 - 7. Last Load Avg Vat Temp
 - 8. % of Cook Time, Heat Is On
 - 9. Vat Temp Before Cook Starts
 - 10. Vat Temp at Cooks End
- TPM Statistics 

1.2 FQ4000 Password Codes

Press the HOME button to enter MENUS, RECIPES, SETTINGS or SERVICE menus.

- **1650 – MENUS, RECIPES,**
- **1656 – SETTINGS (MANAGER), SERVICE (MANAGER)**
- **3000 – SETTINGS (SERVICE), SERVICE (SERVICE) Enter Tech Mode**
- **9000 – Component Check [SETTINGS (SERVICE), SERVICE (SERVICE) Enter Tech Mode]**

The following code is entered when prompted to do so.

- **1111 – Reset SERVICE REQUIRED Message** – Enter when the issue is fixed and prompted to enter code.

1.3 Service Required Errors

A SERVICE REQUIRED error with a description of the error displays on the controller. After YES is pressed the alarm is silenced. The controller displays an error message from the list below three times with the location of the error. Then the controller displays SYSTEM ERROR FIXED? YES/NO. If yes is chosen, enter code 1111. If NO is chosen, the system returns to cook mode if possible, for 15 minutes, then redisplay error until issue is fixed.

1.4 Error Log Codes

To access the error log, press the home button. Press the service button. Press the manager button. Enter 1656 and press the check button. Press the E-log button. The ten most recent errors are listed from top to bottom, with the top error being the most recent error. A "G" indicates a global error such as a filtration error. Side specific errors in split vats are indicated by L for left or R for right. Pressing the left down arrow allows scrolling through the errors. If no errors are present the screen will be blank.

Code	ERROR MESSAGE	EXPLANATION
E13	TEMPERATURE PROBE FAILURE	TEMP Probe reading out of range
E16	HIGH LIMIT 1 EXCEEDED	High limit temperature is past more than 410°F (210°C), or in CE countries, 395°F (202°C)
E17	HIGH LIMIT 2 EXCEEDED	High limit switch has opened.
E18	HIGH LIMIT PROBLEM DISCONNECT POWER	Vat temperature exceeds 460°F (238°C) and the high limit has failed to open. Immediately disconnect power to the fryer and call service.
E19	HEATING FAILURE – XXX F or XXX C	Heating Control latch circuit failed. Heat Contactor failed to latch.
E25	HEATING FAILURE - BLOWER	The air pressure switch(s) failed to close.
E27	HEATING FAILURE - PRESSURE SWITCH - CALL SERVICE	The air pressure switch has failed closed.
E28	HEATING FAILURE – XXX F or XXX C	The fryer has failed to ignite and has locked out the ignition module.
E29	TOP OFF PROBE FAILURE - CALL SERVICE	ATO RTD reading out of range
E32	DRAIN VALVE NOT OPEN - FILTRATION AND TOP OFF DISABLED - CALL SERVICE	Drain valve was trying to open and confirmation is missing
E33	DRAIN VALVE NOT CLOSED - FILTRATION AND TOP OFF DISABLED - CALL SERVICE	Drain valve was trying to close and confirmation is missing
E34	RETURN VALVE NOT OPEN - FILTRATION AND TOP OFF DISABLED - CALL SERVICE	Return valve was trying to open and confirmation is missing
E35	RETURN VALVE NOT CLOSED - FILTRATION AND TOP OFF DISABLED - CALL SERVICE	Return valve was trying to close and confirmation is missing
E36	VALVE INTERFACE BOARD FAILURE - FILTRATION AND TOP OFF DISABLED - CALL SERVICE	Valve Interface Board connections lost or board failure.
E37	AUTOMATIC INTERMITTENT FILTRATION PROBE FAILURE - FILTRATION DISABLED - CALL SERVICE	AIF (VIB Probe) RTD reading out of range.
E39	CHANGE FILTER PAD	25-hour timer has expired or dirty filter logic has activated.
E41	OIL IN PAN ERROR	The system detects that oil may be present in the filter pan.
E42	CLOGGED DRAIN (Gas)	Vat did not empty during filtration
E43	OIL SENSOR FAILURE - CALL SERVICE	Oil level sensor may have failed.
E44	RECOVERY FAULT	Recovery time exceeded maximum time limit.
E45	RECOVERY FAULT – CALL SERVICE	Recovery time exceeded maximum time limit for two or more cycles. Reset the error code by going to: HOME -> SERVICE -> SERVICE ->3000-> TECH MODE -> RESETS -> RECOVERY FAULT CALL SERVICE -> YES.

Code	ERROR MESSAGE	EXPLANATION
E46	SYSTEM INTERFACE BOARD 1 MISSING - CALL SERVICE	SIB board 1 connection lost or board failure.
E51	DUPLICATE BOARD ID - CALL SERVICE	Two or more controllers have the same location ID.
E52	USER INTERFACE CONTROLLER ERROR - CALL SERVICE	The controller has an unknown error.
E53	CAN BUS ERROR - CALL SERVICE	Communications are lost between boards.
E55	SYSTEM INTERFACE BOARD 2 MISSING - CALL SERVICE	SIB board 2 connection lost or board failure.
E62	SLOW HEATING FAILURE XXXF OR XXXC - CHECK ENERGY SOURCE - CALL SERVICE	The vat is not heating properly.
E63	RATE OF RISE	Rate of rise error occurred during a recovery test.
E64	FILTRATION INTERFACE BOARD FAILURE - FILTRATION AND TOP OFF DISABLED - CALL SERVICE	Filtration Interface Board connections lost or board failure.
E65	CLEAN OIB SENSOR – XXX F OR XXX C - CALL SERVICE or OIL LEVEL NOT DETECTED	Gas -The oil is back sensor does not detect oil. Ensure the vat is full of oil and it's above the sensor and press X (NO). Press v (YES) to clean the oil sensor (see section 4.2.7 in FQG30-T IO manual). If sensor is clean and the error continues, troubleshoot the time delay relay board. If the time delay relay board is functional, troubleshoot the OIB relay. If the issue continues, ensure the OIB sensor is working (see section 1.21.5).
E66	DRAIN VALVE OPEN – XXXF OR XXXC	Drain valve is opened during cooking.
E67	SYSTEM INTERFACE BOARD NOT CONFIGURED - CALL SERVICE	Controller is turned on when the SIB board is not configured.
E68	OIB FUSE TRIPPED – CALL SERVICE	The VIB board OIB fuse has tripped and didn't reset.
E69	RECIPES NOT AVAILABLE	The controller has not been programmed with product recipes. Replace controller with factory programmed controller.
E70	OQS TEMP HIGH	Oil temperature is too high for a valid OQS reading. Filter at a temperature between 300°F (149°C) and 375°F (191°C).
E71	OQS TEMP LOW	Oil temperature is too low for a valid OQS reading. Filter at a temperature between 300°F (149°C) and 375°F (191°C).
E72	TPM RANGE LOW	The TPM is too low for a valid OQS reading. This may also be seen with fresh new oil. The incorrect oil type may be selected in the setup menu. The sensor may not be calibrated for the oil type. See oil type chart in instruction document 8197316. If issue continues contact an FAS.
E73	TPM RANGE HIGH	The TPM reading is too high for a valid OQS reading. Dispose the oil.
E74	OQS ERROR	The OQS has an internal error. If issue continues contact an FAS.
E75	OQS AIR ERROR	The OQS is detecting air in the oil. Check the O-rings and check/tighten prescreen filter to ensure no air is entering the OQS sensor. If issue continues contact an FAS.
E76	OQS ERROR	The OQS sensor has a communication error. Check connections to the OQS sensor. Power cycle the entire fryer battery. If issue continues contact an FAS.
E81	SAFE MODE FAILURE ERROR	The system has detected the fryer is not heating properly due to low oil conditions. Turn the fryer off. Ensure the fryer has oil to the bottom fill line or higher. If not, add oil to the bottom fill line. Turn fryer back on. If prompted, enter code 4357.
E82	LOW OIL DETECTED	This is only visible in the cloud. It's not visible on the UI. The vat doesn't have enough oil to cover the AIF/ATO probes. Fill the vat with oil.
E83	TOP OFF EMPTY	This is only visible in the cloud. It's not visible on the UI. The JIB is out of oil. Replace the JIB and top off the vat.
E85	LEFT RETURN VALVE or LEFT VALVE NOT OPEN VALVE NOT OPE - FILTRATION AND TOP OFF DISABLED - CALL SERVICE	Left return valve was trying to open, and confirmation is missing
E86	LEFT RETURN VALVE or LEFT VALVE NOT CLOSED - FILTRATION AND TOP OFF DISABLED - CALL SERVICE	Left Return valve was trying to close, and confirmation is missing

Code	ERROR MESSAGE	EXPLANATION
E87	RIGHT RETURN VALVE or CENTRAL VALVE NOT OPEN - FILTRATION AND TOP OFF DISABLED - CALL SERVICE	Right return valve or Central Valve was trying to open, and confirmation is missing
E88	RIGHT RETURN VALVE or CENTRAL VALVE NOT CLOSED - FILTRATION AND TOP OFF DISABLED - CALL SERVICE	Right return valve or Central Valve was trying to close, and confirmation is missing

1.5 Component Check

The FQ4000 controller has a function to check the major components and their status.

With the controller soft powered OFF, press the HOME button. Select Service, Service, Enter 9000, Select Tech Modes, scroll down and select Component Check.

The component name is above each button. The status of the component is below the function. Pressing the button will change the status of the function to what is stated on the button. If the button is shaded that function is not available unless that function is enabled (such as bulk). The JIB reset button and Waste Tank full only displays the status of the switch.

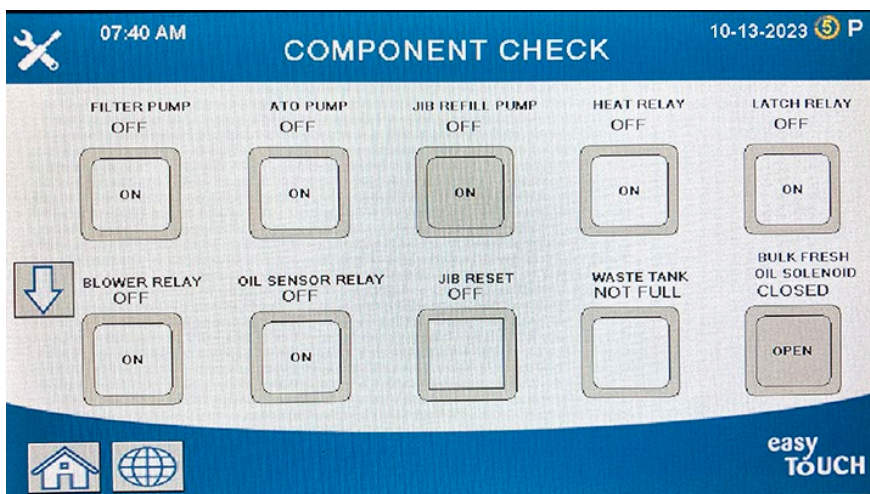

Pressing the home button to exit the function will display driving valves to ensure all valves return to home state. Once completed the controller will display FILL VAT FROM DRAIN PAN? YES NO. Press YES to ensure that any oil in the filter pan is returned to the vat.

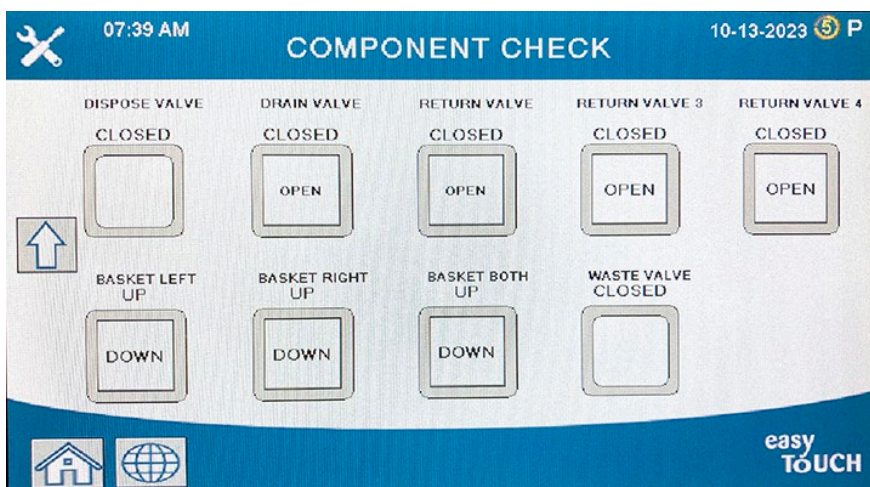

1.6 Functional Description

FQG30-T Series gas fryers contain a welded stainless steel frypot that is directly heated by a high efficiency infrared burner system, requiring approximately 43% less energy than conventional burners to cook the same volume.

Self-contained combustion chambers (referred to as “burners”) are fitted into rails attached to the sides of the frypot, one on each side. Each combustion chamber is fitted with special ceramic tiles that are heated by the burning of a forced air/gas mixture. The tiles transfer heat to the frypot by means of infrared radiation, providing much more constant and uniform heat dispersion over the surface of the frypot than do conventional burners. Because less heat is lost to the atmosphere in the process, compared to “open-burner” designs, less fuel is required to achieve and maintain a given frypot temperature.

In full-vat units, gas flow to both of the burners is regulated by one electromechanical gas valve. In dual-vat units, each burner has its own valve. All fryers in this series are equipped with 24 VAC gas valve systems, and all are configured with electronic ignition.

1.7 The Electronic Ignition System

An ignition module mounted below the component box (located behind the control panel) is connected to an ignitor assembly at the burner. The ignition module performs four important functions: it provides fuse protection for the 24-volt circuit, provides an ignition spark, supplies voltage to the gas valve, and proofs the burner flame. The module contains a four second time delay circuit and a coil that activates the gas valve. All full and dual vat fryers use two single-spark modules.

The ignitor assembly consists of a spark rod, an enrichment tube, and a flame sensor.

At start-up, the power switch on the touchscreen controller is placed in the ON position, supplying approximately 24 VAC to the heat-control circuitry in the Smart Interface Board and to one side of the heat relay coils on the Smart Interface Board. If the resistance in the temperature probe indicates the temperature in the frypot is below 180°F (82°C), the melt cycle function is activated where a timer activates for six seconds and deactivates for 24 seconds. If the temperature is 180°F (82°C) or above, the melt cycle is bypassed. In either case, ground is supplied to the other leg of the heat relay coils, which closes electronic switches in the 24 VAC circuit to provide current to the ignition module. Circuitry in the ignition module sends 24 VAC to the gas valve via a normally closed high-limit switch, and an oil level sensor which is controlled by electronics inside an egg-shaped housing and a 7 second time delay relay board. Simultaneously, the module causes the ignitor to spark for four seconds to light the burner. A flame sensor verifies the burner ignition by measuring the flow of micro amps through the flame. If the burner does not light (or is extinguished), current to the ignition module is cut, the gas valve closes, and the ignition module “locks out” until the power switch is turned off and then back on. A probe monitors the temperature in the frypot. When the programmed setpoint temperature is reached, resistance in the probe causes the heat cycle circuitry in the SIB board to cut off current flow through the heat relay. This in turn cuts off the 24 VAC to the ignition module, causing the gas valve to close.

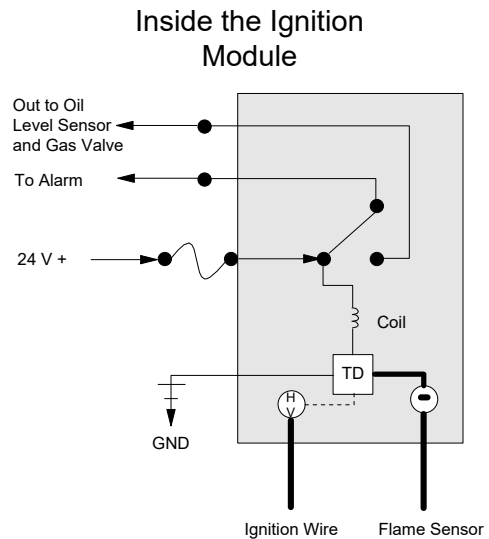

1.8 Smart Interface Board (SIB)

All fryers in this series have a smart interface board (SIB) located in the component box behind the controller panel. The SIB board provides a link between the controller and the fryer's individual components without requiring excessive wiring and executes commands from one central point.

K2 is a single-pole-double throw (SPDT) relay that supplies 24VAC to the ignition and gas valve circuits. The relays on this board are soldered to the board. If a relay fails, the board must be replaced. K1 is a single-pole-double throw (SPDT) relay that supplies voltage through the high limit and the optional air pressure switch.

The SIB LEDs (labeled LED1 through LED7) are arrayed around the board to assist in troubleshooting.

SMART INTERFACE BOARD LED DIAGNOSTIC LIGHTS	
LED 1	24VAC Heat Relay
LED 2	12VDC to Controller
LED 3	24VAC Latch Relay
LED 4	5VDC to probes and switches
LED 6	3.3VDC to Micro Processor
LED 7	Communication to/from Micro Processor

12VDC should be lit and bright at all times. If LED is dim then something is pulling voltage down. Short to ground on 12VDC circuit will cause dim LED.

5VDC should be lit and bright at all times. If LED is dim then something is pulling voltage down. Short to ground on 5VDC circuit will cause dim LED.

When UI is soft powered on this Latch Relay LED will come on first confirming high limit is closed. The blower will then come on and prove the air switch. The relay is a true latch circuit and when broken or turned off the heat relay will also turn off.

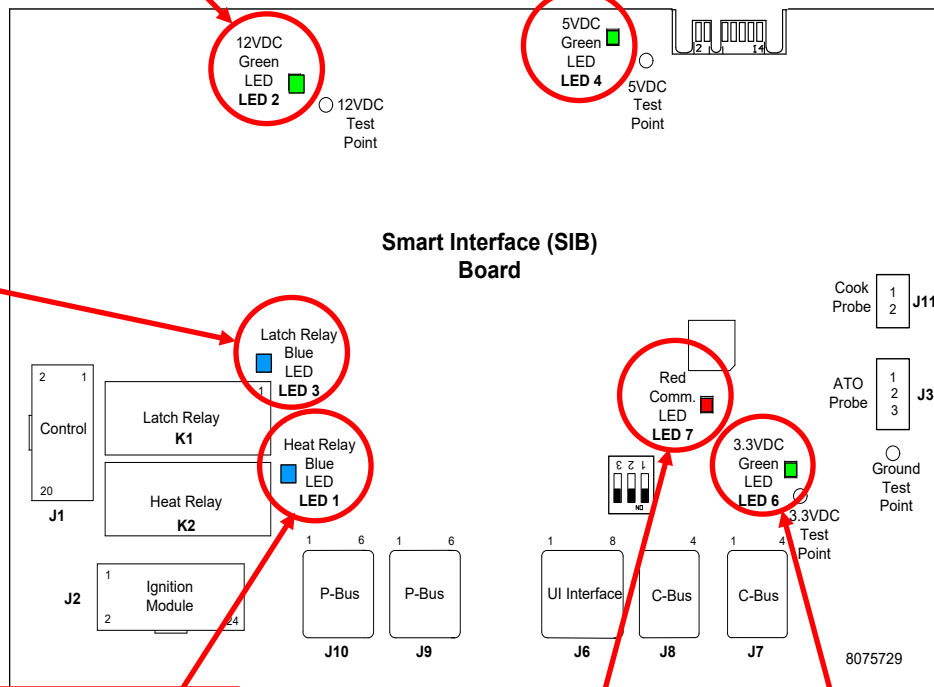

When UI calls for HEAT this LED will come on with the heat relay only after latch relay has been latched in and AIR switch has been proven. This LED will cycle with the call for heat.

Blinking red LED, (Heart Beat). This LED should be blinking and bright at all times when board is powered. The other green LED's being dim or off will cause this LED to be off.

3.3VDC LED should be lit and bright at all times. If dim then something is pulling voltage down. Short to ground on 3.3VDC circuit will cause dim LED.

NOTE: Refer to Section 1.16.1 for troubleshooting flowchart.

The charts on pages 1-10 and 1-11 illustrate current flow through the board, and the table at the top of page 1-12 identifies frequently used test points.

1.8.1 Full Vat flow through the SIB board

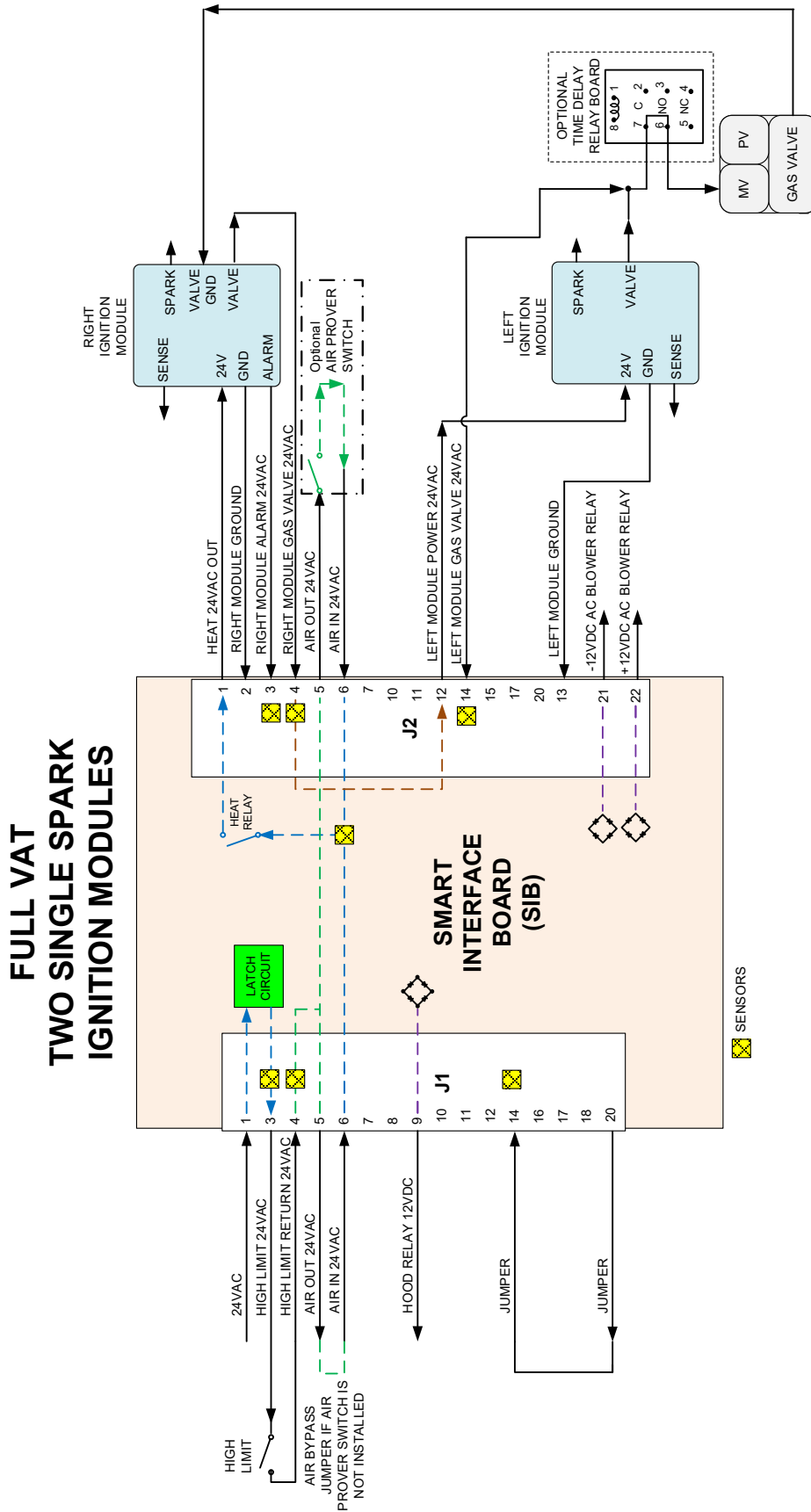

1.8.2 Split Vat flow through the SIB board

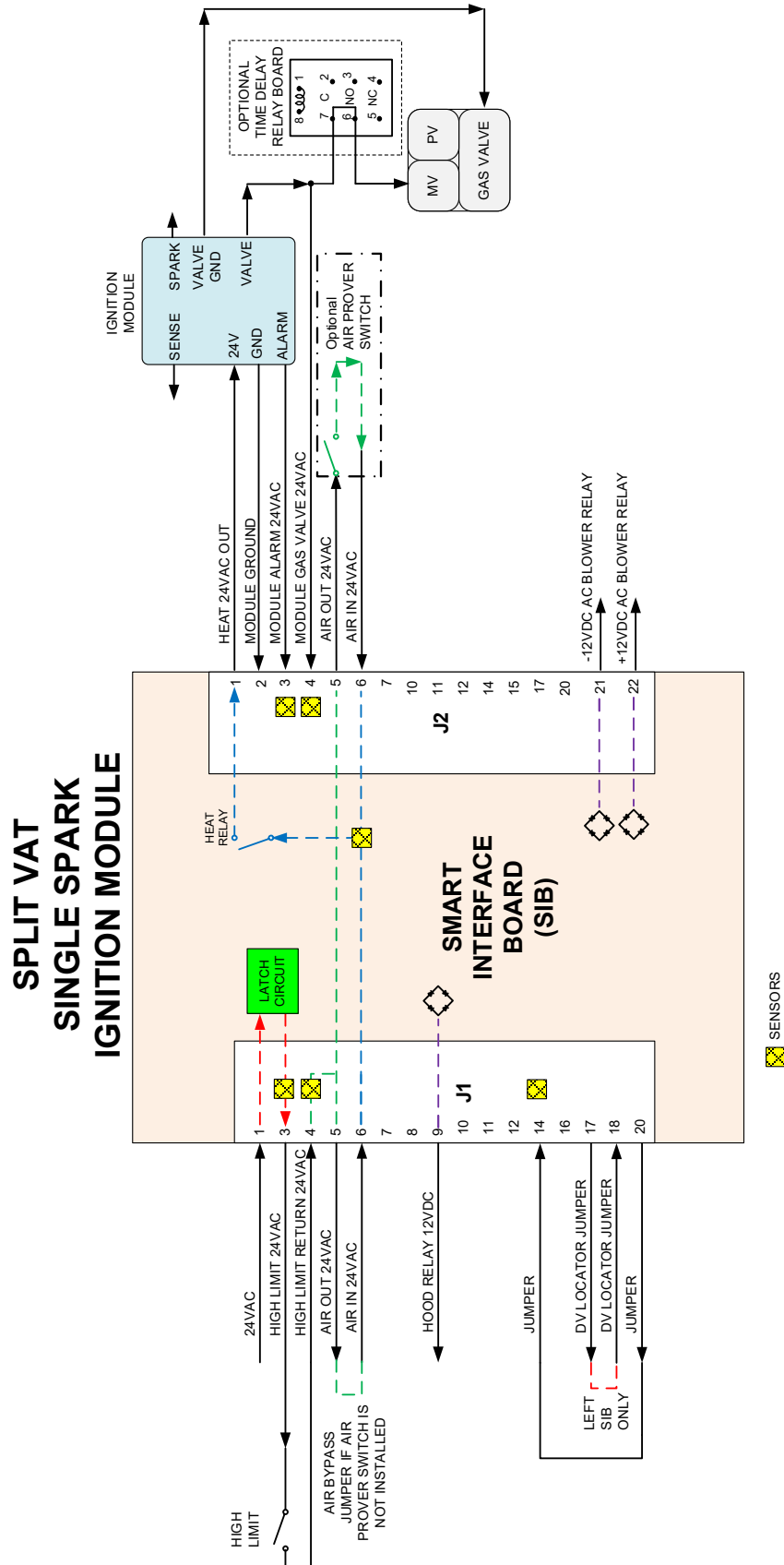

1.8.3 Frequently Used Test Points for SIB (Smart Interface Board)

NOTE: DO NOT CHECK WITH HARNESSES UNPLUGGED AS SHORTING THE PINS MAY OCCUR WHICH WILL DAMAGE THE BOARD.

FREQUENTLY USED TEST POINTS FOR INTERFACE BOARD 1085980			
Test	Meter Setting	Pins	Results
24VAC Power to SIB	50VAC Scale	1 on J1 and GROUND	22-28
12VDC Power to Controller	50VDC Scale	7 and 8 on J6	12-18
24VAC Power to Right Module	50VAC Scale	1 on J2 and GROUND	22-28
24VAC Power to Left Module (if present)	50VAC Scale	12 on J2 and GROUND	22-28
120 VAC Power	250VAC Scale	Blower Connections	110-125
120 VAC Power to Blowers	250VAC Scale	Blower Connections	110-125
24VAC Power to High-Limit	50VAC Scale	3 on J1 and GROUND	22-28
Probe Resistance	R x 1000 OHMS	Disconnect and test across probe leads	**
Probe Isolation	R x 1000 OHMS	2 on Probe Connector and GROUND	***
High-Limit Continuity	R x 1 OHM	3 on J1 and 4 on J1	0
** See Probe Resistance Chart in section 1.17.			
*** 5 mega-Ohms or greater.			

1.8.4 SIB (Smart Interface Board) Troubleshooting

Problem	Probable Causes	Corrective Action
No power to SIB board	A. J1 connection unplugged B. Fuse blown. C. Transformer malfunction	A. Check to ensure J1 on front of SIB board is fully locked into connector. B. Ensure fuse located at the bottom of the control box is not blown and cap is securely tightened. C. Check that proper voltage is present at transformer. See table in section 1.8.3.
SIB BOARD 1 MISSING displayed on the controller.	Loose wire connection.	Ensure the connector is securely attached to plug J6 on the SIB board.
SIB BOARD 2 MISSING displayed on the controller.	Loose wire connection.	Ensure all wiring harnesses are securely connected between J9 and J10 between SIB boards.
SIB NOT CONFIGURED displayed on the controller.	SIB board not configured	Replace the SIB board.
Green LED's on SIB board are blinking or dim.	Damaged harness between J2 on the VIB board to J10 on the SIB board.	Inspect for heat damage and routing of harness close to the frypot. If damaged replace harness (8075555).

1.8.5 SIB (Smart Interface Board) Pin Positions and Harnesses

NOTE: DO NOT CHECK WITH HARNESSES UNPLUGGED (except ATO and Temp Probes) AS SHORTING THE PINS MAY OCCUR WHICH WILL DAMAGE THE BOARD.

Connector	From/To	Harness #	Pin #	Function	Voltage	Wire Color
J1	From Transformer	8076243 Full without OIB 8196364 Full with OIB 8076244 Split without OIB 8076365 Split with OIB	1	24VAC Input	24VAC	Orange
			2	Ground -		Blue
	To High Limit		3	24VAC Out	24VAC	Orange
	From High Limit		4	24VAC Input	24VAC	Blue
	From Basket Lift V-Relay		10	12VDC Input	12VDC	Yellow
	To Right Basket Lift		11	12VDC Out	12VDC	Brown
	To Left Basket Lift		12	12VDC Out	12VDC	Brown
	Left SIB Jumper		17	Ground -		Gray
	Left SIB Jumper		18	5VDC Out	5VDC	Gray
J2	To 24VAC Right Ignition Module		1	24VAC Out	24VAC	Orange
	From 24VAC Right Ignition Module		2	Ground		Green
	From Right Ignition Module		3	Alarm In	24VAC	Yellow
	From Right Module Gas Valve		4	24VAC Input	24VAC	Orange
	To Air Switch		5	24VAC Out	24VAC	Orange
	From Air Switch		6	2VAC Input	24VAC	Blue
	To 24VAC Left Ignition Module		12	24VAC Out	24VAC	Red
	From 24VAC Left Ignition Module		13	Ground		Green
	From Left Module Gas Valve		14	24VAC Input	24VAC	Orange
	To AC Blower Relay		21	AC Blower Relay	-12VDC	Brown
To AC Blower Relay		22	AC Blower Relay	+12VDC	Yellow	
J3	ATO Probe	8263286	1	Ground		Yellow
			2	RTD		Red
			3			
J6	From Controller		1	C-BUS +	5VDC	
			2	C-BUS -	5VDC	
			3	5VDC	5VDC	
			4	RS485 -	5VDC	
			5	RS485 +	5VDC	
			6	Signal Ground		
			7	12VDC	12VDC	
			8	Signal Ground		
J7	C-Bus Harness	8075549 or 8075551	1	5VDC+	+5VDC	
			2	CAN High		
			3	CAN Low		
			4	Ground		
J8	C-Bus Harness or Network Resistor (pins 2 & 3)	8075549 or 8075551 or (8075632 Resistor)	1	5VDC+	+5VDC	
			2	CAN High		
			3	CAN Low		
			4	Ground		
J9	P-Bus Power Communication from SIB to VIB or between SIB's RJ11	8075555 or 8075553	1	Ground		
			2	P-BUS power	+5VDC	
			3	Modbus RS485 B		
			4	Modbus RS485 A		
			5	Signal ground		
			6	P-BUS power	+12VDC	
J10	P-Bus Power Communication from SIB to VIB or between SIB's RJ11	8075555 or 8075553	1	Ground		
			2	P-BUS power	+5VDC	
			3	Modbus RS485 B		
			4	Modbus RS485 A		
			5	Signal ground		
			6	P-BUS power	+12VDC	
J11	Cooking Probe	8263285	1	Ground		Yellow
			2	Probe		Red

1.9 Thermostats

The fryers are equipped with *temperature probes* located on the front centerline of each frypot (dual-vat frypots have two probes, one in each vat). In this type of thermostat, the probe resistance varies directly with the temperature. That is, as the temperature rises, so does resistance, at a rate of approximately 2 ohms for every 1° F. Circuitry in the controller monitors the probe resistance and controls burner firing when the resistance exceeds or falls below programmed temperatures (set points).

The fryers are also equipped with a *high-limit thermostat*. In the event that the fryer fails to properly control the oil temperature, the high-limit thermostat prevents the fryer from overheating to the flash point. The high-limit thermostat acts as a normally closed power switch that opens when exposed to temperatures above 425°F to 450°F (218°C to 232°C). The different types of high limit thermostats have different part numbers for CE and Non-CE models and are not interchangeable.

1.10 Accessing Fryers for Servicing



DANGER

Moving a fryer filled with oil may cause spilling or splattering of the hot liquid. Follow the Drain to Pan instructions in Chapter 2 of the FQ4000 Controller Operation Manual before attempting to relocate a fryer for servicing.

1. Shut off the gas supply to the unit. Unplug the power cords. Disconnect the unit from the gas supply.
2. Remove any attached restraining devices and relocate the fryer for service accessibility.
3. After servicing is complete, reconnect the unit to the gas supply and turn on gas supply, reattach restraining devices, and plug in the electrical cords.

1.11 Cleaning the Gas Valve Vent Tube

1. Set the fryer power switch and the gas valve to the OFF position.
2. Carefully unscrew the vent tube from the gas valve. **NOTE:** The vent tube may be straightened for ease of removal.
3. Pass a piece of ordinary binding wire (.052-inch diameter) through the tube to remove any obstruction.
4. Remove the wire and blow through the tube to ensure it is clear.
5. Reinstall the tube and bend it so that the opening is pointing downward.

1.12 Checking the Burner Manifold Gas Pressure

1. **On non-CE fryers only** ensure that the gas valve knob is in the OFF position.

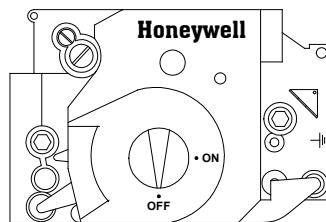

2. Remove the pressure tap plug from the gas valve assembly.

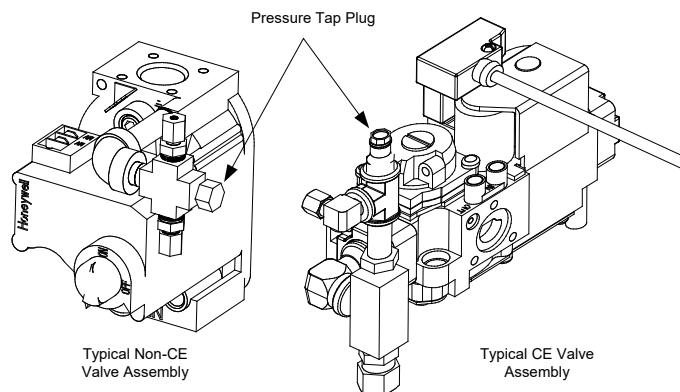

3. Insert the fitting for a gas pressure-measuring device into the pressure tap hole.
4. **On non-CE fryers only**, place the gas valve in the ON position.
5. Place the fryer power switch in the ON position. When the burner has lit and burned steadily for at least one minute, compare the gas pressure reading to the pressure for the corresponding gas in the appropriate table on the following page. The tables on the following page list the burner manifold gas pressures for each of the gas types that can be used with this equipment.
6. To adjust the burner gas pressure, remove the cap from the gas valve regulator and adjust to the correct pressure.

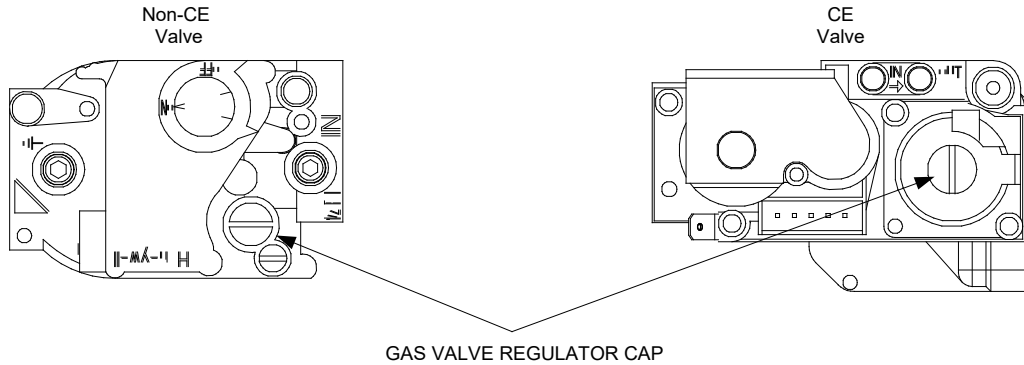

7. Place the fryer power switch (and the gas valve in non-CE fryers) in the OFF position. Remove the fitting from the pressure tap hole and reinstall the pressure tap plug.

Non-CE Standard for Gas Pressure		
Fryer Model	FQG30-T	
Gas Type	Nat (Natural)	LP (Propane)
Incoming Min Pressure WC/kPa/mbar	6/1.49/14.93	11/2.74/27.37
Incoming Max Pressure WC/kPa/mbar	14/3.48/34.84	14/3.48/34.84
Orifice Size (mm)	3.18	2.10
Number of Orifices	2	2
Burner Manifold Pressure WC/kpa	3.00/0.73	8.25/2.5

(1) mbar = 10,2 mm H2O

Korea Standard for Gas Pressure		
Fryer Model	FQG30-T	
Gas Type	LNG (Natural)	LPG (Propane)
Incoming Min Pressure WC/kpa/mbar	4/1.00/10.00	9.2/2.30/23.00
Incoming Max Pressure WC/kpa/mbar	10/2.50/25.00	13.2/3.30/33.00
Orifice Size (mm)	3.18	2.10
Number of Orifices	2	2
Burner Manifold Pressure WC/kPa	3.00/0.73	8.25/2.5

(1) mbar = 10,2 mm H2O

CE Standard for Gas Pressure				
Fryer Model	FQG30-T			
Gas Type	G20 Natural Gas Lacq	G25 Natural Gas Groniqu e	G30 Butane /Propane	G31 Propane
Incoming Min Pressure (mbar)	20	20	28/30	37
Incoming Max Pressure (mbar)	20	25	50	50
Orifice Size (mm)	3.18	3.18	1.95	1.95
Number of Orifices	2	2	2	2
Regulator Pressure Full Vat (mbar)	7	10	17	20.6
Regulator Pressure Dual Vat (mbar)	8	11.2	17	20.6
Burner Manifold Pressure (mbar) Full Vat	7	10	17	20.6
Burner Manifold Pressure (mbar) Dual Vat	8	11.2	17	20.6

(1) mbar = 10,2 mm H2O

1.13 Measuring Flame Current

When the burner flame is properly adjusted, it will produce a current between 2.0 μ A and 2.5 μ A on Fenwal modules. Lockouts can occur at currents 0.5 μ A or below on Fenwal modules. Flame current is measured by placing a **microamp (NOT milliamp)** meter in series with the sensing wire on the ignitor. This is accomplished as follows:

1. Place the controller power switch in the OFF position.
2. Disconnect the sensing wire from one of the burner ignitors (see Figure 1) and connect it to the positive lead of the meter. Connect the negative lead of the meter to the terminal from which the sensing wire was removed.
3. Place the controller power switch in the ON position to light the burners. After the frypot temperature reaches 200°F (93°C), wait at least one minute before checking the reading. **NOTE:** The closer the unit is to normal operating temperature, the more accurate the reading will be.

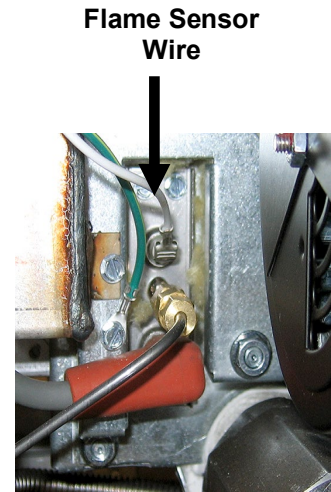

Figure 1

1.14 Replacing Fryer Components

1.14.1 Replacing the Controller

1. **Disconnect the fryer from the electrical power supply. The fuse located at the bottom of the control box can be removed to remove power from individual control boxes.**
2. The controller is held in place by two screws in upper corners.
3. Remove the two screws from the upper corners of the controller.
4. Slide the controller up and it will swing open from the top.
5. Disconnect the RJ45 cable from the SIB board **FIRST**.
6. Disconnect the other cables from the connectors on the back of the controller marking their position for reassembly.
7. Disconnect the lanyard tether.
8. Remove the controller.

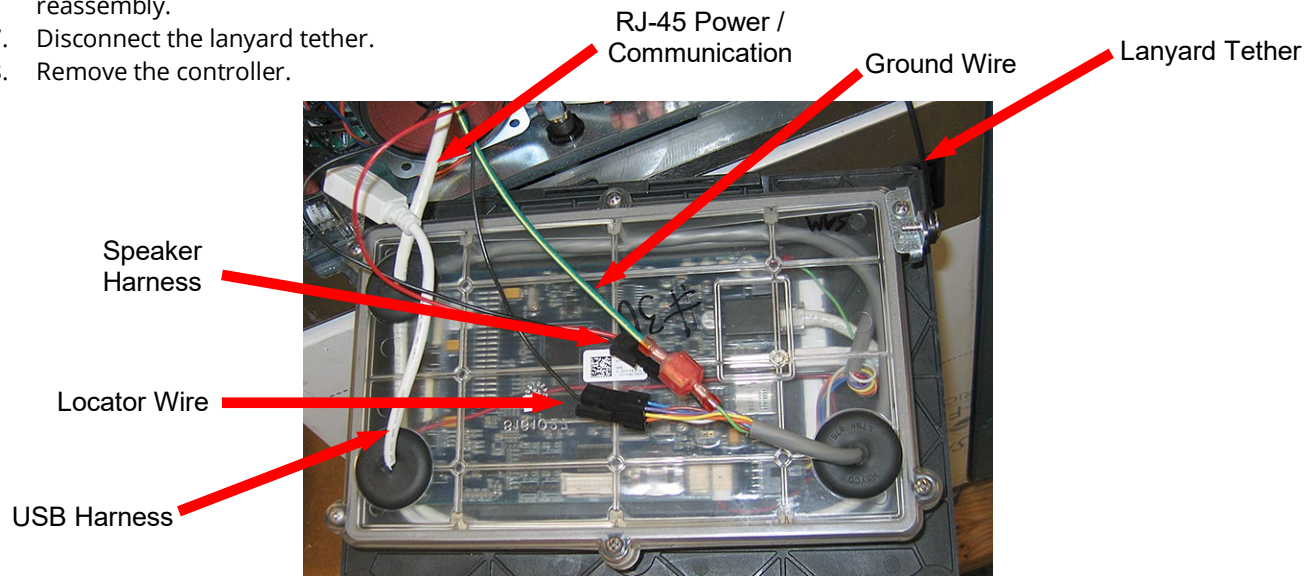

Figure 2

5. For common controllers, it may be necessary to remove the SD card from the failed controller and insert into the rear of the new controller.
6. With the replacement controller face down resting in the control box, **reattach the lanyard tether FIRST**. Failure to reinstall lanyard could result in damage to the SIB board.
7. Reinstall the controller by reversing steps 1 thru 6. **NOTE: Common controllers won't require the locator wire. Tuck back into the control box. Common controllers vat ID is set up in Settings>Tech Service>Vat ID.**
8. Setup the controller following the instructions in section 1.7 of the FQ4000 Controller Operation Manual. If the controller being replaced is in the far-left position the current date and time will need to be setup following the instruction in section 1.8 of the FQ4000 Controller Operation Manual. Setup **MUST** be performed prior to reset.
9. Once setup is complete on all replaced controllers, CYCLE POWER TO ENTIRE FRYER SYSTEM. See section 1.19.2 to reset control power.
10. Check software version and if necessary update the software. If a software update was necessary, follow the instructions to update the software in section 1.23.

1.14.2 Replacing the Smart Interface Board (SIB)

1. Perform steps 1 through 8 from section 1.14.1.
2. Remove the bezel by removing the two (2) screws on the bottom of the bezel.
3. Disconnect the cables attached to the smart interface board, marking or making a note of the connectors to facilitate reconnection.
4. Remove the six nuts attaching the interface board and any strain reliefs.
5. Remove the board from the box. When removing the board, be careful not to lose the spacers that fit over the studs behind the board.
6. Reverse the procedure to install the replacement board, ensure the spacers behind the board are in place and the controller locator wire is attached to a stud.

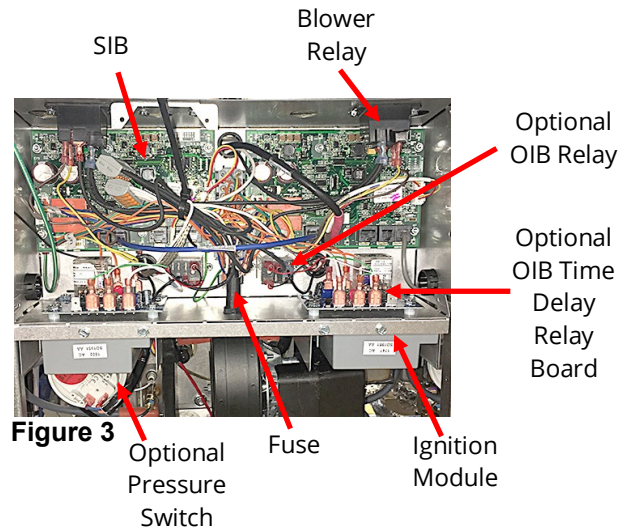

Figure 3

1.14.3 Replacing the optional OIB (Oil Is Back [Oil Sensor] Relay, OIB Time Delay Relay Board, Transformer or Blower Relay

1. Perform steps 1 through 8 from section 1.14.1.
2. Remove the bezel removing the two (2) screws on the bottom of the bezel.
3. Disconnect any cables, marking or making a note of the connectors to facilitate reconnection.
4. Remove the component.
5. Reverse the procedure to install the component.

1.14.4 Replacing the Temperature Probe, ATO Probe, Optional VIB (AIF) Probe, Optional Oil Level (OIB) Sensor or High-Limit Thermostat

1. Disconnect the fryer from the electrical supply or remove fuse on bottom of associated control box.
2. Drain cooking oil below the level of the probe or thermostat to be replaced. If removing the inside vat probes skip to step 4, otherwise continue to next step.
3. Remove the sides if replacing the outside probes and skip to step 6.
4. Remove the blower (see Figure 7 in section 1.14.7).
5. Lower the ignition modules (see steps 3 and 4 in section 1.14.5).
6. Disconnect the component wires as follows:
 - a. If replacing a temp probe or ATO probe, unplug from the SIB board.
 - b. If replacing the high limit, removing the side panel allows access to the probe and top connector on the rear of the control box (see Figure 5). Using a pin pusher, push the wires from the connector.
 - c. If replacing the OIB sensor or VIB (AIF) probe, unplug from the J1 connector on the VIB board.
7. Unscrew the probe or thermostat from the frypot.
8. Apply Loctite® PST56765 pipe thread sealant or equivalent to the replacement part threads and screw the replacement part into the frypot. If replacing an ATO or VIB probe **ensure the probe is flush with the side of the vat** prior to tightening. Torque the component to 180 inch-pounds.
9. Reverse steps 1 through 5 to complete the procedure.

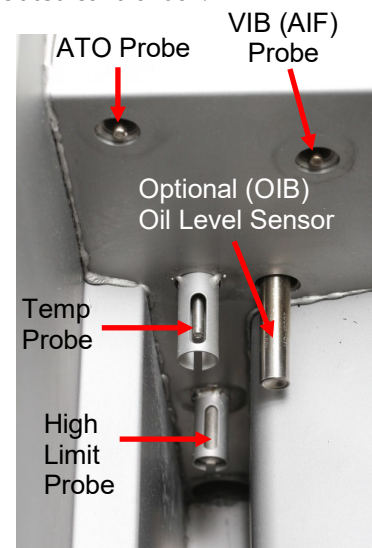

Figure 4

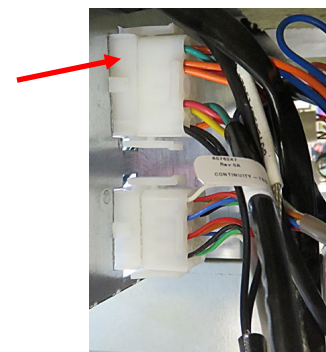

Figure 5

1.14.5 Replacing an Ignition Module

1. Disconnect the fryer from the electrical supply or remove fuse on bottom of associated control box.
2. On a split vat it is necessary to remove the blower to remove the right module.
3. Loosen the two top screws attaching the module assembly to the frame (see Figure 6).
4. Slide the module towards the rear of the component box until the rear tab clears the bottom of the component box frame and can be lowered.
5. Disconnect the module harness, the sensor wire and the spark cable to allow the module assembly to be removed.
6. Remove the cover plate and remove the wires from the ignition module, marking or making a note of the wires and terminals to facilitate reconnection.
7. Remove the nuts attaching the module to the plate.
8. Reverse the procedure to install the replacement module.

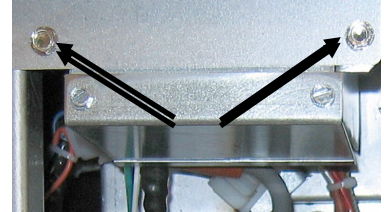

Figure 6

1.14.6 Replacing an Ignitor Assembly



Drain the frypot before proceeding further.

1. Disconnect the fryer from the electrical supply or remove fuse on bottom of associated control box.
2. Disconnect the flame sensor wire by carefully pulling its push-on terminal from the terminal tab on the ignitor (see Figure 7). Disconnect the gas enrichment tube at the ignitor-end compression fitting. Disconnect the ignition cable from the ignitor by grasping its boot and gently pulling toward you.

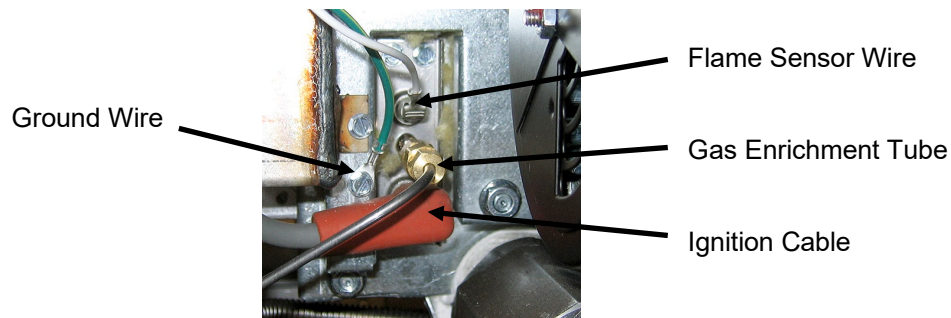

Figure 7

3. Remove the sheet metal screws securing the ignitor to the mounting plate and pull the ignitor from the fryer.
4. Reverse the procedure to install the replacement ignitor. Replace with ignitor specific to fryer gas type.

1.14.7 Replacing or Cleaning a Combustion Air Blower

1. Disconnect the blower wiring harness (see Figure 8), remove the blower assembly mounting nuts, and remove the blower assembly from the fryer. If cleaning the motor, continue with Step 2; otherwise, install the replacement blower, reconnect the wiring harness, and then go to Step 6.

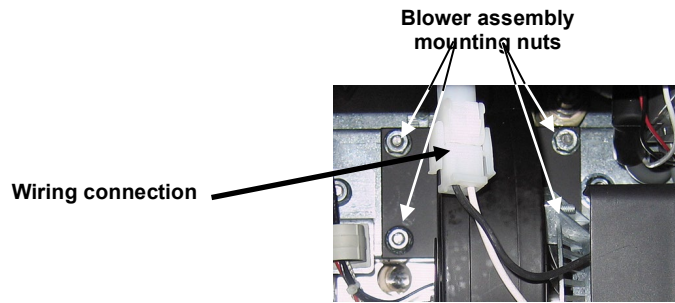

Figure 8

2. Remove the blower motor shield and separate the blower motor from the housing as shown in the illustration below (see Figure 9).

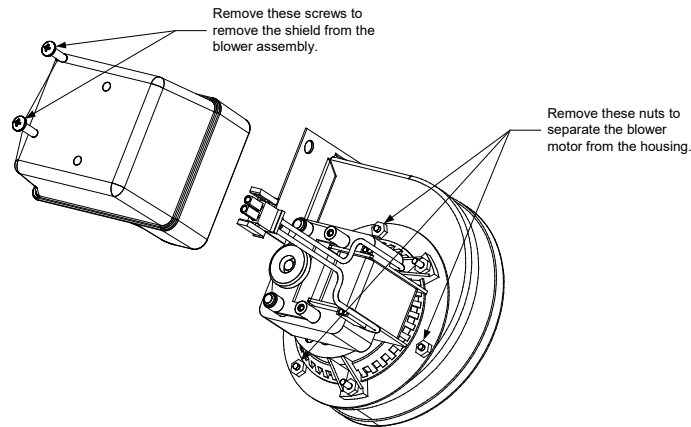

Figure 9

3. Wrap the motor with plastic wrap to prevent water from entering it (see Figure 10). Spray degreaser or detergent on the blower wheel and the blower housing. Allow it to soak for five minutes. Rinse the wheel and housing with hot tap water, then dry with a clean cloth.

NOTICE- Australia Only

The air pressure switch on the combustion blower should read: Full Vat units-122pa (0.5 inches W.C.) and for Split Vat units-180pa (0.72 inches W.C.).

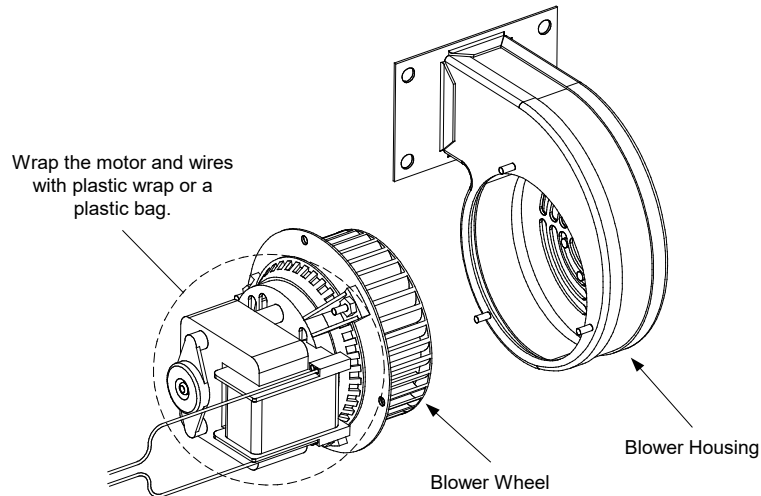

Figure 10

4. Remove the plastic wrap from the blower motor assembly. Reassemble the blower motor assembly and blower housing. Reinstall the blower shield.
5. Reinstall the blower assembly in the fryer and reconnect the wiring disconnected in Step 1.
6. Light the fryer in accordance with the procedure described in Chapter 3, Section 3.1.2 of the FQG30-T Series Gas Fryer Installation and Operation Manual.
7. After the burners have been lit for at least 90 seconds, observe the flames through the burner viewing ports located on each side of the combustion air blower (see Figure 11).

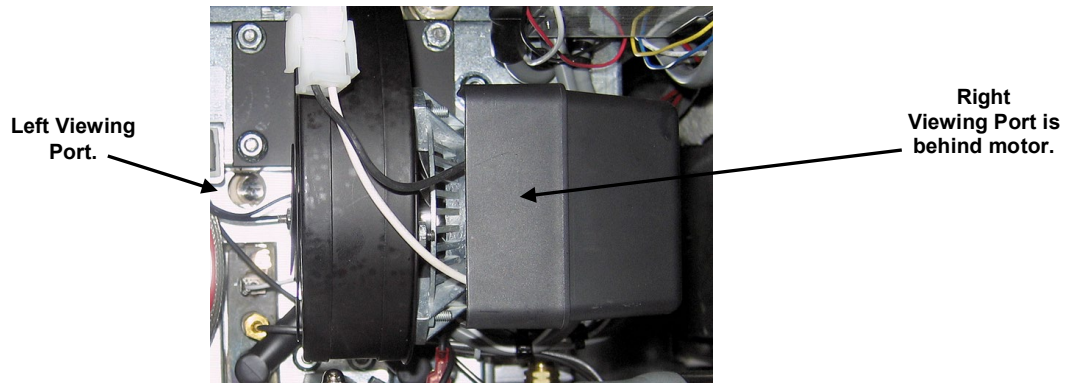

Figure 11

1.14.8 Adjusting the Air/Gas Mixture

On the side of the blower housing opposite the motor is a shutter plate with a locking nut. Loosen the nut enough to allow the shutter to be moved, then adjust the position of the shutter to open or close the air intake opening until a bright orange-red glow is obtained, then close it slightly. Carefully hold the shutter in position and tighten the locking nut (see Figure 12).

The air/gas mixture is properly adjusted when the burner manifold pressure is in accordance with the applicable table on page 1-14 and the burners display a bright orange-red glow. If a blue flame is observed or if there are dark spots on a burner face, the air/gas mixture requires adjustment.

NOTE: Opening the air shutter too much may result in whistling. It should not be more than 1/3 open.

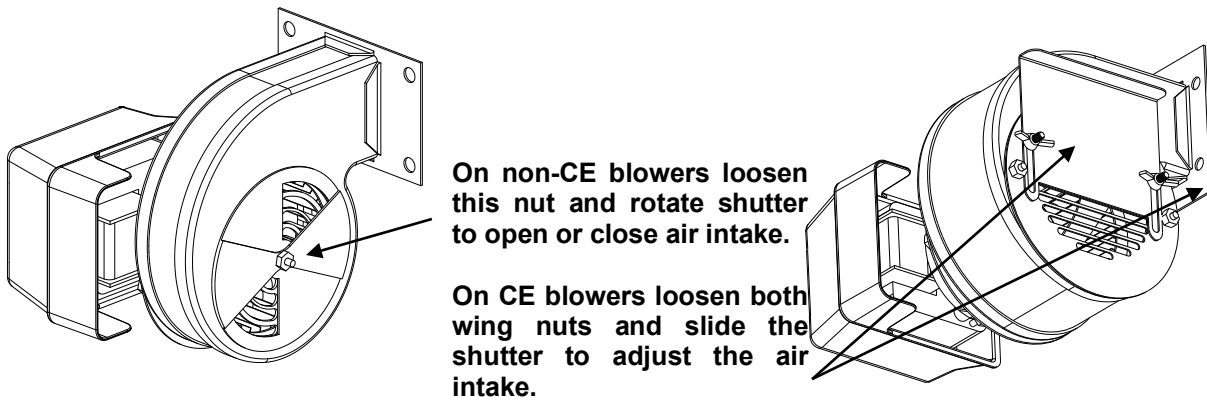

Figure 12

1.14.9 Replacing a Gas Valve

1. Disconnect fryer from electrical and gas supplies.
2. Disconnect the wire harness from the gas valve.
3. Remove the vent tube (on non-CE fryers) and the enrichment tube fitting from the valve. Disconnect the flexible gas line(s).

If replacing the left-most valve or the right most valve on any configuration, follow the instructions below. If replacing valves in other positions, skip to "ALL OTHER VALVES."

- A. Relocate the fryer for service accessibility.
- B. Remove the door adjacent to the valve being replaced.
- C. Remove the side panel closest to the gas valve being replaced by removing the three screws in the front, the single screw under the center and the four screws in the rear.
- D. Remove the filter pan from the unit (valves close to filter pan).
- E. Uncouple the pipe union and remove the gas valve and associated piping from the unit.
- F. Remove the fittings and associated piping from the failed valve and install them on the replacement valve using Loctite® PST56765 or equivalent pipe thread sealant.
- G. Reconnect the gas valve assembly to the fryer using Loctite® PST56765 or equivalent pipe thread sealant, and reattach the flexible gas line(s), enrichment tube(s), and the vent tube (on non-CE units). Reconnect the high-limit thermostat wires and drain safety wires to the valve.
- H. Reconnect the fryer to the gas supply and open the cut off valve. Apply a thick soapy solution of soapy water around each connection to check for gas leaks and ensure there are no bubbles. Eliminate any that are found. There should be no smell of gas.
- I. Install the filter pan in the unit to make sure that all components are properly aligned.
- J. Reconnect the fryer to the electrical power supply and check for proper operation. When proper operation has been verified, reinstall the door removed in Step B.

ALL OTHER VALVES

4. Carefully unscrew the valve from the manifold. **NOTE:** Some models may have the valve attached to the manifold by means of a pipe union. In such cases, remove the valve by uncoupling the union.
5. Remove all fittings from the old gas valve and install them on the replacement valve, using Loctite® PST56765 or equivalent pipe thread sealant.
6. Reconnect the gas valve assembly to the fryer using Loctite® PST56765 or equivalent pipe thread sealant, and reattach the flexible gas line(s), enrichment tube(s), and the vent tube (on non-CE units). Reconnect the high-limit thermostat wires and drain safety wires to the valve.
7. Reconnect the fryer to the gas supply and open the cut off valve. Apply a thick soapy solution of soapy water around each connection to check for gas leaks and ensure there are no bubbles. Eliminate any that are found. There should be no smell of gas.
8. Reconnect the fryer to the electrical power supply and check for proper operation.

1.14.10 Replacing a Burner Assembly

1. Disconnect the unit from the electrical and gas supplies.
2. Remove the gas line and enrichment tube using a 7/16" and 5/8" wrench from the front of the burner.
3. Remove the elbow and tee off the bottom of the burner to ensure easier removal of the burner.
4. Remove the fryer back.
5. Some vats require the removal of actuators.
6. Remove the screws attaching the flue cap to the brace.
7. Remove the top cross brace in the back.
8. Remove the flue by removing the two screws in the rear and one screw in the front of the flue.
9. Remove all the screws on the flue collector and bend back the tabs and remove the collector.
10. Remove four screws on the collector insulation plate (see Figure 14).
11. Remove the four nuts and cover of the lower insulation retaining cover (see Figure 13).
12. Carefully remove the insulation being careful not to damage it.
13. Grasp the burner firmly and slide the burner out the rear of the fryer. Pull it toward you until it clears the burner channels, taking care not to damage the ceramic tiles in the process.
14. Slide the burner out the rear of the fryer.
15. Clean all debris from the burner channels and combustion area.
16. Inspect the upper and lower burner rails for cracked or burned out welds.
 - a. If the welds in the lower rail are cracked or burned out, the frypot must be replaced. Refer to Section 1.14.12 for procedure.
 - b. If the welds in the upper rail are cracked or burned out, the upper rail must be replaced. Refer to Section 1.14.12 for procedure.
17. Wrap a new insulating strip along the top, rear, and bottom edge of the burner. **NOTE:** Use P/N 826-0931 for full-vat frypots and P/N 826-0932 for dual-vat frypots.
18. Carefully slide the replacement burner into the rails starting at the top and lifting slightly up on the bottom (see Figure 15). Ensure that the insulation is not torn or damaged.
19. In reverse order reassemble insulation and holding plates.
20. Install flue collector.
21. Install the flue.
22. Install the cross brace ensuring the flue cap is secured to the brace.
23. Replace the fryer back.
24. Reattach the elbow, gas line and enrichment tubes to the front of the burner.
25. Fill the frypot with oil. Turn the fryer on, bypass the melt cycle, and operate the unit for at least 10 minutes.
26. Visually examine the burner flame. The color and intensity on both sides should be the same.
27. Use an inspection mirror to check for leaks in areas that cannot be directly observed.
28. If a leak is detected, tighten all the lower insulation retainer nuts, allow the frypot to run for five additional minutes, and repeat steps 25 and 26.
29. If the leak persists, use a rubber hammer and a small block of wood to tap the corners of the lower combustion chamber insulation retainers. Repeat steps 25 through 27. **Repeat this step until no leakage is detected.**

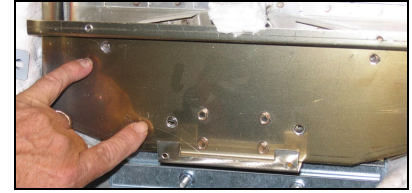

Figure 13

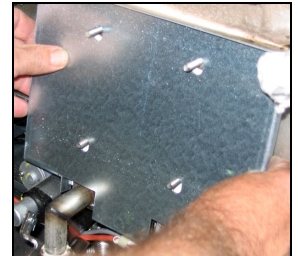

Figure 14



Figure 15

1.14.11 Replacing the Filter Motor or Filter Pump (may differ depending on date of manufacture)

1. Disconnect the unit from the electrical power supply.
2. Remove the filter pan from the unit.
3. Position a container beneath the oil return fitting at the front of the cabinet. Disconnect the flexible oil line from the fitting, allowing any residual oil to drain into the container.
4. At the rear of the fryer, unplug the left connector (as viewed from the rear of the fryer) from the transformer box.
5. Remove the four nuts and bolts attaching the motor mount to the rear motor mount support.
6. At the front of the fryer, remove the cover plate from the front of the motor and disconnect the motor wires.
7. Place a 1-foot (30.5-cm) length of wood (or similar support) beneath the motor mount near the front of the unit and remove the two remaining nuts and bolts attaching the motor mount to the front cabinet cross brace.
8. Carefully remove the support and lower the motor mount to the floor, allowing the rear of the mount to slide forward and off the rear motor mount support.
9. Disconnect the return flexline from the pump. The motor and pump assembly can now be pulled from beneath the fryer and the failed component can be removed and replaced.
10. Position the replacement motor and pump assembly beneath the fryer and reconnect the oil return flexline to the pump. Lift the rear of the motor mount up and onto the rear motor mount support.
11. Lift the front of the motor mount up and support it with a 1-foot (30.5-cm) piece of wood or a similar support. Install but do not tighten the two nuts and bolts that attach the motor mount to the front cabinet cross-brace.
12. Install and tighten the four nuts and bolts that secure the motor mount to the rear motor mount support.
13. At the front of the fryer, tighten the two nuts and bolts at the front of the motor mount. Reconnect the motor power wires and reinstall the wiring cover plate.
14. Reconnect the oil return flexline and reinstall the filter pan.
15. Reconnect the unit to the electrical power supply, fill the frypots with oil and check for proper operation.

1.14.12 Replacing the Frypot

1. Disconnect the fryer from the electrical and gas supplies.
2. Remove the filter pan from the unit and drain one frypot at a time into a Shortening Disposal Unit (SDU) or other appropriate metal container using the drain function under the manual filtration section on the controller (see section 1.19).



DO NOT attempt to drain more than one full frypot or two split frypots into the SDU at one time.

3. Dismount the topcap by removing the screws on the bottom of each front corner and lifting the topcap straight up.
4. Remove the top screws in the upper corners of the controller.
5. Grasp the upper edge of each controller and swing the controller downward. Unplug the controller wiring harnesses and grounding wire from each controller.
6. Remove the controllers by disconnecting the tether and lifting them from the slot in the control panel frame.
7. Unplug the ATO and Temperature probe sensor from the SIB boards marking each wire to facilitate re-assembly.
8. Disconnect the flame sensor wires by carefully pulling the push-on terminals from the terminal strips on the ignitors. Disconnect the gas enrichment tube at the ignitor-end compression fitting. Disconnect the ignition cables from the ignitors by grasping the boots and gently pulling toward you.
9. Remove the two mounting screws on each side of the component box and the center screw in the top rear of the component box.
10. Rotate the top of the box out of the frame. Carefully pull it out enough to disconnect the wiring harness connector from the back of the box. Cut any ties that prevent the box from being pulled out of the control panel frame.
11. Carefully pull the box clear of the frame and rest it on top of the fryer.
12. Disconnect the actuators from the return and drain valves.
13. Remove the section(s) of drain from the drain valve(s) of the frypot to be removed.
14. Disconnect the gas lines from the burner orifices and ignitor assemblies.
15. Remove the frypot hold down bracket.
16. Remove the screws in the back panel and inside the flue cap at each end that secure the flue cap to the fryer and lift it clear of the fryer.

17. Disconnect the oil return line(s) from the frypot to be removed.
18. Disconnect all wiring from the VIB (valve interface board).
19. Carefully lift the frypot from the fryer cabinet.
20. Remove the drain valve(s), temperature probe(s), high-limit thermostat(s), RTD probes, oil level sensor probes, VIB boards, actuators and ignitor assemblies. Inspect each of these components carefully and install them in the replacement frypot if they are in serviceable condition. Use Loctite® PST56765 sealant or equivalent on component threads.
NOTE: Some servicers, based upon their experience, recommend that probes and thermostats be replaced whenever a frypot is replaced; however, this remains the customer's decision.
21. Reverse steps 1-20 to reassemble the fryer.
NOTE: Care should be taken not to over-torque nuts on frypots made of 400-series stainless steel, as this could tear the material. One turn past hand-tight is sufficient torque.
22. Perform steps 14 through 18 of Section 1.14.10 to ensure that there are no leaks in the burner insulation.

 **CAUTION**

Before installing temperature probes, high-limit thermostats, RTD probes, oil level sensor probes, return valves and drain valves on replacement frypot, clean the threads and apply Loctite® PST56765 thread sealant or equivalent.

1.14.13 Replacing Frypot Insulation and/or Upper Burner Rails

NOTE: Replacing the burner rails requires completely tearing down the frypot and installing new frypot insulation. Refer to the frypot exploded view below for component identification.

1. Remove the frypot per Section 1.14.12.
2. Remove the burner assemblies (1).
3. Remove insulation retainers and blanket insulation (2).
4. Remove the upper oil zone insulation bracket and upper oil zone insulation (3).
5. Remove the plenum (4).
6. Remove the front lower combustion chamber insulation retainer and insulation (5), and the front lower combustion chamber inner insulation retainer and insulation (6). **NOTE:** Full-vat units have two-piece insulation retainer and insulation components. Dual-vat units have one-piece components.
7. Remove the upper combustion chamber insulation retainer and insulation (7).
8. Remove the inner upper combustion chamber insulation retainer and insulation (8).
9. Remove the rear lower combustion chamber retainers, back, and insulation (9). **NOTE:** Full-vat units have two-piece backs and four retainers. Dual-vat units have one-piece backs and two retainers.
10. Remove the flue assembly (10).

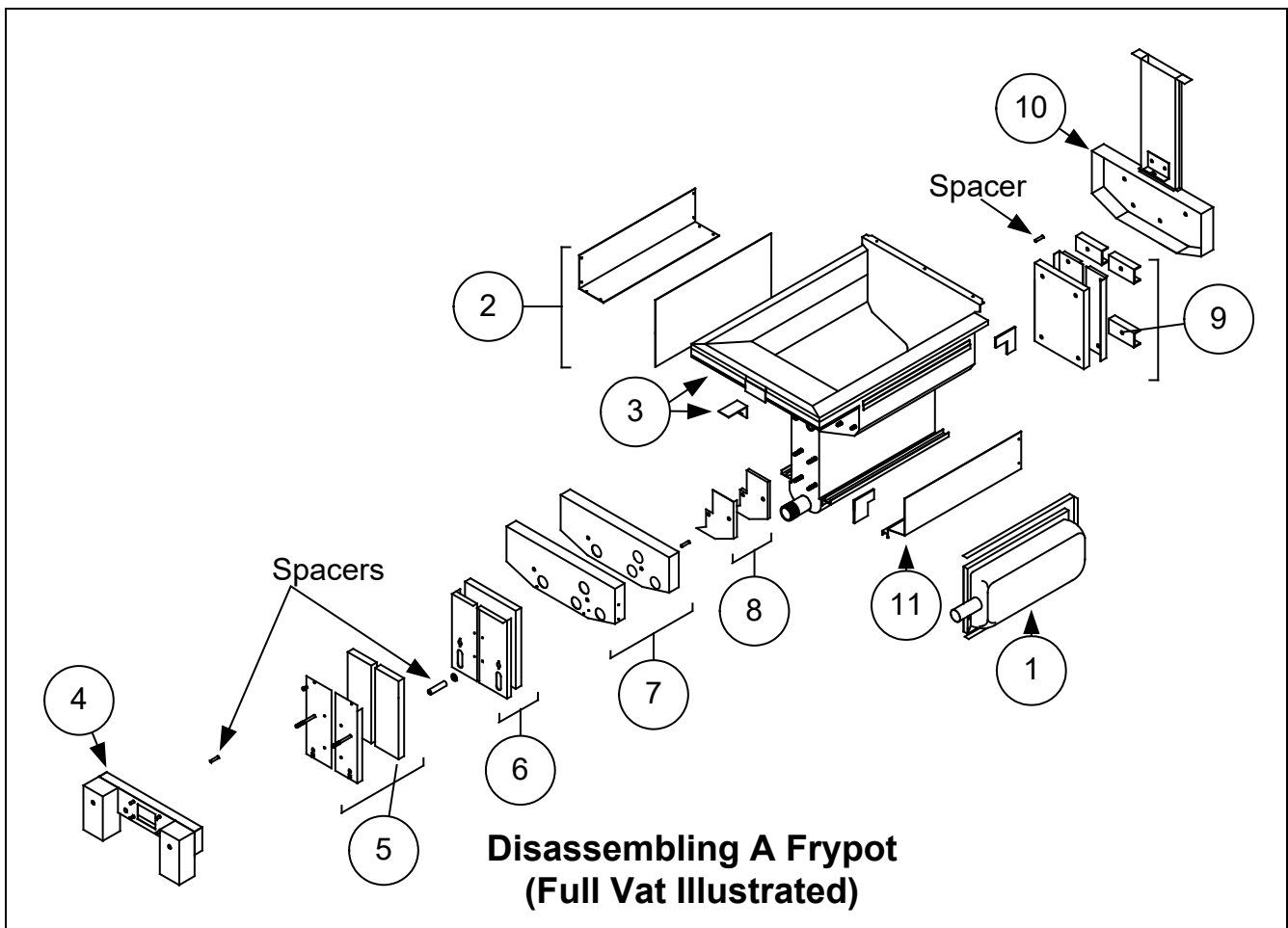

Figure 20 See page 1-27 for reassembly illustration.

11. Remove the upper burner rails (11). **NOTE:** For the following steps, refer to the frypot exploded view on page 1-27 for component identification.
12. Remove any residual insulation, sealant, and/or oil from the exterior of the frypot.
13. Place the “L” shaped pieces of the combustion chamber insulation (1) in the front and rear corners of both upper rail-retaining slots.
14. Using a mallet and short piece of wood, tap the corner tabs of the combustion chamber over the insulation to ensure a solid seal of the burner.
15. Install the upper burner rails (2) with the heat deflectors slanting toward the rear of the frypot. The rails will cover the “L” shaped pieces of combustion chamber insulation previously installed.
16. Place the upper inner combustion chamber insulation and insulation retainers (3) on the top two studs on each side of the front of the frypot and secure with ¼”-20 washer-nuts. *It is normal for the retainers to slice off the overhanging insulation.*
17. Place the lower rear combustion chamber insulation (4) on the lower four studs at the rear of the frypot.
18. Place one 1.625-inch tubular spacer (5) on each of the flue assembly (upper) studs at the rear of the frypot. **NOTE:** There are three different sizes of spacers. Verify the size to ensure the correct spacers are installed.
19. Press the flue assembly (6) over the burner rails. It may be necessary to use a rubber mallet or screwdriver to align the components. Use four ¼”-20 washer nuts to secure the flue assembly. **Do not tighten the retainer nuts at this point. They should be finger-tight only.** **NOTE:** The flue edge will cover one to two inches of the lower insulation.
20. Install the lower rear combustion chamber back(s) and retainer(s) (7) with the flanged edge(s) against the flue. Secure with ¼”-20 washer nuts. **NOTE:** Full-vat units have two-piece backs and four retainers. Dual-vat units come with one-piece backs and only two retainers.
21. Insert the burners (9) into the rails to ensure the rail spacing and alignments are correct. The burner should slide freely into and out of the rails. The upper rail can be bent slightly to increase or decrease tension on the burner and the edges of the slot can be closed or opened slightly to best fit the burner frame.

22. Carefully wrap a strip of burner insulation (8) tightly around the rear and sides of the burner frame (9), with the glass-tape side of the strip on the outside. **Do not use duct tape or adhesive to secure the strip to the burner frame.**
23. Align the burner to the burner rails while maintaining tension on the insulation strip. Insert the burner at a slight angle and begin pushing the burner slowly into the rails until it contacts the rear combustion chamber. The fit should be snug, but not excessively tight.
24. Verify that the burners are flush with the front edge of the burner rails. Remove the excess burner insulation by cutting with a knife or diagonal pliers. **Do not try to tear the insulation!**
25. Insert the upper front insulation (10) into its retainer (11), making sure that the holes in each piece are aligned with one another. Install the assembly with the insulation side toward the frypot and secure with ¼"-20 washer-nuts. **Do not over tighten.**
26. Place a washer on each of the four lower studs on the front of the frypot. Install the lower inner front insulation (12) with the rectangular openings toward the drain valve nipple. Install the lower inner front insulation retainer(s) (13). **NOTE:** Full-vat units have a two-piece insulation retainer. Dual-vat units have a one-piece retainer.
27. If necessary, replace the sight-glasses and insulation (14).
28. Place one washer and one 1.888-inch spacer (15) on each stud. **NOTE:** There are three different sizes of spacers. Verify the size to ensure the correct spacers are installed.
29. Insert the front lower insulation (16) into the front lower insulation retainer(s) (17) and install assembly on frypot. Secure with ¼"-20 washer-nuts. If frypot uses two retainers, connect them together with two ¼" self-tapping screws. **NOTE:** Full-vat units have a two-piece insulation retainer and two pieces of insulation. Dual-vat units have one-piece components.
30. Return to the rear of the frypot and fully tighten all washer-nuts.
31. Remove and replace the plenum gaskets (18).
32. Place a 0.938-inch spacer (19) on the plenum-mounting studs and mount the plenum (20). Ensure the gaskets are clear of the burner tubes by pulling the plenum back slightly. Place a washer on each stud and secure plenum with ¼"-20 lock-nuts.
33. Install the upper oil-zone insulation (21) by pressing it under the upper combustion chamber metalwork. Secure the insulation with the bracket (22) and ¼" self-tapping screws.
34. Install the upper burner rail blanket insulation (23). Position any excess insulation toward the top of the frypot. Avoid overhang past the bottom of the upper burner rail. Overhang in this area will make future burner replacement more difficult.
35. Cover the insulation with the insulation retainer (24), and secure with ¼" self-tapping screws.
36. Reinstall probes, drain valves, VIB boards, actuators, high-limit thermostats, and other pipe fittings using Loctite® PST56765 sealant or equivalent on the threads.
37. Reverse additional steps to reassemble.

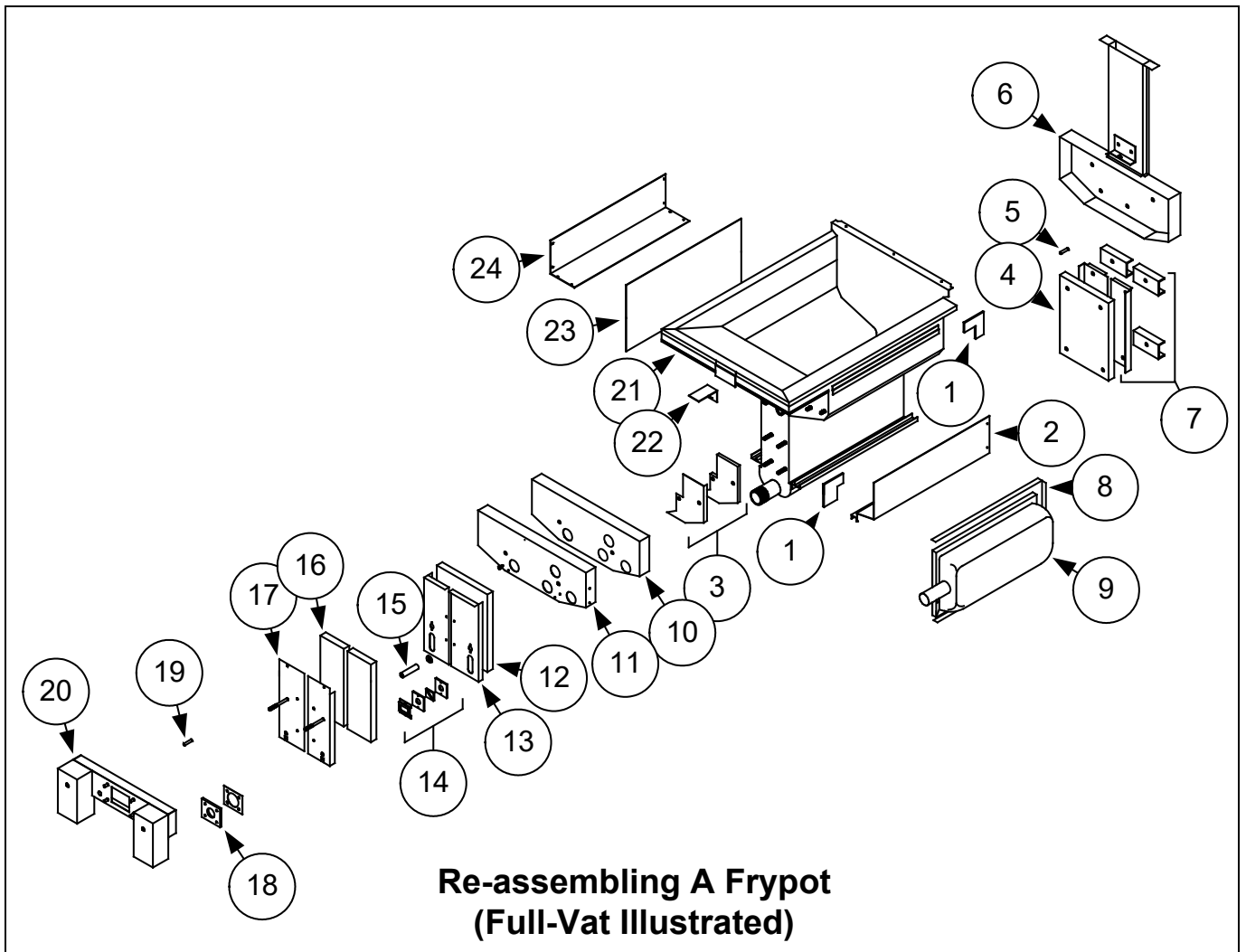

Figure 21

1.15 Troubleshooting and Problem Isolation

Because it is not feasible to attempt to include in this manual every conceivable problem or trouble condition that might be encountered, this section is intended to provide technicians with a general knowledge of the broad problem categories associated with this equipment, and the probable causes of each. With this knowledge, the technician should be able to isolate and correct any problem encountered.

Problems you are likely to encounter can be grouped into six categories:

1. Ignition or Heating failure
2. Improper burner function
3. Improper temperature control
4. Controller or board malfunctions
5. Filtration malfunctions
6. Leakage

The probable causes of each category are discussed in the following sections. A series of Troubleshooting Guides is also included at the end of the chapter to assist in solving some of the more common problems.

1.15.1 Heating (Ignition) Failure

Heating (ignition) failure occurs when the ignition module fails to sense a flame within the 4-second time delay period and locks out. When this happens, the module sends 24 VAC through the interface board alarm circuit to the controller.

FQ4000 controllers display **"HEATING FAILURE"**.

The three primary reasons for heating failure, listed in order of probability, are problems related to:

1. Dirty Oil Level [OIB (Oil Is Back)] sensor (if installed)
2. Gas and/or electrical power supplies
3. Electronic circuits
4. Gas valve

PROBLEMS RELATED TO THE OPTIONAL OIL LEVEL [OIB (OIL IS BACK)] SENSOR

The main indicators of this are that the fryer may light intermittently or fail to light. A visual clue is the OIB sensor is dark and caramelized with oil. Regular cleaning of the OIB sensor prevents this issue. See OIB troubleshooting in Section 1.21.5.1.

PROBLEMS RELATED TO THE GAS AND/OR ELECTRICAL POWER SUPPLIES

The main indicators of this are that an entire battery of fryers fails to light and/or there are no indicator lights illuminated on the fryer experiencing heating failure. Verify that the quick disconnect fitting is properly connected, the fryer is plugged in with connector twisted and locked, the main gas supply valve is open, and the circuit breaker for the fryer electrical supply is not tripped.

PROBLEMS RELATED TO THE ELECTRONIC CIRCUITS

If gas and electrical power are being supplied to the fryer, the next most likely cause of heating failure is a problem in the 24 VAC circuit. Verify that the oil level sensor is working properly. Refer to Section 1.16.1.

TROUBLESHOOTING THE 24 VAC CIRCUIT.

Some typical causes of heating failure in this category include a defective sensing wire in the ignitor assembly, a defective module, a defective ignition wire, and a defective ignitor.

Occasionally, a heating failure situation occurs in which all components appear to be serviceable and the microamp reading is within specification, but the unit nevertheless goes into heating failure during operation. The probable cause in this case is an intermittent failure of an ignition module. When the unit is opened up for troubleshooting, the module cools down enough to operate correctly; however, when the unit is again closed up and placed back into service the module heats up and fails.

PROBLEMS RELATED TO THE GAS VALVE

If the problem is not in the 24 VAC circuit, it is most likely in the gas valve, itself. Before replacing the gas valve, refer to Section 1.16.2 **TROUBLESHOOTING THE GAS VALVE.**

1.15.2 Improper Burner Function

With problems in this category, the burner ignites but exhibits abnormal characteristics such as “popping,” dark spots on the burner ceramics, fluctuating flame intensity, and flames shooting out of the flue.

“**Popping**” indicates delayed ignition. In this condition, the main gas valve is opening but the burner is not immediately lighting. When ignition does take place, the excess gas “explodes” into flame, rather than smoothly igniting.

The primary causes of popping are:

- Incorrect or fluctuating gas pressure
- Defective or incorrectly adjusted combustion air blower
- Inadequate make-up air
- Cracked burner tile (typically causes a very loud pop).
- Heat-damaged controller or ignition module
- Cracked ignitor or broken ignition wire
- Defective ignition module

If popping occurs only during peak operating hours, the problem may be incorrect or fluctuating gas pressure. Verify that the incoming gas pressure (pressure to the gas valve) is in accordance with the appropriate CE or Non-CE Standard and that the pressure remains constant throughout all hours of usage. Refer to Section 1.12, **Checking the Burner Manifold Gas Pressure** in this manual for the procedure for checking the pressure of gas supplied to the burner and the recommended pressures.

If popping is consistent during all hours of operation, the most likely cause is an insufficient air supply. Check for “negative pressure” conditions in the kitchen area. If air is flowing into the kitchen area, this indicates that more air is being exhausted than is being replenished and the burners may be starved for air.

If the fryer’s gas and air supplies are correct, the problem is most likely with one of the electrical components. Examine the ignition module and controller for signs of melting, distortion, and/or discoloration due to excessive heat build-up in the fryer (this condition usually indicates improper flue performance). A melted or distorted ignition module is automatically suspect and should be replaced; however, unless the condition causing excessive heat is corrected, the problem is likely to recur.

Verify that the ignition wire is tightly connected at both ends and free of obvious signs of damage. Again, if damage is due to excessive heat in the fryer, that problem must also be corrected. Check for proper operation by disconnecting the wire from the ignitor (spark plug), inserting the tip of a screwdriver into the terminal. With the insulated handle of the screwdriver, hold the shaft near the frame of the fryer as the power switch is placed in the ON position. A strong, blue spark should be generated for at least four seconds.



Make sure you are holding the insulated handle of the screwdriver and not the blade. The sparking charge is approximately 25,000 volts.

Examine the ignitor (spark plug) for any signs of cracking. A cracked ignitor must be replaced.

If all other causes have been ruled out, examine the burner tiles for any signs of cracking. If cracking is found, the burner must be replaced.

Fluctuating flame intensity is normally caused by either improper or fluctuating incoming gas pressure but may also be the result of variations in the kitchen atmosphere. Verify incoming gas pressure in the same way as for “popping,” discussed in the preceding paragraphs. Variations in the kitchen atmosphere are usually caused by air conditioning and/or ventilation units starting and stopping during the day. As they start and stop, the pressure in the kitchen may change from positive or neutral to negative, or vice versa. They may also cause changes in airflow patterns that may affect flame intensity.

Dark spots on the burner tiles are the result of an improper air/gas mixture. Adjust the combustion air blower to reduce the amount of air in the mixture to correct this problem.

Flames shooting out of the flue are usually an indication of negative pressure in the kitchen. Air is being sucked out of the burner enclosure and the flames are literally following the air. If negative pressure is not the cause, check for high burner manifold gas pressure in accordance with the procedures in Section 1.12.

An **excessively noisy burner**, especially with **flames visible above the flue opening**, may indicate that the gas pressure is too high, or it may simply be that the gas valve vent tube is blocked. If the incoming gas pressure is correct and the vent tube is unobstructed, the gas valve regulator is probably defective.

Occasionally a burner may apparently be operating correctly, but nevertheless the fryer has a **slow recovery rate** (the length of time required for the fryer to increase the oil temperature from 250°F to 300°F (121°C to 149°C)). The primary causes of this include an over-filled frypot, a dirty or out-of-adjustment combustion air blower, low burner manifold pressure, and/or damaged burner tiles. Adding oil to the frypot during the recovery process will also cause a slow recovery rate.

If these causes are ruled out, the probable cause is a misadjusted gas valve regulator. Refer to Section 1.12, **Checking the Burner Manifold Gas Pressure**, for the gas valve adjustment procedure.

1.15.3 Improper Temperature Control

Temperature control, including the melt cycle, is a function of several interrelated components, each of which must operate correctly. The principal component is the temperature probe. Other components include the smart interface board, the controller itself, and the ignition module.

Improper temperature control problems can be categorized into melt cycle problems and failure to control at setpoint problems.

MELT CYCLE PROBLEMS

Initiation of the melt cycle with FQ4000 controllers is automatic. Problems may originate from the controller itself, the temperature probe, or a malfunctioning heat relay on the SIB (Smart Interface Board) or the SIB (Smart Interface Board).

FAILURE TO CONTROL AT SETPOINT

Problems in this category may be caused by the temperature probe, the SIB (Smart Interface Board), or the controller.

1.15.4 Controller Malfunctions

RECOVERY TIME

Recovery time – is a method of measuring a fryer’s performance. Put simply, it is the time required for the fryer to increase the oil temperature from 250°F to 300°F (121°C to 149°C). This range is used as a standard since ambient kitchen temperatures can affect the test if lower ranges are used.

The FQ4000 controller performs the recovery test each time the fryer warms up. An operator can view the results of the test any time the fryer is above the 300°F (149°C) point by pressing the ? button and then pressing the recovery button when the fryer is on. The test results will be displayed in minutes and seconds. The maximum acceptable recovery time for FQG30-T Series gas fryers is three minutes and fifteen seconds (3:15).

1.15.5 Filtration Malfunctions

The majority of filtration problems arise from operator error. One of the most common errors is placing the filter paper/pad on the bottom of the filter pan rather than over the filter screen.

Whenever the complaint is “the pump is running, but no oil is being filtered,” check the installation of the filter paper/pad, including that the correct size is being used. While you are checking the filter paper/pad, verify that the O-rings on the filter pan suction tube are present and in good condition. Missing or worn O-rings will allow the pump to suck air and decrease its efficiency. Also check the pre-filter. A plugged pre-filter (see Figure 22) can slow the flow of oil. Use the attached wrench to open (see Figure 23) and clean the pre-filter (see Figure 24). Ensure the pre-filter is tight to prevent air from entering the line and causing slow oil return.



Figure 22

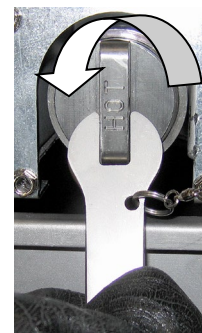

Figure 23



Figure 24

If the pump motor overheats, its thermal overload will trip, and the motor will not start until it is reset. If the pump motor does not start, press the red reset switch located on the front of the motor. If the pump starts, something caused the motor to overheat. It may be attributed to several frypots in a large battery of fryers being filtered one after the other and the pump overheated. Letting the pump cool down for at least a half-hour is all that is required in this case. More often, the pump overheated for one of the following reasons:

- Shortening that remained in the pan after previous filtering solidified in the suction tube recess in the bottom of the pan or the suction tube, itself. Adding hot oil to the pan and waiting a few minutes will usually correct this

problem. A flexible wire can be used to clean out the suction tube and the recess in the bottom of the pan. **NEVER** use compressed air to blow solidified shortening out of the suction tube!

- The operator attempted to filter oil that was not heated. Cold oil is thicker and causes the pump motor to work harder and overheat.

If the motor hums but the pump does not rotate, there is a blockage in the pump. Incorrectly sized or installed paper/pad will allow food particles and sediment to pass through the filter pan and into the pump. When sediment enters the pump, the gears can bind up and cause the motor to overload, tripping the thermal overload. Solidified shortening in the pump will also cause it to seize, with similar results.

A pump seized by debris or hard shortening can usually be freed by manually moving the gears with a screwdriver or other instrument as illustrated on the following page. **Ensure power to the pump motor is off before trying this.**

1. Disconnect power to the filter system.
2. Remove the input plumbing from the pump.
3. Use a screwdriver to manually turn the gears (see Figure 25).
 - Turning the pump gears backwards will release a hard particle and allow its removal.
 - Turning the pump gears forward will push softer objects and solid shortening through the pump and allow free movement of the gears.

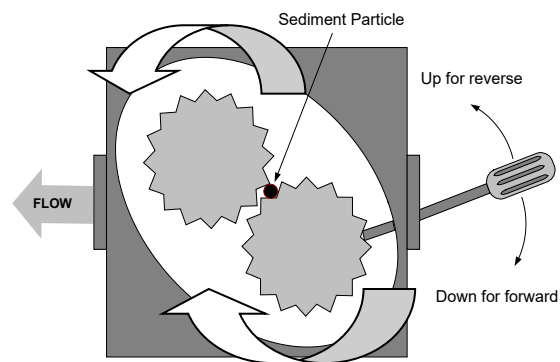

Figure 25

Internal Oil Flow is illustrated by large arrows.

Filter paper/pads that are installed incorrectly will also allow food particles and sediment to pass through and clog the suction tube recess on the bottom of the filter pan or the suction tube, itself. Particles large enough to block the suction tube recess or the suction tube may indicate that the crumb tray is not being used.

1.15.6 Leakage

Leakage of the frypot will usually be due to improperly sealed high-limit thermostats, RTD's, temperature probes, other sensors and drain fittings. When installed or replaced, each of these components must be sealed with Loctite® PST56765 sealant or equivalent to prevent leakage. In very rare cases, a leak may develop along one of the welded edges of the frypot. When this occurs, the frypot must be replaced.

If the sides or ends of the frypot are coated with oil, the most likely cause is spillage over the top of the frypot rather than leakage.

The clamps on the rubber boots that hold the drain tube sections together may loosen over time as the tubes expand and contract with heating and cooling during use. Also, the boot itself may be damaged. If the section of drain tube connected to the drain valve is removed for any reason, ensure that its rubber and clamps are in good condition and properly fitted around the drain tube when it is reinstalled. Also, check to ensure that the drain tube runs downward from the drain along its whole length and has no low points where oil may accumulate.

1.16 Troubleshooting Guides

The troubleshooting guides on the following pages are intended to assist service technicians in quickly isolating the probable causes of equipment malfunctions by following a logical, systematic process. An additional set of operators troubleshooting guides are contained in Chapter 7 of the FQG30-T Series Installation and Operation Manual. It is suggested that service technicians thoroughly familiarize themselves with both sets.

1.16.1 Troubleshooting the 24 VAC Circuit

Prior to checking for problems associated with the 24 VAC circuit, ensure that the unit is connected to a power supply, and the controller is on and is calling for heat (heat indicator appears and displays PRE-HEAT).

NOTE: All voltage measurements must be made within **4 seconds** of the unit calling for heat. If unit does not fire within **4 seconds**, ignition modules will lock out and controller must be turned off, then on to reset.

DO NOT CHECK WITH HARNESES UNPLUGGED AS SHORTING THE PINS MAY OCCUR WHICH WILL DAMAGE THE BOARD.

The following processes will assist you in troubleshooting the 24 VAC circuit and ruling it out as a probable cause:

- **24 VAC is not present on the interface board J1 pin 1.**
 1. If LED's 2, 4 and 6 are not continually lit, the probable causes are a loose or blown fuse, failed 24 VAC transformer, or failed wiring between the transformer and interface board.
- **24 VAC is present on interface board J1 pin 1.**
 1. If 24 VAC is not present across the gas valve main coil (MV terminals), probable causes are an open high-limit thermostat or a failed wire between the interface board and gas valve. Be sure to check both valves on dual vat units.
 - a. Check continuity of high-limit thermostat. If it is zero, problem is in wiring.
 2. If 24 VAC is present on J2 pin 1, the probable causes are failed ignition module(s) or a failed interface board. Replace the questionable ignition module with one known to be good to isolate the cause.
 3. If 24 VAC is present across the gas valve main coil (MV terminals), the 24 VAC circuit is working and the problem may be with the gas valve. Be sure to check both valves on dual vat units.
 4. If LED 3 is not continually lit with the controller in the ON position, the probable cause is a defective latch relay.
 5. If LED 1 is not continually lit with the controller in the ON position and calling for heat, the probable cause is a defective heat relay.

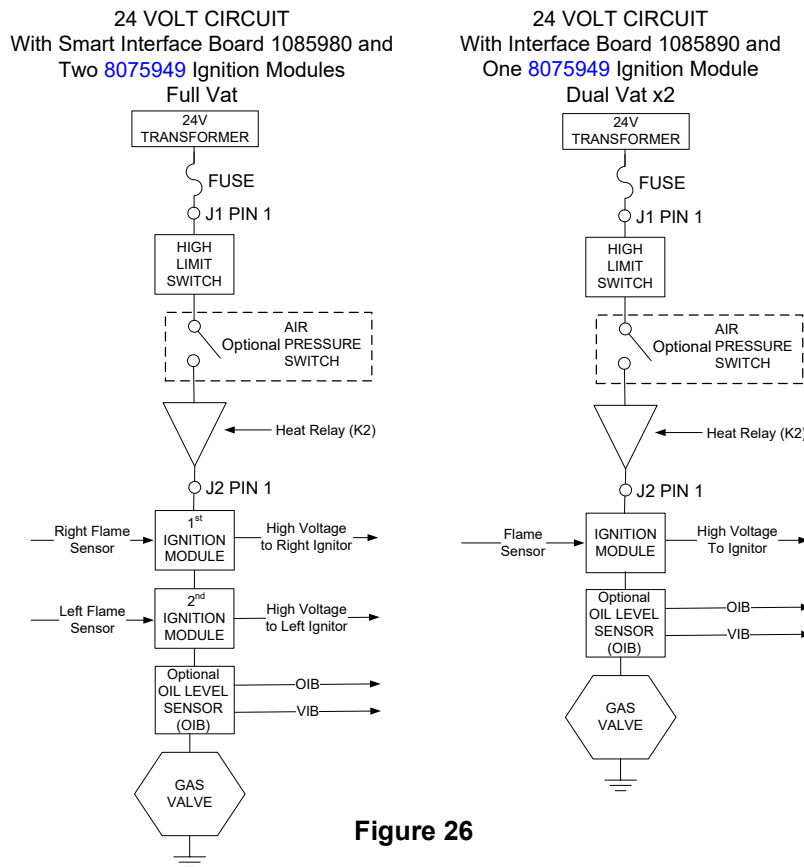

Figure 26

1.16.2 Troubleshooting the Gas Valve

Prior to checking for problems associated with the gas valve, ensure that the unit is calling for heat. Also, for non-CE units, verify that the gas valve is in the ON position.

The following processes will assist you in troubleshooting the gas valve and ruling it out as a probable cause:

- If 24 VAC is not present across gas valve main coil, the probable cause is the 24 VAC circuit. Refer to the 24 VAC circuit troubleshooting guide in section 1.16.1.
- If 24 VAC is present across gas valve main coil, check the incoming gas pressure and compare to the tables in section 1.12.
 1. If incoming gas pressure *is not* correct, the probable cause is a problem with the gas supply to fryer.
 2. If incoming gas pressure *is* correct, check the burner manifold gas pressure and compare it to the tables in section 1.12.
 - a. If burner manifold gas pressure *is not* correct, the probable cause is an improperly adjusted or failed gas valve. Adjust the valve by following the procedure “Check Burner Manifold Pressure” in Section 1.12 of this manual. If the valve cannot be adjusted, replace it.
 - b. If outgoing gas pressure *is* correct, the gas valve is okay.

1.16.3 Troubleshooting the Temperature Probe



Disconnect the temperature probe from the SIB board before testing temperature probe resistances to avoid invalid readings

Prior to checking for problems associated with the temperature probe, inspect the probe body for damage while it is still in the frypot. Remove and replace the probe if it is bent, dented, or cracked. Also, inspect leads for fraying, burning, breaks, and/or kinks. If found, replace the probe.

The following processes will assist you in troubleshooting the gas valve and ruling it out as a probable cause:

Before testing the probe, determine the temperature of the cooking oil using a thermometer or pyrometer placed at the tip of the questionable probe.

Unplug the temperature probe from the SIB board to test the resistance of the probe.

- **If resistance through the temperature probe is not approximately equal to that given in the Probe Resistance Chart in section 1.17 for the corresponding temperature, the probe has failed and must be replaced.**
- **If resistance through temperature probe is approximately equal to that given in the Probe Resistance Chart for the corresponding temperature, measure the resistance through each of the previously tested pins to ground.**
 1. If resistance *is not* 5 mega-Ohms or greater in each pin, the probe has failed and must be replaced.
 2. If resistance *is* 5 mega-Ohms or greater in each pin, the probe is okay.

1.16.4 Replacing the Reset Switch Relay

Disconnect the fryer from the electrical power supply. Relocate the fryer and remove the transformer box in the rear of the fryer. Replace the relay marking the wires to ease reassembly. Once replaced, reconnect the power.

1.17 Probe Resistance Chart

Probe Resistance Chart																	
For use with FQG30-T fryers manufactured with Minco RTD probes only.																	
F	OHMS	C	F	OHMS	C	F	OHMS	C	F	OHMS	C	F	OHMS	C	F	OHMS	C
60	1059	16	130	1204	54	200	1350	93	270	1493	132	340	1634	171			
65	1070	18	135	1216	57	205	1361	96	275	1503	135	345	1644	174			
70	1080	21	140	1226	60	210	1371	99	280	1514	138	350	1654	177			
75	1091	24	145	1237	63	215	1381	102	285	1524	141	355	1664	179			
80	1101	27	150	1247	66	220	1391	104	290	1534	143	360	1674	182			
85	1112	29	155	1258	68	225	1402	107	295	1544	146	365	1684	185			
90	1122	32	160	1268	71	230	1412	110	300	1554	149	370	1694	188			
95	1133	35	165	1278	74	235	1422	113	305	1564	152	375	1704	191			
100	1143	38	170	1289	77	240	1432	116	310	1574	154	380	1714	193			
105	1154	41	175	1299	79	245	1442	118	315	1584	157	385	1724	196			
110	1164	43	180	1309	82	250	1453	121	320	1594	160	390	1734	199			
115	1174	46	185	1320	85	255	1463	124	325	1604	163	395	1744	202			
120	1185	49	190	1330	88	260	1473	127	330	1614	166	400	1754	204			
125	1195	52	195	1340	91	265	1483	129	335	1624	168	405	1764	207			

1.18 ATO (Automatic Top-off) and Filtration Service Procedures

The automatic top-off system is activated when the oil level falls below the top sensor in the front of the frypot. The signal is sent to the FIB (Filter Interface Board) which sends a signal to the VIB (Valve Interface Board) to engage the return actuator to the frypot and turn on the ATO pump. The pump draws oil from the JIB (Jug In Box) through the rear return manifold into the rear of the frypot. Once the oil level has satisfied the sensor, the pump turns off and the actuator closes. The ATO function only operates when the vat is in idle state. If a cook, filter or other operation starts, the ATO function is cancelled.

The FIB (Filter Interface Board) also oversees and controls filtration and bulk oil functions. It receives and sends data over the CAN (Controller Area Network) to and from various sensors, boards and controllers. It activates the filtration cycle sending information to the VIB (Valve Interface Board) boards controlling when actuators should open and close.

The FIB board is located inside the box, behind the oil reservoir (see Figure 29). The FIB box may differ in appearance depending on date of manufacture. The power for the FIB board, the filter pump relay and top off pump is supplied from the 24VDC power supply in the FIB box. The 24VDC power supply also provides power, which passes through the FIB board to the VIB board, to the rotary actuators. The power for the VIB board microprocessor is supplied from the SIB.

The 24VAC transformer powers the fresh oil solenoid for bulk oil.

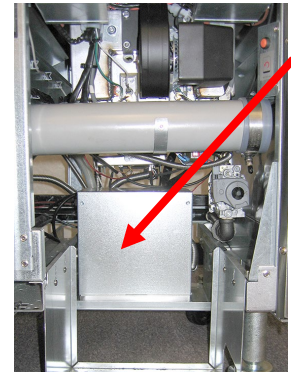

Figure 29

1.18.1 Auto Top Off Troubleshooting

Problem	Probable Causes	Corrective Action
Fryer tops off cold.	Incorrect setpoint.	Ensure setpoint is correct.
No power to FIB board	A. J1 connection unplugged. B. Power supply malfunction.	A. Check to ensure J1 on front of FIB board is fully locked into connector. B. Check that proper voltage is present at the power supply. See table in section 1.18.4.

Problem	Probable Causes	Corrective Action
<p>FQ4000 displays E64 - FILTRATION INTERFACE BOARD FAILURE - FILTRATION AND TOP OFF DISABLED - CALL SERVICE</p>	<p>A. Bad Connection. B. FIB Board power loss. C. FIB board failure.</p>	<p>A. Enter the INFO mode, and select SOFTWARE, review the FIB software status. If FIB: 00.00.000 is shown, the communication is lost between the FIB. B. Cycle power off for 60 seconds or longer using the master power reset switch. C. Repeat step A to check if a software version is shown other than zeros. If zeros are still present, skip to step D. D. Perform an FIB 2 RESET from the SERVICE - SERVICE menu. E. Repeat step A to check if a software version is shown other than zeros. If zeros are still present, skip to step F. F. Ensure CAN connections between the SIB board on far right vat and FIB board are secure. (Pressing the ? button shall display the FIB software version. If a software version of V00.00.000 is displayed and the FIB has power, a communication issue may be the cause). G. Repeat step A to check if a software version is shown other than zeros. If zeros are still present, skip to step H. H. Ensure CAN connections between the SIB board vat 1 to SIB board vat 2 to SIB board vat 3 are all secure. Note: If the error is only showing on vat 1 there is a communication break between vat 1 & 2. If the error is showing up on vat 1 and 2 then the error is in between vat 2 & 3. If the error is showing on all pots there is connection issue from vat 3 or higher to the FIB board; or the board is not getting power; or the board is not operational any longer and needs to be replaced. I. Repeat step A to check if a software version is shown other than zeros. If zeros are still present, skip to step J. J. Review the remote logger connection at the back of the fryer and insure the cabling to the remote monitor has not been damaged. If damaged, remove the cable and install the terminator into the wire harness connection (terminator zip tied to the cable mounting bracket). K. If the terminator was installed, repeat steps A thru E to see if communication is reestablished. If zeros are still present in INFO - SOFTWARE-FIB, move to step L. L. Power to the FIB board has been lost. Ensure there is correct voltage to the FIB power supply and from the FIB power supply. Restore power to the board and clear any service required errors. Replace FIB power supply. If the FIB board has a red led illuminated, power is present at the FIB board. M. If power is supplied at the FIB board in step L and all of the other steps above still reflect the E64, then replace FIB board. After replacing the FIB board, reset the system by powering the entire battery down for 60 seconds.</p>

Problem	Probable Causes	Corrective Action
Frypots won't top off.	<ul style="list-style-type: none"> A. Empty oil reservoir. B. ATO lines/pump obstruction. C. ATO probe temperature lower than setpoint. D. Oil is too cold. E. Bad Connection F. SIB, VIB or FIB power loss G. Failed power supply/harness. H. ATO pump failed. I. Failed FIB board. J. Failed VIB board. K. Vat isn't in idle state. 	<ul style="list-style-type: none"> A. Ensure oil reservoir has oil. B. Ensure the lines/ATO pump is not obstructed. C. Check to see that fryer is heating. Fryer temperature must be at setpoint. With ATO probe covered in oil, press the "?" button. Press the down arrow. Press Software Version. Press the down arrow and ensure actual vat temperature and ATO RTD temperature are relatively close. Unplug the ATO probe from the SIB board and check ATO probe resistance. If probe is bad, replace the probe. D. Ensure that the oil in the oil reservoir is above 70°F (21°C). E. Press the information (?) button; press the down arrow; press the SW version button. Ensure the SIB, VIB and FIB software versions appear. If not, the connection between the VIB and the SIB board or between the SIB and FIB may be bad. Ensure the P-BUS connectors are tight between VIB (J2) and SIB (J9 or J10) or between SIB (J7 or J8) and FIB (J3 or J4) boards. F. Power to the SIB, VIB or FIB has been cut off. Restore power to the board and clear any service required errors. G. Ensure power supply in FIB box is functioning properly. Ensure all harnesses are plugged securely into place. H. Ensure ATO pump is operational. Check voltage to ATO pump. Replace the ATO pump if defective. I. Check FIB for proper voltages using the pin position chart found in section 1.18.4. If FIB found defective, replace FIB board. <u>DO NOT CHECK WITH HARNESES UNPLUGGED AS SHORTING THE PINS MAY OCCUR WHICH WILL DAMAGE THE BOARD.</u> J. Check VIB for proper voltages using pin position chart in section 1.21.2. If VIB found defective, replace VIB board. <u>DO NOT CHECK WITH HARNESES UNPLUGGED AS SHORTING THE PINS MAY OCCUR WHICH WILL DAMAGE THE BOARD.</u> K. The auto top off function only operates when the vat is in idle state. If a cook, filter or other operation starts, the ATO function is cancelled.
One vat tops off but other vats fail to top off.	<ul style="list-style-type: none"> A. Loose wire connection. B. Actuator issue. C. Actuator connector issue. 	<ul style="list-style-type: none"> A. Ensure all wiring harnesses are securely connected to SIB and FIB board. B. Check return actuator to ensure actuator is functional. C. Ensure return actuator connector is fully seated into VIB board.
The yellow low oil reservoir indicator won't illuminate.	<ul style="list-style-type: none"> A. ATO probe issue B. Dirty ATO probe C. Probe connection 	<ul style="list-style-type: none"> A. With ATO probe covered in oil, press the "?" button. Press the down arrow. Press Software Version. Press the down arrow and ensure actual vat temperature and ATO RTD temperature are relatively close. B. Ensure the ATO probe is clean and sediment is not present in probe cavity. C. Ensure the ATO probe is properly connected to SIB board.
Incorrect vat tops off.	<ul style="list-style-type: none"> A. Wired incorrectly. B. Flex lines connected to wrong vat. 	<ul style="list-style-type: none"> A. Check wiring. Ensure the ATO probes are connected to correct vat and harness positions. B. Ensure the correct flex lines are connected to correct vat.

Problem	Probable Causes	Corrective Action
One vat doesn't top off.	A. Filter error exists. B. Actuator, pump, loose connection, RTD or FIB issue.	A. Clear filter error properly. When "CHANGE FILTER PAD YES/NO" is displayed, do NOT press any button until the pan has been removed for at least thirty seconds . After thirty seconds the controller returns to OFF or previous display. B. Check actuator, ATO pump, FIB board, wire connections and RTD.
FQ4000 displays E29 TOP OFF PROBE FAILURE – CALL SERVICE	A. Shorted or Open ATO RTD probe B. Bad Connection	A. With ATO probe covered in oil, press the "?" button. Press the down arrow. Press Software Version. Press the down arrow and ensure actual vat temperature and ATO RTD temperature are relatively close. If temperature reading is missing, unplug the ATO probe from the SIB board and check ATO probe resistance. If probe is bad, replace the probe. B. Ensure ATO probe is connected properly to SIB board. Ensure that the connector is terminated properly.

1.18.2 Filtration Troubleshooting

Problem	Probable Causes	Corrective Action
Quick Filter or Clean and Filter won't start.	A. Filter pan out of position. B. Oil level too low. C. Oil temperature is too low (OIL TOO COLD display). D. Filter relay has failed. E. Filter motor thermal switch is tripped. F. Filter in recipe setup is set to OFF (Auto only). G. Filter After set to "0". H. Filtration Lockout set for ENABLED. I. Error in system.	A. Ensure filter pan is fully inserted into fryer. If the controller displays a "P" the pan is not fully engaged into the pan switch. B. Ensure the oil level is above the top oil level sensor. C. Ensure the oil temperature is above 310F (154C). D. Replace filter relay with part number 807-4482 24VDC relay if defective. E. Press filter motor thermal switch. F. Set Filter in recipe setup to ON. G. Set Filter After to required number of cooks for filter prompt. H. Set Filtration Lockout for DISABLED. I. Ensure that no error exist in system. Check error log for errors. Power cycle the fryer.
No power present at the FIB board	See No Power to FIB board in section 1.18.1.	See No Power to FIB board in section 1.18.1.
Fryer filters after each cook cycle.	Filter after setting incorrect.	Change or overwrite the filter after setting by re-entering the filter after value in Manager Settings, Filter Attributes in section 4.8 in the FQG30-T IO Manual.
FIB will not clear error.	Error remains in non-volatile memory.	Press home button. Press service. Press service again. Enter 3000 and press check. Press down arrow button. Press FIB2 reset. Press yes. Press the check. Press home button to exit. Ensure that at CHANGE FILTER PAD the pan is out for at least 30 seconds to clear message.
FQ4000 displays FILTER BUSY.	A. Another filtration cycle or filter pad change is still in process. B. Filter interface board has not cleared checking system.	A. Wait until the previous filtration cycle ends to start another filtration cycle or until the FIB board has reset. This may take up to one minute. Change filter pad if prompted. B. Wait 15 minutes and try again. If filter busy is still displayed with no activity, ensure the filter pan is empty and remove and restore ALL power to the fryer.
Drain valve or return valve stays open.	A. Valve Interface Board has failed. B. Actuator has failed. C. Power supply failed.	A. Ensure that the VIB and FIB board software versions are present to indicate communication. B. Ensure the actuator is properly connected and functioning. C. Ensure power supply is functioning correctly in FIB box. Check VIB for proper voltages using pin position chart in section 1.21.2.

Problem	Probable Causes	Corrective Action
Filter pump won't start or pump stops during filtering.	<ul style="list-style-type: none"> A. Power cord is not plugged in or circuit breaker is tripped. B. Pump motor has overheated causing the thermal overload switch to trip. C. Blockage in filter pump. 	<ul style="list-style-type: none"> A. Verify that the power cord is fully plugged in and the circuit breaker is not tripped. B. If the motor is too hot to touch for more than a few seconds, the thermal overload switch has probably tripped. Allow the motor to cool at least 45 minutes then press the Pump Reset Switch. C. Ensure filter pump is functioning properly and no blockages exist.
FQ4000 displays INSERT PAN.	<ul style="list-style-type: none"> A. Filter pan is not fully set into fryer. B. Missing filter pan magnet. C. Defective filter pan switch. 	<ul style="list-style-type: none"> A. Pull filter pan out and fully reinsert into fryer. Ensure controller does not display "P". B. Ensure the filter pan magnet is in place and replace if missing. C. If the filter pan magnet is fully against the switch and controller continues to display INSERT PAN or "P", switch is possibly defective.
Filter Pump runs, but oil return is very slow.	<ul style="list-style-type: none"> A. Clogged filter pad/paper. B. Improperly installed or prepared filter pan components. C. Pre-filter screen may be clogged or not fully tightened. 	<ul style="list-style-type: none"> A. Ensure the filter is not clogged. If so replace the filter. B. Remove the oil from the filter pan and replace the filter pad, ensuring that the filter screen is in place under the pad. Verify, if using a pad, that the rough side is facing up. Verify that O-rings are present and in good condition on filter pan connection fitting. C. Clean pre-filter and ensure it is tightened with the attached wrench.
FQ4000 displays IS DRAIN CLEAR?	<ul style="list-style-type: none"> A. Clogged drain or Oil Level Sensor (OIB) is malfunctioning. B. Dirty oil level sensor (OIB). 	<ul style="list-style-type: none"> A. The oil level sensor (OIB) detects that oil is not draining possibly due to clogged drain. Ensure drain is not clogged. If drain is not clogged, see oil level sensor troubleshooting in section 1.21.5.1. B. Clean the oil level sensor (OIB).
FQ4000 displays E43 OIL SENSOR FAIL CALL SERVICE.	Oil sensor may have failed.	Ensure the OIB sensor is operating correctly.

1.18.3 Test Points on rear of FIB Box

1.18.3.1 12 pin connector on rear of FIB (Filter Interface Board) box (C7) (may differ due to date of manufacture).

Use these test pins to easily test these test points.

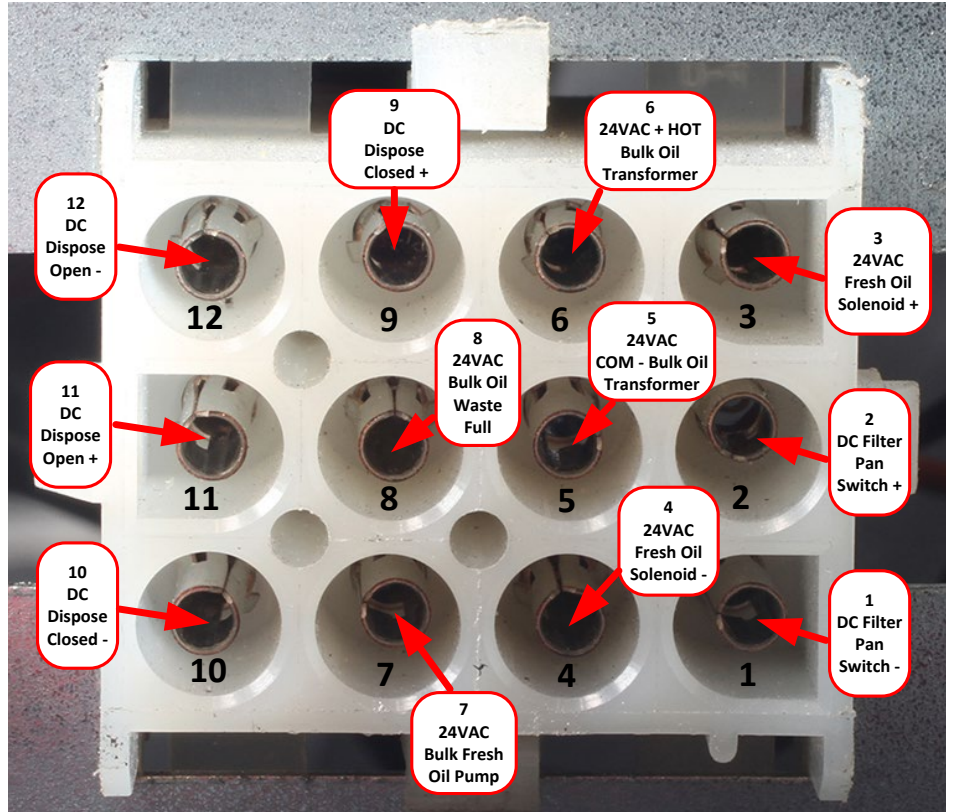

Figure 30

1.18.3.2 Connections on rear of FIB (Filter Interface Board) box (may differ due to date of manufacture).

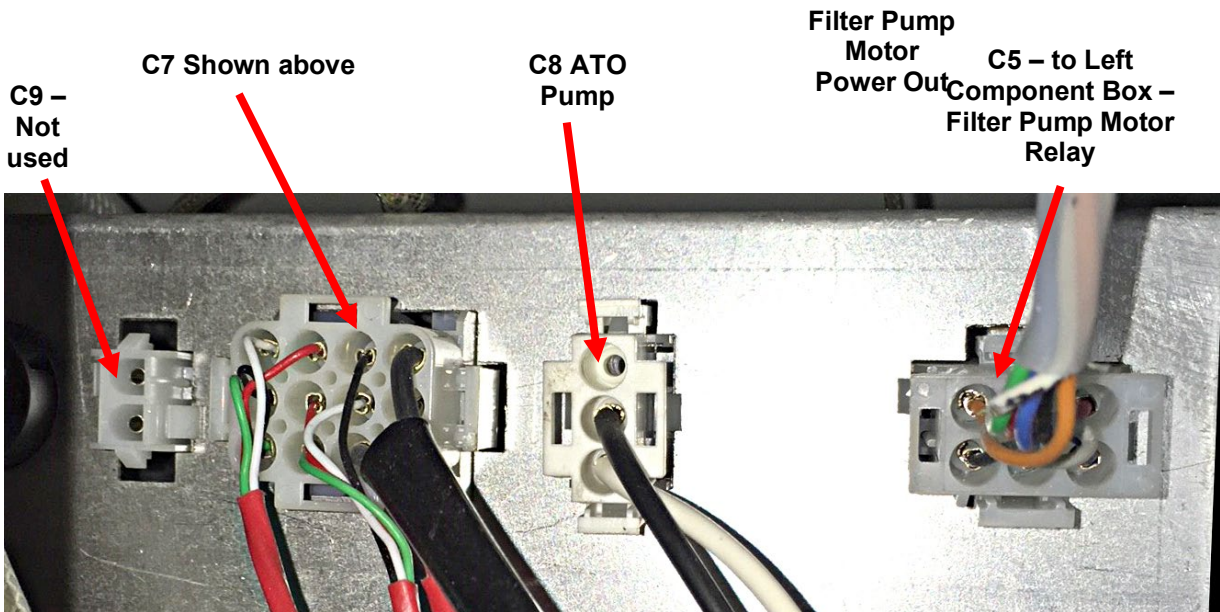

Figure 31

1.18.4 FIB (Filter Interface Board) Filtration and Top-off Pin Positions and Harnesses

NOTE: DO NOT CHECK WITH HARNESSES UNPLUGGED AS SHORTING THE PINS MAY OCCUR WHICH WILL DAMAGE THE BOARD.

Connect or	From/To	Harness #	Pin #	Function	Voltage	Wire Color		
J1	Input from Power Supply	8076240	1	Ground -		Brown		
			2	24VDC Input	+24VDC	Purple		
			3	Ground -		Brown		
			4	24VDC Input	+24VDC	Purple		
	JIB Reset Switch		5	Ground -		3.3VDC	Black	
			6	JIB Low Reset		3.3VDC	Red	
	Filter Pump Relay		9	Pump Motor +		24VDC	Purple	
			10	Pump Motor -		24VDC	Brown	
	Pan Switch		13	Pan Sw Ground -		3.3VDC	Red	
			14	Pan Sw +		3.3VDC	Red	
	ATO Pump		15	Pump Ground -		24VDC	Purple	
			16	ATO Pump		24VDC	Brown	
	Input from 24VAC Transformer		17	24VAC		24VAC	Orange	
			18	24VAC Ret		24VAC	Blue	
	To Bulk Fresh Oil JIB Add Solenoid		19	24VAC		24VAC	Black	
			20	24VAC Ret		24VAC	Black	
	Bulk connector rear of fryer		21	From bulk oil fresh transformer (Pin 1 on 9 pin)		24VAC	Orange	
			22	Common (Ret) (Pin 4 on 9 pin)			Blue	
			23	To bulk oil Fresh Oil Relay (Pin 3 on 9 pin)		24VAC	Orange	
			24	From bulk "Waste Tank Full Sensor" Test Pins 22 to 24 (Pin1 to Pin4 on 9 pin)		24VAC -Full 0VAC - Not Full	Orange	
	Waste Closed Switch		25	Closed Switch +		3.3VDC	Black	
			26	Closed Switch Ground -		3.3VDC	Black	
	Waste Open Switch		27	Open Switch +		3.3VDC	Black	
			28	Open Switch Ground -		3.3VDC	Black	
	Filter Pump Relay Contact Signal When Pump Is On		29	Filter Pump On Contact				
			30	Filter Pump On Contact				
	J2		24VDC Power Output from FIB to Far Right VIB Board (RJ45)	8075810	1	Ground		
					2	Ground		
					3	Ground		
					4	Ground		
5		Power			+24VDC			
6		Power			+24VDC			
7		Power			+24VDC			
8		Power			+24VDC			
J3	C-Bus from Far-Right SIB Board (RJ11)	8075551	1	5VDC	+5VDC			
			2	CAN High				
			3	CAN Low				
			4	Ground				
J4	C-Bus or Network Resistor (pins 2 & 3) (RJ11)	(8075632 resistor)	1	5VDC+	+5VDC			
			2	CAN High				
			3	CAN Low				
			4	Ground				

1.18.5 Replacing the FIB Board, Power Supply, Filter Pump Motor Relay or Transformer

Disconnect the fryer from the electrical power supply. Locate the FIB box (see Figure 29 in section 1.18), behind the oil reservoir. Remove the cover of the FIB box to expose the power supply, FIB board and SUI communication board (see Figure 32). The FIB box may differ in appearance depending on date of manufacture. Mark and unplug any wires or harnesses. Replace the defective component and reattach all wires or harnesses. Replace the cover. Once replaced, **CYCLE POWER TO ENTIRE FRYER SYSTEM**. See section 1.19.2 to reset control power. Check software version and if necessary, update the software. If a software update is necessary, follow the instructions to update the software in section 1.23.

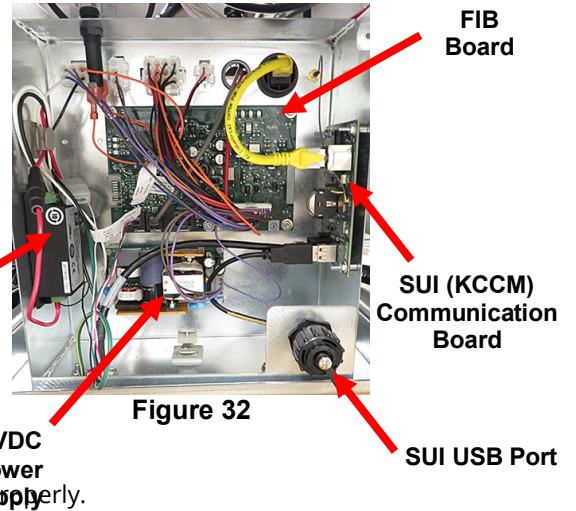

Press the information (?) button; press the down arrow; press the SW version button to verify software version of the FIB. If the FIB software version is not visible, the FIB may not be connected properly.

1.18.5.1 FIB (Filter Interface Board) LED's and Test Points

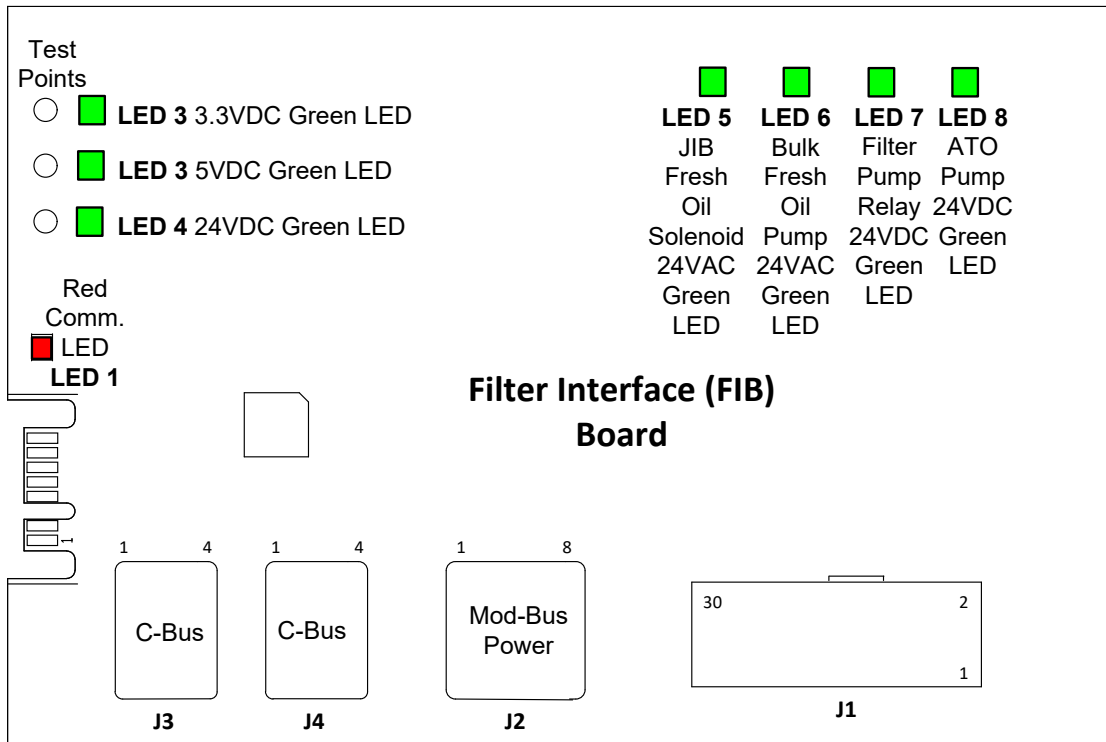

Figure 32a

1.18.6 Replacing the ATO Pump or Solenoid

Disconnect the fryer from the electrical power supply. Locate the ATO pump (see Figure 33), behind the FIB box. Mark and unplug any wires or harnesses. Press down from the top on the quick disconnects to release the plumbing (see Figure 34). The plumbing can be pulled from the pump. Loosen the four nuts attaching the pump to the pump tray. Disconnect the electrical connection. Replace the defective component and reverse above steps. Once replaced, reconnect the power.



Figure 33

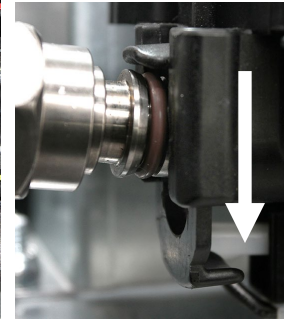

Figure 34

1.19 FIB (Filter Interface Board) Service Procedures

The controller has a service mode that allows manually opening of return and drain valves, manual operation of the filter pump motor and the ATO pump.

To access the mode follow these steps:

1. Press the Home button.
2. Press the Service button.
3. Press the Service button again.
4. Enter 3000 and press the checkmark.
5. Press Manual Filtration button.

The controller displays the current state of the valves and pump under the titles (see Figure 35). Pressing the buttons will perform the action inside the button.

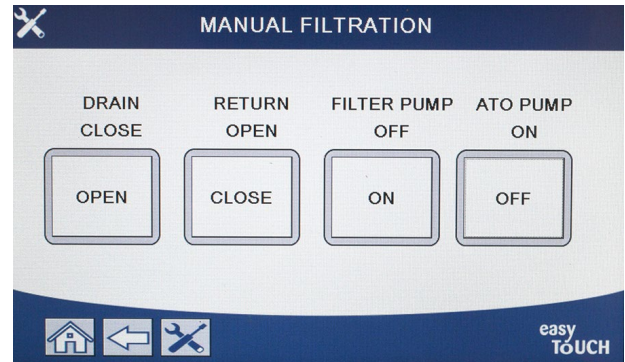

Figure 35

1.19.1 Manually Draining, Refilling, Filtering or Topping off using the Manual Filtration Mode

Pressing the drain button or the return button activates the drain or return valve for the associated vat. Pressing the filter pump button or ATO pump button activates the pumps. **NOTE: The pumps will not activate unless a return valve is opened to prevent deadheading of the pumps.**

Pressing the home button exits the manual filtration mode. Upon exiting the manual filtration mode, the controller will prompt to FILL VAT FROM PAN? YES/NO to ensure no oil is left in the filter pan. Follow the prompts to ensure all oil is returned to the vat.

1.19.2 Control Power Reset Switch

The control power reset switch, is a momentary rocker switch, located in the far-left fryer cabinet (see Figure 36), that resets all power to all the controllers and boards in the fryer. It is necessary to reset all power after replacing any controller or board and after any setup change. Press and hold the switch for at least **sixty (60) seconds** when resetting the control power to ensure power has sufficiently drained from boards.



Figure 36

1.20 Bulk Oil Service Issues

1.20.1 Bulk FIB Tests

These instructions may **NOT** be applicable to all bulk oil systems.

The FilterQuick-T™ fryer will **ONLY** operate with a three-pole float switch for waste oil. If a two-pole switch is used it may cause damage to the FIB board. The float switches are polarity specific which may short to ground and damage an FIB board.

AC voltage measurements from the bulk oil connector on rear of fryer:

Pin 1 to Pin 2 - 24 VAC.

Pin 1 to Pin 4 - 24 VAC when waste tank is full, 0 VAC when it is not full.

Pin 1 to Pin 3 - 24 VAC when bulk fresh oil add switch and pump is on, 0 VAC when it is off.

Troubleshooting

All return and drain valves should be closed and pump should be off while the FIB is resetting. If any of the valves or the pump is on during reset, the FIB board is bad, or wires are shorted.

Bulk fresh oil pump is not operating, or Oil Reservoir is not filling:

NOTE: DO NOT CHECK PINS WITH HARNESSES UNPLUGGED AS SHORTING THE PINS MAY OCCUR WHICH WILL DAMAGE THE BOARD.

Normal measurements (FIB C7 12-pin or rear of FIB box (J1 30-pin) connector with everything connected)

See section 1.20.5 to ensure that no other function is taking priority over adding oil to jug.

1. Reset the power; wait **60 seconds** and see if the valve opens.

With the Orange JIB (Oil Reservoir) button pressed:

2. Voltage at FIB board C7 from Pin 5 to Pin 6 (FIB board J1 from Pin 21 to Pin 22) should be 24 VAC; if not, check connections from bulk fresh oil 24VAC transformer and check transformer.
3. Voltage at FIB board C7 from Pin 6 to Pin 7 (FIB board J1 from Pin 21 to Pin 23) should be 24 VAC when filling JIB or vat; if not, the FIB board is bad or wires to pump relay are shorted or both.
4. Voltage at Fresh Add Pump Relay should be 24 VAC; if not, check wiring from FIB board. The relay is located on top of some fresh oil bulk systems.

Waste full signal:

Voltage at FIB board C7 Pin 5 to Pin 8 (FIB board J1 from Pin 22 to Pin 24) should be 24 VAC when full, 0 VAC when not full; if no voltage level change, the connection from bulk waste full switch or FIB board is bad.

1.20.2 Bulk Oil Wiring Connection behind Fryer

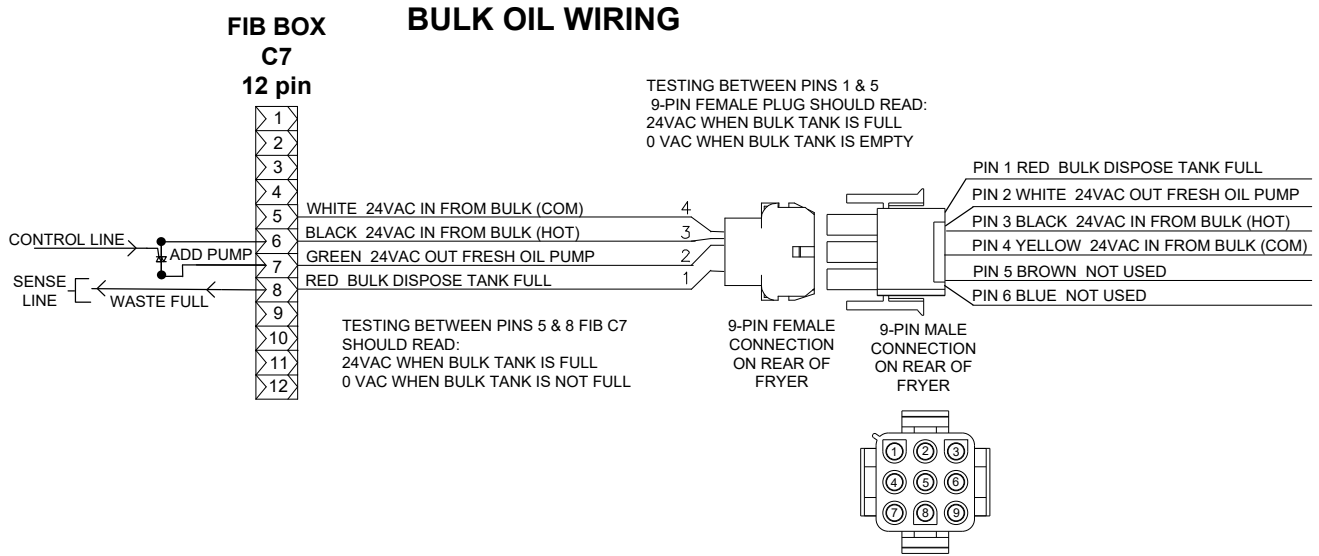

Figure 37

1.20.3 Frymaster FilterQuick-T Fryer and Bulk Oil System Plumbing Schematic

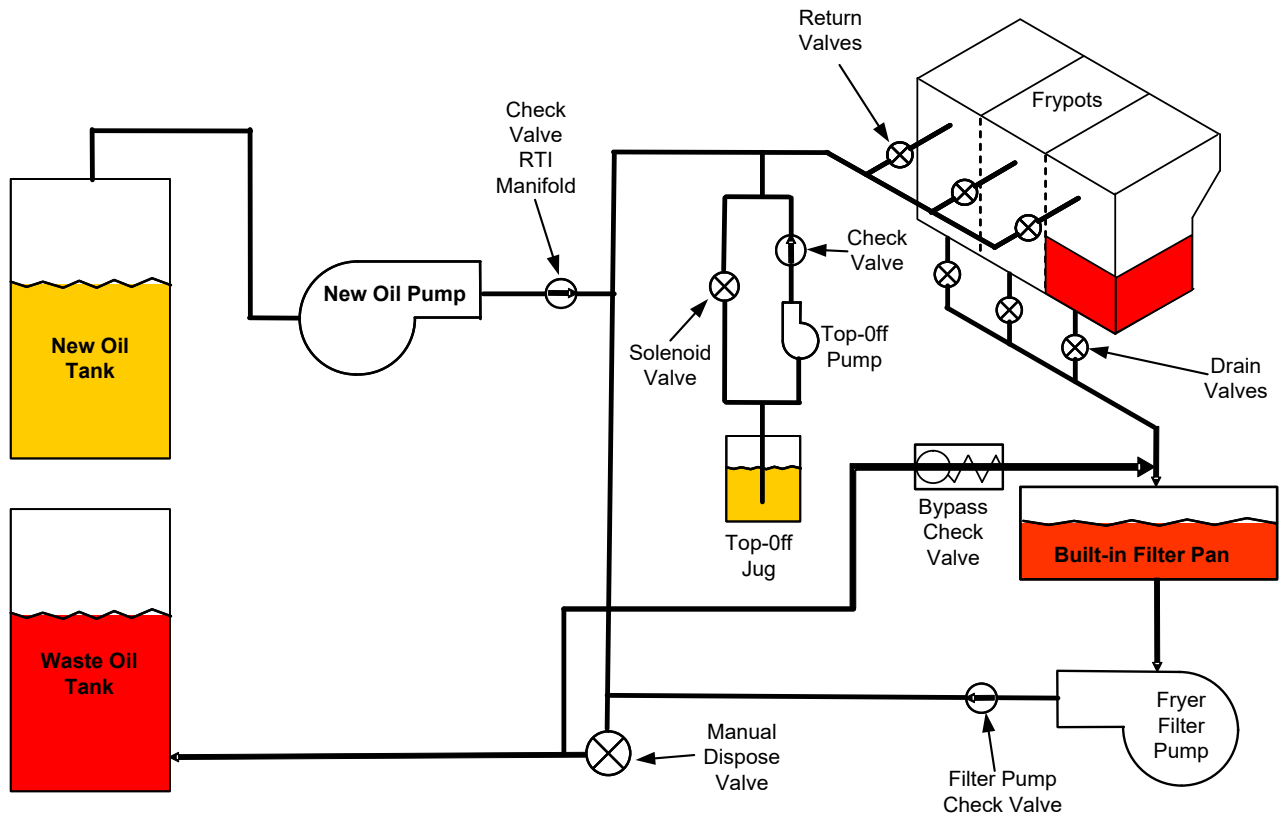

Figure 38

1.20.4 Bulk Test Quick Reference

1.20.4.1 Dispose to Waste, Refill Vat from Bulk



1. Press the filtration menu button.
2. Select LEFT VAT or RIGHT VAT for split vats.
3. Press the down arrow two (2) times.
4. Select DISPOSE.
5. "DISPOSE NOW? is displayed. *
6. Press the √ (check) button to dispose of oil in vat.
7. "REMOVE FILTER PAN" is displayed. Remove the filter pan.
8. "IS FILTER PAN EMPTY?" is displayed. Press the √ (check) button if the pan is empty and reinsert pan.
9. "START DISPOSE" is displayed with blue button. Press the blue button.
10. "DRAINING" is displayed.
11. "VAT EMPTY? is displayed.
12. Once the vat is empty, press the √ (check) button.
13. "CLEAN VAT COMPLETE? is displayed.
14. Press the √ (check) button.
15. "OPEN DISPOSE VALVE" is displayed.
16. Open dispose valve.
17. "DISPOSING" is displayed for four minutes.
18. "REMOVE PAN" is displayed.
19. Remove filter pan.
20. "IS PAN EMPTY? is displayed.
21. Press the √ (check) button if the filter pan is empty. Select "NO" if oil remains in the filter pan.
22. "INSERT PAN" is displayed.
23. Insert the filter pan.
24. "CLOSE DISPOSE VALVE" is displayed.
25. Close dispose valve.
26. "FILL VAT FROM BULK? is displayed.
27. Press the √ (check) button.
28. "START FILLING? PRESS AND HOLD" is displayed.
29. Press and hold the button to fill the vat.
30. RELEASE BUTTON WHEN FULL.
31. Release the button when the vat is full.
32. "CONTINUE FILLING" is displayed
33. Press the √ (check) button to continue filling or press "NO" to exit.

*NOTE: If the waste tank is full, the controller displays "BULK TANK FULL?" Call bulk waste provider.

1.20.4.2 Dispose to Waste



1. Press the filtration menu button.
2. Select LEFT VAT or RIGHT VAT for split vats.
3. Press the down arrow two (2) times.
4. Select DISPOSE.
5. "DISPOSE NOW? is displayed. *
6. Press the √ (check) button to dispose of oil in vat.
7. "REMOVE FILTER PAN" is displayed. Remove the filter pan.
8. "IS FILTER PAN EMPTY?" is displayed. Press the √ (check) button if the pan is empty and reinsert pan.
9. "START DISPOSE" is displayed with blue button. Press the blue button.
10. "DRAINING" is displayed.
11. "VAT EMPTY? is displayed.
12. Once the vat is empty, press the √ (check) button.
13. "CLEAN VAT COMPLETE? is displayed.
14. Press the √ (check) button.
15. "OPEN DISPOSE VALVE" is displayed.
16. Open dispose valve.
17. "DISPOSING" is displayed for four minutes.
18. "REMOVE PAN" is displayed.
19. Remove filter pan.
20. "IS PAN EMPTY? is displayed.

21. Press the √ (check) button if the filter pan is empty. Select "NO" if oil remains in the filter pan.
22. "INSERT PAN" is displayed.
23. Insert the filter pan.
24. "CLOSE DISPOSE VALVE" is displayed.
25. Close dispose valve.
26. "FILL VAT FROM BULK?" is displayed.
27. Press "NO" if you wish to leave vat empty and exit.

1.20.4.3 Fill Vat from Bulk



1. The vat must be off.
2. Press the filtration menu button.
3. Select LEFT VAT or RIGHT VAT for split vats.
4. Press the down arrow.
5. Select FILL VAT FROM BULK.
6. "FILL VAT FROM BULK?" is displayed.
7. Press the √ (check) button.
8. "START FILLING? PRESS AND HOLD" is displayed.
9. Press and hold the button to fill the vat.
10. "RELEASE BUTTON WHEN FULL" is displayed.
11. Release the button when the vat is full.
12. "CONTINUE FILLING?" is displayed
13. Press the √ (check) button to continue filling or press "NO" to exit.

1.20.4.4 Fill Oil Reservoir from Bulk *

1. When TOP OFF OIL EMPTY is displayed, the oil reservoir (top-off container) is empty.
2. To refill reservoir, press and hold the orange reset button above the reservoir until the reservoir is full.
3. Release the button to stop filling.

1.20.5 Troubleshooting Oil Reservoir Filling

***NOTE: The reservoir may not fill if any of the following are in progress:**

If **FILTRATION REQUIRED – FILTER NOW? YES/NO**, or **SKIM, DEBRIS FROM VAT – PRESS CONFIRM WHEN COMPLETE** are displayed, the fill reservoir button is disabled until either a filter is complete or until NO is chosen.

The system also checks these conditions. The following must be met before an oil reservoir fill is allowed:

- Solenoid closed
- Orange fill button pressed longer than 3 sec.
- FILTRATION REQUIRED – FILTER NOW? YES/NO, or SKIM, DEBRIS FROM VAT – PRESS CONFIRM WHEN COMPLETE cannot be displayed
- System power cycle (all boards – Controllers, SIB, VIB and FIB) after changing setup from JIB to Bulk (use momentary reset). Ensure reset is pressed and held for at least **sixty (60) seconds**.
- No filtration or other filter menu selection can be in process.

Other factors that may not allow fill reservoir from bulk –

- Defective solenoid
- Defective orange reset switch
- Bulk oil pump issue
- Bulk oil relay stuck

If using two fryer systems that are both attached to the bulk oil system, they may not be able to fill both units at the same time if they have a bulk fresh oil unit with a single head. Some bulk oil fresh units have dual heads which can fill simultaneously.

1.21 VIB (Valve Interface Board) Service Procedures

The VIB (Valve Interface Board) controls the actuators that open and close the drain and return valves. The VIB boards are located inside a protective housing under each frypot (see Figure 39).



Figure 39

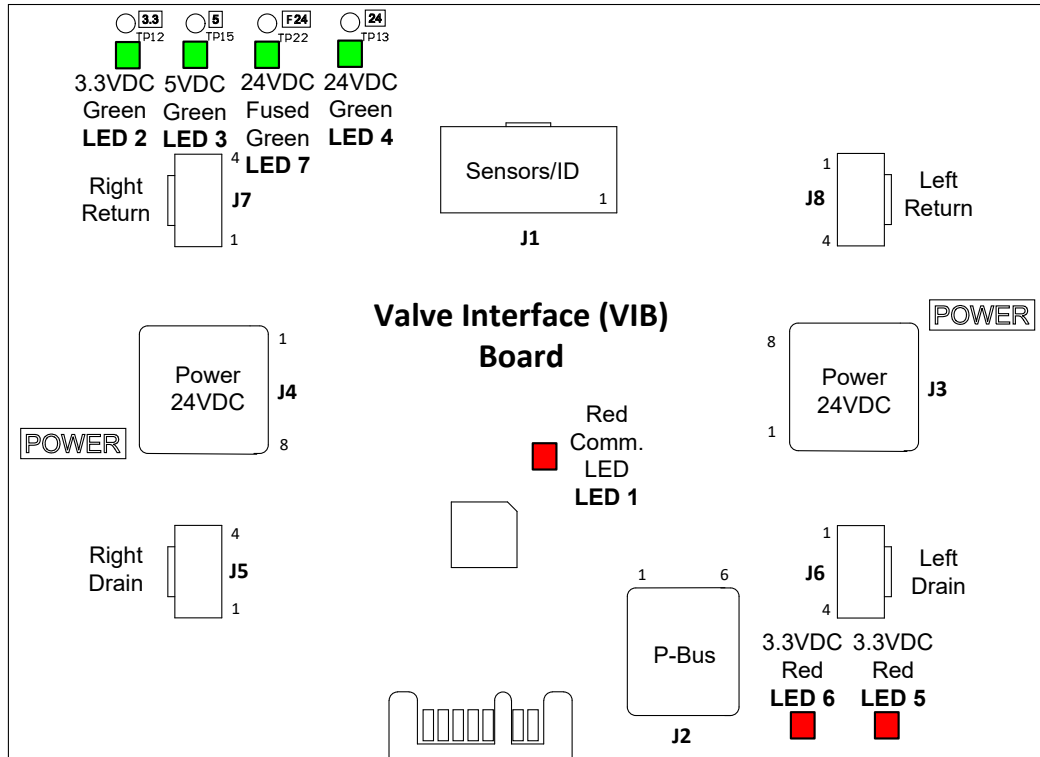

Figure 40

1.21.1 VIB (Valve Interface Board) Troubleshooting

NOTE: DO NOT CHECK WITH HARNESES UNPLUGGED AS SHORTING THE PINS MAY OCCUR WHICH WILL DAMAGE THE BOARD.

Problem	Probable Causes	Corrective Action
<p>Actuator doesn't function.</p>	<p>A. No power to the VIB board. B. Actuator is unplugged. C. VIB/FIB board failure. D. Actuator voltage is incorrect. E. Actuator is defective.</p>	<p>A. Check pins 4 and 5 of J2 at the FIB board. Should read 24VDC. Check voltage on pins 4 and 5 at the other end of harness and ensure 24VDC is present. Continue to check pins 4 and 5 for 24VDC on plugs J3 and J4 on the VIB boards.</p> <p>B. Ensure the actuator is plugged into the proper connection (J7 for FV or Right DV return, J8 for Left DV return and J5 for FV or Right DV drain and J6 for Left DV drain).</p> <p>C. Check the DC voltage with the actuator plugged in on the connector of the problem actuator while trying to manually open or close an actuator. <u>DO NOT CHECK WITH ACTUATOR UNPLUGGED AS SHORTING THE PINS MAY OCCUR WHICH WILL DAMAGE THE BOARD.</u> Pins 1 (Black) and 4 (White) should read +24VDC when the actuator is opening. Pins 2 (Red) and 4 (White) should measure -24VDC when the actuator is closing). If either voltage is missing, the VIB board or FIB board is likely bad. Test the actuator by plugging into another connector. If the actuator operates, replace the VIB board.</p> <p>D. Check the DC voltage with the actuator plugged in between pin 3 (blue wire) and pin 4 (white wire). <u>DO NOT CHECK WITH ACTUATOR UNPLUGGED AS SHORTING THE PINS MAY OCCUR WHICH WILL DAMAGE THE BOARD.</u> Closed = below 0.825VDC and above 4mv. Open = Below 2.475V and above 0.825VDC. The voltage is out of tolerance and will have failure status if values are above 2.475VDC or less than 4mv.</p> <p>E. If proper voltages are present at the connector and actuator doesn't operate reset power to the fryer. If it still doesn't operate, replace the actuator.</p>
<p>Actuator functions on wrong vat or wrong valve.</p>	<p>A. Actuator plugged into wrong connector.</p>	<p>A. Ensure the actuator is plugged into correct connection (J7 for FV or Right DV return, J8 for Left DV return and J5 for FV or Right DV drain and J6 for Left DV drain).</p>

1.21.2 VIB (Valve Interface Board) Actuator Board Pin Positions and Harnesses

NOTE: DO NOT CHECK WITH HARNESSES UNPLUGGED AS SHORTING THE PINS MAY OCCUR WHICH WILL DAMAGE THE BOARD.

Connector	From/To	Harness PN	Pin #	Function	Voltage	Wire Color	
J1	VIB (AIF) Probes, OIB Probes	1086013 Full VIB 1086014 Split VIB 8263287 VIB (AIF) Probe Only	1	Right VIB Probe Ground	Ohm	Yellow	
			2	Right VIB Probe		Red	
			3	Left VIB Probe Ground		Yellow	
			4	Left VIB Probe		Red	
			5	Right OIB Ground		Green	
			6	Right OIB Probe		White	
			7	Left OIB Ground		Green	
			8	Left OIB Probe		White	
			9	Right OIB Relay +		24VDC	Red
			10	Right OIB Relay -			Black
			11	Left OIB Relay +	24VDC	Red	
			12	Left OIB Relay -		Black	
			13	Ground			
			14	24VDC +	24VDC		
J2	P-Bus Power Communication from SIB (RJ11)	8075555	1	Ground			
			2	P-BUS power	+5VDC		
			3	Modbus RS485 B			
			4	Modbus RS485 A			
			5	Signal ground			
			6	P-BUS power	+12VDC		
J3	24VDC Power Input between VIB Boards (RJ45)	8075810	1	Ground			
			2	Ground			
			3	Ground			
			4	Ground			
			5	Power	+24VDC		
			6	Power	+24VDC		
			7	Power	+24VDC		
			8	Power	+24VDC		
J4	24VDC Power Output between VIB Boards (RJ45)	8075810	1	Ground			
			2	Ground			
			3	Ground			
			4	Ground			
			5	Power	+24VDC		
			6	Power	+24VDC		
			7	Power	+24VDC		
			8	Power	+24VDC		
J5	FV (Right) Drain		1	Drain + (Open)	+24VDC	Black	
			2	Drain - (Closed)	-24VDC	Red	
			3	Drain Position		Blue	
			4	Ground		White	
J6	DV (Left) Drain		1	Drain + (Open)	+24VDC	Black	
			2	Drain - (Closed)	-24VDC	Red	
			3	Drain Position		Blue	
			4	Ground		White	
J7	FV (Right) Return		1	Ret + (Open)	+24VDC	Black	
			2	Ret - (Closed)	-24VDC	Red	
			3	Ret Position		Blue	
			4	Ground		White	
J8	DV (Left) Return		1	Ret + (Open)	+24VDC	Black	
			2	Ret - (Closed)	-24VDC	Red	
			3	Ret Position		Blue	
			4	Ground		White	

1.21.3 Replacing a VIB (Valve Interface Board)

Disconnect the fryer from the electrical power supply. Locate the VIB (valve interface board) to be replaced under a frypot. Mark and unplug the harnesses. The VIB assembly is held in place with one screw (see Figure 41). Remove the screw and the assembly drops down (see Figure 42) and the tab slides out of the bracket attached to the frypot (see Figure 43). Reverse steps to reassemble, ensuring that the new VIB assembly slides into the slot in the bracket. Once complete, **CYCLE POWER TO ENTIRE FRYER SYSTEM**. See section 1.19.2 to reset control power. Check software version # and if necessary update the software. If a software update is necessary, follow the instructions to update the software in section 1.23.

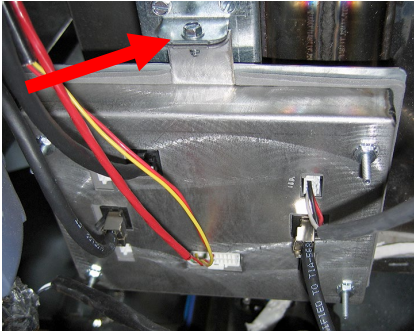

Figure 41

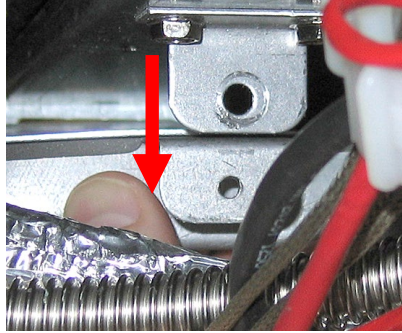

Figure 42

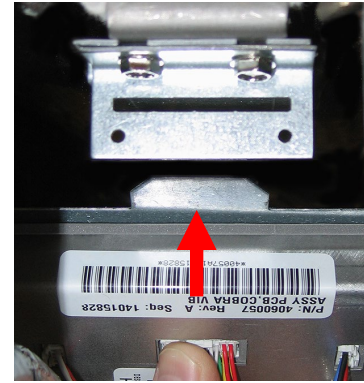

Figure 43

1.21.4 Replacing a Rotary Actuator

Disconnect the fryer from the electrical power supply. Locate the actuator to be replaced and mark and unplug the actuator. The actuators are held in place by two Allen screws. Loosen the Allen screws. It may be necessary to remove a gas line to the burner when removing a drain actuator. Remove the actuator from the valve stem. Align the actuator with the valve stem and attach the new actuator. Tighten the two Allen screws. Reconnect power and test the actuator.

NOTE: Rotary actuators have two different part numbers which are also color coded (blue and black), which are mirror images of each other that correspond to their mounting position.

1.21.5 Oil Level Sensor (OIB [Oil Is Back]) (optional)

The oil level sensor is a device that is used to prevent dry firing of the frypot (see Figure 44). The sensor looks similar to a high limit sensor. The sensor is energized when the controller is powered on with a soft on. The sensor heats up and detects the oil around it. During filtration when the oil is drained, it senses the difference between the oil and air. It is controlled with a board located next to the interface board (see Figure 45) and a separate egg-shaped plastic device (see Figure 46) that contains additional electronics.

Use care when working with the sensor as temperatures may reach as high as 500°F (260°C).

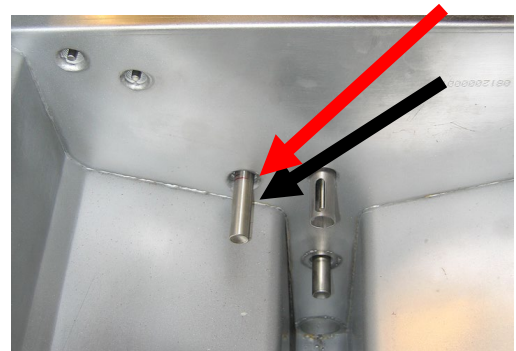
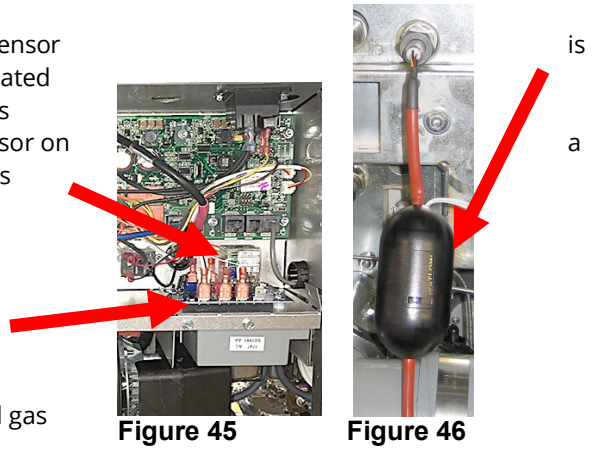

Figure 44

If oil is surrounding the heater, the oil will prevent the heater from ever reaching its setpoint as the oil acts as a heat sink. Once oil is removed during filtration the heater reaches setpoint and cycles a thermostat every four seconds. Since the cycle is only four seconds, the seven second delay is not made, and the gas valve won't open.

The 100-120VAC (220-240VAC on Intl. units) in the control box is supplied from the transformer box. The power to the oil level sensor controlled by the clear oil level sensor (OIB) power relay. It is located behind the time delay relay board in the control box. The relay is controlled by the VIB board on J1 pins 9 and 10 for the right sensor on dual vat or a full vat. The relay for the left sensor on a dual vat is controlled by the VIB board on J1 pins 11 and 12.



1.21.5.1 Oil Level Sensor Troubleshooting

Typical Sensor Related Failures

-E65 in the error log.

If the controller continues to display E65 and does not heat, and gas supply, gas valve, etc. have been checked and no heat lamp illuminates because no call for heat is initiated, then follow these steps:

- Check (see diagram below)

- If the oil level sensor is cycling 4 sec. on/off and oil is surrounding the sensor, the sensor may have a carbon accumulation that is self-insulating the sensor. Use a no scratch pad to remove the carbon accumulation. A common message is "E65 CLEAN OIB SENSOR" or "E65 OIL LEVEL NOT DETECTED". If the sensor is clean and these messages are displayed, the time delay relay board relay may be the cause. Replace the time delay relay board.
- Power to oil sensor (from oil level sensor) relay in control box. Check for 100-120VAC (220-240VAC on Intl. units).
- Power to heater/relay coil on relay board. Check voltage to the coil between pins 8 and 1 to ensure that 100-120VAC (220-240VAC on Intl. units) is present with oil in the vat. If the vat is empty, the power will cycle 4 seconds on, 4 seconds off.
- Check voltage between pin 3 and 2 on the relay board. It should read 3.3VDC for air and 0VDC for oil. A common message for a shorted harness or issue is "IS DRAIN CLEAR?" with oil in the filter pan. Low voltage on these pins may cause E65 errors due to time delay relay board issues. Replace the time delay relay board.
- Check VIB harness on J1. Interrupted communication will prevent the fryer from heating.

1.21.5.2 Oil Level Sensor Diagram

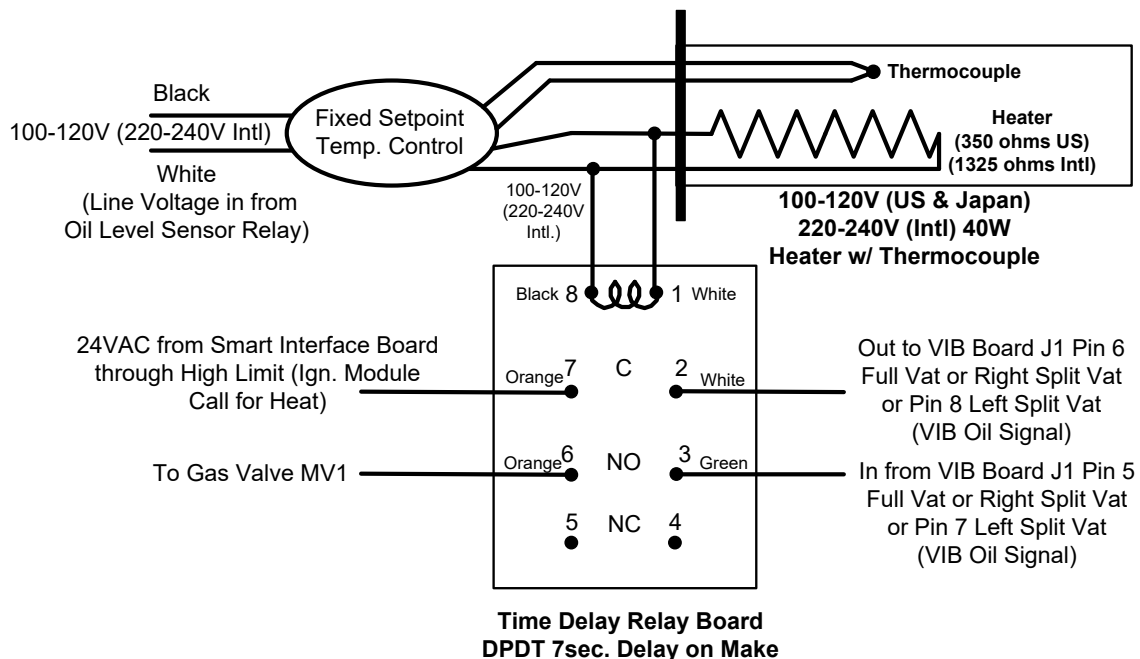

Figure 47

1.22 FQ4000 Controller Service Procedures

1.22.1 FQ4000 Controller Troubleshooting

Problem	Probable Causes	Corrective Action
No Display on Controller.	<ul style="list-style-type: none"> A. No power to the fryer. B. Controller has failed. C. Damaged controller wiring harness. D. Power supply component or SIB (Smart Interface Board) has failed. E. Shorted or melted harness from VIB to SIB. 	<ul style="list-style-type: none"> A. Verify the power cord is plugged in and that circuit breaker is not tripped. B. Swap the controller with a controller known to be good. If controller functions, replace the controller. C. Swap with a harness known to be good. If controller functions, replace the harness. D. If any component in the power supply system (including the transformer and SIB Smart Interface Board) fail, power will not be supplied to the controller and it will not function. E. Check the harness from J2 on the VIB board to J10 on the SIB board. Inspect for heat damage and routing of harness close to the frypot. Inspection of the green LED's (LED 2, LED 4 and LED 6) on the SIB board should be brightly illuminated. If the green LED's are either blinking or dim or the harness is damaged, replace the harness (8075555).
Controller locks up.	Controller error.	Remove and restore power to the fryer (controller).
FQ4000 displays E45 RECOVERY FAULT.	Recovery time exceeded maximum time limit for two or more cycles.	Silence the alarm by pressing the check button. Check that fryer is heating properly. Maximum recovery for gas is 3:15. See Section 1.15.4 for an explanation of recovery time and section 1.15.2 Improper Burner Function. Reset the error code by going to: HOME -> SERVICE -> SERVICE ->3000-> TECH MODE -> RESETS -> RECOVERY FAULT CALL SERVICE -> YES.
FQ4000 displays E61 MISCONFIGURED ENERGY TYPE	Wrong energy type selected in service settings.	Press home button. Press Settings button. Press Service button again. Enter 3000. Press Energy Type and select correct energy type.
FQ4000 displays UNABLE TO READ USB DRIVE	Defective USB drive	Replace USB drive with USB drive.
FQ4000 displays FILE NOT FOUND	Missing files on USB drive	Ensure correct files are on USB drive.
FQ4000 displays SOFTWARE UPDATE CANCELLED - RESTART THE SYSTEM	<ul style="list-style-type: none"> A. USB drive removed during software update. B. Power loss during a software update. 	<ul style="list-style-type: none"> A. Restart the system and reload the software ensuring that the USB drive is not removed until prompted to do so. B. Reload the software from USB drive.
QUICK FILTER or CLEAN AND FILTER won't start.	Temperature too low.	Ensure fryer is at 310F (154C) before starting QUICK FILTER or CLEAN AND FILTER.
FQ4000 displays SERVICE REQUIRED with the type of error.	An error has occurred.	Press YES to silence alarm. The error is displayed three times. See list of issues in section 1.4. Fix issue. The controller displays SYSTEM ERROR FIXED? YES/NO. Press YES. Controller displays ENTER CODE. Enter 1111 to clear error code. Pressing NO will allow the fryer to cook but error will be redisplayed every 15 minutes.
FQ4000 display is in wrong temperature scale (Fahrenheit or Celsius).	Incorrect display option programmed.	Press home button. Press Service button. Press Service button again. Enter 3000. Press Tech Modes. Press Toggle to Select. Press F° to C° to toggle temperature scale. Press YES to confirm. Press check to complete. Press home to exit.
FQ4000 displays VAT ID CONNECTOR NOT CONNECTED	Vat ID locator connector unplugged from UI or grounded position in control box.	Ensure that the vat locator connector is properly connected to UI harness and ensure that ground on harness is properly grounded to control box.
FQ4000 displays NO MENU GROUP AVAILABLE FOR SELECTION	All menu groups have been deleted. NOTE: ALL RECIPES is not a group that can be used to cook recipes.	Create a new MENU group. Once a new menu is created, add recipes to the group (see section 4.11 of the IO manual).

Problem	Probable Causes	Corrective Action
FQ4000 displays CHANGE FILTER PAD.	Filter error has occurred, filter pad clogged, 24-hour filter pad change prompt has occurred or change filter pad was ignored on a prior prompt.	Change the filter pad and ensure the filter pan has been removed from the fryer for a minimum of 30 seconds. Do NOT ignore CHANGE FILTER PAD prompts.
FQ4000 displays E16 HIGH LIMIT 1 EXCEEDED.	Frypot temperature is more than 410°F (210°C) or, in CE countries, 395°F (202°C).	This is an indication of a malfunction in the temperature control circuitry, including a failure of the high-limit thermostat during normal operation.
FQ4000 displays E17 HIGH LIMIT 2 EXCEEDED.	Frypot temperature is high enough to open the physical bi-metallic high limit switch or the switch has failed.	This is displayed when the oil temperature is above 425°F (218°C) and the high-limit thermostat has opened, halting the heating of the oil. Let the high limit cool to determine if the switch closes. Check high limit resistance.
FQ4000 displays E18 HIGH LIMIT PROBLEM – DISCONNECT POWER – CALL SERVICE.	Failed high-limit.	This is displayed to indicate the high-limit has failed.
FQ4000 displays HOT-HI 1.	Controller in high-limit test mode.	This is displayed only during a test of the high-limit circuit and indicates that the frypot temperature is more than 410°F (210°C) or, in CE countries, 395°F (202°C).
FQ4000 displays HELP HI-2.	Controller in high-limit test mode.	This is displayed only during a test of the high-limit circuit and indicates that the high-limit has opened properly.
FQ4000 displays HIGH LIMIT FAILURE DISCONNECT POWER.	Controller in high-limit test mode. Failed high-limit.	This is displayed during a test of the high limit to indicate the high-limit has failed.
FQ4000 displays INSERT PAN.	A. Filter pan is not fully inserted into fryer. B. Missing filter pan magnet. C. Defective filter pan switch.	A. Pull filter pan out and fully reinsert into fryer. B. Ensure the filter pan magnet is in place and if missing replace. C. If the filter pan magnet is fully against the switch and controller continues to display INSERT PAN , switch is possibly defective.
FQ4000 displays MELT CYCLE IN PROGRESS.	Frypot temperature is below 180°F (82°C).	This display is normal when the fryer is first turned on while in the melt cycle mode. To bypass the melt cycle press BYPASS MELT CYCLE button next to the PREHEAT . The controller displays PREHEAT while heating to setpoint. If the display continues, the fryer is not heating.
FQ4000 displays PREHEAT.	Frypot temperature is above 180°F (82°C).	This display is normal when the fryer is above 180°F (82°C) but below setpoint. If the display continues, the fryer is not heating. Clean the OIB temperature sensor.
FQ4000 displays E13 TEMPERATURE PROBE FAILURE CALL SERVICE.	A. Problem with the temperature measuring circuitry including the probe. B. Bad Connection	A. This indicates a problem within the temperature measuring circuitry. Check resistance of probe, if faulty replace probe. B. Ensure temperature probe is connected properly to SIB board. Ensure that the connector is terminated properly.
FQ4000 displays E19 HEATING FAILURE	A. Heat or latch circuit failed. B. SIB failure	A. Check the heat or latch circuit. B. Replace the SIB board.
FQ4000 displays E65 CLEAN OIB SENSOR or E65 OIL LEVEL NOT DETECTED	Dirty OIB sensor.	Clean the OIB sensor. If the sensor is clean, the time delay relay board may be the issue.
FQ4000 displays E28 HEATING FAILURE.	Failed or closed gas valve, dirty blower, low micro amps, defective sensor wire, defective igniter/ignition cable, defective ignition module, improper gas pressure, failed SIB, or open high-limit thermostat.	Turn off the vat with the issue and back on again to see if issue corrects itself. The error is displayed if the fryer loses its ability to heat oil. This error comes from the alarm signal on the ignition module. It sometimes is seen when air is in the gas line.
FQ4000 displays software version for only FQ4000, SIB, VIB or FIB but not all boards.	Loose or damaged harness	Check that all harnesses between FQ4000's, SIB, VIB and FIB are secure. Check for loose or broken pins/wires. If the problem persists, swap out controller from one bank to another and cycle power on the fryer.

Problem	Probable Causes	Corrective Action
<p>FQ4000 displays IS VAT FULL? YES NO.</p>	<p>A. Normal operation during most at the beginning or end of most filtration functions.</p> <p>B. If the display appears many times during a filter it could be an indication of slow oil return</p> <p>C. A filter error has occurred due to dirty or clogged filter pad or paper, clogged pre-filter, clogged filter pump, filter pump thermal overload, improperly installed filter pan components, worn or missing O-rings, cold oil or an actuator problem.</p>	<p>A. Ensure the vat is full of oil and press the √ button.</p> <p>B. See section 1.18.2 troubleshooting –Filter Pump runs, but oil return is very slow.</p> <p>C. Ensure the filter pad/paper is clean, pre-filter is clean; O-rings are present and not worn; filter pump overload is not tripped.</p>

1.22.1.1 FQ4000 Controller Functional Troubleshooting

There are four (4) LED status lights on the rear of the controller which provide a quick method to verify power and touch screen functionality on the FQ4000 controller.

To verify that the FQ4000 has power and the touch screen is functional, remove the 2 screws attaching the controller to the bezel. Lower the controller to view the LED's on the rear of the controller board. Verify that the three (3) green LED's are illuminated which indicate that 3V, 5V and 12V power is present on the controller. These should be illuminated at all times. Pressing anywhere on the front of the touch screen will illuminate the red LED STATUS (see photo below). The red LED will also illuminate during power up momentarily.

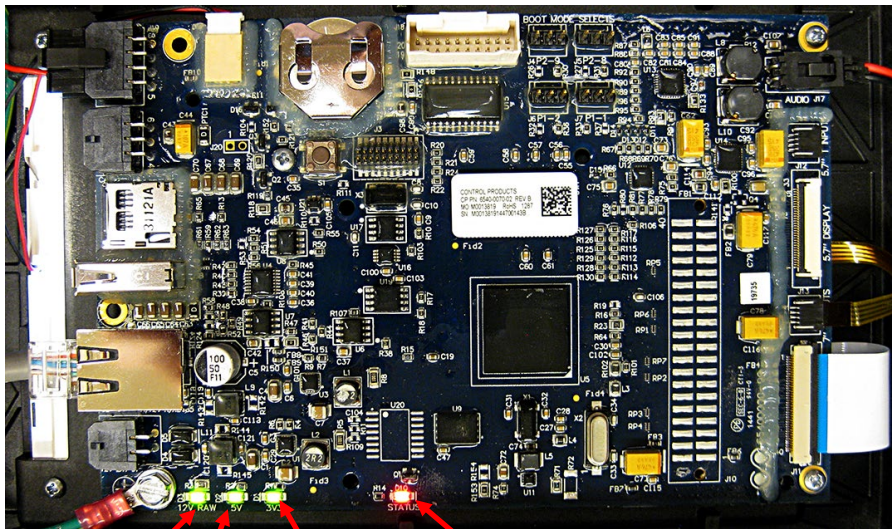

12V from SIB
 5V from SIB
 3V from power supply on UIB

When the touch screen is pressed the STATUS LED illuminates RED.

1.23 Loading and Updating Software Procedures

Updating the software takes approximately 30 minutes. The software only needs to be loaded in the USB port in the far-left fryer cabinet and it will update **ALL** the controllers and boards in the system. To update the software, follow these steps carefully:

- **The software update may lose the location of product icon on the front screen after the update. Take either a picture/notation of the product locations on the 12 lanes for each vat to ensure they can be loaded back at the end of the update.**
- **Check with the manager about any LTO's (Limited Time Offer) products that may have been programmed into the controllers. If so, capture the product details such as product name, cook time, etc. to program in later.**

The following reset MUST be performed to clear items before updating.

1. Power cycle the fryer control power using the reset switch. In most FQG30-T models, this is located under the USB slot (see Figure 3). In some older FQG30-T models, the momentary rocker switch (see Figure 4) is located under the far-left control box (see Figure 5). If the switch is not accessible, unplug the fryer or turn off the breaker to the fryer. **ENSURE THE SWITCH IS PRESSED AND HELD FOR 30 SECONDS.**
2. With the vats **OFF**, remove the jug of oil from under the fryer and manually top off the vats to the upper oil level line prior to starting the update.
3. Pull the filter pan slightly out of the fryer until "P" is visible in the top right corner of the displays.
4. On the **FAR-LEFT** controller press the HOME button.
5. Press the SERVICE button.
6. Press the SERVICE button again.
7. Enter 3000.
8. Press the check button.
9. Press the down arrow button.
10. Press the FIB-RESET 2 button.
11. Press YES to confirm.
12. RESET COMPLETED SUCCESSFULLY is displayed once the reset is complete. If a CAN COMMUNICATION FAILED error occurs see Troubleshooting in section 1.23.1.3.
13. Press the check button.
14. Press the home button.

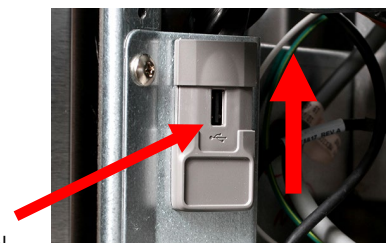

Figure 1

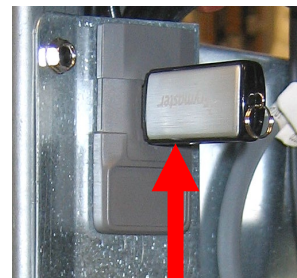

Figure 2

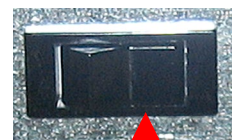

Figure 4



Figure 3

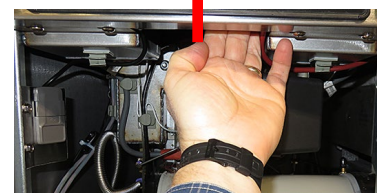

Figure 5

To update the software, follow these steps carefully:

1. Switch **ALL** controllers to **OFF**. Press the home button then the information (?) button; press the down arrow; press the SW version button. The controller displays INTIALIZING. Write down the current (UIB, SIB, VIB and FIB) software versions.
2. On the **FAR-LEFT** controller press the HOME button.
3. Press the SERVICE button.
4. Press the SERVICE button again.
5. Enter 3000 for and press the checkmark button.
6. Press the TECH MODES button.
7. Press the down arrow.
8. Press the SOFTWARE UPGRADE button.
9. Controller displays INSERT USB.
10. Open the far-left cabinet door and slide the USB cover up (see Figure 1).
11. Insert the USB flash drive (see Figure 2).
12. The controller displays IS USB INSERTED? YES NO
13. Press the YES button after the USB flash drive is inserted.
14. Controller displays READING FILE FROM USB. PLEASE DO NOT REMOVE USB WHILE READING.
15. Controller displays READING COMPLETED, PLEASE REMOVE USB.
16. Remove the USB flash drive and lower cover over the USB slot.
17. Press the YES button after the USB flash drive is removed.
18. Controller displays CONFIRM CONTROLLERS AVAILABLE FOR UPGRADE UIB, SIB, VIB AND FIB.
19. Press the YES button to continue.
20. Controller displays UIB/SIB/VIB/FIB – DATA TRANSFER IN PROGRESS, WILL COMPLETE IN X MINUTES for each board.
21. Controller displays UIB/SIB/VIB/FIB – UPGRADE IN PROGRESS, WILL COMPLETE IN X MINUTES for each board.
22. When the software update is complete, the controller will display UPGRADE COMPLETE? YES on **the far LEFT controller.**
23. Press the YES button.

24. The controller displays UPGRADE COMPLETED, POWER CYCLE THE SYSTEM.
25. Cycle the fryer control power using the reset switch. In most FQG30-T models, this is located under the USB slot (see Figure 3). In some older FQG30-T models, the momentary rocker switch (see Figure 4) is located under the far-left control box (see Figure 5). If the switch is not accessible, unplug the fryer or turn off the breaker to the fryer. **ENSURE THE SWITCH IS PRESSED AND HELD FOR 30 SECONDS.** Failure to press and hold the reset switch long enough, may cause an incomplete software update.
26. While the fryer is rebooting some controllers may take a while to completely reboot as the software is loading.
27. Once all controllers have returned to the (OFF) power standby switch state. **DO NOT POWER ON! Powering on the fryer, prior to loading the MENU's, may disable the fryer!**
28. **VERIFY** software update by pressing the home button; press the information (?) button; press the down arrow; press the Software Version button. The controller displays INITIALIZING. Ensure that the software versions have updated to the correct versions.
29. If software versions match on **ALL** screens, press the home button and proceed to Step 31.
30. If software versions **DO NOT** match, press the home button and return to Step 1.
31. Press the home button. - Press the CREW MODE button.
32. The software update is complete.
33. The menu file(s) **MUST** be updated with this software update. Follow the steps in the next section(s) to update the menu file.

1.23.1 Updating Menu Files

Follow the steps in section 1.23.1.1 to update menus for Taco Bell. For General Market (Non-Taco Bell) use the instructions in section 1.23.1.2 to update the menus.

1.23.1.1 Taco Bell Menu Update Instructions

NOTE: This will overwrite any current product menu items and their settings. This may require re-entering any limited time offering products cook times, temperatures, etc. and reassigning products to their locations on the touch screen controller.

1. Switch all controllers to **OFF**.
2. On the **FAR-LEFT** controller press the HOME button.
3. Press the SERVICE button.
4. Press the MANAGER button.
5. Enter 1656.
6. Press the check button.
7. Press the USB – MENU OPERATION button.
8. Press the COPY MENU FROM USB TO FRYER button.
9. The controller displays INSERT USB.
10. Open the far-left cabinet door and slide the USB cover up (see Figure 1).
11. Insert the USB flash drive (see Figure 2).
12. The controller displays IS USB INSERTED? YES NO
13. Press the YES button after the USB flash drive is inserted.
14. Controller displays READING FILE FROM USB. PLEASE DO NOT REMOVE USB WHILE READING.
15. Controller displays UI – UI DATA TRANSFER IN PROGRESS changing to MENU UPGRADE IN PROCESS.
16. Controller displays UPGRADE COMPLETE?
17. Press YES
18. Controller displays MENU UPGRADE COMPLETED, REMOVE THE USB AND RESTART THE ENTIRE BATTERY.
19. Remove the USB flash drive and lower cover over the USB slot.
20. Press the YES button after the USB flash drive is removed.
21. Cycle the fryer control power using the reset switch. In most FQG30-T models, this is located under the USB slot (see Figure 3). In some older FQG30-T models, the momentary rocker switch (see Figure 4) is located under the far-left control box (see Figure 5). If the switch is not accessible, unplug the fryer or turn off the breaker to the fryer. **ENSURE THE SWITCH IS PRESSED AND HELD FOR 30 SECONDS.**
22. Push the filter pan back into the fryer until a “P” in **NOT** visible on the top right corner of the display.
23. Products may need reassigned to their locations and any limited time offer (LTO's) products may need to be reprogrammed into each controller, as they may have been overwritten during the update.

1.23.1.2 General Market Menu (Non-Taco Bell) Update Instructions

NOTE: This will overwrite any current product menu items and their settings. This may require re-entering any limited time offering products cook times, temperatures, etc. and reassigning products to their locations on the touch screen controller.

1. Switch all controllers to **OFF**.
2. On the **FAR-LEFT** controller press the HOME button.
3. Press the SERVICE button.
4. Press the MANAGER button.
5. Enter 1656.
6. Press the check button.
7. Press the USB – MENU OPERATION button.
8. Press the COPY MENU FROM USB TO FRYER button.
9. The controller displays INSERT USB.
10. Open the far-left cabinet door and slide the USB cover up (see Figure 1).
11. Insert the USB flash drive (see Figure 2).
12. The controller displays IS USB INSERTED? YES NO
13. Press the YES button after the USB flash drive is inserted.
14. Controller displays READING FILE FROM USB. PLEASE DO NOT REMOVE USB WHILE READING.
15. Controller displays menu file(s) on the USB drive with .cbr suffix(es).
16. Press the desired menu file to load.
17. Controller displays SELECT VATS FOR MENU UPGRADE.
18. Press each vat to load the desired menu. If file is to load to ALL vats press each number (Example: In a 3-vat system, press 1, 2 and 3).
19. Press the check button.
20. Controller displays UI – UI DATA TRANSFER IN PROGRESS changing to MENU UPGRADE IN PROCESS.
21. Controller displays UPGRADE COMPLETE?
22. Press YES on each controller.
23. Controller displays MENU UPGRADE COMPLETED, REMOVE THE USB AND RESTART THE ENTIRE BATTERY.
24. Remove the USB flash drive and lower cover over the USB slot.
25. Cycle the fryer control power using the reset switch. In most FQG30-T models, this is located under the USB slot (see Figure 3). In some older FQG30-T models, the momentary rocker switch (see Figure 4) is located under the far-left control box (see Figure 5). If the switch is not accessible, unplug the fryer or turn off the breaker to the fryer. **ENSURE THE SWITCH IS PRESSED AND HELD FOR 30 SECONDS.**
26. Push the filter pan back into the fryer until a “P” in **NOT** visible on the top right corner of the display.
27. Products may need reassigning to their locations and any limited time offer (LTO’s) products may need to be reprogrammed into each controller, as they may have been overwritten during the update.

1.23.1.3 Software/Menu Update Troubleshooting

CAN COMMUNICATION FAILED or CAN communication error during an update

1. Power cycle fryer ensuring that the reset switch is pressed and held for **60 seconds** or greater or power is removed for **60 seconds** or greater.
2. Update the software or menus again.
3. Check software versions or menus. If they still do not update repeat step #1 and recheck.

Software or menus do not update

1. Power cycle fryer ensuring that the reset switch is pressed and held for **60 seconds** or greater or power is removed for **60 seconds** or greater.
2. Recheck software versions or menus. If they still do not update repeat step #1 and recheck.

Product Icons/Photos missing

1. Update the menu files again.
2. Power cycle fryer ensuring that the reset switch is pressed and held for **60 seconds** or greater or power is removed for **60 seconds** or greater.
3. Recheck software versions or menus. If they still do not update repeat step #1 and recheck.



Display reboots automatically during an update

1. Power cycle fryer ensuring that the reset switch is pressed and held for **60 seconds** or greater or power is removed for **60 seconds** or greater.
2. Update the software or menu again.
3. Check software versions or menus. If they still do not update repeat step #1 and recheck.

Controller keeps rebooting after an update

1. Ensure **ALL** controllers display **OFF**.
2. Update the menu files again.
3. Power cycle fryer ensuring that the reset switch is pressed and held for **60 seconds** or greater or power is removed for **60 seconds** or greater.
4. Check menus. If they still do not update repeat step #1 and recheck.

Change Filter message after an FIB2 Reset

1. This is normal after an FIB2 reset.
2. Pull the filter pan slightly out of the cabinet until a "P" is visible on the top right corner of the display for **60 seconds** or greater until the message clears.
3. Push the filter pan back into the fryer.

Controller displays SPIFI FILE ERROR and SD CARD FILE ERROR

1. Flash drive not removed when prompted during software update. Remove the USB, power cycle the fryer, ensuring the power is removed for **60 seconds** or greater.

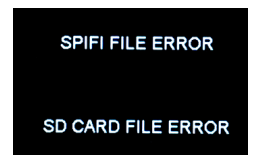

Controller displays NO SPIFI CRC AVAILABLE, SD CARD FILE ERROR, USB FILE ERROR

1. Power cycle the fryer, ensuring the power is removed for **60 seconds** or greater.
2. If the controller doesn't recover, the memory is corrupted. In some instances, the controller may be recovered, call 1-800-551-8633.
3. If the controller can't be recovered, replace the controller.

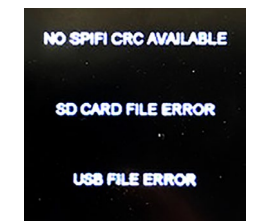

Software upgrade not available (grayed out).

1. Ensure the software upgrade is performed on the far-left controller.
2. Ensure all vats are soft powered OFF.
3. Controller vat ID locators are incorrect.
4. Check BOARD ID numbers in Software Version view of controller. Board ID = 1 on far-left controller, Board ID=2 on the next vat to the right, etc. If any are incorrect Board ID #'s check locator that is plugged in to the rear of the controller for proper pin position.

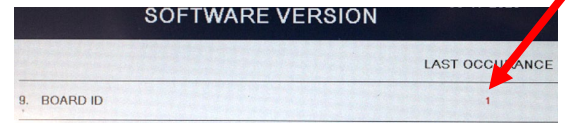
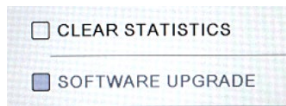

Controller display doesn't return after an update. Screen stays black for longer than 5 minutes.

1. Power cycle the fryer, ensuring the power is removed for **60 seconds** or greater.
2. If the controller doesn't recover, the memory is corrupted. Replace the controller.

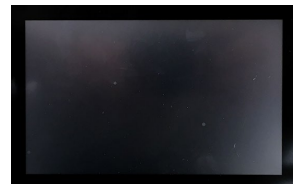

E81 – SAFE MODE FAILURE, TECHNICAL SUPPORT REQUIRED – Prompting for a password.

1. Fill the frypot with oil to top level line.
2. Press on text **ENTER PASSWORD** inside the box.
3. Enter **4 3 5 7** and press **[?]**.
4. Press the **[?]** button again.
5. The fryer is **OFF**.
6. Turn the fryer on and let it heat normally.

1.24 Wiring Diagrams

1.24.1 FQG30-T Series Simplified Wiring

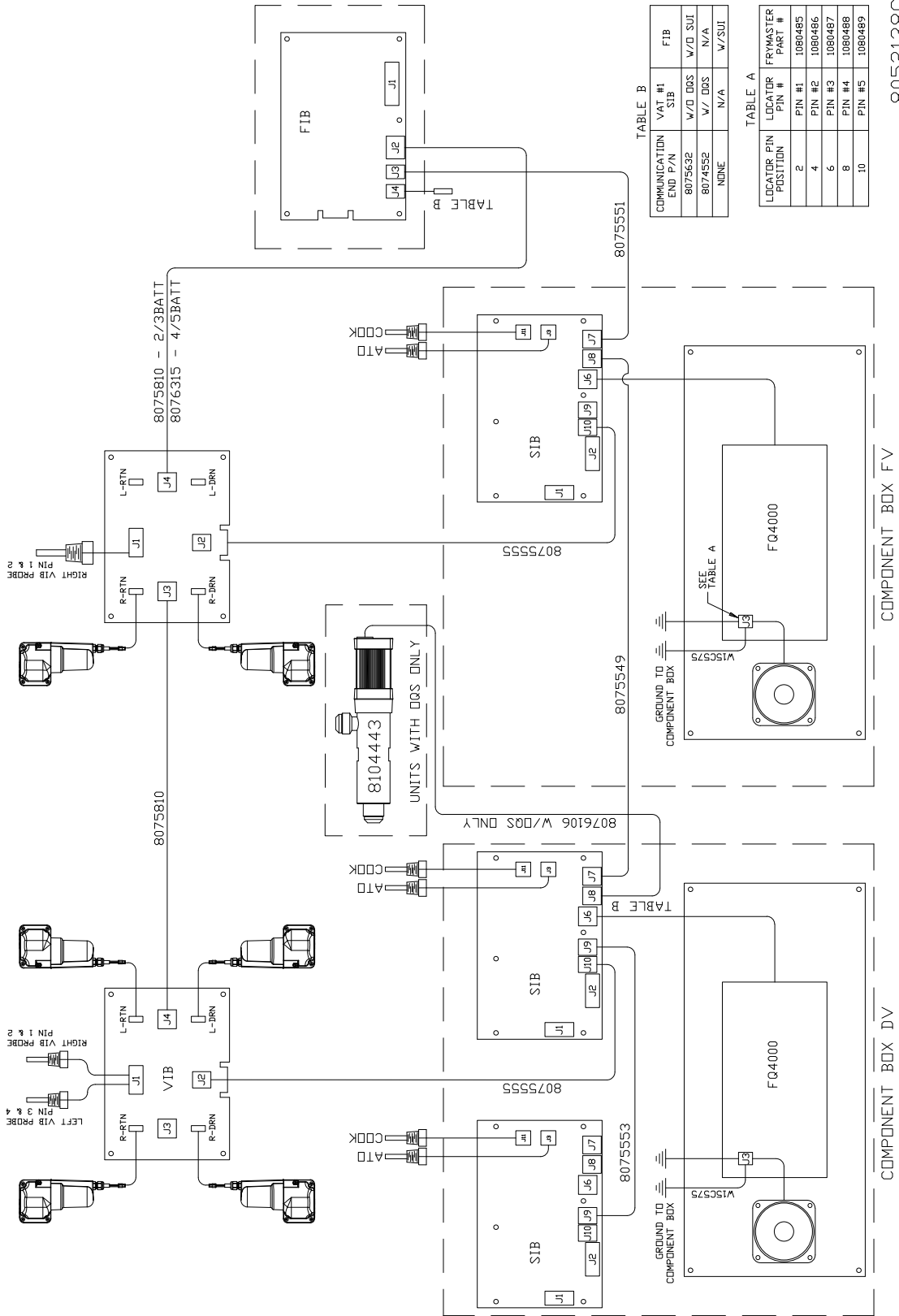

TABLE B

COMMUNICATION END P/N	VAT #1 SIB	FIB
8075632	W/D DQS	W/D SUI
8074552	W/ DQS	N/A
NONE	N/A	W/SUI

TABLE A

LOCATOR PIN POSITION	LOCATOR PIN #	FRYMASTER PART #
2	PIN #1	1080485
4	PIN #2	1080486
6	PIN #3	1080487
8	PIN #4	1080488
10	PIN #5	1080489

8052138C

1.24.5 Dual Vat Direct Spark Wiring Diagram Non-CE Domestic US with OIB Sensor (After 05/2019)

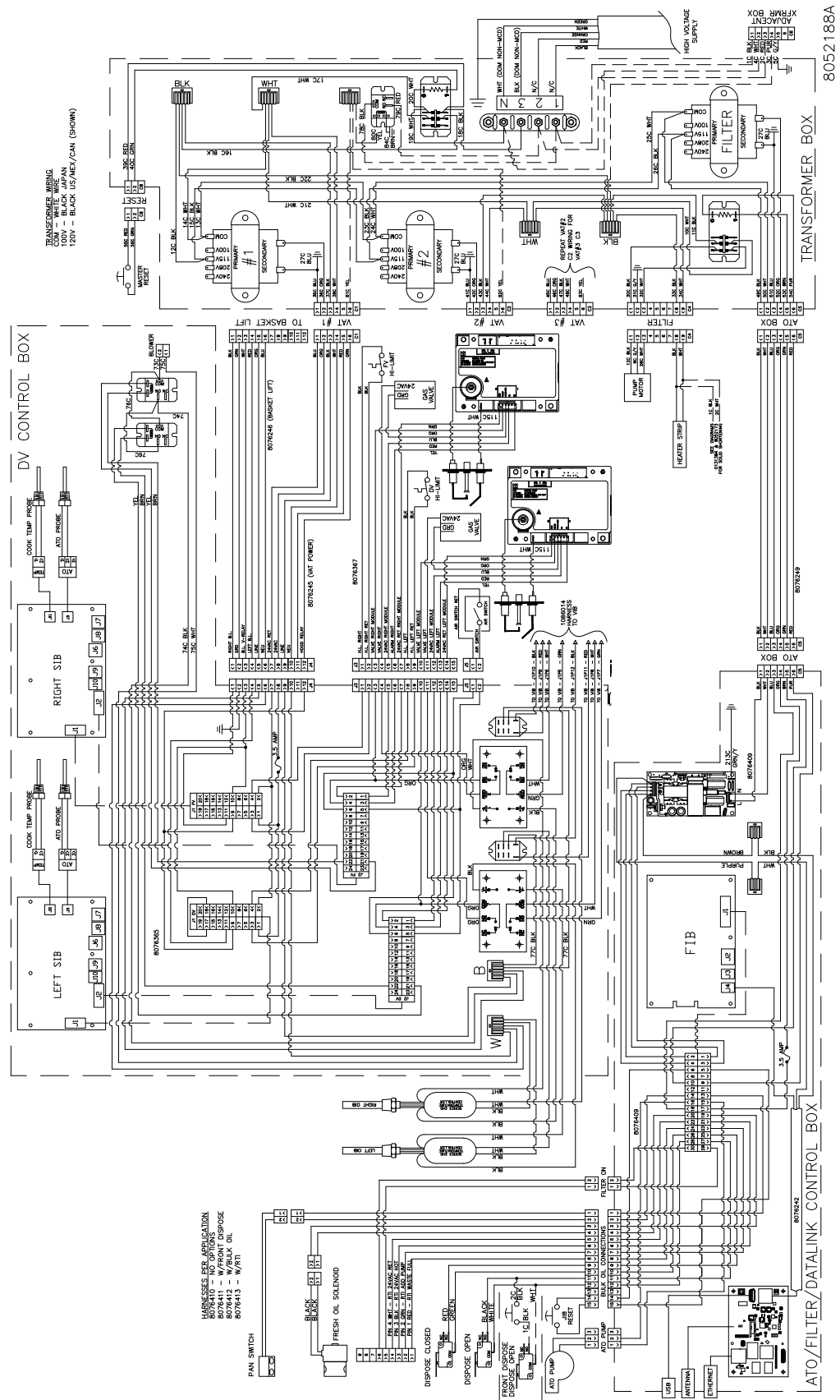

1.24.8 Dual Vat Direct Spark Wiring Diagram Non-CE Domestic US without OIB Sensor (Prior to 06/2019)

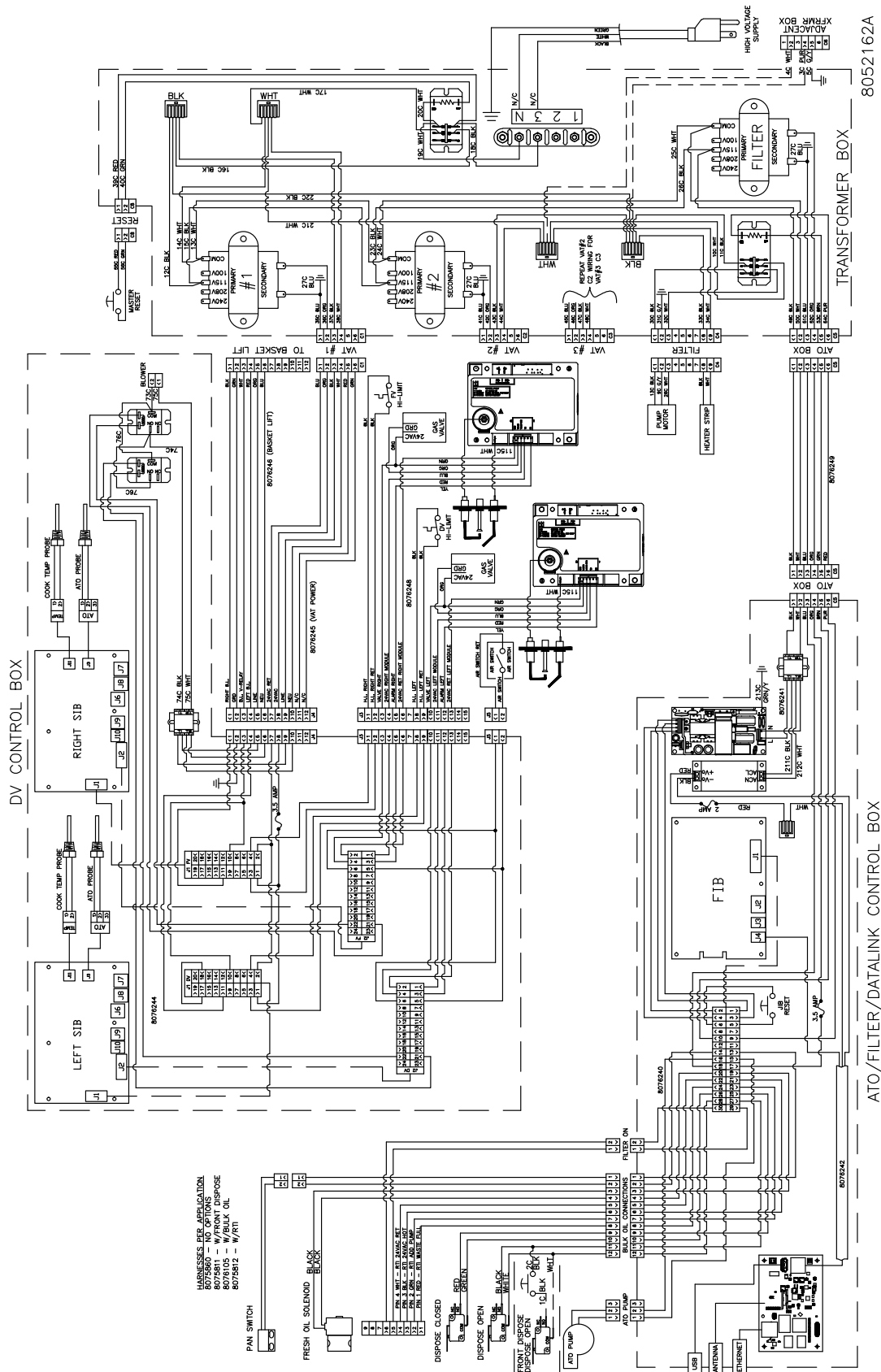

1.24.10 430-530 Transformer Wiring Diagram Non-CE

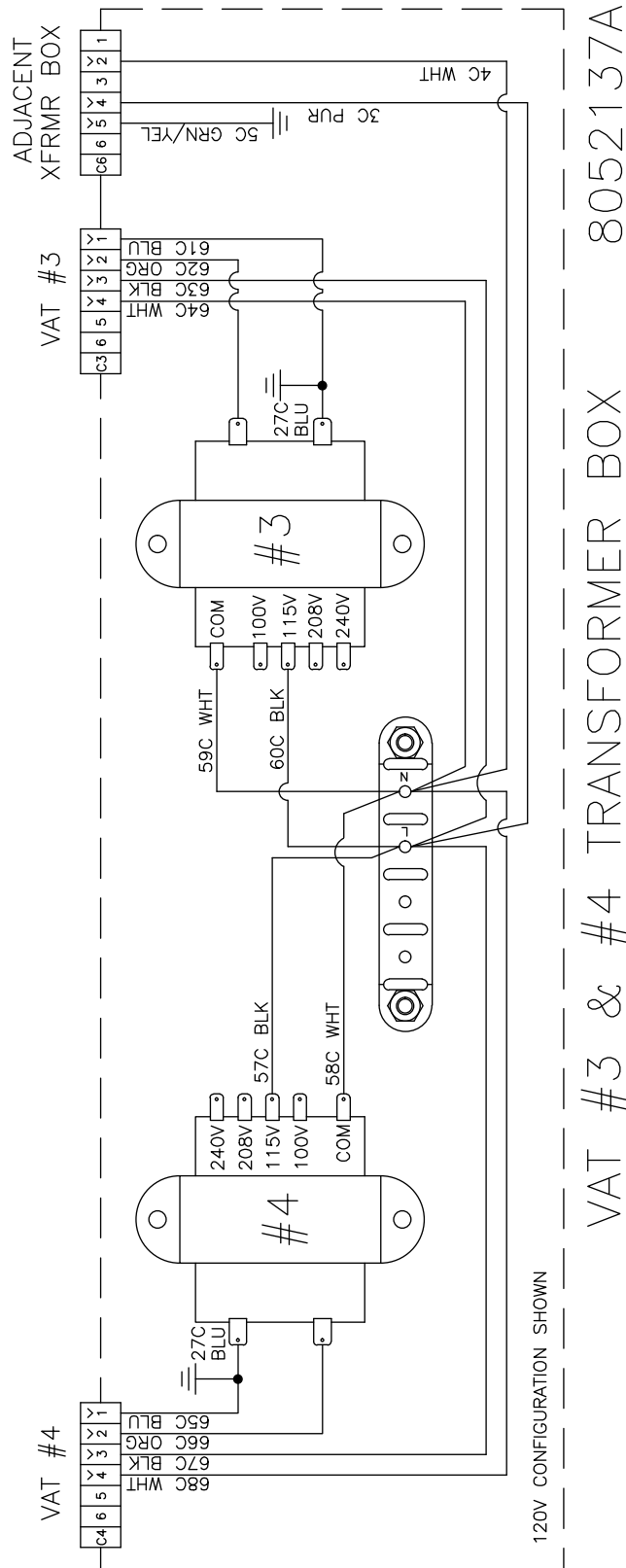

1.24.11 Full Vat Direct Spark Wiring Diagram CE with OIB Sensor (Prior to 06/2019)

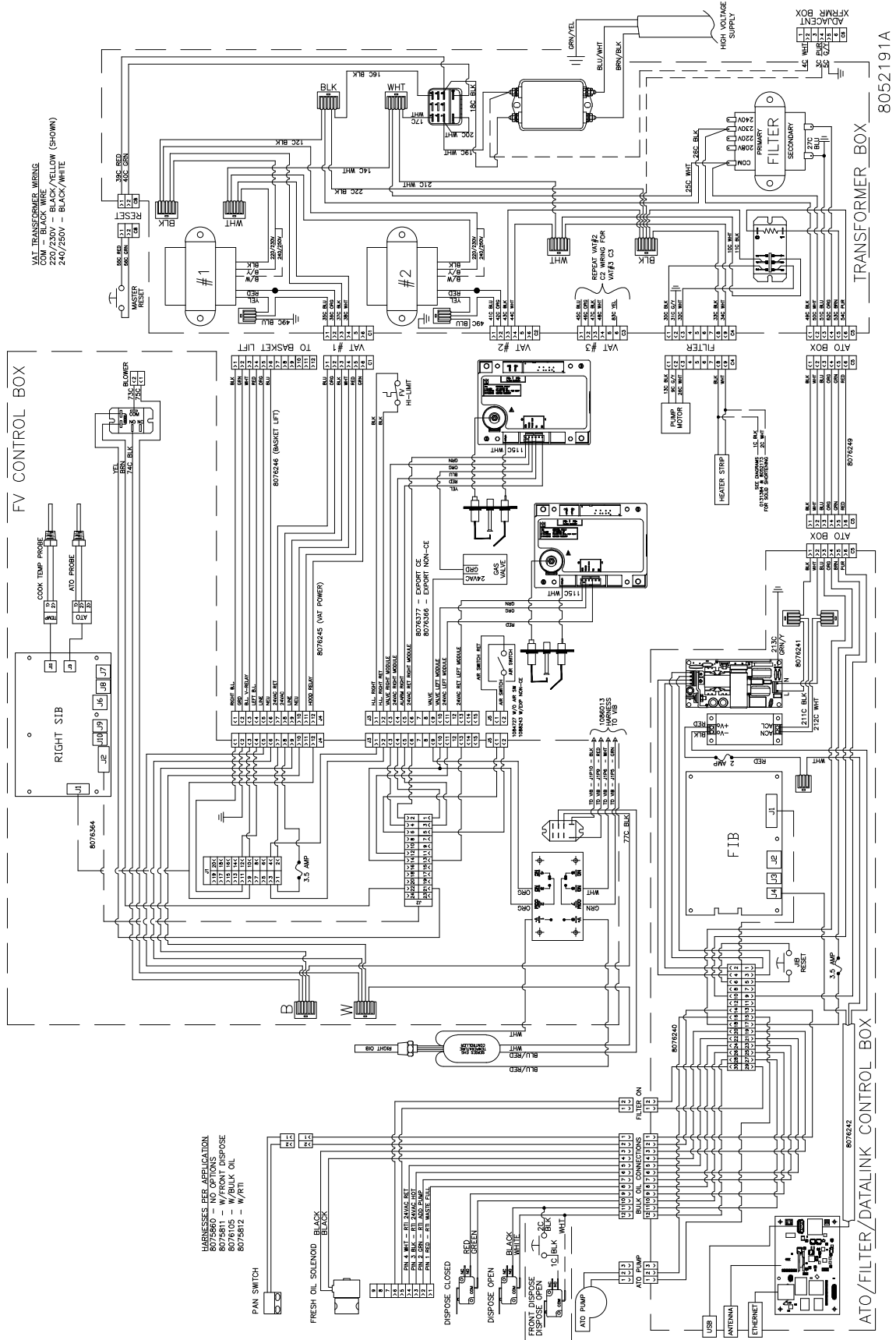

1.24.12 Full Vat Direct Spark Wiring Diagram CE with OIB Sensor (After 05/2019)

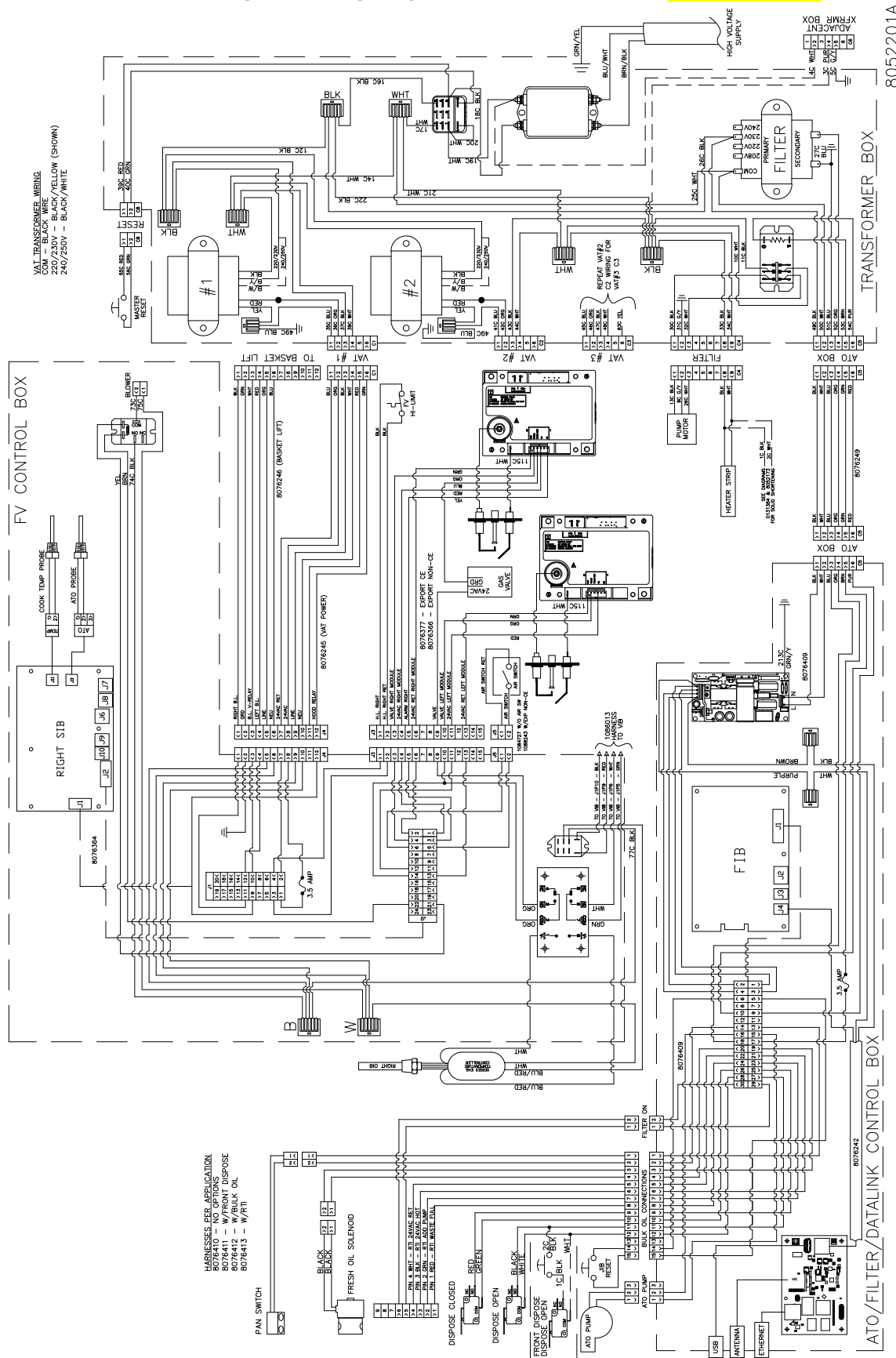

8052201A

1.24.14 Dual Vat Direct Spark Wiring Diagram CE with OIB Sensor (After 05/2019)

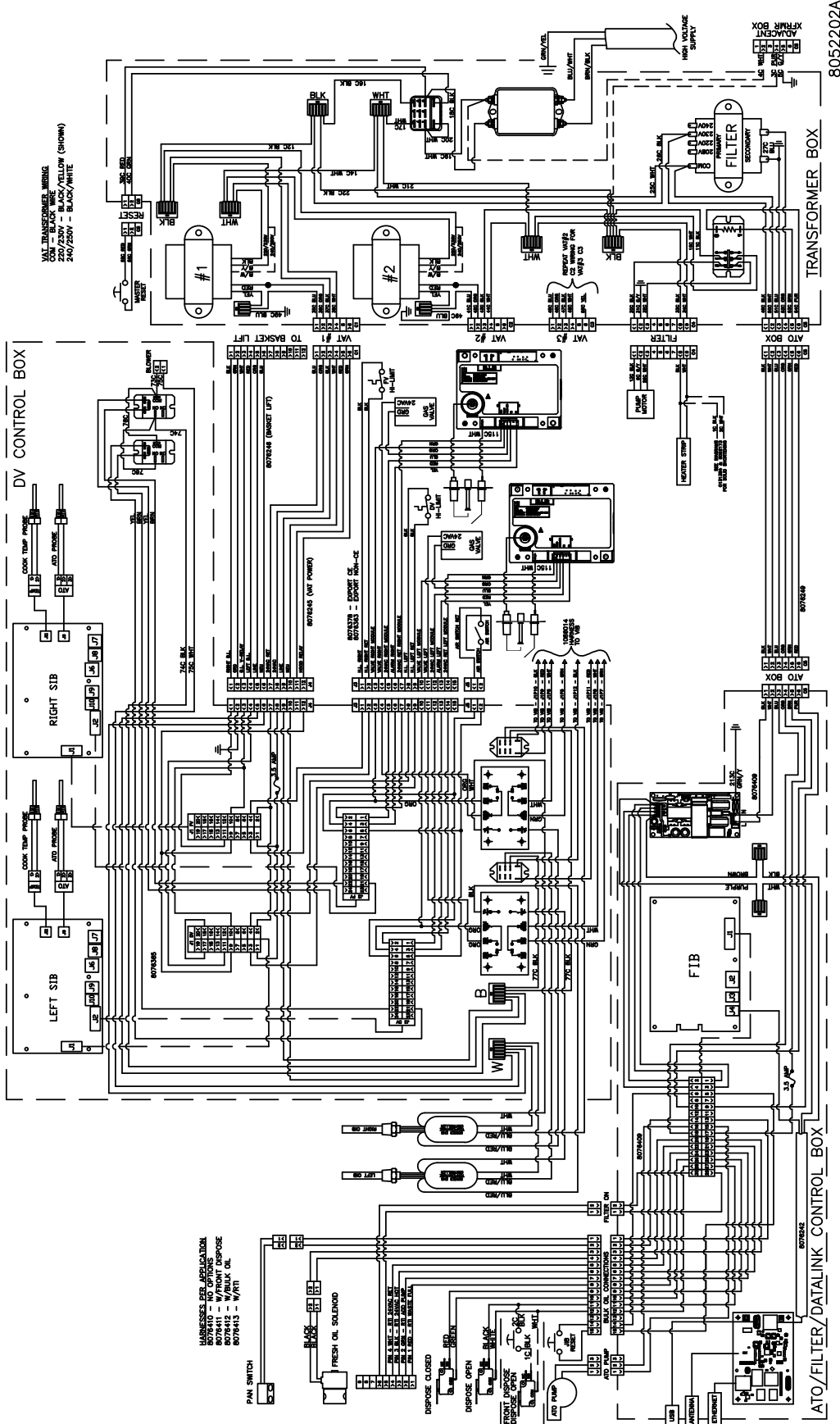

1.24.15 430-530 Transformer Wiring Diagram CE

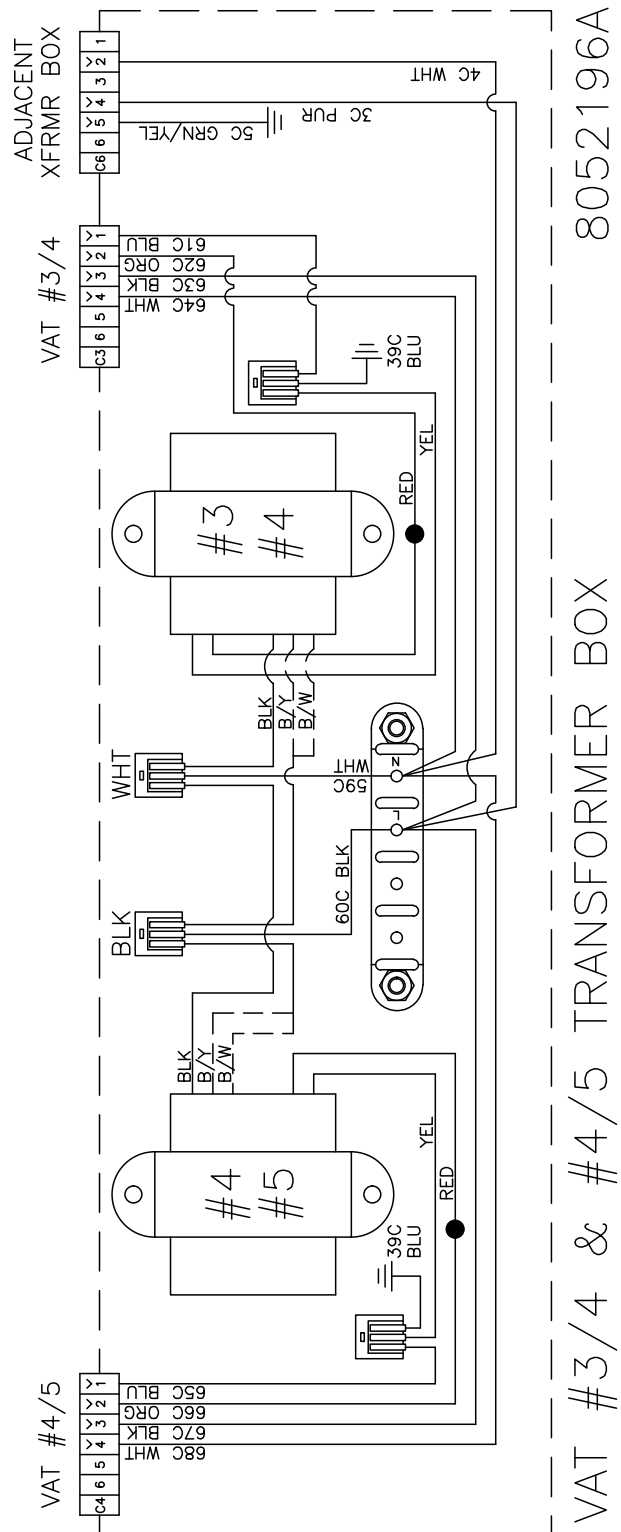

1.24.19 Dual Vat Direct Spark Wiring Diagram Australia with OIB Sensor (After 05/2019)

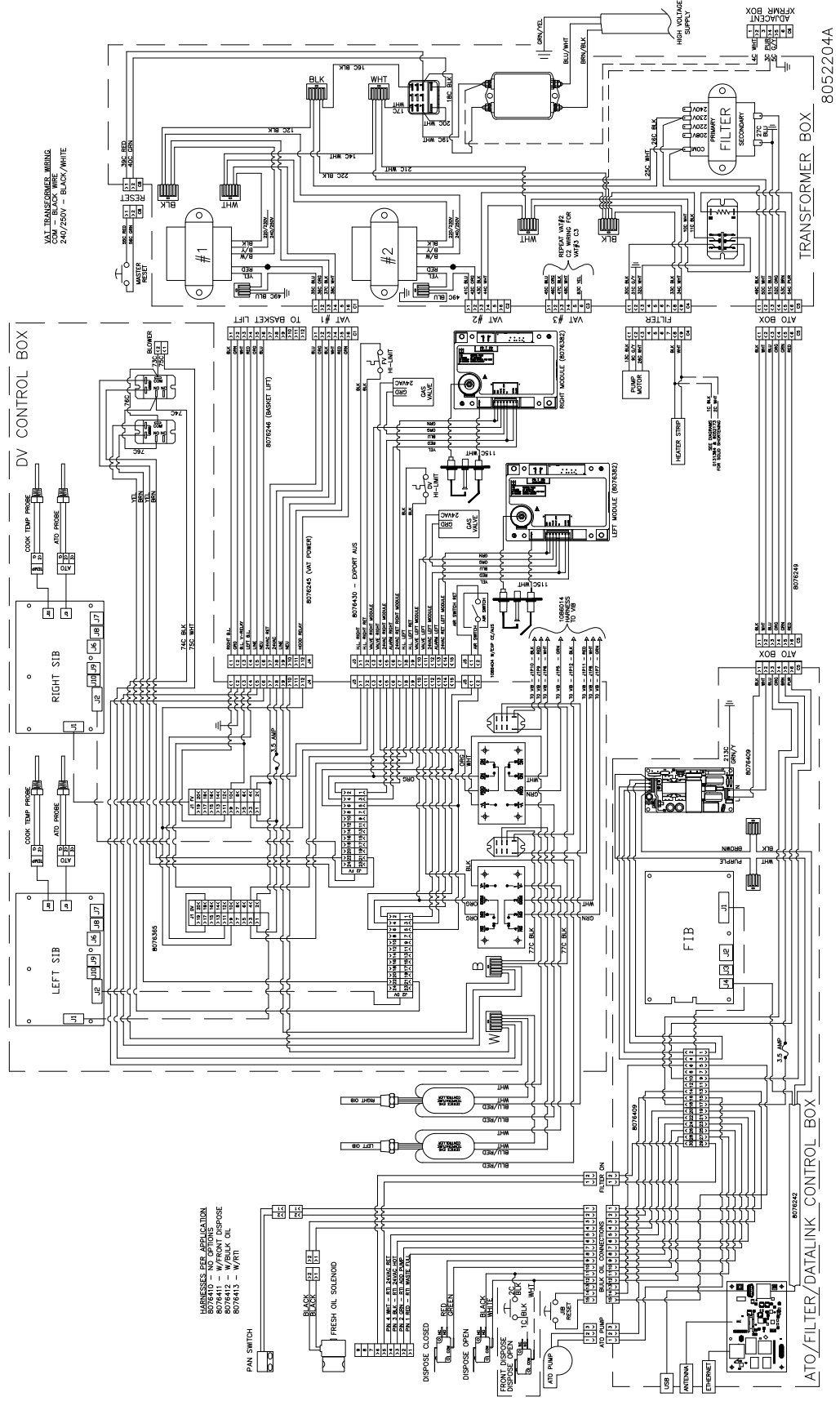

1.24.20 Solid Shortening Melting Unit Wiring Diagram

2 POSITION FRYER HEATER STRIP LAYOUT

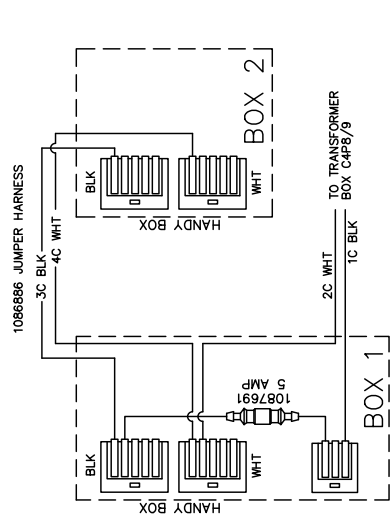

3 POSITION FRYER HEATER STRIP LAYOUT

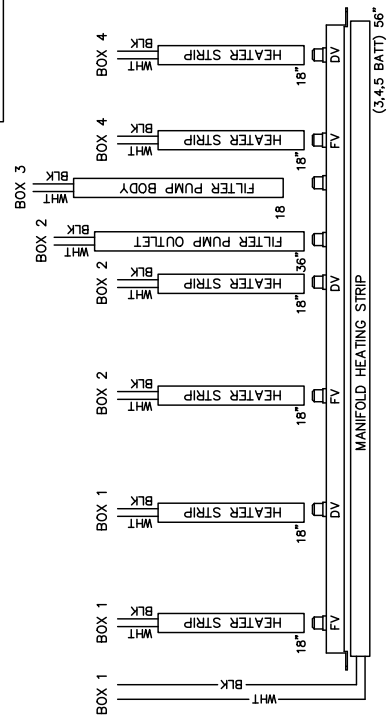
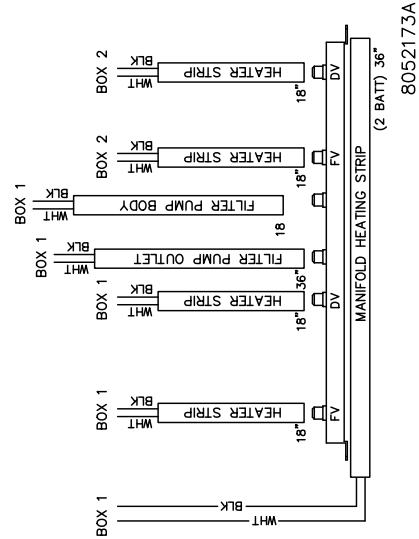
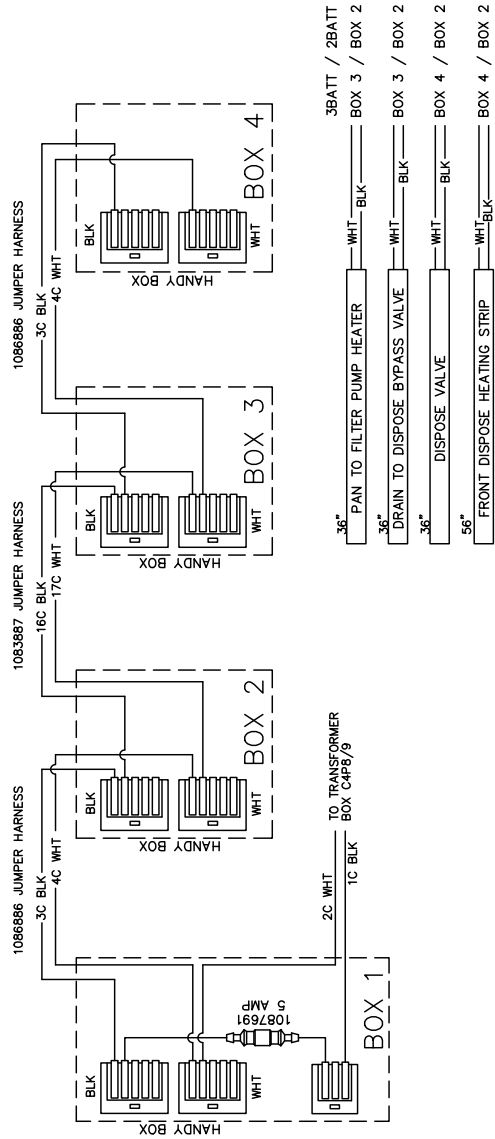

8052173A

1.24.21 Solid Shortening System Wiring Diagram

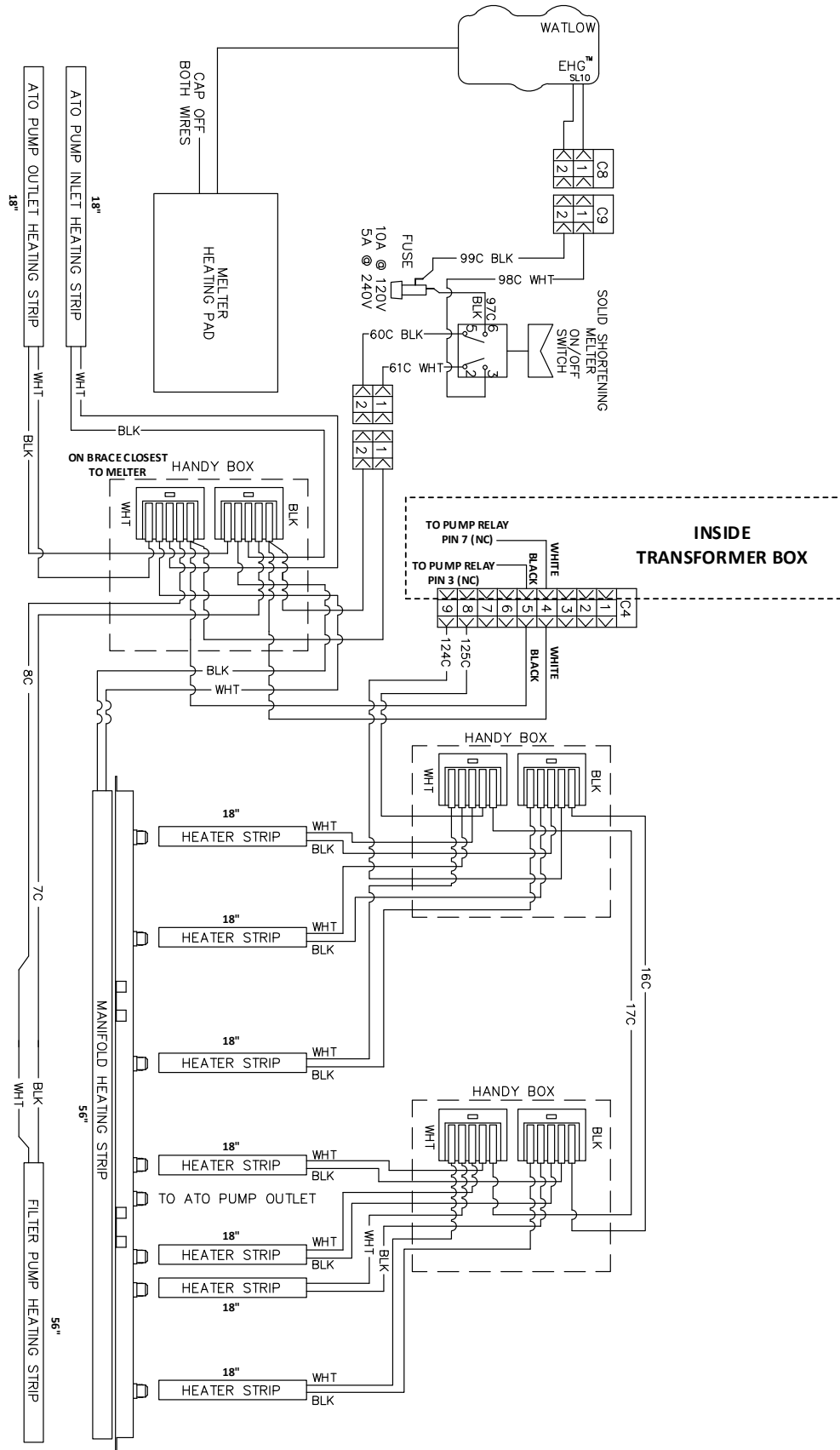

1.24.22 Basketlift Wiring Diagram

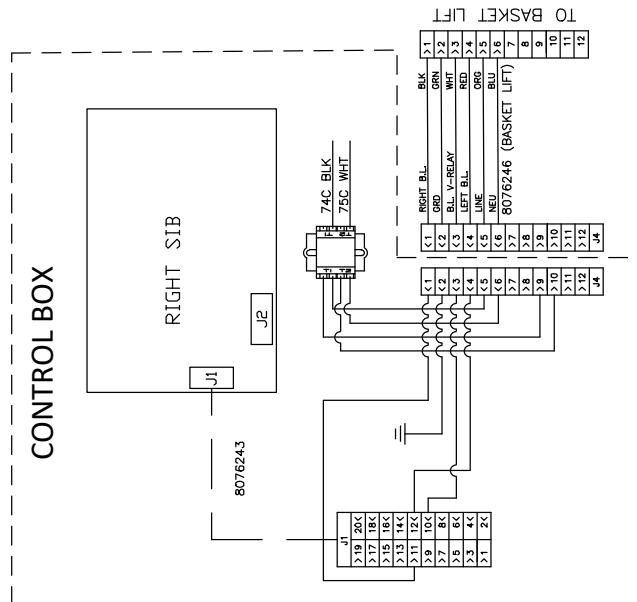
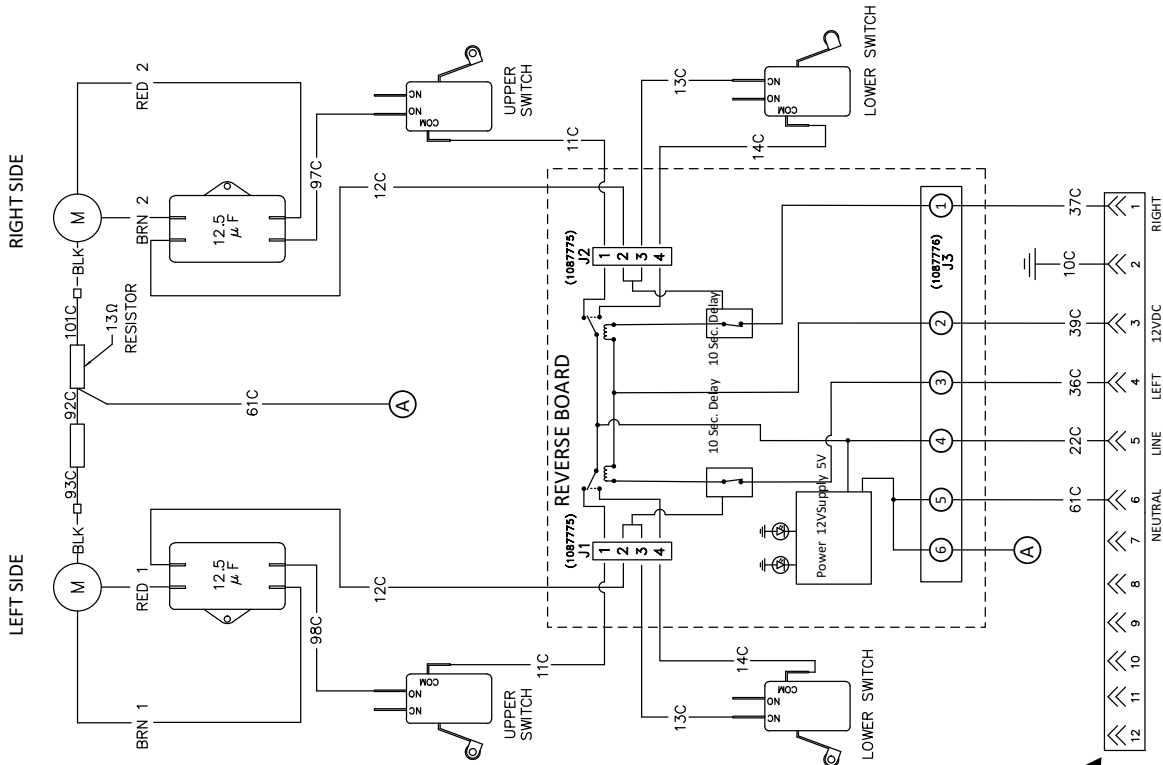

REFERENCES TO LEFT AND RIGHT ARE FROM THE FRONT OF THE FRYER

FILTERQUICK™ 4000 TOUCH SCREEN FRYERS

Appendix A: Bulk Oil Service Issues

A.1 Bulk FIB Tests

These instructions may **NOT** be applicable to all bulk oil systems.

The FilterQuick-T™ fryer will **ONLY** operate with a three-pole float switch for waste oil to determine if the tank is full. If a two-pole switch is used it may cause damage to the FIB board. The float switches are polarity specific which may short to ground and damage an FIB board.

AC voltage measurements from the bulk oil connector on rear of fryer:

Pin 1 to Pin 2 - 24 VAC.

Pin 1 to Pin 4 - 24 VAC when waste tank is full, 0 VAC when it is not full.

Pin 1 to Pin 3 - 24 VAC when bulk fresh oil add switch and pump is on, 0 VAC when it is off.

Troubleshooting

All return and drain valves should be closed and pump should be off while the FIB is resetting. If any of the valves or the pump is on during reset, the FIB board is bad or wires are shorted.

Bulk fresh oil pump is not operating or Oil Reservoir is not filling:

NOTE: DO NOT CHECK PINS WITH HARNESES UNPLUGGED AS SHORTING THE PINS MAY OCCUR WHICH WILL DAMAGE THE BOARD.

Normal measurements (FIB C7 12-pin or rear of FIB box (J1 30-pin) connector with everything connected)

See page A-4 to ensure that no other function is taking priority over adding oil to jug.

1. Reset the power; wait **60 seconds** and see if the valve opens.

With the Orange JIB (Oil Reservoir) button pressed:

2. Voltage at FIB board C7 from Pin 5 to Pin 6 (FIB board J1 from Pin 21 to Pin 22) should be 24 VAC; if not, check connections from bulk fresh oil 24VAC transformer and check transformer.

3. Voltage at FIB board C7 from Pin 6 to Pin 7 (FIB board J1 from Pin 21 to Pin 23) should be 24 VAC when filling JIB or vat; if not, the FIB board is bad or wires to pump relay are shorted or both.

4. Voltage at Fresh Add Pump Relay should be 24 VAC; if not, check wiring from FIB board. The relay is located on top of some fresh oil bulk systems.

Waste full signal:

Voltage at FIB board C7 Pin 5 to Pin 8 (FIB board J1 from Pin 22 to Pin 24) should be 24 VAC when full, 0 VAC when not full; if no voltage level change, the connection from bulk waste full switch or FIB board is bad.

A.2 Bulk Oil Wiring Connection behind Fryer

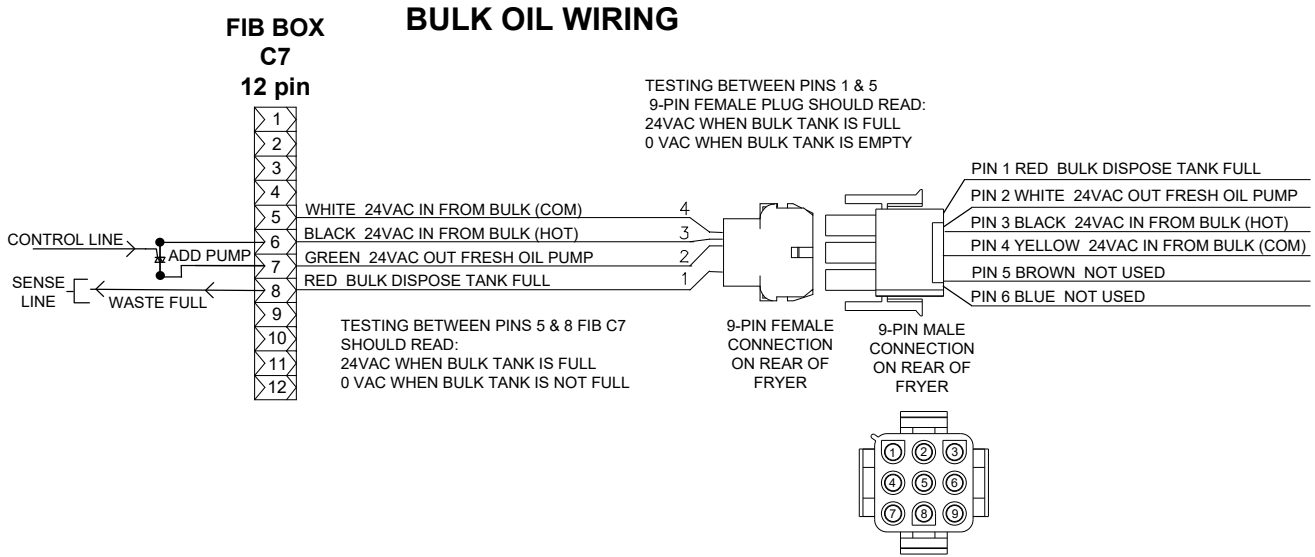

Figure 1

A.3 Frymaster FilterQuick-T Fryer and Bulk Oil System Plumbing Schematic

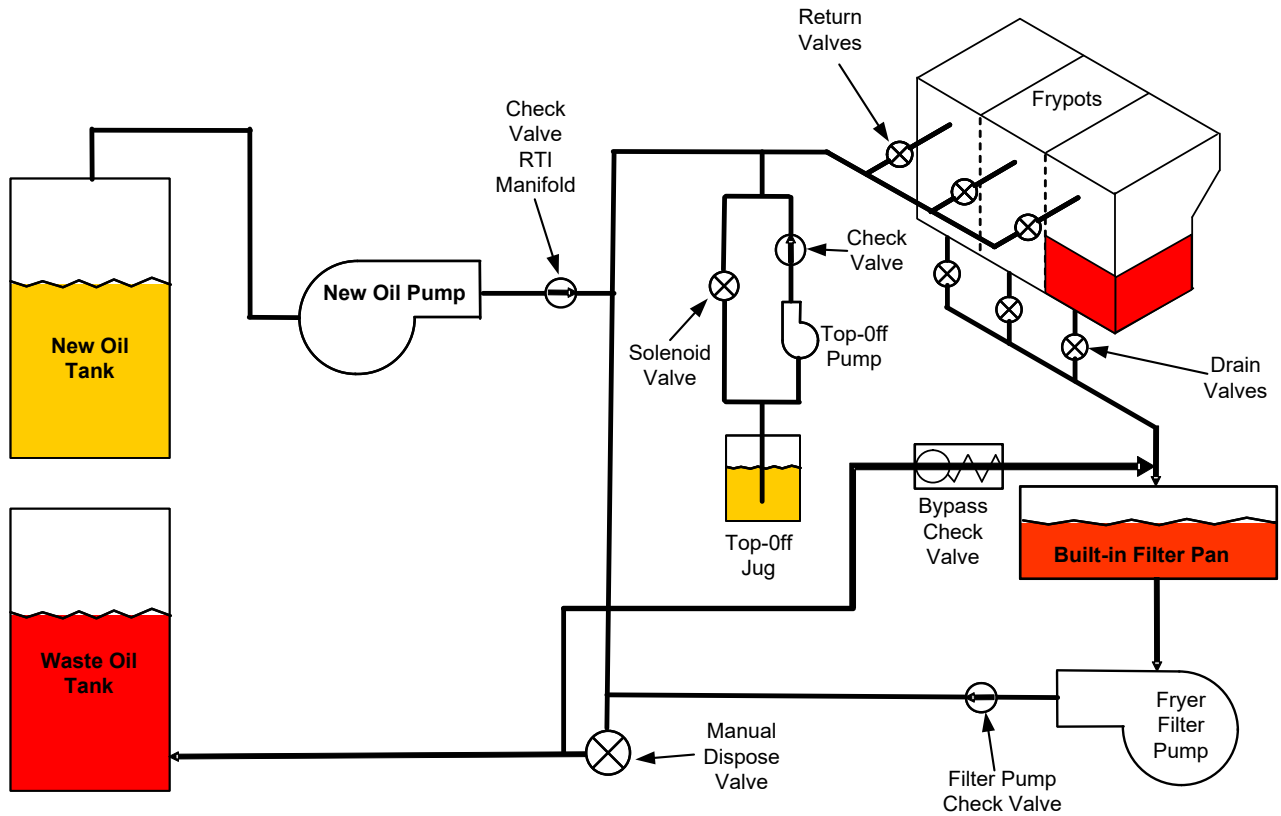

Figure 2

A.4 Bulk Test Quick Reference

A.4.1 DISPOSE TO WASTE, REFILL VAT FROM BULK:



1. Press the filter button.
2. Select LEFT VAT or RIGHT VAT for split vats.
3. Select DISPOSE OIL.
4. "DISPOSE OIL? YES/NO" is displayed. *
5. Press the √ (check) button to dispose of oil in vat.
6. "DRAINING IN PROGRESS" is displayed.
7. "VAT EMPTY? YES" is displayed.
8. Once the vat is empty, press the √ (check) button.
9. "CLEAN VAT COMPLETE? Yes" is displayed.
10. Press the √ (check) button.
11. "OPEN DISPOSE VALVE" is displayed.
12. Open dispose valve.
13. "DISPOSING" is displayed for four minutes.
14. "REMOVE PAN" is displayed.
15. Remove filter pan.
16. "IS PAN EMPTY? YES/NO" is displayed.
17. Press the √ (check) button if the filter pan is empty. Select "NO" if oil remains in the filter pan.
18. "INSERT PAN" is displayed.
19. Insert the filter pan.
20. "CLOSE DISPOSE VALVE" is displayed.
21. Close dispose valve.
22. "FILL VAT FROM BULK? YES/NO" is displayed.
23. Press the √ (check) button.
24. "START FILLING? PRESS AND HOLD" is displayed.
25. Press and hold the button to fill the vat.
26. RELEASE BUTTON WHEN FULL.
27. Release the button when the vat is full.
28. "Continue Filling Yes/No" is displayed
29. Press the √ (check) button to continue filling or press "NO" to exit.

***NOTE:** If the waste tank is full, the controller displays "BULK TANK FULL? YES". Press the √ (check) button and call RTI.

A.4.2 DISPOSE TO WASTE:



1. Press the filter button.
2. Select LEFT VAT or RIGHT VAT for split vats.
3. Select DISPOSE OIL.
4. "DISPOSE OIL? YES/NO" is displayed. *
5. Press the √ (check) button to dispose of oil in vat.
6. "DRAINING IN PROGRESS" is displayed.
7. "VAT EMPTY? YES" is displayed.
8. Once the vat is empty, press the √ (check) button.
9. "CLEAN VAT COMPLETE? Yes" is displayed.
10. Press the √ (check) button.
11. "OPEN DISPOSE VALVE" is displayed.
12. Open dispose valve.
13. "DISPOSING" is displayed for four minutes.
14. "REMOVE PAN" is displayed.
15. Remove filter pan.
16. "IS PAN EMPTY? YES/NO" is displayed.
17. Press the √ (check) button if the filter pan is empty. Select "NO" if oil remains in the filter pan.

18. "INSERT PAN" is displayed.
19. Insert the filter pan.
20. "CLOSE DISPOSE VALVE" is displayed.
21. Close dispose valve.
22. "FILL VAT FROM BULK? YES/NO" is displayed.
23. Press "NO" if you wish to leave vat empty and exit.

A.4.3 FILL VAT FROM BULK:



1. Press the filter button.
2. Select LEFT VAT or RIGHT VAT for split vats.
3. Press the down arrow button.
4. Select FILL VAT FROM BULK.
5. "FILL VAT FROM BULK? YES/NO" is displayed.
6. Press the √ (check) button.
7. "START FILLING? PRESS AND HOLD" is displayed.
8. Press and hold the button to fill the vat.
9. RELEASE BUTTON WHEN FULL.
10. Release the button when the vat is full.
11. "Continue Filling Yes/No" is displayed
12. Press the √ (check) button to continue filling or press "NO" to exit.

A.4.4 FILL OIL RESERVOIR FROM BULK: *

1. When "YELLOW" low oil indicator is illuminated on the controller, and/or TOP OFF OIL EMPTY is displayed, the oil reservoir (top-off container) is empty.
2. To refill reservoir, press and hold the orange reset button above the reservoir until the reservoir is full.
3. Release the button to stop filling.

A.5 Troubleshooting Oil Reservoir Filling

***NOTE: The reservoir may not fill if any of the following are in progress:**

If **FILTRATION REQUIRED – FILTER NOW? YES/NO**, or **SKIM, DEBRIS FROM VAT – PRESS CONFIRM WHEN COMPLETE** are displayed, the fill reservoir button is disabled until either a filter is complete or until NO is chosen.

The system also checks these conditions. The following must be met before an oil reservoir fill is allowed:

- Solenoid closed
- Orange fill button pressed longer than 3 sec.
- FILTRATION REQUIRED – FILTER NOW? YES/NO, or SKIM, DEBRIS FROM VAT – PRESS CONFIRM WHEN COMPLETE cannot be displayed
- System power cycle (all boards – Controllers, SIB, VIB and FIB) after changing setup from JIB to Bulk (use momentary reset). Ensure reset is pressed and held for at least **sixty (60) seconds**.
- No filtration or other filter menu selection can be in process.

Other factors that may not allow fill reservoir from bulk –

- Defective solenoid
- Defective orange reset switch
- Bulk oil pump issue
- Bulk oil relay stuck

If using two fryer systems that are both attached to the bulk oil system, they may not be able to fill both units at the same time if they have a bulk fresh oil unit with a single head. Some bulk oil fresh units have dual heads which can fill simultaneously.

THIS PAGE INTENTIONALLY LEFT BLANK

Frymaster[®]

FRYMASTER
8700 LINE AVENUE, SHREVEPORT, LA 71106-6800

800-551-8633

318-865-1711

WWW.FRYMASTER.COM

EMAIL: FRYSERVICE@WELBILT.COM



Welbilt offers fully-integrated kitchen systems. Welbilt's portfolio of award-winning brands includes Cleveland™, Convotherm®, Crystal Tips®, Dean®, Delfield®, Fabristeel®, Frymaster®, Garland®, Inducs®, Koldtech®, Kolpak®, Lincoln®, McCann's™, Merco®, Merrychef®, Multiplex®, RDI®, SerVend™, SunFire®, U.S. Range™, and WMaxx™. Supported by service brands: FitKitchen®, kitchen systems; and KitchenConnect®, cloud-based open platform.

Bringing innovation to the table • welbilt.com

©2023 Frymaster LLC. except where explicitly stated otherwise. All rights reserved. Continuing product improvement may necessitate change of specifications without notice.

Part Number FRY_SM_8197477 10/2023