



Beginning with Series Code AN

H14/H17/H22 SERIES ELECTRIC FRYERS

Service & Parts Manual



Frymaster, a member of the Commercial Food Equipment Service Association, recommends using CFESA Certified Technicians.

24-Hour Service Hotline 1-800-551-8633

SEP 2022



NOTICE

IF, DURING THE WARRANTY PERIOD, THE CUSTOMER USES A PART FOR THIS FRYMASTER DEAN EQUIPMENT OTHER THAN AN UNMODIFIED NEW OR RECYCLED PART PURCHASED DIRECTLY FROM FRYMASTER DEAN, OR ANY OF ITS AUTHORIZED SERVICE CENTERS, AND/OR THE PART BEING USED IS MODIFIED FROM ITS ORIGINAL CONFIGURATION, THIS WARRANTY WILL BE VOID. FURTHER, FRYMASTER DEAN AND ITS AFFILIATES WILL NOT BE LIABLE FOR ANY CLAIMS, DAMAGES OR EXPENSES INCURRED BY THE CUSTOMER WHICH ARISE DIRECTLY OR INDIRECTLY, IN WHOLE OR IN PART, DUE TO THE INSTALLATION OF ANY MODIFIED PART AND/OR PART RECEIVED FROM AN UNAUTHORIZED SERVICE CENTER.

 DANGER

Copper wire suitable for at least 167°F (75°C) **MUST** be used for power connections.

 DANGER

The electrical power supply for this appliance **MUST** be the same as indicated on the rating and serial number plate located on the inside of the fryer door.

 DANGER

This appliance **MUST** be connected to the voltage and phase as specified on the rating and serial number plate located on the inside of the fryer door.

 DANGER

All wiring connections for this appliance **MUST** be made in accordance with the wiring diagrams furnished with the equipment. Wiring diagrams are located on the inside of the fryer door.

 DANGER

Do not store or use gasoline or other flammable vapors and liquids in the vicinity of this or any other appliance.

 WARNING

Do not attach accessories to this fryer unless fryer is secured from tipping. Personal injury may result.

⚠ WARNING

Frymaster fryers equipped with legs are for permanent installations. Fryers fitted with legs must be lifted during movement to avoid damage and possible bodily injury. For a moveable or portable installation, Frymaster optional equipment casters must be used.

Questions? Call 1-800-551-8633

⚠ WARNING

Do not use water jets to clean this equipment.

⚠ DANGER

All wiring connections for this appliance MUST be made in accordance with the wiring diagrams furnished with the equipment. Wiring diagrams are located on the inside of the fryer door.

⚠ WARNING

This equipment is intended for indoor use only. Do not install or operate this equipment in outdoor areas.

Electrical Requirements

MODEL	VOLTAGE	PHASE	WIRE SERVICE	MIN. SIZE	AWG (mm ²)	AMPS PER LEG		
						L1	L2	L3
H14	208	3	3	6	(16)	39	39	39
H14	240	3	3	6	(16)	34	34	34
H14	480	3	3	8	(10)	17	17	17
H14	220/380	3	4	6	(16)	21	21	21
H14	240/415	3	4	6	(16)	20	20	21
H14	230/400	3	4	6	(16)	21	21	21
ALL EPH14 SERIES (SOLID STATE)	208	3	3	6	(16)	39	39	39
	240	3	3	6	(16)	34	34	34
	220/380	3	4	6	(16)	21	21	21
	240/415	3	4	6	(16)	20	20	20
H17	208	3	3	6	(16)	48	48	48
H17	240	3	3	6	(16)	41	41	41
H17	480	3	3	6	(16)	21	21	21
H17	220/380	3	4	6	(16)	26	26	26
H17	240/415	3	4	6	(16)	24	24	24
	230/400	3	4	6	(16)	25	25	25
ALL	208	3	3	6	(16)	48	48	48
EPH17 SERIES (SOLID STATE)	240	3	3	6	(16)	41	41	41
	220/380	3	4	6	(16)	26	26	26
	240/415	3	4	6	(16)	24	24	24
	H22	208	3	3	4	(25)	61	61
H22	240	3	3	4	(25)	53	53	53
H22	480	3	3	6	(16)	27	27	27
H22	220/380	3	4	6	(16)	34	34	34
H22	240/415	3	4	6	(16)	31	31	31
H22	230/400	3	4	6	(16)	32	32	32

TABLE OF CONTENTS

	Page #
CHAPTER 1 – SERVICE PROCEDURES	1-1
1.1 General	1-1
1.2 Replace Computer Controller	1-1
1.3 Replace Interface Board	1-2
1.4 Replace Transformer	1-3
1.5 Replace Temperature Probe	1-3
1.6 Replace Heating Element	1-6
1.7 Replace High-Limit	1-9
1.8 Replace Frypot	1-10
1.9 Replace Contactor	1-10
1.10 Built-in Filter System Service Procedures	1-12
1.11 Basket Lift Service Procedures	1-17
1.12 Electric Interface Board Diagnostic Chart	1-20
1.13 Simplified Wiring Diagrams, Common Electric	1-21
1.14 Wiring Diagrams, Main	1-26
1.15 Wiring Diagrams, Basket Lifts	1-32
1.16 Wiring Diagrams, Filtration Systems	1-34
CHAPTER 2 – PARTS LIST	2-1
2.1 Accessories	2-1
2.2 Basket Lift Assemblies and Component Parts	2-2
2.3 Cabinet Assemblies and Component Parts	2-4
2.4 Casters, Legs and Associated Hardware	2-12
2.5 Component Box Assemblies and Associated Hardware	2-14
2.6 Control Panels Assemblies, Doors, and Related Components	2-15
2.7 Controller Assemblies	2-17
2.8 Electrical Components	2-18
2.9 Filter Base/Pan Assemblies	2-25
2.10 Filter Pump and Motor Assemblies and Associated Hardware	2-33
2.11 Drain System Components	2-38
2.12 Filtration System Components	2-39
2.13 Frypot Assemblies and Drain Valve Components	2-42
2.14 High-Limit Thermostat and Related Components	2-44

H14/H17/H22 SERIES ELECTRIC FRYERS

CHAPTER 1: SERVICE PROCEDURES

1.1 General

Before performing any maintenance on your Frymaster fryer, you must disconnect the electrical power supply.

When electrical wires are disconnected, it is recommended that they be marked in such a way as to facilitate re-assembly.

1.2 Replace Computer/Controller

1. Unscrew and remove two control panel screws.



2. Control panel is hinged at the bottom and will swing open from the top.

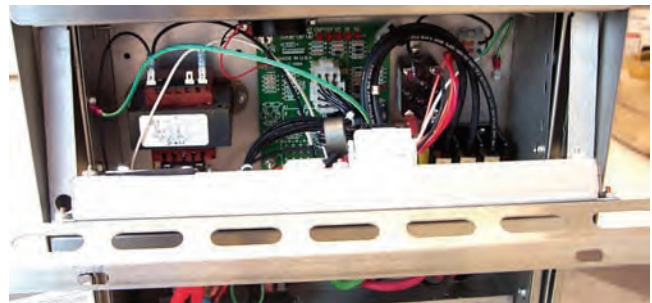

3. Unplug wiring harness at plug on back of controller.

4. Control panel including controller can be removed by lifting the assembly from the hinged slots in the control panel frame.



5. Reverse procedures to install new controller.

1.3 Replace Interface Board

1. Unplug all power cords. Perform Procedure 1.2, Steps 1-4, Replace Computer/Controller.
2. Unplug wire harness from the interface board. Remove all wiring from the terminals of the interface board, ensuring that each wire is marked for reattachment.

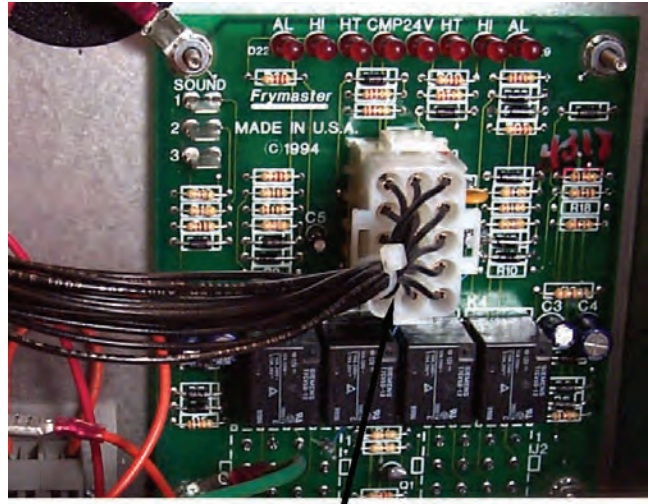

Wire harness/connector

3. Remove the screws securing the control panel frame. Set the control panel frame/screws aside.
4. Remove the screws securing the top cap. Set the top cap/screws aside.
5. Remove the screws securing the component box. Set the component box drop down enough so that the wire harness can be unplugged from the back of the assembly.

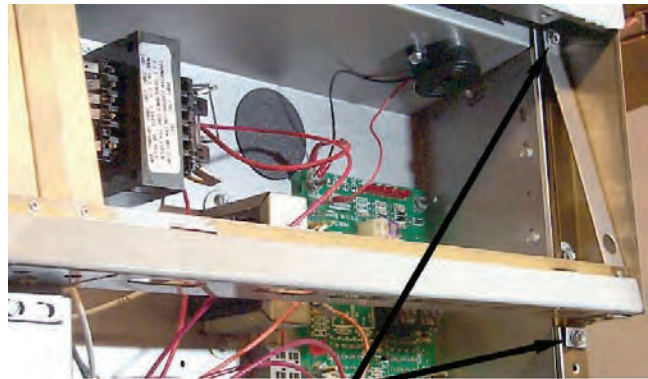

Screws securing control panel frame

6. Remove the nuts from each corner of the interface board and slide the board from the studs. Ensure that standoffs remain in place on studs, prior to installing new interface board. Install the new interface board by reversing the previous procedures. Ensure that wire harnesses are connected to back of interface board prior to securing component box. Also ensure that wiring and wire harnesses are connected to the proper terminals.

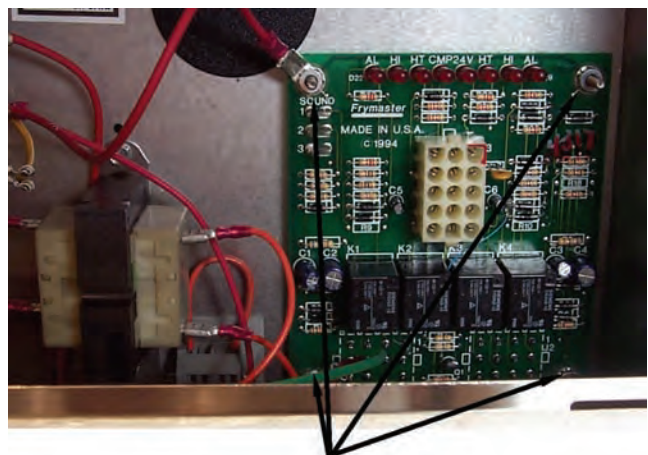

Nuts securing interface board

1.4 Replace Transformer

1. Unplug all power cords. Perform Procedure 1.2, Steps 1-4, Replace Computer/Controller.
2. Remove all wiring from the terminals of the transformer to be replaced.
3. Remove the screws that secure the transformer to the component box.
4. Install the new transformer by reversing the preceding procedures. Make sure you reconnect the wiring to the proper terminals and the harnesses to the correct connectors.

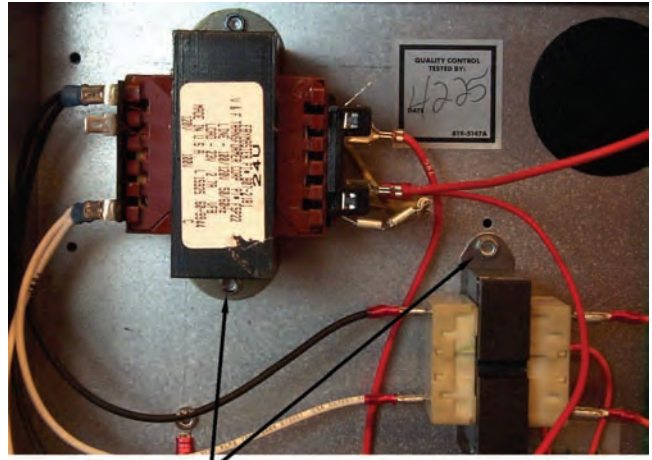

Screws securing transformers

1.5 Replace Temperature Probe

1. Unplug fryer from the electrical source.
2. Drain the cooking oil from the frypot.
3. Remove the fryer from the exhaust hood to gain access to the rear of the fryer.
4. Remove the screws from the top, center and bottom back covers. Set the covers and screws aside.
5. Remove the screws securing the tilt housing cover. Set the tilt housing cover aside.



Screws securing back covers and tilt housing

6. Disconnect the wire harness containing the probe wiring. It may be necessary to remove the wire ties.
7. Use a pin-pusher (P/N 806-4855 or P/N 807-0928—see Section 1.7) to remove the probe wires from the connector. Mark each wire for re-assembly.

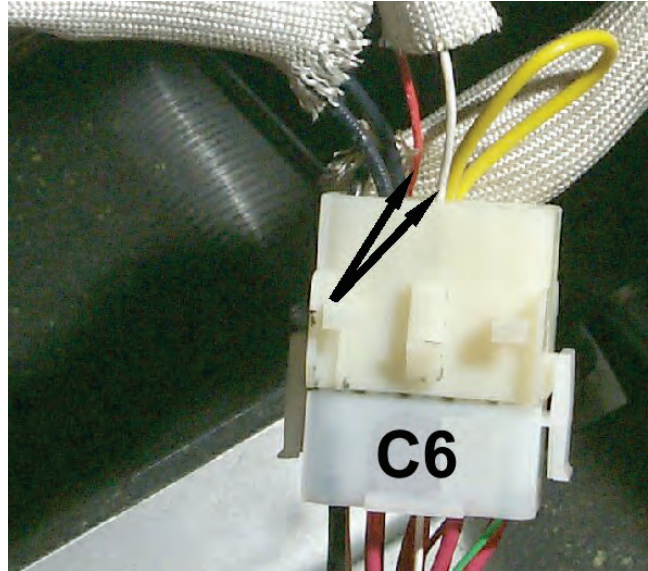

Use a pin-pusher to remove probe wires from connector

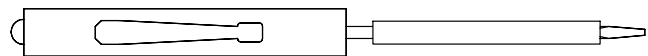

Pin-pusher (Frymaster P/N 806-4855)

8. Remove the screw(s) securing the probe bracket to the element.

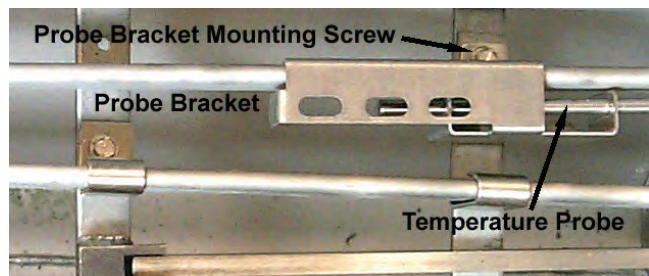

9. Thread the probe wire through the hole in the tilt plate assembly and remove the probe and the securing components from the element.
10. Remove the probe from the probe bracket. Place the new probe into the bracket.



Thread probe wire through hole in tilt plate assembly, then remove probe and components from element.

11. Place the new temperature probe assembly onto the element and secure with the screws removed earlier. Clip the probe onto the rear of the element. The temperature probe assembly should be oriented in the same manner as the probe being replaced.
12. Thread the probe wires into the harness connector as removed in Step 7.
13. Lower the element into the frypot.

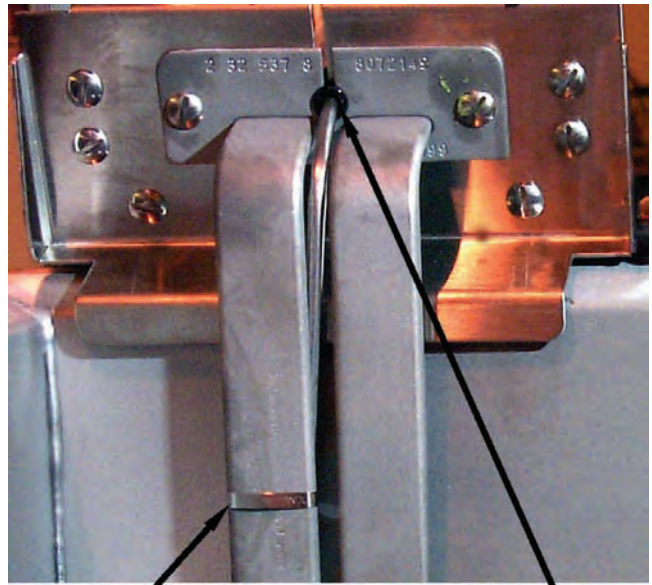

Secure probe to element with metal wire-wrap

New probe assembly properly installed in tilt plate

14. Place the tilt housing cover over the tilt housing assembly and secure with screws
15. Install the top, center and bottom back covers and secure with screws.

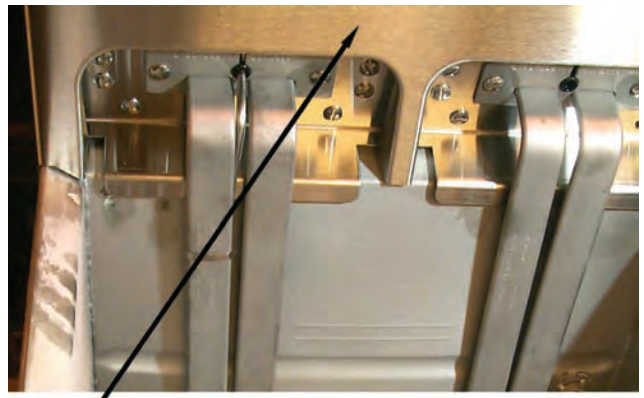

Tilt housing cover in place

1.6 Replace Heating Element

1. Perform Procedure 1.5, Replace Temperature Probe, Steps 1-7.

2. Remove the element wires from the connector. Press down on either side of the connector while pulling up on the top portion. The connector will open from the top. Pull all wires from the connector.

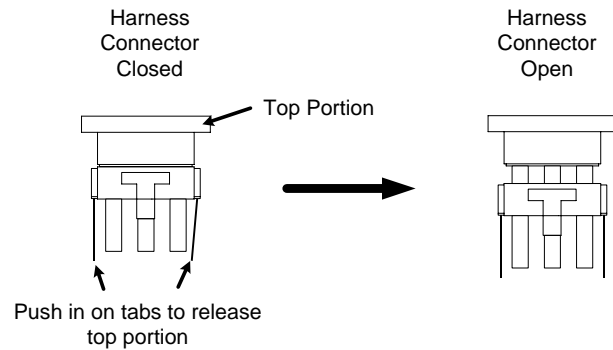

3. Remove the screws securing the temperature probe bracket from the element. Remove the probe clamp (metal wire-wrap). Set the temperature probe and probe-securing components aside.

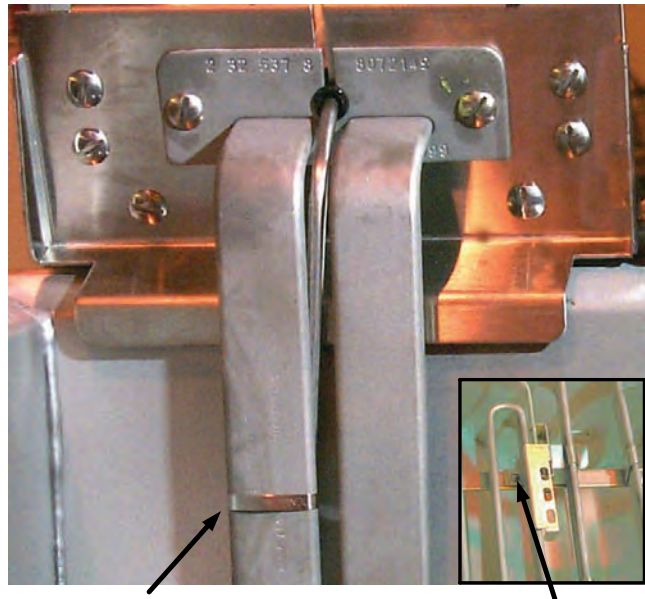

Remove probe clamp (metal wire-wrap), and screws securing probe bracket to element.

4. Disconnect the element springs.



Disconnect element springs here

5. Remove the element mounting-screws and pull the element out of the frypot (split-vats). On full-vat elements, remove the element clamps and hardware before removing mounting-screws and nuts on the defective element.
6. Install the replacement element in the frypot and secure with the mounting screws removed in Step 5.
7. Re-install the temperature probe and probe-securing components onto the replacement element.

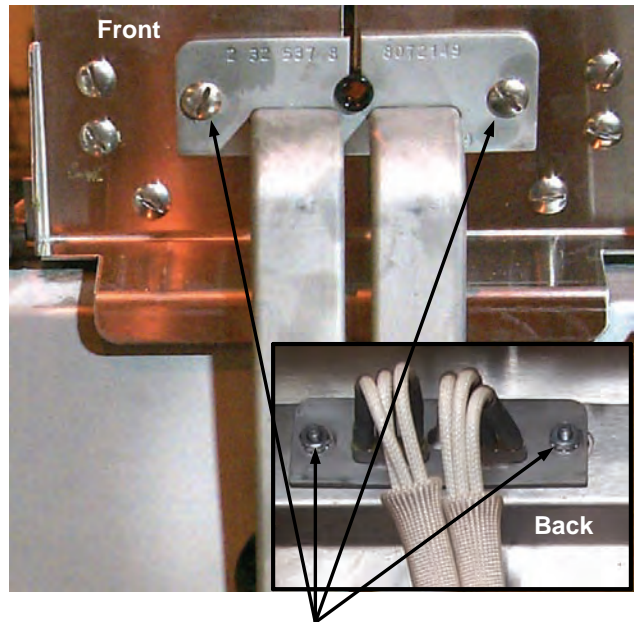

Element mounting-screws and nuts. (Inset Photo-back of tilt plate)

8. Route the element leads (terminals) to the rear of the fryer. Ensure that chafing guards are in place to prevent wire chafing while raising and lowering elements.

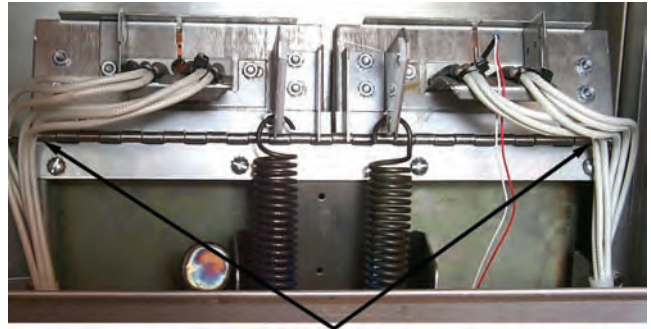

Proper element-wire routing is essential to prevent wire chafing while raising and lowering elements.

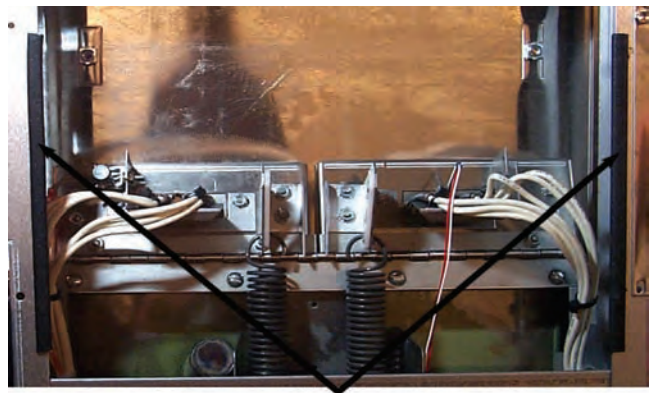

Chafing guards on cabinet edges also help prevent wire chafing while raising and lowering elements.

9. When replacing the right element (as viewed from the rear of the fryer), insert pin terminals into the corresponding pin-holes in the 6-pin connector. When all pin terminals have been fully inserted, close the connector by sliding the halves together until the tabs snap back into place (reverse procedure in Step 2).

10. When replacing the left element (as viewed from the rear of the fryer), use the 9-pin connector, inserting the leads from the replacement element and closing the connector, see previous step.

11. Insert the connector(s) into the receptacle(s) on the rear of the contactor box, ensuring that the latches lock the connectors in place (see Step 9).

12. Install the temperature probe wires (marked for re-assembly) in the corresponding pin locations.

13. Reconnect the element spring.

14. Place the tilt housing cover over the tilt housing assembly and secure with screws.

15. Install covers and secure with screws.

16. Position fryer under exhaust hood.

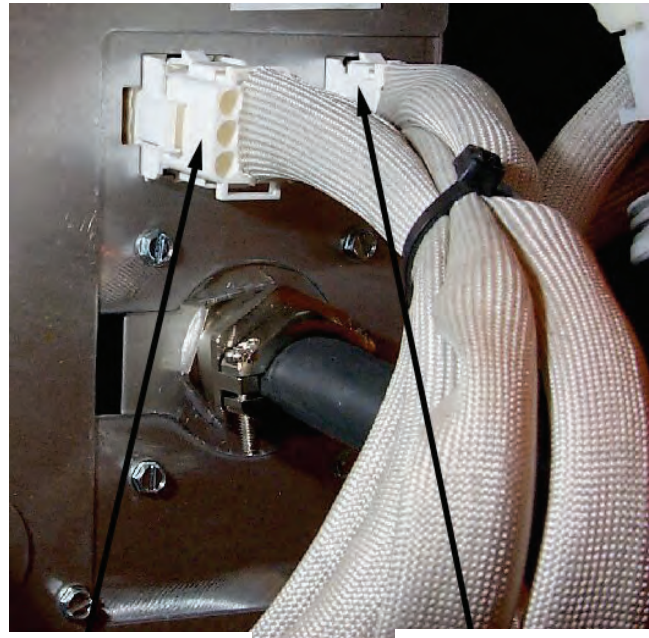

Left Element—
9-Pin Connector

Right Element—
6-Pin Connector

1.7 Replace High-Limit

1. Perform Procedure 1.5, Replace Temperature Probe, Steps 1-4.
2. Disconnect the wire harness containing the high-limit wires.
3. Use a pin-pusher (P/N 806-4855 or P/N 807-0928) to remove the two high-limit wires from the wire harness connector. For split-pot fryers, remove only the wires for the high-limit to be replaced. Mark each wire for re-assembly.
4. Remove the high-limit from the frypot using an open-end wrench or other suitable tool.
5. Apply Loc-Tite PST 567 sealant to the replacement high-limit threads.
6. Screw the replacement high-limit into the frypot and tighten securely. **DO NOT OVERTIGHTEN.**
7. Insert the replacement high-limit wires into the proper pin-holes in the connector. The same two pin-holes from which the defective high-limit wires were removed.
8. Reconnect the wire harness connector.
9. Install and secure the back covers.
10. Position the fryer under the exhaust hood.

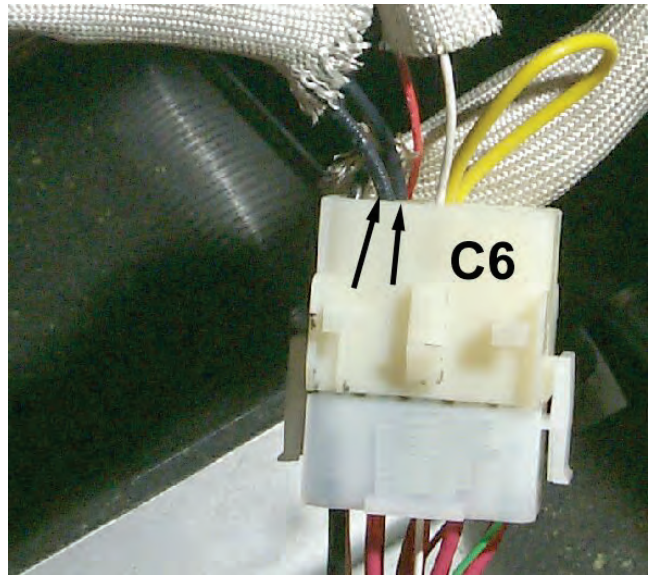

Proper element-wire routing is essential to prevent wire chafing while raising and lowering elements.



Pin Pusher— P/N 807-0928



Place wrench here when removing and installing high-limit.

1.8 Replace Frypot

1. Perform Procedure 1.5, Replace Temperature Probe, Steps 1-7.
2. Perform Procedure 1.2, Replace Computer/Controller, Steps 1-6.
3. Disconnect the wire harness containing the high-limit wires.
4. Use a pin-pusher to remove the high-limit wires from the wire harness connector.
5. Remove the high-limit from the frypot.
6. Disconnect the wire-harnesses connected to the contactor box.
7. Remove the screws securing the capping piece from the fryer. Remove the capping piece and set aside. It may be necessary to remove the wiring covers from the front of the contactor box.
8. If the fryer has a built-in filtration system, remove all the plumbing from the frypot, including rear-flush and square-drain plumbing.
9. Remove the screws securing the frypot to the front frame of the fryer.
10. Carefully lift the frypot from the cabinet.
11. Remove the drain valve from the old frypot and install on the new frypot.
12. Apply Loc-Tite Sealant PST 567 to the high-limit threads. Install the high-limit into the new frypot.
13. Disconnect the tilt plate springs from the old frypot.
14. Remove the securing screws from the tilt plate. Lift the tilt plate/heating element assembly from the old frypot and install on the new frypot.
15. Follow the preceding steps in reverse to install the new frypot into the fryer.
16. NOTE: Apply Loc-Tite Sealant PST 567 to all pipefittings prior to installation.

1.9 Replace Contactor

1. Perform Procedure 1.4, Replace Temperature Probe, Steps 1-3.
2. Remove the screws securing the bottom and center rear access covers. Set the screws and covers aside.

3. If present, remove the screws securing the wiring covers to the front of the contactor box (**optional on old-style contactor boxes**). Set the screws and covers aside.
4. Disconnect the wire harnesses from the front and rear of the contactor box.

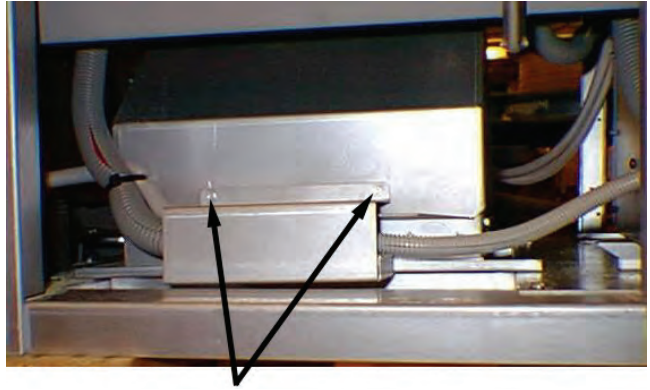

Screws securing wire cover to contactor box (optional on old-style contactor boxes)

5. Remove the screws securing the contactor box to the bottom frame of the fryer.
6. Pull the contactor box through the access opening in the rear of the fryer.
7. Remove the screws securing the contactor box cover. Set the screws and covers aside.

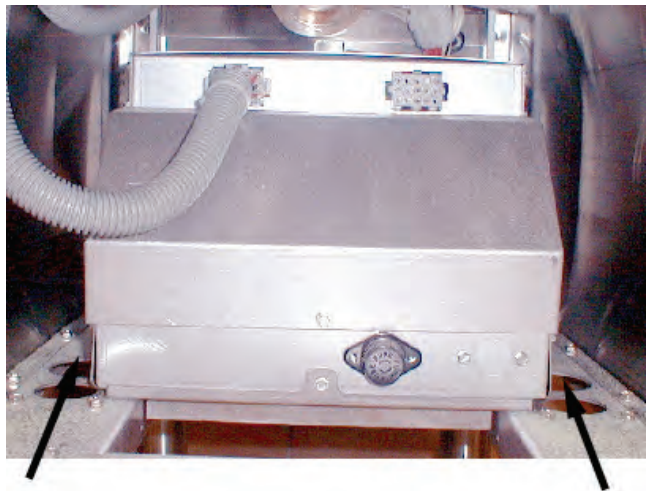

Screw location securing contactor box to bottom frame

8. Remove all wiring connected to the contactor terminals inside the contactor box. Mark each wire for re-assembly.

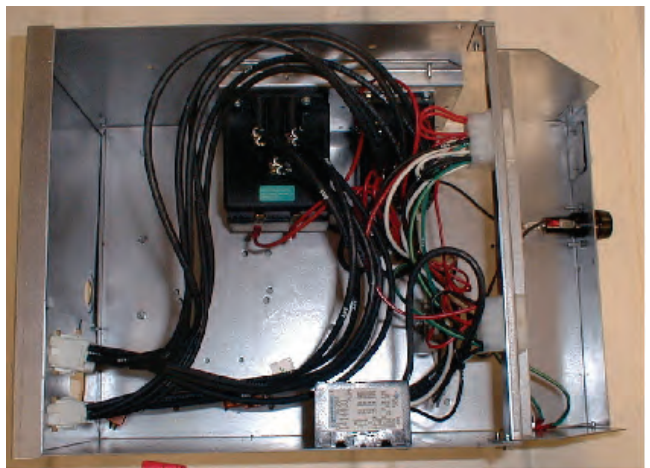

Mark each wire for re-assembly, then remove all wiring connected to the contactor(s) to be replaced.

9. Remove the contactor mounting screws and remove the contactor.

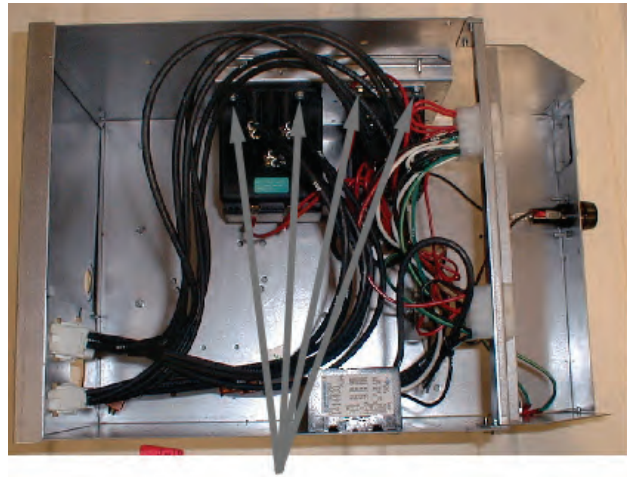

Contactor mounting screws

10. Install the new contactor and connect the wiring removed in Step 8.
11. Install the contactor box by following the previous steps in reverse order.

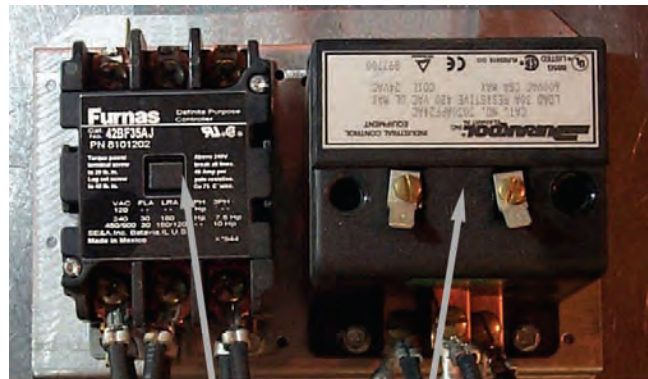

Latching Contactor Mercury Contactor

1.10 Built-in Filter System Service Procedures

Filtration Problem Resolution

One of the most common errors is placing the filter paper on the bottom of the filter pan rather than over the filter screen.

CAUTION

Ensure that filter screen is in place prior to filter paper placement and filter pump operation. Improper screen placement is the major cause of filter system malfunction.

Whenever the complaint is “the pump is running, but no oil is being filtered,” check the installation of the filter paper, and ensure that the correct size is being used. While you are checking the filter paper, verify that the O-ring on the bottom of the filter pan is present and in good condition. A missing or worn O-ring allows the pump to take in air and decreases its efficiency. Also, oil leaks on the floor each time a vat is drained.

If the pump motor overheats, the thermal overload will trip and the motor will not start until it is reset. If the pump motor does not start, press the red reset switch (button) located on the rear of the motor.

If the pump starts after resetting the thermal overload switch, then something is causing the motor to overheat. A major cause of overheating is when several frypots are filtered sequentially, thus overheating the pump and motor. Allow the pump motor to cool at least 30 minutes before resuming operation.

Pump overheating can be caused by:

- Solidified shortening in the pan or filter lines,
- or
- Attempting to filter unheated oil or shortening.

Cold oil and shortening are more viscous, causing the pump motor to load up and overheat.

If the motor runs but the pump does not, there is a blockage in the pump. Incorrectly sized or installed paper/pads will allow food particles and sediment to pass through the filter pan and into the pump. When sediment enters the pump, the gears bind, causing the motor to overload, again tripping the thermal overload. Shortening that has solidified in the pump will also cause it to seize, with the same result.

A pump seized by debris or hard shortening can usually be freed by manually moving the gears with a screwdriver or other instrument.

Disconnect power to the filter system.

Remove the input plumbing from the pump.



Reset switch location: Old-style FP111



Reset switch location: New-style FP111

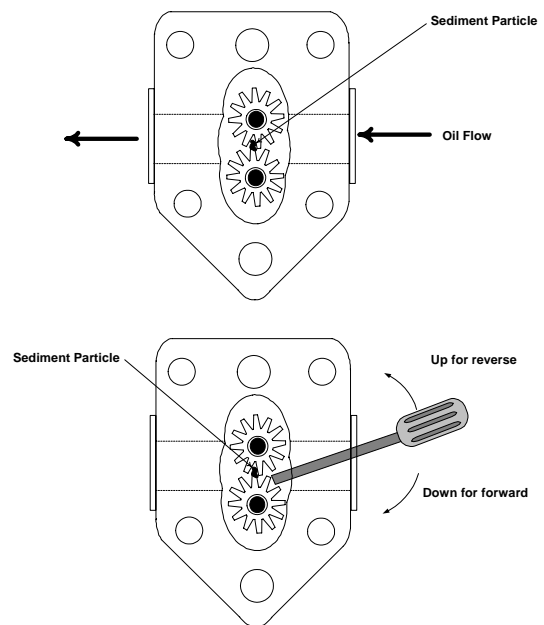

Freeing a seized pump.

Use a screwdriver to manually turn the gears, in which:

- Turning the pump gears in reverse will release a hard particle.
- Turning the pump gears forward will push softer objects and solid shortening through the pump and allow free movement of the gears.

Incorrectly sized or installed paper/pads will also allow food particles and sediment to pass through and clog the suction tube on the bottom of the filter carriage. Particles large enough to block the suction tube may indicate that the crumb tray is not being used.

Pan blockage can also occur if shortening is left in the pan and allowed to solidify. The heater strip on the suction tube is designed to prevent residual shortening from solidifying in the tube. Heater strips do not prevent residual shortening from solidifying in the pan.

Blockage removal can be accomplished by forcing the item out with an auger or drain snake. Compressed air or other pressurized gases should not be used to force out the blockage.

For FootPrint III systems built before October, 1999, all heater tapes are wired directly into the line VAC source (see wiring diagram, page 1-15). They remain energized as long as the unit is plugged in. In systems built in October, 1999 and later, oil return line heater tapes have been eliminated. In these units, the only heater tape used is on the suction tube and pump. This tape is still wired directly into the line voltage. A pair of vacuum-breaking solenoids is wired into the 24 VAC circuit.

The redesigned FP III is distinguished from the original design by the absence of casters on the filter base assembly. The redesign incorporated an improved oil return system that allows oil/shortening to drain back to the filter pan when the filter system is turned off, eliminating the need for most heated oil return components.

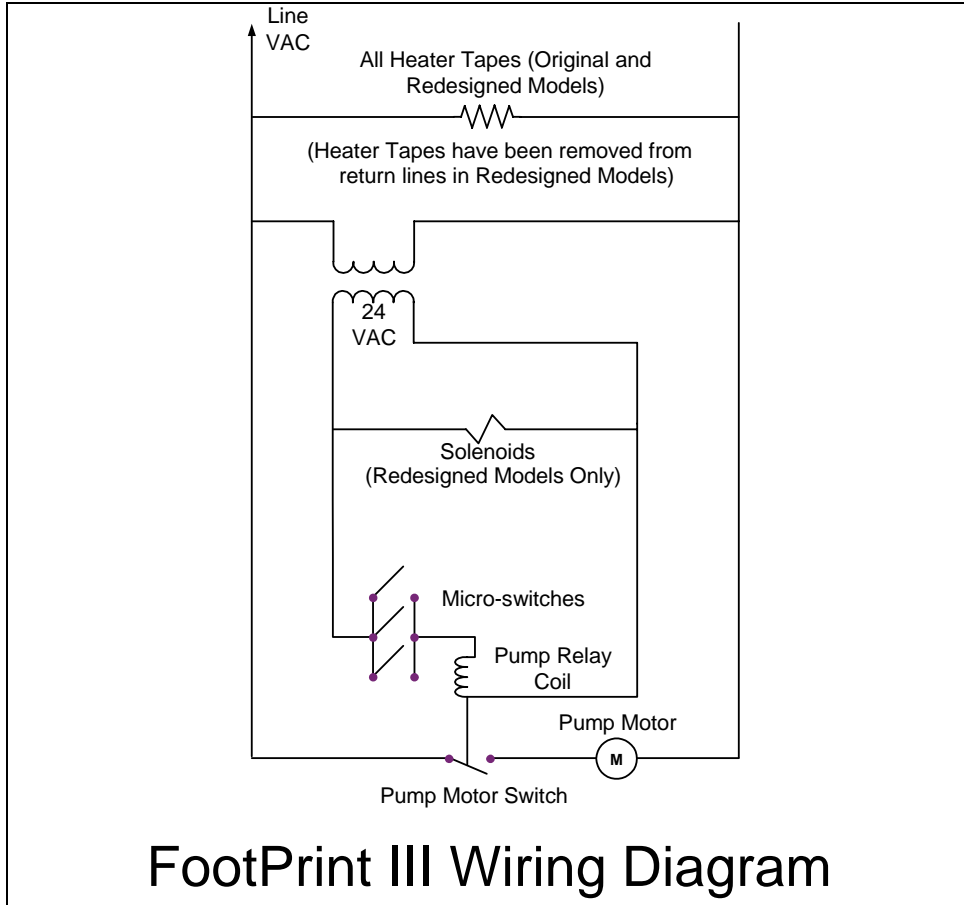

Operation of the redesigned FP-III system is the same as for the original design.

ORIGINAL VS REDESIGNED FP-III FILTRATION SYSTEM	
Original System	Redesigned System
Return lines and manifolds wrapped with silicone strip heaters and aluminum tape.	No heater strips or aluminum tape on return lines.
Filter base assembly connected to unit with a black, heated return hose beneath the filter.	Non-heated Teflon hose with a swivel joint connects the filter base assembly to the unit above the filter.
Filter base assembly equipped with swivel casters.	Filter base assembly has no casters.
Operator-removable filter base assembly. (Filter base assembly stop-locks in cabinet can be rotated to remove tray.)	Filter base assembly is not removable except by a qualified service technician. (Filter base assembly stop-locks fitted with a screw and nut to prevent filter removal.)
Oil/shortening remains in return lines when filter system is turned off.	Oil/shortening drains back to the filter pan when filter system is turned off, leaving no oil or shortening in return lines.
Return drain-manifolds are constructed with pipe nipples, elbows and other plumbing components.	Return drain manifolds are one-piece with an in-line solenoid valve to facilitate drain to filter pan.

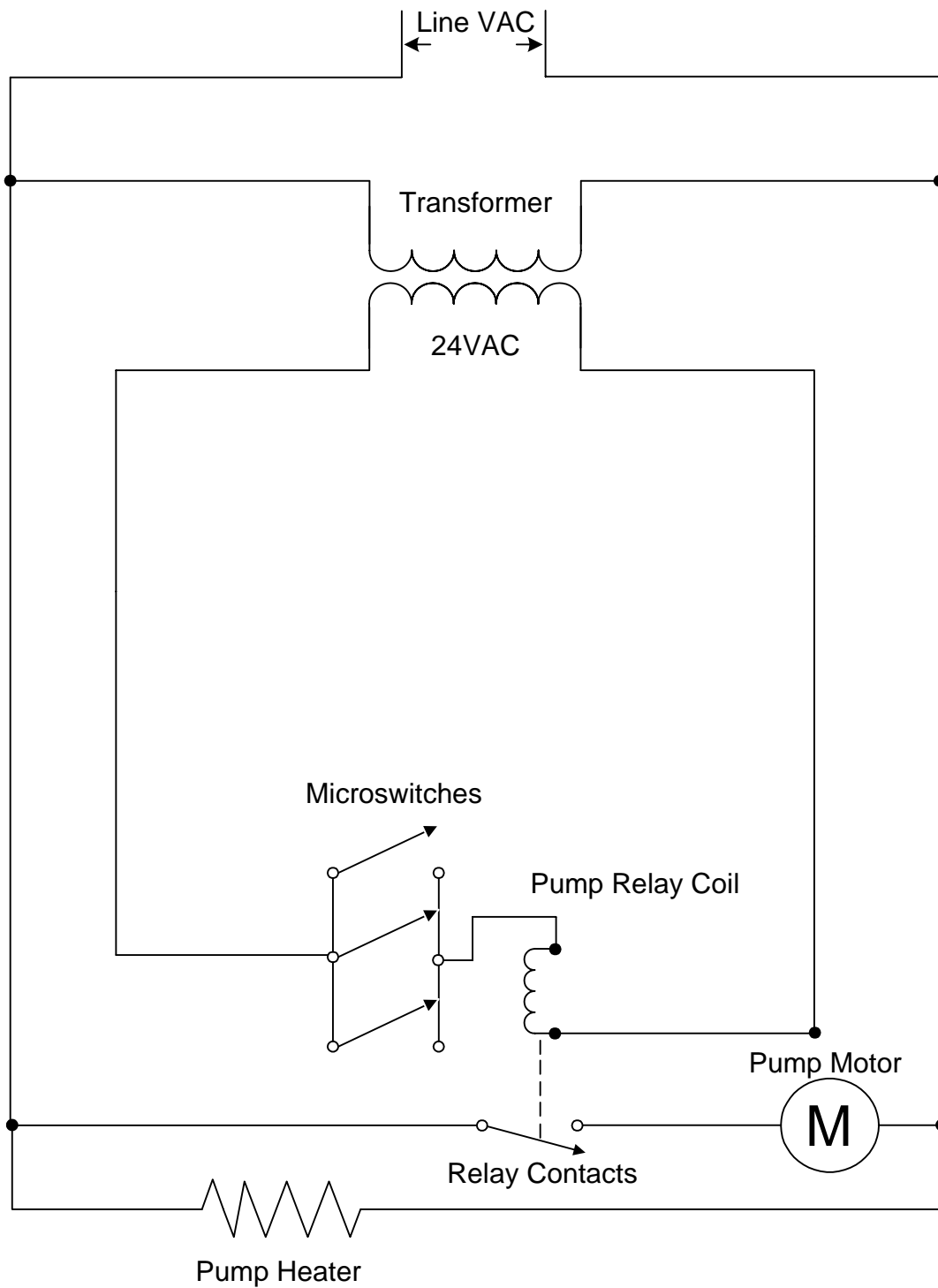

Filter Magic Simplified Wiring Diagram

1.11 Basket Lift Service Procedures

H14/H17/H22 Series fryers may optionally be equipped with automatic basket lifts to ensure uniform cooking times. Basket lifts will always come in pairs, although each operates independently.

All electric fryers are equipped with “modular” basket lifts.

A **modular basket lift** (illustrated below) consists of a toothed rod to which the basket lift arm is attached, a reversible-drive gear motor, and a pair of roller-activated microswitches. The gear motor engages the teeth in the rod, moving it up or down, depending upon the direction of rotation of the motor. Microswitches at the upper and lower limits of movement stop the motor when the basket is in the full up or full down position.

Timing circuitry in the controller initiates and stops basket lift operation depending upon the variables programmed by the operator. When the product button is pressed, the timing circuitry activates a coil in the basket lift relay to supply power to the lower microswitch. The microswitches stop the motor at the lift’s upper and lower travel limits and reverse the direction of current flow thus reversing the motor direction.

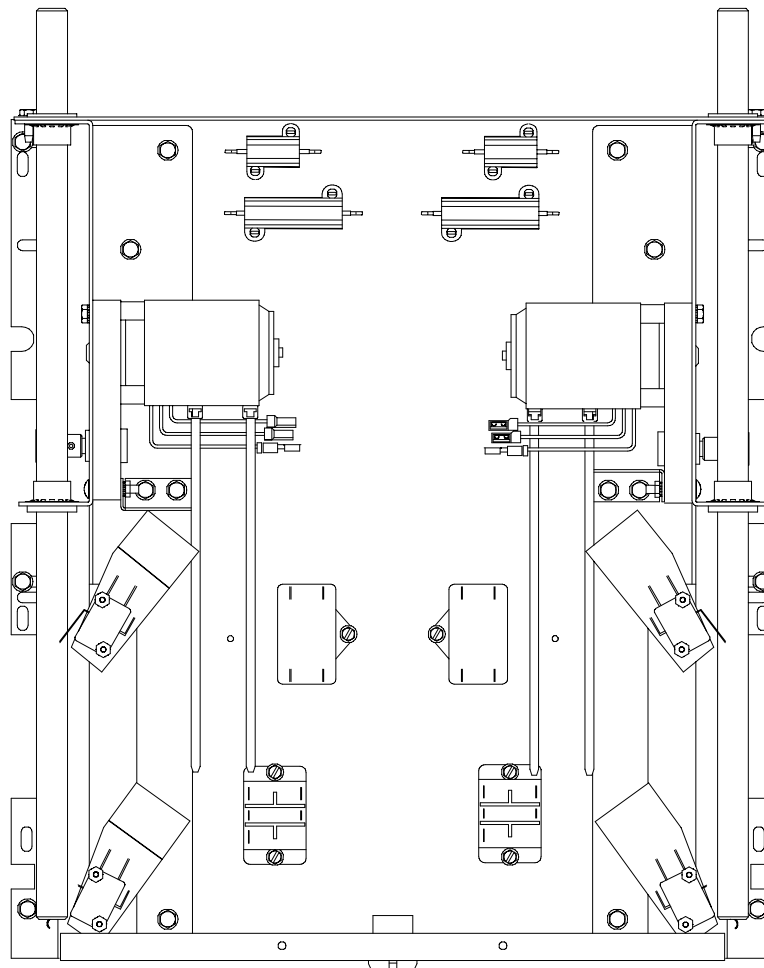

Modular Basket Lift Assembly (Typical)

Simplified Schematic

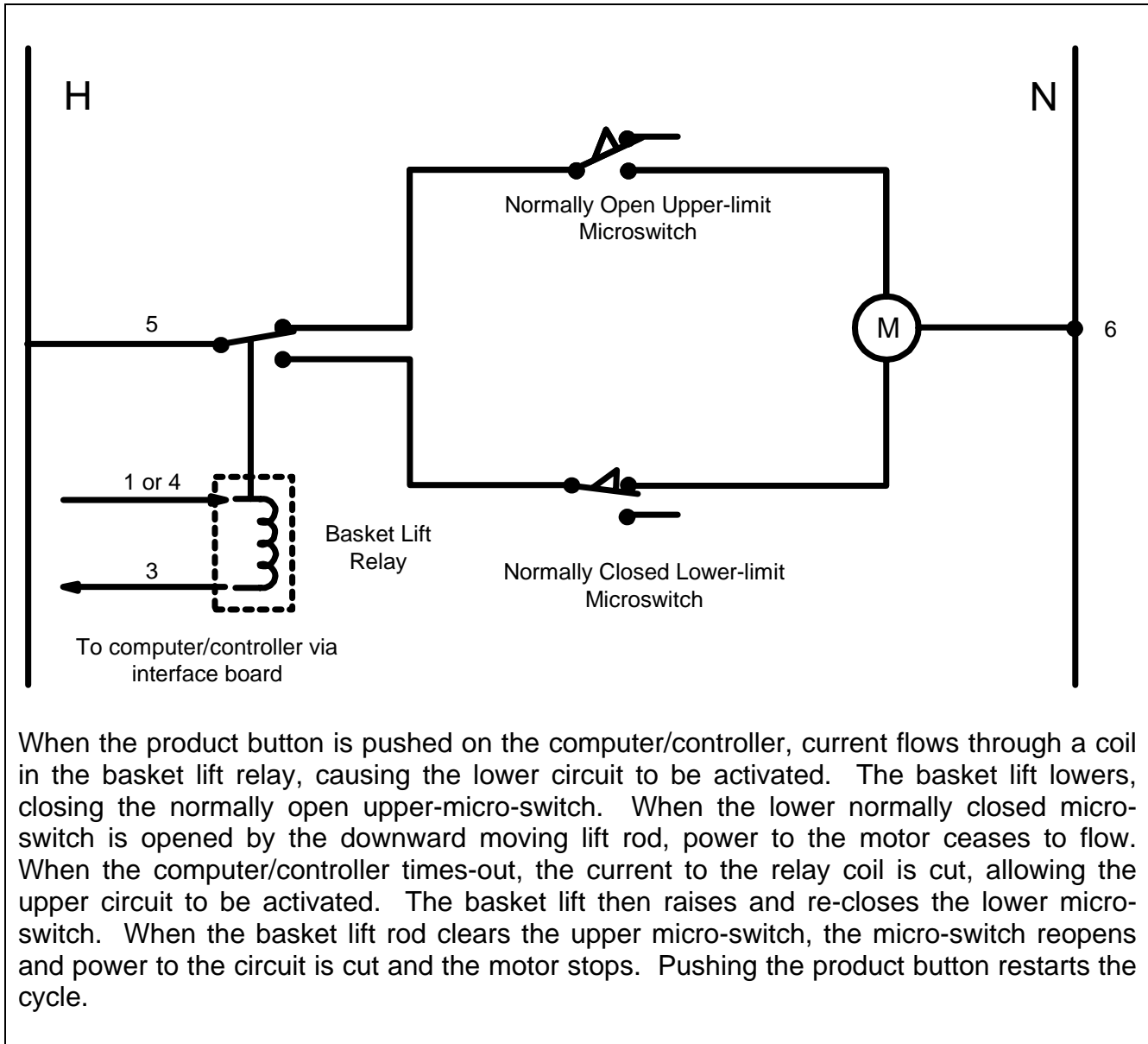

Problems with the modular basket lift design can be grouped into three categories:

- Binding/jamming problems
- Motor and gear problems
- Electronics problems

BINDING/JAMMING PROBLEMS

Noisy, jerky or erratic movement of the lifts is usually due to lack of lubrication of the rods and their bushings. Apply a light coat of Lubriplate[®] or similar lightweight white grease to the rod and bushings to correct the problem.

With the modular basket lift, another possible cause of binding is improper positioning of the motor, which prevents the gear from correctly engaging the teeth in the rod. To correct the problem, loosen the screws that hold the motor in place and move it forward or backward until the rod has just enough slack to be rotated slightly.

MOTOR AND GEAR PROBLEMS

With the modular basket lift, the most likely problem to be encountered in this category is erratic motion of the lift due to a worn drive gear. Failure to keep the lift rod and bushings properly lubricated will cause unnecessary wear of the gear. The problem is corrected by replacing the worn gear.

If the lift cycles correctly but fails to remain in the up position (i.e., goes up, but then slowly settles back down into the frypot), the problem is a failed motor brake. A failed motor brake cannot be repaired and requires replacement of the motor itself.

If power is reaching the motor but the motor fails to run, the motor is burned out and must be replaced.

ELECTRONICS PROBLEMS

Within this category are problems associated with the relays, microswitches, capacitors, resistors, interface board, wiring, and controls. The most common problem in this category is a lift that continuously travels up and down. This is usually caused by a microswitch that is out of adjustment.

Troubleshooting the electronics of a modular-type basket lift is simply a process of verifying current flow through the individual components up to and including the motor. Using a multimeter set to the 250 VAC range, check the connections on both sides of the component for the presence of the applied line voltage. The accompanying simplified wiring diagrams identify the components and wiring connection points.

1.12 Electric Interface Board Diagnostic Chart

The following diagram and charts provide ten quick system checks that can be performed using only a multimeter.

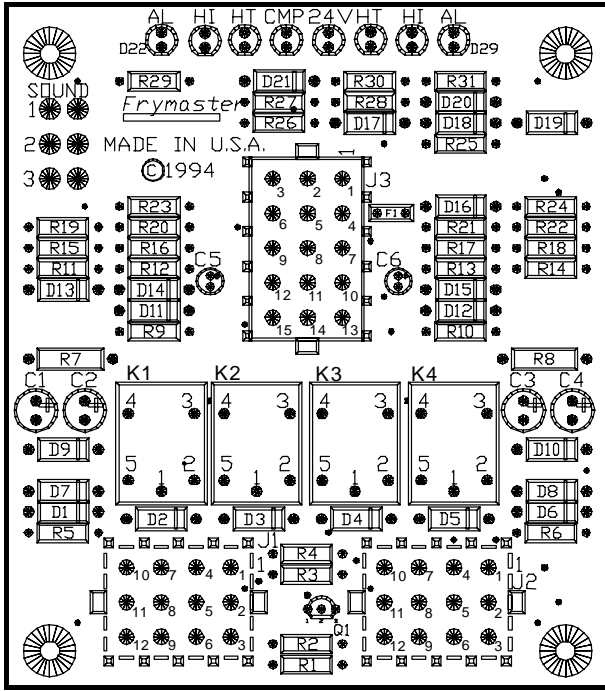

Note: The sealed relays are not replaceable. If a relay fails the interface board must be replaced.

Diagnostic LED Legend

CMP indicates power from 12V transformer
24 indicates power from 24V transformer
HI (RH) indicates output (closed) from right latch relay
HI (LH) indicates output (closed) from left latch relay
HT (RH) indicates output from right heat relay
HT (LH) indicates output from left heat relay
AL (RH) indicates output (open) from right latch relay
AL (LH) indicates output (open) from left latch relay

Meter Setting	Test	Pin	Pin	Results
12 VAC Power	50 VAC Scale	1 of J2	3 of J2	12-16 VAC
24 VAC Power	50 VAC Scale	2 of J2	Chassis	24-30 VAC
*Probe Resistance (RH)	R X 1000 OHMS	11 of J2	12 of J2	See Chart
*Probe Resistance (LH)	R X 1000 OHMS	3 of J1	2 of J1	See Chart
Hi-Limit Continuity (RH)	R X 1 OHMS	7 of J2	4 of J2	0 - OHMS
Hi-Limit Continuity (LH)	R X 1 OHMS	4 of J1	7 of J1	0 - OHMS
Latch Contactor Coil (RH)	R X 1 OHMS	8 of J2	Chassis	3-10 OHMS
Latch Contactor Coil (LH)	R X 1 OHMS	5 of J1	Chassis	3-10 OHMS
Heat Contactor Coil (RH)	R X 1 OHMS	9 of J2	Chassis	18-25 OHMS
Heat Contactor Coil (LH)	R X 1 OHMS	6 of J1	Chassis	18-25 OHMS

***Disconnect 15-Pin harness from the computer/controller before testing the probe circuit.**

1.13 Simplified Wiring Diagrams, Common Electric

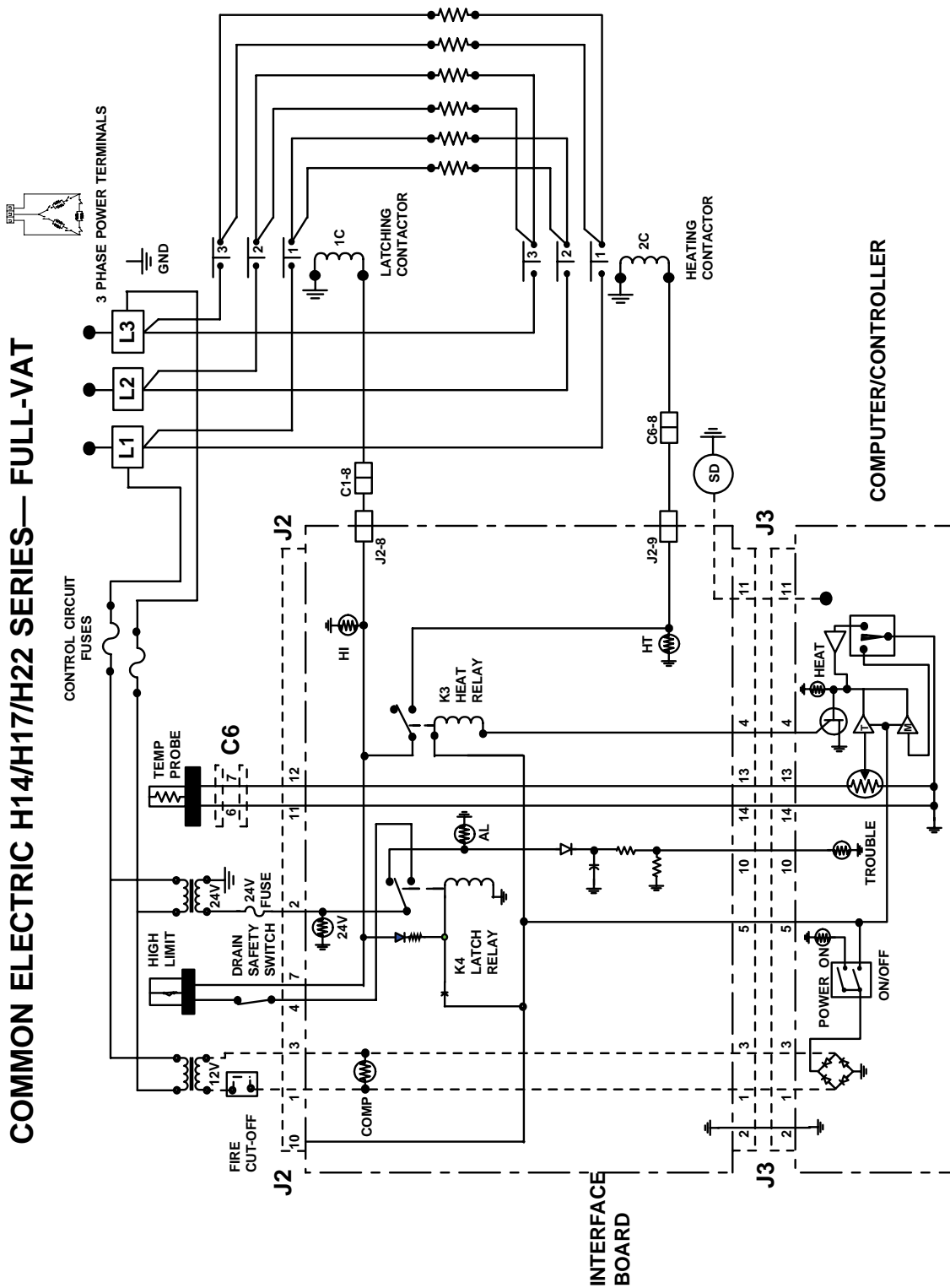

COMMON ELECTRIC H14/H17/H22 SERIES— DUAL-VAT

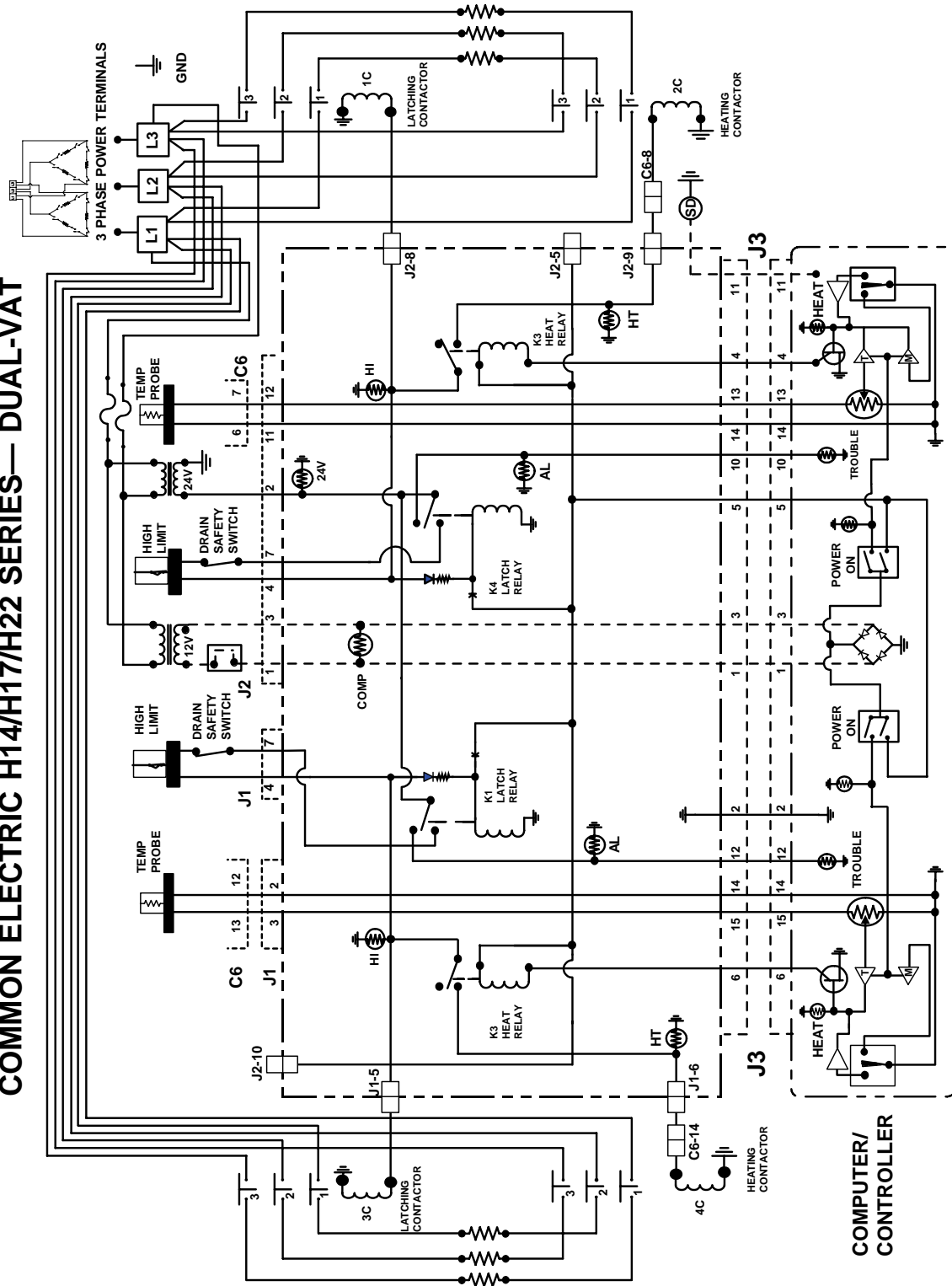

COMMON ELECTRIC H14/H17/H22 SERIES- TRIAC— FULL-VAT

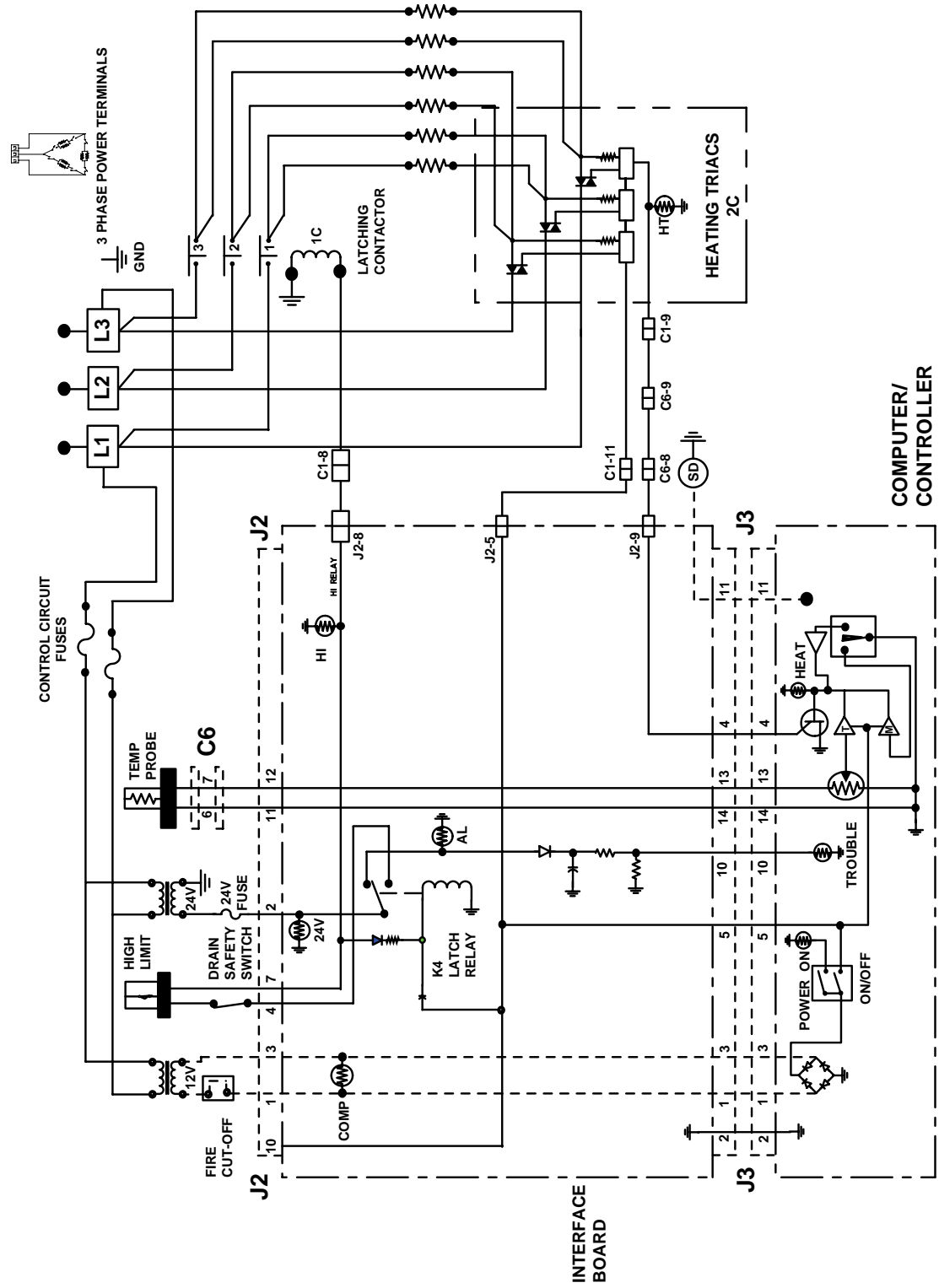

COMMON ELECTRIC H14/H17/H22 SERIES— FULL-VAT— EXPORT WYE

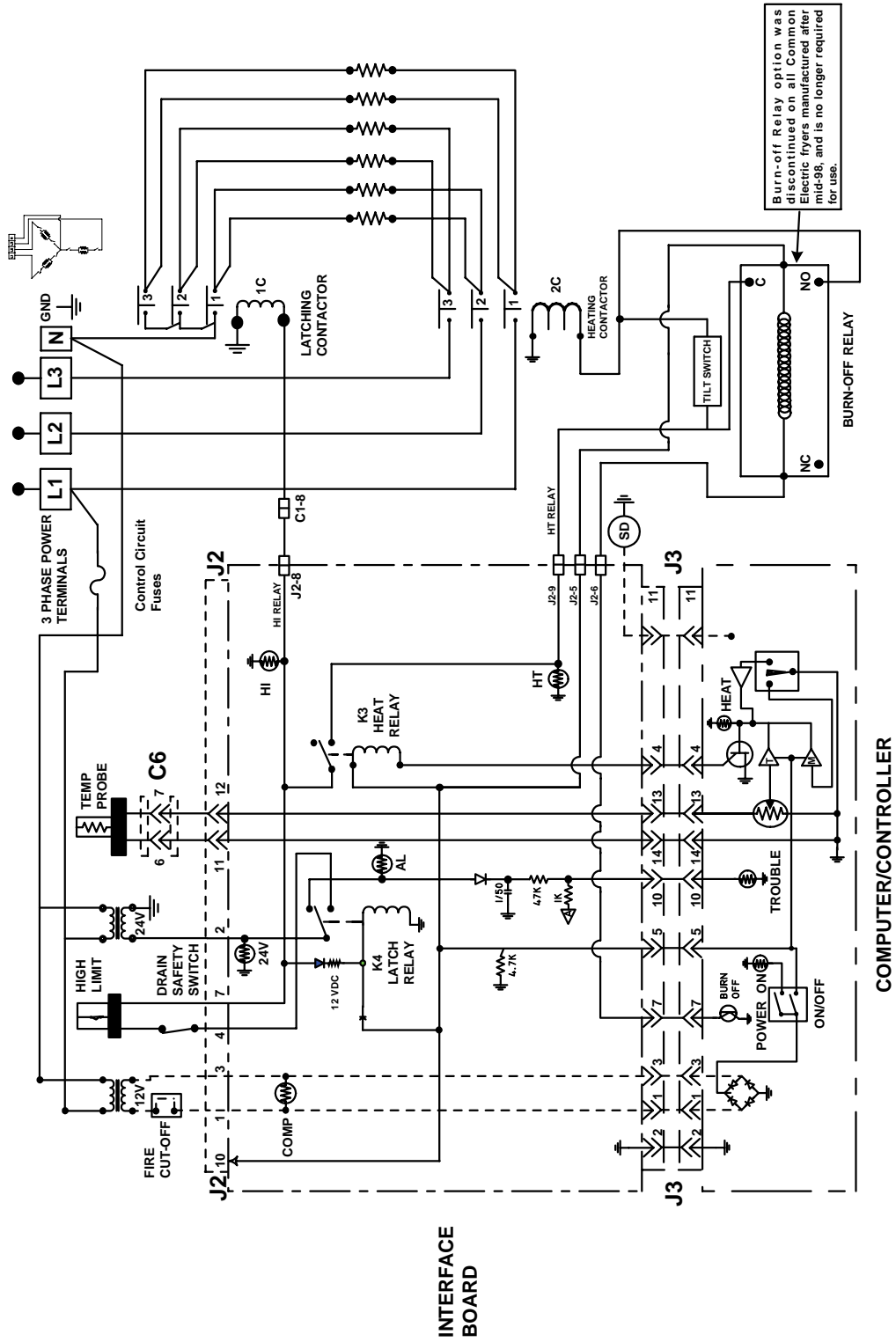

COMMON ELECTRIC McDONALD'S H14 SERIES— DUAL-VAT— EXPORT WYE

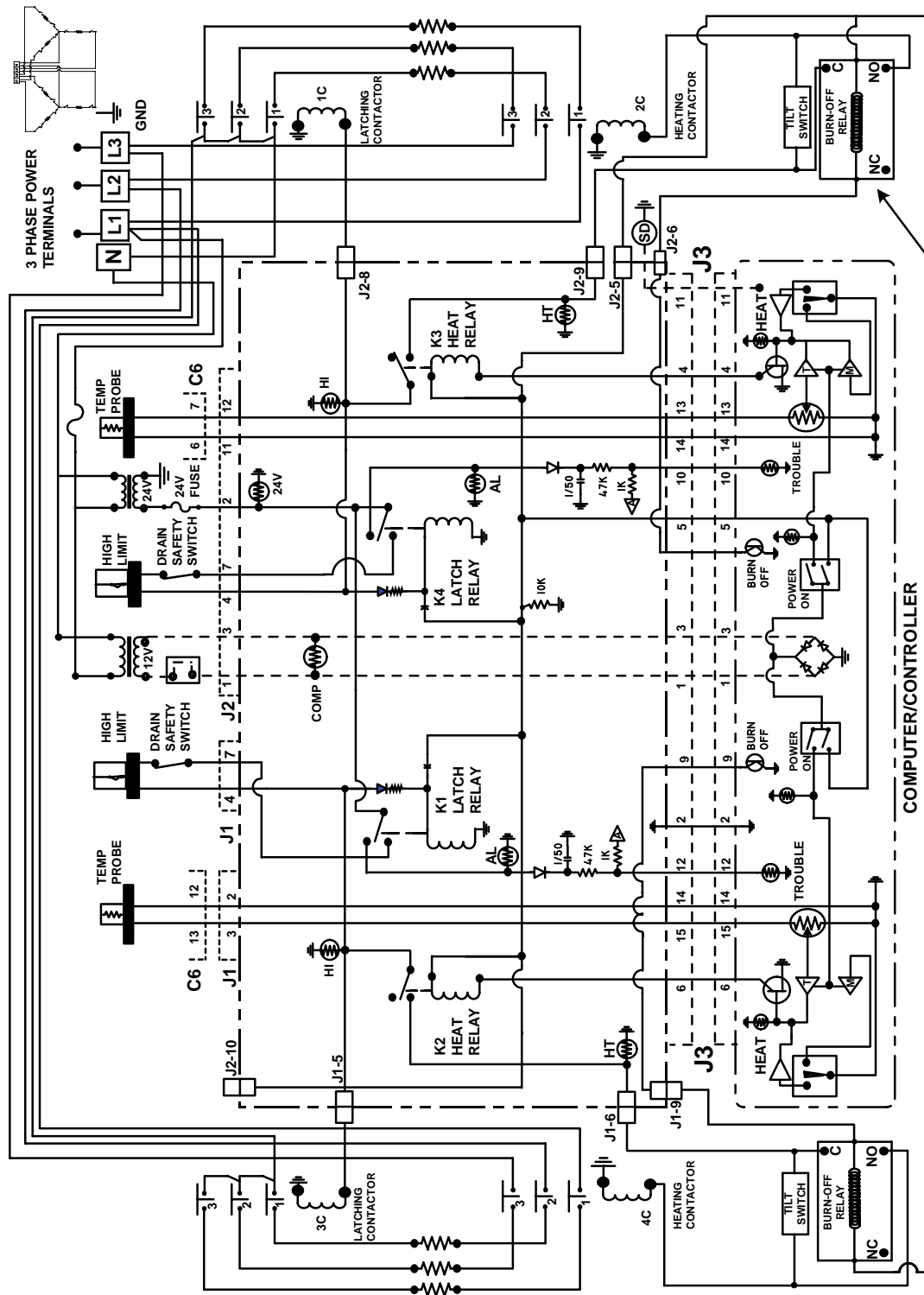

Burn-off Relay option was discontinued on all Common Electric fryers manufactured after mid-88, and is no longer required for use.

FPH114/117/122 CE Wiring Diagram

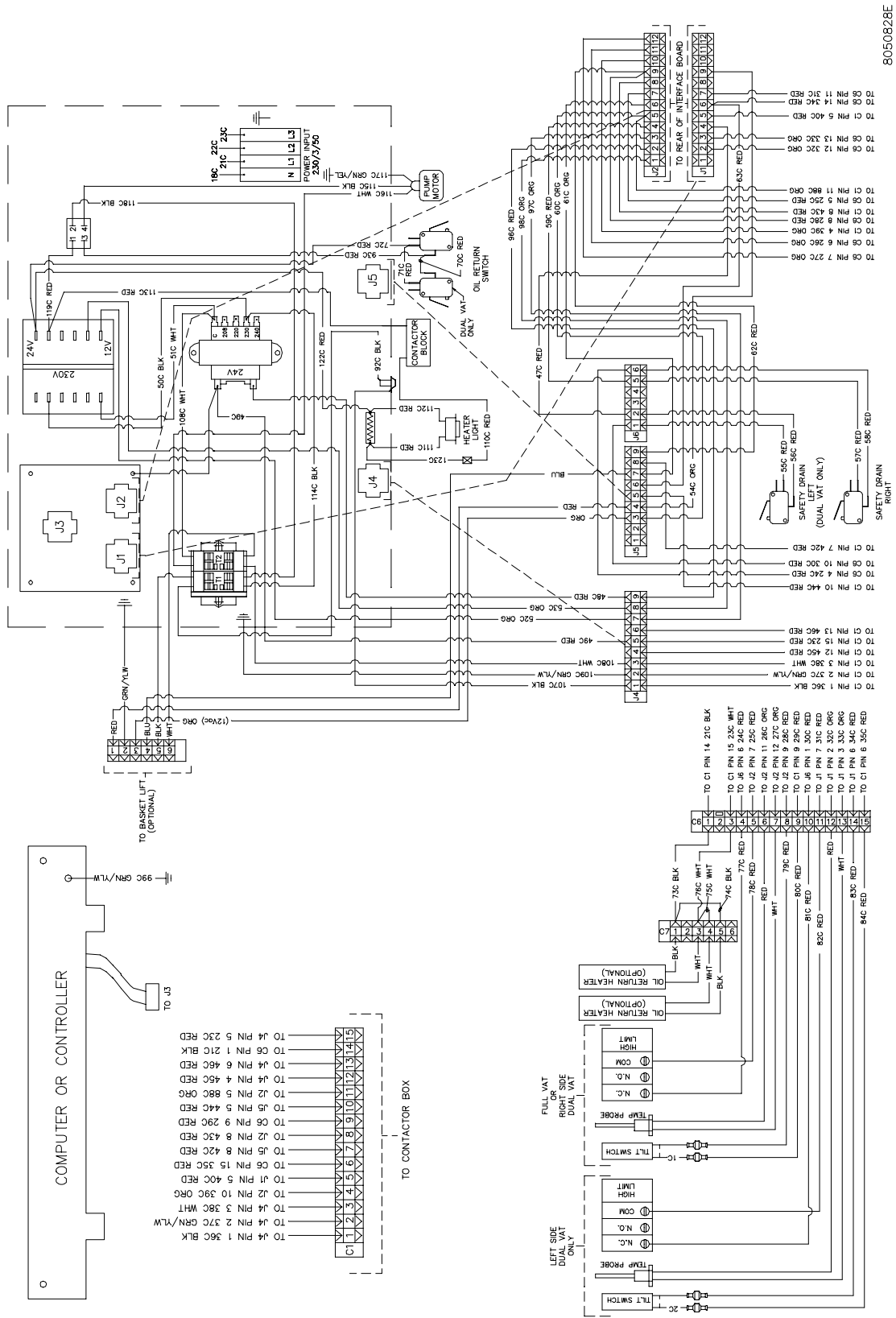

Delta 480V With FootPrint/Filter Magic II Wiring Diagram

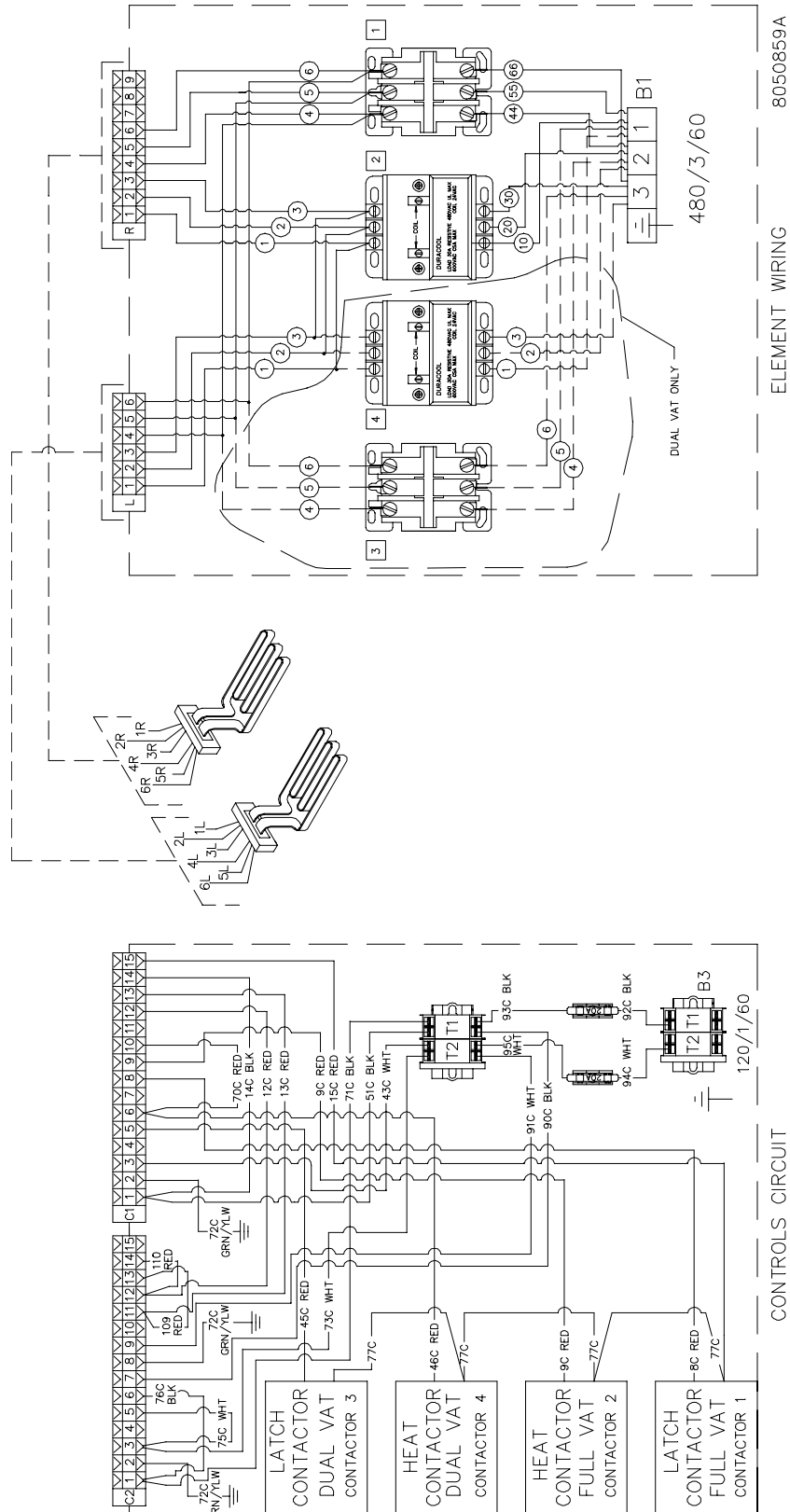

1.15 Wiring Diagrams, Basket Lifts

Modular Basket Lift, 100—120V w-Relay Wiring Diagram

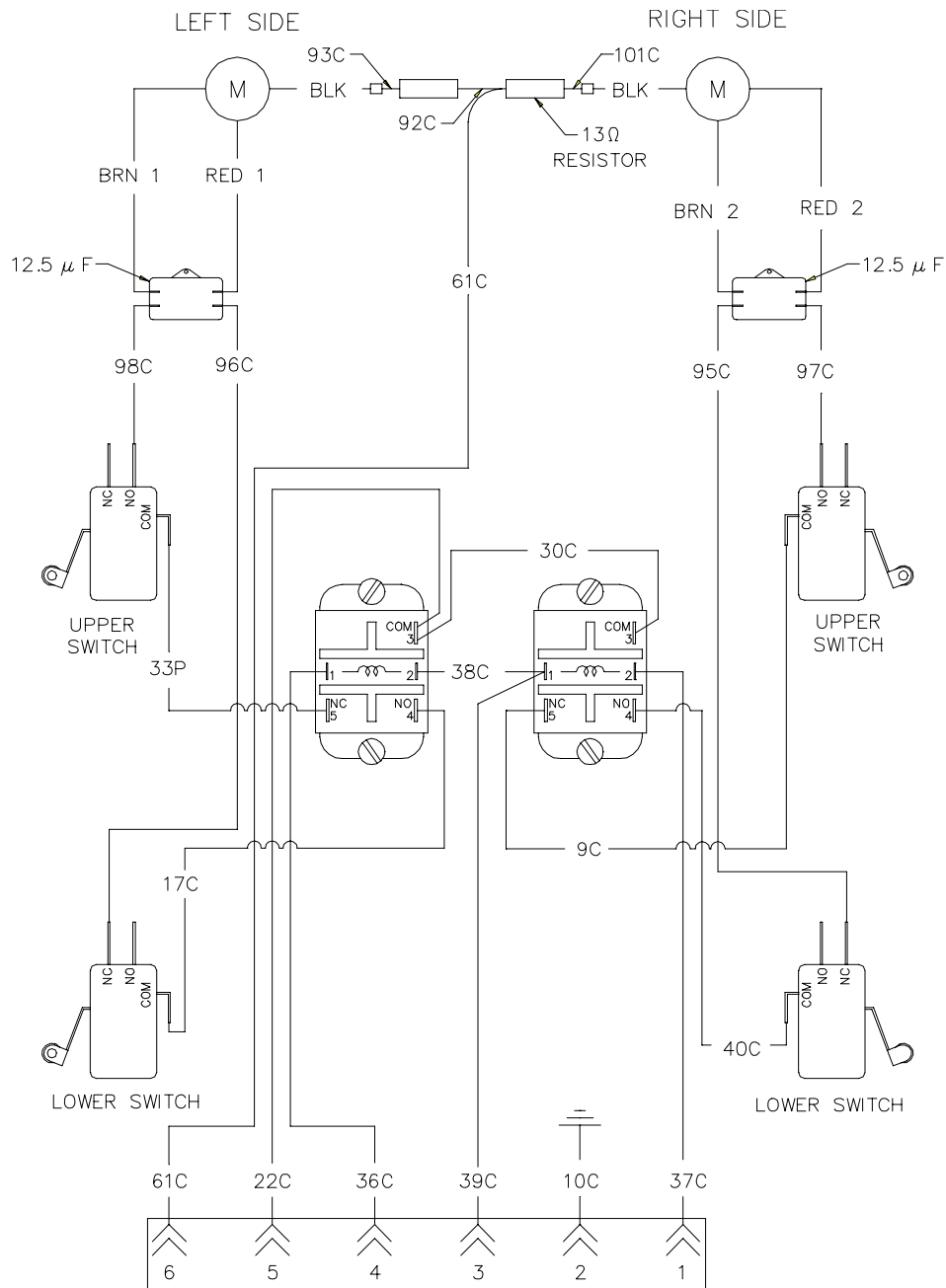

REFERENCES TO LEFT & RIGHT ARE FROM THE REAR OF THE FRYER

8050555D

1.15 Wiring Diagrams, Basket Lifts (cont.)

Modular Basket Lift, 208—250V w-Relay Wiring Diagram

NOTE: Some units will have four 50ohm resistors rather than two 100ohm resistors.

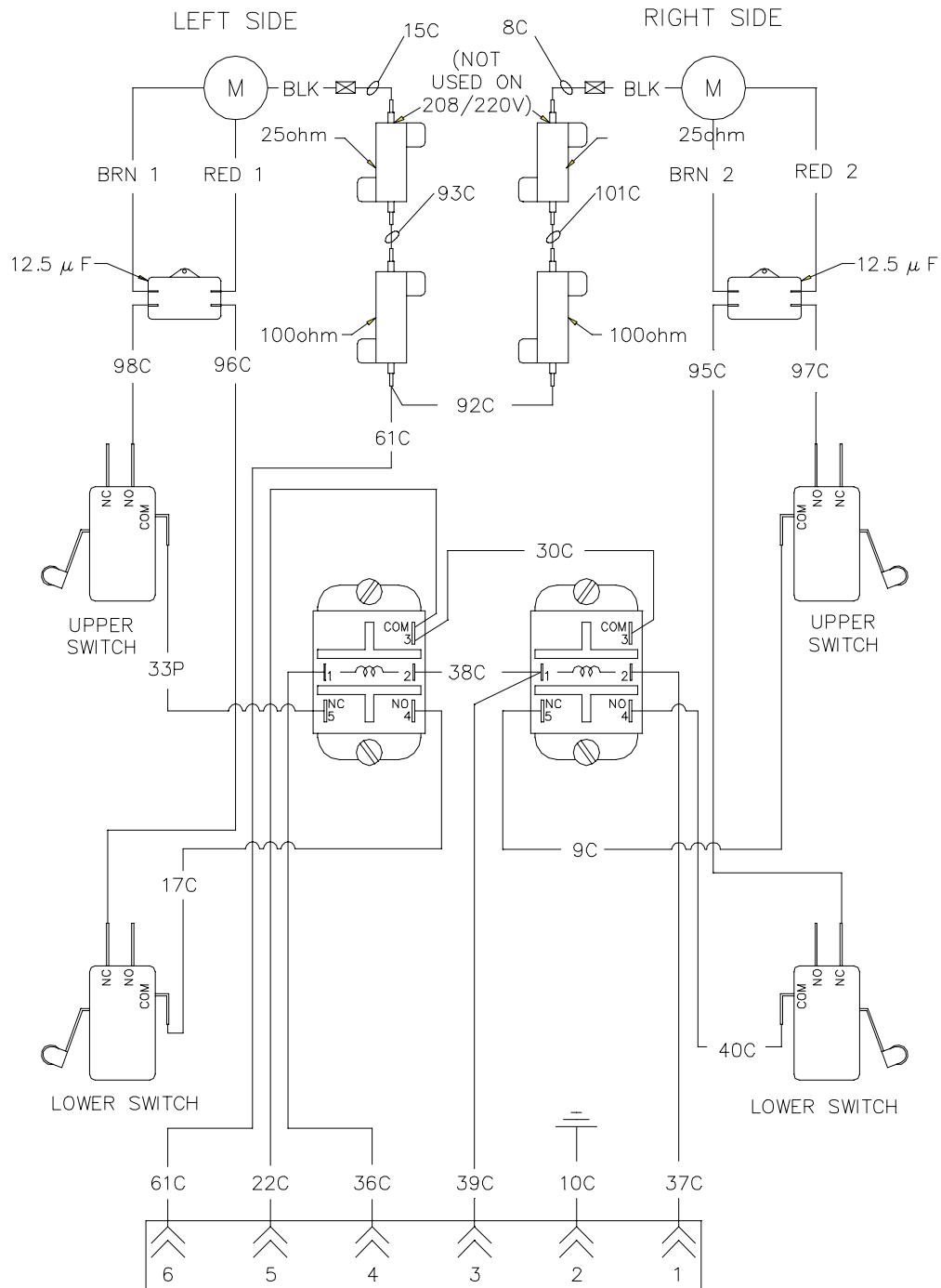

REFERENCES TO LEFT & RIGHT ARE
FROM THE REAR OF THE FRYER

8050888C

1.16 Wiring Diagrams, Filtration Systems

Filter Magic II (Prior to October 98)

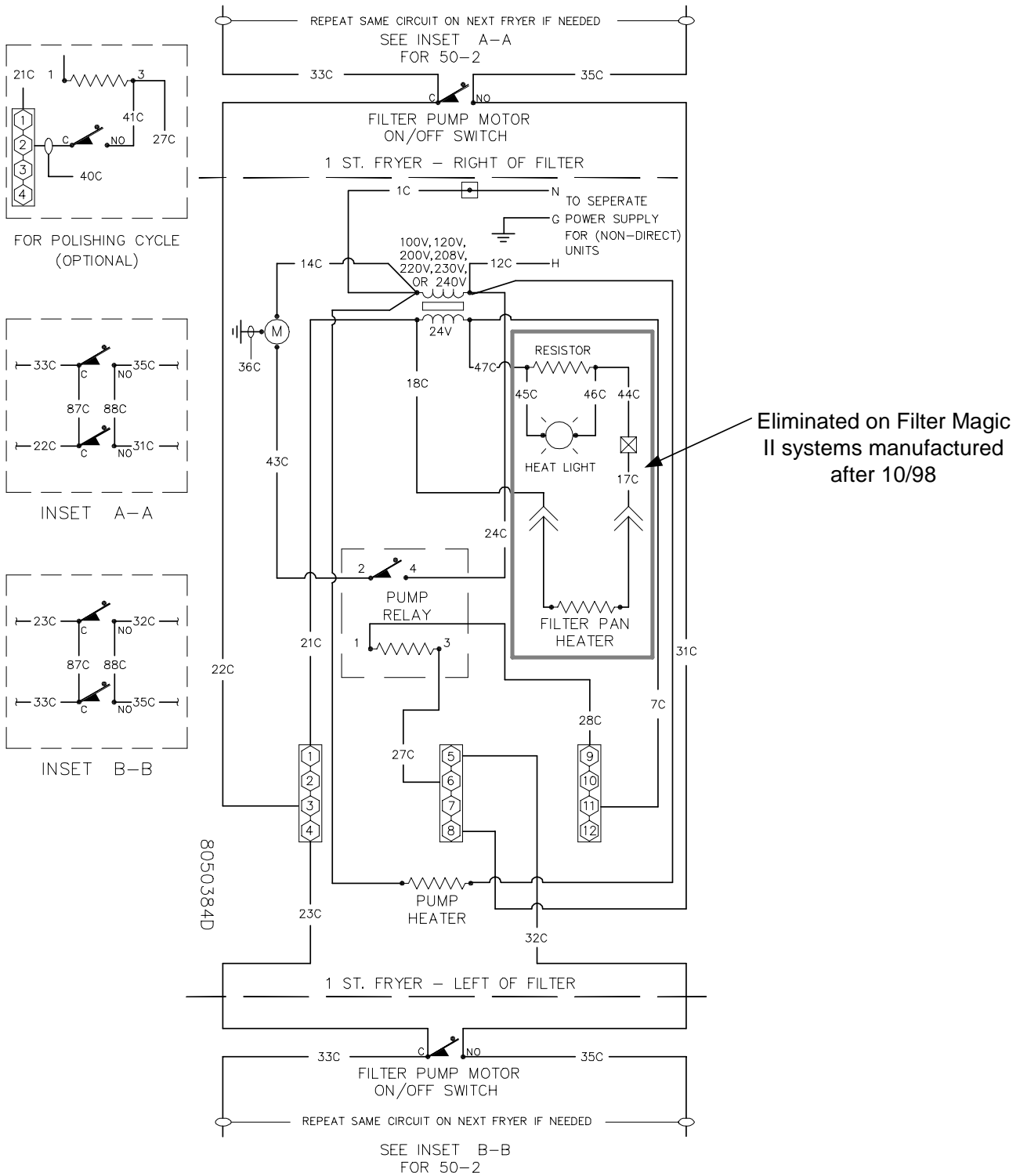

Filter Magic II (October 98 and later)

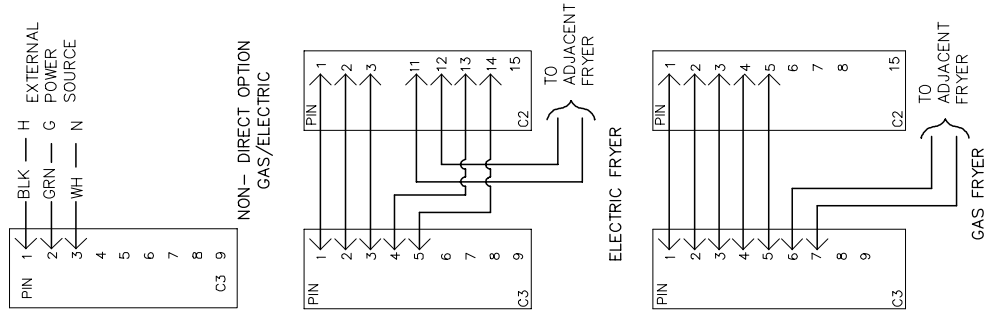

8050503E

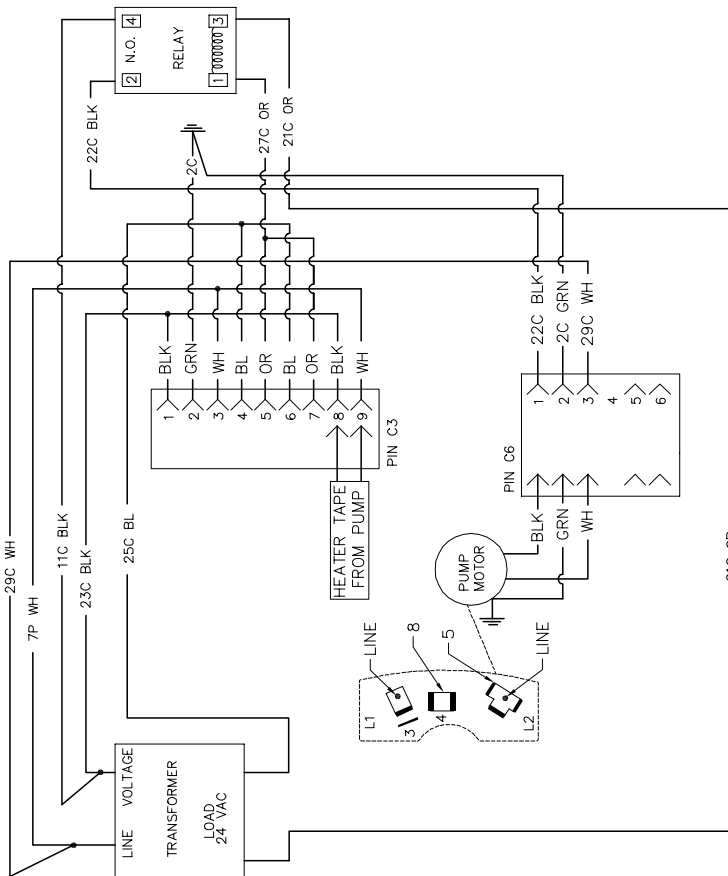

Footprint III, Early Configuration.

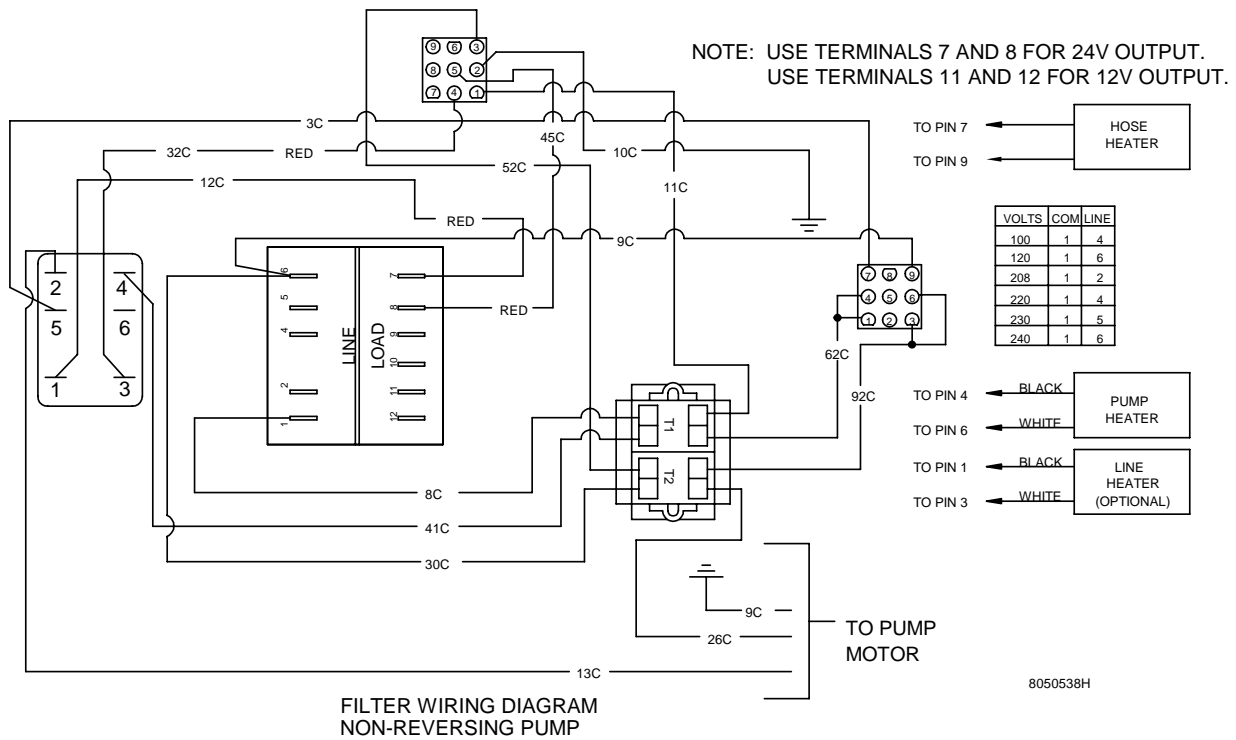

Footprint III, Late Configuration

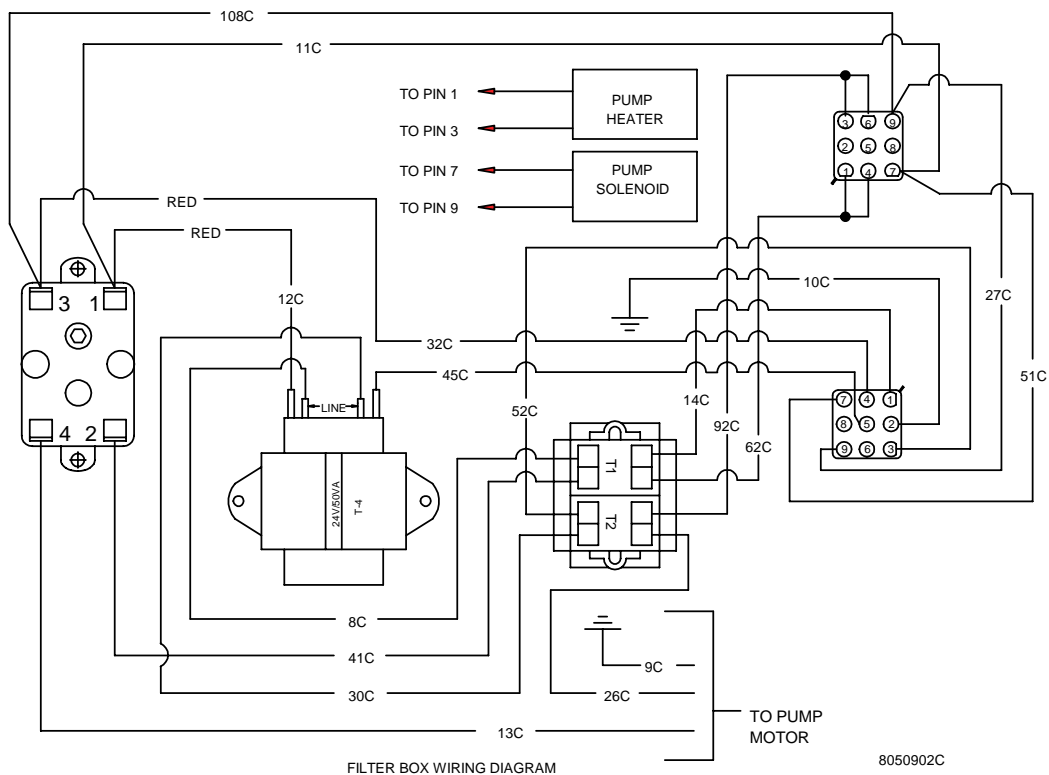

H14/H17/H22 SERIES ELECTRIC FRYERS

CHAPTER 2: PARTS LIST

2.1 Accessories

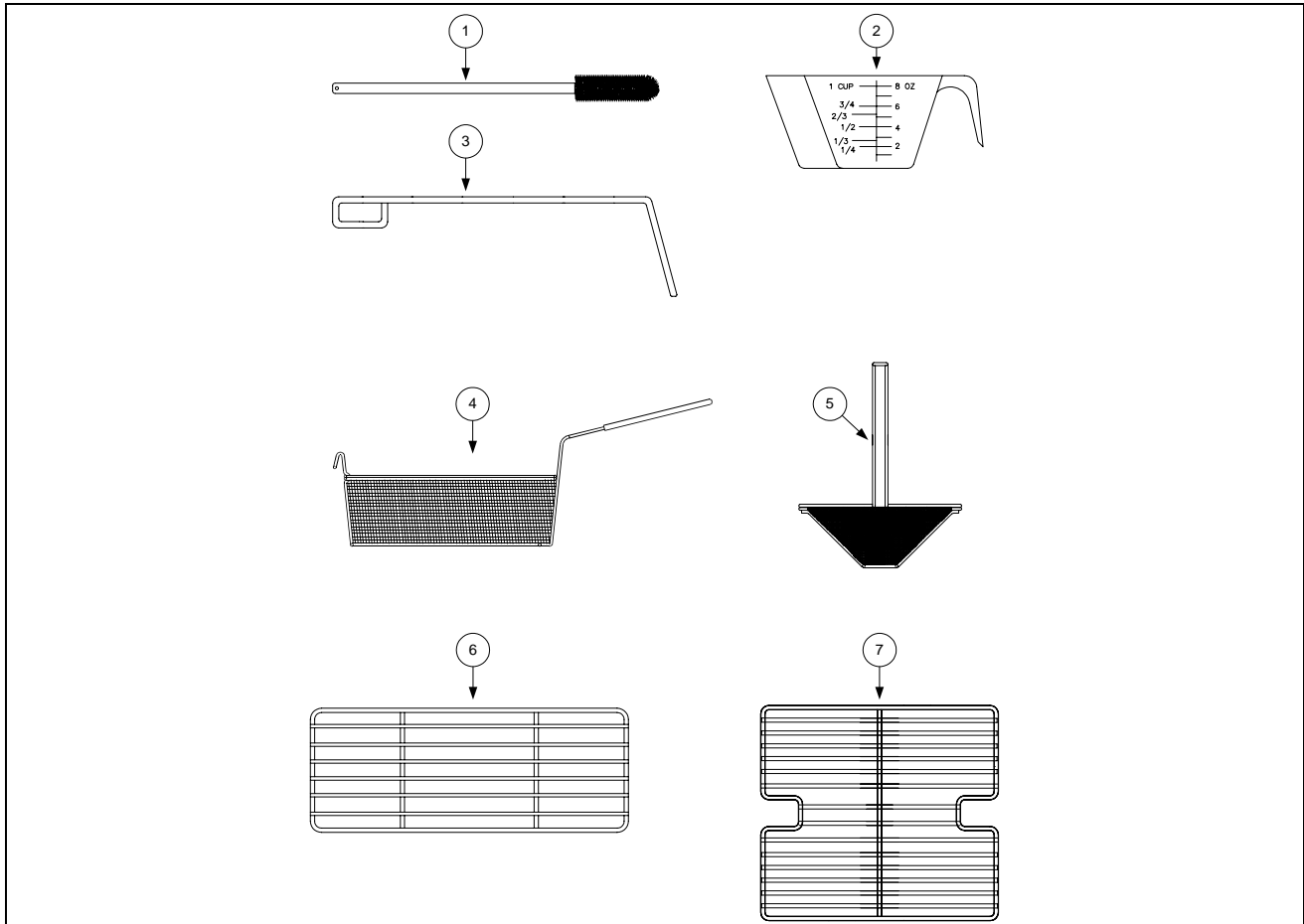

ITEM	PART #	COMPONENT
1	803-0209	Brush, FV/DV Frypot
2	803-0046	Cup, Measuring, Plastic, #1040
3	803-0197	Fryer Friend 27-inch (Clean-out Rod)
4	803-0099	Basket, Full-vat
*	803-0271	Basket, Dual-vat
5	803-0113	Sediment Tray, Full-vat
*	803-0122	Sediment Tray, Dual-vat, Left
*	803-0123	Sediment Tray, Dual-vat, Right
6	803-0106	Rack, Electric Dual-Vat Basket Support
7	803-0132	Rack, H50 Full-Vat With Probe Guard Basket
*	803-0002	Carton, Filter Powder
*	803-0170	Filter Pack– 100 Sheets
*	806-3068	Cover, Full Vat Frypot
*	806-3071	Cover, Dual Vat Frypot

* Not illustrated.

2.2 Basket Lift Assemblies and Component Parts

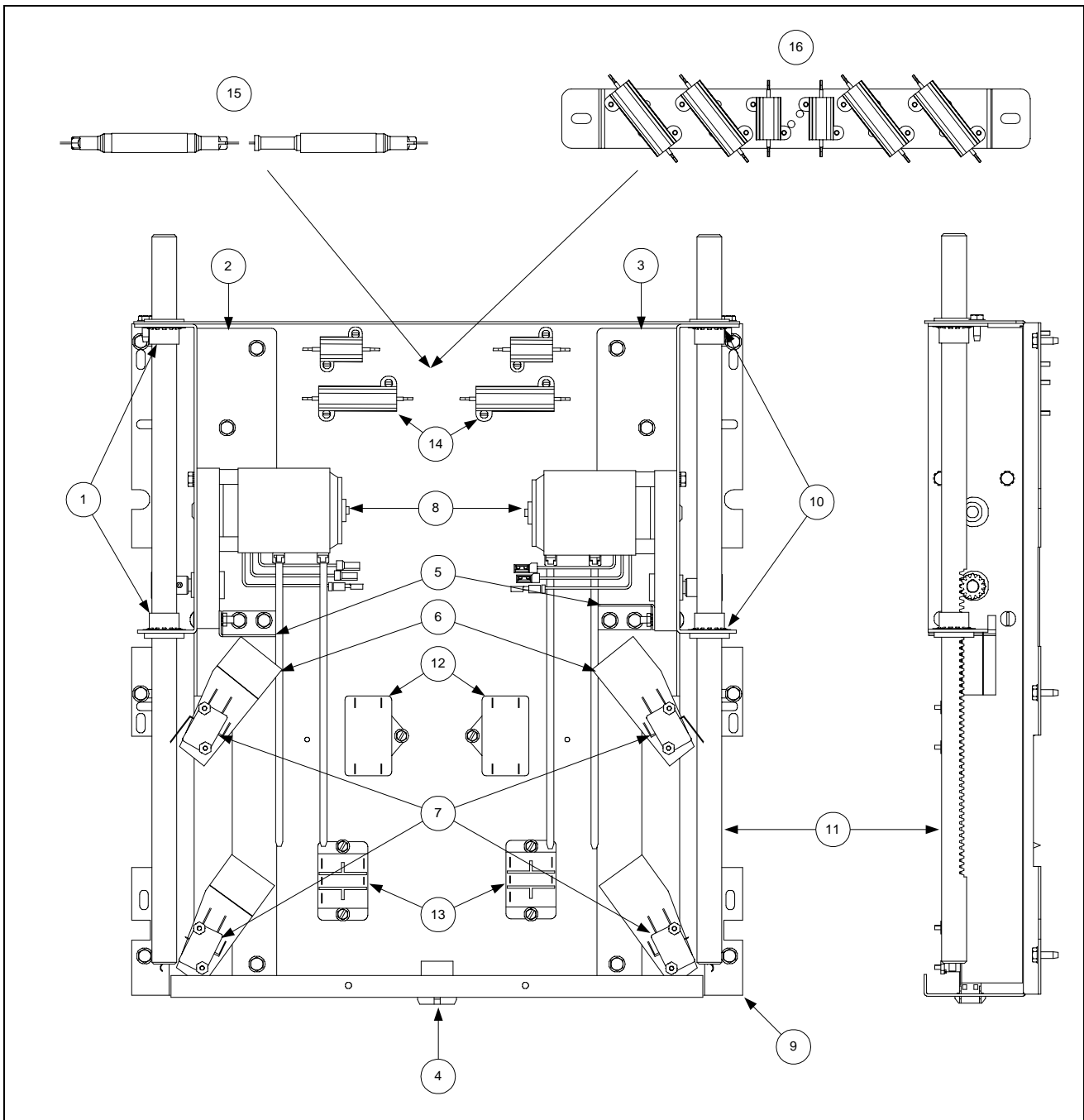

ITEM	PART #	COMPONENT
		Common Components
1	813-0035	Bushing, Bronze, .640-inch ID
2	901-8499	Chassis, Modular Basket Lift, Left
3	902-8499	Chassis, Modular Basket Lift, Right
4	807-0158	Connector, 6-Pin Female, Panel Mount
5	900-5529	Gusset, Modular Basket Lift Motor
6	812-0442	Insulation, Microswitch
7	807-2572	Microswitch
8	806-5964SP	Motor Assembly, Modular Basket Lift
9	200-2942	Mount, MBL (for old mount w/6-pin plug use 900-7655)
10	809-0082	Ring, Retaining – Truarc
11	810-1012	Rod, Modular Basket Lift
*	823-2704	Left Basket Lift Arm
*	823-2705	Right Basket Lift Arm
12	807-2133	Capacitor, 12.5 μ Farad, 250VAC Motor
		Resistors
13	807-1683	Relay, 12V (All Basket Lifts w/Relays)
14	806-9185	Resistor Assembly, Modular Basket Lift (used in 806-8532SP)
15	806-8530	Resistor Assembly, Modular Basket Lift (used in 806-8531SP)
16		Resistor Assembly, Modular Basket Lift (see NOTE below)
	106-2770	200-220V (used in 806-8086SP and 806-8685SP)
	106-2771	230-250V (used in 806-8087SP and 806-8686SP)
		Wire Assemblies
	WIR00482	For 106-1807SP (for 6-pin MBL assembly 806-8531SP, use WIR0073SP)
	WIR0292	For 806-8532SP
	WIR0166	For 806-8086SP & 806-8087SP
	806-8555SP	For 6-pin assemblies 806-8685SP & 806-8686SP
	106-1804SP	For 12-pin assemblies 106-1809SP & 106-1810SP
		Complete Assemblies
	106-1807SP	100/120V w/o Relay (for 6-pin assembly, use 806-8531SP)
	106-1808SP	100/120V w/Relay (for 6-pin assembly, use 806-8532SP)
	106-1809SP	200/208/220V w/o Relay (for 6-pin assembly, use 806-8685SP)
	106-1805SP	200/208/220V w/Relay (for 6-pin assembly, use 806-8086SP)
	106-1810SP	230/240/250V w/o Relay (for 6-pin assembly, use 806-8686SP)
	106-1806SP	230/240/250V w/Relay (for 6-pin assembly, use 806-8087SP)

* Not illustrated.

NOTE: Item 16 replaces all previous resistors and resistor assemblies used in 200-250V modular basket lifts.

2.3 Cabinet Assemblies and Component Parts

2.3.1 H114/117/122 Cabinet Assembly, Single FootPrint and Non-Filter

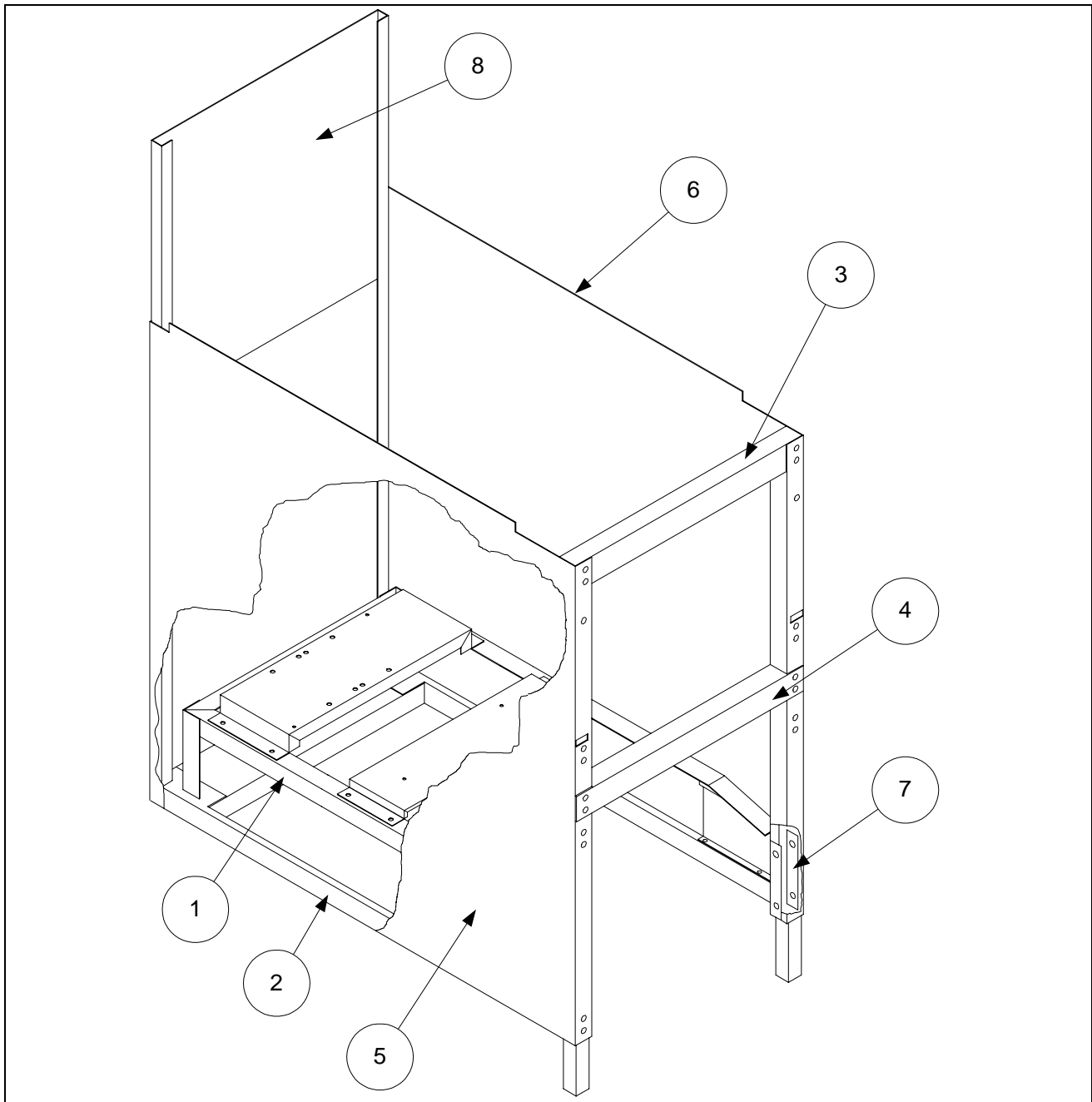

ITEM	PART #	COMPONENT
1	806-4910SP	Rail Assembly, Single FootPrint
*	200-0129	Rail, Top Front Single Common Electric N/F
2	806-4897SP	Base, Single FootPrint
*	806-7003SP	Base Assembly, Single Common Electric, N/F
3	900-4393SP	Brace, Top, Single FootPrint
4	900-4391SP	Brace, Cabinet Front
*	900-2733	Brace, Contactor Box, Front, N/F
*	900-2734	Brace, Support Contactor Box, Common Electric, N/F
*	200-0130	Brace, Rear Horizontal, Common Electric, N/F
*	201-0137	Upright- rear enclosure, Common Electric, N/F
*	202-0137	Upright- rear enclosure, Common Electric, N/F
5		Side, Cabinet – Left Side
	911-9314	Stainless Steel
	901-9314	Enameled Steel
6		Side, Cabinet – Right Side
	912-9314	Stainless Steel
	902-9314	Enameled Steel
*	910-2456SP	Cabinet Side, Common Electric N/F
7	900-1621	Plate, Rail Mount
8	910-2912	Back, Upper Cabinet, Single FootPrint
*	900-5204	Back, Cabinet, 22kW Single FP
*	900-4412	Bracket, Component, 22kW Single FP
*	900-2717SP	Back, Upper Cabinet, Common Electric, N/F
*	900-5141	Back, Center Cabinet, MH114
*	900-8449	Back, Lower Cabinet with U-shaped Cutout
*	200-4581	Back, Lower Cabinet without U-shaped Cutout
*	910-7925	Leg, Cabinet, Front Filter
*	900-9585	Heat Shield, Wire, Common Electric
*	826-1374	Screw, #10-1/2 Hex Head (Pkg. of 25)
*	826-1389	Screw, ¼-20 x ¾ Hex Head (Pkg. of 10)
*	826-1334	Bolt, ¼-20 X 1 ¼ Hex Head (Pkg. of 5)
*	826-1368	Nut, Flange ¼-20 Serrated (Pkg. of 10)
*	809-0070	Nut, Hex ¼ x 20 SS
*	809-0191	Washer, Lock, ¼-inch

* Not illustrated.

2.3.2 H114/117/122 Cabinet Assembly, Battered Option—Filter Ready

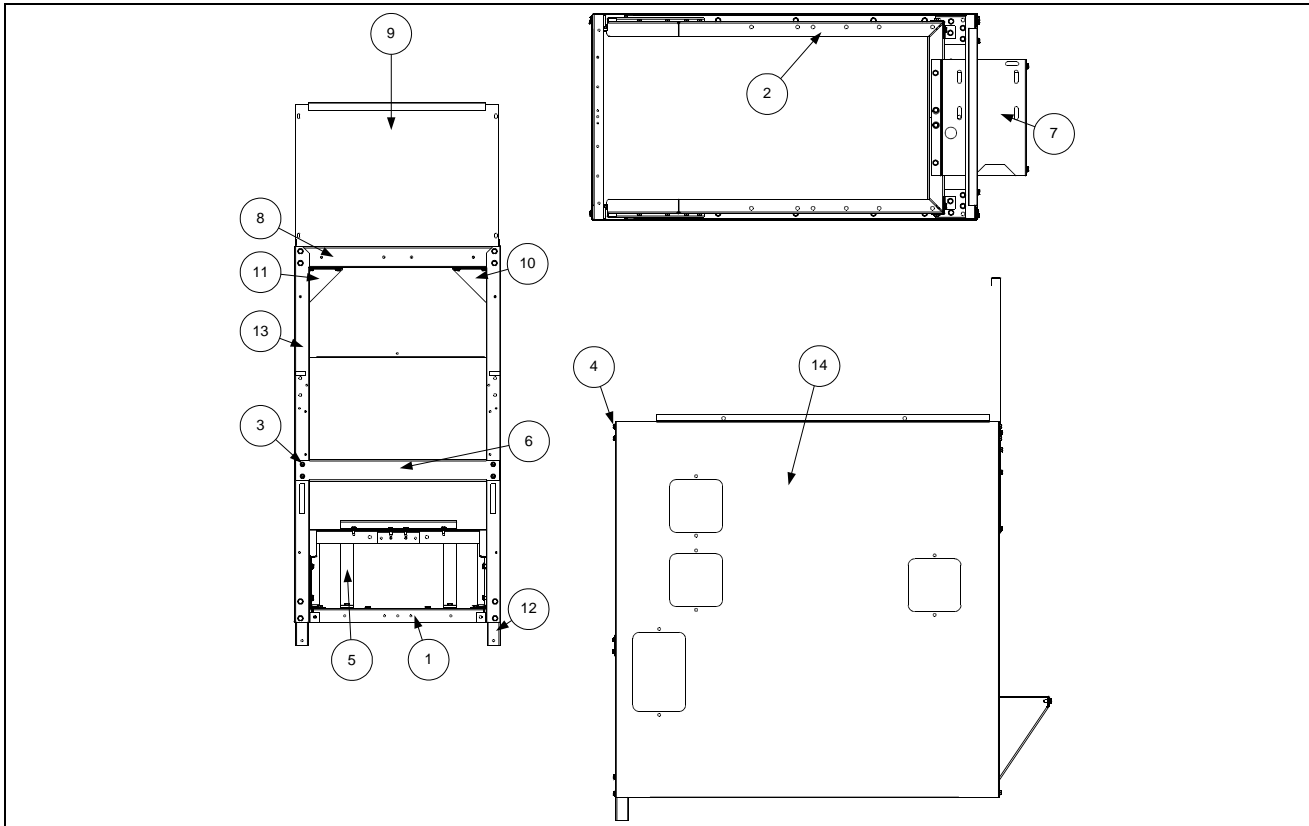

ITEM	PART #	COMPONENT
1	806-4897	Base, Single FP
2	806-5317	Filter Rail Assembly, Single FP
3	809-0361	Screw, 8 x 1/2 Hex
4	809-0412	Screw, #10-1/2 Hex
5	900-1786	Motor Mount, Cantilever Bracket
6	900-4391	Brace, Cabinet Front
7	900-4551	Motor Mount, Single FootPrint
8	900-4813	Brace, Cabinet Top Single
9	900-7448	Back, Top, FPH 50
10	901-1405	Gusset, Cabinet FP-TCF Left
11	902-1405	Gusset, Cabinet FP-TCF Right
12	910-8673	Leg, Front Filter w/Swivel Caster
13		Side, Cabinet, Left
	911-9324	Side, Stainless Steel
	901-9324	Side, Cold Rolled Steel
14		Side, Cabinet, Right
	912-9324	Side, Stainless Steel
	902-9324	Side, Cold Rolled Steel
*	910-0889	Cover, 4" x 4" S/S (for enameled steel, use 900-0889)
*	910-0890	Cover, 4" x 6" S/S (for enameled steel, use 900-0890)
*	809-0359	Screw, #8 x 1/4" Hex Washer Head

* Not illustrated.

2.3.3 Filter Magic Under-Counter Cabinetry (after 8/2000)

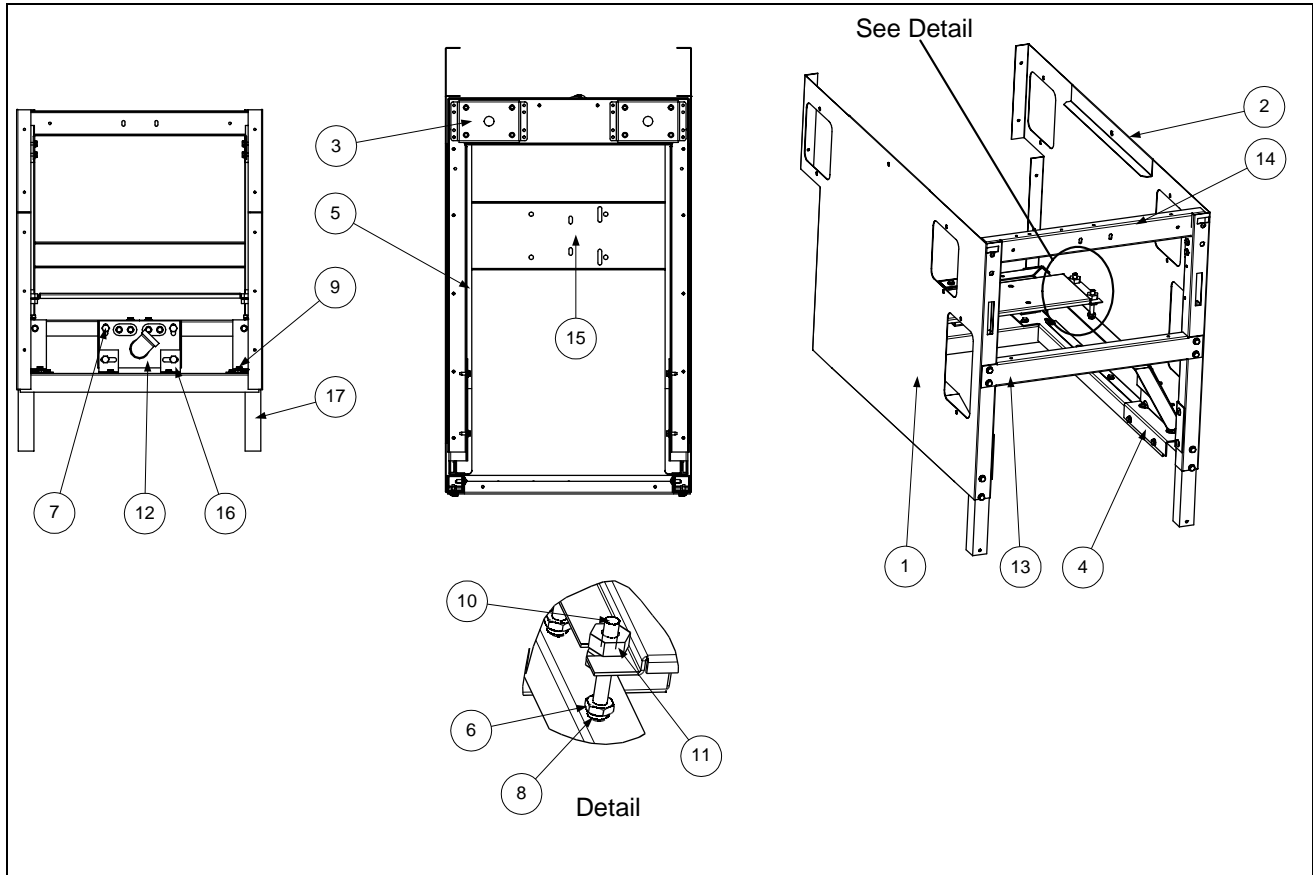

ITEM	PART #	COMPONENT
1	201-0483	Side, Cabinet U/C Enameled – Left
2	202-0483	Side, Cabinet U/C Enameled – Right
*	211-0483	Side, Cabinet U/C Stainless Steel – Left
*	212-0483	Side, Cabinet U/C Stainless Steel – Right
3	806-8059	Leg Pad Assembly
4	806-8062SP	Filter Rail Assembly, Common Electric FM
5	806-8935SP	Base Assembly, FM 3-Piece
6	826-1362	Nut, ¼ - 20 Hex (Pkg. of 10)
7	826-1389	Screw, Hex Head ¼ -20 x ¾ (Pkg. of 10)
8	809-0191	Washer, ¼ Lock
9	826-1374	Screw, #10- ½ Hex Head (Pkg. of 25)
10	809-0429	Bolt, ¼ -20 x 2
11	810-0665	Nut, Leveling
12	823-2827	Mount (Weld Assembly), Common Electric Single FP
13	900-4391	Brace, Cabinet Front
14	900-4785	Brace, Cabinet – Top and Center
15	900-8582	Mount, Motor Single FP Common Electric
16	900-8591	Bracket, Mount Common Electric Single FP
17	910-8659	Leg, Cabinet Front Common Electric Single FP

* Not illustrated.

2.3.4 FootPrint III, Filter Magic II and Non-Filter Options

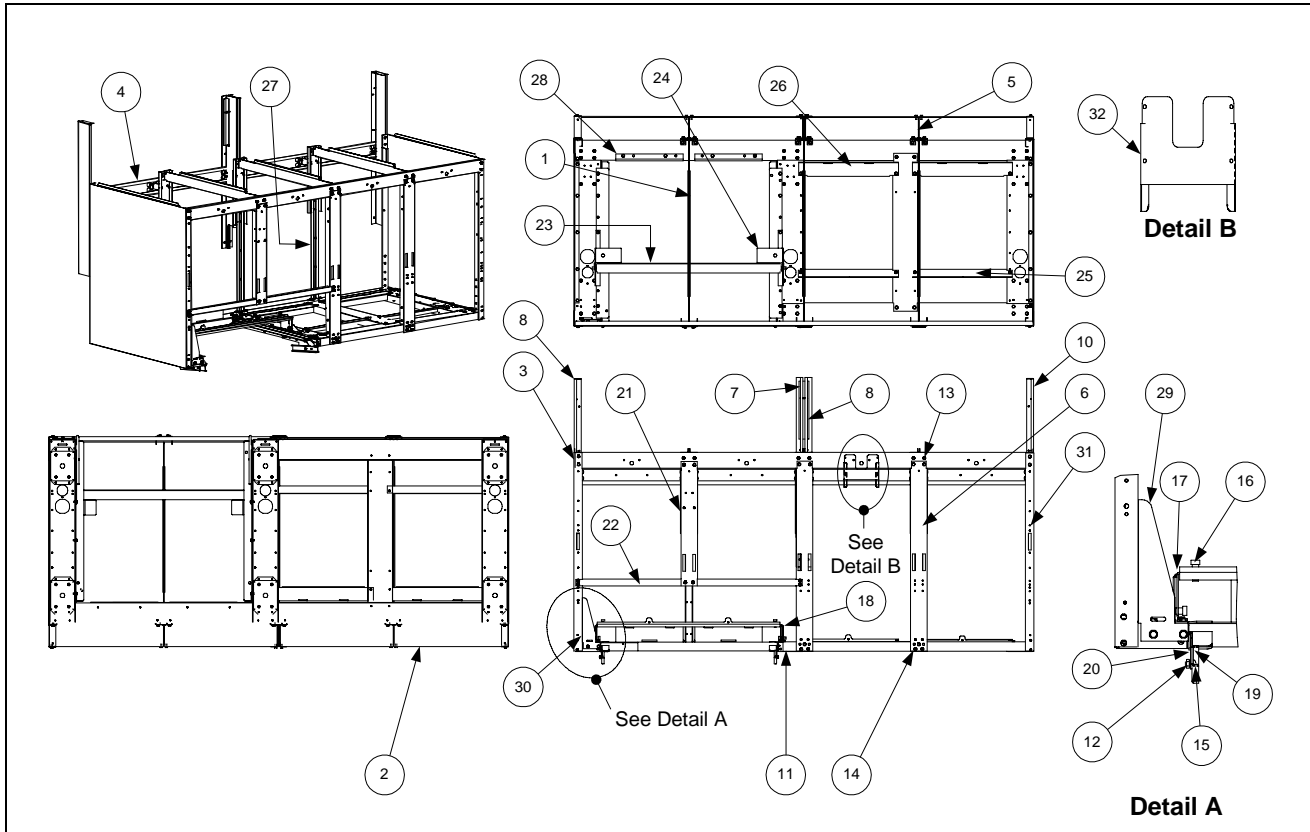

ITEM	PART #	COMPONENT
1	200-0076	Divider, Cabinet, Common Electric
2	200-0084	Brace, Rear Horizontal, 2 Battery (Quad and Double)
*	200-0085	Brace, Rear Horizontal, 3 Battery (Triple)
3	200-0091	Rail, Top- Quad Cabinet
*	200-0072	Rail, Top- Triple Cabinet
*	200-0081SP	Rail, Top- Double Cabinet
4	200-0092	Support, Rear, Common Electric
5	200-0126	Brace, Rear Support
6	200-0138	Door Post, Common Electric
7	201-0093	Enclosure, Rear Upright with Hole (Quad Only)
8	201-0137	Upright, Rear Enclosure, Common Electric
9	202-0093	Enclosure, Rear Upright with Hole (Quad Only)
10	202-0137	Upright, Rear Enclosure, Common Electric
11	806-7005SP	Base, Filter Assembly, Common Electric- Quad
*	806-6513SP	Base, Filter Assembly, Common Electric- Triple
*	806-6511SP	Base, Filter Assembly, Common Electric- Double
*	806-6997SP	Base Assembly, Common Electric N/F- Double
*	806-6999SP	Base Assembly, Common Electric N/F- Triple
*	806-7001SP	Base Assembly, Common Electric N/F- Quad
12	826-1376	Nut, 10-32 (Pkg. of 10)
13	826-1374	Screw, #10 1/2-Inch (Pkg. of 25)

Continued on following page.

ITEM	PART #	COMPONENT
14	809-0413	Spacer, Door Post (Quad and Triple Only)
15	809-0422	Screw, Shoulder- 10-32 x .40
16	809-0538	Bolt, Shoulder- ¼-20 x 3/8
17	823-2290	Front Bridge Support, Left
18	823-2291	Front Bridge Support, Right
19	900-1957	Lock Filter
20	900-1959	Bracket, Mounting, Filter Lock
21	900-2463	Post, Center Door, Common Electric
22	900-2464SP	Brace, Lower, Front Horizontal, Common Electric
23	900-2514	Bridge, Common Electric
24	900-2653	Plate, Swivel, Common Electric
25	900-2718	Brace, Contactor, Front, Common Electric w/Filter-Quad
*	200-0078	Brace, Contactor, Front, Common Electric [(w/Filter-Triple), N/F- Quad]
*	200-0075	Support, Contactor, Front, Common Electric N/F
26	900-2720	Brace, Contactor, Rear, Common Electric-Quad
*	200-0077	Brace, Contactor, Rear, Common Electric [(w/Filter-Triple), N/F- Quad]
*	200-0074	Support, Contactor, Rear, Common Electric N/F
27	900-2861SP	Support, Bottom, Common Electric
28	900-5988	Support, Rear, Bridge Filter, Common Electric
29	901-1810	Gusset, Cabinet, Left
*	902-1810	Gusset, Cabinet, Right
30	901-1948	Channel, Side Support
31	910-2456SP	Side, Cabinet – Stainless Steel, Common Electric
*	900-2456SP	Side, Cabinet – Enameled Steel, Common Electric
*	901-2843SP	Side, FM Common Electric w/Cut-out Left Cabinet, Enameled Steel
*	902-2843SP	Side, FM Common Electric w/Cut-out Right Cabinet, Enameled Steel
*	911-2843SP	Side, FM Common Electric w/Cut-out Left Cabinet, Stainless Steel
*	912-2843SP	Side, FM Common Electric w/Cut-out Right Cabinet, Stainless Steel
*	900-8451	Back, Lower Triple
*	900-8450	Back, Lower Double
*	900-5145	Back, Center Triple
*	900-5143	Back, Center Double
*	900-9635	Back, Upper Triple
*	900-9637	Back, Upper Double
32	900-9585	Heat Shield, Wire, Common Electric

* Not illustrated.

2.3.5 Common Electric Filter Magic Unitary Cabinetry (after 8/2000)

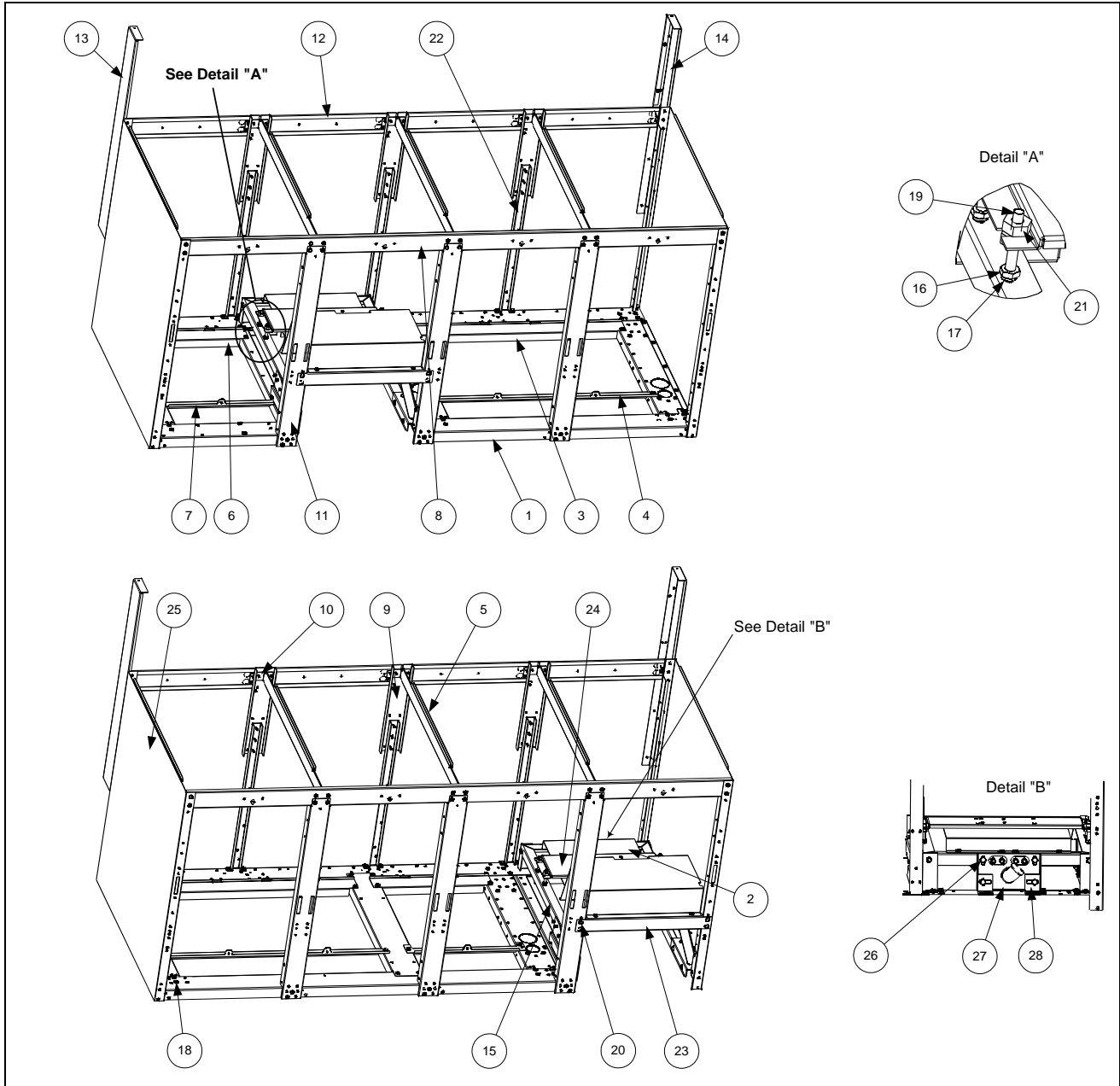

ITEM	PART #	COMPONENT
1	106-0215	Base Assembly, Quad—FM Common Electric (1F24)
*	106-0217	Base Assembly, Quad—FM Common Electric (31F2)
*	106-0218	Base Assembly, Quad—FM Common Electric (531F)
*	106-0220	Base Assembly, Quad—FM Common Electric (F246)
*	106-0214	Base Assembly, Triple—FM Common Electric (1F2)
*	106-0216	Base Assembly, Triple—FM Common Electric (31F)
*	106-0219	Base Assembly, Triple—FM Common Electric (F24)
*	106-0221	Base Assembly, Double—FM Common Electric (F2)
*	106-0222	Base Assembly, Double—FM Common Electric (1F)
2	200-0020	Shield, Filter Magic Pan CE
3	200-0074	Support, Rear Contactor Box
4	200-0075	Support, Front Contactor Box
5	200-0076	Divider, Cabinet Common Electric
6	200-0077	Brace, Rear Contactor Box
7	200-0078	Brace, Front Contactor Box Common Electric
8	200-0091	Brace (Rail), Top Quad Common Electric
*	200-0072	Brace (Rail), Top Triple Common Electric
*	200-0081SP	Brace (Rail), Top Double Common Electric
9	200-0092	Support, Rear Common Electric
10	200-0126	Brace, Rear Support
11	200-0138	Doorpost, Common Electric
12	200-0343	Brace, Rear Horizontal-Quad Common Electric
*	200-0085	Brace, Rear Horizontal-Triple Common Electric
*	200-0084	Brace, Rear Horizontal-Double Common Electric
13	201-0137	Upright, Rear Enclosure, Left, Common Electric
14	202-0137	Upright, Rear Enclosure, Right, Common Electric
15	806-8062SP	Filter Rail Assembly, Common Electric FM
16	826-1362	Nut, ¼ - 20 Hex (Pkg. of 10)
17	809-0191	Washer, ¼ Lock
18	826-1374	Screw, #10 - ½ Hex (Pkg. of 25)
19	809-0429	Bolt, ¼ - 20 x 2
20	826-1379	Screw, #10 x ½ Phillips (Pkg. of 10)
21	810-0665	Leveling Nut
22	900-2861SP	Support, Bottom Common Electric
23	900-4391SP	Brace, Cabinet Front
24	900-8582	Mount, Motor- Single FP Common Electric
25	910-2456SP	Side, Cabinet—Stainless Steel Common Electric
*	900-2456SP	Side, Cabinet—Cold Rolled Steel Common Electric
26	826-1389	Screw, Hex Head— ¼-20 x ¾ (Pkg. of 10)
27	823-2827	Mount (Weld Assembly) Common Electric Single FP
28	900-8591	Bracket, Mount – Common Electric Single FP

* Not illustrated.

2.4 Casters, Legs and Associated Hardware

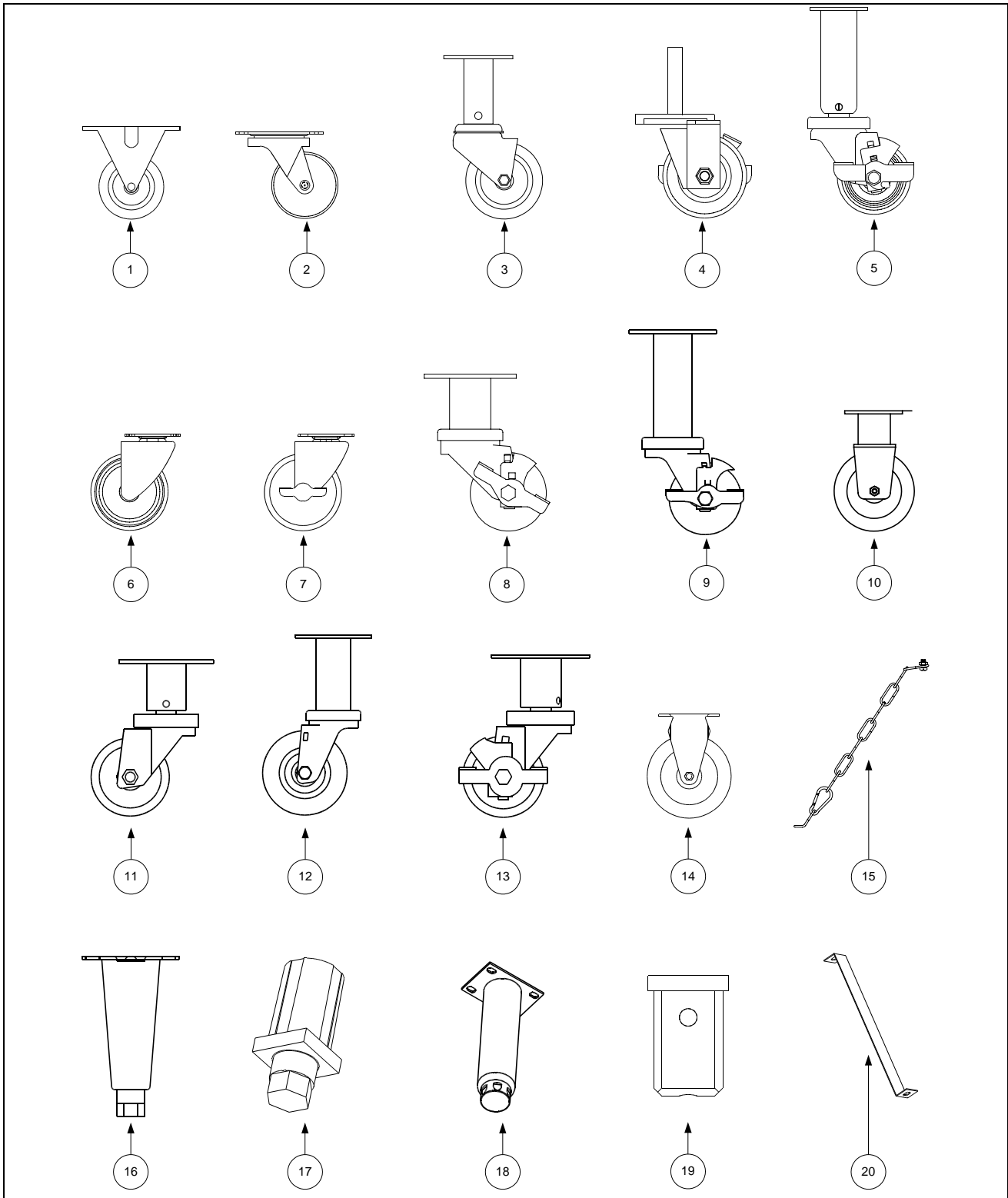

ITEM	PART #	COMPONENT
1	810-0005	Caster, Rigid
2	810-0006	Caster, Swivel-Rokite
3	810-0327	Caster, Adjustable, Without Brake
4	810-1565	Caster, Stud, Single FP 3-inch, With Lock
*	823-2844	Caster, With Brake – Single FP Electric
5	810-0944	Caster, Adjustable 3-inch With Brake
6	810-0356	Caster, 5-inch Wheel Without Brake
7	810-0357	Caster, 5-inch Wheel With Brake
8	810-0651	Caster w/Brake –FootPrint II
9	810-1239	Caster, 8.5-inch Swivel w/Brake (<i>for Cracker Barrel units, use 810-2737</i>)
10	810-1242	Caster, 8.5-inch Rigid
11	810-1367	Caster, Adjustable 3-inch w/o Brake
12	810-1494	Caster, 8.5-inch Swivel w/o Brake (<i>for Cracker Barrel units, use 810-2738</i>)
13	810-1365	Caster, Adjustable 3-inch w/Brake
14	810-0378	Caster, Stationary Rigid, 5-inch Wheel
15	826-0900	Chain Restraint Kit (for use on fryers w/casters)
16	806-3811	Leg, Package (4 per set)
17	810-0007	Leg, Adjustable (For 1 ¼-inch square tubing)
18	826-1234	Leg, Adjustable, 8.5-inch (with hardware)
19	810-1414	Insert, Square Leg, Baby FootPrint
*	910-7925	Leg ,Single FootPrint w/Caster Front Filter
*	910-1601	Leg, Square, Filter Cabinet Front
*	910-8659	Leg, Cabinet Front— Common Electric Single FootPrint
20	900-2941	Strap, Anchor—Common Electric
*	900-1835	Strap, Anchor—Single Fryers with Legs

* Not illustrated.

2.5 Component Box Assemblies and Associated Hardware

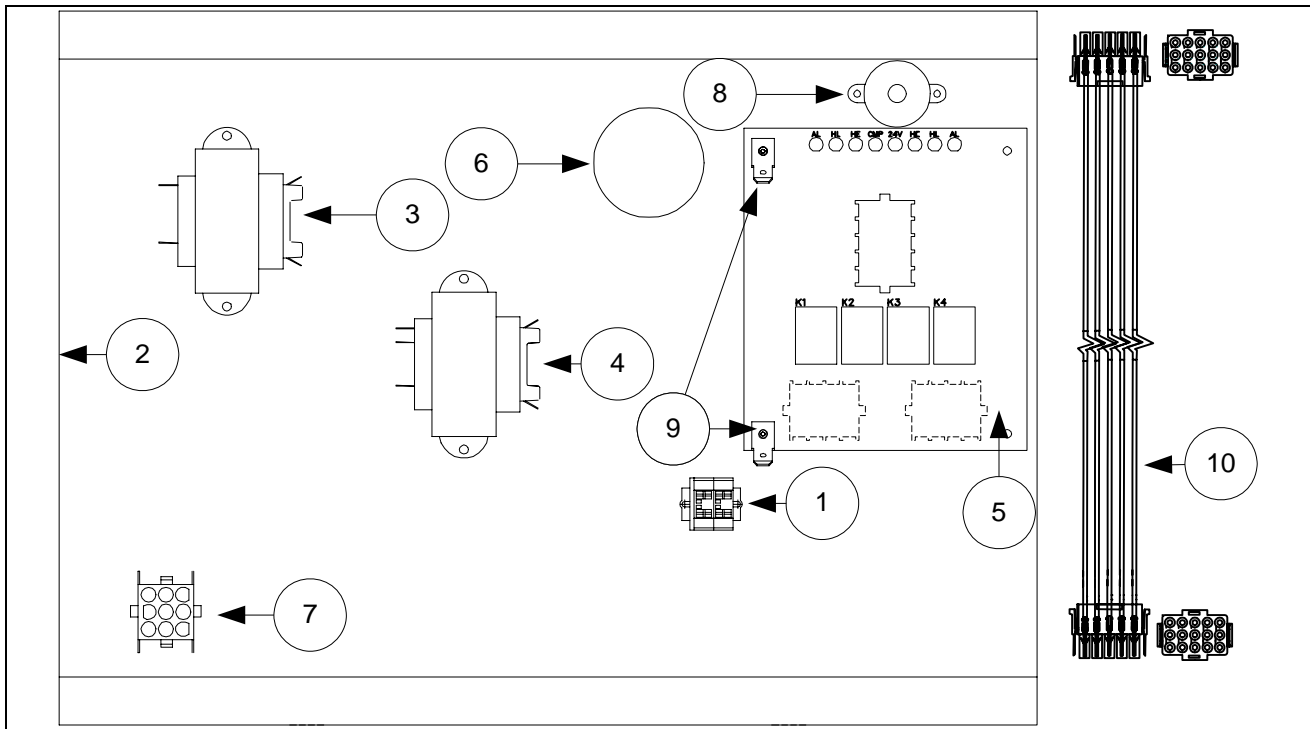

ITEM	PART #	COMPONENT
1	810-1164	Terminal Block Wire Assembly
2	806-8244	Component Box/Stud Assembly
3		Transformer, 12VAC
	807-2191	208-240 V
	807-0979	208-240V
	807-2192	100-120V
	807-0855	120V, 20VA
4		Transformer, 24VAC
	807-0680	208-240 V (without fuse)
	807-2180	208-240 V (with fuse)
	807-2181	100-120V, 62VA (with wires)
	807-0800	120V, 50VA (without wires)
*	807-1999	12/24 VAC Transformer, 208/220/230/240, 20/50 VA (Single FootPrint)
5		Interface Board
	806-6336	Standard Models
	806-3850	HE EF Models w/Rear Probe
	806-6347	Solid State (Triac) Models
	106-2982	Fast Computer
*	807-3932	Relay, Heat/Latch 12VDC SPDT 12A
6	807-1084	Bushing
7	806-6854SP	Wiring Assembly, Transformer
8	806-7179SP	Sound Device
9	826-1337	Terminal Tab (Pkg. of 5)
10	806-2071	Cable Assembly, Computer/Interface Board

* Not illustrated.

2.6 Control Panel Assemblies, Doors, and Related Components

2.6.1 Control Panel Assemblies, Top Caps, and Associated Components

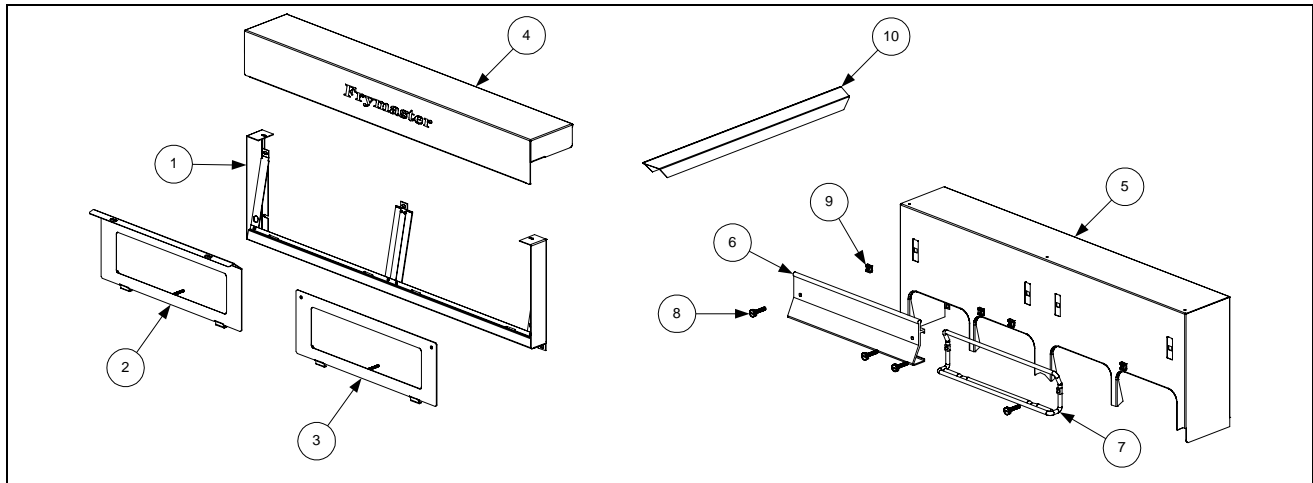

ITEM	PART #	COMPONENT
1		Control Panel Assembly
	806-7171SP	Single Fryer
	806-7172SP	Two-Fryer Battery
	806-7173SP	Three-Fryer Battery
	806-7174SP	Four-Fryer Battery
	106-2171SP	Five-Fryer Battery
	106-2324SP	Applebee's Fryer with Dump Station on Left
	106-2325SP	Applebee's Fryer with Dump Station on Right
2	823-2307	Control Panel Bezel, with Slot
3	823-0768	Control Panel Bezel, without Slots (for Digital and Analog Controllers)
4		Topcap
	106-3034SP	Single Non-Filter
	824-0409	Single FootPrint (<i>requires Item 9 also</i>)
	106-3033SP	Double
	106-3035SP	Triple
	106-3036SP	Quad Common Electric
	824-1037	5-Battery (<i>requires Item 9 also</i>)
	824-1047	Applebee's Fryer with Dump Station on Left (<i>requires Item 9 also</i>)
	824-1048	Applebee's Fryer with Dump Station on Right (<i>requires Item 9 also</i>)
5		Tilt Housing
	824-0791	Single
	824-0789	Double
	824-0798	Triple
	824-0799	Quad
	824-0852	5-Battery
6		Basket Hanger, Aluminum (No longer available, use Item 7)
7	810-1403	Basket Hanger, Wire
8	809-0171	Screw, Basket Hanger
9	826-1351	Cage Nut (Pkg. of 10) (receives Basket Hanger Screw)
10	823-1885	Top Connecting Strip

2.6.2 Door Assembly Components

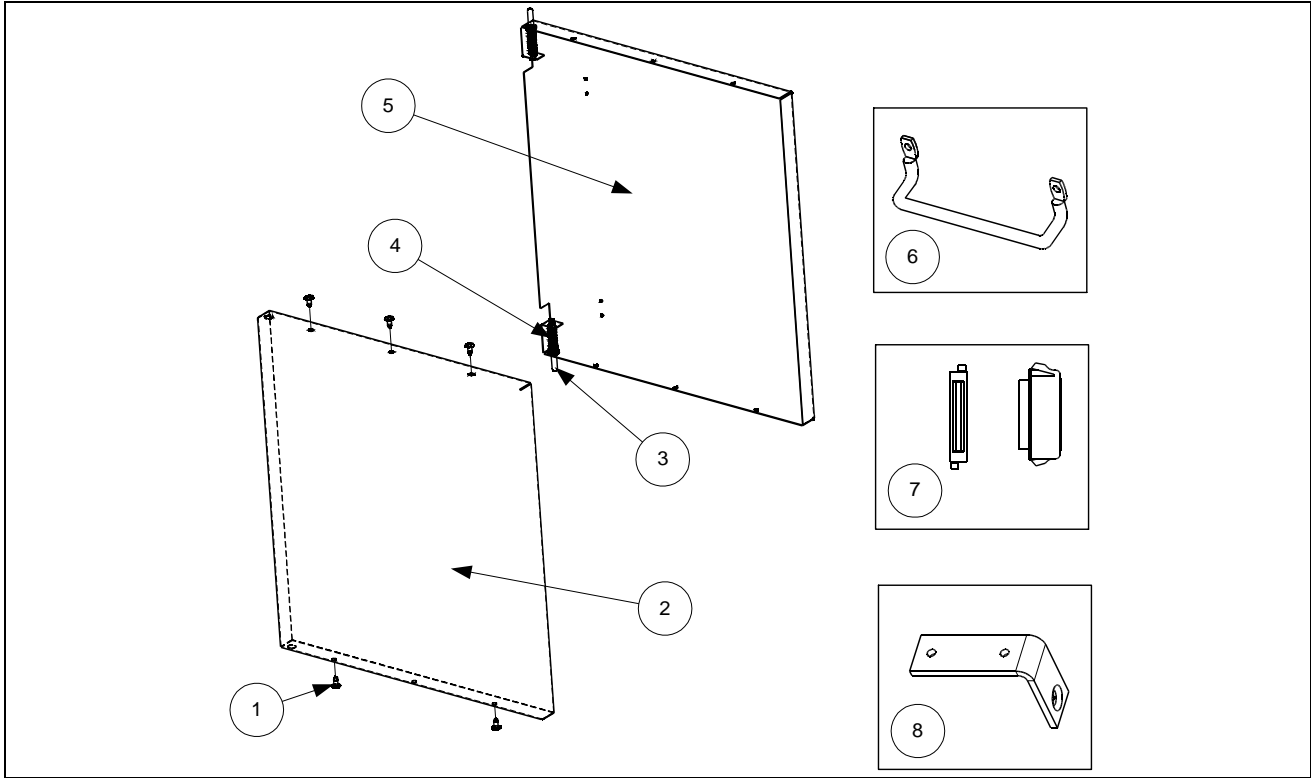

ITEM	PART #	COMPONENT
	806-6545SP	Door Assembly, Universal
1	809-0266	Screw, #10- 1/2-inch
2	824-0137SP	Panel, Door
3	806-4487SP	Door Pin Assembly
*	809-0193	Washer, Flat 1/4-Inch Nylon (Door Pin Bushing)
4	826-1343	Spring, Door Hinge (Pkg. of 10)
5	900-2485	Liner, Door
6	810-1422	Handle, Wireform, Door
7	810-1105	Magnet, Door
8	810-1508	Hinge, Universal Door

* Not illustrated.

2.7 Controller Assemblies

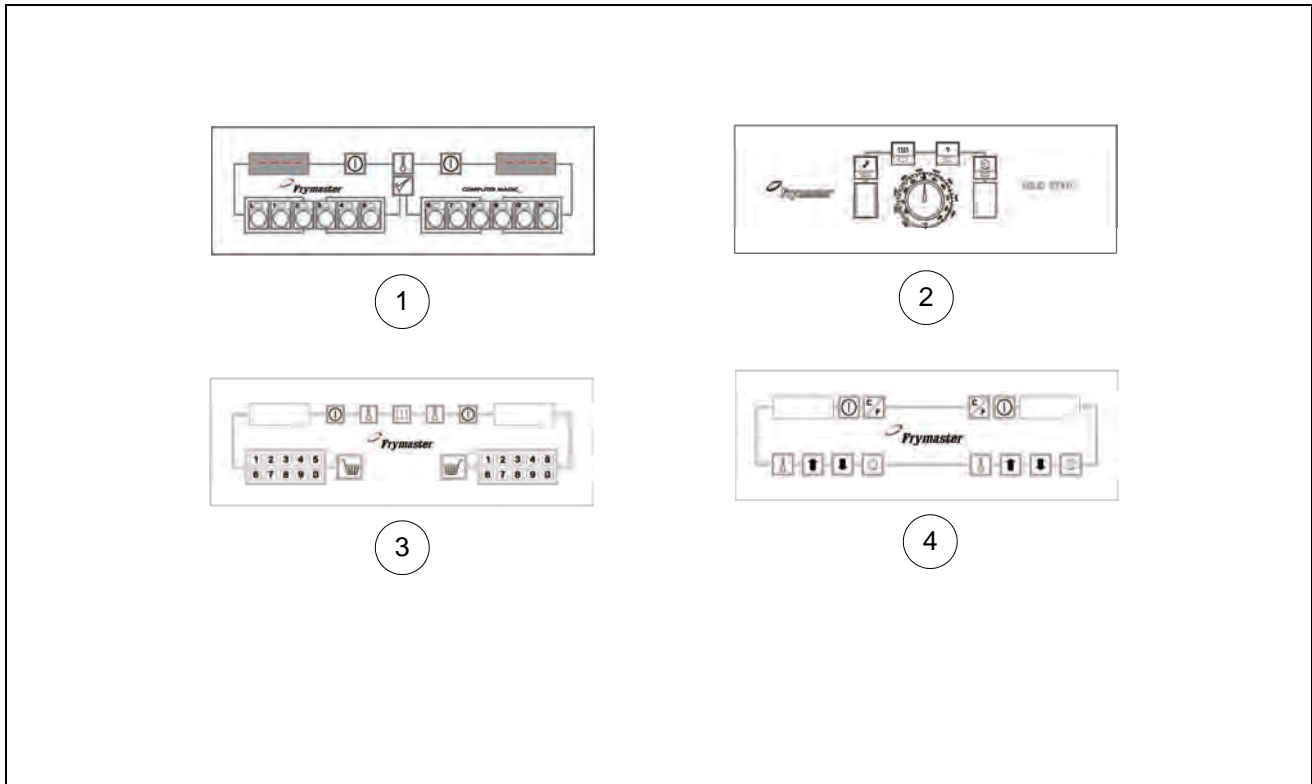

ITEM	PART #	COMPONENT
1		Computer Magic III
	106-1193	Full-vat (CE)
	106-1194	Dual-vat (CE)
	806-7158	Full-vat (Domestic)
	806-7159	Dual-vat (Domestic)
	806-7162	Full-vat (Triac/Solid-State)
	806-7163	Dual-vat (Triac/Solid-State)
2		Analog Controller
	806-7422	Full-vat
	806-7423	Dual-vat
3		Basket Lift Timer
	106-2090SP	Full-vat (CE)
	106-2091SP	Dual-vat (CE)
	106-2088SP	Full-vat (Domestic)
	106-2076SP	Dual-vat (Domestic)
4		Digital Controller
	106-1507	Full-vat (CE)
	106-1508	Dual-vat (CE)
	106-1503	Full-vat (Domestic)
	106-1952	Dual-vat (Domestic)

2.8 Electrical Components

2.8.1 Contactor Box Components, Mercury Contactor

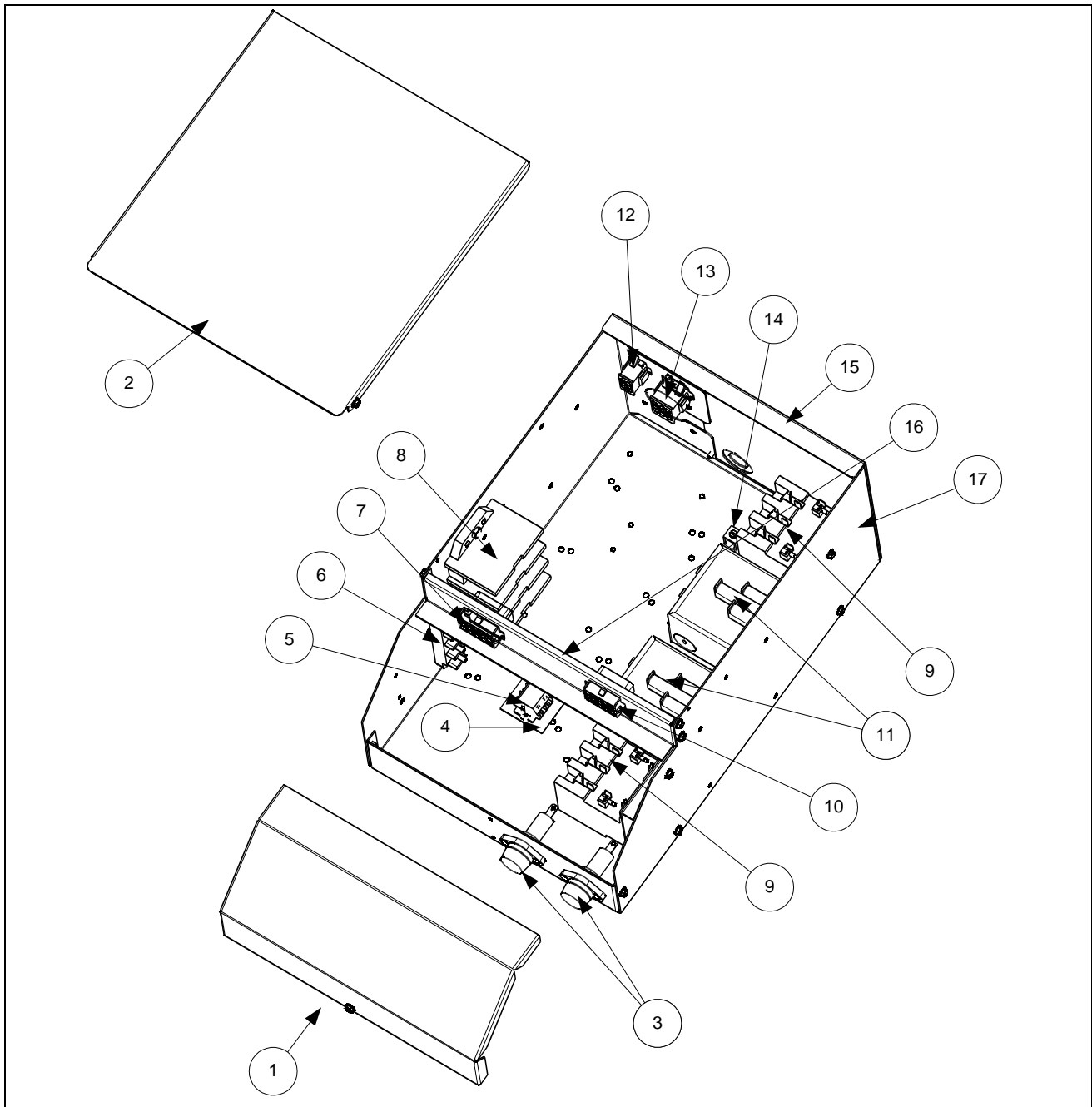

ITEM	PART #	COMPONENT
1	900-5445	Front Cover, Contactor Box
2	900-5446	Top Cover, Contactor Box
3	807-0922	Holder, Buss Fuse
*	807-2278	Fuse, 20 Amp
*	807-2279	Fuse, 15 Amp
*	807-0501	Fuse Block 3-Pole Buss (22kW)
*	807-2240	Fuse 60 Amp (22kW)
*	807-2865	Block Support, Fuse (22kW)
4	816-0217	Paper, Insulating Terminal Block (CE)
5	810-1164	Terminal Block
6	807-1973	Terminal Post
7		C1 Wiring Assembly
	806-7198SP	For Dual-vat Applications
	806-7199SP	For Full-vat Applications
8	807-2464	Power Block, Delta
*	807-2465	Power Block, WYE
9	810-1202	Contactor, 3-Pole 600V 40 Amp
10		C2 Wiring Assembly
	806-7191SP	Dual- and Full-vat
11	807-1071	Contactor, Mercury 24 VAC 30 Amp
*	807-0884	Contactor, Mercury 24 VAC 50 Amp (See NOTE)
12	806-7183SP	Wire Assembly, Left, Dual-vat
*	806-7186SP	Wire Assembly, Left, Full-vat
*	807-2136	Connector, 6-Pin Female
*	807-2135	Connector, 6-Pin Male
13	806-7185SP	Wire Assembly, Right (Full- and Dual-vat)
*	807-2138	Connector, 9-Pin Female
*	807-2137	Connector, 9-Pin Male
14	807-0070	Terminal, Ground Lug
15	900-5447	Back Cover, Contactor Box
16	900-5782	Bracket, Connector Common Electric
17	900-5444	Box, Contactor Common Electric

* Not illustrated.

NOTE: For H22 Models using 208-240V, but not 480V.

2.8.2 Contactor Box Components, Solid State Relays (Triac)

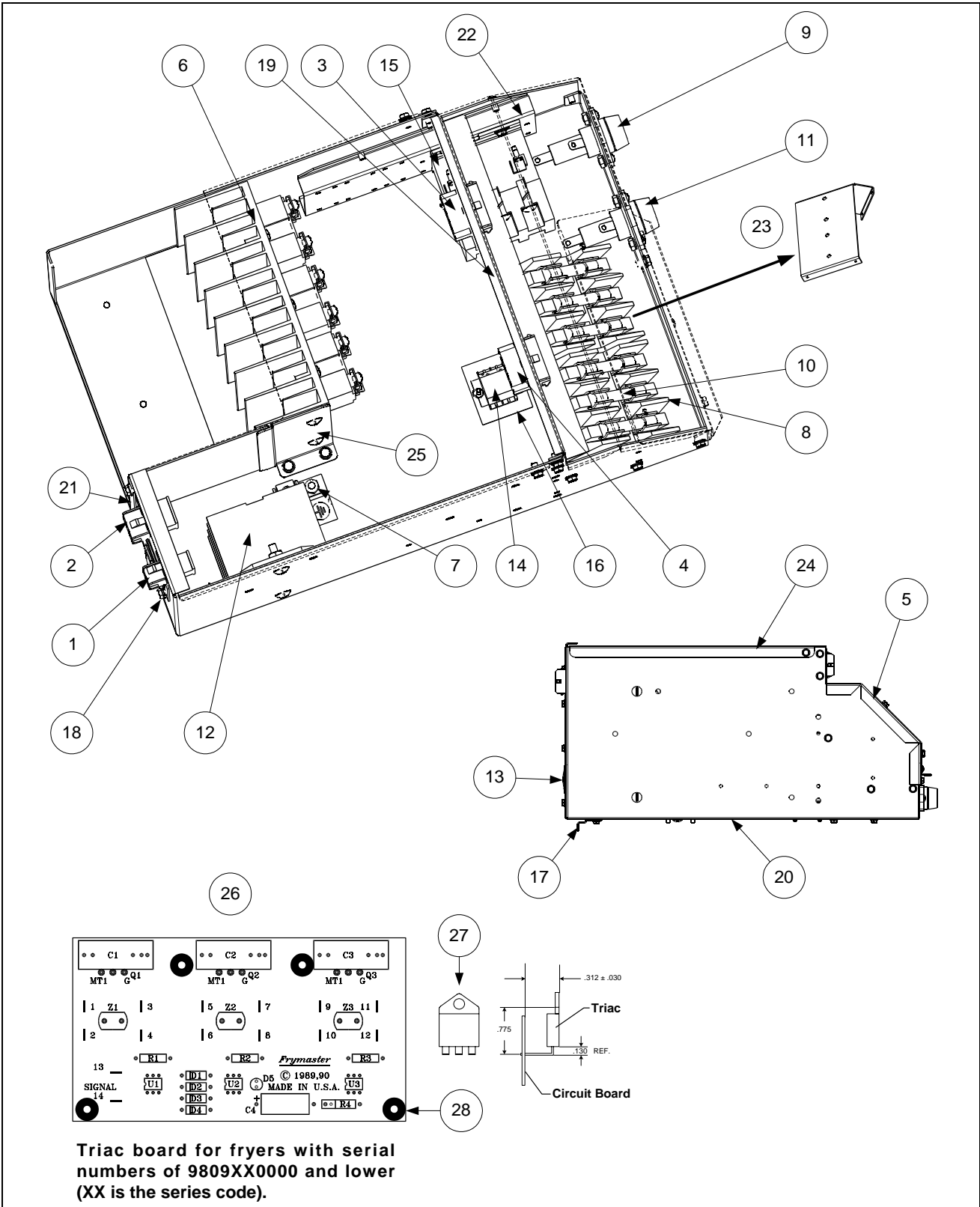

ITEM	PART #	COMPONENT
1	806-7185SP	Wire Assembly, HV Right Contactor
*	806-7184SP	Wire Assembly, HV Right FV H22 Contactor
2	806-7186SP	Wire Assembly, HV Left FV Contactor
*	806-7188SP	Wire Assembly, HV Left FV H22 Contactor
*	806-7183SP	Wire Assembly, HV Left DV Contactor
3	806-7191	C2 Wire Assembly, Common Electric
4	806-7198	C1 Wire Assembly, Dual-vat Common Electric
*	806-7199	C1 Wire Assembly, Full-vat Common Electric
5	806-8589	Front Assembly, Fuse Contactor Box Common Electric
6	806-8673	Heat Sink Assembly, Full-vat Solid State Relay
*	806-8674	Heat Sink Assembly, Dual-vat Solid State Relay
*	826-1562	Kit, 40A 280V Relay w/Heat Sink Compound
7	806-0070	Terminal, Ground Lug
8	807-0501	Fuse Block, Buss #2968 3-Pole
9	807-0922	Holder, Buss Fuse HPS
10	807-2240	Fuse, Buss 60 Amp 300 VAC
11	807-2278	Fuse, 20 Amp
12	807-2464	Power Block, Delta Common Electric
*	807-2465	Power Block, WYE Common Electric
*	806-9124	Filter Assembly (WYE Solid-State/Triac Contactor Box Only)
13	810-0743	Button, Plug ¾-inch
14	810-1164	Terminal Block, 1 PLC Screwless
*	807-0064	Transformer-150VA, 480V Applications, w/o Basket Lift
*	807-0331	Transformer-250VA, 480V Applications, w/Basket Lift
15	810-1202	Contactor, 3-Pole 600V 40 Amp
16	816-0217	Paper, Insulating Terminal Block CE
17	900-2519	Hinge, Control Box Common Electric
18	900-2752	Plate, Cordset Common Electric
19	900-5782	Bracket, Connector Common Electric Box
20	900-5784	Box, Contactor Common Electric
21	900-5785	Rear, Triac Contactor Box Common Electric
22	900-5786	Rail, 2-Contactor Common Electric
23	900-5797	Support, Fuse Block Common Electric
24	900-5895	Top, Triac Contactor Box Common Electric
25	900-8239	Rear, Split Triac Contactor Box
26	806-5072	Triac Board Assembly (2 required for Dual-vat Applications)
*	812-1283	Heat Sink, Triac Board
27	807-1276	Triac 600/40A TO-218
*	815-0554	Heat Sink Compound (required for installing Triac Board to Heat Sink)
28	807-1337	Standoff, Triac Board

* Not illustrated.

2.8.3 Elements and Related Components

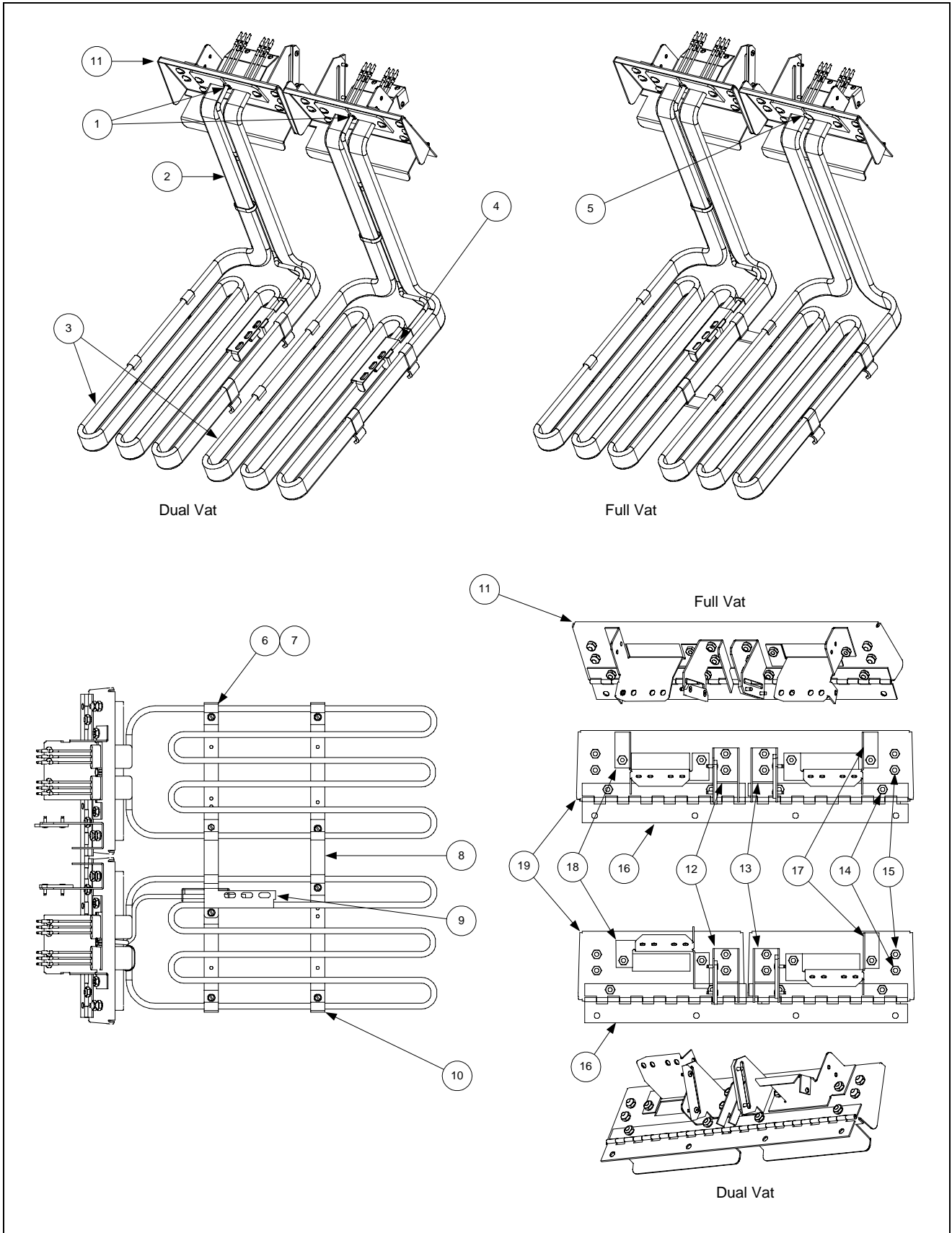

ITEM	PART #	COMPONENT
1	826-1339	Bushing, .375 Split (Pkg. of 10)
2	809-0567	Ty-Wrap, Metal
3		Heating Element
	807-2639	208V 7 kW
	807-2640	208V 8.5 kW
	807-2641	220V 8.5 kW
	807-2642	230V 7 kW
	807-2643	230V 8.5 kW
	807-2644	240V 7 kW
	807-2645	240V 8.5 kW/ 220V 7 kW
	807-2646	200V 8.5 kW
	807-2647	380V 7 kW
	807-2648	380V 8.5 kW
	807-2649	440V 7 kW
	807-2650	440V 8.5 kW
	807-2651	480V 7 kW
	807-2652	480V 8.5 kW
	807-2653	400V 8.5 kW
	807-3171	220V 11 kW
	807-3172	230V 11 kW
	807-3173	240V 11 kW
	807-3174	200V 11 kW
	807-3175	380V 11 kW
	807-3176	440V 11 kW
	807-3177	480V 11 kW
	807-3178	400V 11 kW
	807-3237	208V 11 kW
*		Heating Element Assemblies
	806-3141SP	208V, 14kW Full-vat
	806-3142SP	240V 7kW Dual-vat
	806-8474SP	240V 14 kW Full-vat
	806-7887SP	230V H22, Dual-vat
	806-8497SP	440V H14/17, Full-vat
	806-8677SP	In-N-Out 208V 22kW
4	807-2478	Temperature Probe
5	816-0480	Dome Plug, .375 OD. (Full-vat Only)
6	809-0518	Screw #8 32 x 3/8-inch
7	910-2042	Clamp, Element
8	910-3681	Element Support, Full-vat
*	910-5214	Element Support, Dual-vat
9	910-5022	Bracket, Temperature Probe
10	910-5213	Clamp, H14/H17 Element
11	106-0003SP	Tilt Plate Assembly, Full-vat
*	106-0004SP	Tilt Plate Assembly, Dual-vat
12	106-0573SP	Spring Slot Bracket Assembly, Right
13	106-0572SP	Spring Slot Bracket Assembly, Left
*	810-0297	Spring, Element (14 and 17kW only)

Continued on following page.

ITEM	PART #	COMPONENT
*	810-1546	Spring, Element (22kW only)
		Tilt Plate Assembly, Individual Components
14	826-1330	Screw, 10-32 x 3/8 (Pkg. of 25)
15	826-1376	Nut, 10-32 (Pkg. of 10)
16	810-0035	Hinge, Stainless Steel Split—14-Inch
17	901-8509	Bracket, Element Support, Left
18	902-8509	Bracket, Element Support, Right
19	910-9640	Plate, Tilt, Full-vat (1 Required)
19	910-9641	Plate, Tilt, Dual-vat (2 Required)
*	826-1061	Tilt Switch, Mercury Non-CE (Full-Vat requires one switch and Dual-Vat requires two.)
*	826-2228	Tilt Switch, CE (Full-Vat requires one switch and Dual-Vat requires two.)

* Not illustrated.

THIS PAGE INTENTIONALLY LEFT BLANK

2.9 Filter Base/Pan Assemblies

2.9.1 Filter Base Assemblies and Components, FootPrint III

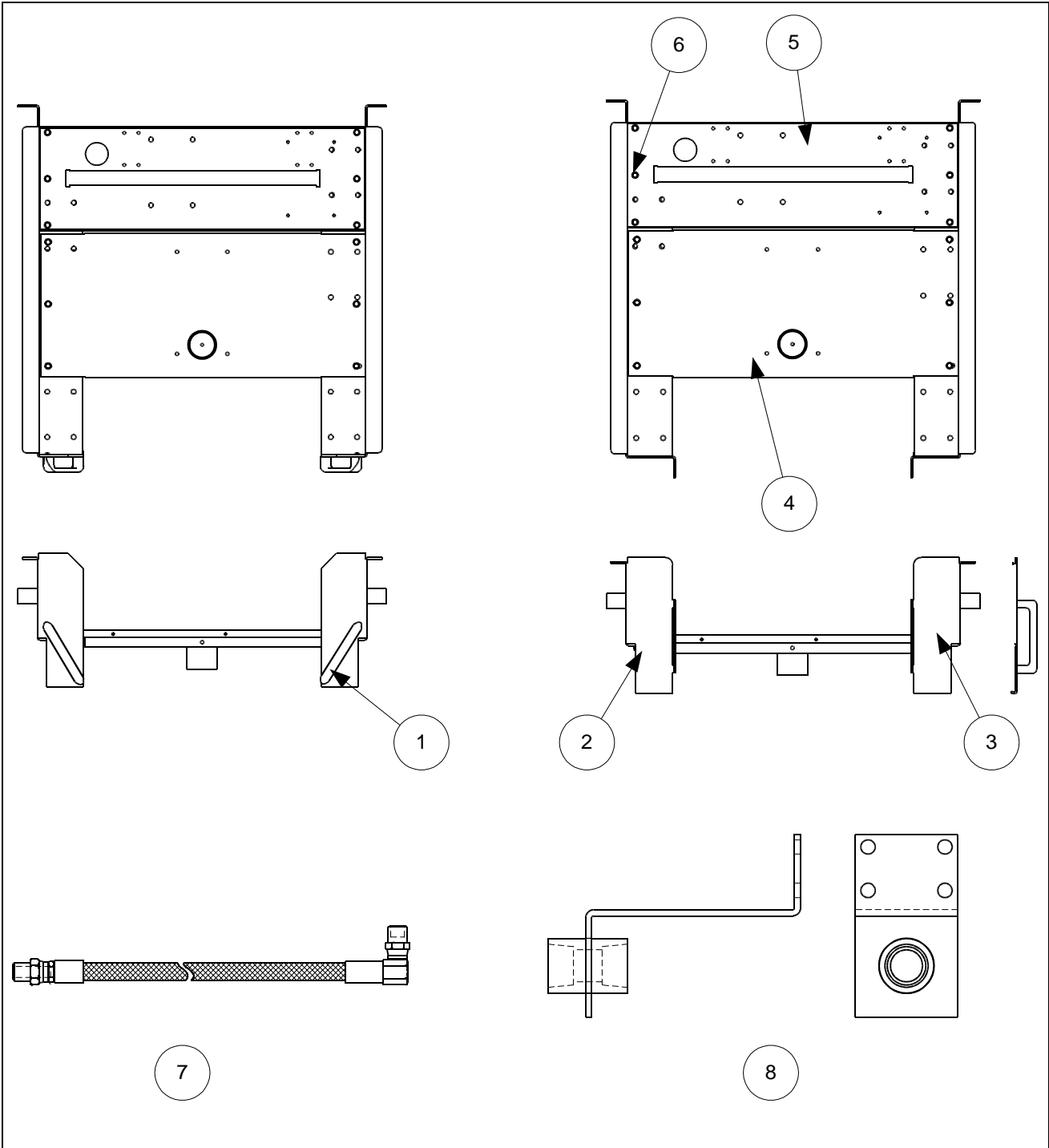

ITEM	PART #	COMPONENT
	806-8648SP	Filter Base Assembly, FootPrint III (After 8/97)
	806-5985SP	Filter Base Assembly, FootPrint III w/Casters (Before 8/97)
1	810-0180	Handle, Filter Base Assembly
*	826-1360	Screw, #10-24 x 5/16 [Pkg. of 25 (to attach P/N 810-0180)]
2	901-8542	Filter Base, Left Side
3	902-8542	Filter Base, Right Side
4	823-2289	Filter Pan Support
5	900-5396	Motor Support
6	826-1374	Screw, #10-1/2 Hex Head (Pkg. of 25)
*	900-5477	Cover, Motor (August 1997 and later)
*	824-0558	Cover, Motor (Prior to August 1997)
*	900-1949	Standoff, Filter Wiring Box
7	810-1423	Hose, Oil Return
8	823-2638	Bracket, Oil Return Hose

* Not illustrated.

NOTE: Item 1 (P/N 810-0180 Handle, Filter Base Assembly) is available as a replacement for damaged handles on base assemblies manufactured from 8/97 to 8/99. If damaged filter bases need replacement, they must be replaced with P/N 901-8542 and 902-8542, which include handles. Filter bases with replaceable handles are no longer available.

2.9.2 Filter Pan Assemblies, Single FootPrint and FootPrint III

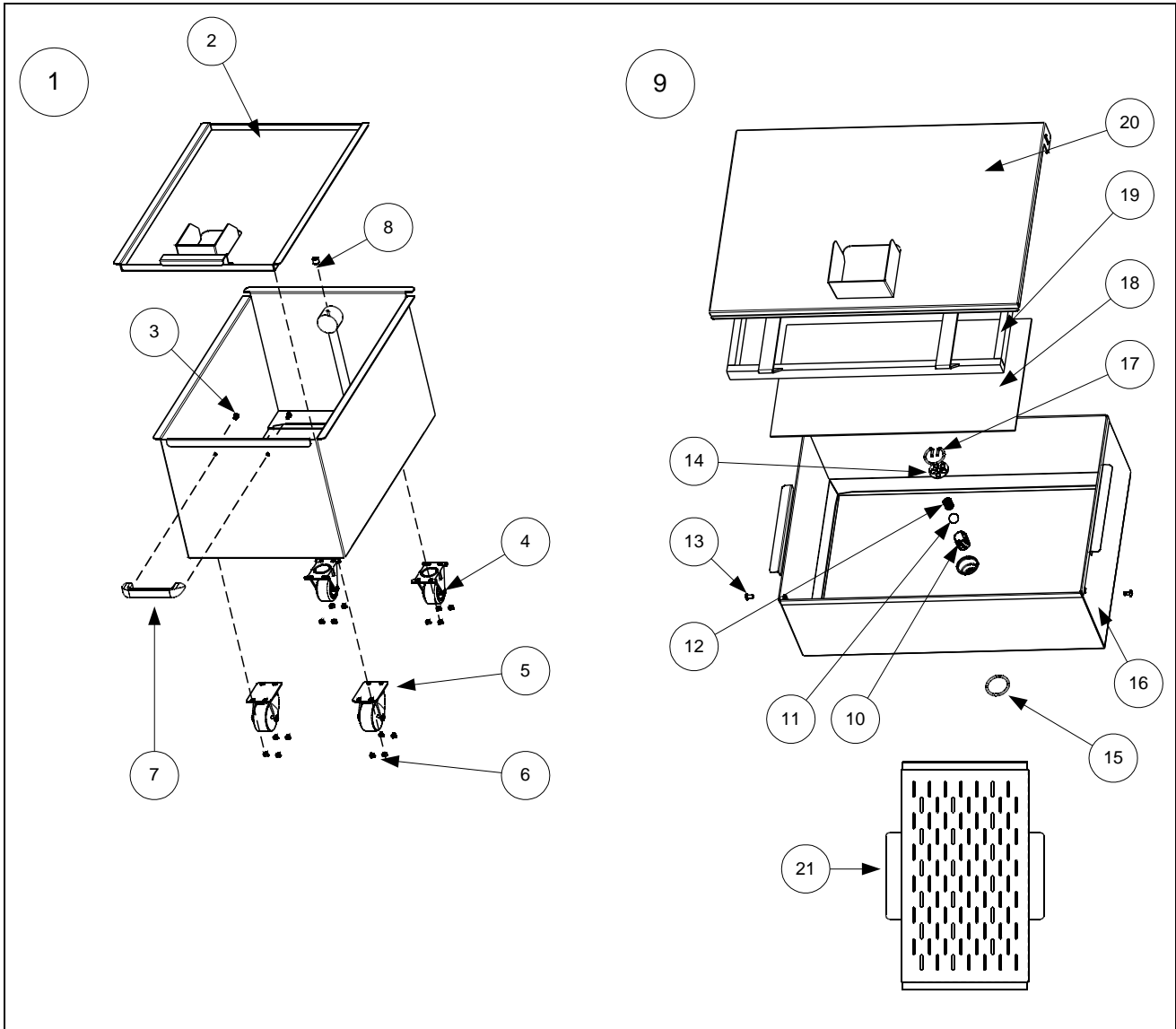

ITEM	PART #	COMPONENT
1	806-9546SP	Filter Pan Assembly, Single FootPrint [See Section 2.9.3 Filter Magic II (Before 2/99)] for filter screen, crumb screen and other inner-pan components)
*	823-2828	Filter Pan
2	806-9547SP	Cover Assembly, Filter Pan
*	809-0045	Nut, 10-32
*	809-0117	Screw, 10-32 x 3/8 SS
*	809-0185	Washer, Flat #10
*	910-1816	Handle, Filter Pan, Single FootPrint
3	826-1360	Screw, 10-24 x 5/16 (Pkg. of 25)
4	810-0005	Caster, Rigid
5	810-0006	Caster, Swivel
6	826-1376	Nut, 10-32 (Pkg. of 10)
7	810-0180	Handle, Door
8	813-0411	Plug, Pipe-1/8 Internal Hex
9	806-5618SP	Filter Pan Assembly, FootPrint III
10	810-1388	Tube, Check Valve
11	810-0948	Ball, Check Valve
12	810-0946	Spring, Check Valve
13	809-0422	Screw, Shoulder 10-32 x 7/16
14	900-5448	Strain Plate, Check Valve
15	816-0181	O-Ring, Check Valve
16	823-1979SP	Filter Pan
17	810-1387	Retainer, Check Valve
18	900-8819	Screen, Filter
19	810-1405	Hold-down Ring
20	823-2027	Cover, Filter Pan
21	824-0430	Screen, Crumb
*	826-1490	Kit, Filter Pan Check Valve Service (Items 10, 11, 12, 14, 15, and 17)

* Not illustrated.

2.9.3 Filter Pan Assemblies, Filter Magic II (Before 2/99)

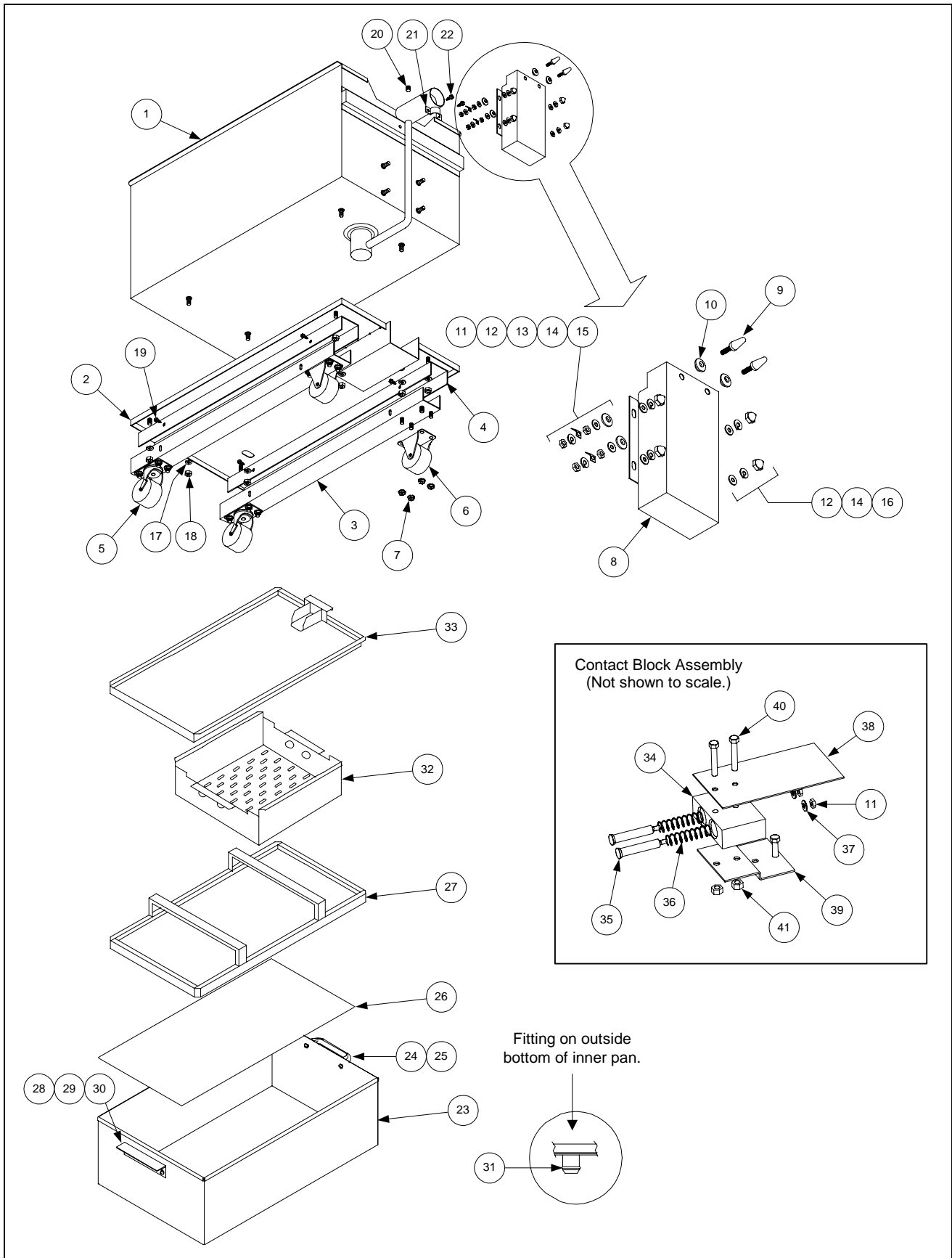

ITEM	PART #	COMPONENT
	806-7411SP	Outer Pan Assembly (Includes Items 1-22)
1	823-1360SP	Outer Pan
2	823-2332	Base, Filter Pan Assembly
3	806-9471	Channel, Caster Mounting
4	900-2805	Channel, Caster Lift Base
5	810-0006	Caster, Swivel
6	810-0005	Caster, Rigid
7	826-1376	Nut, 10-32 Hex Keps (Pkg. of 10)
8	824-0291	Cover, Suction Tube
9	810-0695	Contact, Pan
10	807-1270	Washer, Insulated Shoulder
11	809-0053	Nut, 10-32 Hex
12	809-0184	Washer, #10 Lock
13	826-1337	Tab, Terminal (Pkg. of 5)
14	809-0185	Washer, #10 Flat
15	807-1367	Washer, Non-Conductive Flat
16	809-0020	Nut, 10-24 Cap
17	809-0189	Washer, ¼-inch Flat
18	826-1362	Nut, ¼-20 Hex (Pkg. of 10)
19	826-1374	Screw, #10 X ½-inch Hex Washer Head (Pkg. of 25)
20	813-0411	Plug, ⅛-inch Hex Head Pipe
*	806-4373	Heater Strip Assembly, 24V 25W
*	811-0861	Insulation, Foam (Heater Strip)
*	811-0746	Tape, Aluminum (50-yard Roll)
*	810-0441	Clamp, Heater (Aluminum)
21	910-1350	Clamp, Suction Tube
22	826-1371	Screw, #8 X ½-inch Hex Head Drill Point (Pkg. of 25)
	806-5282SP	Inner Pan Assembly (Includes Items 23-31)
23	823-1731SP	Inner Pan
24	810-0180	Handle, Filter Pan
25	809-0024	Screw, 10-24 X 5/16-inch Slotted Round Head
26	900-8827	Screen, Filter (SanaGrid)
27	810-1406	Ring, Hold Down
28	910-1366	Handle, Filter Pan
29	809-0117	Screw, 10-32 X 5/16-inch Slotted Truss Head
30	809-0045	Nut, 10-32 Hex Cap
31	816-0117	O-Ring
32	824-0416	Screen, Crumb
33	823-1390	Cover, Filter Pan
	806-4694SP	Contact Block Assembly (Includes Items 11 and 34-41)
34	810-0694	Block, Contact
35	810-0693	Pin, Contact
36	810-0696	Spring, Contact Pin
37	809-0185	Washer, #10 Flat
38	816-0126	Insulator, Contact Block
39	900-1521	Bracket, Contact Block
40	809-0291	Screw, ¼-20 X 1.5-inch
41	826-1372	Nut, ¼-20 Hex Grip (Pkg. of 10)

* Not Illustrated.

2.9.4 Filter Pan Assembly, Filter Magic II One-Piece

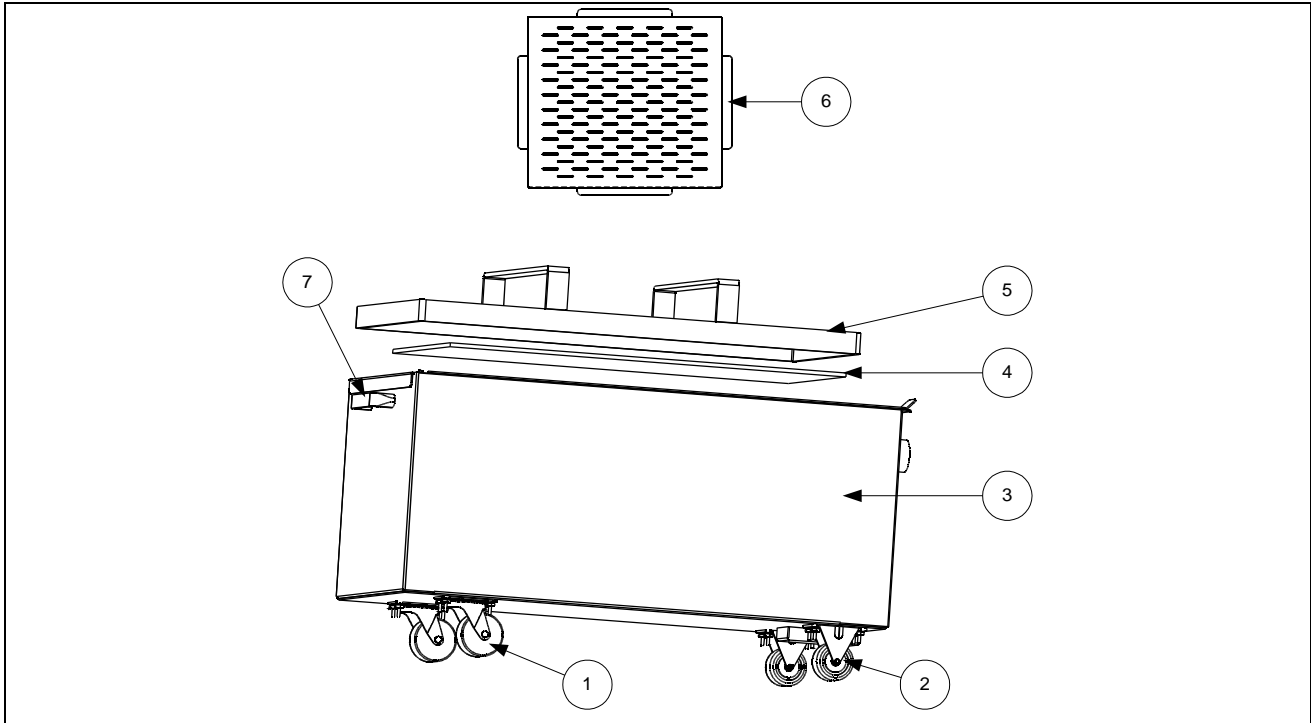

ITEM	PART #	COMPONENT
		Complete Pan Assemblies
	106-0361SP	After July 2000
	806-9449SP	Between March 1999 and July 2000
	106-0090SP	Carl's Jr. w/Magnasol Filter
1	810-0006	Caster, Swivel
2	810-0005	Caster, Rigid
3		Pan, Filter
	823-2828SP	Used with Filter Pan Assembly 106-0361SP
	823-2751SP	Used with Filter Pan Assembly 806-9449SP
	823-2951SP	Used with Filter Pan Assembly 106-0090SP
4		Screen, Filter (SanaGrid)
	900-8933	Used with Filter Pan Assembly 106-0361SP
	900-8827	Used with Filter Pan Assembly 806-9449SP
5		Ring, Hold Down
	823-2899	Used with Filter Pan Assembly 106-0361SP
	810-1406	Used with Filter Pan Assembly 806-9449SP
6	824-0416	Screen, Crumb
7	810-0180	Handle, Filter Pan
*	826-1360	Screw, 10-24 X 5/16-inch Slot Head

* Not illustrated.

2.10 Filter Pump and Motor Assemblies and Associated Hardware.

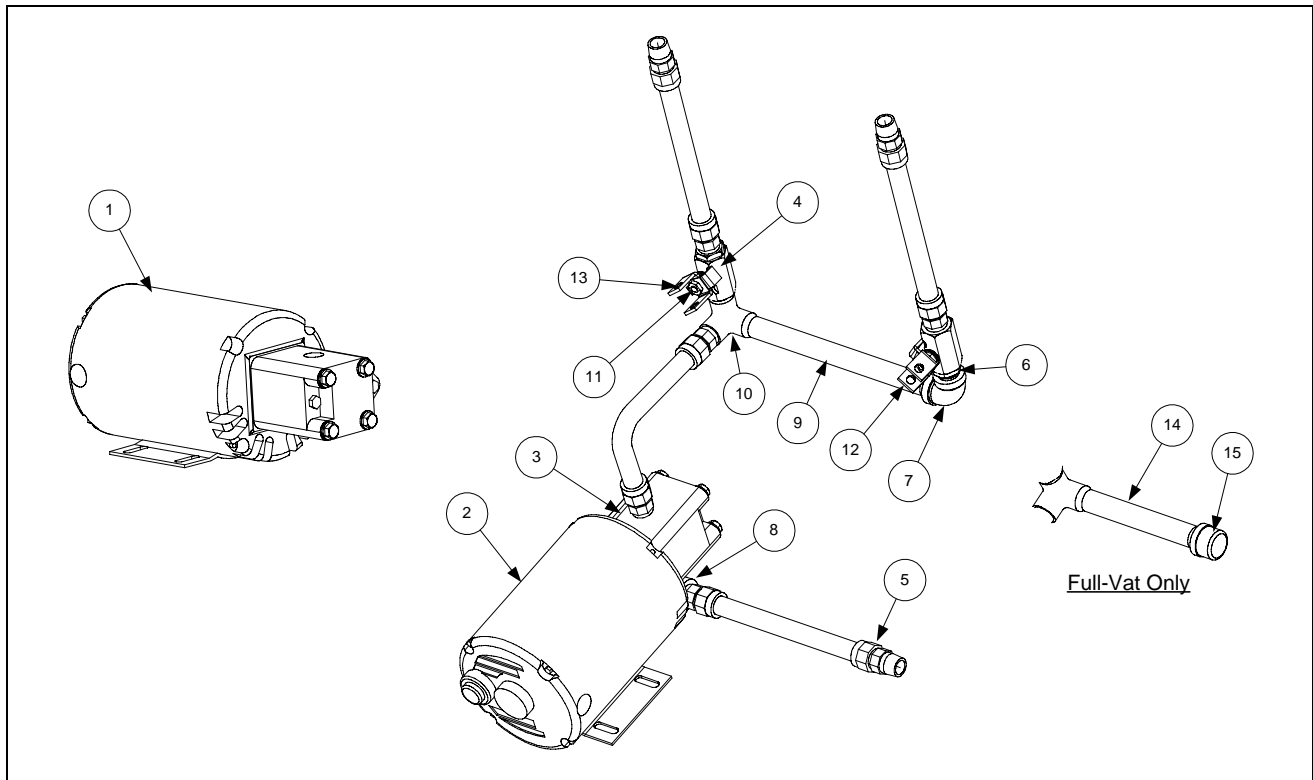

ITEM	PART #	COMPONENT
1		Pump and Motor Assembly (Illustration Purposes Only)
2	826-1270	Motor and Gasket Kit, 230V-250V 50/60 Hz
*	826-1756	Motor and Gasket Kit, 208V 50/60 Hz
*	826-1712	Motor and Gasket Kit, 100V-115V 60 Hz
3	826-1264	Kit—Pump and Gasket
*	807-1995	Pump, Viking 4 GPM
*	809-0514	Cap Screw, 5/16-18 Hex Head
*	809-0194	Washer, Flat 5/16-inch
*	816-0093	Gasket, Pump/Motor
4	810-0278	Gemini Valve w/o Handle
5	810-1067	Flex Line, Oil Return, 11-inch
6	813-0022	Nipple, 1/2-inch x Close (Dual-vat Configuration)
7	813-0062	Elbow, 1/2-inch 90° (Dual-vat Configuration)
8	813-0165	Elbow, 1/2 x 1/2-inch 90° Street
9	813-0253	Nipple, 1/2 x 10-inch (Dual-vat Configuration)
10	813-0331	Elbow, 1/2-inch, With Side Outlet
11	900-2935	Nut, Retainer; Oil Return Valve
12	901-2772	Handle, Valve, Rear Flush Left (Dual-vat Configuration)
13	902-2772	Handle, Valve, Rear Flush Right
14	813-0098	Nipple, 1/2 x 6.5-inch
15	813-0469	Cap, Pipe 1/2-inch

* Not illustrated.

2.10 Filter Pump and Motor Assemblies and Associated Hardware (cont.)

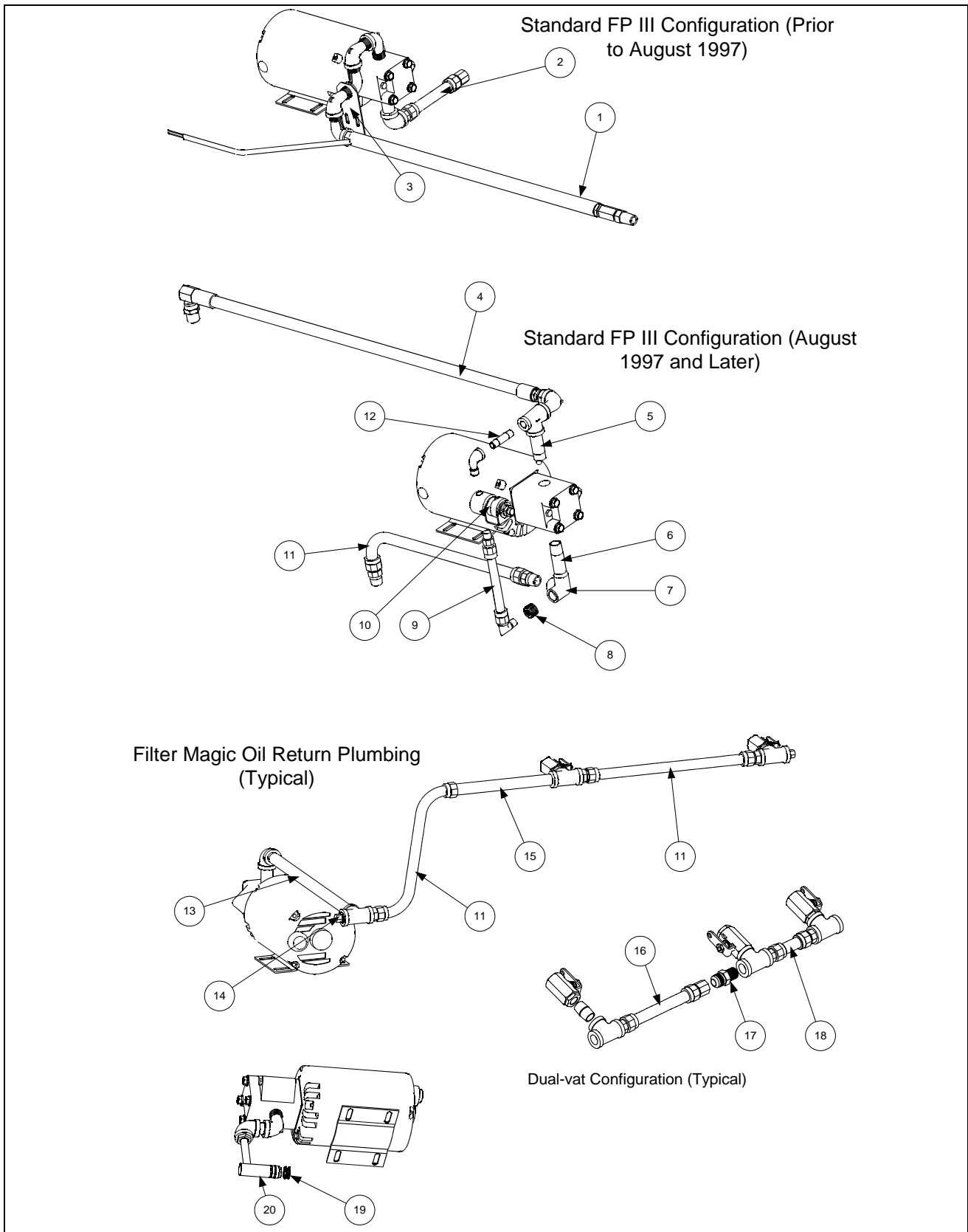

ITEM	PART #	COMPONENT
1		Hose, Heated Oil Return
	810-0945	120VAC
	810-1037	208-250VAC
2	810-1159	Flexline, 7½-inch (19cm) Oil Return
3	900-1958	Support, Oil Return
4	810-1404	Flexline, Oil Return (pump to rear manifold)
5	813-0265	Nipple, ½-inch x 2 ½-inch
6	813-0460	Nipple, ½-inch x 3-inch
7	813-0331	Elbow, ½-inch 3-way
8	813-0304	Bushing, ½-inch to ¼-inch Reducer
9	810-1373	Flexline, Pump Bypass
10	807-2484	Valve, Solenoid Vent
11	810-1057	Flexline, 15½-inch (39.4 cm) Oil Return
12	813-0537	Nipple, ¼-inch x 2-inch
13	813-0368	Nipple, ½-inch x 16-inch
14	813-0156	Pipe Plug, ½-inch
15	813-0275	Nipple, ½-inch x 9-inch
16	810-1488	Flexline, 7-inch (17.8 cm) Oil Return
17	810-1668	Adapter, ½-inch, Female to Female (Used with Item #11, #16 and #18)
18	810-1160	Flexline, 5½-inch (14 cm) Oil Return
19	826-1392	O-Ring (2 required) (Pkg. of 5)
20	823-1356	Disconnect Fitting
*	816-0102	Grommet, Disconnect Fitting
*	900-1472	Diverter, Oil
*	910-1627	Bracket, Disconnect Fitting Support
*	826-1668	Kit, 100V-120V Heater Tape Replacement
*	826-1669	Kit, 108V-250V Heater Tape Replacement
*	811-0746	Aluminum Tape
*	811-0861	Foam Tape
*	811-0208	Spaghetti Insulation

* Not illustrated.

2.10.1 Filter Pump Boxes and Components

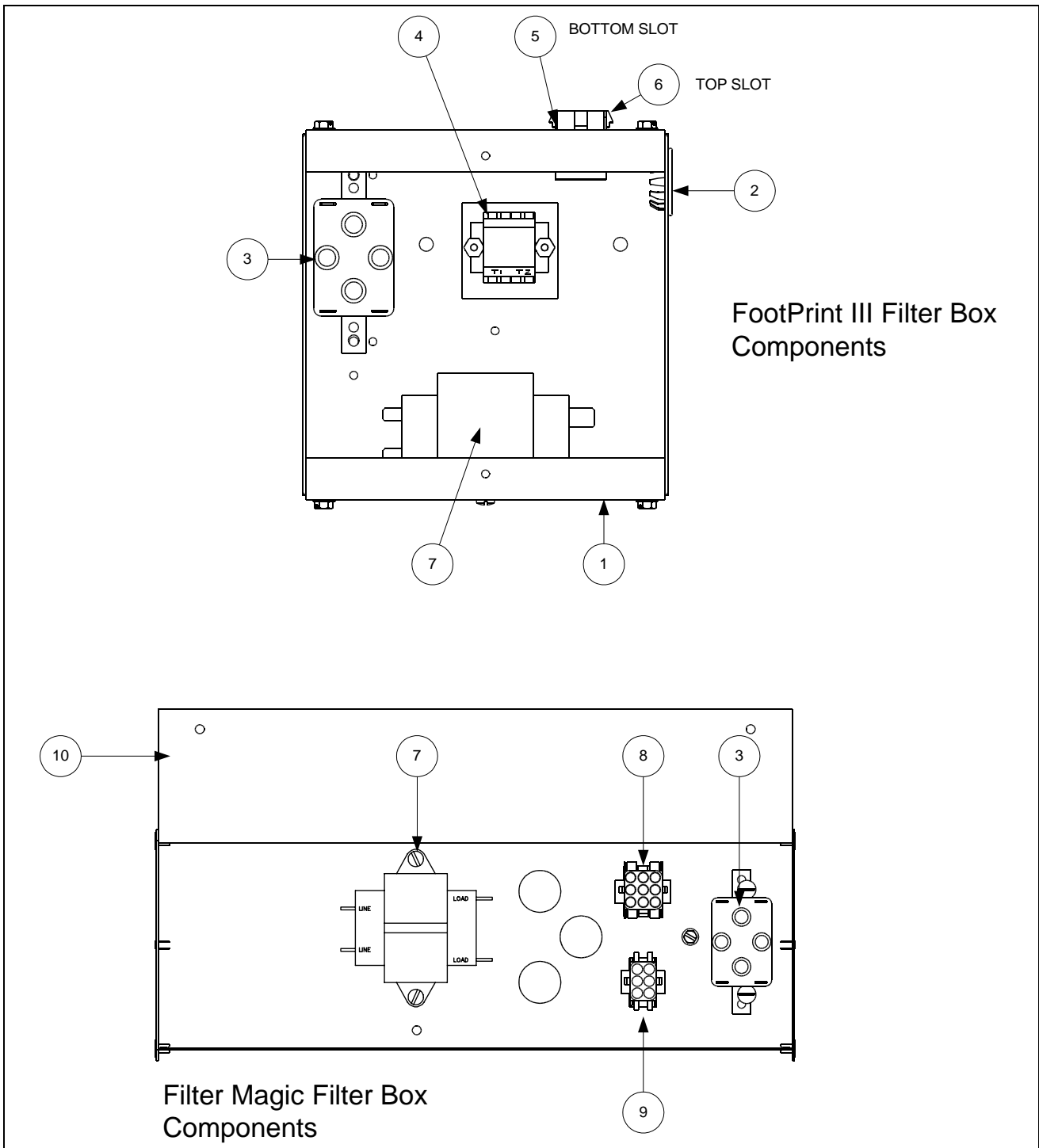

ITEM	PART #	COMPONENT
1	900-5250	Box, Filter FP III
2	810-0044	Plug Button .875, #SS48155 K1110
3		Relay
	807-2434	18A 1/3 HP 24V Coil (before 09/2000)
	807-0012	18A 1/3 HP 24V Coil (after 08/2000)
4	810-1164	Terminal Block, 1 PLC Screwless
*	810-1168	Terminal, Block Screwless End (230V, 50 Hz Filter Magic)
*	807-0276	Block, UL Male 12 Pin Terminal
*	816-0217	Paper, Insulating Terminal Block CE
5	806-7494	Plug Assembly, FPIII Non-Reversing
6	806-8021	Plug Assembly, Filter Box
7		Transformer
	807-0800	120V/24VAC, 50/60 Hz, 50VA
	807-0680	208/240/24VAC, 50/60 Hz, 43VA
	807-1238	105V/24VAC, 50/60 Hz, 50VA
	807-2176	100/120VAC – 12/24V
	807-1999	208/250VAC – 12/24V
8	806-6203	Wiring Assembly, Filter Magic, 9-Pin
9	806-6204	Wiring Assembly, 6-Pin
10	900-2250	Box, Control, Filter Magic
*	900-2251	Box, Control, Filter Magic, Under Cabinet
*	200-0410	Box, Control, Filter Magic Common Electric
*	200-0409	Box, Control, Filter Magic, Common Electric, Under Cabinet
*		Heater Tape Assemblies, FootPrint and Filter Magic
	806-9245SP	120V 25W, 36-inch
	806-5932SP	240V 45W, 36-inch
	806-5933SP	120V 25W, 18-inch
	806-5934SP	240V 25W, 18-inch
*		Heater Tape Assemblies, FootPrint 56-inch
	806-6730SP	100V 40W
	806-6731SP	120V 40W
	806-6732SP	240V 70W
	806-6733SP	250V 70W
*		Harness and Wire Assemblies
	807-2862	FootPrint III Filter Cable (2-pin, 9-pin, and 15-pin connectors)
	WIR0146SP	230V/50Hz Filter Box
	WIR0010SP	120V Standard Filter Control
	WIR0250SP	Filter Control Box
	WIR0394SP	CE Filter Box

* Not illustrated.

2.11 Drain System Components

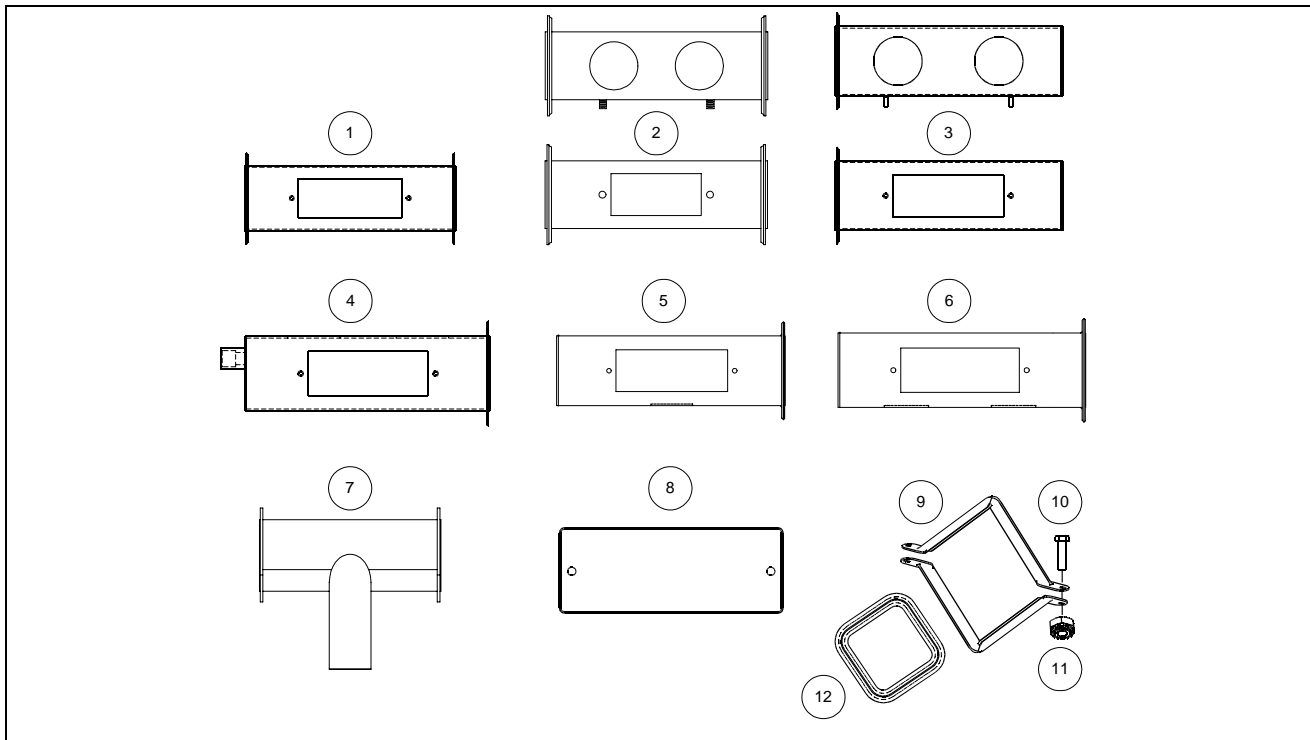

ITEM	PART #	COMPONENT
1	823-0718	Drain Tube, Left End, 2.5 x 8.0-inch
2	823-0725	Drain Tube, Left End, Dual-vat, 2.5 x 8.0-inch
3	823-1551	Drain Tube, Right End, Dual-vat
4	823-2636	Drain Tube, Left End, Dual-vat
*	823-2637	Drain Tube, Left End, Full-vat
5	823-1549	Drain Tube, Right End, Full-vat
6	823-1543	Drain Tube, Right End, Dual-vat
*	823-1508	Drain Tube, Right End, Full Vat 15.5-inch
*	823-0724	Drain Tube, Dual-vat FM 15.5-inch
*	823-0717	Drain Tube, FM Standard Cabinet 15.5-inch
*	823-0720	Elbow, Drain-EF Right FM
*	823-0721	Elbow, Drain-EF Left FM
7	823-2336	Drain, FootPrint
8	826-1348	Cover, Drain Cleanout (Pkg. of 5)
*	816-0021	Gasket, Drain Cover
*	826-1382	Wingnut, Drain Cover (Pkg. of 10)
*	816-0092	Grommet, 1" Drain
*	826-1345	Washer, Drain Nut (Pkg. of 25)
*	809-0347	Drain Nut
9	810-0396	Clamp, 2.5-inch Drain, Filter Magic (Two Required Per Union)
10	826-1375	Screw, 10-32 x 3/4 Hex Trim HD SS (Pkg. of 5)
11	826-1376	Nut, 10-32 Hex (Pkg. of 10)
12	816-0032	Gasket, Square Drain

* Not illustrated.

2.12 Filtration System Components

2.12.1 Oil Return Plumbing Assemblies and Components

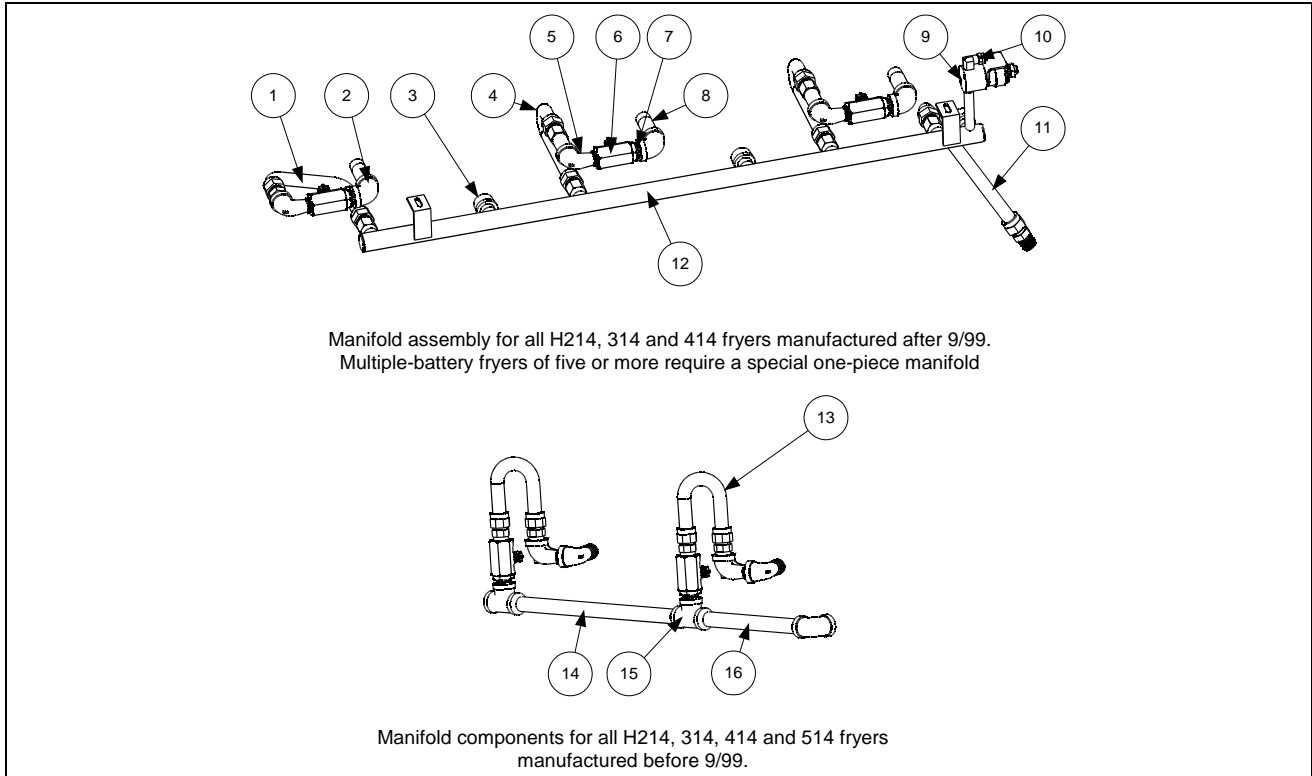

ITEM	PART #	COMPONENT
1	106-0002SP	Flex Line Assembly, With Male/Female Ends
2	813-0062	Elbow, ½-inch 90°
3	813-0469	Cap, Pipe ½-inch
4	106-0054SP	Flex Line Assembly, With Female Ends
5	813-0165	Elbow, Street, ½ x ½-inch 90°
6	810-0278	Gemini Valve, Without Handle
7	813-0022	Nipple, ½-inch Close NPT
8	813-0265	Nipple, ½ x 2.5-inch NPT
9	807-2484	Vent Valve, Solenoid ¼-inch NPT
*	826-1720	Vent Tube, Teflon 3/8-inch OD. X 2-foot
10	810-1372	Fitting, 90°, ¼-inch NPT: 3/8 Tube (includes ferrule and end nut)
11	806-9439SP	Flex Line Assembly, 14-inch with Male/Female Ends
12	810-1517	Manifold, Oil Return, RF H314/17/22
*	810-1516	Manifold, Oil Return, RF H214/17/22
*	810-1518	Manifold, Oil Return, RF H414/17/22
13	810-1067	Flex Line, Oil Return, 11-inch
14	813-0509	Nipple, ½ x 14.5-inch NPT
15	813-0003	Tee, ½ x ½ x ½-inch
16	813-0275	Nipple, ½ x 9-inch NPT
*	813-0093	Nipple, ½ x 4-inch NPT

* Not illustrated.

2.12.2 Power Shower and P.S. Oil Return Manifold Assemblies

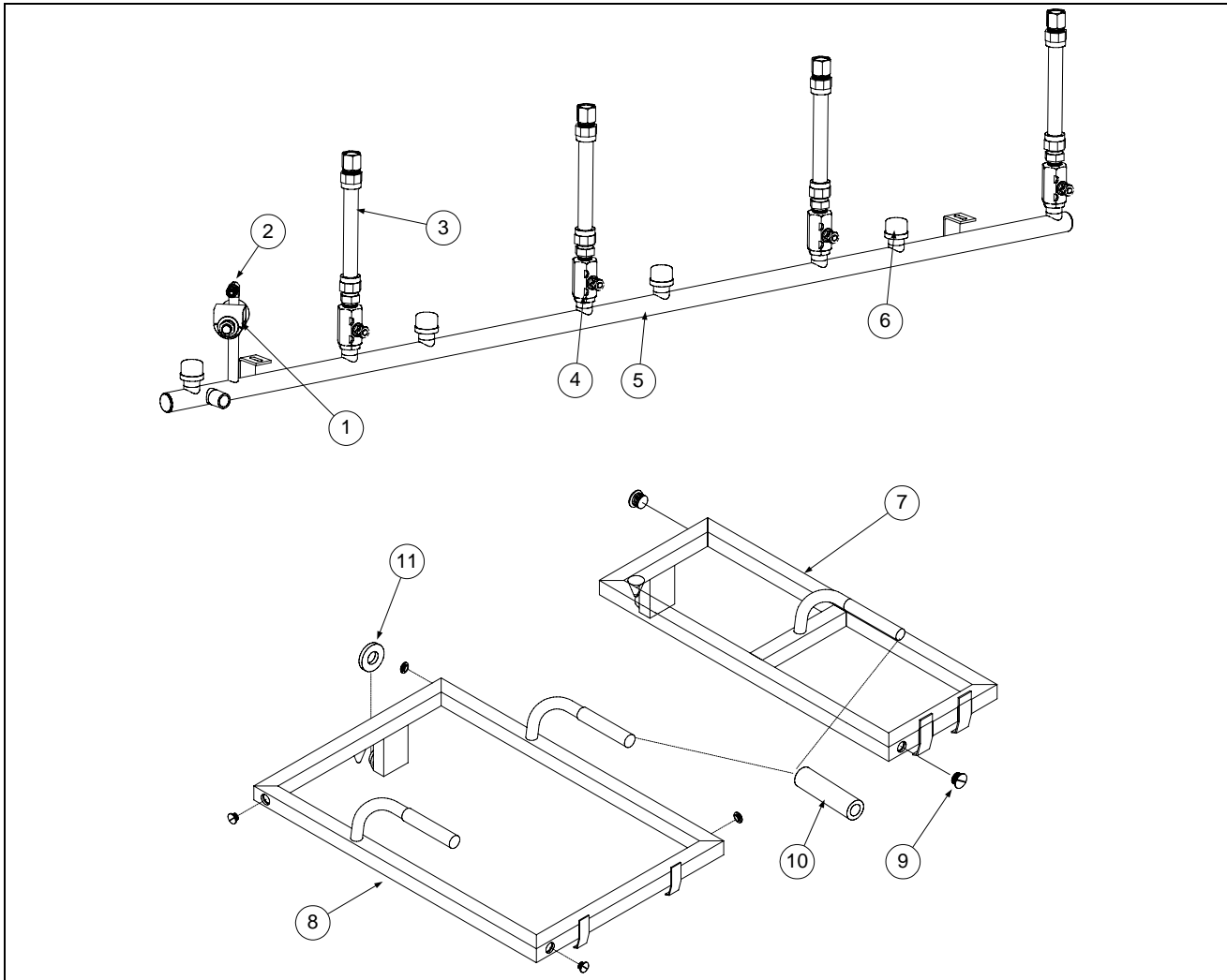

ITEM	PART #	COMPONENT
1	807-2484	Vent Valve, Solenoid ¼ NPT
2	810-1372	Fitting, 90 Degree ¼ NPT X ⅜-inch Tube (includes ferrule and end nut)
*	826-1720	Vent Tube, Teflon 3/8-inch O.D. X 2-foot
3	806-9828	Flexline, with Male/Female Ends
4	810-0278	Valve, Gemini without Handle
5	810-1507	Manifold, H414/17 PS Oil Return
*	810-1505	Manifold, H214/17 PS Oil Return
*	810-1506	Manifold, H314/17 PS Oil Return
6	813-0469	Cap, Pipe ½-inch
7	806-4527SP	Power Shower Assembly, Dual Vat, Complete
8	806-4505SP	Power Shower Assembly, Full Vat, Complete
9	809-0415	Screw, Cleanout
10	814-0001	Grip, Handle
11	816-0026	Seal (Gasket) (2 required)

* Not illustrated.

2.12.3 Rear Flush Oil Return Linkage Assemblies and Components

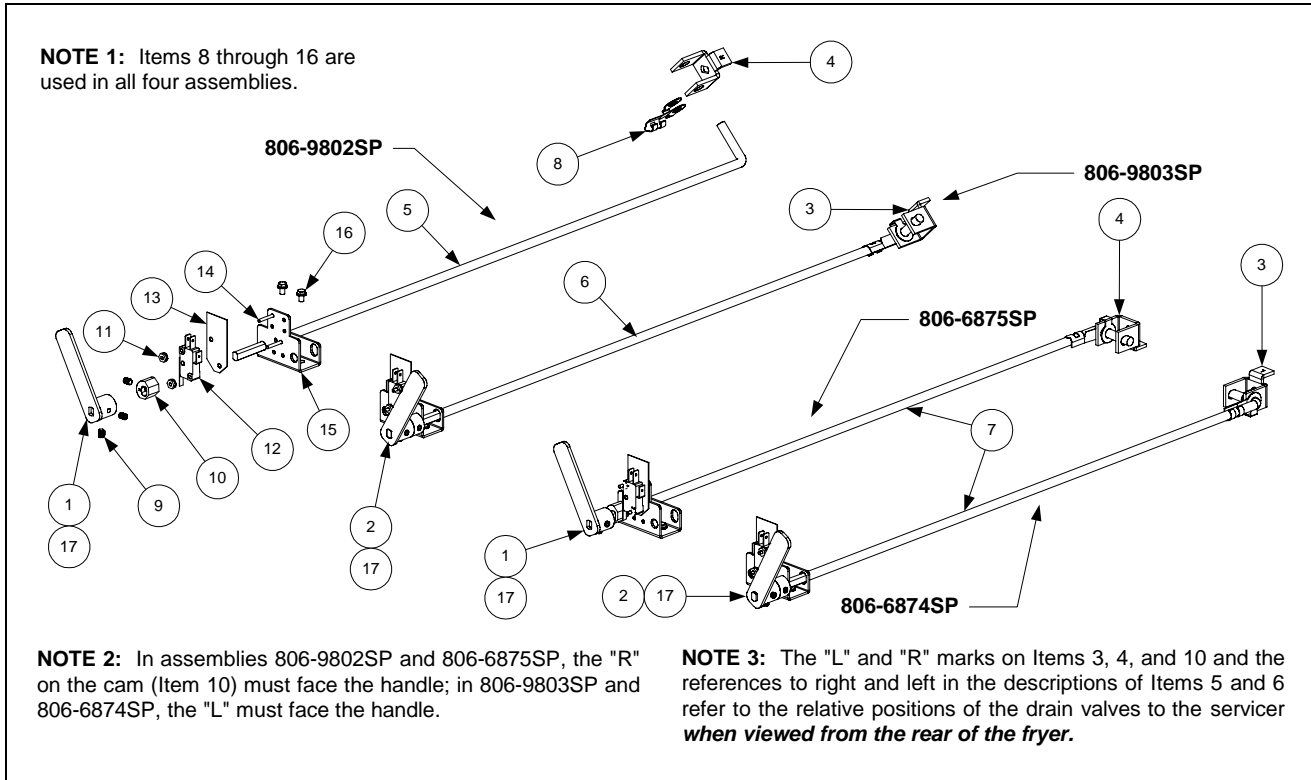

ITEM	PART #	COMPONENT
	806-9802SP	FootPrint III Dual Vat Left Oil Return Linkage Assembly
	806-9803SP	FootPrint III Dual Vat Right or Full Vat Oil Return Linkage Assembly
	806-6875SP	Filter Magic Dual Vat Left Oil Return Linkage Assembly
	806-6874SP	Filter Magic Dual Vat Right or Full Vat Oil Return Linkage Assembly
1	823-2337	Handle, Oil Return, Left
2	823-2338	Handle, Oil Return, Right
3	901-2772	Handle, Rear Flush Valve, Left
4	902-2772	Handle, Rear Flush Valve, Right
5	810-1764	Rod, FootPrint III Oil Return, Right
6	810-1765	Rod, FootPrint III Oil Return, Left
7	810-1180	Shaft, Filter Magic Oil Return
8	809-0601	Clip, $\frac{5}{16}$ -inch Clevis
9	826-1377	Screw, Set 10-32 x $\frac{1}{4}$ (Pkg. of 25)
10	810-1186	Cam, Microswitch
11	826-1366	Nut, 4-40 Hex with External Tooth (Pkg. of 25)
12	807-2103	Microswitch
13	816-0220	Insulation, Microswitch/Bracket
14	826-1359	Screw, 4-40 x $\frac{3}{4}$ -inch Round Head (Pkg. of 25)
15	900-2571	Bracket, Microswitch
16	809-0359	Screw, #8 x $\frac{1}{4}$ -inch Slotted Hex Washer Head
17	816-0047	Sleeve, Red Plastic Valve Handle

2.13 Frypots and Drain Valve Assemblies

Drain Valve Assemblies for Units with Built-in Filtration

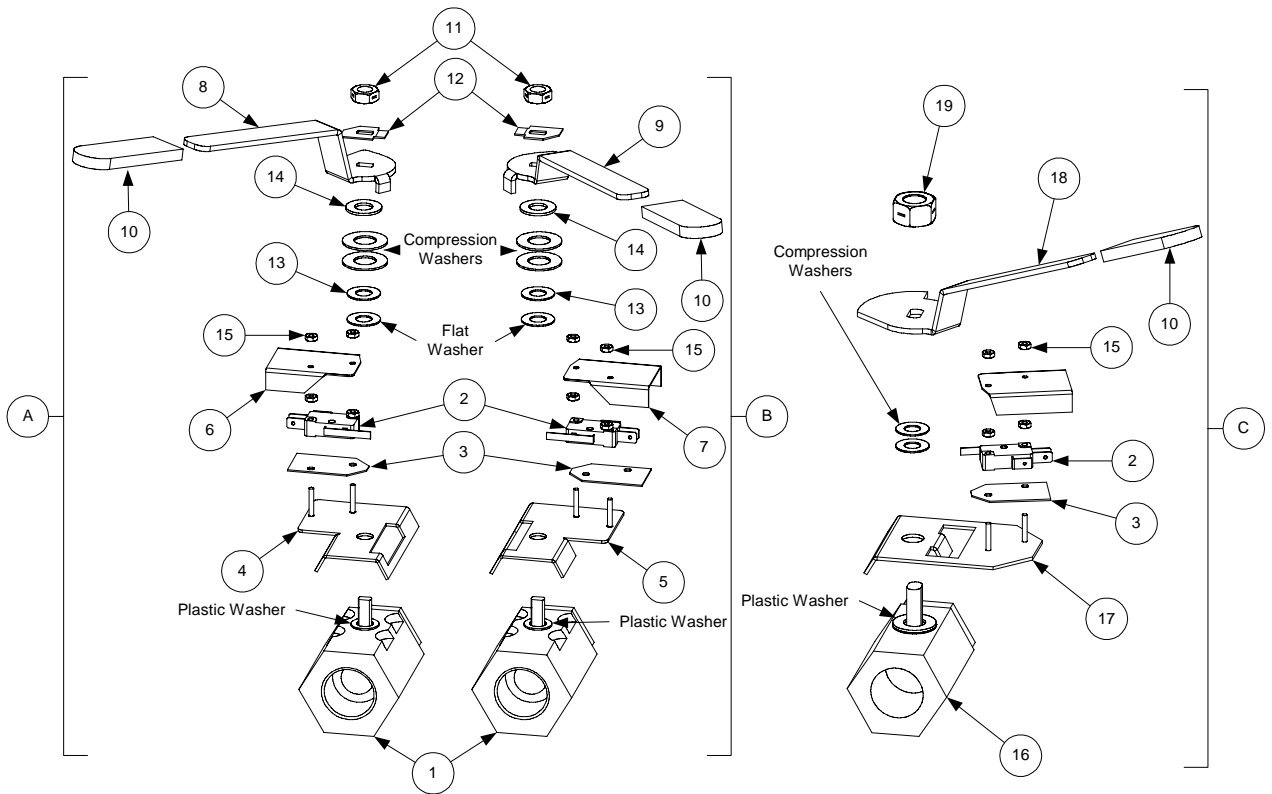

NOTE: Compression washers, flat washers, and plastic washers are integral parts of Items 1 and 16.

Drain Valve Assemblies for Units without Built-in Filtration

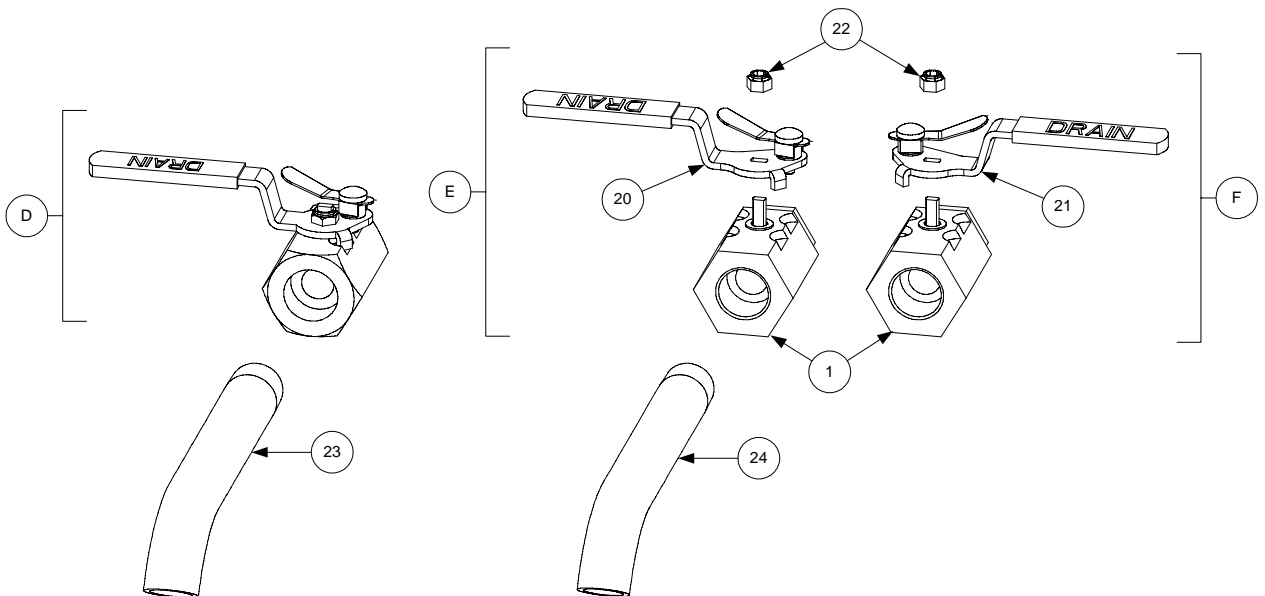

ITEM	PART #	COMPONENT
*		Frypot Assemblies
	823-2450SP	Full-Vat Non-Filter without Insulation
	823-2451SP	Full-Vat Filter without Insulation
	823-2458SP	Dual-Vat Non-Filter without Insulation
	823-2459SP	Dual-Vat Filter without Insulation
	823-0815SP	Dual-Vat Filter without Insulation (for use in single fryers)
	806-8167SP	Full-Vat Non-Filter with Insulation (for use on Triac units)
	806-8168SP	Full-Vat Filter with Insulation (for use on Triac units)
	806-8170SP	Dual-Vat Non-Filter with Insulation (for use on Triac units)
	806-8171SP	Dual-Vat Filter with Insulation (for use on Triac units)
	806-4951SP	Dual-Vat Filter with Insulation (for use in single Triac units)
A	806-7433SP	Valve Assembly, Dual-Vat Left Drain
B	806-7432SP	Valve Assembly, Dual-Vat Right Drain
C	806-7434SP	Valve Assembly, Full-Vat
D	810-1569	Valve Assembly, Full-Vat Non-Filter Drain
E	806-7915SP	Valve Assembly, Dual-Vat Non-Filter Left Drain
F	806-7916SP	Valve Assembly, Dual-Vat Non-Filter Right Drain
1	810-1338	Valve, 1-inch Drain
2	807-2103	Switch, Drain Safety
3	816-0220	Insulation, Drain Safety Switch
4	106-2671	Bracket Assembly, Dual-Vat Left Drain Safety Switch
5	106-2672	Bracket Assembly, Dual-Vat Right Drain Safety Switch
6	901-2348	Cover, Dual-Vat Left Drain Safety Switch
7	902-2348	Cover, Dual-Vat Right Drain Safety Switch
8	201-3916	Handle, Dual-Vat Left Drain Valve
9	200-4304	Handle, Dual-Vat Right Drain Valve
10	814-0047	Sleeve, Red Valve Handle
11	809-0539	Nut, 3/8-16 2-Way Lock
12	900-2934	Retainer, Dual-Vat Drain Valve Nut
13	809-0196	Washer, 3/8-inch Flat
14	810-1165	Washer, Teflon Drain Valve
15	826-1366	Nut, 4-40 Keps Hex (Pkg. of 25)
16	810-1020	Valve, 1 1/4-inch Inlet X 1-inch Outlet
17	806-8137	Bracket Assembly, Full-Vat Drain Safety Switch
18	900-2609	Handle, Full-Vat Drain Valve
19	809-0540	Nut, 1/2-13 2-Way Lock Hex
20	810-1568	Handle, Dual-Vat Left Drain Valve w/Lock Pin
21	810-1567	Handle, Dual-Vat Right Drain Valve w/Lock Pin
22	809-0589	Nut, 1/2-13 2-Way Lock Hex
23	812-1226SP	Extension, Full-Vat Drain Valve (1 1/4-inch)
24	812-1227	Extension, Dual-Vat Drain Valve (1-inch)

* Not illustrated.

2.14 High-Limit Thermostat and Related Components

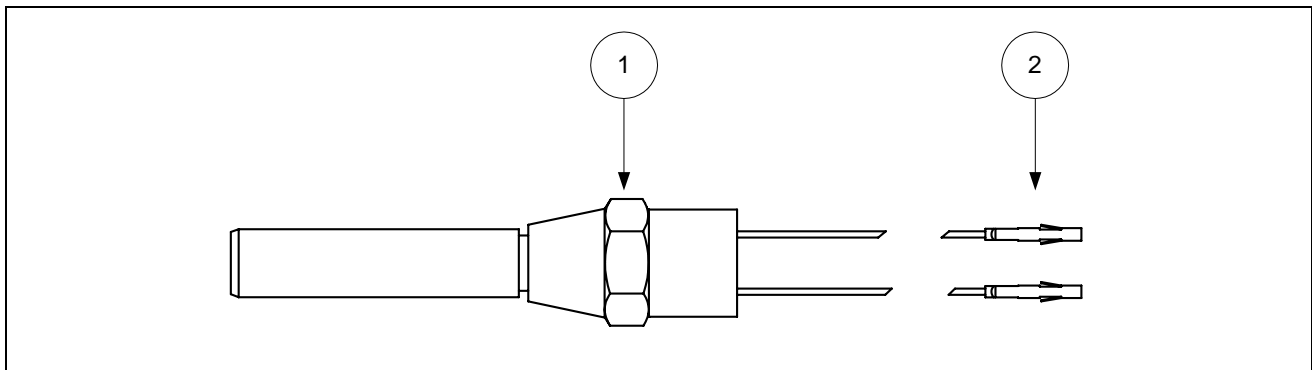

ITEM	PART #	COMPONENT
1		High-Limit Thermostat
	806-7543	Non-CE Full-vat (Color-Coded Black)
	806-8035	Non-CE Dual-vat (Color-Coded Red)
	806-8132	CE other than 22kW (Color-Coded Yellow)
	806-8536	CE 22kW
2	826-1332	Terminal, Female Disconnect Pin (Pkg. of 25)

* Not illustrated.

THIS PAGE INTENTIONALLY LEFT BLANK



FRYMASTER
8700 LINE AVENUE, SHREVEPORT, LA 71106-6800

800-551-8633
318-865-1711

WWW.FRYMASTER.COM

EMAIL: FRYSERVICE@WELBILT.COM



Welbilt offers fully-integrated kitchen systems and our products are backed by KitchenCare® aftermarket parts and service. Welbilt's portfolio of award-winning brands includes Cleveland™, Convotharm®, Crem®, Delfield®, Frymaster®, Garland®, Kolpak®, Lincoln®, Merco®, Merrychef® and Multiplex®.

Bringing innovation to the table • welbilt.com

©2022 Welbilt Inc. except where explicitly stated otherwise. All rights reserved. Continuing product improvement may necessitate change of specifications without notice.

Part Number FRY_SP_8195794 09/2022