



Ultimate Electric Series Fryers Service & Parts Manual



Frymaster/Dean, a member of the Commercial Food Equipment Service Association, recommends using CFESA Certified Technicians.

24-Hour Service Hotline 1-800-551-8633

Price: \$28.00

**819-5981
JUNE 2003**

Please read all sections of this manual and retain for future reference.

NOTICE

This appliance is intended for professional use only and is to be operated by qualified personnel only. A Frymaster/Dean Factory Authorized Service Center (FASC) or other qualified professional should perform installation, maintenance, and repairs. Installation, maintenance, or repairs by unqualified personnel may void the manufacturer's warranty. See Chapter 1 of this manual for definitions of qualified personnel.

NOTICE

This equipment must be installed in accordance with the appropriate national and local codes of the country and/or region in which the appliance is installed.

NOTICE TO U.S. CUSTOMERS

This equipment must be installed in accordance with the appropriate national and local codes of the country and/or region in which the appliance is installed.

NOTICE

Drawings and photos used in this manual are intended to illustrate operational, cleaning and technical procedures and may not conform to onsite management operational procedures.

NOTICE TO OWNERS OF UNITS EQUIPPED WITH COMPUTERS

U.S.

This device complies with Part 15 of the FCC rules. Operation is subject to the following two conditions: 1) This device may not cause harmful interference, and 2) This device must accept any interference received, including interference that may cause undesired operation. While this device is a verified Class A device, it has been shown to meet Class B limits.

CANADA

This digital apparatus does not exceed the Class A or B limits for radio noise emissions as set out by the ICES-003 standard of the Canadian Department of Communications.

Cet appareil numérique n'émet pas de bruits radioélectriques dépassant les limites de classe A et B prescrites dans la norme NMB-003 édictée par le Ministre des Communications du Canada.

 DANGER

Improper installation, adjustment, maintenance or service, and unauthorized alterations or modifications can cause property damage, injury, or death. Read the installation, operating and service instructions thoroughly before installing or servicing this equipment.

 **DANGER**

The front ledge of the fryer is not a step. Do not stand on the fryer. Serious injury can result from slips or contact with the hot oil.

 **DANGER**

Do not store or use gasoline or other flammable vapors and liquids in the vicinity of this or any other appliance.

 **DANGER**

The crumb tray in fryers equipped with a filter system must be emptied into a fireproof container at the end of frying operations each day. Some food particles can spontaneously combust if left soaking in certain shortening material. Additional information can be obtained in the filtration manual included with the system.

 **WARNING**

No structural material on the fryer should be altered or removed to accommodate placement of the fryer under a hood. Questions? Call the Frymaster/Dean Service Hotline at 1-800-551-8633.

 **WARNING**

Do not bang fry baskets or other utensils on the fryer's joiner strip. The strip is present to seal the joint between the frypot. Banging fry baskets on the strip to dislodge shortening will distort the strip, adversely affecting its fit. It is designed for a tight fit and should only be removed for cleaning.

NOTICE

IF, DURING THE WARRANTY PERIOD, THE CUSTOMER USES A PART FOR THIS ENODIS EQUIPMENT OTHER THAN AN UNMODIFIED NEW OR RECYCLED PART PURCHASED DIRECTLY FROM FRYMASTER/DEAN, OR ANY OF ITS AUTHORIZED SERVICE CENTERS, AND/OR THE PART BEING USED IS MODIFIED FROM ITS ORIGINAL CONFIGURATION, THIS WARRANTY WILL BE VOID. FURTHER, FRYMASTER/DEAN AND ITS AFFILIATES WILL NOT BE LIABLE FOR ANY CLAIMS, DAMAGES OR EXPENSES INCURRED BY THE CUSTOMER WHICH ARISE DIRECTLY OR INDIRECTLY, IN WHOLE OR IN PART, DUE TO THE INSTALLATION OF ANY MODIFIED PART AND/OR PART RECEIVED FROM AN UNAUTHORIZED SERVICE CENTER.



Ultimate Electric Series Fryers Service & Parts Manual

TABLE OF CONTENTS

	Page #
1. SERVICE PROCEDURES	1-1
1.1 General	1-1
1.2 Replace Computer/Controller	1-1
1.3 Replace Interface Board	1-2
1.4 Replace Transformer	1-3
1.5 Replace Temperature Probe	1-3
1.6 Replace Heating Element	1-6
1.7 Replace High-Limit	1-9
1.8 Replace Frypot	1-10
1.9 Replace Contactor (Latching or Heating)	1-11
1.10 Built-in Filter System Service Procedures	1-11
1.11 Basket Lift Service Procedures	1-13
1.12 Electric Interface Board Diagnostic Chart	1-17
1.13 Probe Resistance Chart	1-18
1.14 Element Wattage/Amperage Calculation Charts	1-18
1.15 Wiring Diagrams, Main	1-19
1.15.1 480V 18UE and EH1721	1-19
1.15.2 208V 18UE and EH1721	1-20
1.15.3 KSCFH218E	1-21
1.15.4 BIH1721	1-22
1.16 Wiring Diagrams, Basket Lifts	1-23
1.16.1 Modular Basket Lifts	1-23
1.16.2 Bell Crank Style Basket Lifts	1-23
1.17 Wiring Diagrams, Built-in Filtration	1-24
1.17.1 480V Systems	1-25
1.17.2 208V Systems	1-26
1.17.3 115/230V KFC Systems	1-27



Ultimate Electric Series Fryers Service & Parts Manual

TABLE OF CONTENTS (CONT.)

	Page #
2. PARTS LIST	2-1
2.1 Accessories	2-1
2.2 Basket Lift Assembly (Modular) and Related Components	2-2
2.3 Cabinetry and Related Components	2-5
2.3.1 EH1721 & 18UE Electric	2-5
2.3.2 KFC18E Electric	2-8
2.3.3 Door Components – Spring-Loaded Door Pins	2-10
2.3.4 Top Caps and Tilt Housing Components	2-11
2.4 Computer and Related Components	2-12
2.5 Contactor/Wireway Box and Related Components	2-14
2.6 Filter Pan and Related Components	2-16
2.6.1 Under Fryer Filter (UFF) – UFF 80 (100 Lb Capacity)	2-16
2.6.2 Under Fryer Filter (UFF) – KFC18E Only	2-17
2.6.3 Under Fryer Filter (UFF) – Filter-Leaf/Suction Tube Assembly	2-19
2.6.4 Single Under Fryer Filter (SUFF) – BIH1721 & 18UE	2-20
2.7 Frypot and Drain Valve Components	2-21
2.8 Oil Drain Flush Components	2-22
2.9 Oil Drain Manifold Components	2-23
2.10 Oil Return Manifold, Motor and Pump Components	2-24
2.11 Oil Return Line Assemblies	2-27
2.12 Probes, High-Limits, Elements and Related Components	2-29
2.13 Tilt Safety Switch Components	2-32

ULTIMATE ELECTRIC SERIES FRYERS

CHAPTER 1: SERVICE PROCEDURES

1.1 General

Before performing any maintenance on your Frymaster/Dean Ultimate Electric fryer, you must disconnect the electrical power supply.

When electrical wires are disconnected, it is recommended that they be marked in such a way as to facilitate reassembly.

⚠ DANGER

Hot cooking oil or shortening will cause severe burns. Never attempt to move this appliance when filled with hot cooking oil or shortening, or to transfer hot cooking oil or shortening from one container to another.

⚠ DANGER

This equipment should be unplugged when servicing, except when electrical circuit tests are required. Use extreme care when performing such tests.

This appliance may have more than one electrical power supply connection point. Disconnect all power cords before servicing.

Inspection, testing and repair of electrical components should be performed by an authorized service agent only.

1.2 Replace Computer/Controller

1. Unscrew and remove two control panel screws on control panel front. Swing the panel open from the top.
2. Unplug wiring harness at plug on back of controller (arrow). Unplug controller ground wire from controller (circle).
3. Remove the control panel/controller by lifting the assembly from the hinged slots in the control-panel frame.
4. Reverse procedures to install new controller.

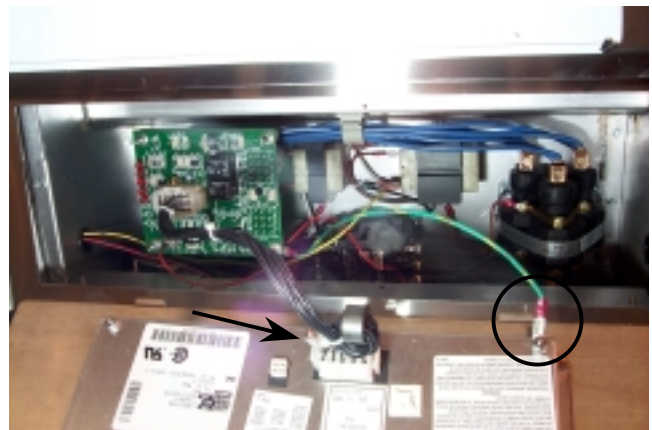

Wire harness/connector and ground wire on controller back.

ULTIMATE ELECTRIC SERIES FRYERS

CHAPTER 1: SERVICE PROCEDURES

1.3 Replace Interface Board

1. Unplug all power cords. Perform Procedure 1.2, Steps 1-4, Replace Computer/Controller.
2. Unplug wire harness from the interface board (arrow). Remove all wiring from the terminals of the interface board, ensuring that each wire is marked for reattachment.

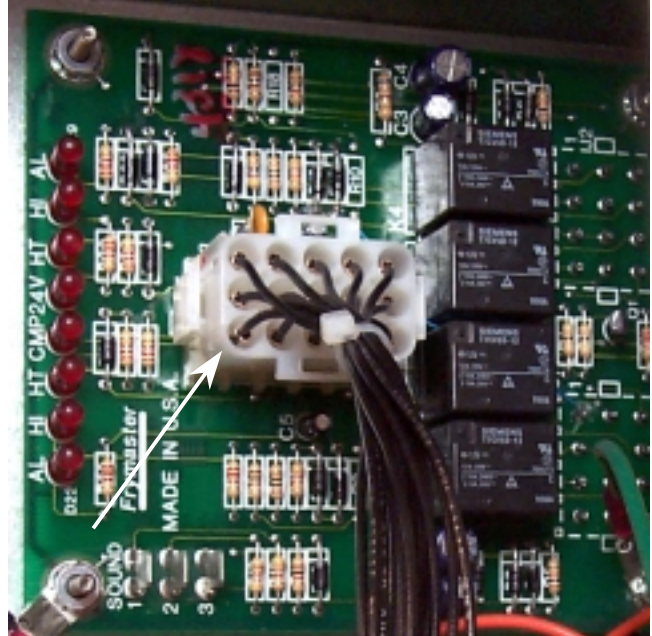

Wire harness/connector.

3. Remove the nuts from each corner of the interface board and slide the board from the studs. Unplug connectors J1 and J2, mark and unplug all other wiring on rear of the interface board. Ensure that standoffs remain in place on studs, prior to installing new interface board. Install the new interface board by reversing the previous procedures. Ensure that wire harnesses are connected to back of interface board prior to securing interface board. Also, ensure that wiring and wire harnesses are connected to the proper terminals.

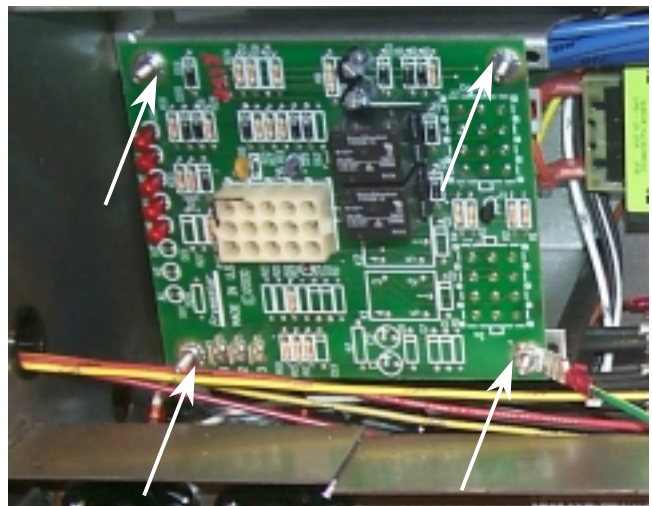

Nuts securing interface board (arrows).

ULTIMATE ELECTRIC SERIES FRYERS

CHAPTER 1: SERVICE PROCEDURES

1.4 Replace Transformer

1. Unplug all power cords. Perform Procedure 1.2, Steps 1-4, Replace Computer/Controller.
2. Remove all wiring from the terminals of the transformer to be replaced (arrows).
3. Remove the screws that secure the transformer to the component box.
4. Install the new transformer by reversing the preceding procedures. Make sure you reconnect the wiring to the proper terminals and the harnesses to the correct connectors.

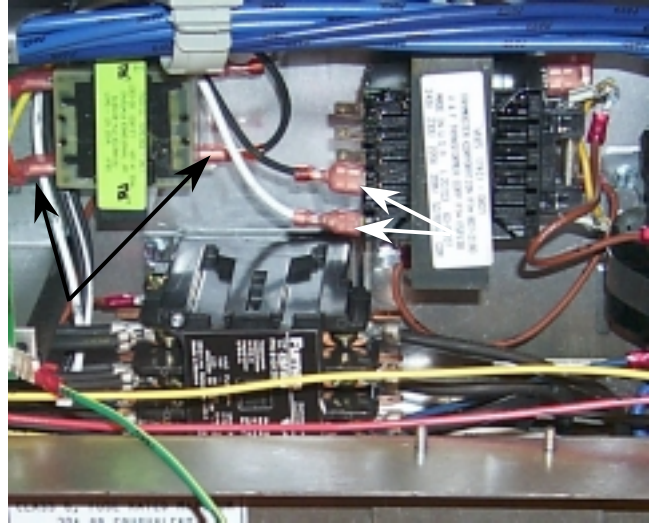

Mark and disconnect wiring from the transformer being replaced.

1.5 Replace Temperature Probe

1. Unplug fryer from the electrical source.
2. Drain the cooking oil from the frypot.
3. Remove the fryer from the exhaust hood to gain access to the rear of the fryer.
4. Remove the screws from the back cover(s). Set the cover(s) and screws aside.
5. After removing back(s), remove two remaining screws securing the tilt housing cover (arrows). Remove the tilt housing.

Note: Early production model shown. Current production units have a one-piece back panel (remove all screws securing back panel). Older units have a three-piece back panel.

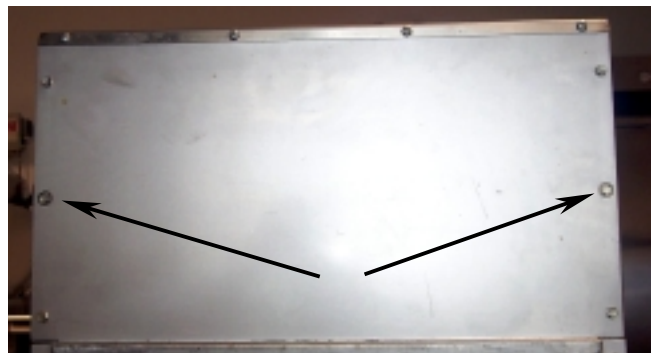

Screws securing back cover and tilt housing. Remove two tilt-housing screws (arrows) after removing all other screws and back panel(s).

ULTIMATE ELECTRIC SERIES FRYERS

CHAPTER 1: SERVICE PROCEDURES

1.5 Replace Temperature Probe (cont.)

6. Disconnect the wire harness containing the probe wiring (arrows). It may be necessary to remove the wire ties.
7. Use a pin-pusher (P/N 806-4855 or P/N 807-0928—see Section 1.7) to remove the red and white probe wires from the connector. Note probe pin location in plug. Pull the probe wires out of the insulation.

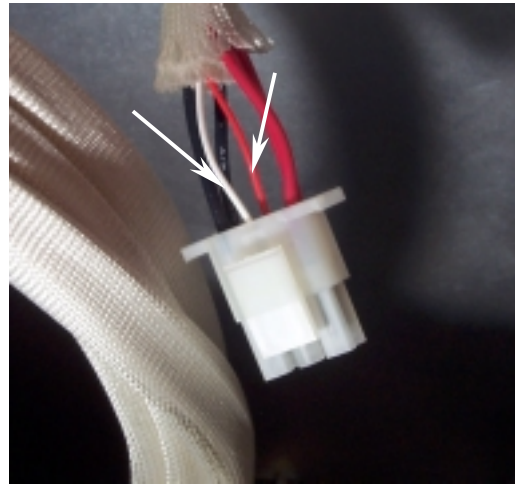

Use a pin-pusher to remove probe wires from connector (arrows).

8. Remove the screw(s) securing the probe bracket to the element. Remove the metal wraps securing the probe to the element.

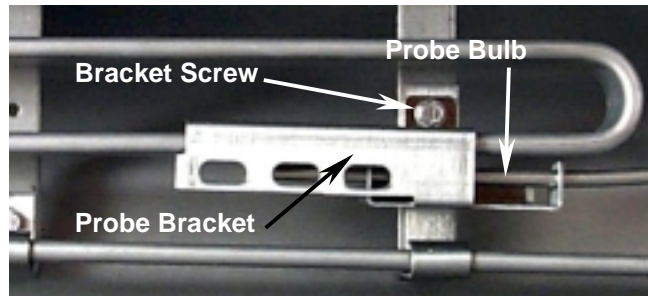

Remove probe bracket screw and bracket to remove probe.

9. Remove the probe bracket and the securing components from the probe bulb and element. Thread the probe wire through the hole (arrow) in the tilt plate assembly and remove the probe.

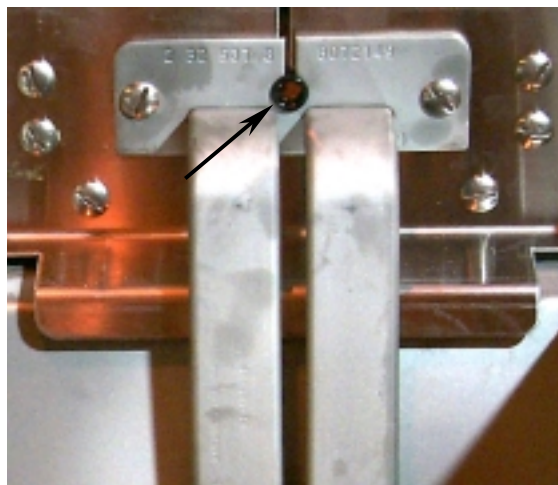

Pull old probe wire through grommet to remove probe.

ULTIMATE ELECTRIC SERIES FRYERS

CHAPTER 1: SERVICE PROCEDURES

1.5 Replace Temperature Probe (cont.)

10. Thread the new probe wire through the hole in tilt plate. Place the new temperature probe assembly onto the element and secure with the bracket and screws removed earlier. Clip the probe onto the rear of the element (arrow) in two places. The temperature probe assembly should be oriented in the same manner as the probe being replaced.

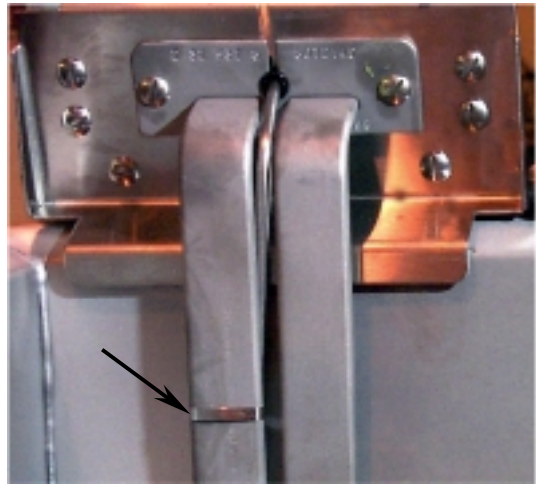

Secure probe bulb to the element back in two places with metal wire wrap (arrow).

11. Thread the probe wires into the harness insulation. Note the pin positions and insert pins in the connector. Reconnect the harness and secure with a wire-tie.

12. Lower the element into the frypot with the lift handle.

13. Place the tilt housing cover over the tilt housing assembly and secure with screws. Slightly raising the elements will facilitate tilt-housing installation.

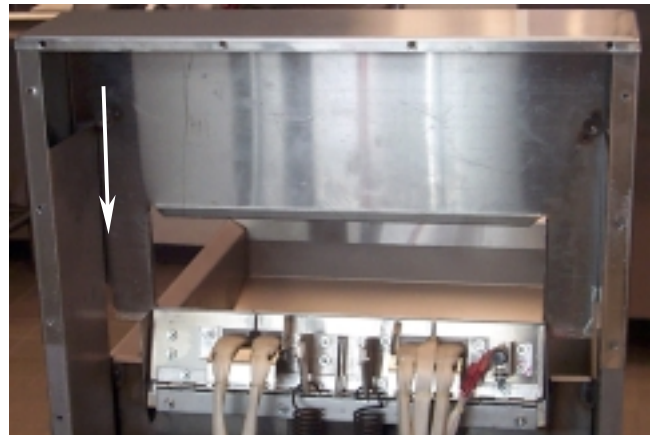

Install tilt housing and cabinet backs after probe installation is complete.

14. Install back cover(s) and secure with screws

ULTIMATE ELECTRIC SERIES FRYERS

CHAPTER 1: SERVICE PROCEDURES

1.6 Replace Heating Element

1. Perform Procedure 1.5, Replace Temperature Probe, Steps 1-7.

2. Unplug the element connectors for the element being removed (right element- 6-pin harness connector; left element- 9-pin harness connector). Remove the element wires from the connector. Press down on either side of the connector while pulling up on the top portion. The connector will open from the top. Note wiring configuration in connector before removing element wire pins. Pull all wires from the connector.

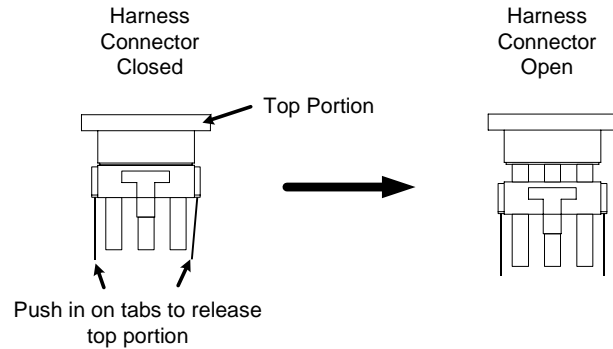

3. Remove the screws securing the temperature probe bracket from the element. Remove the probe clamp (metal wire-wrap). Set the temperature probe and probe-securing components aside.

NOTE: Temperature probe removal is not required if the left element is being replaced.

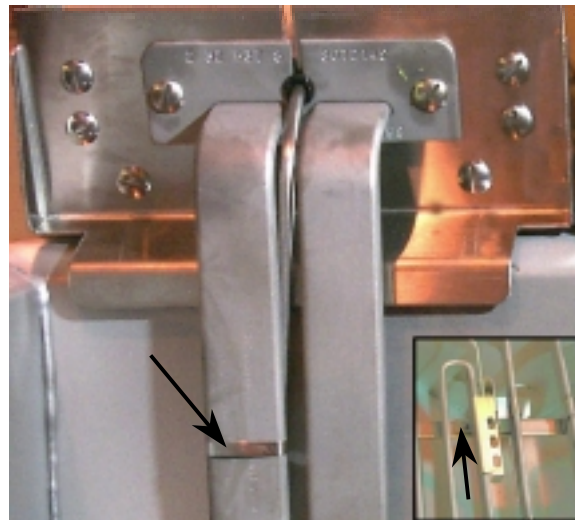

Remove metal wire wrap (arrow), and screws securing probe bracket to element (inset, arrow).

4. Disconnect the element springs from the tilt brackets.

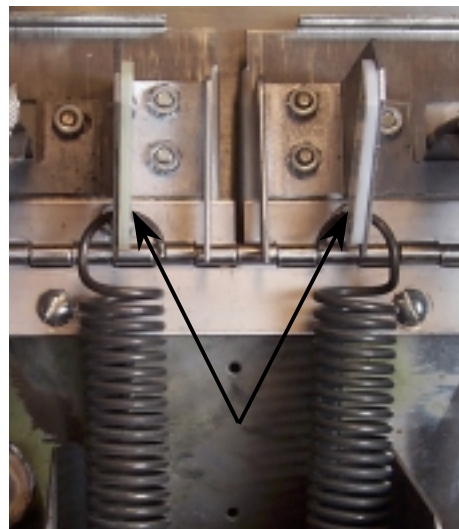

Disconnect element springs here.

ULTIMATE ELECTRIC SERIES FRYERS

CHAPTER 1: SERVICE PROCEDURES

1.6 Replace Heating Element (cont.)

5. Remove the element clamps and hardware before removing mounting-screws and nuts on the defective element. Remove all wire-ties securing element wiring, and then remove element from frypot.
6. Install the replacement element in the frypot and secure with the mounting hardware removed in Step 5.
7. Reinstall the temperature probe and probe-bracket components onto the replacement element.
8. Route the element leads (terminals) to the rear of the fryer. Ensure the element-harness insulation is in place prior to installing connectors.

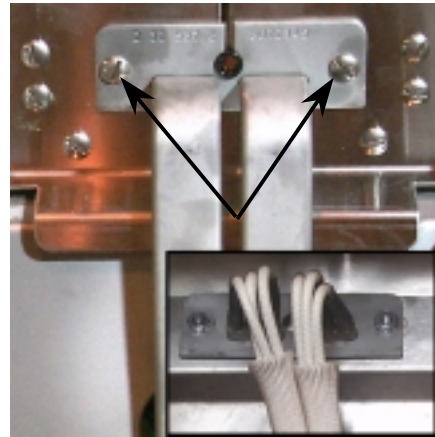

Element mounting screws on tilt-plate front. (Inset: element mounting plate on tilt-plate back.)



Ensure element wire insulation is installed and that the wires are properly routed to prevent wire chafing.

9. Secure element wiring with wire-ties.

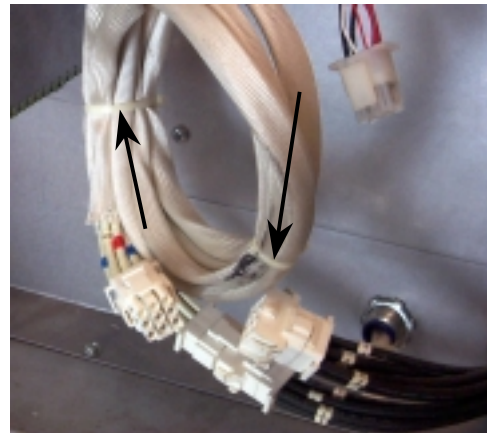

Use wire-ties (arrows) to secure element wiring.

ULTIMATE ELECTRIC SERIES FRYERS

CHAPTER 1: SERVICE PROCEDURES

1.6 Replace Heating Element (cont.)

10. When replacing the left element (as viewed from the rear of the fryer), use the 9-pin connector, inserting the leads from the replacement element. Ensure the pin numbers match the numbers of the defective element wires. When all pin terminals have been fully inserted, close the connector by sliding the halves together until the tabs snap back into place (reverse procedure in this section, Step 2). Check wire numbers to ensure correct wiring of the replacement element.

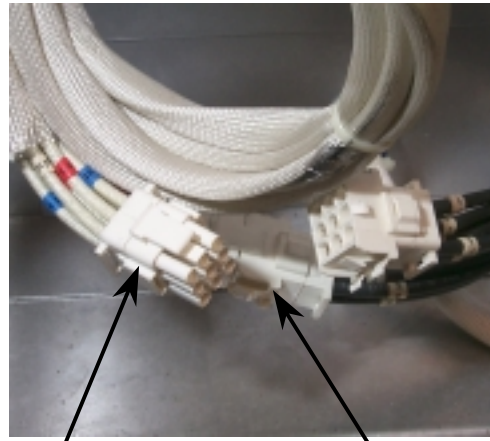

Left Element—
9-Pin Connector

Right Element—
6-Pin Connector

When replacing the right element (as viewed from the rear of the fryer), follow the above procedure, inserting pin terminals into the corresponding holes in the 6-pin connector.

11. Connect the connectors, ensuring the latches lock in place (arrow).
12. Install the temperature probe wires (marked for re-assembly) in the corresponding pin locations.

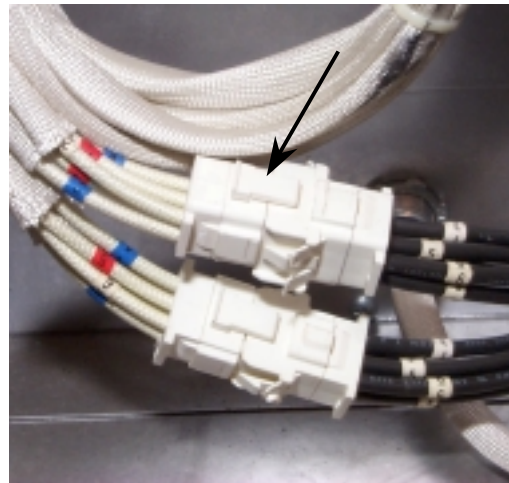

Ensure the connection is complete and the latches (arrow) are locked in place.

13. Reconnect the element springs. Older models have turnbuckles (arrow) to allow adjustment of the spring tension.
14. Place the tilt housing cover over the tilt housing assembly and secure with screws.
15. Install back covers and secure with screws.
16. Position fryer under exhaust hood.



Older units have turnbuckles to adjust spring tension. Current production models are not adjustable.

ULTIMATE ELECTRIC SERIES FRYERS

CHAPTER 1: SERVICE PROCEDURES

1.7 Replace High-Limit

1. Perform Procedure 1.5, Replace Temperature Probe, Steps 1-4.
2. Disconnect the wire harness containing the high-limit wires.
3. Use a pin-pusher (P/N [806-4855](#) or P/N 807-0928) to remove the two high-limit wires from the wire harness connector (arrows). Note pin location in connector before removing wires.
4. Remove the high-limit from the frypot using an open-end wrench or other suitable tool.
5. Apply Loc-Tite PST 567 sealant to the replacement high-limit threads.
6. Screw the replacement high-limit into the frypot and tighten to 170-180 inch-pounds torque. **DO NOT OVERTIGHTEN.**
7. Insert the replacement high-limit wires into the connector, ensuring each wire is in the correct hole..
8. Reconnect the high-limit wire-harness connector.
9. Install and secure the back cover(s).
10. Return fryer to operation.

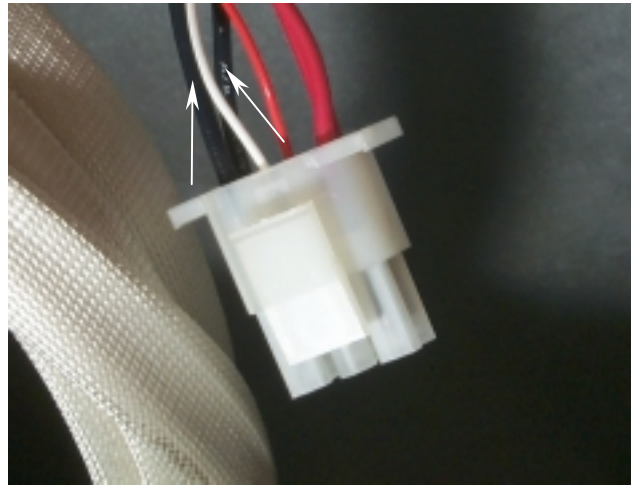

Using a pin-pusher, remove two high-limit wires (arrows) from connector.



Pin Pusher— P/N [807-0928](#)



Place wrench here when removing and installing high-limit.

ULTIMATE ELECTRIC SERIES FRYERS

CHAPTER 1: SERVICE PROCEDURES

1.8 Replace Frypot

1. Perform Procedure 1.5, Replace Temperature Probe, Steps 1-7.
2. Perform Procedure 1.2, Replace Computer/Controller, Steps 1-3.
3. Perform Procedure 1.7, Replace High-Limit, Steps 1-4.
4. Disconnect the element wire harnesses.
5. Remove the screws securing the capping piece from the fryer. Remove the capping piece and set aside.
6. If the fryer has a built-in filtration system, remove all the plumbing from the frypot, including oil-return and drain plumbing.
7. Remove the screws securing the frypot to the front frame of the fryer.
8. Carefully lift the frypot from the cabinet.
9. Remove the drain valve from the old frypot and install on the new frypot.
10. Apply Loc-Tite Sealant PST 567 to the high-limit threads. Install high-limit into the new frypot.
11. Disconnect the tilt plate springs from the old frypot.
12. Remove the securing screws from the tilt plate. Lift the tilt plate/heating element assembly from the old frypot and install on the new frypot.
13. Follow the preceding steps in reverse to install the new frypot into the fryer.
14. NOTE: Apply Loc-Tite Sealant PST 567 to all pipefittings prior to installation.

ULTIMATE ELECTRIC SERIES FRYERS

CHAPTER 1: SERVICE PROCEDURES

1.9 Replace Contactor (Latching or Heating)

1. Perform Procedure 1.2, Replace Computer/Controller, Steps 1-3.
2. Identify faulty contactor. Remove all wiring connected to the contactor terminals (circles) inside the component box. Tape wire-pairs together and mark each wire-set or wire for reassembly.
3. Remove contactor-mounting screws (arrow) and remove the contactor.
4. Install the new contactor and connect the wiring removed in Step 2.

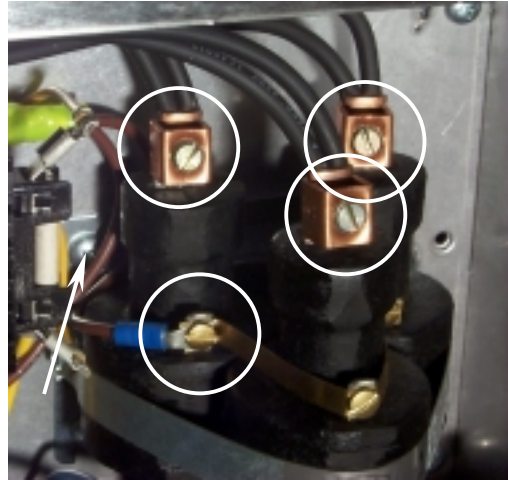

Remove contactor-mounting screws after removing all wiring from the contactor (circles).

1.10 Built-in Filter System Service Procedures

Troubleshooting Built-In Filtration Systems

One of the most common errors is placing the filter paper on the bottom of the filter pan rather than over the filter screen.

⚠ CAUTION

Ensure that the paper support screen is in place prior to filter paper placement and filter pump operation. Improper screen placement is the major cause of filter system malfunction.

Whenever the complaint is "the pump is running, but no oil is being filtered", check the installation of the filter paper, and ensure that the correct size is being used. While you are checking the filter paper, verify that the O-rings on the supply line connection are present and in good condition. Missing or worn O-rings allow the pump to take in air, decreasing its efficiency. In addition, oil leaks into the fryer and on the floor each time a frypot is filtered.

ULTIMATE ELECTRIC SERIES FRYERS

CHAPTER 1: SERVICE PROCEDURES

1.10 Built-in Filter System Service Procedures (cont.)

If the pump motor overheats, a circuit breaker will trip and the motor will not start until the breaker is reset. If the pump motor does not start, press the white reset button located under the component box, inside the cabinet.

If the pump starts after resetting the breaker, then something is causing the motor to overheat. A major cause of overheating is when several frypots are filtered sequentially, thus overheating the pump and motor. Allow the pump motor to cool at least 30 minutes before resuming operation, and allow time for the motor to cool between sequential frypot filtering.

Pump overheating can be caused by:

- Solidified shortening in the pan or filter lines,
- or
- Attempting to filter unheated oil or shortening.

Cold oil and shortening are more viscous, causing the pump motor to load up and overheat. Always filter with the oil or shortening at operating temperature [$\sim 350^{\circ}\text{F}$ (177°C)].

If the motor runs but the pump does not, there is a blockage in the pump. Incorrectly sized or installed paper/pads will allow food particles and sediment to pass through the filter pan and into the pump. When sediment enters the pump, the gears bind, causing the motor to overload, again tripping the thermal overload. Shortening that has solidified in the pump will also cause it to seize, with the same result.

A pump seized by debris or hard shortening must be disassembled, cleaned, and then reassembled before continuing use. Use the following procedure:

1. Disconnect power to the filter system.
2. Remove the front cover of the pump to access the gears inside (see illustration below- 8-GPM pump shown), if the pump is accessible while still inside the cabinet.

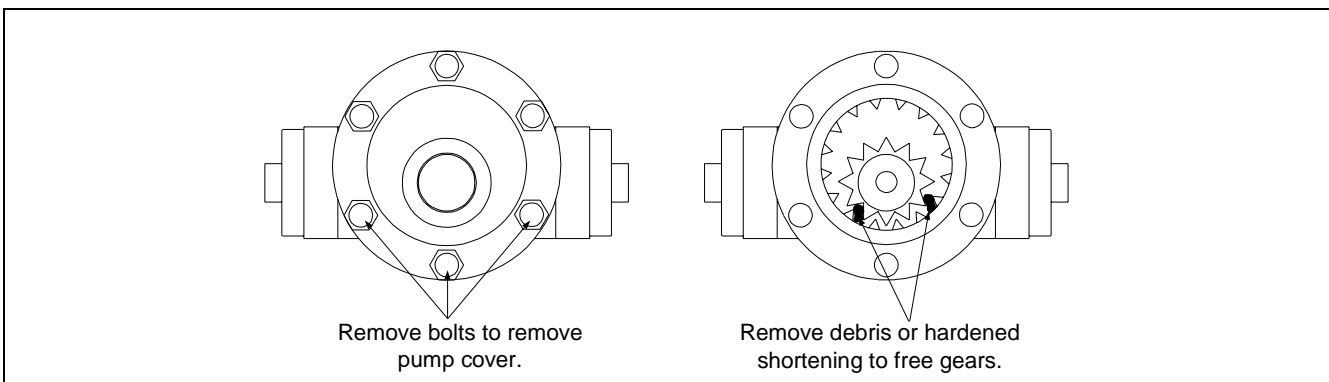

ULTIMATE ELECTRIC SERIES FRYERS

CHAPTER 1: SERVICE PROCEDURES

1.10 Built-in Filter System Service Procedures (cont.)

3. If the front cover is not accessible, the pump must be removed from the pump motor (remove input/output plumbing from the pump prior to removing pump). Remove three setscrews from the pump-shaft housing to disengage the pump from the motor. Remove the gears and thoroughly clean all internal components. Ensure the inside of the pump housing is free of any debris or hardened shortening before reassembling. *Failure to completely clean the inside housing and ring gear will cause gear binding after reassembly.*

Filter paper/pads that are the wrong size or installed incorrectly will also allow food particles and sediment to pass through and clog the suction tube in the bottom of the filter pan. Particles large enough to block the suction tube may indicate that the crumb tray is not being used.

1.11 Basket Lift Service Procedures

Ultimate Electric Series fryers may optionally be equipped with automatic basket lifts to ensure uniform cooking times. Electric fryers can be equipped with "modular" or "bell-crank" basket lifts.

A **modular basket lift** (illustrated) consists of a toothed rod to which the basket lift arm is attached, a reversible-drive gear motor and a pair of roller-activated microswitches. The gear motor engages the teeth in the rod, moving it up or down, depending upon the direction of rotation of the motor. Microswitches at the upper and lower limits of movement stop the motor when the basket is in the full up or full down position.

Timing circuitry in the controller initiates and stops basket lift operation depending upon the variables programmed by the operator. When the product button is pressed, or the manual control is activated, the timing circuitry activates a coil in the basket lift relay to supply power to the lower microswitch. The microswitches stop the motor at the lift's upper and lower travel limits and reverse the direction of current flow thus reversing the motor direction.

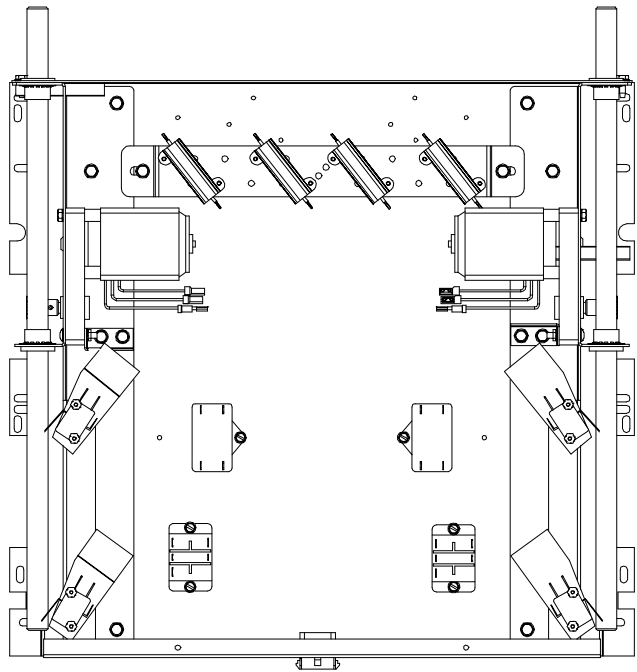

Modular Basket Lift Assembly (Typical).

ULTIMATE ELECTRIC SERIES FRYERS
CHAPTER 1: SERVICE PROCEDURES

1.11 Basket Lift Service Procedures (cont.)

Simplified Schematic

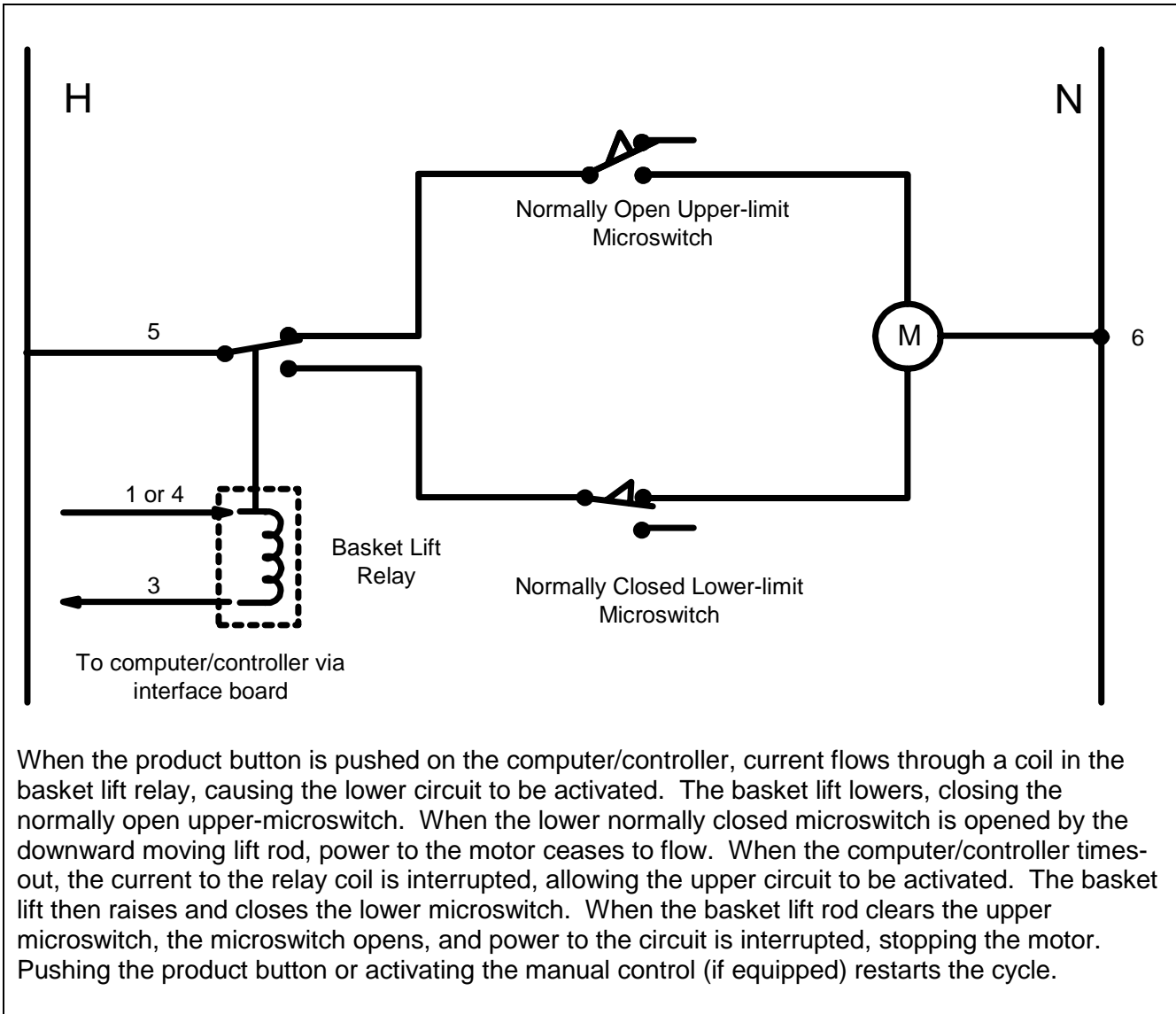

Problems with the modular basket lift design can be grouped into three categories:

- Binding/jamming problems
- Motor and gear problems
- Electronics problems

ULTIMATE ELECTRIC SERIES FRYERS

CHAPTER 1: SERVICE PROCEDURES

1.11 Basket Lift Service Procedures (cont.)

BINDING/JAMMING PROBLEMS

Noisy, jerky or erratic movement of the lifts is usually due to lack of lubrication of the rods and their bushings. Apply a light coat of Lubriplate or similar lightweight white grease to the rod and bushings to correct the problem.

With the modular basket lift, another possible cause of binding is improper positioning of the motor, which prevents the gear from correctly engaging the teeth in the rod. To correct the problem, loosen the screws that hold the motor in place and move it forward or backward until the rod has just enough slack to be rotated slightly.

MOTOR AND GEAR PROBLEMS

With the modular basket lift, the most likely problem to be encountered in this category is erratic motion of the lift due to a worn drive gear. Failure to keep the lift rod and bushings properly lubricated will cause unnecessary wear of the gear. The problem is corrected by replacing the worn gear.

If the lift cycles correctly but fails to remain in the up position (i.e., goes up, but then slowly settles back down into the frypot), the problem is a failed motor brake. The motor must be replaced.

If power is reaching the motor but the motor fails to run, the motor is burned out and must be replaced.

ELECTRONICS PROBLEMS

Within this category are problems associated with the relays, microswitches, capacitors, resistors, interface board, wiring, and controls. The most common problem in this category is a lift that continuously travels up and down. This is usually caused by a microswitch that is out of adjustment.

Troubleshooting the electronics of a modular-type basket lift is simply a process of verifying current flow through the individual components up to and including the motor. Using a multimeter set to the 250 VAC range, check the connections on both sides of the component for the presence of the applied line voltage. The accompanying simplified wiring diagrams identify the components and wiring connection points.

ULTIMATE ELECTRIC SERIES FRYERS

CHAPTER 1: SERVICE PROCEDURES

1.11 Basket Lift Service Procedures (cont.)

Ultimate Electric Series fryers, used to cook large amounts of bone-in chicken in a single drop, are equipped with **bell-crank style basket lifts**. Two components, a cam and bell crank, are connected to the basket lift arm by a flat metal link. The cam is attached to a drive motor. The motor rotates the cam, thus raising or lowering the lift arm linked to the bell crank. A roller-activated microswitch is used to limit travel. When the roller in the microswitch is in contact with the cam, the motor is energized. As the cam rotates, the roller loses contact with the cam and the motor power circuit is broken, de-energizing the motor.

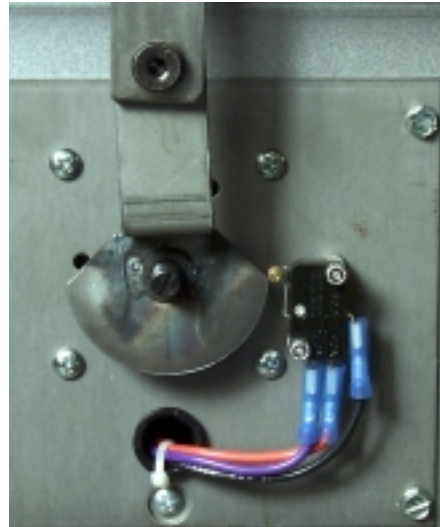

Bell-crank style basket lift.

Timing circuitry in the controller initiates and stops basket lift operation. When the product button is pressed, the timing circuitry activates a coil in the basket lift relay to supply power to the motor. The microswitch stops the motor at the lift's lower travel limit and the switch contacts are reversed. At the end of the programmed cooking time, the timing circuit activates the coil once more and the lift rises until the microswitch again loses contact with the cam, opening the motor power circuit and stopping the motor. A typical bell-crank wiring diagram is shown below.

REFERENCES TO LEFT & RIGHT ARE FROM REAR OF FRYER

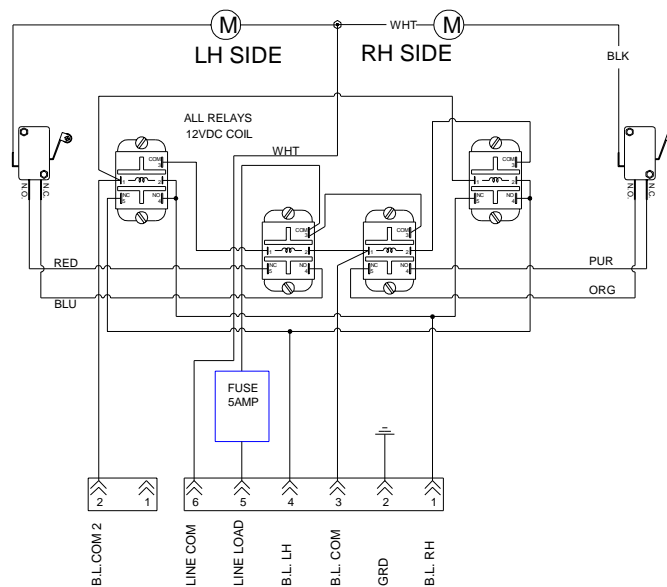

ULTIMATE ELECTRIC SERIES FRYERS

CHAPTER 1: SERVICE PROCEDURES

1.12 Electric Interface Board Diagnostic Chart

The following diagram and charts provide ten quick system checks that can be performed using only a multimeter.

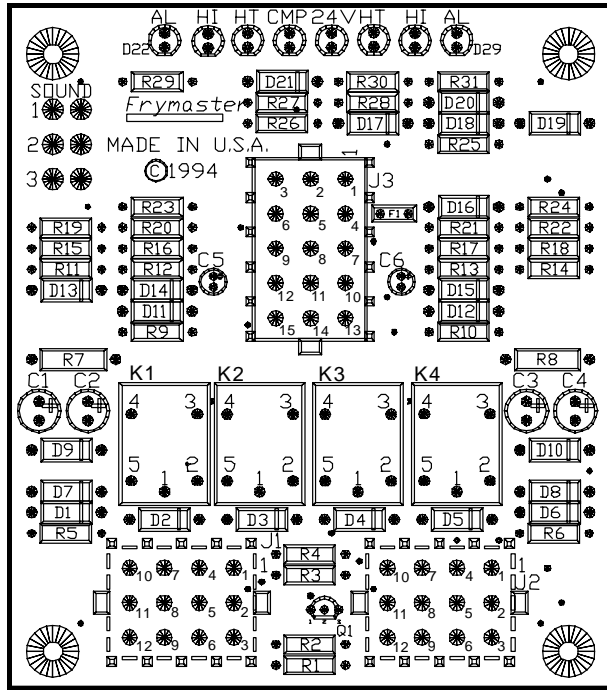

Note: The sealed relays are not replaceable. If a relay fails, the interface board must be replaced.

Diagnostic LED Legend

- CMP indicates power from 12V transformer
- 24 indicates power from 24V transformer
- HI (RH) indicates output (closed) from right latch relay
- HI (LH) not applicable to Ultimate Electric fryers
- HT (RH) indicates output from right heat relay
- HT (LH) not applicable to Ultimate Electric fryers
- AL (RH) indicates output (open) from right latch relay
- AL (LH) not applicable to Ultimate Electric fryers

Meter Setting	Test	Pin	Pin	Results
12 VAC Power	50 VAC Scale	1 of J2	3 of J2	12-16 VAC
24 VAC Power	50 VAC Scale	2 of J2	Chassis	24-30 VAC
*Probe Resistance	R X 1000 OHMS	11 of J2	12 of J2	See Chart
Hi-Limit Continuity	R X 1 OHMS	7 of J2	4 of J2	0 - OHMS
Latch Contactor Coil	R X 1 OHMS	8 of J2	Chassis	3-10 OHMS
Heat Contactor Coil	R X 1 OHMS	9 of J2	Chassis	18-25 OHMS

***Disconnect 15-Pin harness from the computer/controller before testing the probe circuit.**

ULTIMATE ELECTRIC SERIES FRYERS

CHAPTER 1: SERVICE PROCEDURES

1.13 Probe Resistance Chart

Use the chart below when testing temperature probes and probe circuits for proper operation.

Probe Resistance Chart														
F	OHMS	C	F	OHMS	C	F	OHMS	C	F	OHMS	C	F	OHMS	C
60	1059	16	130	1204	54	200	1350	93	270	1493	132	340	1634	171
65	1070	18	135	1216	57	205	1361	96	275	1503	135	345	1644	174
70	1080	21	140	1226	60	210	1371	99	280	1514	138	350	1654	177
75	1091	24	145	1237	63	215	1381	102	285	1524	141	355	1664	179
80	1101	27	150	1247	66	220	1391	104	290	1534	143	360	1674	182
85	1112	29	155	1258	68	225	1402	107	295	1544	146	365	1684	185
90	1122	32	160	1268	71	230	1412	110	300	1554	149	370	1694	188
95	1133	35	165	1278	74	235	1422	113	305	1564	152	375	1704	191
100	1143	38	170	1289	77	240	1432	116	310	1574	154	380	1714	193
105	1154	41	175	1299	79	245	1442	118	315	1584	157	385	1724	196
110	1164	43	180	1309	82	250	1453	121	320	1594	160	390	1734	199
115	1174	46	185	1320	85	255	1463	124	325	1604	163	395	1744	202
120	1185	49	190	1330	88	260	1473	127	330	1614	166	400	1754	204
125	1195	52	195	1340	91	265	1483	129	335	1624	168	405	1764	207

1.14 Element Wattage/Amperage Calculation Charts

Use the charts below when changing voltages or determining amperage for a given element configuration.

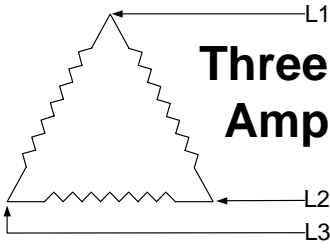

Three Phase Amperage

To determine Three Phase Amperage, solve for Single Phase first:

$$\frac{\text{Wattage}}{\text{Voltage}} = \text{Single Phase Amps}$$

Then divide the Single Phase Amperage by 1.73 to determine Three Phase Amperage.

Example:

$$\frac{17,000\text{W}}{240\text{V}} = \frac{70.833 \text{ Amps}}{1.73}$$

= 40.944 Amps per Phase

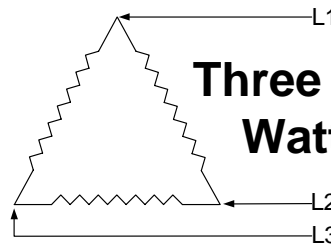

Three Phase Wattage

To compute the New Wattage Rating of an element if a different voltage is applied, use the following formula:

$$\left[\frac{\text{New Voltage}}{\text{Old Voltage}} \right]^2 \times \text{kW Listed}$$

= New Wattage Rating

Example:

If 208V supply is applied to a 17 kW element rated for 240V, the calculation is as follows:

$$\left[\frac{208\text{V}}{240\text{V}} \right]^2 \times 17,000 \text{ Watts}$$

= 12.77 kW

ULTIMATE ELECTRIC SERIES FRYERS
CHAPTER 1: SERVICE PROCEDURES

1.15 Wiring Diagrams, Main

1.15.1 Wiring Diagram, Main- 480V: 18UE and EH1721

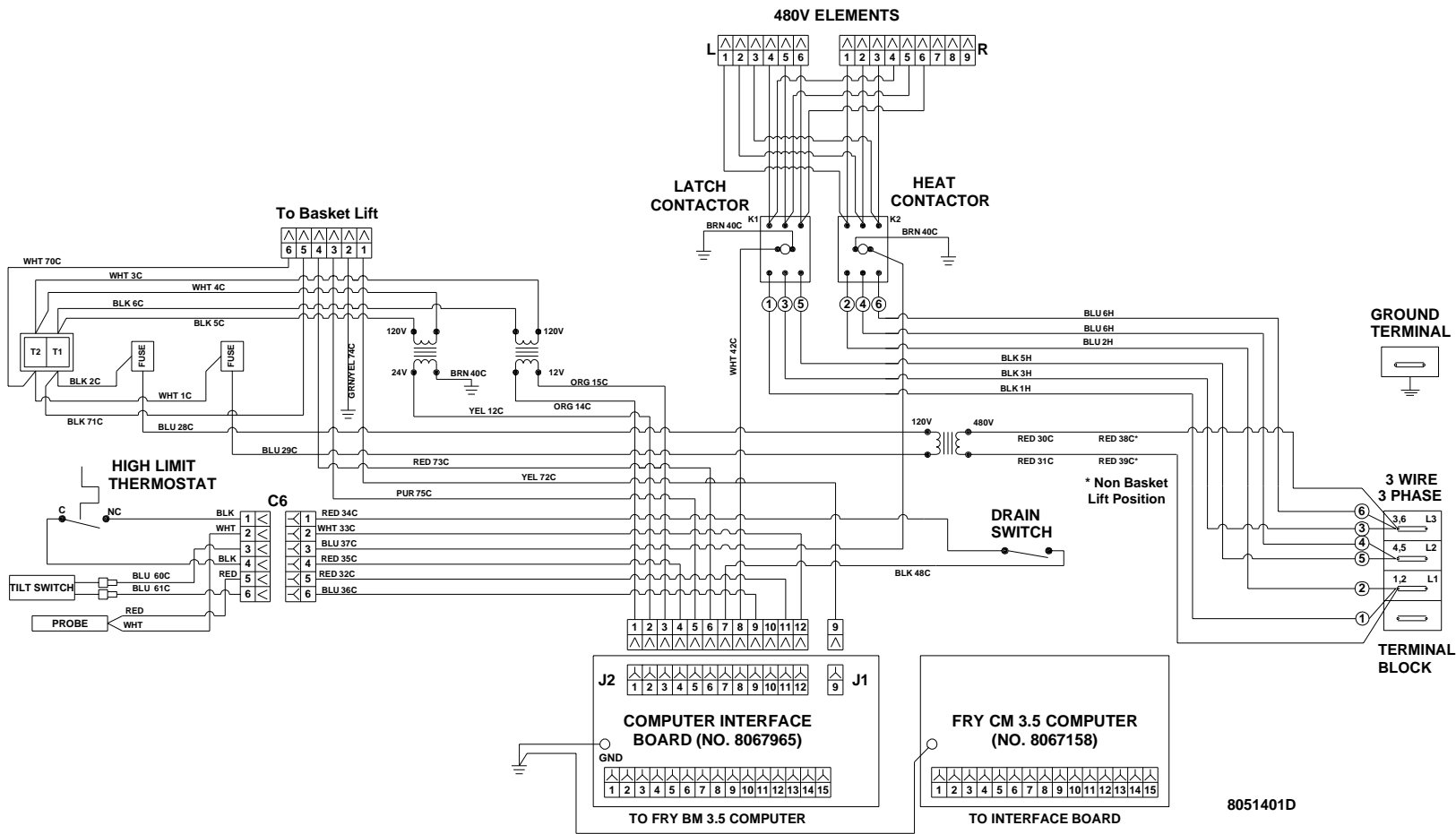

8051401D

ULTIMATE ELECTRIC SERIES FRYERS
CHAPTER 1: SERVICE PROCEDURES

1.15.2 Wiring Diagram, Main- 208V- 18UE and EH1721

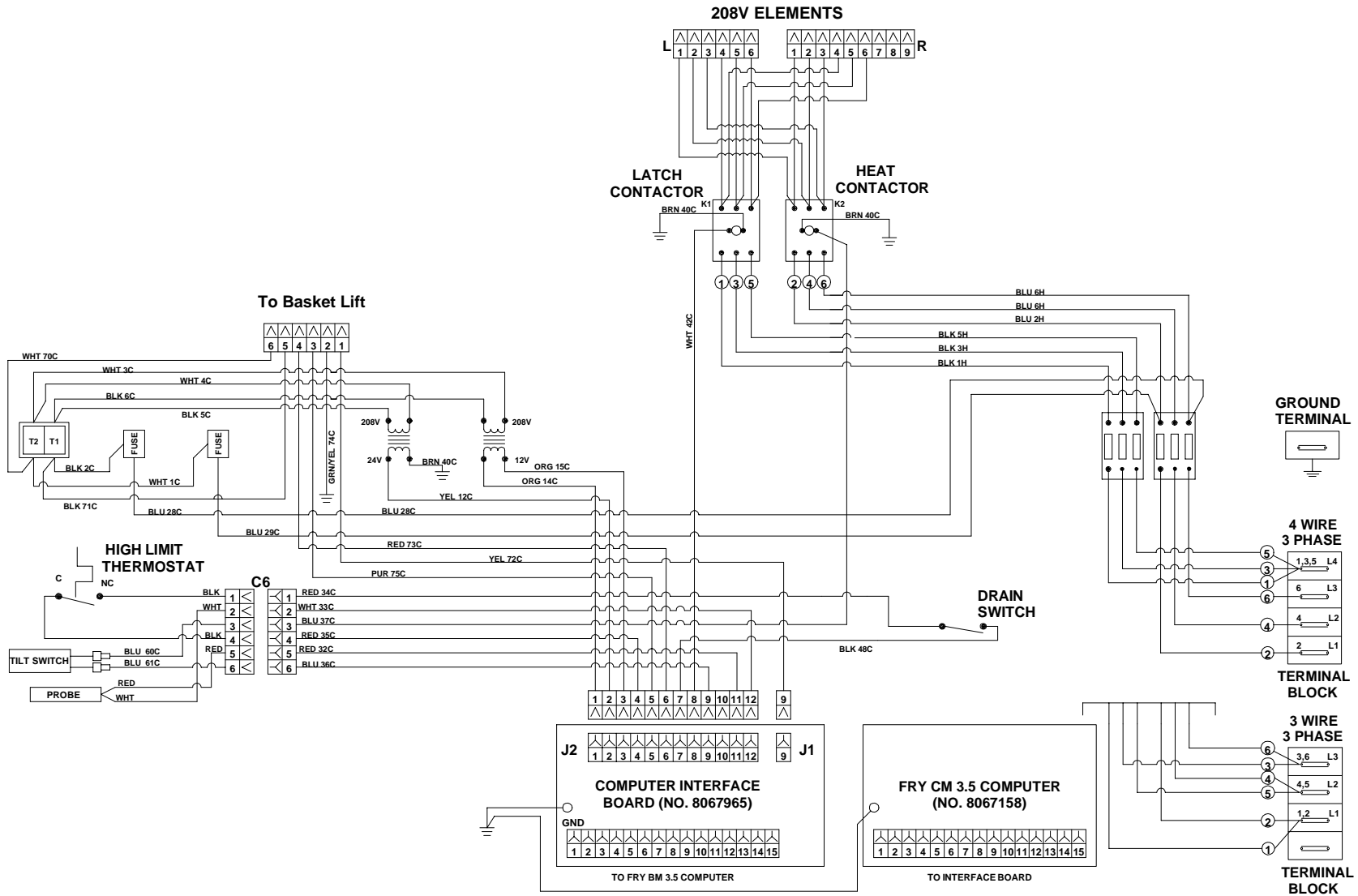

8051412A

ULTIMATE ELECTRIC SERIES FRYERS

CHAPTER 1: SERVICE PROCEDURES

1.15.3 Wiring Diagram, Main- KSCFH218E

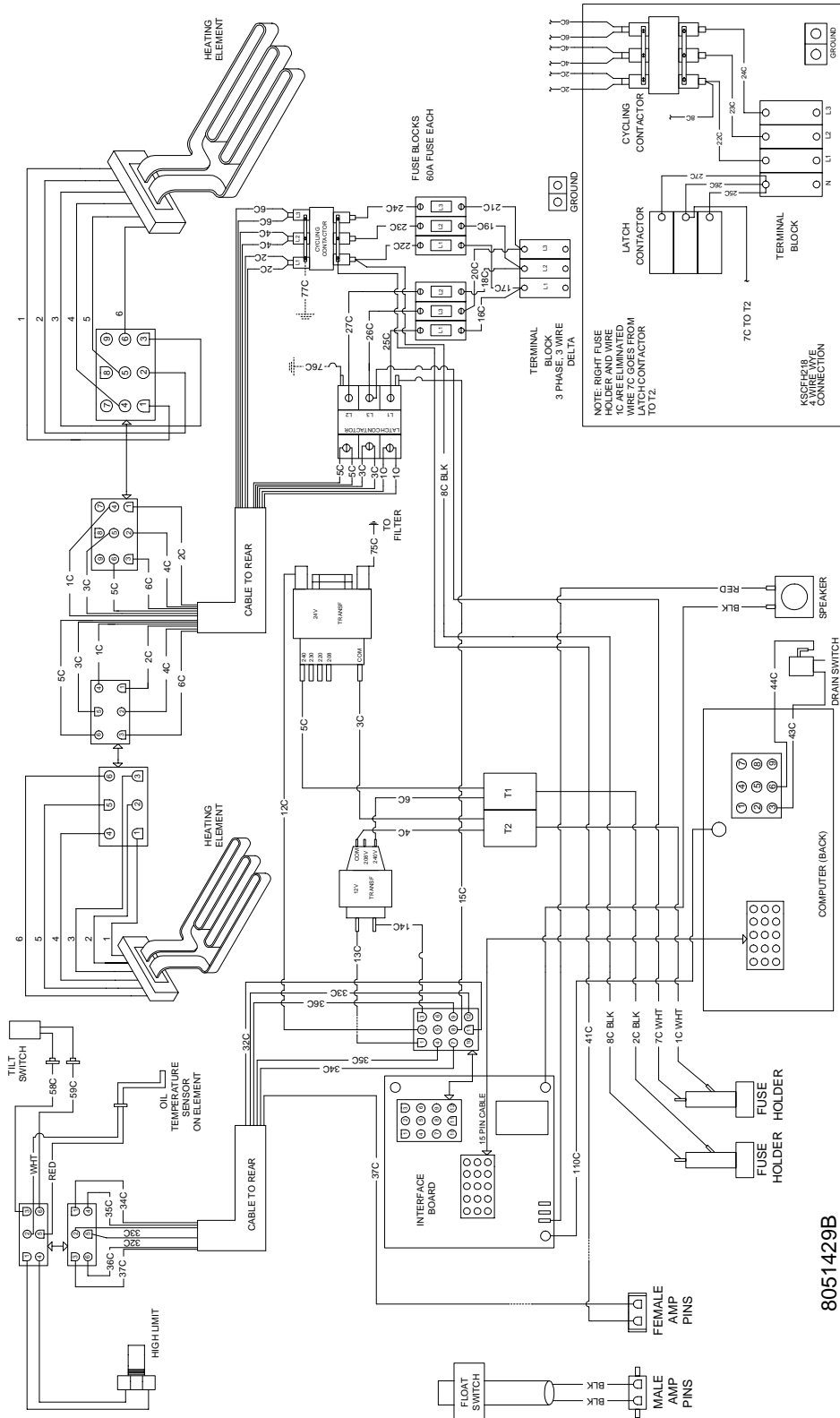

8051429B

ULTIMATE ELECTRIC SERIES FRYERS

CHAPTER 1: SERVICE PROCEDURES

1.15.4 Wiring Diagram, Main- BIH1721

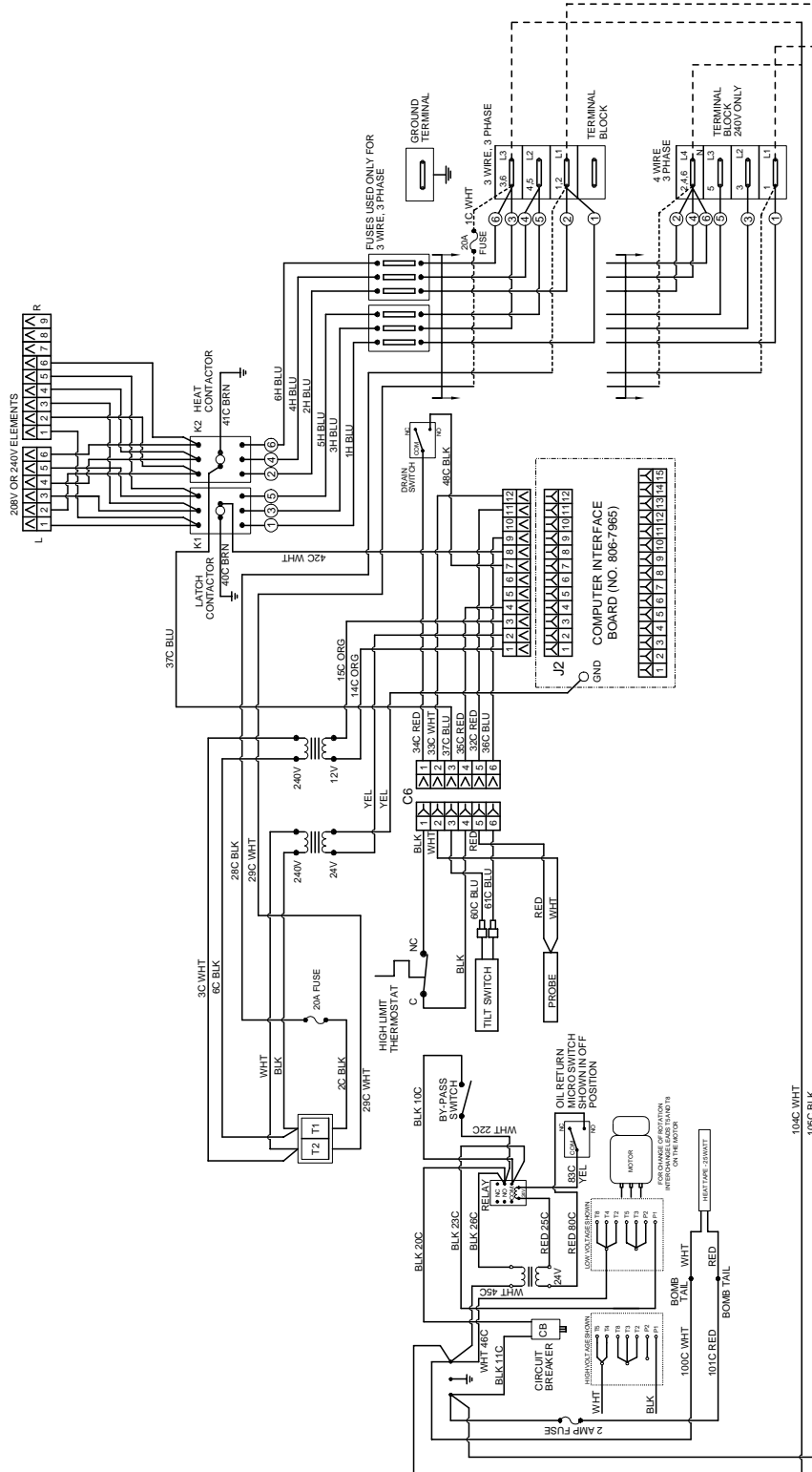

8051445B

ULTIMATE ELECTRIC SERIES FRYERS

CHAPTER 1: SERVICE PROCEDURES

1.16 Wiring Diagrams, Basket Lifts

1.16.1 Modular Basket Lifts

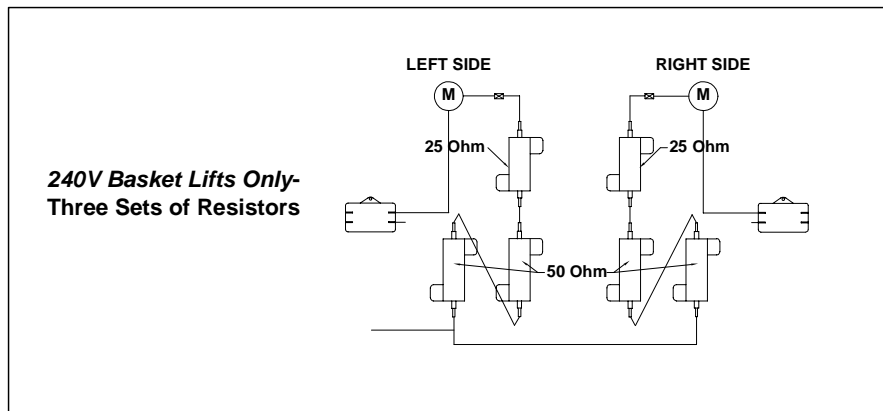
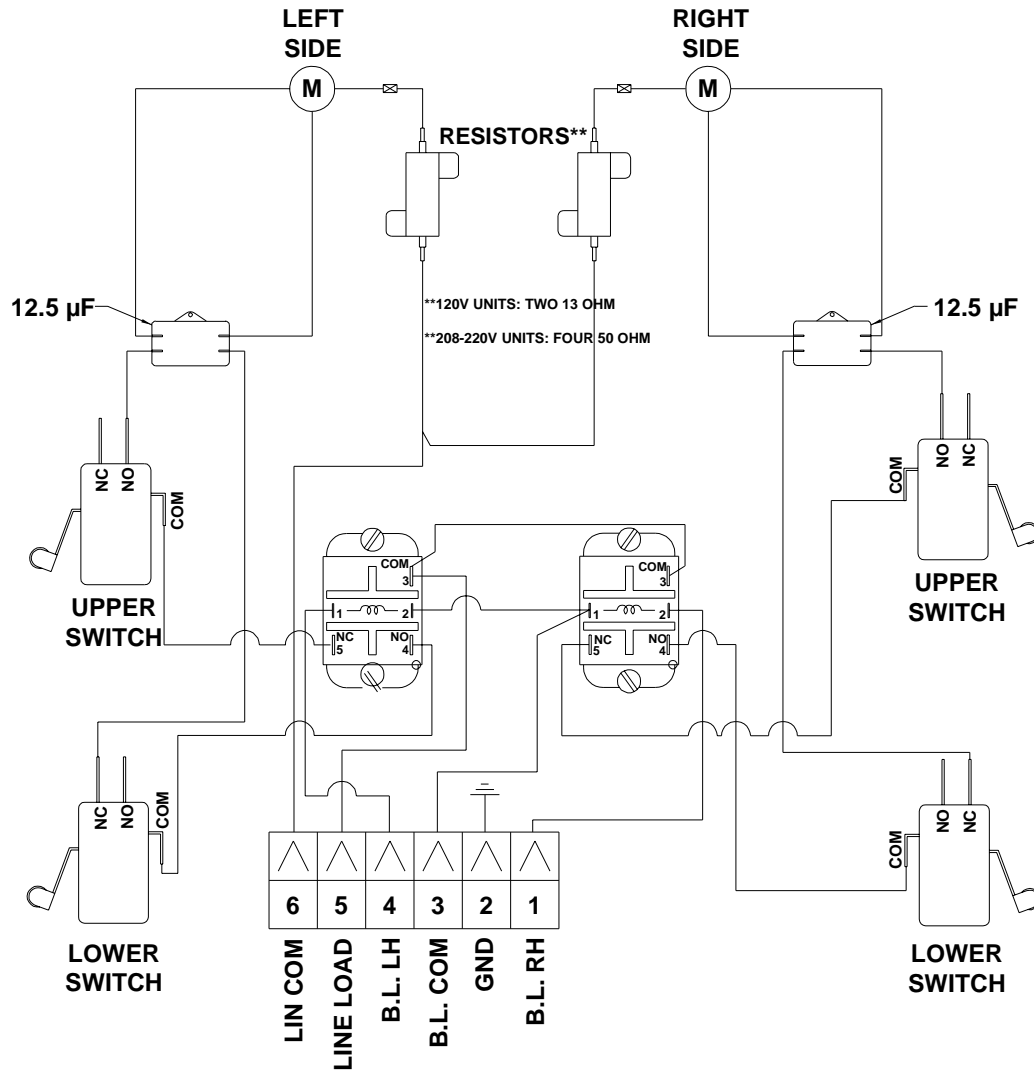

ULTIMATE ELECTRIC SERIES FRYERS

CHAPTER 1: SERVICE PROCEDURES

1.16.2 Bell-Crank Style Basket Lifts

REFERENCES TO LEFT & RIGHT ARE FROM REAR OF FRYER

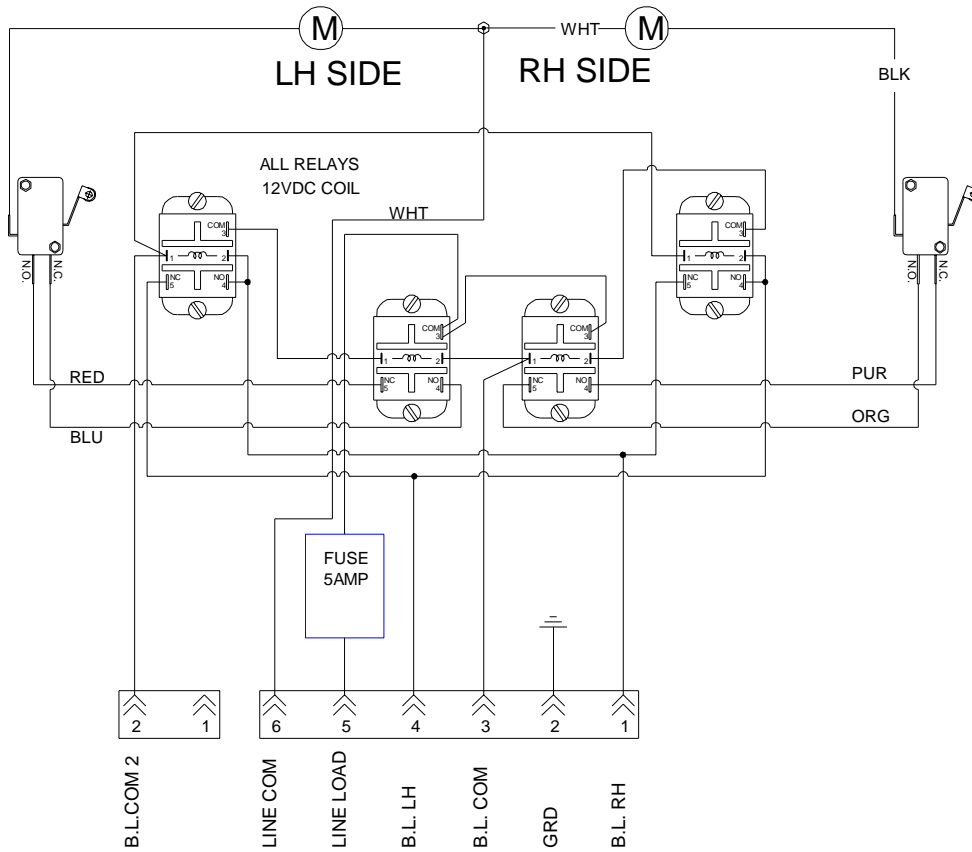

ULTIMATE ELECTRIC SERIES FRYERS
CHAPTER 1: SERVICE PROCEDURES

1.17 Wiring Diagrams: Built-in Filtration

1.17.1 Wiring Diagram, 480V Systems With Built-in Filtration

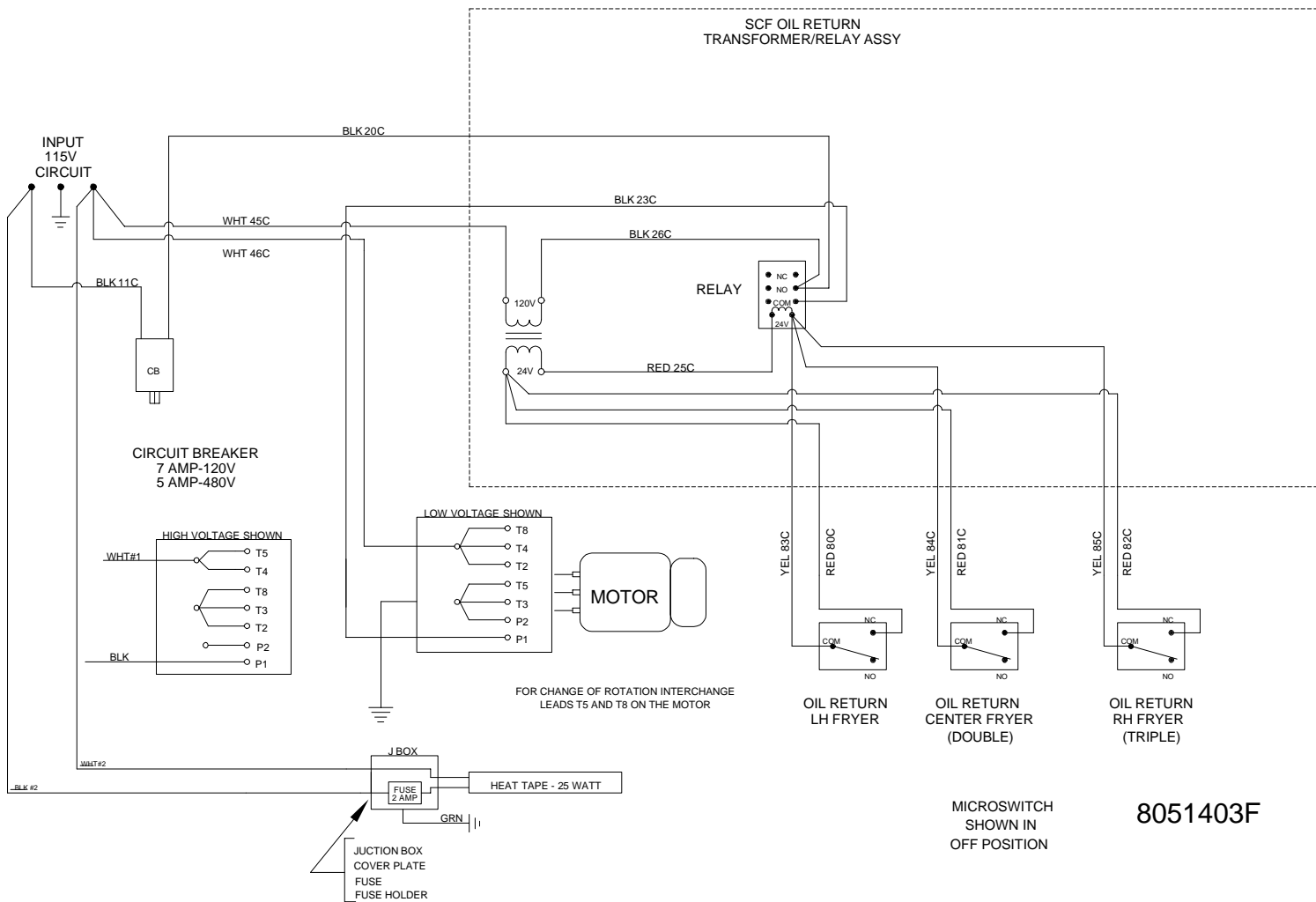

ULTIMATE ELECTRIC SERIES FRYERS
CHAPTER 1: SERVICE PROCEDURES

1.17.2 Wiring Diagram, 208V Systems With Built-in Filtration

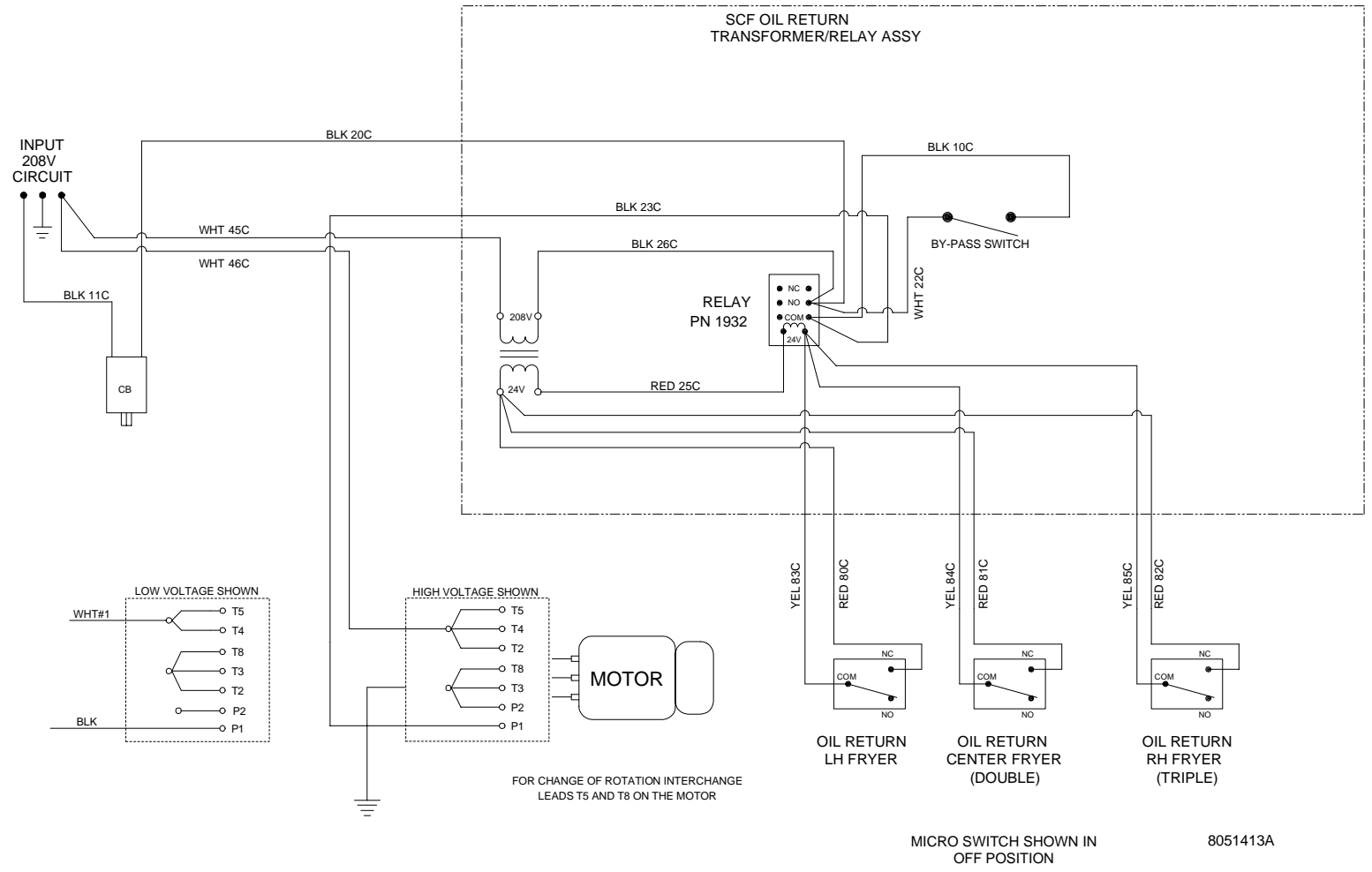

ULTIMATE ELECTRIC SERIES FRYERS
CHAPTER 1: SERVICE PROCEDURES

1.17.3 Wiring Diagram, 115/230V KFC Systems With Built-in Filtration

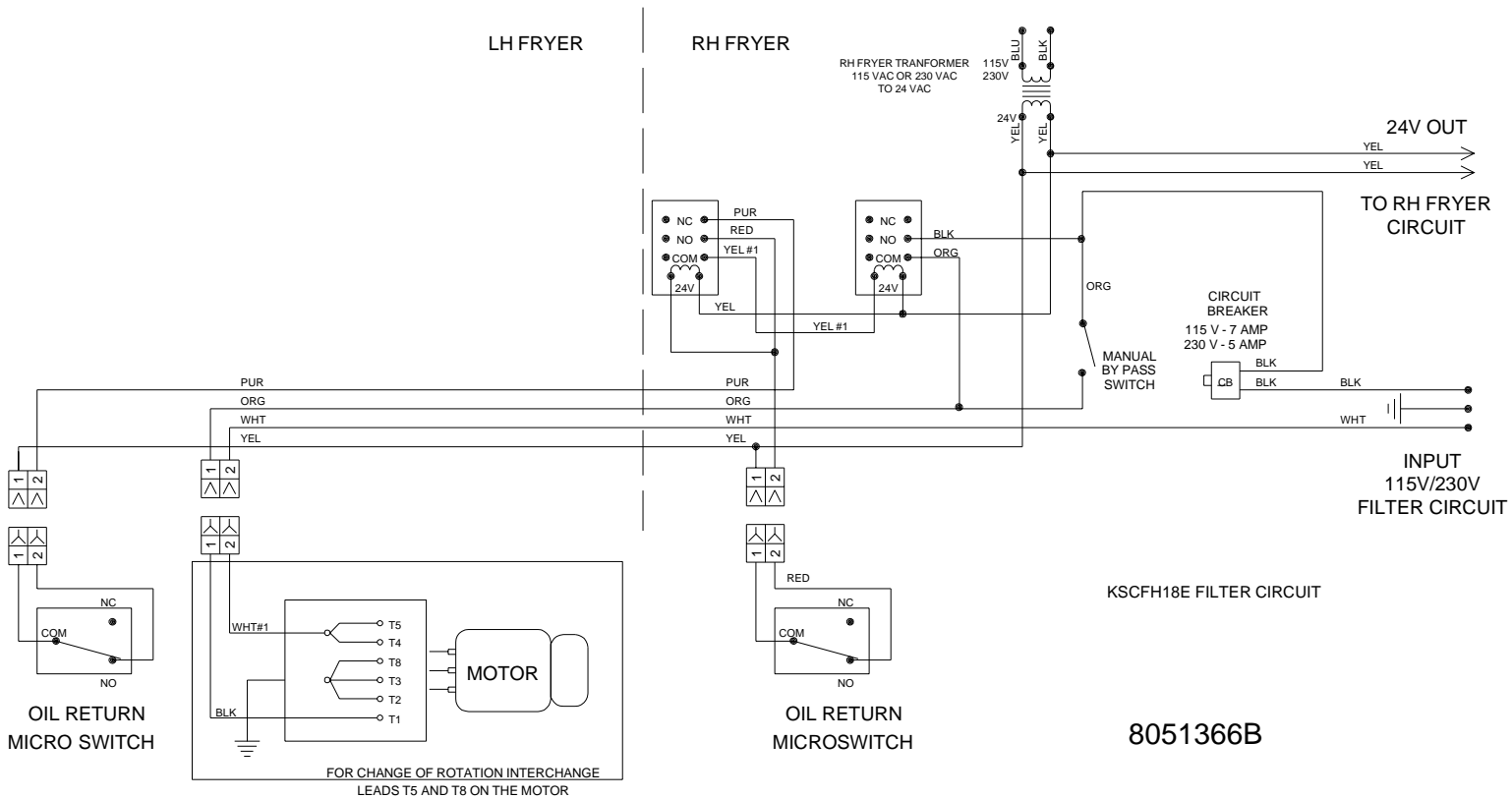

8051366B

ULTIMATE ELECTRIC SERIES FRYERS

CHAPTER 2: PARTS LIST

2.1 Accessories

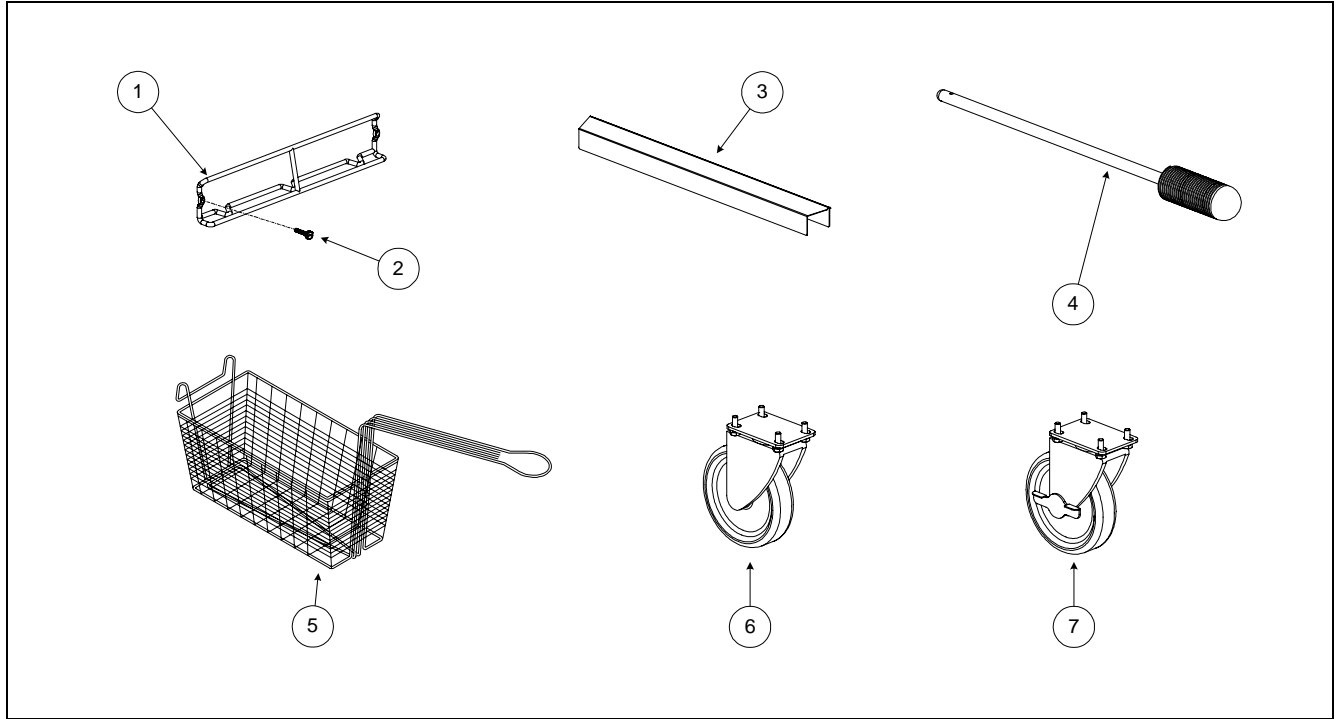

Item	Part Number	Description
1	810-2092	Basket Hanger
*	106-1968	Cover, Vat- <u>All Ultimate Electrics</u>
2	809-0171	Thumbscrew, Basket Hanger
3	210-1288	Joiner Strip
4	803-0209	Brush, Frypot
*	810-2120	Grid, Frypot W/Standoff
*	803-0149	Grid, Frypot- FPH1721 Systems
5	803-0306	Fry Basket, Twin Basket
*	803-0017	Fry Basket, Full Basket
6	826-1117	Caster, 5"- W/O Brake (Mounting Hardware Included)
7	826-1118	Caster, 5"- With Brake (Mounting Hardware Included)
*	803-0197	Fryer's Friend (Clean-out Rod)

* Not Illustrated

**ULTIMATE ELECTRIC SERIES FRYERS
CHAPTER 2: PARTS LIST**

2.2 Basket Lift Assembly (Modular) and Related Components

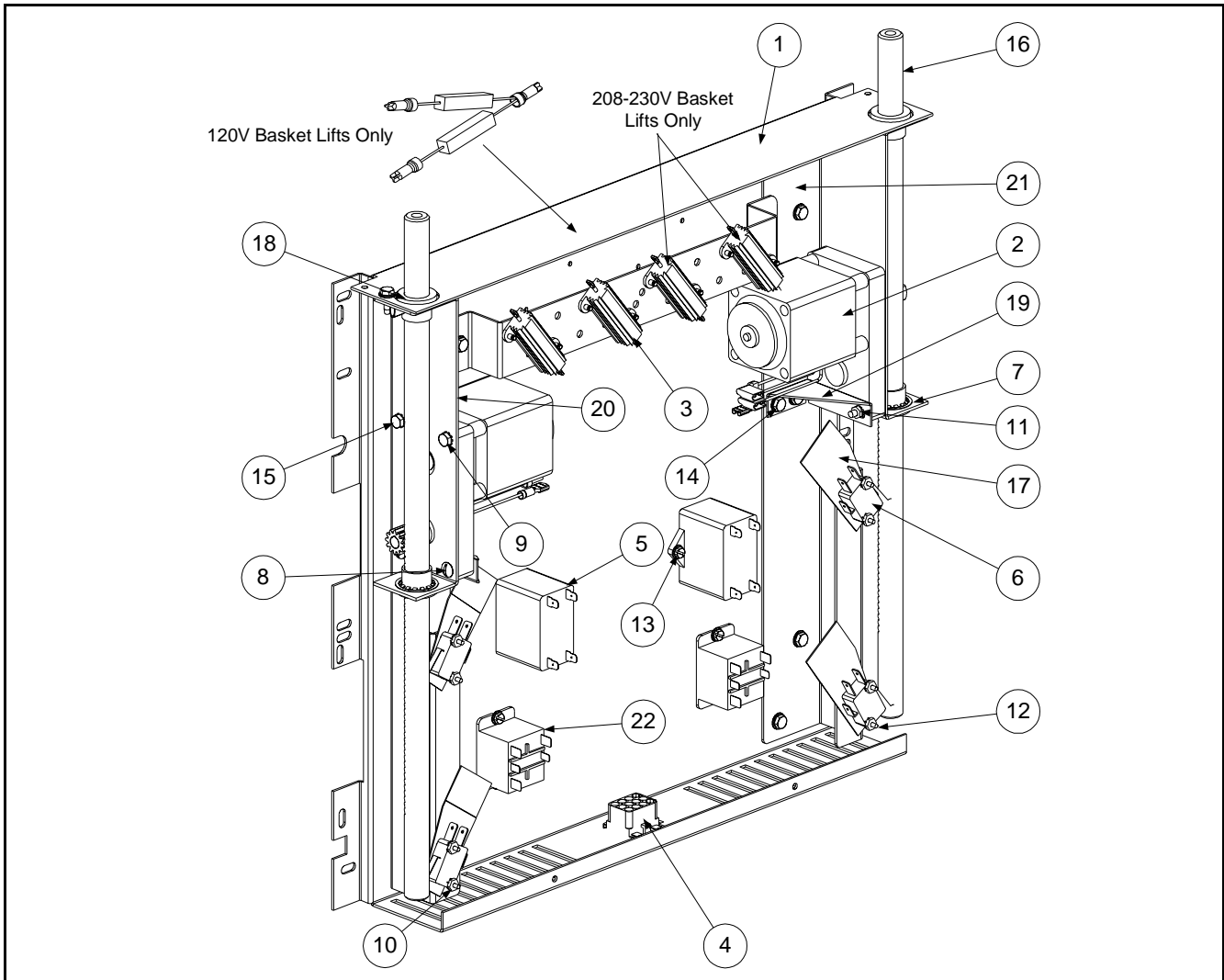

Item	Part Number	Description
1	200-2564	Mount, Basket Lift Assembly
2	806-5964	Motor Assembly- All EH1721 Basket Lifts
3	106-2770SP	Resistor Assembly, 200/208/220V
*	106-2771SP	Resistor Assembly, 230/240/250V
	806-8530SP	Resistor Assembly, 120V (Used On 480V Fryers)
*	807-2661	Resistor, 13 Ohm-120V (For 480V Fryers)
*	807-3893	Resistor, 50 Ohm- 200V/250V (For 208/220V and 230/250 Fryers)
*	807-2511	Resistor, 25 Ohm- 230V/250V (For 230/250V Fryers)
* Not Illustrated		

**ULTIMATE ELECTRIC SERIES FRYERS
CHAPTER 2: PARTS LIST**

2.2 Basket Lift Assembly (Modular) and Related Components (cont.)

Item	Part Number	Description
4	807-0159	Connector, 12-Pin
5	807-2133	Capacitor, 120V Basket Lifts
*	807-2513	Capacitor, 208V Basket Lifts
6	807-2572	Microswitch
7	809-0082	Ring, Truarc
8	809-0111	Screw, 8-32
9	809-0186	Washer, Lock #6
10	809-0237	Nut, 4-40
11	809-0247	Nut, 8-32, Hex Keys
12	809-0354	Screw, 4-40 x 3/4"
*	809-0358	Screw, 4-40 x 1/4" (Use with 208V Basket Lifts)
13	809-0361	Screw, (Drill #8)
14	809-0412	Screw #10-1/2 Hex
15	809-0503	Screw, Hex 8-32 x 1/2"
16	810-1012	Basket Lift Rod
17	812-0442	Insulation, Switch Box
18	813-0035	Bushing, Bronze .620 ID
19	900-5529	Gusset
20	901-8499	Chassis, Left
21	902-8499	Chassis, Right
22	807-1683	Relay, 12VDC
*	200-2565	Enclosure, Basket Lift Assembly
*	200-3232	Mount, Conduit- Basket Lift Wire Harness Cover
*	200-3224	Cover, Basket Lift Wire Harness
* Not Illustrated		

ULTIMATE ELECTRIC SERIES FRYERS
CHAPTER 2: PARTS LIST

2.2 Basket Lift Assembly (Modular) and Related Components (cont.)

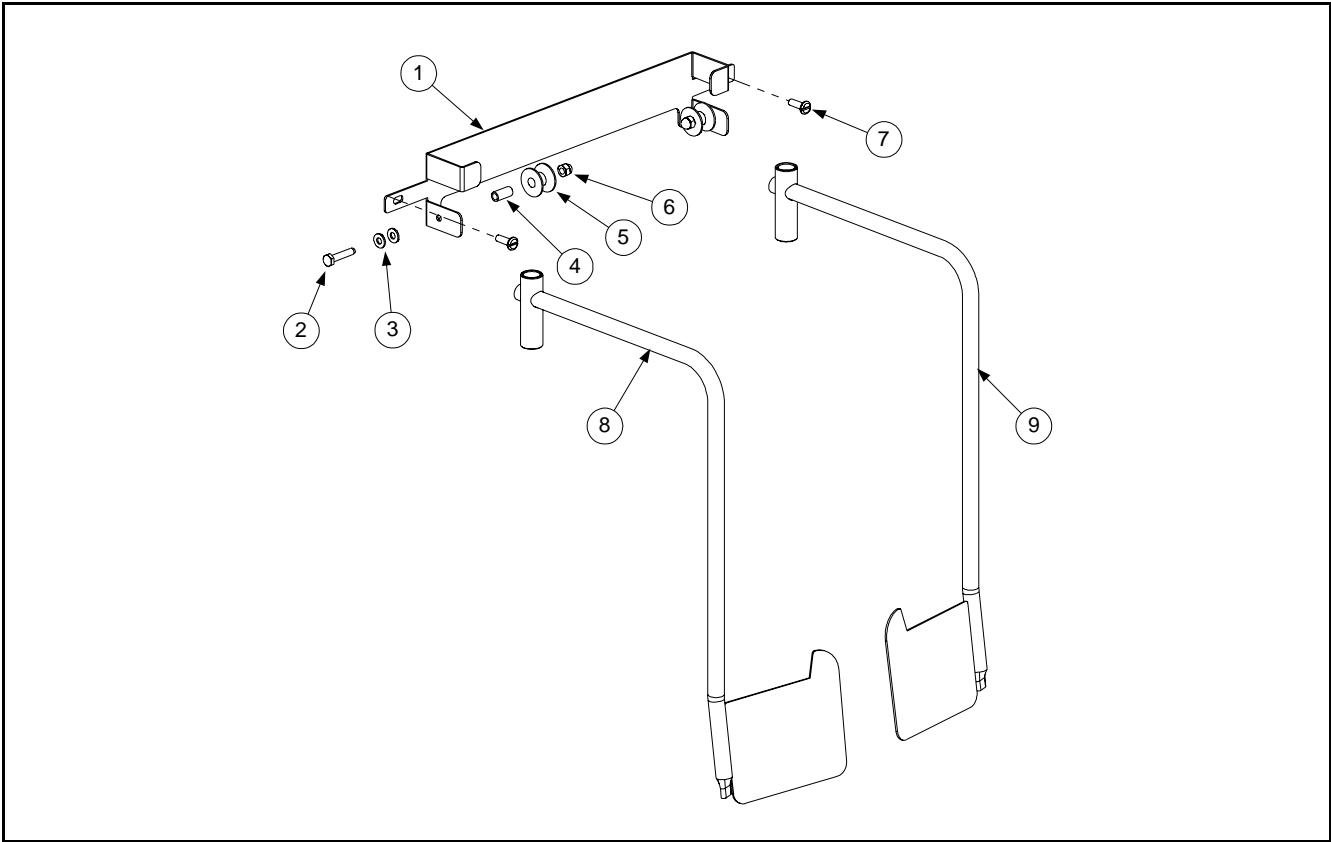

Item	Part Number	Description
1	106-1594SP	Roller Assembly, Bracket
2	809-0508	Bolt, 1/4-20 x 1-1/4" Hex Head S/S
3	809-0190	Washer, Flat- 1/4" S/S
4	810-0374	Spacer, Tubular Basket Lift Roller
5	810-0194	Roller, Basket Lift
6	809-0047	Nut, Cap- 1/4-20 S/S
7	809-0132	Screw, 1/4-20 x 3/4" Round Slotted S/S
8	823-3992	Basket Lift Arm- Left
9	823-3993	Basket Lift Arm- Right

ULTIMATE ELECTRIC SERIES FRYERS
CHAPTER 2: PARTS LIST

2.3 Cabinetry and Related Components

2.3.1 EH1721 & 18UE

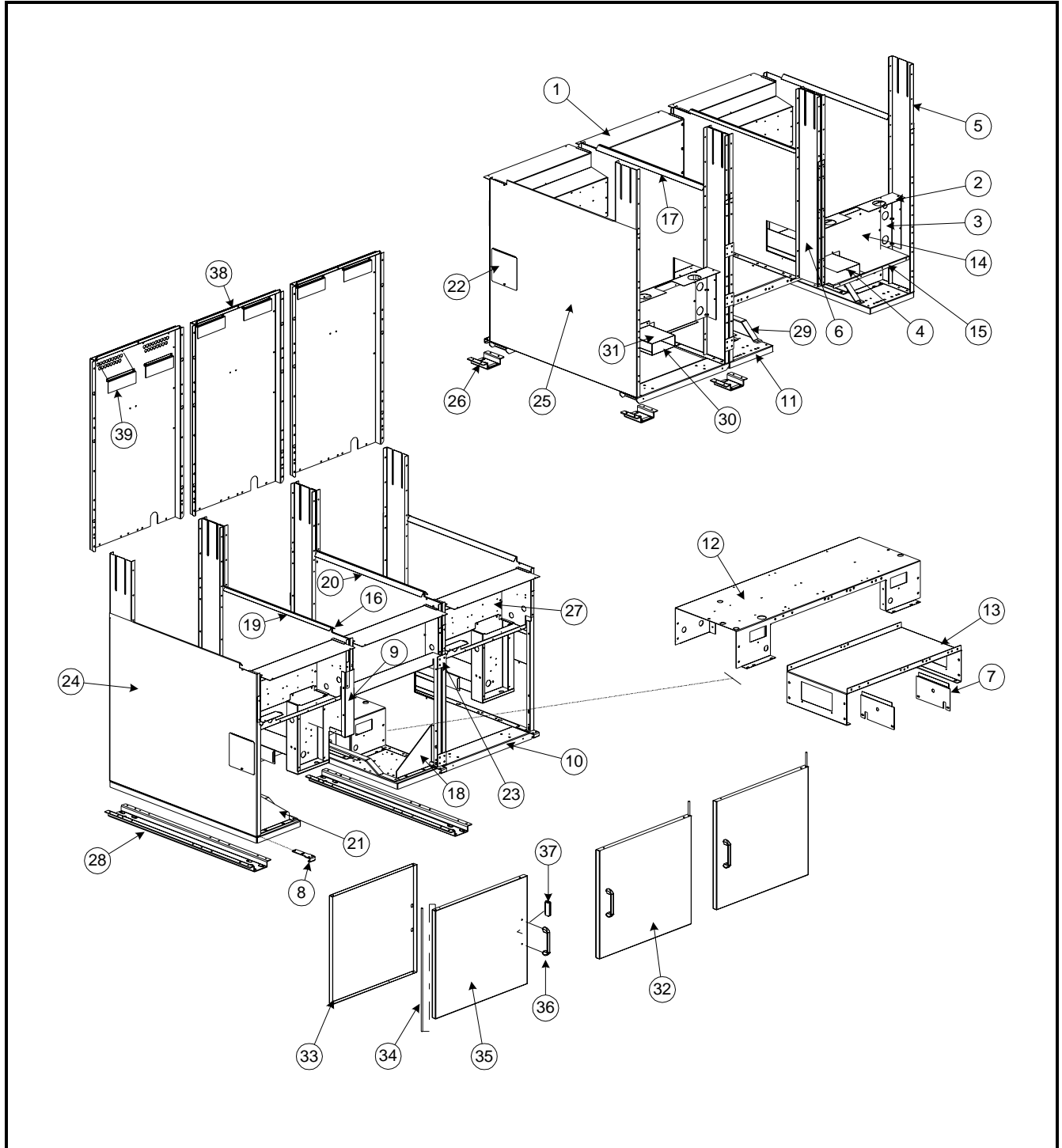

**ULTIMATE ELECTRIC SERIES FRYERS
CHAPTER 2: PARTS LIST**

2.3.1 EH1721 & 18UE (cont.)

Item	Part Number	Description
1	106-1724SP	Cover Assembly, Dump Station Front
2	200-1254	Guard, Rear Wire- Top
3	200-1255	Guard, Rear Right Center Wire, Side
4	200-1263	Channel, Bus Electric
5	200-1284	Channel, Vessel- Outer Back Panel
6	200-1285	Channel, Vessel- Outer Back Panel
7	200-1331	Shield, Burner- Heat
8	200-1675	Bracket, Lower Hinge
9	200-2308	Post, Door
10	200-2493	Channel, Front & Rear- Single and 2-Battery With Dump Station
*	200-2534	Channel, Front & Rear- 3-Battery With Dump Station
11	200-2526	Channel, Base
12	200-3215	Frame, Base- 1721 Systems
*	200-3491	Frame, Base- BIH1721
13	200-3264	Base, Cabinet Lower Frame- 1721 Systems
*	200-3494	Base, Cabinet Lower Frame- BIH1721
14	200-3242	Guard, Center Rear Wire
15	200-2842	Cover, Structural Back- Lower
16	201-3216	Panel, Inner-Left Side
17	201-2533	Side, Cabinet- Left (With Hole)
18	201-2552	Gusset, Side Panel- Left
19	202-3216	Panel, Inner- Right Side
20	202-2533	Side, Cabinet- Right (With Hole)
21	202-2552	Gusset, Side Panel- Right
22	210-2756	Duct, Door Access
23	210-2848	Bracket, Cabinet Batter
24	211-2532	Side, Cabinet- Left Side
25	212-2532	Side, Cabinet- Right Side
26	823-3248	Support, Leg
27	823-3458	Wireway, Control Panel
* Not Illustrated		

**ULTIMATE ELECTRIC SERIES FRYERS
CHAPTER 2: PARTS LIST**

2.3.1 EH1721 & 18UE (cont.)

Item	Part Number	Description
28	823-3468	Channel, Leg Support
29	823-3559	Slide, Filter Pan Support
30	200-3240	Bottom, Bus Channel
31	823-3688	Cover, Bus Channel (With Bracket)
32	106-0855SP	Door Assembly (Door Pin Not Included) See Section 2.3.3 For Additional Door Components
33	200-1185	Panel, Door- Inner
34	200-1301	Door Pin
35	210-1271	Panel, Door- Outer
36	810-0180	Handle, Door
*	809-0918	Screw, 10-24 x ½" Slotted Head (Use With 810-2105)
*	809-0191	Washer, ¼ Spring-Lock (Use With 810-2105)
37	810-0066	Magnet, Door
38	200-1252	Back, Upper Cabinet
39	200-1283	Cover, Vent- Cabinet Back
* Not Illustrated		

ULTIMATE ELECTRIC SERIES FRYERS
CHAPTER 2: PARTS LIST

2.3.2 KFC18E Electric

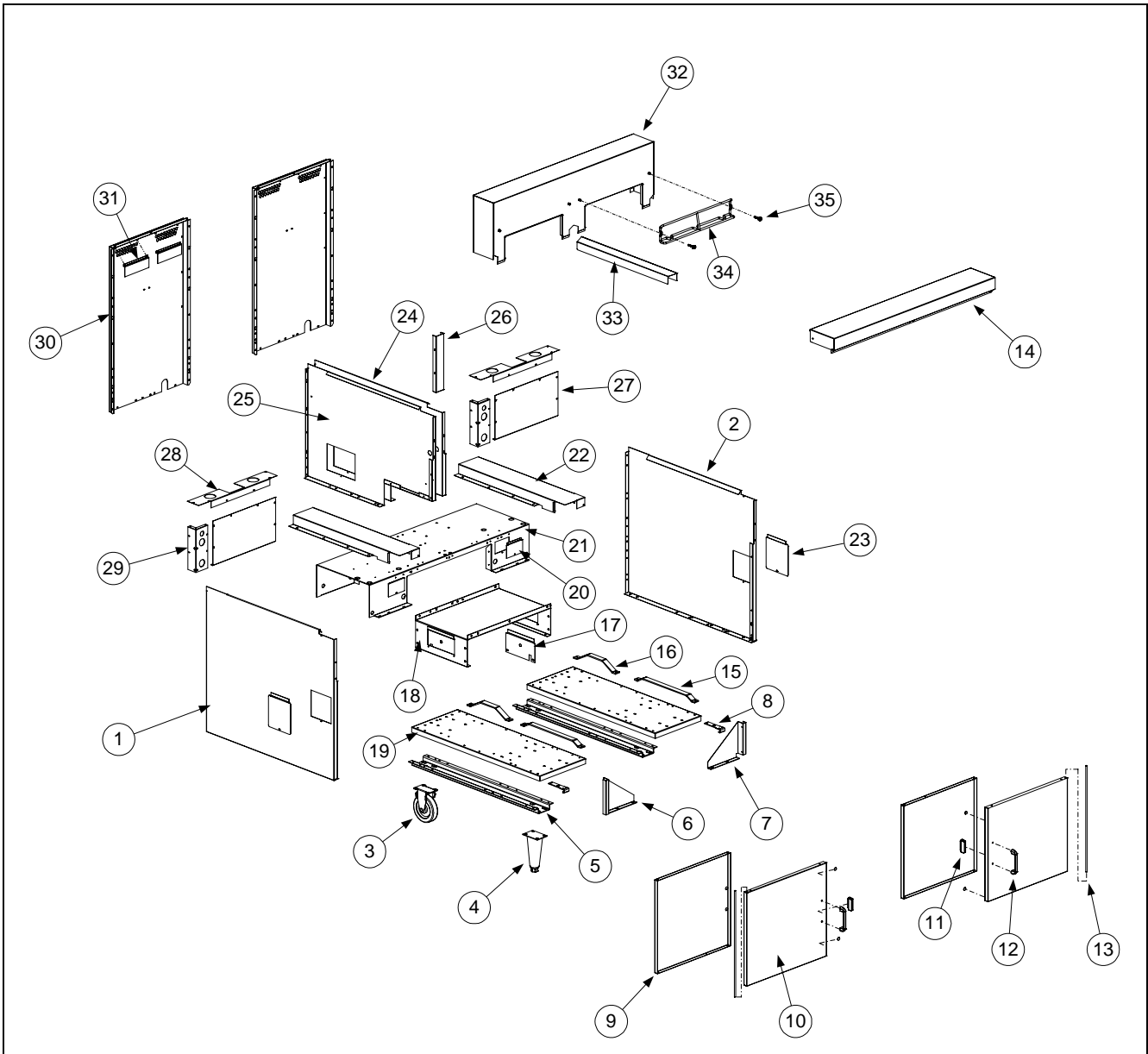

ULTIMATE ELECTRIC SERIES FRYERS
CHAPTER 2: PARTS LIST

2.3.2 KFC18E Electric (cont.)

Item	Part #	Description
1	201-1299	Side Panel, Painted, LH
2	202-1299	Side Panel, Painted, RH
3	810-0378	Caster, Stationary- 5" Rigid
4	806-5043	Leg
0	823-3180	Support, Channel- Leg/Caster
6	201-1182	Gussets, L/H
7	202-1182	Gussets, R/H
8	200-1675	Lower Hinge Bracket (Door)
9	200-1185	Door Panel, Inner
10	210-1271SP	Door Panel, Outer
*	106-0855SP	Door Assembly (Door Pin Not Included) See Section 2.3.3 For Additional Door Components
11	810-1105	Magnetic Door Catch
12	810-0180	Handle, Door
*	809-0918	Screw, 10-24 x ½" Slotted Head (Use With 810-2105)
*	809-0191	Washer, ¼ Spring-Lock (Use With 810-2105)
13	200-1301	Door Pin
14	210-1262	Top Cap
15	210-1806	Slide, UFF Filter Pan- Front (Long)
16	210-2128	Slide, UFF Filter Pan- Rear (Short)
17	200-1331	Shield, Heat
18	200-1297	Base, Lower Frame
19	200-1198	Channel, Base
20	200-2134	Plate, Mounting (UFF)
21	200-1611	Base, Upper
22	200-1263	Channel, Bus
23	200-1471	Cover, Access Duct
24	202-1245	Panel, Inner- Right Side
25	201-1245	Panel, Inner- Left Side
26	200-2308	Post, Door
27	210-1278	Guard, Wire- Center
28	200-1254	Guard, Wire- Top
29	200-1255	Guard, Wire- Right Side Center
30	200-1252	Back, Cabinet
*	200-3362	Closure, Lower Structural Back (Single Fryers)
* Not Illustrated		

ULTIMATE ELECTRIC SERIES FRYERS
CHAPTER 2: PARTS LIST

2.3.2 KFC18E Electric (cont.)

Item	Part #	Description
31	200-1283	Cover, Back Vent
*	809-0360	Screw, Hex Slotted Head – With Washer- #8 x 3/8"
32	823-3551	Housing, Tilt
33	210-1288	Joiner Strip
34	810-2092	Hanger, Basket
35	809-0171	Thumbscrew, ¼ x 1-3/8" Nickel-Plated
* Not Illustrated		

2.3.3 Door Components – Spring-Loaded Door Pins

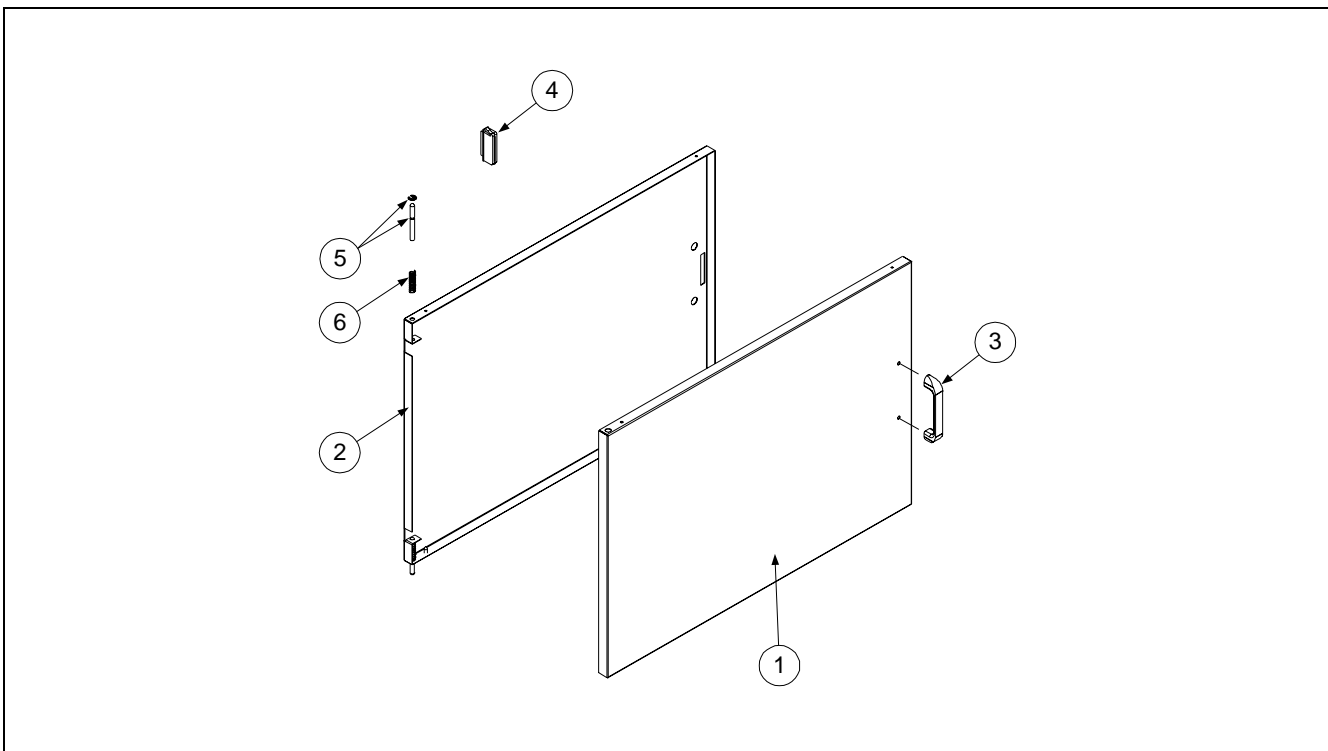

Item	Part #	Description
1	824-1146	Panel, Door- Outer (Current Production UE Only)
2	200-4610	Liner, Door (Current Production UE Only)
3	810-0180	Handle, Door (See Section 2.3.1 and 2.3.2 for connecting hardware)
4	810-1105	Magnet, Door (Offset)
5	106-0554SP	Pin, Door Slotted (With Keeper)
6	810-0275	Spring, Door Hinge
* Not Illustrated		

ULTIMATE ELECTRIC SERIES FRYERS CHAPTER 2: PARTS LIST

2.3.4 Top Cap and Tilt Housing Components

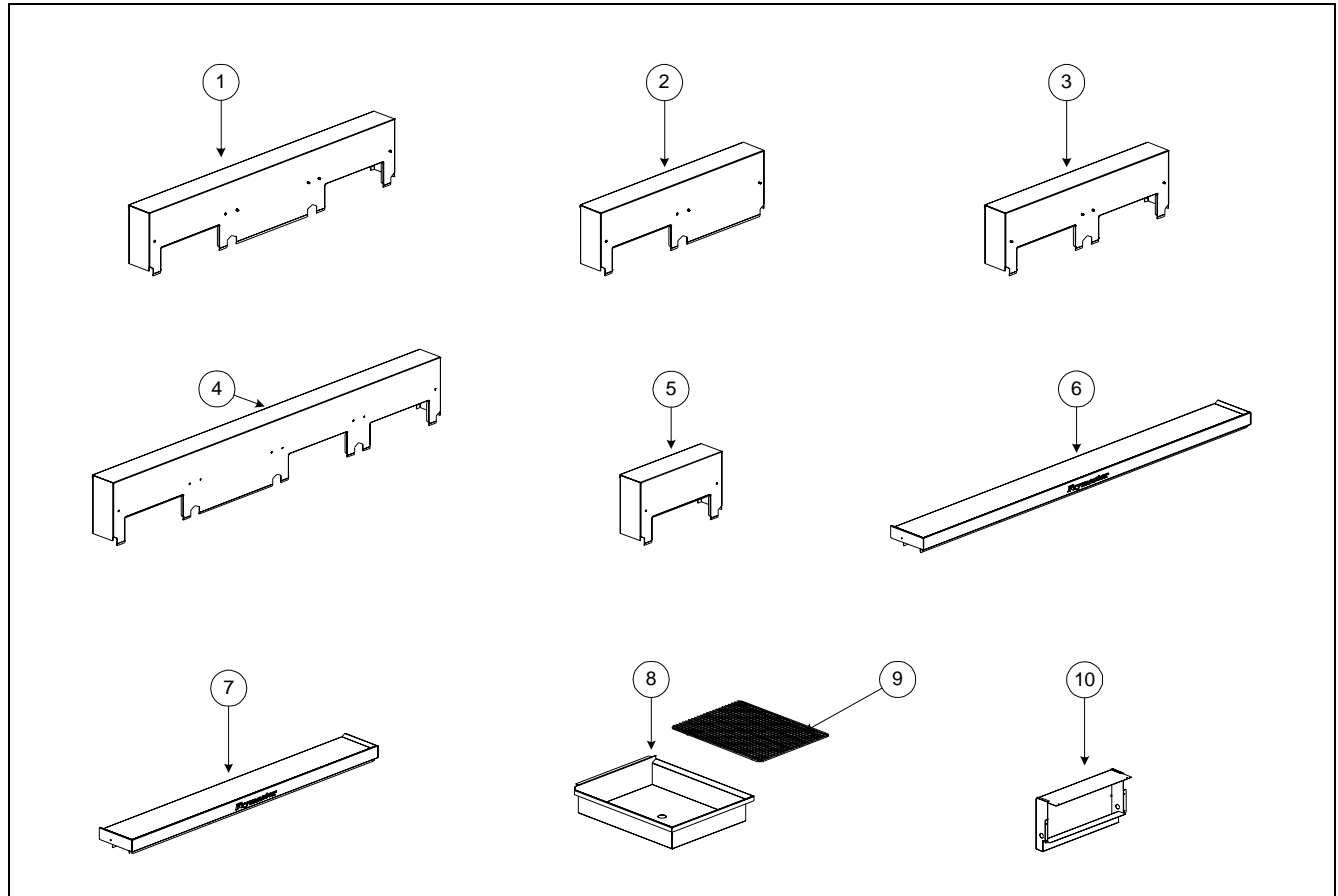

Item	Part Number	Description
1	106-1722SP	Tilt Housing (With Nutsert), 2-Battery EH1721 W/Dump Station
2	106-1723SP	Tilt Housing - EH1721 W/Dump Station
3	823-3551	Tilt Housing, 2-Battery EH1721
4	824-0946	Tilt Housing, 3-Battery EH1721 W/Dump Station
5	823-3855	Tilt Housing, BIH/EH1721- Single
6	824-0944	Top Cap, 4-Battery EH1721
7	824-0945	Top Cap, 3-Battery EH1721
8	823-3436	Dump Station, EH1721
*	823-2335	Strainer (Screen), Dump Station Drain
9	803-0310	Grid, Dump Station
10	106-1724SP	Cover Assy, Dump Station- Front
* Not Illustrated		

ULTIMATE ELECTRIC SERIES FRYERS
CHAPTER 2: PARTS LIST

2.4 Computers, Controllers and Related Components

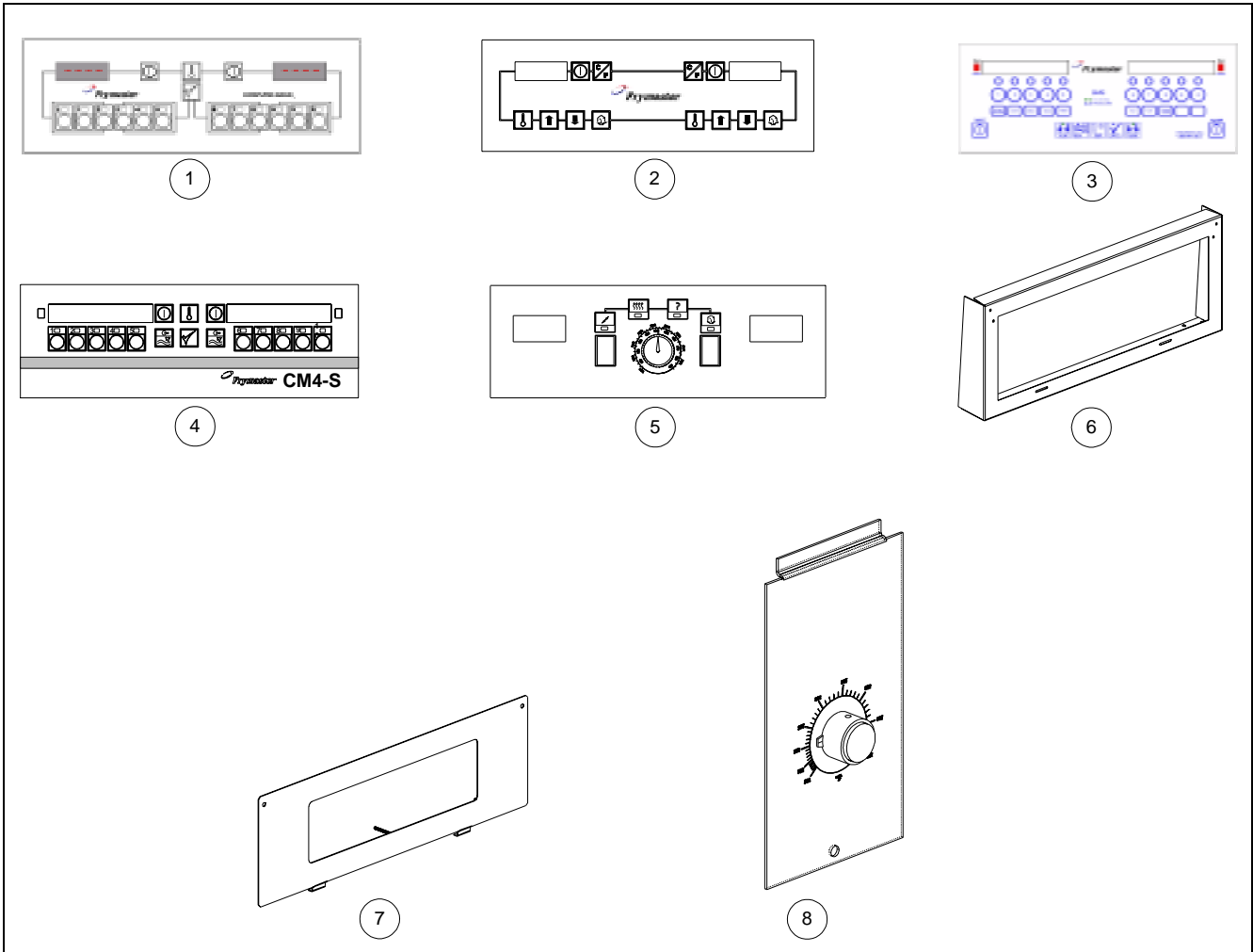

**ULTIMATE ELECTRIC SERIES FRYERS
CHAPTER 2: PARTS LIST**

2.4 Computers, Controllers and Related Components (cont.)

Item	Part Number	Description
		All Computers/Controllers Come With Bezels Except Item #5
1	106-1827	Computer, CM-III Full-Vat
2	106-1503	Controller, Digital- Full-Vat
*	106-2510	Controller, Digital- Full-Vat- CE
3	106-0063	Computer, KFC-1 Electric (Non-CE)
*	106-0064	Computer, KFC-1 Electric (CE)
4	106-3028	Computer, CM4-S (Segmented Programming)
5	806-7422	Controller, Analog- Solid State (3 On, 12 Off)
6	210-1256	Control Panel- <u>All Ultimate Electrics</u>
7	823-3433	Bezel, Computer- <u>All Except KFC18E</u>
*	823-2882	Bezel, Computer- <u>KFC18E Only</u>
8		Electronic Thermostat Controller
	210-1985	Faceplate, Potentiometer Assembly- 18UE
	802-2052	Label, Faceplate- Electronic Thermostat Controller
	106-0801SP	Pot Assy, Electronic Thermostat Controller- 18UE
	816-0534	Knob, Pot Assy- Electronic Thermostat Controller- 18UE
* Not Illustrated		

ULTIMATE ELECTRIC SERIES FRYERS
CHAPTER 2: PARTS LIST

2.5 Contactor/Wireway Box and Related Components

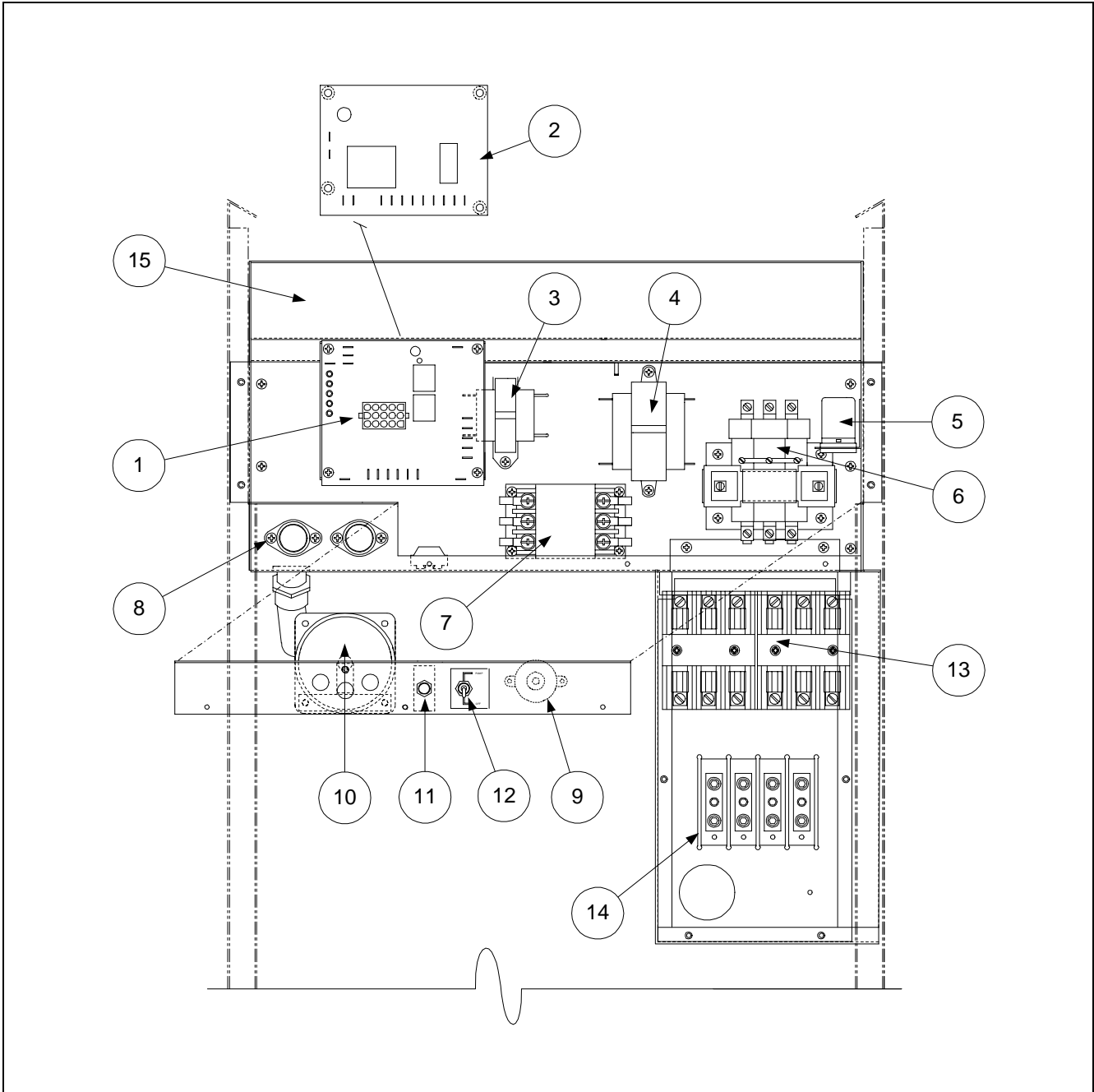

**ULTIMATE ELECTRIC SERIES FRYERS
CHAPTER 2: PARTS LIST**

2.5 Contactor/Wireway Box and Related Components (cont.)

Item	Part Number	Description
1	806-6336	Interface Board- (All Except Electronic Thermostat Controller)
2	807-3722	Interface Board- (Electronic Thermostat Controllers Only)
3	807-0855	Transformer, 120V, 50/60 Hz –12V 20VA (480V Units)
*	807-0979	Transformer, 208-240V, 50/60Hz –12V 20VA
4	807-0800	Transformer, 120V 50/60 Hz –24V 50VA (480V Units)
*	807-0680	Transformer, 208-240V, 50/60Hz –24V 20VA
5	807-3611	Relay, 24VAC
6	807-1071	Contactor, Mercury- 240VAC 30-Amp (17 kW Units)
*	807-0884	Contactor, Mercury- 240VAC 50-Amp (21 kW Units)
7	810-1202	Contactor, Latching- 40-Amp, 3-Pole
8	807-0922	Fuse Holder, Buss Fuse
*	807-2278	Fuse, 20-Amp
9	806-3660	Sound Device- <u>All Except KFC18E</u>
10	806-3660	Speaker, Sound- <u>KFC18E Only</u>
11	807-3538	Breaker, Circuit- 5 Amp (230V Filter Circuit)
*	807-3577	Breaker, Circuit- 7 Amp (120V Filter Circuit)
12	807-3539	Switch, Toggle- Filter Bypass- ON-OFF
13	807-0501	Fuse Block, Buss #2968, 3-Pole
14	807-2465	Power Block– 3-Phase- WYE Only
*	807-3610	Power Block– 3-Phase- DELTA Only
15	823-3458	Wireway Control Panel (Box)- <u>All Ultimate Electrics</u>
*	816-0570	Cover, Wireway Control Box (Clear Lexan)
*	807-0331	Transformer, 480V-250VA (With Basket Lift)
*	807-0064	Transformer, 480V-150VA (Without Basket Lift)
*	807-0800	Transformer, 120V 50/60 Hz -24V 50VA (UFF 100 Pump Motor Relay)
*	807-0680	Transformer, 208V, 50/60Hz –24V 20VA (UFF 100 Pump Motor Relay)
*	824-0955	Cover, 480V Transformer- Left Side
*	200-1291	Cover, Terminal Block- <u>All Except Electronic Thermostat Controller</u>
*	18-0350-1	Cover, Terminal Block- <u>Electronic Thermostat Controller Only</u>
* Not Illustrated		

ULTIMATE ELECTRIC SERIES FRYERS
CHAPTER 2: PARTS LIST

2.6 Filter Pan and Related Components- Built-in Filtration

2.6.1 Under Fryer Filter (UFF) – UFF 80 (100 Lb Capacity)

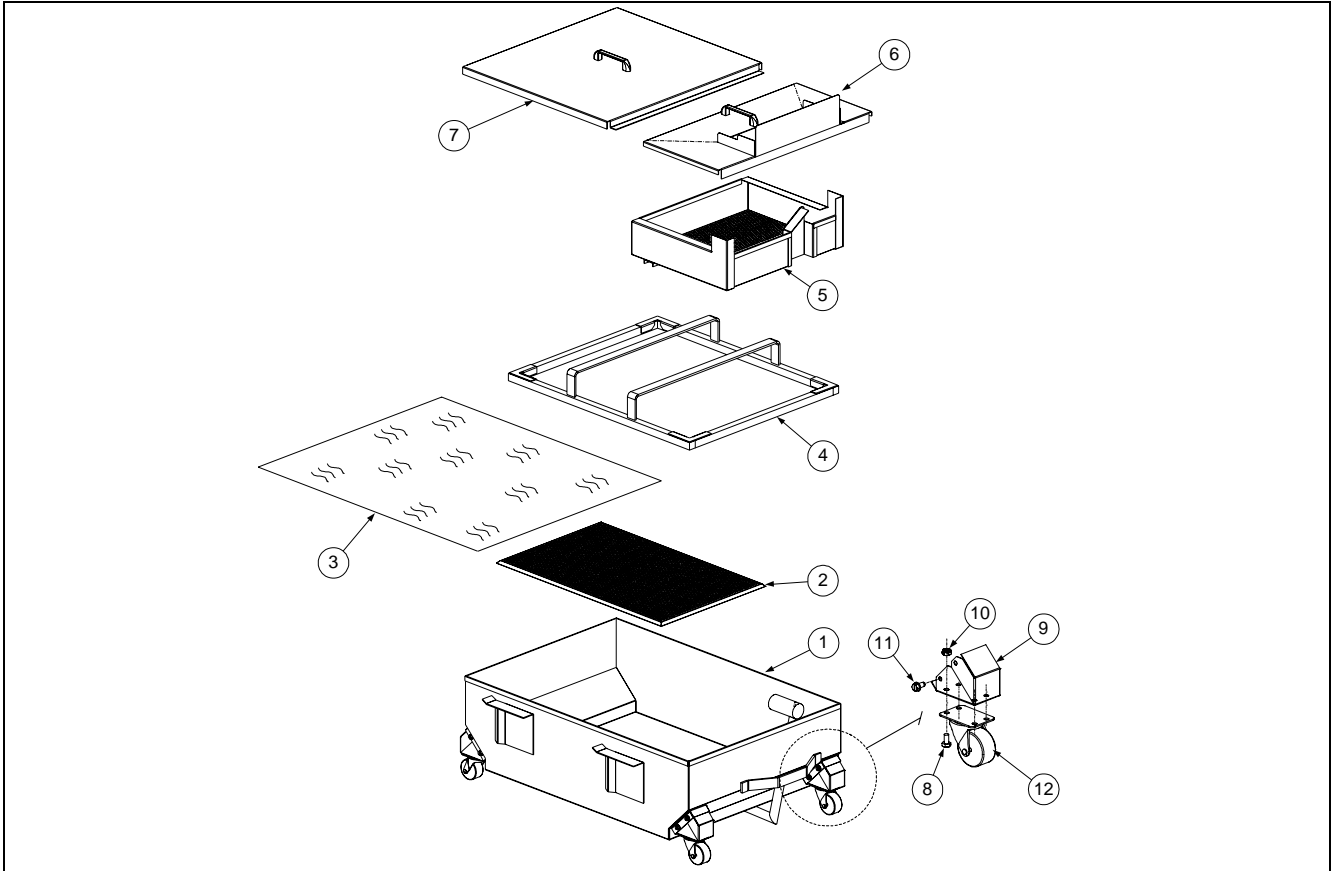

Item	Part Number	Description
1	106-1584SP	Filter Pan, UFF 80 (100 Pound Capacity)
2	823-3365	Support Grid (Bottom Pan Screen)
3	803-0303	Filter Paper, 26 x 34" (100 Sheets)
4	823-3439	Hold-down Ring, Weighted
5	823-3443	Crumb Basket
6	106-1587SP	Filter Pan Cover, Front
7	106-1588SP	Filter Pan Cover, Back
8	809-0822	Bolt, ¼-20 x ½" Steel
9	210-2291	Insert, Caster
10	809-0820	Nut, Oval Locking- ¼-20
11	809-0805	Screw, ¼-20 x ½"
12	810-0006	Caster, 2"

ULTIMATE ELECTRIC SERIES FRYERS

CHAPTER 2: PARTS LIST

2.6.2 Under Fryer Filter (UFF) – KFC18E Only

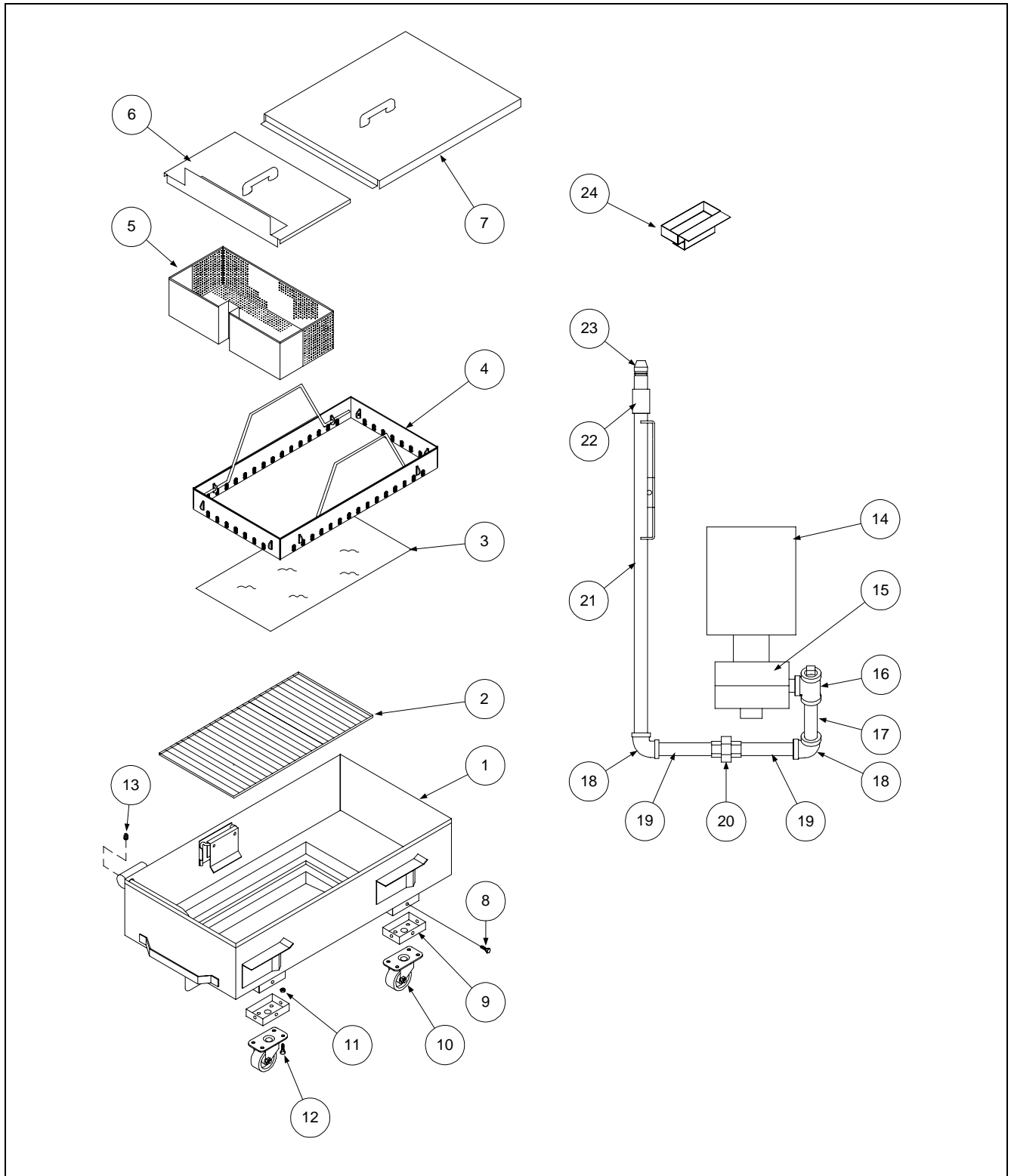

**ULTIMATE ELECTRIC SERIES FRYERS
CHAPTER 2: PARTS LIST**

2.6.2 Under Fryer Filter (UFF) – KFC18E Only (cont.)

Item	Part Number	Description
1	823-3240	Pan, Filter- KFC18E
2	810-2119	Grid, Filter- KFC18E
3	803-0170	Paper, Filter- 16-½ x 25-¾" (100 Sheets)
4	823-3201	Ring, Hold-Down (No Handles)- KFC18E
*	823-3202	Handle, Hold-Down Ring- KFC18E
5	823-3204	Crumb Basket- KFC18E
6	106-0903SP	Lid, Filter Pan- Front
7	106-0905SP	Lid, Filter Pan- Back
8	809-0866	Screw, SS- ¼-10 x ½" Phillips Head
9	210-1293	Insert, Mounting Plate- Caster
10	810-0006	Caster, 2"
11	809-0823	Nut, Nylock- ¼-20
12	809-0822	Bolt, ¼-20 x ½" Hex Head
13	813-0679	Plug, SS- 1/8 Square Head
14	810-2100	Motor, Filter Pump- 120/230V 1/3 HP
15	810-2098	Pump, Filter- 8GPM
16		Fitting, Oil Suction Start
	813-0022	Nipple, ½" NPT x Close BM
	813-0003	Tee, ½" NPT BM
	813-0156	Plug, ½" NPT BM
17	813-0674	Nipple, ½ NPT x 7-¼"
18	813-0062	Elbow, ½" x 90°
19	813-0247	Nipple, ½ NPT x 3-½"
20	813-0173	Union, ½" NPT BM
21	823-3282	Tube, Suction Assembly
22	813-0608	Coupling, Full
23	810-0697	Disconnect, Male
*	826-1392	O-Ring, Disconnect (Qty: 5)
24	106-0820SP	Drip Cup Assembly
* Not Illustrated		

**ULTIMATE ELECTRIC SERIES FRYERS
CHAPTER 2: PARTS LIST**

2.6.3 Under Fryer Filter (UFF) – Filter-Leaf /Suction Tube Assembly

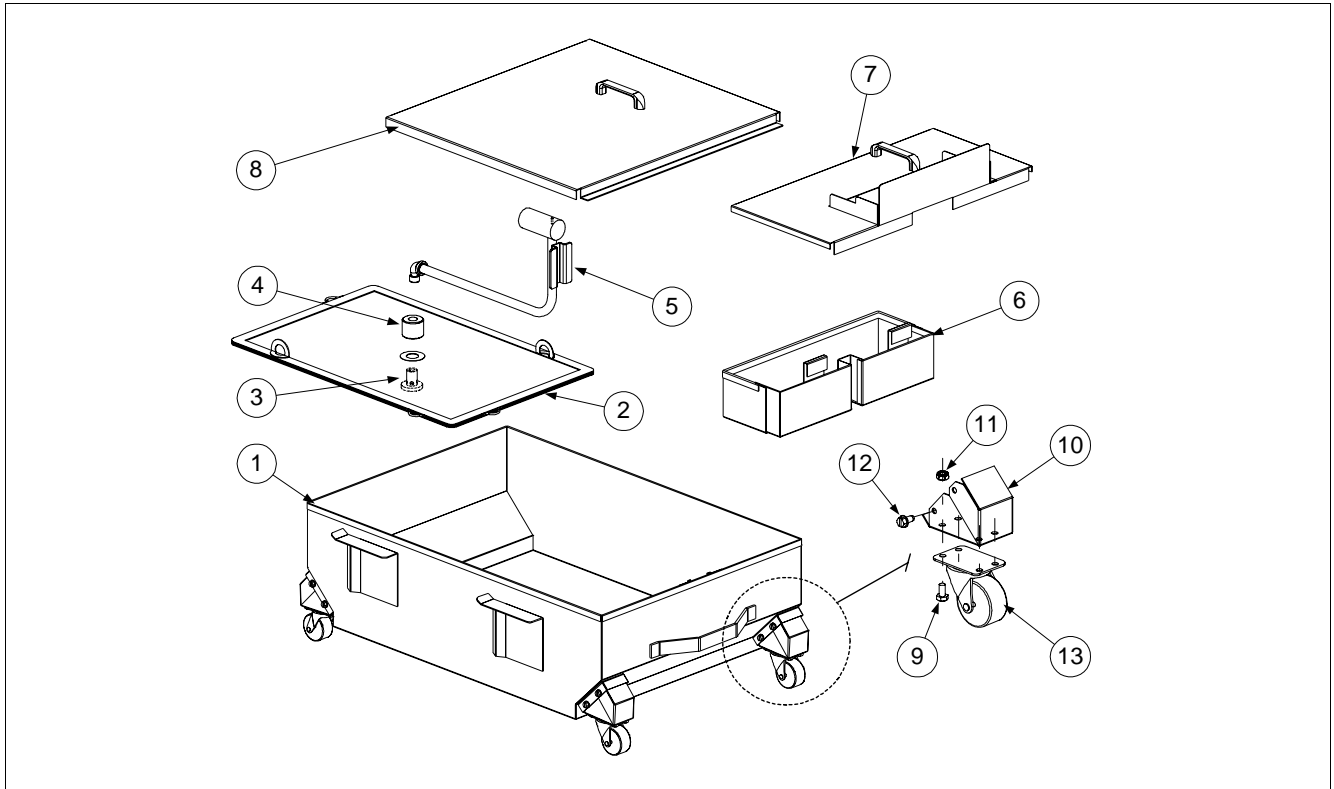

Item	Part Number	Description
1	823-4184	Filter Pan, UFF 80- Filter-Leaf Equipped
2	810-2350	Filter Leaf
3	810-2583	Fitting, Bottom- Filter Leaf
4	810-2582	Fitting, Upper- Filter Leaf
5	823-4112	Suction Tube Assembly- Filter Leaf
*	813-0679	Plug, 1/8 Square S/S (Suction Port)
6	823-3443	Crumb Basket
7	106-2953SP	Filter Pan Cover, Front
8	106-2952SP	Filter Pan Cover, Back
9	809-0822	Bolt, ¼-20 x ½" Steel
10	210-2291	Insert, Caster
11	809-0820	Nut, Oval Locking- ¼-20
12	809-0805	Screw, ¼-20 x ½"
13	810-0006	Caster, 2"
* Not Illustrated		

ULTIMATE ELECTRIC SERIES FRYERS
CHAPTER 2: PARTS LIST

2.6.4 Single Under Fryer Filter (SUFF) – BIH1721 and 18UE

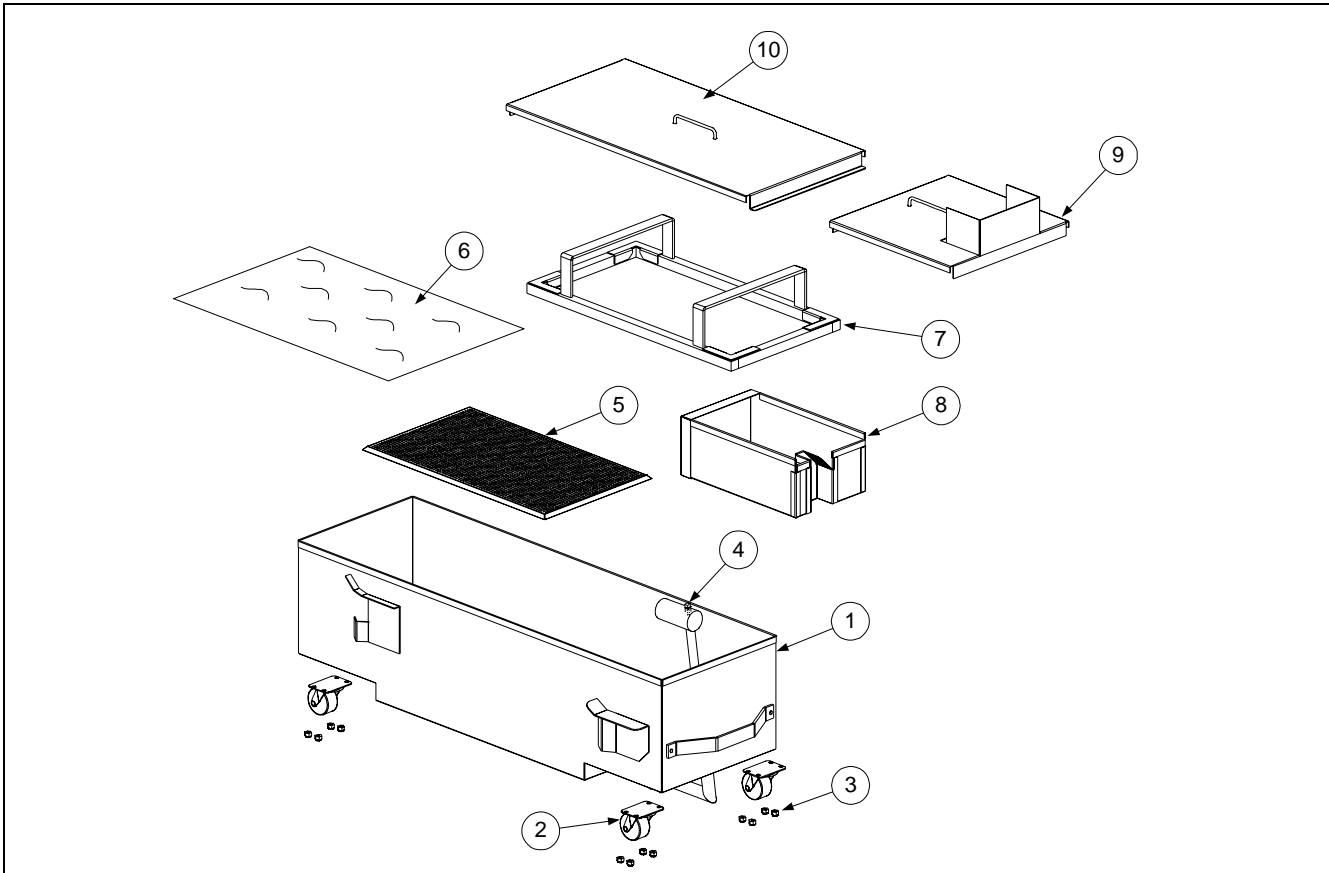

Item	Part Number	Description
1	106-2225SP	Filter Pan, SUFF 60 BIH1721 and 18UE
2	810-2141	Caster, 2"-Swivel
3	809-0823	Nut, Nylock ¼-20
4	813-0679	Plug, 1/8" SS Square Head
*	813-0684	Plug, Hex Socket, 3/8" NPT
5	823-3769	Support Grid (Bottom Pan Screen)- SUFF 60 BIH1721
6	803-0289	Paper, Filter- 22 x 34"
7	823-3768	Hold-Down Ring, Weighted- SUFF 60 BIH1721
8	823-3736	Crumb Basket
9	823-3766	Filter Pan Cover, Front
10	823-3767	Filter Pan Cover, Back
* Not Illustrated		

ULTIMATE ELECTRIC SERIES FRYERS
CHAPTER 2: PARTS LIST

2.7 Frypot and Drain Valve Components

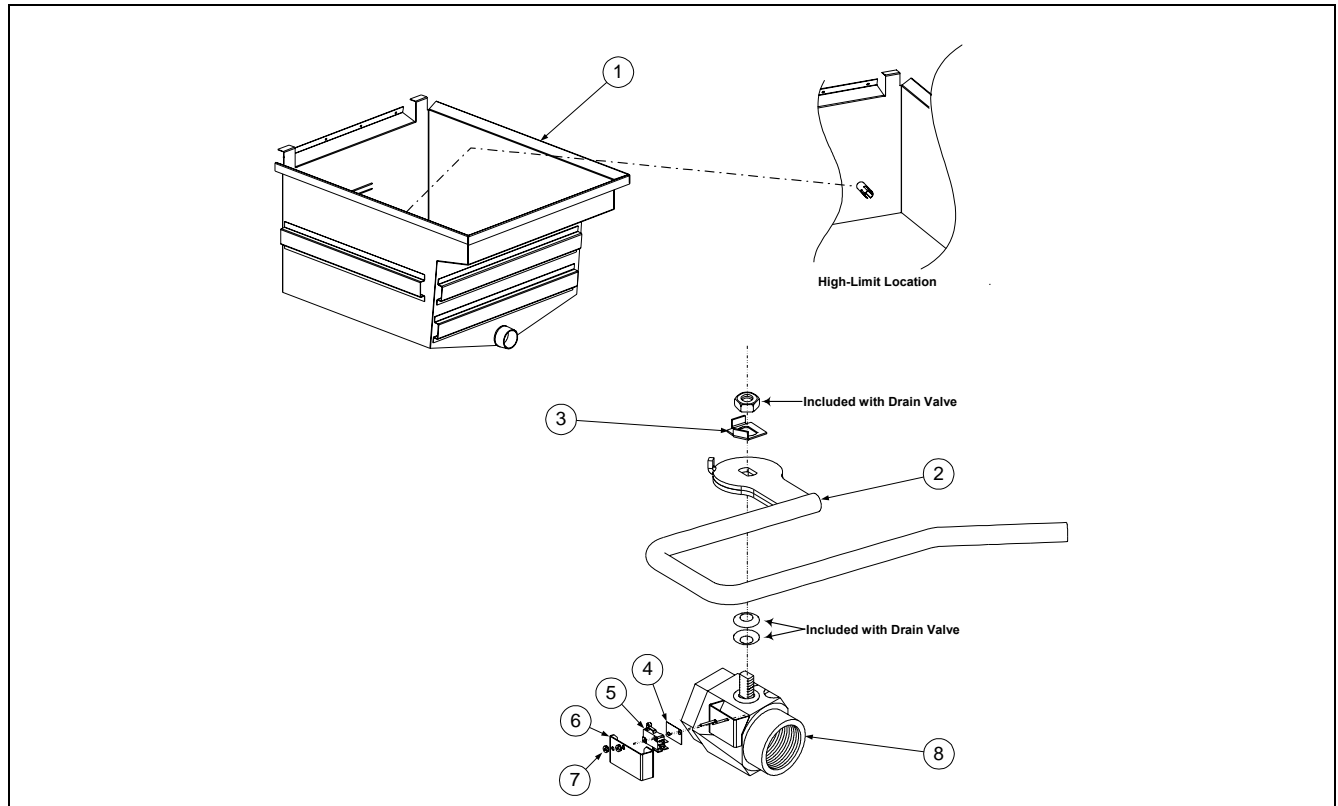

Item	Part Number	Description
1	823-3235	Frypot- EH1721, 18UE & 18E
*	823-4290	Frypot- EH1721 With 3 Oil-Level Lines
2	823-4233	Handle, Drain Valve- Filter Units Only
*	823-4187	Handle, Drain Valve- Single Fryers Only
*	816-0547	Cap, Drain Valve Handle- Red
3	200-1257	Retainer, Drain Valve Nut
4	816-0220	Insulation, Microswitch
5	807-2104	Microswitch (Domestic and CE)
6	210-1269	Guard, Drain Valve Microswitch
7	809-0237	Nut, 4-40 Keps Hex- With External Teeth
8	823-3236	Drain Valve- 1-½" Full Port W/ Microswitch Bracket
* Not Illustrated		

ULTIMATE ELECTRIC SERIES FRYERS
CHAPTER 2: PARTS LIST

2.8 Oil Drain Flush Components

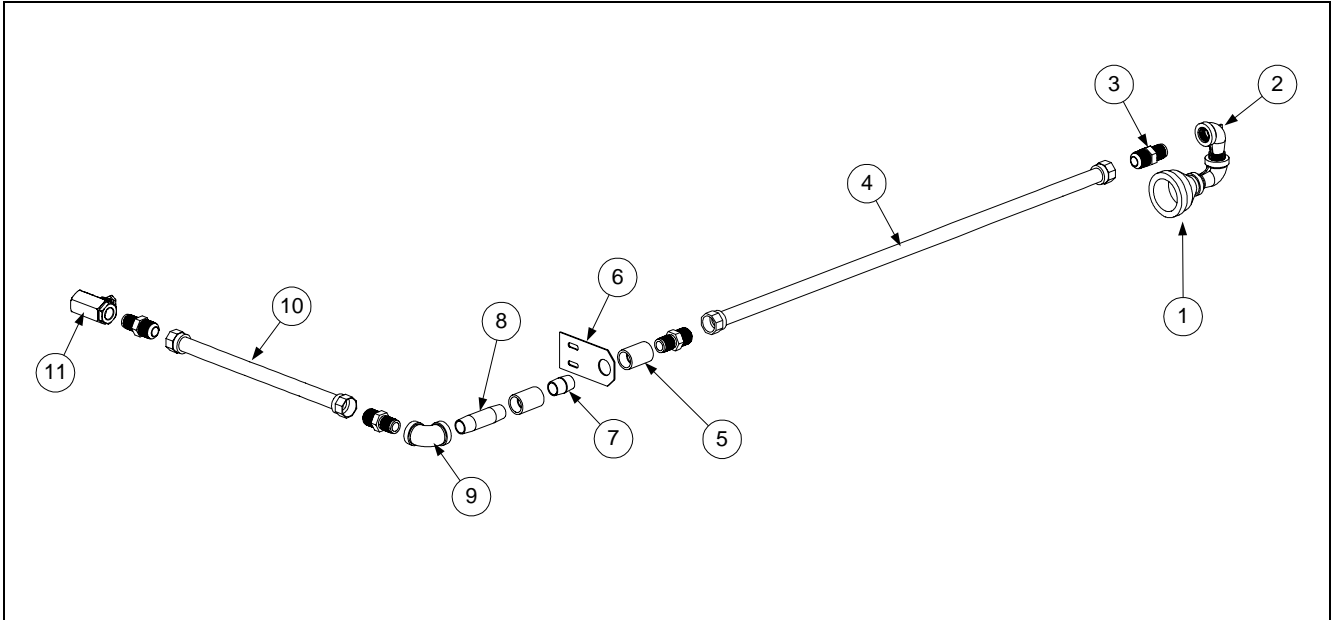

Item	Part Number	Description
1	813-0686	Bell Reducer, 1-½ x ½"
2	813-0165	Elbow, Street- ½ x ½" 90°
3	810-1668	Adapter, Male- 5/8 O.D. x ½"
4	810-1069	Flexline, 5/8 x 29-½"
5	813-0051	Coupling, Full- ½" NPT BM
6	900-1958	Bracket, Flush Line Support
7	813-0022	Nipple, ½" x Close NPT BM
8	813-0460	Nipple, ½ x 3" NPT BM
9	813-0062	Elbow, ½" 90° NPT BM
10	810-1057	Flexline, 5/8 x 13"
11	810-0278	Valve, Ball- ½"
*	823-3481	Handle, Oil Flush Valve
*	816-0549	Cap, Oil Flush Valve Handle- Blue
*	807-1419	Heater Strip- 240V/45W 36" L
* Not Illustrated		

**ULTIMATE ELECTRIC SERIES FRYERS
CHAPTER 2: PARTS LIST**

2.9 Oil Drain Manifold Components

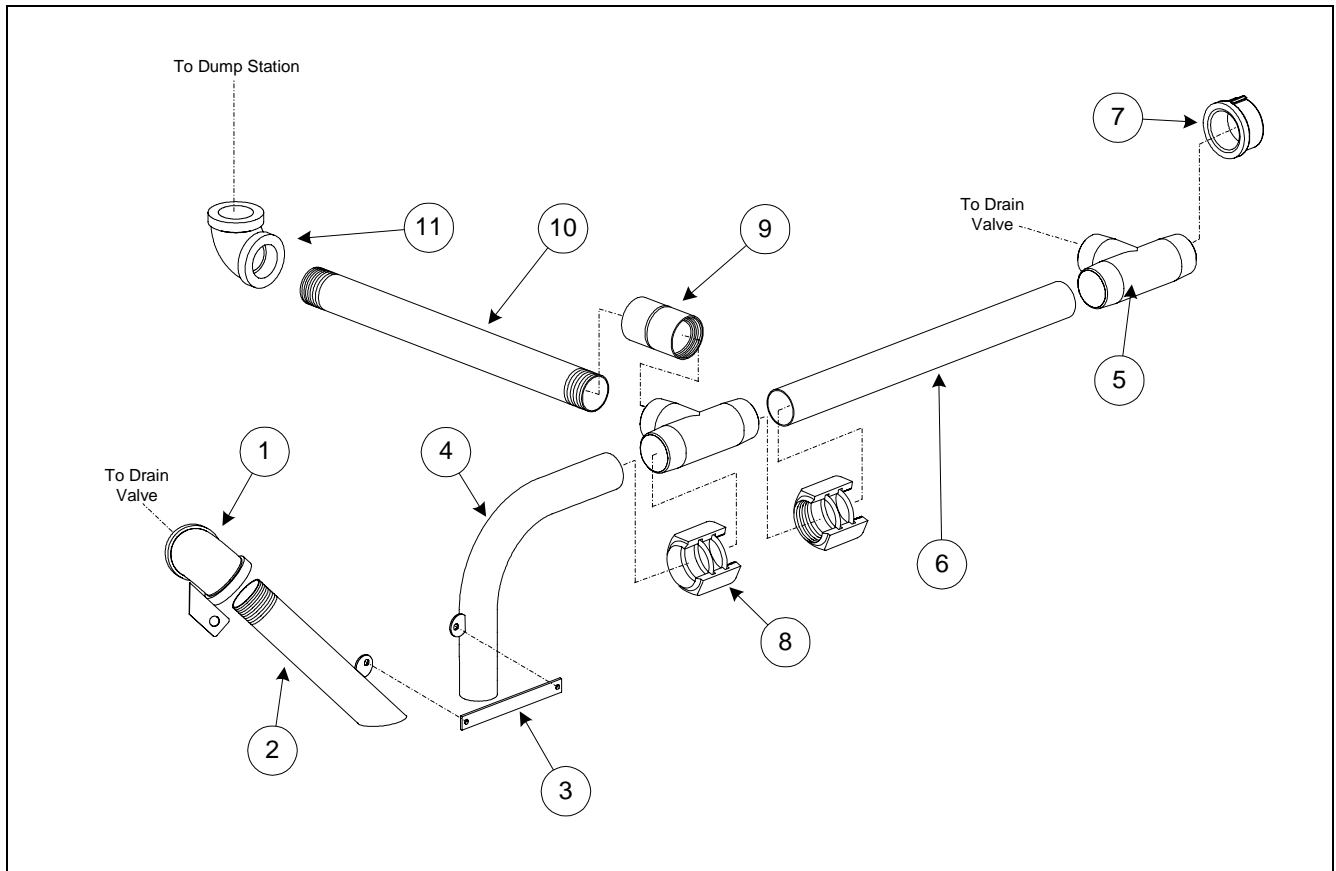

Item	Part Number	Description
1	823-3221	Elbow, with Bracket (Drain Valve Handle)
2	823-3558	Drain Pipe, Left Side
3	210-2311	Clamp, Center- Drain Pipe
4	823-3441	Drain Pipe, Right Side
5	813-0722	Tee, 1-½" NPT Male x 5-½" Long
6	200-1840	Drain Manifold Tube
7	813-0659	Pipe Cap, 1-½" NPT BM
8	809-0884	Nut, Slip Joint- 1-½"
*	816-0544	O-ring (Slip-Joint Nut)
9	813-0818	Coupling, Full 1-½"-SS
10	813-0723	Nipple, 1-½" x 8" NPT BM
11	813-0667	Elbow, 1-½" x 90° SS

* Not Illustrated

ULTIMATE ELECTRIC SERIES FRYERS

CHAPTER 2: PARTS LIST

2.10 Oil Return Manifold, Motor and Pump Components

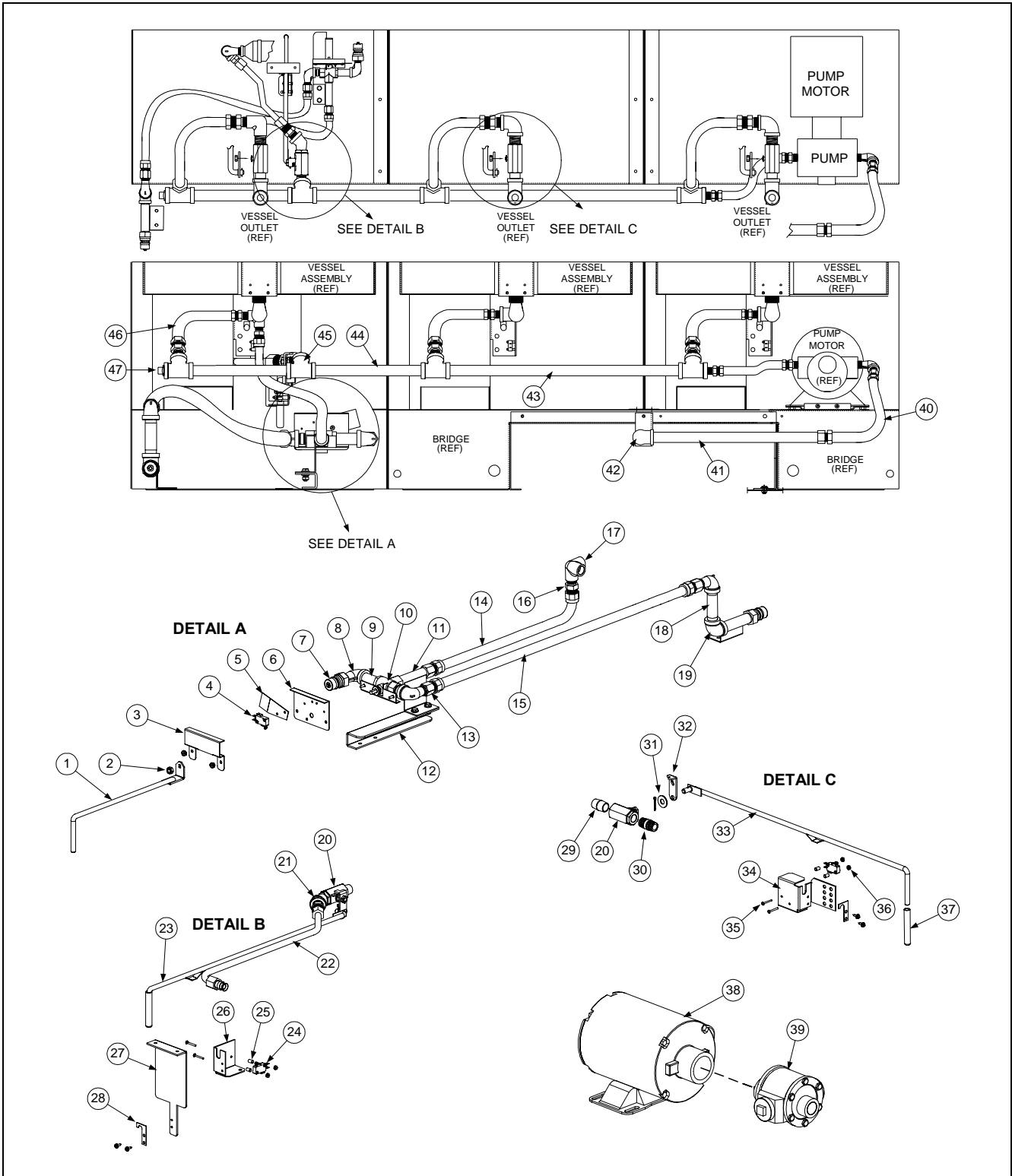

**ULTIMATE ELECTRIC SERIES FRYERS
CHAPTER 2: PARTS LIST**

2.10 Oil Return Manifold, Motor and Pump Components (cont.)

Item	Part Number	Description
		NOTE: Oil Return Components Will Vary From System To System- The Most Common Components Are Included Below
		Rinse Hose/Disposal Plumbing Components
1	823-4234	Handle, 3-Way Valve- Wand/Dispose
2	809-0056	Nut, 5/16-18 Hex
*	809-0681	Washer, Nylon- .340 ID, .740 OD
*	809-0194	Washer, Flat- 5/16" SAE
3	900-2110	Cover, Microswitch
*	809-0256	Nut, Microswitch Cover
4	807-2104	Microswitch, Roller
5	812-0442	Insulation, Microswitch Switchbox
6	900-2112	Support, Microswitch Mount
7	810-0487	Coupling Disconnect- Male
8	813-0165	Elbow, Street- ½" 90° NPT BM
9	813-0265	Nipple, ½ x 2-½" NPT BM
10	810-1003	Valve, Ball- Three-Way 180°
11	823-4196	Nipple Weld Assembly- Three-Way Valve
12	200-4996	Bracket, Mounting Base
*	809-0131	Screw, ¼-20 x ¾" Hex Head
*	809-0070	Nut, ¼-20 Hex S/S
13	810-1669	Adapter, Female- 5/8 OD x ½"
14	810-1369	Flexline, 5/8 x 17-½"
15	810-1069	Flexline, 5/8 x 29-½"
16	810-1668	Adapter, Male- 5/8 OD x ½"
17	813-0331	Elbow, Side Outlet- ½" NPT
18	813-0247	Nipple, ½ x 3-½" NPT BM
19	813-0062	Elbow, ½" 90° NPT BM
		Drain Flush Components- 3-Battery & Larger Units
20	810-0278	Valve, Ball- ½"
21	813-0342	Elbow, ½" 45° NPT BM
22	810-2626	Tubing, Flare- Oil Return- 3-Battery Church's
* Not Illustrated		

**ULTIMATE ELECTRIC SERIES FRYERS
CHAPTER 2: PARTS LIST**

2.10 Oil Return Manifold, Motor and Pump Components (cont.)

Item	Part Number	Description
23	823-4220	Handle, Drain Flush Valve
*	816-0549	Handle, Vinyl- Blue (Drain Flush/Rinse/Dispose Valve)
24	807-2104	Microswitch (Same as Item #4)
25	810-2144	Spacer, Microswitch
26	200-5056	Bracket, Microswitch- Drain Flush
27	210-5057	Bracket, Main Mount- Microswitch Drain Flush
28	200-1341	Bracket, Microswitch Rod
		Oil Return Valve/Handle Components
29	813-0022	Nipple, ½" x Close NPT BM
30	813-0087	Nipple, ½ x 1-½" NPT BM
31	809-0885	Washer, 3/8 x 1 x .083"
*	809-0843	Pin, Cotter (For Retaining Washer/Rod to Arm)
32	901-0883	Arm, Oil Return Valve
33	823-3238	Handle Assembly, Oil Return
34	202-1233	Bracket, Oil Return Microswitch
35	809-0846	Screw, 4-40 x 1" Slotted
36	809-0237	Nut, Keps- 4-40 (With External Teeth)
37	816-0548	Handle, Vinyl- Yellow (Oil Return)
38	810-2100	Motor, Filter Pump- 120V/230V 1/3 HP
39	810-2098	Pump, Filter- 8GPM
40	810-1159	Flexline, 5/8 x 5"
41	813-0429	Nipple, ½ x 13" NPT BM
42	▶▶▶	See Oil Return Line Assemblies, Section 2.11
43	813-0381	Nipple, ½ x 18-½" NPT BM
44	813-0673	Nipple, ½ x 8-½" NPT BM
45	813-0003	Tee, ½" NPT BM
46	810-1680	Flexline, 5/8 x 6-½"
47	813-0156	Plug, ½" NPT BM Hex Head
* Not Illustrated		

ULTIMATE ELECTRIC SERIES FRYERS
CHAPTER 2: PARTS LIST

2.11 Oil Return Line Assemblies

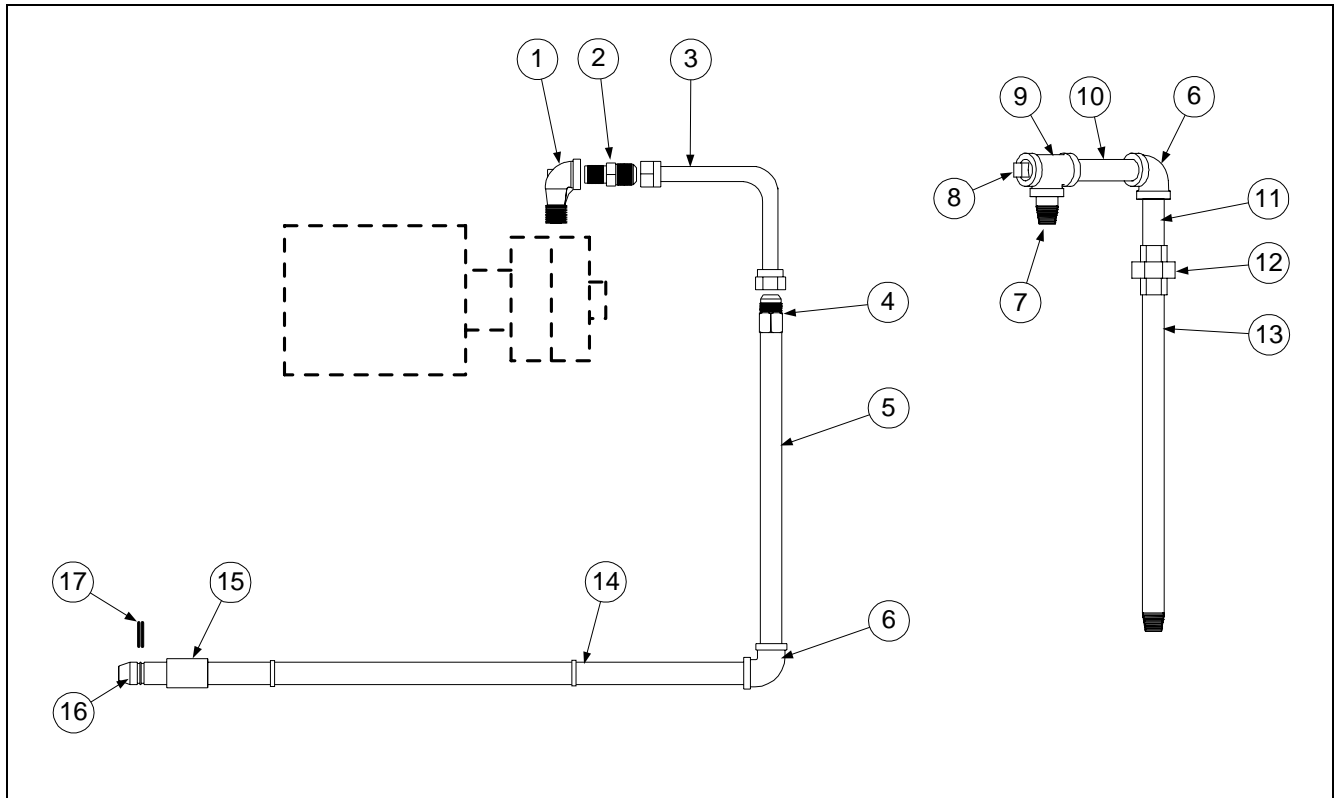

Item	Part Number	Description
		<i>Oil Return Line Assemblies Will Vary From System To System- Use The Above Illustration To Identify Components</i>
1	813-0165	Elbow, Street- ½" 90°
2	810-1668	Adapter, Male- 5/8 x ½"
3	810-1159	Flexline, 5/8 x 5"
4	810-1669	Adapter, Female- 5/8 x ½"
5	813-0429	Nipple, ½ x 13" NPT BM
6	813-0062	Elbow, ½" 90° NPT BM
7	813-0609	Nipple- ½ NPT x 1"
8	813-0156	Plug, ½" NPT Hex Head
9	813-0003	Tee, ½" NPT BM
* Not Illustrated		

**ULTIMATE ELECTRIC SERIES FRYERS
CHAPTER 2: PARTS LIST**

2.11 Oil Return Line Assemblies (cont.)

Item	Part Number	Description
10	813-0281	Nipple- ½ NPT x 5" NPT BM
11	813-0091	Nipple- ½ NPT x 2-½" NPT BM
12	813-0173	Union- ½" NPT BM
13	813-0381	Nipple- ½ NPT x 18-½" BM
14	823-3562	Tube, Suction
15	813-0608	Coupling- ½" NPT- Full
16	810-0697	Disconnect, Male
17	826-1392	O-ring, Suction Tube- 2 Required (Qty:5)
*	806-5932	Heater Strip- 240V/45W 36" L
* Not Illustrated		

ULTIMATE ELECTRIC SERIES FRYERS
CHAPTER 2: PARTS LIST

2.12 Probes, High-Limits, Elements and Related Components

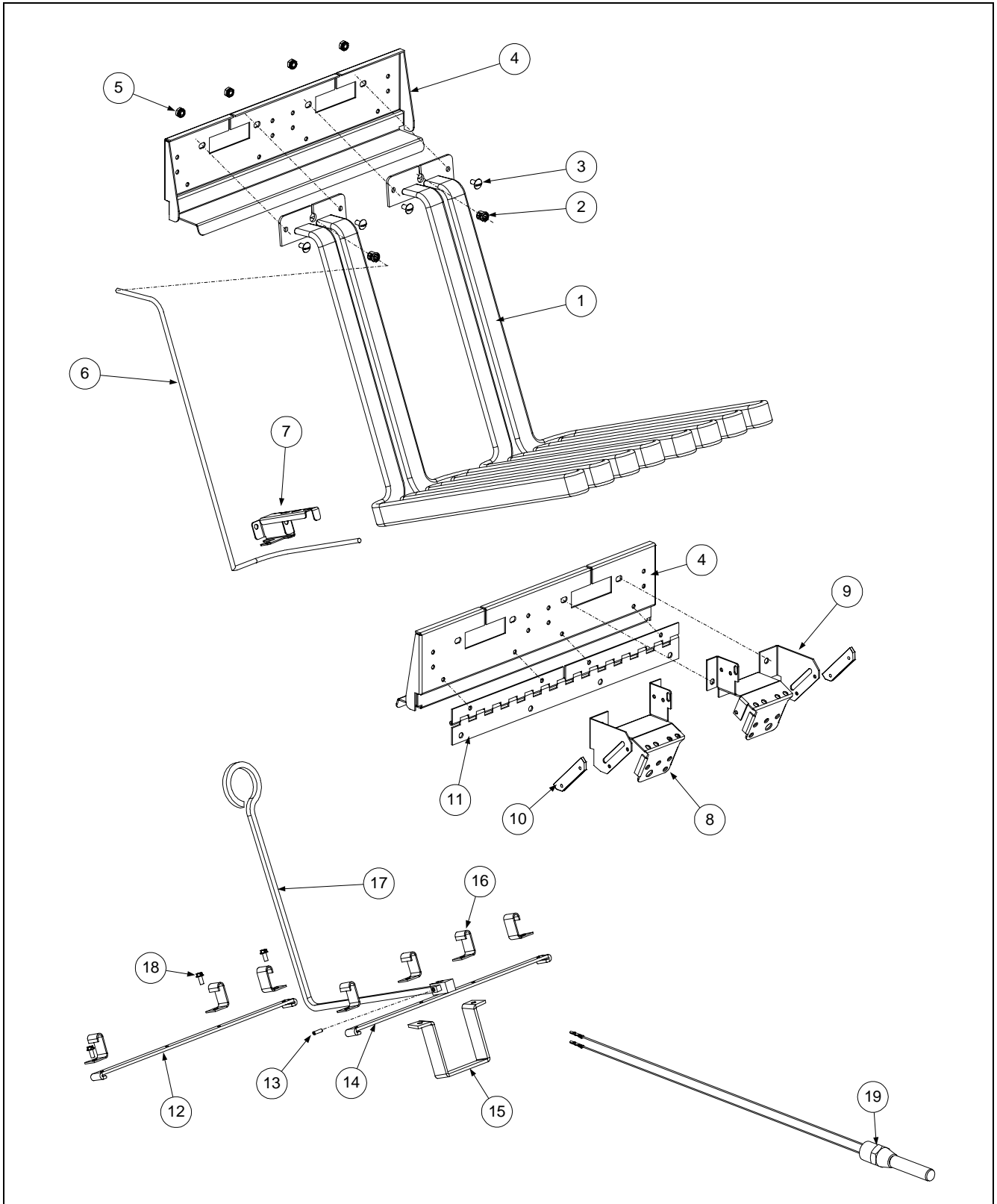

**ULTIMATE ELECTRIC SERIES FRYERS
CHAPTER 2: PARTS LIST**

2.12 Probes, High-Limits, Elements and Related Components (cont.)

Item	Part Number	Description
1	807-3652	Element- 208V 8.5 kW
	807-3675	Element- 480V 10.25 kW
	807-3655	Element- 240V 8.5 kW
	807-3657	Element- 208V 9.0 kW
	807-3658	Element- 240V 9.0 kW
	807-2557	Element- 208V 10.25 kW
	807-3655	Element- 240V 8.5 kW (USE FOR 220V 7 kW)
	807-3660	Element- 220V 8.5 kW
	807-3661	Element- 220V 10.25 kW
	807-3662	Element- 230V 7 kW
	807-3663	Element- 230V 8.5 kW
	807-3664	Element- 230V 10.25 kW
	807-2637	Element- 240V 10.25 kW
	807-3660	Element- 220V 8.5 kW (USE FOR 200V 7 kW)
*	807-2137	Connector, Element- Male, 9-Pin
*	807-2138	Connector, Element- Female, 9-Pin
*	807-2135	Connector, Element- Male (High Amp), 6-Pin
*	807-2136	Connector, Element- Female (High Amp), 6-Pin
*	810-2120	Grid, Frypot- Over Element- Full Vat- BIH1721
*	803-0149	Grid, Frypot- FPH1721 Systems
2	826-1339	Bushing, .375 x .188" I.D. (Qty: 10)
3	826-1330	Screw, 10-32 x 3/8" Slotted Head- SS (Qty: 25)
4	210-1313	Tilt Plate
*	900-5378	Bracket, Tilt Plate Spring
*	809-0358	Turnbuckle, Tilt Plate Spring (Early Production Units)
*	810-0297	Spring, Tilt Plate
*	200-2932	Cover, Lower Back Wire
5	826-1376	Nut, Keps- 10-32 Hex (Qty: 10)
6	826-1791	Probe, Temperature- 15" (With Ty Wrap)- <u>All Except Electronic Thermostat Controller</u>
*	807-3653	Probe, Temperature- <u>Electronic Thermostat Controller Only</u>
*	807-1068	Connector, 2-Pin
7	910-5022	Bracket, Probe Guard
* Not Illustrated		

**ULTIMATE ELECTRIC SERIES FRYERS
CHAPTER 2: PARTS LIST**

2.12 Probes, High-Limits, Elements and Related Components (cont.)

Item	Part Number	Description
8	201-1573	Bracket, Element Support- Left Side
9	202-1573	Bracket, Element Support- Right Side
10	816-0214	Nylon Bar, Tilt Plate Spring Bracket (Use .123 x .379" Pop Rivet To Attach)
11	810-0035	Hinge, Tilt- 14" Continuous
12	910-5459	Support, Back- Full-vat Element
13	810-1212	Spring Pin, Heating Element Handle
14	823-2534	Support, Front- Full-vat Element (Without Handle and Spring Pin)
15	210-1610	Support, Bottom- Full-vat Element
16	910-2042	Clamp, Element to Support
17	810-1233	Handle, Lift- Full-vat Element
18	809-0518	Screw, 8-32 x 3/8" Hex Washer Slotted
19	806-8035	High-Limit Thermostat- 435°F
* Not Illustrated		

**ULTIMATE ELECTRIC SERIES FRYERS
CHAPTER 2: PARTS LIST**

2.13 Tilt Safety Switch Components

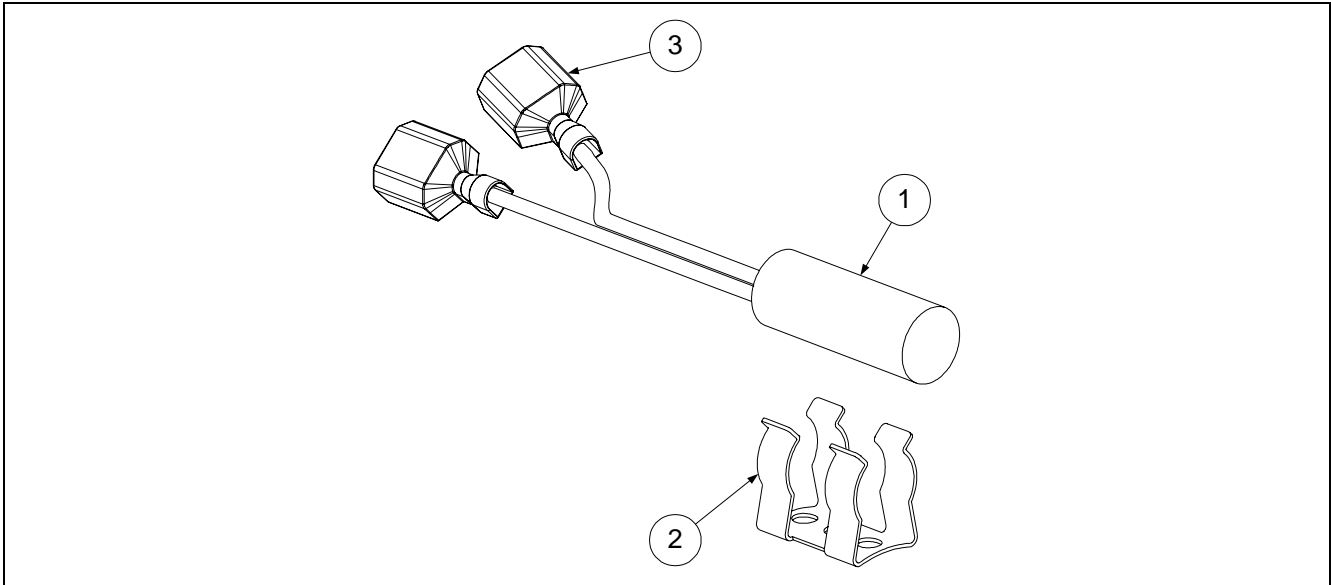

Item	Part Number	Description
1	806-6849SP	Switch, Tilt Safety
*	809-0874	Ty Wrap, Plastic- 4" (Operating Temperature 265°F)
2	807-1570	Clip, Tilt Switch
3	807-1397	Terminal, Push-On- Fully Insulated
*	809-0250	Nut, Keps- 6-32 Hex
*	809-0096	Screw, 6-32 x 5/8"- Binding, Slotted-Head
*	826-1374	Screw, #10-½ - Hex Washer Head (Qty: 25)
*	809-0766	Nut, SS- 10-32
* Not Illustrated		



Frymaster L.L.C./Dean, 8700 Line Avenue, PO Box 51000, Shreveport, Louisiana 71135-1000
Shipping Address: 8700 Line Avenue, Shreveport, Louisiana 71106

TEL 1-318-865-1711

FAX (Parts) 1-318-219-7140

FAX (Tech Support) 1-318-219-7135

PRINTED IN THE UNITED STATES

SERVICE HOTLINE
1-800-551-8633

Price: \$28.00
819-5981
JUNE 2003