

# Micro-Fl<sub>o</sub> Built-In Series Filtration Systems

Installation, Operation & Maintenance Manual



Models MF90-12BI, -14BI, -18BI & -20BI



# DEAN



Dean, a member of the Commercial Food Equipment Service Association, recommends using CFESA Certified Technicians.

**24-Hour Service Hotline 1-800-551-8633**

**Price: \$6.00**

**819-5745  
10-01**

**Please read all sections of this manual and retain for future reference.**

**Installation, maintenance, and repairs should be performed by your Dean  
Factory Authorized Service Center.**

** CAUTION**

**DO NOT STORE OR USE GASOLINE OR OTHER FLAMMABLE VAPORS AND LIQUIDS IN  
THE VICINITY OF THIS OR ANY OTHER COOKING APPLIANCE.**

** WARNING**

**IMPROPER INSTALLATION, ADJUSTMENT, ALTERATION, SERVICE, OR  
MAINTENANCE CAN CAUSE PROPERTY DAMAGE, INJURY OR DEATH. READ THE  
INSTALLATION, OPERATING AND MAINTENANCE INSTRUCTIONS THOROUGHLY  
BEFORE INSTALLING OR SERVICING THIS EQUIPMENT.**

** WARNING**

**SAFE AND SATISFACTORY OPERATION OF YOUR EQUIPMENT DEPENDS ON ITS  
PROPER INSTALLATION. INSTALLATION MUST CONFORM TO LOCAL CODES, OR IN  
THE ABSENCE OF LOCAL CODES, WITH THE LATEST EDITION OF THE NATIONAL  
ELECTRIC CODE, N.F.P.A. 70.**



## Micro-Flo Series Built-In Filters

### TABLE OF CONTENTS

	Page #
1. DESCRIPTION AND SPECIFICATIONS .....	1-1
2. PRE-INSTALLATION .....	2-1
3. RECEIVING & INSTALLING THE FILTER .....	3-1
4. OPERATIONS .....	4-1
5. CLEANING AND MAINTENANCE .....	5-1
6. TROUBLESHOOTING .....	6-1
7. FACTORY SERVICE AND PARTS ORDERING .....	7-1

# MICRO-FLO BUILT-IN SERIES FILTRATION SYSTEMS

## CHAPTER 1: DESCRIPTION AND SPECIFICATIONS

---

Micro-Flo Built-In Series filtration systems are available in sizes to handle quantities of oil up to 120 pounds. They can be fabricated to match Dean gas (Super Marathon & Decathlon) or electric fryers (Cool Zone & Flatbottom Series), or in stand-alone cabinets. Micro-Flo filtration systems incorporate a "gravity drain" design. The oil return line can be configured overhead (prior to 1994), internally plumbed, or returned by the hose & nozzle.

Prior to 1994, handle-operated ball valves or optional "push-pull" linkage-operated ball valve controls located in the filter cabinet were available. Current systems are configured with the oil-return and drain valve controls located in each fryer cabinet.

### 1.1 Construction

Micro-Flo Built-In filters are constructed with the following features:

- ☞ Fully welded, heavy gauge steel, with a removable stainless steel filter pan.
- ☞ Internal oil return lines are plumbed with either a "push-pull" valve system in the filter cabinet or manual drain valves at each fryer.
- ☞ A 1/3 HP motor, coupled with a 5 GPM pump returns filtered oil to the fry vessel. An 8 GPM pump (optional) is also available.

### 1.2 Operating Controls

Micro-Flo Built-In filters are equipped with the following operating controls:

- ☞ The "ON-OFF" power switch is mounted on the front control panel of the filter cabinet. If the filter is equipped with an optional heater, a three-position switch (Heater/Off/Pump) is included as the power switch.
- ☞ Individual fryer drain valves control which fryer is filtered, reducing operator error.
- ☞ Prior to 1994: Oil-return valves are either "push-pull" controls or "lever-operated" manual ball valves; the push-pull controls are in the filter cabinet and the "lever-operated" valves are at each individual fryer.
- ☞ 1994 and later: Oil-return valves are push-pull controls, located within each individual fryer cabinet. A manual "hose-disconnect" valve is located in the filter cabinet.

# MICRO-FLO BUILT-IN SERIES FILTRATION SYSTEMS

## CHAPTER 2: PRE-INSTALLATION

---

### 2.1 General

Micro-Flo Built-In filters are compatible with the following fryer models:

Cool Zone Fryers: Super Marathon and Decathlon Gas Fryers  
Flatbottom Fryers: 1824G and 2424G (gas); 1824E and 2424E (electric)  
Electric Fryers: 714E, 1414E, 1818E, 2020E and 18UE

### 2.2 Standards

Installation must be planned in accordance with all applicable state and local codes.

### 2.3 Dimensions & Capacities

Model	Approximate Oil Capacity (lbs hot)	Filter Paper Size (W x L)
MF90-BI-12	60	11 x 22-5/8"
MF90-BI-14	60	12-5/8 x 22-5/8"
MF90-BI-18	80	16-3/8 x 24-3/8"
MF90-BI-20	108	16-3/8 x 24-3/8"

### 2.4 Electrical Connection

The wiring diagrams are in Section 7 of this manual; the filter may or may not be equipped with a heater probe.

One connection only is required, to a 115v, 60 Hz, 15 amp electrical supply. The unit is equipped with a flexible six foot, 16-3 SJT power cord; if an extension cord is required, it must be a three-conductor grounded cord of at least 16 gauge.

#### **WARNING**

#### **Electrical Grounding Instructions**

**This filter is equipped with a three-prong, grounded plug for your protection against shock hazard, and should be plugged directly into a properly grounded, three-hole receptacle. Do not cut off, remove, or otherwise by-pass the grounding prong on this plug.**

# MICRO-FLO BUILT-IN SERIES FILTRATION SYSTEMS

## CHAPTER 3: RECEIVING & INSTALLING THE FILTER

---

### 3.1 General

Unpack the filter (or the fryer/filter combination) carefully and remove all filter parts from the carton. Do not discard or misplace parts – they will be needed for final assembly.

After unpacking, immediately check the equipment for visible signs of shipping damage. If such damage has occurred, do not refuse shipment. Contact the freight carrier and file the appropriate damage claims. In case of shipping damage, do not contact the factory. The responsibility for shipping damage is between the carrier and the dealer or end-user.

### 3.2 Installation Procedures

Installation must be planned in accordance with all applicable state and local codes, and as follows:

- A. Install casters on fryers/cabinets prior to assembling filter components (where applicable).
- B. Position all fryers/cabinets into their working position without joining, leaving enough space for the filter.
- C. Join fryers on either side of filter with the drain tube in front, and the oil return line in rear.  
  
**Note:** Return oil line may be either rigid pipe or return hose with wand, depending on arrangement ordered. Keep all oil-return line joints loose until full line-up is in place, and then tighten finger tight only.
- D. The drain tube from inboard fryers must terminate in an elbow, with the pipe nipple extending into the filter pan.
- E. Oil return lines are ½-inch steel tubing. Keep all joint fittings loose until the complete fryer/filter battery is assembled and in place.
- F. Connect power to the filter by plugging the filter power supply cord into the appropriate power outlet, located inside the fryer.
- G. Tighten the drain tube connections at the front and the nuts and bolts at the rear. Do not over-tighten the oil return line connections.
- H. Connect the fryer electrical supply to power source.

# MICRO-FLO BUILT-IN SERIES FILTRATION SYSTEMS

## CHAPTER 4: OPERATIONS

---

### 4.1 Initial Installation

On initial installation and before each use, remove all loose parts from the filter, wash the filter pan and all accessories in hot, soapy water and dry thoroughly.

### 4.2 Assembling The Filter Pack

#### 4.2.1 Models Prior to 1994

Micro-Flo filtration systems are shipped with a filter starter kit containing filter paper, filter powder and other accessories. Remove the filter hold-down ring, place two papers on the grid, and then replace the hold-down ring. It is essential that "Dean" filter papers are used; use of other than OEM parts will void the warranty. The remaining filter papers should be stored away from moisture for future use.

The illustration below shows the proper assembly of the filter.

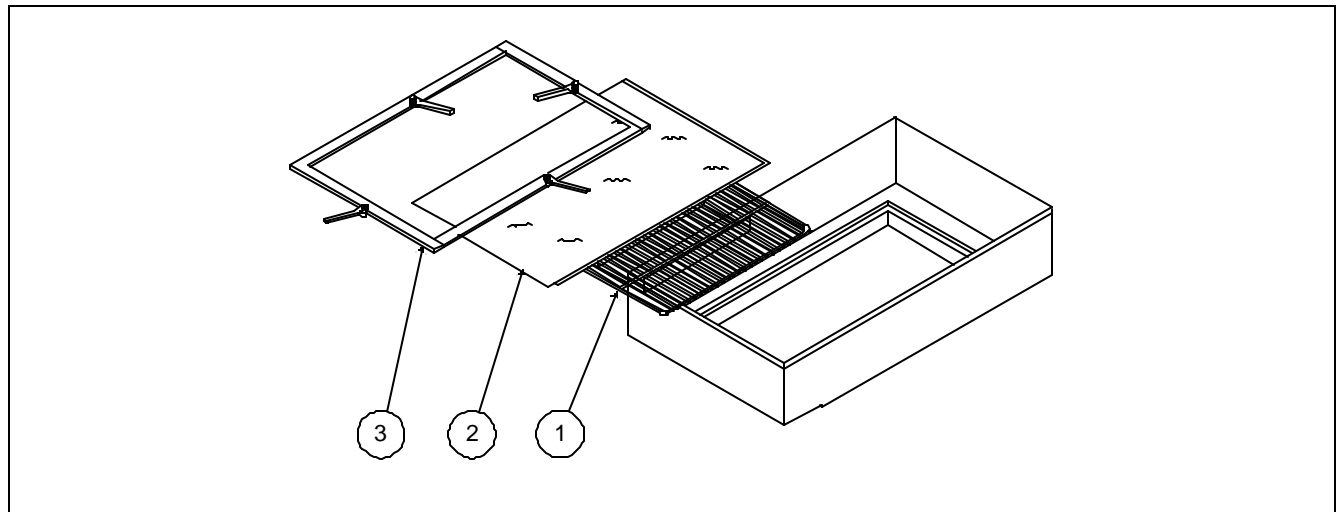

1. Paper support grid
2. Filter paper (2 sheets)
3. Hold-down ring (4- or 6-latch design, according to model)

## 4.2.2 Models 1994 and After

See section 4.2.1 for filter pack assembly. The illustration below shows the proper assembly of the filter pack.

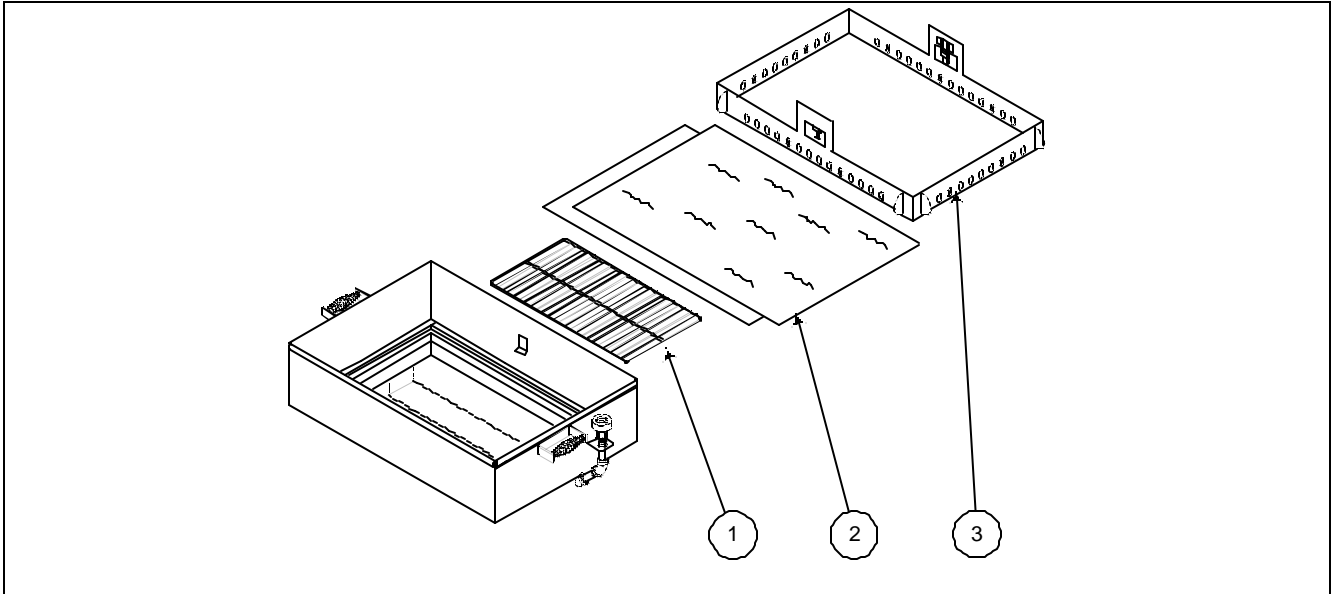

1. Paper support grid
2. Filter paper (2 sheets)
3. Hold-down ring (2-latch design)

## 4.3 Normal Operation

### 4.3.1 Models Prior to 1994

Micro-Flo Built-In filters come equipped with an individual return valve at each fryer vessel, or "push-pull" controls in the filter cabinet. The "push-pull" version oil-return valves are located inside of the filter cabinet. Manual-open valves are replaced with a push-pull linkage actuated valve.



Micro-Flo BI-Series with "Push-Pull" variation.

### 4.3.1 Models Prior to 1994 (cont.)

If filter is equipped to filter solid shortening, the "On-Off" switch will be a three-position switch labeled "Pump/Off/Heat". The "Pump" position is used to operate the filter. The "Heat" position is used to melt residual shortening from previous filter operations. Do not attempt to melt a block of solid shortening with the filter heater. Damage to the heating elements will occur.



#### **DANGER EXTREME BURN HAZARDS**

**The temperature of oil to be filtered should be approximately 350°F (175°C). When using flexible return hoses, hold the outlet nozzle securely in the frying vessel or filter pan at all times before operating power switches or valves. Failure to do this can result in severe burns.**

**Always wear oil-resistant, insulated gloves when working with hot oil!**

**Do not leave a filter machine unattended during operation. The action of the oil moving through the lines could cause a flexible return hose to shake loose and spray hot oil.**

#### 4.3.1.1 Filter Pan Setup

- A. First, place the support grid in the bottom of filter pan.
- B. Put two filter paper sheets on top of the support grid. Ensure the paper covers the whole filter pan bottom.
- C. Position the hold-down ring on top of the filter papers and latch the hold-down ring and filter papers securely against the filter pan bottom, forming a tight seal.
- D. Sprinkle 16 ounces of filter powder on the top filter sheet. Distribute the powder over the filter paper as evenly as possible. If filtering a second frypot immediately after the first, add only 8 ounces of filter powder for the second filtering.



#### **CAUTION**

**The crumb tray (if applicable) in built-in filter systems must be emptied into a fireproof container at the end of frying operations each day. Some food particles can spontaneously combust if left soaking in certain shortening material.**

- E. Place the crumb screen (if used) in the filter pan. Ensure the crumb screen is clean, prior to placement. Allow the crumb screen to rest on the top edges of the hold-down ring.
- F. Slide filter pan back inside cabinet and close door.

#### 4.3.1.2 Filter Operation

- A. Turn fryer "OFF".
- B. Filter one fryer at a time.
- C. Remove fry-baskets, crumb screen and/or drop-in grid from fryer.
- D. Stir the oil below the heat transfer tubes or electric elements with an "L" shaped Teflon brush (included with accessory pack) to loosen sediment.
- E. Open the drain valve at the fryer and continue to stir and brush down the sides of the vessel and tubes or electric elements.

- F. Push-Pull Variation: All oil-return valves are located inside the filter cabinet. Open the filter cabinet door. Pull the "Yellow" oil return valve handle corresponding to the fry vessel being filtered.

Standard Variation: Individual oil-return valves are located within each fryer cabinet. Open the fryer cabinet door at the fry vessel being filtered and open the oil return valve.

- G. Close the hose connect valve (or pull the red handle) at the filter.
- H. Turn the filter motor switch to "ON". Oil/shortening will be circulated through the filter.
- I. After filtering is complete, close the drain valve.
- J. Replace drop-in grid in fryer.
- K. Once the drop-in grid is covered with filtered oil/shortening, turn on the fryer power switch and push the reset switch (if applicable).



Push-pull variation valve control handles. Yellow handles operate oil return valves, and the red handle operates the hose connect valve.

#### 4.3.1.2 Filter Operation (cont.)

- L. Allow the filter to pump bubbles into the fryer for 15-20 seconds to ensure evacuation of all oil/shortening from the filter pan and return lines.
- M. Turn the filter switch to "OFF".
- N. Close the oil return valve (or push yellow handle) to the fryer being filtered.

**NOTE:** The filtering cycle for one fryer is complete. To filter additional fryers, repeat the above steps, starting with item "A". Complete the process with the following final step.

 **CAUTION**

**When the filter pump is "ON", NEVER open the hose connect valve without the optional flexible hose connected. Always ensure that the optional flexible hose is properly connected and the hose wand is firmly held in the filter pan or fry vessel prior to opening the hose connect valve. Failure to do this increases the chance of burn injury from spraying hot oil/shortening.**

- O. Open the hose connect valve (or push red handle) at the filter and close the filter cabinet door.

**NOTE**

With the hose connect valve "open", any oil left in the return lines will drain into the filter pan. With the return valve "closed", no oil will back-flush from the frying vessel, into the lines. When not filtering, leave the hose connect valve "open", and the oil-return valve "closed".

#### 4.3.1.3 Changing Filter Paper

The top piece of filter paper should be discarded when it becomes dark or scuffed in appearance. Follow the procedure below and refer to the illustration on page 4-1.

- A. Prior to changing the paper, use the optional flexible hose with about one-inch of oil in the filter pan or oil drawn from the fryer to flush all debris from the filter pan sides onto the paper.
- B. Return all oil to the fryer.
- C. Open the locking latches of the hold-down ring (see Item #3, page 4-1) and lift the ring out of the filter tank.
- D. Roll both ends of the used (top) sheet of paper in to the center, ensuring no sediment falls out. Discard top filter paper.
- E. Remove the second sheet of paper and set aside for later use.

#### 4.3.1.3 Changing Filter Paper (cont.)

- F. Remove and check the grid for cleanliness and clean if necessary.
- G. Inspect the filter pan for cleanliness and clean if necessary; also inspect the oil-pickup tube at the rear of the pan for obstructions or solidified shortening.
- H. Replace the bottom grid, place a new sheet of filter paper on the grid, and place the old bottom sheet on top of the new piece. Use only filter paper approved for the filtration system. Failure to do so will increase the likelihood of system malfunction.
- I. Replace the hold-down ring.

#### 4.3.2 Models 1994 and After

Beginning in 1994, Micro-Flo Built-In filters were redesigned with the following changes:

- An orange-handled valve with hose disconnect are located within the filter cabinet. An optional hose is available for washing out the fry vessel and filter pan during the filtering process.
- A user-friendly hold-down ring with two spring catches replaces the four- or six-latch hold-down ring.
- Pump and motor are relocated for easy serviceability.



Micro-Flo BI-Series new design.

- The oil/shortening vacuum line is outfitted with swivels, making it user-friendly and longer lasting.
- Lever-operated drain and oil-return valves are located within each fryer cabinet. An optional lever-operated drain-flush valve (if equipped) is located in the fryer cabinet furthest from the filter.

##### 4.3.2.1 Filter Paper Configuration

1. Disconnect the oil suction line from the filter pan and pull the pan out from the filter cabinet.
2. Ensure paper support grid is in position. Place two pieces of filter paper over the support grid, completely covering the bottom of the pan. Replace the hold-down ring and lock into place with spring catches on each side of the hold-down ring.

#### 4.3.2.1 Filter Paper Configuration (cont.)

3. Sprinkle 16 ounces of filter powder evenly over the filter paper. Return the filter pan to filter cabinet, ensuring that the drainpipe outlets are directly over filter pan. If filtering a second frypot immediately after the first, add only 8 ounces of filter powder for the second filtering.
4. Reconnect the oil-suction line to filter pan and snap into place. Ensure the quick-disconnect fitting is properly connected by pulling up on the male assembly while snapping into place.
5. Close cabinet door. Filter is ready for operation.

#### 4.3.2.2 Filter Operation

1. Ensure that the power switch or operating thermostat dial is in the "OFF" position.
2. Remove fry-baskets, crumb screens and/or support grids along with any large debris on the screens. Stir the oil under the heat transfer tubes or elements with the L-shaped teflon brush.

NOTE: Inspect the high-limit and thermostat bulbs to ensure they are properly mounted. Ensure that all mounting hardware is intact and properly tightened.



Cleaning fry-vessel tubes and bottom with "L-shaped" brush.

3. Open the fryer drain of the fryer to be filtered by pulling the "Red" drain valve handle under the fryer vessel. Continue stirring the oil as it drains from the fry vessel. With the L-shaped brush, scrub the undersides and between the tubes (gas fryers), or under and around the heating elements (electric). Brush the vessel sides and tops of tubes to remove debris. Use care not to damage sensing bulbs or heating elements while removing debris. If the drain becomes blocked by debris, clear the blockage with the cleanout rod.
4. Pull the "Yellow" handle located to the left of the drain valve to open the oil return valve.

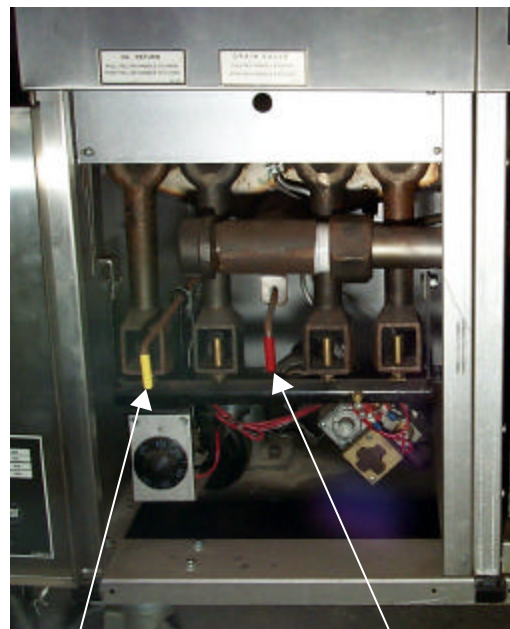

"Yellow" oil-return handle.

"Red" drain-valve handle.

#### 4.3.2.2 Filter Operation (cont.)

5. Ensure the "Orange" handle in the filter cabinet is closed and turn the filter power switch "ON".



Turn "Orange" handle to the right (handle end "UP") to close hose connect valve.

Note: The filter circuit is protected by a 7-amp breaker located on the control panel of the filter cabinet. If the circuit breaker trips, turn the filter "OFF", reset breaker and continue filtering. If the breaker continues to trip, ensure the correct oil-return valve for the fryer being filtered is "ON", and that there are no obstructions in the return lines.

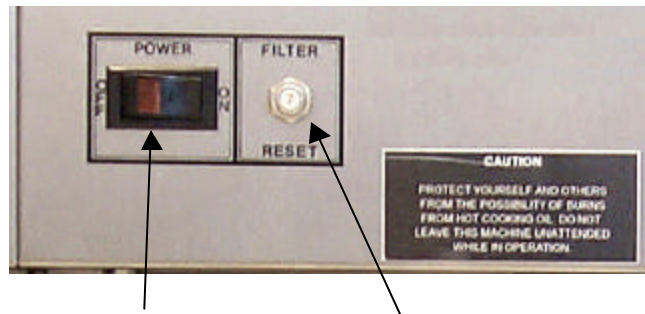

Filter power switch and circuit protection breaker.

6. If the filter system is equipped with the drain-flush option, close the flush valve by pulling the "Blue" handle located in the fryer cabinet farthest from the filter cabinet.
7. Oil should circulate through the filter and back to the fryer vessel. Continue to use the L-shaped brush to wash debris from the sides and bottom of the fryer.
8. Close drain valve when fryer is clean by pushing the "Red" handle. Continue pumping filtered oil back into the fryer.



Pull "Blue" handle to close the drain-flush valve (if applicable).

#### 4.3.2.2 Filter Operation (cont.)

**Note:** Drain-Flush Line Only- If fryer being filtered is used for frying heavily breaded products, or is the last fryer in the battery, use the drain flush to flush excess sediment from the drainpipe into the filter pan.

**⚠ CAUTION**  
**When the drain flush is used to keep drain line unclogged, ALL RED DRAIN VALVES MUST BE CLOSED.**

9. Open the drain flush valve by pushing the "Blue" handle located in the fryer cabinet furthest from the filter cabinet. Close the "Yellow" oil-return valve to the fryer being filtered. All valve handles should now be pushed in.

10. When the drain line is flushed, open the "Yellow" oil return valve to the fryer being filtered. Pull the "Blue" handle to close the drain flush line. Filtered oil/shortening will begin to fill the fry vessel.



Fry vessel refilling with filtered oil/shortening.

**⚠ CAUTION**  
Wear protective gloves and use an appropriate tool when replacing drop-in grid/crumb screen in fry vessel. Filtered oil is hot and can cause burn injury.

11. Turn the fryer power-switch "ON" when filtered oil/shortening covers the heat transfer tubes or heating elements. Replace the crumb screen or drop-in grid.



Replace drop-in grid/crumb screen as oil level rises. Use an appropriate tool (fryer cleanout tool, etc.) to place the screen in hot, filtered oil/shortening.

#### 4.3.2.2 Filter Operation (cont.)

12. Allow the filter to pump bubbles into the fryer for 15-20 seconds to ensure evacuation of all oil/shortening from the filter pan and return lines.
13. Close the "Yellow" oil-return valve and immediately turn the filter pump "OFF". Ensure all oil return valves are completely closed so as to prevent oil/shortening from siphoning out of the fry vessels. Close all doors. Fryers are ready for operation.



Bubbling oil indicates air is being pumped through the oil return lines.

#### 4.3.1.3 Changing Filter Paper

The top piece of filter paper should be discarded when it becomes dark or scuffed in appearance. Follow the procedure below and refer to the illustration on page 4-2.

1. Prior to changing the paper, use the optional flexible hose with about 1-inch of oil in the filter pan or oil drawn from the fryer to flush all debris from the filter pan sides onto the paper.
2. Return all oil to the fryer.
3. Open the locking latches of the hold-down ring (see Item #3, page 4-2) and lift the ring out of the filter tank.
4. Roll both ends of the used (top) sheet of paper in to the center, ensuring no sediment falls out. Discard top filter paper.
5. Remove the second sheet of paper and set aside for later use.
6. Remove and check the grid for cleanliness and clean if necessary.
7. Inspect the filter pan for cleanliness and clean if necessary; also inspect the oil-pickup tube at the rear of the pan for obstructions or solidified shortening.
8. Replace the bottom grid, place a new sheet of filter paper on the grid, and place the old bottom sheet on top of the new piece. Use only filter paper approved for the filtration system. Failure to do so will increase the likelihood of system malfunction.
9. Replace the hold-down ring.

## 4.5 Operating Problems

Operating problems account for over 90 percent of filtration system malfunctions. If solid shortening is being used, and the filter is operated improperly, shortening solidification will occur in the lines as the shortening cools, increasing the chance for clogged lines.

Micro-Flo Built-In filtration systems are equipped with an overload circuit breaker to help prevent filter motor damage in case of overload. Obstructions in the oil return lines can cause motor overheating, which eventually results in motor overload. If the oil return valve is open and filtered oil is not flowing into the fryer, then shortening has solidified in the lines.

Clogs or plugs can occur anywhere in the system. Locate the blockage by examining each part of the filter system — the filter pan assembly, hoses and lines in the filter, and return lines or hoses to the fryer.



**DANGER**

**Never use a propane torch to melt solidified shortening in any part of the fryer/filtration system.**

### 4.5.1 Plugged Paper

Plugged paper: Improper use of filter powder will cause a slow oil flow return rate. The top filter paper should be scraped (if not discarded) after filtering oil used for heavily breaded products. The first indication of paper plugging is a surging, jerking movement of the hose. To correct, check the instructions for the correct use of powders, and scrape the filter paper more frequently.

### 4.5.2 Plugged Pan Bottom Intake

Five oil-intake ports are located under the filter paper and wire grid in the filter pan. When filter paper is changed, debris can fall into the bottom cavity where it collects around the intake ports. The ports are located on the underside of the projecting pipe and cannot be seen. Remove the filter paper and grid periodically to clean these ports.

### 4.5.3 Plugged Filter

- A. If the filtration system is equipped with a pan heater, turn the heater on for approximately 20 minutes. Residual shortening in the bottom of the filter pan should melt during this time. Insert the flexible hose (if so equipped) into the filter pan holster and turn the pump motor switch to the "Out" or "On" position. With the lever-operated valve "Open", visually confirm that oil circulates in the filter. If it does not, the filter pan, filter pump or any of the hoses and/or lines could be clogged.
- B. Disconnect the oil line from the filter pan to the pump. Put your finger over the inlet connection of the pump and turn the filter motor switch to "Out" or "On". If suction is felt, then the pump is clear and the plug is in the bottom of the filter, or in the filter line leading to the pump.

### 4.5.3 Plugged Filter (cont.)

 **WARNING**

**Never blow into filter return lines while the lines are connected to locate a plug. Never hold your hand over the outlet end of a line. A plug could unexpectedly release and spray hot oil, causing severe burns.**

**When checking the filter pump for blockage, turn the power switch to the "Out" or "On" position.**

- C. Disconnect the tubing from the bottom of the filter pan to the pump return line and try to blow through it. If air will not flow through, the return line is plugged. Soak the line in hot water until air can be blown through it.
- D. When the pump return line is clear, reconnect it to the pan and turn the motor switch to "Out" (or "On"). If oil still does not flow, inspect the bottom of the filter pan for blockages. Disassemble the filter pan and thoroughly wash the pan in hot, soapy water. Dry thoroughly before reassembling.

### 4.5.4 Return Lines

- A. If your system is equipped with a flexible return hose, turn the motor "Off" and disconnect the hose. Attempt to blow through the hose from the inlet end. If no air will pass through the hose, then suspect a clog. Soak the hose in hot water to melt the plug.

**Note:** When soaking a line in hot water, keep both open ends out of the water. If water gets into the hose, ensure that all traces are removed before filtering hot oil/shortening. Failure to do so will result in hot oil spattering, increasing the potential for burn injury.

Reconnect the flexible hose and insert the outlet nozzle into the filter pan holster. Turn the pump switch to "Out" (or "On"). If oil does not flow to the fryer being filtered, then inspect the return lines between the filter pump and the fry vessel.

- B. If the filter system is configured with one built-in return line, with exits to individual fryers, turn the filter pump "Off", and close all fryer return valves. Open the return valve closest to the filter and turn the pump "On". If oil flows, then inspect the next fryer. Continue the process until the blockage is discovered. When the blockage is located, disassemble that part of the return line and clean thoroughly. Reassemble the return line and check for blockages.
- C. The "push-pull" filter version utilizes individual return lines from the filter to each fryer. Check each line for oil flow after inspecting other parts of the filter system. Once the plugged line is discovered, completely disassemble and clean the line.

#### **4.5.4 Return Lines (cont.)**

To prevent plugged lines when using solid shortening, adhere to the following:

- ☞ If the filter is equipped with a pan heater, use it each time a fryer is filtered.
- ☞ Allow the pump to run for 15-20 seconds after air starts to flow through the lines (or flexible hose), before shutting off the filter. Clearing residual shortening/oil from the return lines reduces the likelihood of clogged lines.
- ☞ When the filtering cycle is complete, disconnect the flexible line and hang it up to drain.

# MICRO-FLO BUILT-IN SERIES FILTRATION SYSTEMS

## CHAPTER 5: CLEANING & MAINTENANCE

---

### 5.1 Each Filter Use

Every time the Micro-Flo filter is used:

- Wash down the insides of the filter pan with hot oil.
- Change the top filter paper sheet after each filter session or at the end of the day. Scrape sediment from the top sheet after each frypot is filtered within a filter session.
- Wipe up any oil which may have splashed or spilled.
- Wipe all exterior surfaces of the filter unit.

**NOTE:** Always scrape sediment and debris from the paper when the system is warm, to prolong the life of the paper.

#### CAUTION

**Do not run water or boil-out solution through the filtration system. Doing so will cause irreparable damage to the pump, and the warranty will be voided.**

### 5.2 Daily-Close of Business

At the close of a working day, the last order of business should be to filter the oil in all fryers. When the last fryer is finished, follow these steps:

1. Ensure the flexible hose and pump lines are clear by running the filter pump for an additional 15–20 seconds after air bubbles start coming from the oil return line. After filtering, hang the flexible hose up to drain.
2. Remove the crumb tray and empty contents into a fireproof container. Remove the hold-down ring assembly, then remove the filter paper and filter support screen.
3. Discard the top filter paper sheet and retain bottom filter paper sheet for re-use.
4. Wash all filter components with hot soapy water and rinse.
5. Dry all filter parts and filter pan thoroughly before reassembling.
6. Check all fittings at the rear of the filter unit; ensure that all fittings are properly tightened.

#### CAUTION

**The crumb tray (if applicable) in built-in filter systems must be emptied into a fireproof container at the end of frying operations each day. Some food particles can spontaneously combust if left soaking in certain shortening material.**

## 5.3 Weekly

Follow the same procedure as for “Daily”, with these additional steps:

- Wash the filter pan with hot, soapy water and a brush. Dry and reassemble with new filter paper.
- Clean thoroughly under, around, and behind the fryers and filtering area.
- Do not operate motor/pump until all traces of water have been removed from the pan. Under no circumstances should water or boil-out solution be allowed to enter the pump housing.
- Check the connections of the inlet lines and tighten if lines become loose or start to leak oil.

# MICRO-FLO BUILT-IN SERIES FILTRATION SYSTEMS

## CHAPTER 6: TROUBLESHOOTING

---

### **6.1 Oil Does Not Re-circulate In Filter and/or Does Not Return To Fryer.**

- A. System may be plugged with solid shortening in pan sump or in pump. The pump operates without circulating oil. See Section 4.5.2 & 4.5.3.
- B. Check for loose connections in the suction line. Tighten all loose fittings.
- C. Shortening may have solidified in internal return lines; see section 4.5.4.

### **6.2 Rate Of Oil Return To Fryer Slows.**

- A. Filter paper is plugged due to too much sediment in fryer. Scrape top filter paper (or replace) after each filtering cycle and filter the oil more frequently.
- B. Paper may be plugged by improper use of filter powder. Replace top filter paper and apply the correct amount of filter powder, according to labeled directions.
- C. Sediment may be collected around suction pipe in filter bottom. Remove the paper support grid and clean out sediment, ensuring that all five inlet ports are free of sediment.

# MICRO-FLO BUILT-IN SERIES FILTRATION SYSTEMS

## CHAPTER 7: FACTORY SERVICE AND PARTS ORDERING

---

### 7.1 Factory Service

**FACTORY SERVICE:** Call the '800' number on the cover of this manual for the location of your nearest Factory Authorized Service Center (FASC) or contact the factory direct. Always give the model and serial numbers of your filter.

### 7.2 Parts Ordering

**PARTS ORDERING:** Customers may order parts directly from their local FASC. For this address and phone number, contact your FASC or call the factory. Factory address and phone numbers are on the back cover of this manual.

#### **IMPORTANT**

Dean, whose policy is one of constant improvement, reserves the right to amend specifications of any part or assembly and the materials and finishes comprising the Micro-Flo Filtration system and its accessory equipment without prior notice.



## 7.3 Parts List

### 7.3.1 MF90-BI Standard Variation (Prior to 1994)

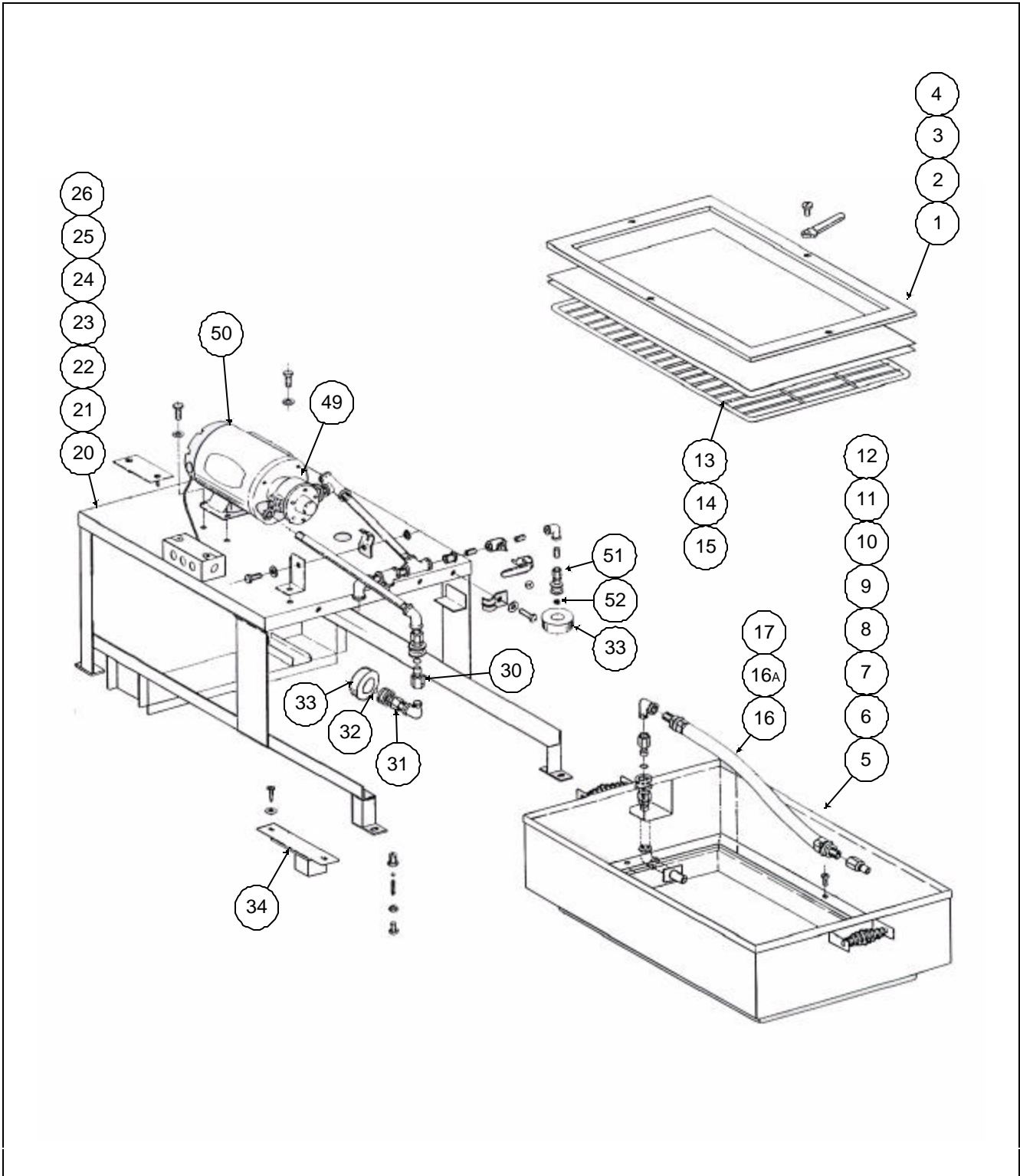

### 7.3.1 MF90-BI Standard Variation (Prior to 1994, cont.)

Item No	Part No	Description
1	55127	#12 Hold-Down Ring Assembly
2	55079	#14 Hold-Down Ring Assembly
3	55308	#18 & #20 Hold-Down Ring Assembly
4	55308	6-Latch Hold-Down Ring Assembly
5	55256	#12 Pan Assembly
6	55077	#14 Pan Assembly
7	18042	#18 Pan Assembly
8	44129	#18 Pan Assembly- Stationary/Portable Systems
9	44122	#18 Pan Assembly, Luther's System
10	44115	#18 Pan Assembly, Lee's System
11	20011	#20 Pan Assembly, Standard & Grandy's Systems
12	44242	#20 Pan Assembly, Stationary/Portable Systems
13	55369	#12 Grid & Channel Assembly
14	55122	#14 Grid & Channel Assembly
15	55121	Jumbo Grid & Channel Assembly
16	55452-167	Pump to Pan Hose, #12
16A	55452-167	Pump to Pan Hose, #14
17	55452-215A	Pump to Pan Hose, #18 & #20
*	55452-312	26" Hose Return, Stationary/Portable Only
*	44251	7" Re-circulating hose
20	55243-1	#12 Filter Frame, No Heater
*	55243-2	#12 Filter Frame, w/Heater
21	55007	#14 Filter Frame
22	18040-1	#18 Filter Frame, No Heater
*	18040-2	#18 Filter Frame, w/Heater
23	20015-1	#20 Filter Frame, No Heater
*	20015-2	#20 Filter Frame, w/Heater
24	44119	Filter Frame, Luther's System
25	44106	Filter Frame, Lee's System
26	44214	Filter Frame, Standard/Portable, #18 & #20
*	1541	On-Off Toggle Switch
*	1083	On-Off-Heater Toggle Switch
*	1385	In-Off-Out Toggle Switch (3PDT)
30	1644	Seal, Quick Disconnect, 1/2" - Male
31	55191	Seal, Quick Disconnect, 1/2", Female
*	55016	Seal, Quick Disconnect, 3/4", Female
32	1645-1	O-Ring, "Snap-Tite" Seal, 1/2"
33	1969	Snap Ring
*	1608	8" Heater strip
*	1086	21" Heater strip (Luther's System)
*	2036	Circuit breaker
*	1902	O-ring, (Lee's System)
* Not Illustrated		

### 7.3.1 MF90-BI Standard Variation (Prior to 1994, cont.)

<b>Item No</b>	<b>Part No</b>	<b>Description</b>
*	44126	Hose/nozzle ass'y, complete (Lee's System)
*	55452-677	Hose ass'y, 66-1/2" (Lee's System)
*	44107	Nozzle ass'y, (Lee's System)
*	44117	Holster support, R/H
*	44116	Holster support, L/H (Lee's System)
*	44-0250	Filter hose keeper (Lee's System)
*	44112	Filter basket, BI-18 (Lee's System)
*	44134	Filter basket, standard, BI-18 & 20
*	14229	Filter basket, BI-12
*	44378	Filter basket, BI-18 (Capt D's System)
49	1726-1	Filter Pump
50	1726-2	Pump Motor
51	1645	(Same as item 31)
52	1645-1	(Same as item 32)
* Not Illustrated		

### 7.3.2 MF90-BI Push-Pull Variation (Prior to 1994)

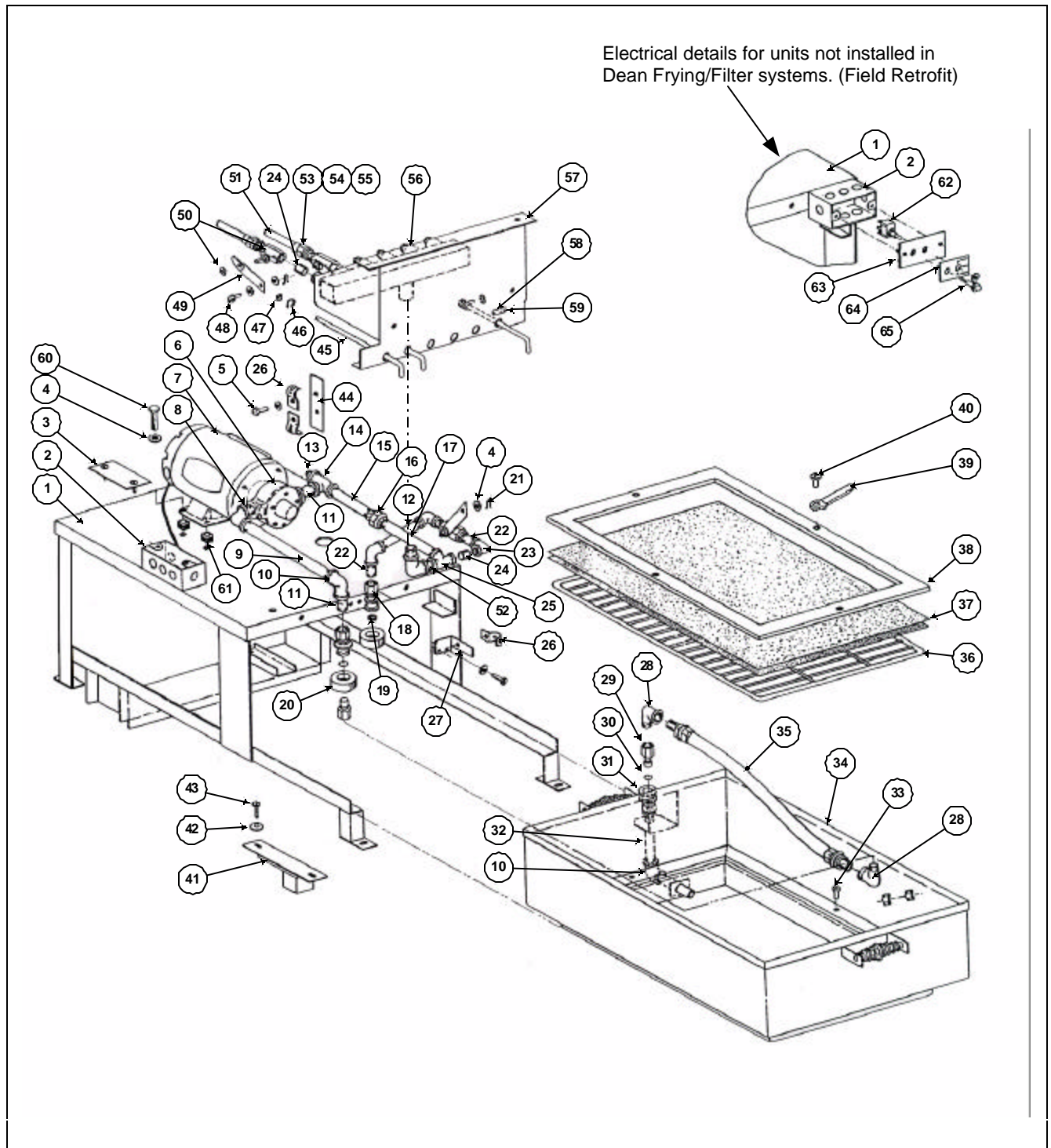

### 7.3.2 MF90-BI Push-Pull Variation (Prior to 1994, cont.)

Item No	Part No	Description
1	55243	Filter Frame Assembly
2	1085	Junction box
3	1090	Cover Plate, w/Screws
4	1008	Washer, Flat-1/4"
5	1004	Bolt, 1/4-20 x 1/2"
6	1726-1	Pump, 5 GPM
7	1726-2	Motor, Pump
8	1059	Nipple, 1/2" x 1-1/2"
9	44-0585	Nipple, 1/2" x 11-1/2"
10	11011	Elbow, 1/2" x 90°
11	1060	Nipple, 1/2" x 2"
12	1756	Nipple, 3/8" x 5"
13	1831	Plug, 1/2"
14	1058	Tee, 1/2"
15	1074	Nipple, 1/2" x 5"
16	1061	Union, 1/2", black
17	2067	Nipple, 1/2" x 5-1/2"
18	1015	Female connector, 3/8"
19	1350	Quick disconnect seal, 3/8"
20	55-0016	Quick disconnect collar
21	2123	Cotter pin, 3/32" x 3/4"
22	1798	Nipple, 3/8" x 2"
23	1043	Elbow, 3/8" x 90°
24	1014	Nipple, 3/8" x close
25	1765	Tee, 1/2" x 3/8" x 1/2"
26	1856	Pipe clamp, 1/2" (Jiffy H-40)
27	44-0662	Pipe holding bracket
28	1687	Street elbow, 1/2"
29	1644	Male connector, 1/2"
30	1645-1	Quick disconnect seal, 1/2"
31	55-0253	Female connector, 1/2"
32	1062	Nipple, 1/2" x 7-1/4"
33	1033	Screw, 1/4-8 x 1/2"
34	18042	Pan Assembly, #1818 & #1824
*	20011	Pan Assembly, #2020
*	55244	Pan Assembly, #1212
35	44361	Pump to pan hose Assembly, #2020 & #1824
*	55211	Pump to pan hose Assembly, #1212
36	55121	Grid Assembly, #1818, #2020, #1824
*	55156	Grid Assembly, #1212
* Not Illustrated		

### 7.3.2 MF90-BI Push-Pull Variation (Prior to 1994 cont.)

Item No	Part No	Description
37	1054	Filter paper, jumbo, 16-3/8" x 24-1/2"
*	1334	Filter paper, #12, 11" x 22-5/8"
38	55033	Hold-down ring Assembly, #1818, #2020, #1824
*	55127	Hold-down ring Assembly, #1212
39	55-0011	Hold-down lever
40	55-0004	Shoulder bolt
41	1608	Strip heater, 8"
42	21-0120	Washer
43	1032	Screw, 10-32 x 1/2"
44	44-0583	Pipe holding bracket
45	44-0490	Pull handle
46	1877	Split lock washer, 5/16"
47	1225	Hex nut, 5/16"
48	44381	Clevis pin Assembly
49	44305	3/8" ball valve handle
50	1100	Ball valve, 3/8"
51	1034	Steel tubing, 1/2"
52	1010	Nipple, 1/2" x close
53	1036	Flare nut, 1/2"-37
54	1985	Flare fitting, 1/2" x 3/8"
55	1037	Tubing sleeve, 1/2"
56	1674	Pipe plug, 3/8"
57	44323	Oil manifold holder Assembly
58	44-0377	Instruction tag
59	1047	Pop rivet, 3/32"
60	1769	Bolt, 1/4-20 x 1-1/2"
61	44-0516	Vibration damper
62	1083	Switch
63	44-0440	Mounting plate
64	1081	Label, switch position
65	1082	Indicator light
* Not Illustrated		

### 7.3.3 MF90-BI Standard Variation (Units Built 1994 and After, cont.)

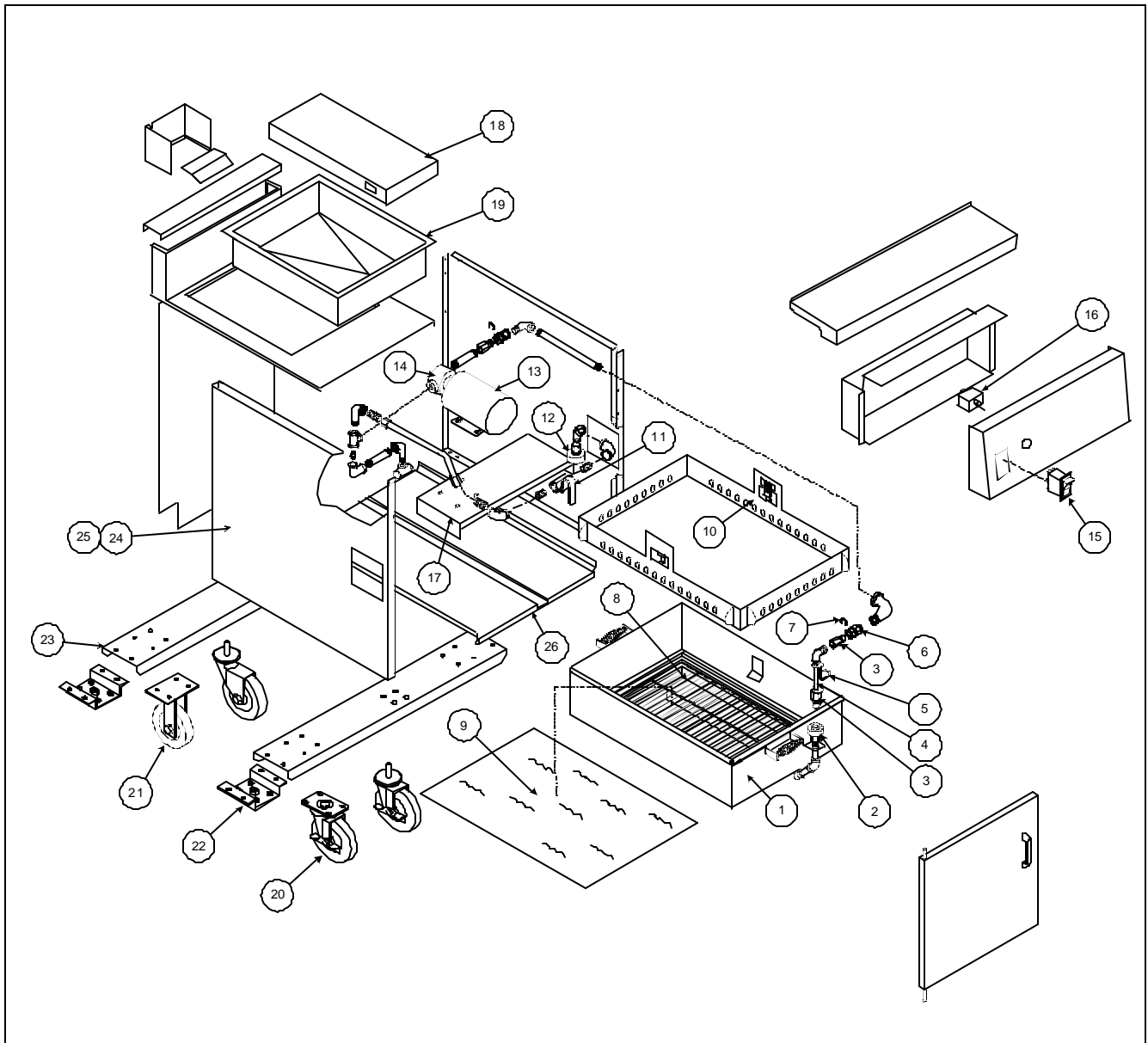

### 7.3.3 MF90-BI Standard Variation (Units Built 1994 and After)

Item No	Part No	Description
1	55396-1	Filter Pan Assembly, BI-12A- No Heater
2	55191	Collar, Quick-Disconnect Assembly-Female
3	1644	Quick Disconnect- Male
4	1074	Nipple, ½ x 5", Blk-NPT
5	55379	Handle Assembly, Disconnect
6	1645	Quick Disconnect- Female
7	1969	Snap Ring
8	55370	Screen Assembly-Pan
9	1334	Filter Paper- 11 x 22-5/8"
10	55372	Hold-down Ring Assembly
11	1100A	Ball Valve, 3/8"
12	55016	Collar-3/8"- Quick Disconnect
13	1892-2	Motor, 1/3HP- 230/120V/50/60 Hz
*	1726-2	Motor, 1/3 HP 120V/60 Hz
14	1726-1	Pump, 5 GPM
*	1742-2	Pump, 8 GPM
*	1848	O-ring Seal, Pump Head
*	1847	Seal, Drive Shaft
15	2025	Rocker Switch, Carling
16	2036	Circuit Breaker, 7 Amp
17	24-0471	Mounting Plate, Pump Motor
18	2501	Merco Heat Lamp- 120V
*	2556	Merco Heat Lamp- 240V
*	807-1575	Replacement Lamp- 120V
*	2556-1	Replacement Lamp- 240V
19	44569	Holding Pan
20	1942	Caster- 5" with Brake (Single Stud)
*	<a href="#">810-0357</a>	Caster, Swivel-5" with Brake (4-Hole)
21	1943	Caster- 5" w/o Brake (Single Stud)
*	<a href="#">810-0356</a>	Caster, Swivel-5" w/o Brake (4-Hole)
*	<a href="#">810-0378</a>	Caster, 5" rigid (4-hole)
22	12085	Leg Support Assembly
23	60-0007-1	Base Channel, Single Unit
*	60-0007-2	Base Channel, 2 Unit
*	60-0007-3	Base Channel, 3 Unit
*	60-0007-4	Base Channel, 4 Unit
24	60-0022-1	Inside Panel- LH
*	60-0022-2	Inside Panel- RH
25	60-0021-1	Side Panel- LH
*	60-0021-2	Side Panel- RH
26	50-0015	Pan Rail
*Not Illustrated		

## 7.4 Wiring Diagrams

### 7.4.1 MF90-BI With Heater

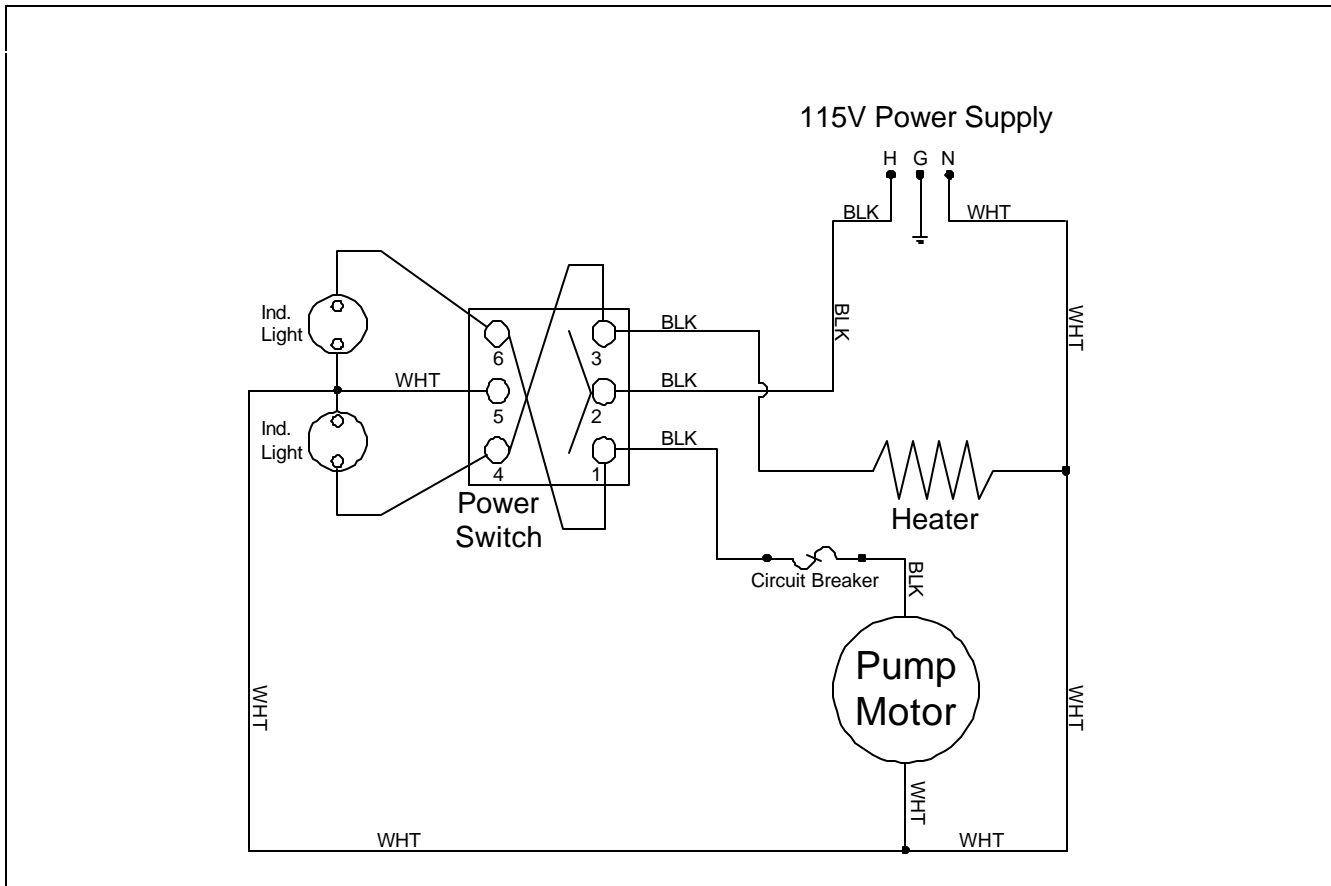

### 7.4.2 MF90-BI Without Heater

