

**SERVICE AND PARTS
FRYMASTER BIGL30 SERIES MANUAL LOV™
GAS FRYER**



This equipment chapter is to be installed in the Fryer Section of the *Equipment Manual*.

FOR YOUR SAFETY
Do Not Store or use gasoline or other flammable vapors and liquids in the vicinity of this or any other appliance.



MANUFACTURED
BY
Frymaster[®]
8700 Line Avenue
SHREVEPORT, LOUISIANA 71106
PHONE: 1-318-865-1711
TOLL FREE: 1-800-551-8633
1-800-24 FRYER



Frymaster L.L.C., 8700 Line Avenue, Shreveport, LA 71106
PHONE 318-865-1711

PRINTED IN THE UNITED STATES

SERVICE HOTLINE 1-800-24-FRYER

10/2023

www.frymaster.com

Email: service@frymaster.com



8 1 9 6 9 6 8

NOTICE

IF, DURING THE WARRANTY PERIOD, THE CUSTOMER USES A PART FOR THIS FRYMASTER DEAN EQUIPMENT OTHER THAN AN UNMODIFIED NEW OR RECYCLED PART PURCHASED DIRECTLY FROM FRYMASTER DEAN OR ANY OF ITS FACTORY AUTHORIZED SERVICERS, AND/OR THE PART BEING USED IS MODIFIED FROM ITS ORIGINAL CONFIGURATION, THIS WARRANTY WILL BE VOID. FURTHER, FRYMASTER DEAN AND ITS AFFILIATES WILL NOT BE LIABLE FOR ANY CLAIMS, DAMAGES OR EXPENSES INCURRED BY THE CUSTOMER WHICH ARISE DIRECTLY OR INDIRECTLY, IN WHOLE OR IN PART, DUE TO THE INSTALLATION OF ANY MODIFIED PART AND/OR PART RECEIVED FROM AN UNAUTHORIZED SERVICE CENTER.

 **DANGER**

Copper wire suitable for at least 167°F (75°C) must be used for power connections.

 **DANGER**

The electrical power supply for this appliance must be the same as indicated on the rating and serial number plate located on the inside of the fryer door.

 **DANGER**

This appliance must be connected to the voltage and phase as specified on the rating and serial number plate located on the inside of the fryer door.

 **DANGER**

All wiring connections for this appliance must be made in accordance with the wiring diagrams furnished with the equipment. Wiring diagrams are located on the inside of the fryer door.

 **DANGER**

Do not store or use gasoline or other flammable vapors and liquids in the vicinity of this or any other appliance.

 **WARNING**

Do not attach accessories to this fryer unless fryer is secured from tipping. Personal injury may result.

 **WARNING**

Frymaster fryers equipped with legs are for permanent installations. Fryers fitted with legs must be lifted during movement to avoid damage and possible bodily injury. For a moveable or portable installation, Frymaster optional equipment casters must be used. Questions? Call 1-800-551-8633 or email at service@frymaster.com.

 **WARNING**

Do not use water jets to clean this equipment.

 **WARNING**

This equipment is intended for indoor use only. Do not install or operate this equipment in outdoor areas.

 DANGER

Adequate means must be provided to limit the movement of this appliance without depending on or transmitting stress to the electrical conduit. A restraint kit is provided with the fryer. If the restraint kit is missing contact your local KES.

 DANGER

Prior to movement, testing, maintenance and any repair on your Frymaster fryer, disconnect all electrical power from the fryer.

BIGL30 SERIES GAS FRYERS

TABLE OF CONTENTS

WARRANTY	i
CHAPTER 1: Service Procedures	
1.1 Functional Description.....	1-1
1.2 The Electronic Ignition System.....	1-1
1.3 Interface Board.....	1-2
1.4 Thermostats	1-4
1.5 Accessing Fryers for Servicing.....	1-4
1.6 Cleaning the Gas Valve Vent Tube.....	1-5
1.7 Checking the Burner Manifold Gas Pressure.....	1-5
1.8 Measuring Flame Current	1-6
1.9 Replacing Fryer Components	1-7
1.9.1 Replacing the Controller or the Controller Wiring Harness.....	1-7
1.9.2 Replacing the Temperature Probe or High-Limit Thermostat.....	1-7
1.9.3 Replacing the Interface Board.....	1-8
1.9.4 Replacing an Ignition Module	1-8
1.9.5 Replacing an Igniter Assembly	1-8
1.9.6 Replacing or Cleaning a Combustion Air Blower.....	1-9
1.9.7 Adjusting the Air/Gas Mixture	1-10
1.9.8 Replacing a Gas Valve.....	1-11
1.9.9 Replacing a Burner Assembly	1-12
1.9.10 Replacing the Filter Motor, Filter Pump, or Filter Pump Solenoid Valve	1-13
1.9.11 Replacing the Frypot	1-13
1.9.12 Replacing Frypot Insulation and/or Upper Burner Rails	1-14
1.10 Troubleshooting and Problem Isolation.....	1-17
1.10.1 Ignition Failure.....	1-18
1.10.2 Improper Burner Function	1-18
1.10.3 Improper Temperature Control.....	1-20
1.10.4 Computer Malfunctions	1-20
1.10.5 Filtration Malfunctions	1-20
1.10.6 Leakage.....	1-21
1.11 Troubleshooting Guides	1-21
1.11.1 Troubleshooting the 24 VAC Circuit	1-22
1.11.2 Troubleshooting the Gas Valve	1-24
1.11.3 Troubleshooting the Temperature Probe.....	1-25
1.11.4 Replacing the Transformer, Reset Switch or Filter Relay.....	1-25
1.12 Probe Resistance Chart	1-26
1.14 M3000 Computer Service Procedures	1-27
1.14.1 M3000 Computer Troubleshooting.....	1-27
1.14.2 M3000 Useful Codes and Passwords	1-30

BIGL30 SERIES GAS FRYERS

TABLE OF CONTENTS cont.

1.14.3	Service Required Errors	1-30
1.14.4	Error Log Codes	1-31
1.14.5	M3000 Menu Summary Tree.....	1-32
1.14.6	M3000 Controller Pin Positions and Harnesses	1-33
1.15	Loading and Updating Software Procedures	1-34
1.16	Principal Wiring Connections	1-35
1.17	Wiring Diagrams.....	1-36
1.17.1	BIGL230/430 Wiring	1-36
1.17.1.2	BIGL230/430 CE Fenwal Module GIVEC Wiring.....	1-37
1.17.2	BIGL330 Wiring	1-38
1.17.2.1	BIGL330 CE Fenwal Module GIVEC Wiring.....	1-39
1.17.3	BIGL430 Extra Transformer Box Wiring	1-40
1.18	Simplified Wiring Diagrams	1-41
1.18.1	BIGL30 Series Full Vat Single Spark Module.....	1-41
1.18.2	BIGL30 Series Dual Vat Single Spark Module	1-42
1.18.3	BIGL30 Series Data Network Flowchart.....	1-43
1.18.3	BIGL30 Series Data Network Flowchart without LON	1-44

CHAPTER 2: Parts List

2.1	Accessories.....	2-1
2.2	Doors, Sides, Flue Caps, Top Caps and Casters	2-1
2.3	Drain System Components	2-3
2.3.1	Drain Valves and Associated Parts	2-3
2.3.2	Drain Tube Sections and Associated Parts	2-4
2.4	Electronics and Electrical Components.....	2-5
2.4.1	Computers and Associated Components.....	2-5
2.4.2	Control Box.....	2-6
2.4.3	Transformer Box.....	2-8
2.5	Wiring.....	2-9
2.5.1	Main Wiring Harnesses	2-9
2.5.2	M3000 Communication Wiring Harnesses	2-10
2.6	Frypots and Associated Components	2-11
2.6.1	Full-Vat Frypot Components	2-11
2.6.2	Dual-Vat Frypot Components	2-13
2.6.3	Frypot Probes and Thermostats	2-15
2.7	Gas Valves, Supply and Combustion System Components	2-16
2.8	Filtration System Components	2-18
2.9	Filter Pump, Motor and Associated Components.....	2-19
2.10	Frypot Assemblies and Associated Parts.....	2-20
2.11	Oil Return System Components.....	2-21
2.12	Wiring Connectors, Pin Terminals, and Tools	2-22
2.13	Fasteners	2-23

MANUAL LOV™ GAS WARRANTY STATEMENT

Frymaster, L.L.C. makes the following limited warranties to the original purchaser only for this equipment and replacement parts:

A. WARRANTY PROVISIONS - FRYERS

1. Frymaster L.L.C. warrants all components against defects in material and workmanship for a period of two years.
2. All parts, with the exception of the frypot, O-rings and fuses, are warranted for two years after installation date of fryer.
3. If any parts, except fuses and filter O-rings, become defective during the first two years after installation date, Frymaster will also pay straight-time labor costs up to two hours to replace the part, plus up to 100 miles/160 km of travel (50 miles/80 km each way).

B. WARRANTY PROVISIONS - FRYPOTS

1. Frymaster warrants the frypot assembly for fifteen (15) years. First ten (10) years parts and labor. Years eleven (11) through fifteen (15) frypot only. Components attached to the frypot, such as the high-limit, probe, gaskets, seals, ignitors and related fasteners, are also covered by the fifteen year warranty if replacement is necessitated by the frypot replacement. Components that are not part of the frypot assembly, such as the blower, gas valve, micro switches, doors and cabinetry are not covered by the frypot warranty. Leaks due to abuse or from threaded fittings such as probes, sensors, high-limits, drain valves or return piping are not included. If the frypot is found to be defective, Frymaster will replace the frypot, allowing up to the maximum time per the Frymaster time allowance chart hours of straight-time labor plus up to 100 miles/160 km of travel (50 miles/80 km each way) to change the frypot.
2. This warranty is limited to fryers operating on natural or propane (LP) gas. Fryers that operate on manufactured gas (also known as town gas or high-hydrogen gas) have a lifetime frypot warranty, parts only.

C. WARRANTY PROVISIONS – COMBUSTION CHAMBERS

1. Frymaster L.L.C. warrants the combustion chambers against defective material or workmanship for a period of ten years from the original installation date, parts and labor.
2. The combustion chamber consists of the infrared burners and the structural components to mount the burners. This warranty does not cover ancillary components, including the igniter, blower, high-limit thermostat, and temperature probe.
3. This warranty is limited to fryers operating on natural or propane (LP) gas.

E. PARTS RETURN

All defective in-warranty parts must be returned to a Frymaster Authorized Factory Servicer within 60 days for credit. After 60 days, no credit will be allowed.

F. WARRANTY EXCLUSIONS

This warranty does not cover equipment that has been damaged due to misuse, abuse, alteration, or accident such as:

- improper or unauthorized repair (including any frypot which is welded in the field);
- failure to follow proper installation instructions and/or scheduled maintenance procedures as prescribed in your MRC cards. Proof of scheduled maintenance is required to maintain the warranty;
- improper maintenance;
- damage in shipment;
- abnormal use;
- removal, alteration, or obliteration of either the rating plate or the date code on the heating elements;
- operating the frypot without shortening or other liquid in the frypot;
- no fryer will be warranted under the ten-year program for which a proper start-up form has not been received.

This warranty also does not cover:

- transportation or travel over 100 miles/160 km (50 miles/80 km each way), or travel over two hours;
- overtime or holiday charges;
- consequential damages (the cost of repairing or replacing other property which is damaged), loss of time, profits, use or any other incidental damages of any kind.

There are no implied warranties of merchantability or fitness for any particular use or purpose.

This warranty is applicable at the time of this printing and is subject to change.

BIGL30 SERIES GAS FRYER

CHAPTER 1: SERVICE PROCEDURES

1.1 Functional Description

BIGL30 series gas fryers contain a welded stainless steel frypot that is directly heated by a high efficiency infrared burner system, requiring approximately 43% less energy than conventional burners to cook the same volume.

Self-contained combustion chambers (referred to as “burners”) are fitted into rails attached to the sides of the frypot, one on each side. Each combustion chamber is fitted with special ceramic tiles that are heated by the burning of a forced air/gas mixture. The tiles transfer heat to the frypot by means of infrared radiation, providing much more constant and uniform heat dispersion over the surface of the frypot than conventional burners. Because less heat is lost to the atmosphere in the process, compared to “open-burner” designs, less fuel is required to achieve and maintain a given frypot temperature.

In full-vat units, gas flow to both of the burners is regulated by one electromechanical gas valve. All fryers in this series are equipped with 24 VAC gas valve systems, and all are configured with electronic ignition.

1.2 The Electronic Ignition System

An ignition module mounted below the component box (located behind the control panel) is connected to an ignitor assembly at the burner. The ignition module performs five important functions: it provides fuse protection for the 24-volt circuit, provides an ignition spark, supplies voltage to the gas valve, provides the alarm circuit (24V) to the controller and proofs the burner flame. The module contains a four second time delay circuit and a coil that activates the gas valve.

The ignitor assembly consists of a spark plug, an enrichment tube, and a flame sensor.

At start-up, the power switch is placed in the ON position, supplying approximately 12-volts DC to the heat-control circuitry in the controller and to one side of the heat relay coils on the interface board. If resistance in the temperature probe indicates the temperature in the frypot is below 180°F (82°C), the current flows through a melt cycle circuit where a timer switch alternately closes for six seconds and opens for 24 seconds. If the temperature is 180°F (82°C) or above, the current flows through a heat circuit, bypassing the timer switch. In either case, ground is supplied to the other leg of the heat relay coils, which closes electronic switches in the 24 VAC circuit to provide current to the ignition module. Circuitry in the ignition module sends 24 VAC to the gas valve via a normally closed high-limit switch. Simultaneously, the module causes the ignitor to spark for four seconds to light the burner. A flame sensor verifies the burner ignition by measuring the flow of microamps through the flame. If the burner does not light (or is extinguished), current to the ignition module is cut, the gas valve closes, and the ignition module “locks out” until the power switch is turned off and then back on. A normally closed drain switch is attached to the rear of the controller. If the drain is opened, the heat circuit is opened and all heating is discontinued. A probe monitors the temperature in the frypot. When the programmed setpoint temperature is reached, resistance in the probe causes the heat cycle circuitry in the controller to cut off current flow through the heat relay. This in turn cuts off the 24 VAC to the ignition module, causing the gas valve to close.

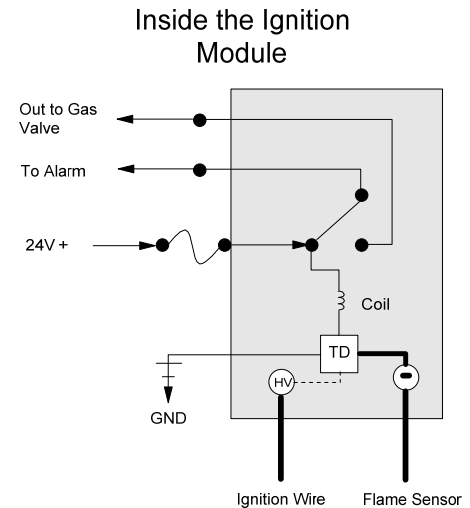

1.3 Interface Board

All fryers in this series have an interface board located in the component box behind the control panel. The interface board provides a link between the controller and the fryer's individual components without requiring excessive wiring, and allows the controller to execute commands from one central point.

K2 and K3 are double-pole-double throw (DPDT) relays that supply 24VAC to the ignition and gas valve circuits, as well as 120VAC to the blower motor. The relays on this board plug into sockets. If a relay fails, that relay can be replaced.

LEDs (labeled D1 through D7) are arrayed around the board to assist in troubleshooting.

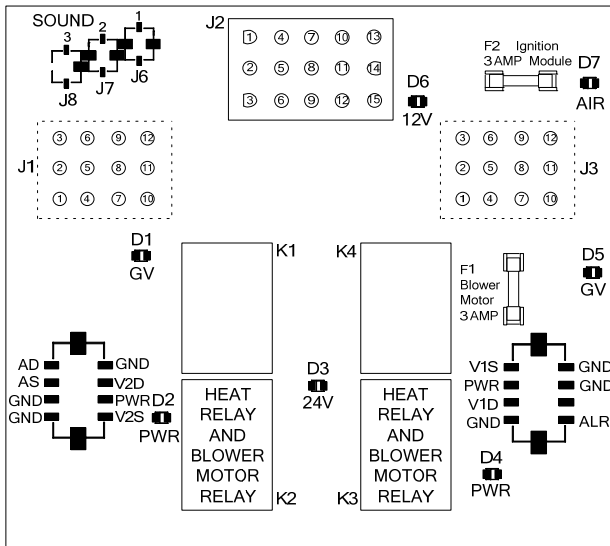

INTERFACE BOARD 106-6708

INTERFACE BOARD LED DIAGNOSTIC LIGHTS	
D1	24 VAC to left gas valve (dual vat only)
D2	24 VAC to left ignition module (dual vat only)
D3	24 VAC from transformer
D4	24 VAC to right ignition module
D5	24 VAC to gas valve (right valve if dual vat)
D6	12 VAC from transformer
D7	CE and Japanese units only: air switch closed

NOTE: In full-vat fryers, the relay for the left side (K2) may not be present.

The chart on the following page illustrates current flow through the board, and the table at the top of page 1-4 identifies frequently used test points.

INTERFACE BOARD

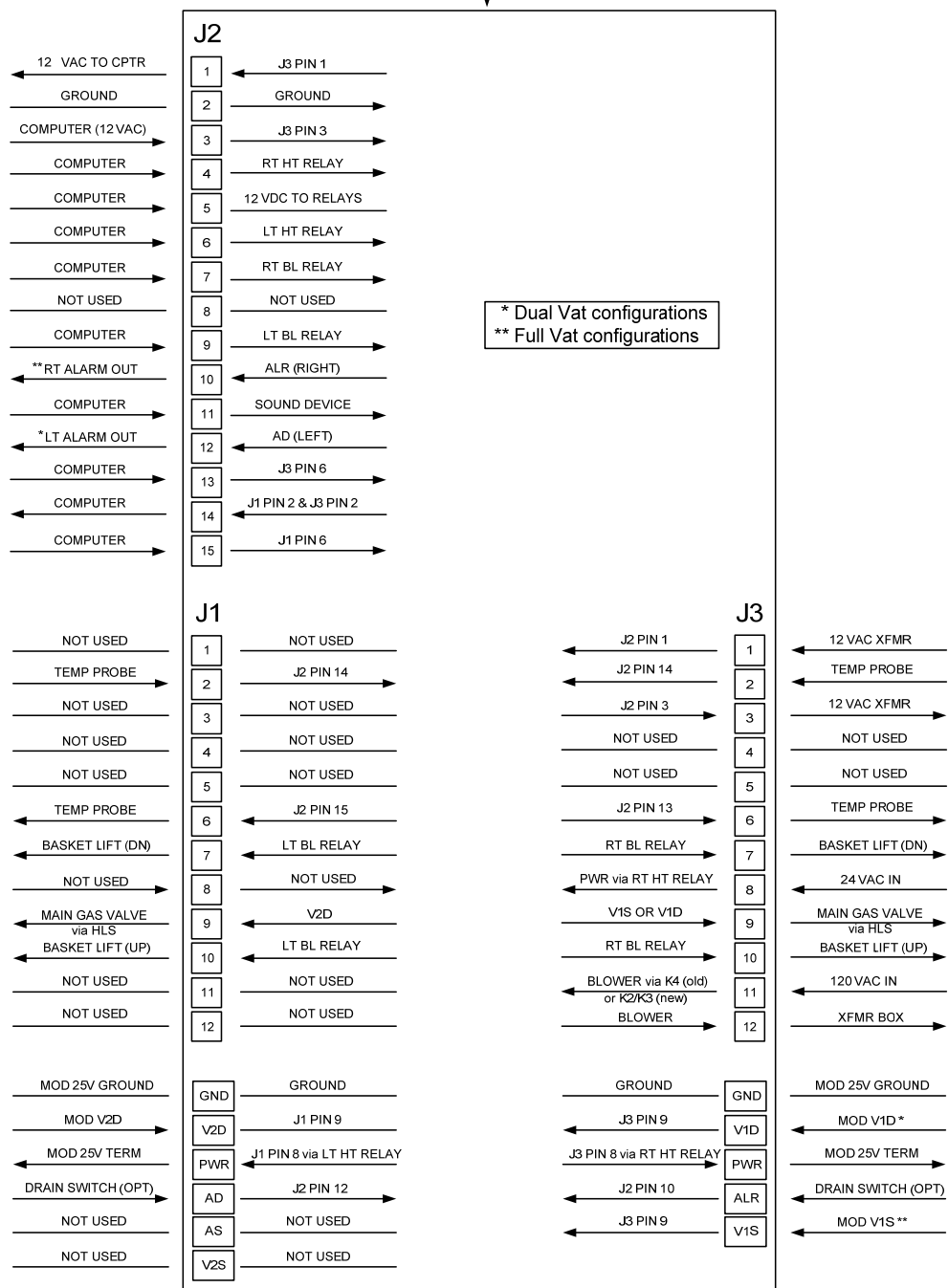

LEFT VAT

FULL OR RIGHT VAT

CURRENT FLOW THROUGH INTERFACE BOARD

FREQUENTLY USED TEST POINTS FOR INTERFACE BOARD			
TEST	METER SETTING	PINS	RESULTS
12VAC Power to Controller	50VAC Scale	1 and 3 on J3 or J2	12-18
24VAC Power to Right Module	50VAC Scale	8 on J3 and GROUND	22-28
120 VAC Power	250VAC Scale	11 on J3 and GROUND	110-125
120 VAC Power to Blowers	250VAC Scale	12 on J3 and GROUND	110-125
24VAC Power to Full or Right vat High-Limit	50VAC Scale	9 on J3 and GROUND	22-28
24VAC Power to Left High-Limit (if present)	50VAC Scale	9 on J1 and GROUND	22-28
Probe Resistance (Full or Right Vat) *	R x 1000 OHMS	2 and 6 on J3 or 13 and 14 on J2	**
Probe Resistance (Left - if present) *	R x 1000 OHMS	2 and 6 on J1 or 14 and 15 on J2	**
Probe Isolation	R x 1000 OHMS	6 on J1 or J3 and GROUND	***
High-Limit Continuity (Full or Right Vat)	R x 1 OHM	9 on J3 and Wire 13C on Gas Valve	0
High-Limit Continuity (Left - if present)	R x 1 OHM	9 on J1 and Wire 12C on Gas Valve	0
<p>* Disconnect 15-pin harness from controller before testing probe circuit.</p> <p>** See Probe Resistance Chart on page 1-28.</p> <p>*** 5 mega-Ohms or greater.</p>			

1.4 Thermostats

BIGL30 series gas fryers have temperature probes located on the front centerline of each frypot. In this type of thermostat, the probe resistance varies directly with the temperature. That is, as the temperature rises, so does resistance, at a rate of approximately 2 ohms for every 1° F. Circuitry in the controller monitors the probe resistance and controls burner firing when the resistance exceeds or falls below programmed temperatures (setpoints).

BIGL30 series gas fryers are also equipped with a high-limit thermostat. In the event that the fryer fails to properly control the oil temperature, the high-limit thermostat prevents the fryer from overheating to the flash point. The high-limit thermostat acts as a normally closed power switch that opens when exposed to temperatures above 425°F to 450°F (218°C to 232°C). The different types of thermostats have different part numbers for CE and Non-CE models, and are not interchangeable.

1.5 Accessing Fryers for Servicing

DANGER

Moving a fryer filled with oil may cause spilling or splattering of the hot liquid. Follow the draining instructions in Chapter 5 of the BIGL30 Series Gas Fryer Installation and Operation Manual before attempting to relocate a fryer for servicing.

1. Shut off the gas supply to the unit. Unplug the power cords. Disconnect the unit from the gas supply.
2. Remove any attached restraining devices and relocate the fryer for service accessibility.
3. After servicing is complete, reconnect the unit to the gas supply, reattach restraining devices, and plug in the electrical cords.

1.6 Cleaning the Gas Valve Vent Tube

1. Set the fryer power switch and the gas valve to the OFF position.
2. Carefully unscrew the vent tube from the gas valve. **NOTE:** The vent tube may be straightened for ease of removal.
3. Pass a piece of ordinary binding wire (.052 inch diameter) through the tube to remove any obstruction.
4. Remove the wire and blow through the tube to ensure it is clear.
5. Reinstall the tube and bend it so that the opening is pointing downward.

1.7 Checking the Burner Manifold Gas Pressure

1. **On non-CE fryers only** ensure that the gas valve knob is in the OFF position.

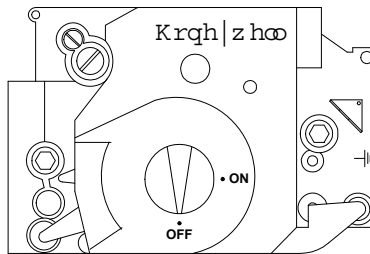

2. Remove the pressure tap plug from the gas valve assembly.

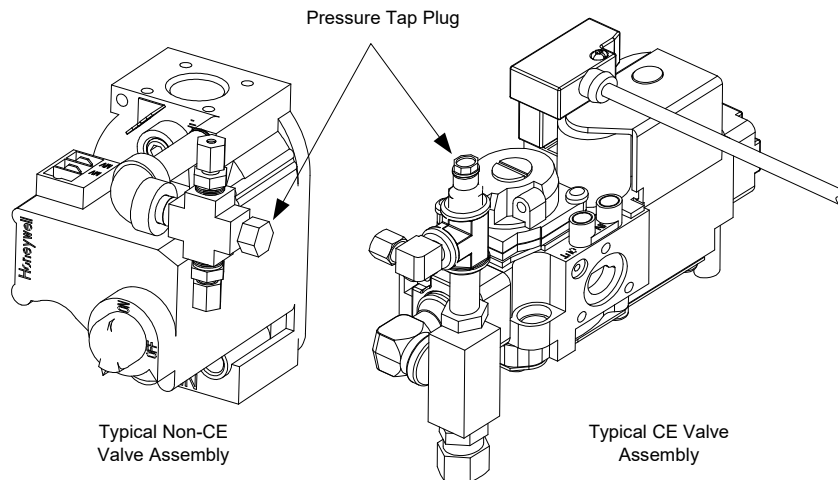

3. Insert the fitting for a gas pressure-measuring device into the pressure tap hole.
4. **On non-CE fryers only**, place the gas valve in the ON position.
5. Place the fryer power switch in the ON position. When the burner has lit and burned steadily for at least one minute, compare the gas pressure reading to the pressure for the corresponding gas in the appropriate table on the following page. The tables list the burner manifold gas pressures for each of the gas types that can be used with this equipment.

CE Standard Burner Manifold Gas Pressures	
Gas	Pressure (mbar)
	Single Vat
Natural Gas Lacq (G20) under 20 mbar	7
Natural Gas Gronique * (G25) under 25 mbar	10
Natural Gas Gronique (G25) under 20 mbar	10
Butane/Propane (G30) at 28/30 or 50 mbar	17
Propane (G31) under 37 or 50 mbar	20

* Belgian G25 = 7,0 mbar

Non-CE Standard Burner Manifold Gas Pressures	
Gas	Pressure
Natural	3" W.C. 0.73 kPa
Propane	8.25" W.C. 2.5 kPa

6. To adjust the burner gas pressure, remove the cap from the gas valve regulator and adjust to the correct pressure.

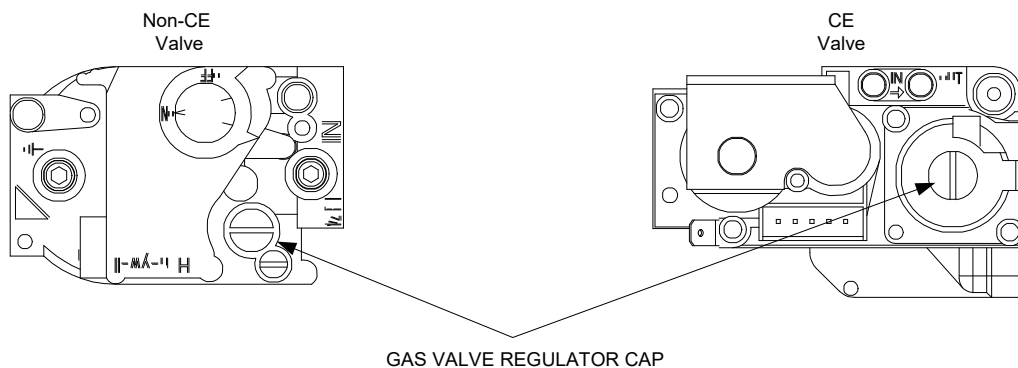

7. Place the fryer power switch (and the gas valve in non-CE fryers) in the OFF position. Remove the fitting from the pressure tap hole and reinstall the pressure tap plug.

1.8 Measuring Flame Current

When the burner flame is properly adjusted, it will produce a current between 2.5 μA and 3.5 μA . Flame current is measured by placing a *microamp* (not milliamp) meter in series with the sensing wire on the ignitor. This is accomplished as follows:

1. Place the fryer power switch in the OFF position.

2. Disconnect the sensing wire from one of the burner ignitors and connect it to the positive lead of the meter. Connect the negative lead of the meter to the terminal from which the sensing wire was removed.

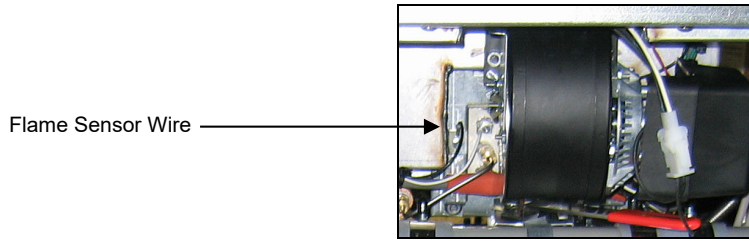

3. Place the fryer power switch in the ON position to light the burners. After the frypot temperature reaches 200°F (93°C), wait at least one minute before checking the reading. **NOTE:** The closer the unit is to normal operating temperature, the more accurate the reading will be.

1.9 Replacing Fryer Components

1.9.1 Replacing the Controller or the Controller Wiring Harnesses

1. Disconnect the fryer from the electrical power supply.
2. Open the control panel by removing the screws on the bottom of the bezel. Carefully lower the bezel.
3. Remove the two screws from the upper corners of the controller. The controller is hinged at the bottom and will swing open from the top.
4. Unplug the wiring harnesses from the connectors on the back of the controller marking their position for reassembly and disconnect the grounding wires from the terminals. Remove the controller by lifting it from the hinged slots in the control panel frame.

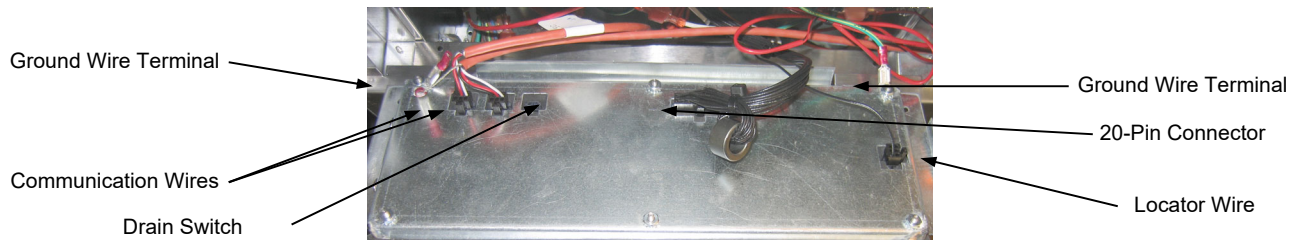

Manual M3000 controller.

5. Install the replacement controller. Reverse steps 1 thru 4.
6. Setup the manual M3000 controller following the instructions in the Installation and Operation manual. Setup **MUST** be performed after replacement.
7. Once setup is complete on all replaced controllers, reset all control power following the instructions in section 1.13.6 to readdress the new controller. Check software version and if necessary update the software. If a software update was necessary, follow the instructions to update the software in section 1.15 on page 1-34.

1.9.2 Replacing the Temperature Probe, High-Limit Thermostat

1. Disconnect the fryer from the electrical supply.
2. Drain cooking oil below the level of the probe or thermostat.
3. Remove the screws on the bottom of the bezel. Carefully lower the bezel.
4. Remove the top two screws in the upper corners of the controller.
5. Swing the controller out from the top and allow it to rest on its hinge tabs.
6. Disconnect the controller wiring harness(es) and ground wire from the back of the controller and remove the controller by lifting it from the hinge slots in the control panel frame.
7. Disconnect the ignition cables from the ignitors by grasping the boots and gently pulling toward you.
8. Disconnect the flame sensor wires from the flame sensors.
9. Disconnect the sound device lead from the interface board.
10. If working on the left frypot, cut the wire tie on the wiring bundle and disconnect the main wiring harness 15-pin connector.

11. Remove the spark module boxes.
12. Remove the component box mounting screws.
13. Lower the component box far enough to expose the probes and carefully disconnect the wiring harness plug from the back of the box. This will leave one set of wires, enclosed in spiral wrap, connected to the component box.
14. Unscrew the probe or thermostat from the frypot.
15. Apply Loctite® PST56765 pipe thread sealant or equivalent to the replacement part threads and screw the replacement part into the frypot, torquing to 180 inch-pounds.
16. Connect the wires from the new component as follows:
 - a. If replacing the temperature probe, use a pin pusher to disconnect (one at a time) the red and white leads from the connector and insert the corresponding leads from the new probe into the plug..
 - b. If replacing the high-limit thermostat, use a pin pusher to disconnect the lead running to the connector and insert the corresponding lead from the new thermostat.
 - c. Disconnect the other lead from the drain safety switch and connect the remaining lead from the new thermostat.
17. Reverse steps 1 through 13 to complete the procedure.

1.9.3 Replacing the Interface Board

1. Perform steps 1 through 4 from section 1.9.1.
2. Disconnect the wires attached to the interface board, marking or making a note of the wires and terminals to facilitate reconnection.
3. Remove the nuts at each corner of the interface board and carefully pull it from the studs far enough to allow the connector on the back of the board to be disconnected, then remove the board from the box. When removing the board, be careful not to lose the spacers that fit over the studs behind the board.
4. Recover the relay(s) from the failed interface board and install on the replacement board.
5. Reverse the procedure to install the replacement board, being sure that the spacers behind the board are in place and the computer locator ground wire is attached to a stud.

1.9.4 Replacing an Ignition Module

1. Disconnect the fryer from the electrical supply.
2. Remove the screws on the bottom of the bezel. Carefully lower the bezel.
3. Remove the top two screws in the upper corners of the controller.
4. Swing the controller out from the top and allow it to rest on its hinge tabs.
5. Loosen the nuts attached to the screws of the module. Slide the module towards the rear of the component box until the nuts drop through the keyholes.
6. Carefully rotate the module and pull forward. On some units it may be necessary to remove the blower.
7. Disconnect the wires from the ignition module, marking or making a note of the wires and terminals to facilitate reconnection.
8. Remove the screws from the module.
9. Move the screws and spacers to the new module.
10. Reverse the procedure to install the replacement module.

1.9.5 Replacing an Ignitor Assembly



Drain the frypot or remove the handle from the drain valve before proceeding further.

1. Disconnect the fryer from the electrical supply.
2. Disconnect the flame sensor wire by carefully pulling its push-on terminal from the terminal strip on the ignitor. Disconnect the gas enrichment tube at the ignitor-end compression fitting. Disconnect the ignition cable from the ignitor by grasping its boot and gently pulling toward you. (See photo below)

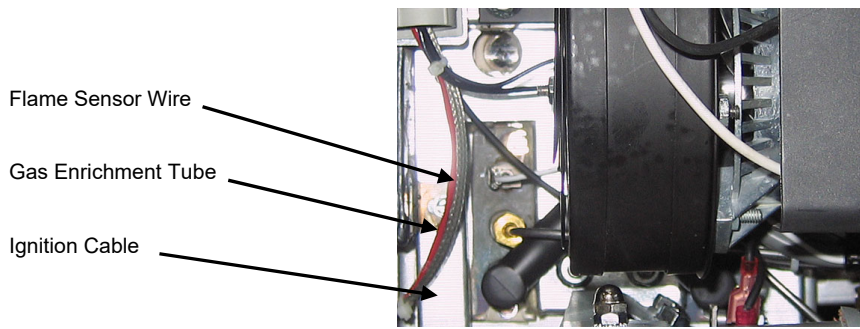

3. Remove the sheet metal screws securing the ignitor to the mounting plate and pull the ignitor from the fryer.
4. Reverse the procedure to install the replacement ignitor.

1.9.6 Replacing or Cleaning a Combustion Air Blower

1. Disconnect the blower wiring harness, remove the blower assembly mounting nuts, and remove the blower assembly from the fryer. If cleaning the motor, continue with Step 2; otherwise, install the replacement blower, reconnect the wiring harness, and then go to Step 6.

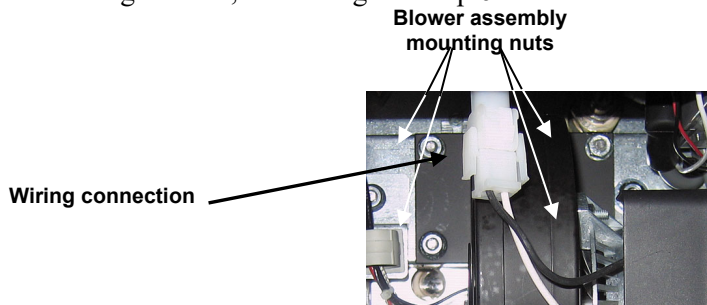

2. Remove the blower motor shield and separate the blower motor from the housing as shown in the illustration below.

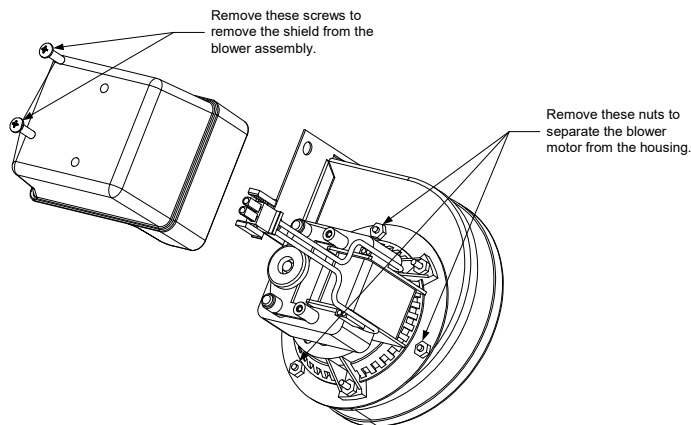

3. Wrap the motor with plastic wrap to prevent water from entering it. Spray degreaser or detergent on the blower wheel and the blower housing. Allow it to soak for five minutes. Rinse the wheel and housing with hot tap water, then dry with a clean cloth.

NOTICE- Australia Only
The air pressure switch on the combustion blower should read: Full Vat units-122pa (0.5 inches W.C.) and for Split Vat units-180pa (0.72 inches W.C.).

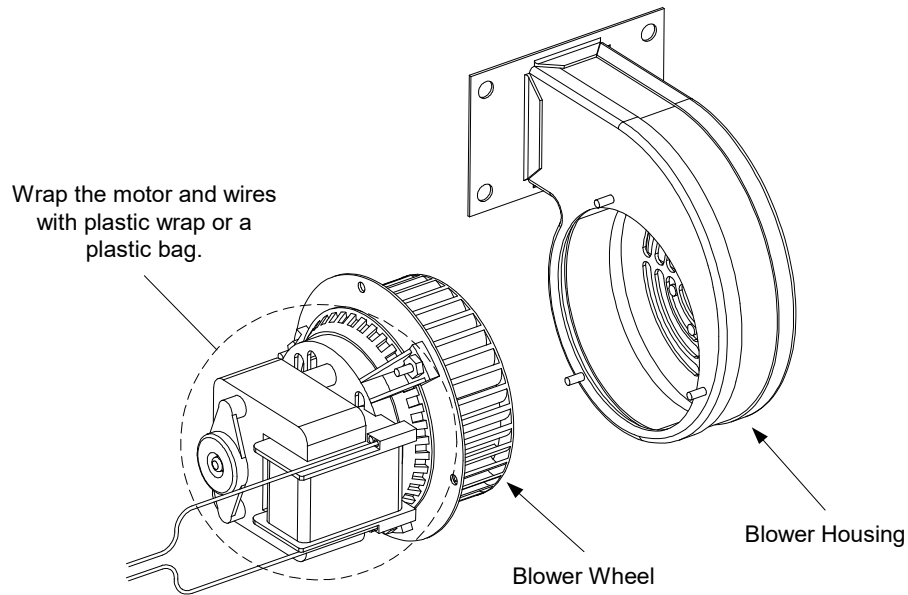

4. Remove the plastic wrap from the blower motor assembly. Reassemble the blower motor assembly and blower housing. Reinstall the blower shield.
5. Reinstall the blower assembly in the fryer and reconnect the wiring disconnected in Step 1.
6. Light the fryer in accordance with the procedure described in Chapter 3, Section 3.2.2 of the BIGL30 Series Gas Fryer Installation and Operation Manual.
7. After the burners have been lit for at least 90 seconds, observe the flames through the burner viewing ports located on each side of the combustion air blower.

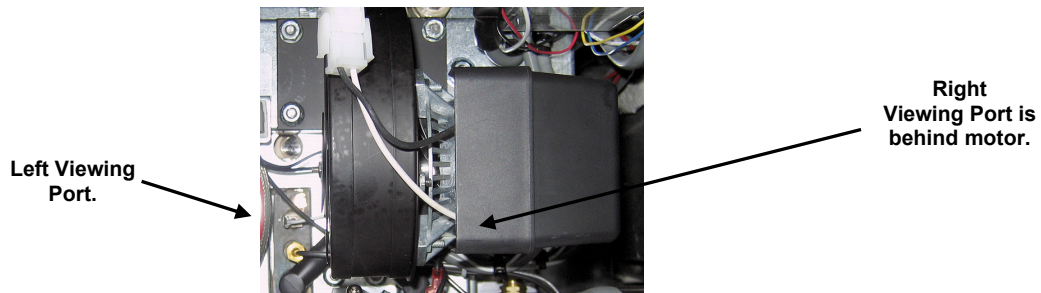

The air/gas mixture is properly adjusted when the burner manifold pressure is in accordance with the applicable table on page 1-6 and the burners display a bright orange-red glow. If a blue flame is observed or if there are dark spots on a burner face, the air/gas mixture requires adjustment. **NOTE: Opening the air shutter too much may result in whistling. It should not be more than 1/3 open.**

1.9.7 Adjusting the Air/Gas Mixture

On the side of the blower housing opposite the motor is a shutter plate with a locking nut. Loosen the nut enough to allow the shutter to be moved, then adjust the position of the shutter to open or close the air intake opening until a bright orange-red glow is obtained. Carefully hold the shutter in position and tighten the locking nut (see illustration on the following page).

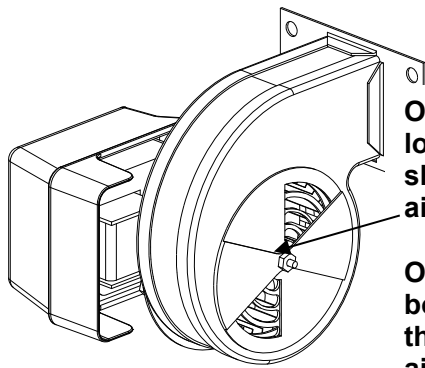

On non-CE blowers, loosen this nut and rotate shutter to open or close air intake.

On CE blowers, loosen both wing nuts and slide the shutter to adjust the air intake.

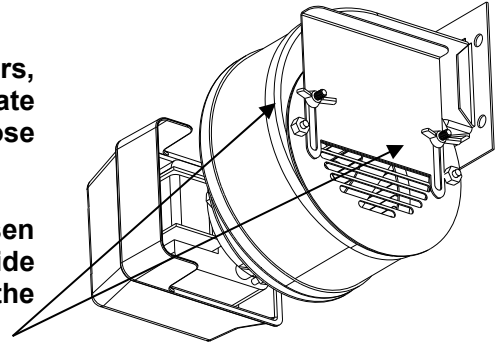

1.9.8 Replacing a Gas Valve

1. Disconnect fryer from electrical and gas supplies.
2. Disconnect the drain safety and high-limit thermostat wires from the gas valve. Mark each wire to facilitate reconnection.
3. Remove the vent tube (on non-CE fryers) and the enrichment tube fitting from the valve. Disconnect the flexible gas line(s).

If replacing the left-most valve on any configuration, or the right valve on a two-fryer battery, follow the instructions below. If replacing valves in other positions, skip to “ALL OTHER VALVES.”

- A. Remove the filter pan from the unit. Remove the door adjacent to the valve being replaced.
- B. Remove the screws that attach the pan rails adjacent to the valve being replaced.
- C. Uncouple the pipe union and remove the gas valve and associated piping from the unit.
- D. Remove the fittings and associated piping from the failed valve and install them on the replacement valve using Loctite® PST56765 or equivalent pipe thread sealant.
- E. Reconnect the gas valve assembly to the fryer using Loctite® PST56765 or equivalent pipe thread sealant, and reattach the flexible gas line(s), enrichment tube(s), and the vent tube (on non-CE units). Reconnect the high-limit thermostat wires and drain safety wires to the valve.
- F. Reconnect the fryer to the gas supply and open the cut off valve. Apply a thick soapy solution of water around each connection to check for gas leaks and ensure there are no bubbles. Eliminate any that are found. There should be no smell of gas.
- G. Position the pan rail assembly beneath the fryer and rest the rear end of the rail on the cabinet frame. Install the two nuts and bolts behind the front face of the rail, but do not tighten them. Install the nut and bolt at the rear end of the filter rail and tighten securely.
- H. Reattach the screws for the pan rails. Install the filter pan in the unit to make sure that all components are properly aligned.
- I. Reconnect the fryer to the electrical power supply and check for proper operation. When proper operation has been verified, reinstall the door removed in Step A.

ALL OTHER VALVES

4. Carefully unscrew the valve from the manifold. **NOTE:** Some models may have the valve attached to the manifold by means of a pipe union. In such cases, remove the valve by uncoupling the union.
5. Remove all fittings from the old gas valve and install them on the replacement valve, using Loctite® PST56765 or equivalent pipe thread sealant.
6. Reconnect the gas valve assembly to the fryer using Loctite® PST56765 or equivalent pipe thread sealant, and reattach the flexible gas line(s), enrichment tube(s), and the vent tube (on non-CE units). Reconnect the high-limit thermostat wires and drain safety wires to the valve.
7. Reconnect the fryer to the gas supply and open the cut off valve. Apply a thick soapy solution of water around each connection to check for gas leaks and ensure there are no bubbles. Eliminate any that are found. There should be no smell of gas.
8. Reconnect the fryer to the electrical power supply and check for proper operation.

1.9.9 Replacing a Burner Assembly

1. Disconnect the unit from the electrical and gas supplies.
2. Remove the gas line and enrichment tube using a 7/16" and 5/8" wrench from the front of the burner.
3. Remove the elbow and tee off the bottom of the burner to ensure easier removal of the burner.
4. Remove the fryer back.
5. Remove the screws attaching the flue cap to the brace.
6. Remove the top cross brace in the back.
7. Remove the flue by removing the two screws in the rear and one screw in the front of the flue.

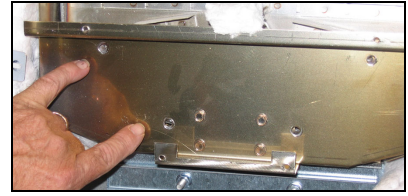

Figure 1

8. Remove all the screws on the flue collector and bend back the tabs and remove the collector.
9. Remove four screws on the collector insulation plate (see Figure 1).
10. Remove the four nuts and cover of the lower insulation retaining cover (see Figure 2).
11. Carefully remove the insulation.
12. Grasp the burner firmly and slide the burner out the rear of the fryer. Pull it toward you until it clears the burner channels, taking care not to damage the ceramic tiles in the process.

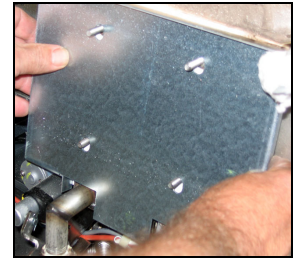

Figure 2

13. Slide the burner out the rear of the fryer.
14. Clean all debris from the burner channels and combustion area.
15. Inspect the upper and lower burner rails for cracked or burned out welds.
 - a. If the welds in the lower rail are cracked or burned out, the frypot must be replaced. Refer to Section 1.9.11 for procedure.
 - b. If the welds in the upper rail are cracked or burned out, the upper rail must be replaced. Refer to Section 1.9.12 for procedure.
16. Wrap a new insulating strip along the edges of the burner. **NOTE:** Use P/N 826-0931 for full-vat frypots and P/N 826-0932 for dual-vat frypots.
17. Carefully slide the replacement burner into the rails starting at the top and lifting slightly up on the bottom (see Figure 3). Ensure that the insulation is not torn or damaged.

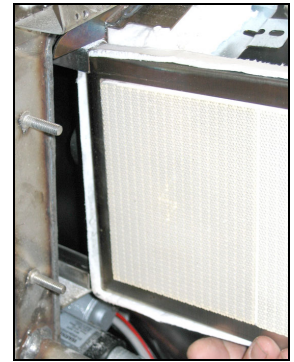

Figure 3

18. In reverse order, reassemble insulation and holding plates.
19. Install flue collector.
20. Install the flue.
21. Install the cross brace, ensuring the flue cap is secured to the brace.
22. Replace the fryer back.
23. Reattach the elbow, gas line and enrichment tubes to the front of the burner.
24. Fill the frypot with oil. Turn the fryer on; turn off or bypass the melt cycle and operate the unit for at least 10 minutes.
25. Examine the burner flame. The color and intensity on both sides should be the same.
26. Use an inspection mirror to check for leaks in areas that cannot be directly observed.
27. If a leak is detected, tighten all the lower insulation retainer nuts, allow the frypot to heat for five additional minutes, and repeat steps 25 and 26.
28. If a leak persists, use a rubber hammer and a small block of wood to tap the corners of the lower combustion chamber insulation retainers. Repeat steps 25 through 27. **Repeat this step until no leakage is detected.**

1.9.10 Replacing the Filter Motor, Filter Pump, or Filter Pump Solenoid Valve

1. Disconnect the unit from the electrical power supply.
2. Remove the filter pan from the unit.
3. Position a container beneath the oil return fitting at the front of the cabinet. Disconnect the flexible oil lines from the fittings, allowing any residual oil to drain into the container.
4. At the rear of the fryer, unplug the left connector (as viewed from the rear of the fryer) from the transformer box.
5. Remove the four nuts and bolts attaching the motor mount to the rear motor mount support.
6. At the front of the fryer, remove the cover plate from the front of the motor and disconnect the motor wires.
7. Place a 1-foot (30.5-cm) length of wood (or similar support) beneath the motor mount near the front of the unit and remove the two remaining nuts and bolts attaching the motor mount to the front cabinet cross-brace.
8. Carefully remove the support and lower the motor mount to the floor, allowing the rear of the mount to slide forward and off the rear motor mount support.
9. Disconnect the return flexline from the pump. The motor and pump assembly can now be pulled from beneath the fryer and the failed component can be removed and replaced.
10. Position the replacement motor and pump assembly beneath the fryer and reconnect the oil return flexline to the pump. Lift the rear of the motor mount up and onto the rear motor mount support.
11. Lift the front of the motor mount up and support it with a 1-foot (30.5-cm) piece of wood or a similar support. Install but do not tighten the two nuts and bolts that attach the motor mount to the front cabinet cross-brace.
12. Install and tighten the four nuts and bolts that secure the motor mount to the rear motor mount support.
13. At the front of the fryer, tighten the two nuts and bolts at the front of the motor mount. Reconnect the motor power wires and reinstall the wiring cover plate.
14. Reconnect the oil return flexline and reinstall the filter pan.
15. Reconnect the unit to the electrical power supply, fill the frypots with oil and check for proper operation.

1.9.11 Replacing the Frypot

1. Disconnect the fryer from the electrical and gas supplies.
2. Remove the filter pan from the unit and drain one frypot at a time into a Shortening Disposal Unit (SDU) or other appropriate metal container.



DO NOT attempt to drain more than one full frypot into the SDU at one time.

3. Open the control panel by removing the two screws on the bottom of the bezel. Carefully lower the bezel.
4. Remove the top screws in the upper corners of the controller.
5. Grasp the upper edge of each controller and swing the controller downward. Unplug the controller wiring harness and grounding wire from the back of each controller.
6. Remove the controllers by lifting them from the hinge slots in the control panel frame.
7. Disconnect the sound device wire from the interface board.
8. Disconnect the flame sensor wires by carefully pulling the push-on terminals from the terminal strips on the ignitors. Disconnect the gas enrichment tube at the ignitor-end compression fitting. Disconnect the ignition cables from the ignitors by grasping the boots and gently pulling toward you.
9. Dismount the topcap by removing the screws on the bottom of each front corner and lifting the topcap straight up.
10. Remove the two mounting screws on each side of the component box and rotate the top of the box out of the frame. Carefully pull it out enough to disconnect the wiring harness connector from the back of the box. Cut any ties that prevent the box from being pulled out of the control panel frame.
11. Carefully pull the box clear of the frame and rest it on top of the fryer.
12. Using a pin pusher, remove the temperature probe, high-limit thermostat wires and RTD probe wires from the plugs or terminals, marking each wire to facilitate re-assembly.
13. Remove the cover from the safety drain switch. Disconnect the wires from the switch.
14. Disconnect any auto top-off sensors if equipped and wiring.
15. Remove the section(s) of drain from the drain valve(s) of the frypot to be removed.

16. Disconnect the gas lines from the burner orifices and ignitor assemblies.
17. Remove the frypot hold down bracket.
18. Remove the screws in the back panel and inside the flue cap at each end that secure the flue cap to the fryer and lift it clear of the fryer.
19. Disconnect the oil return line(s) from the frypot to be removed.
20. Carefully lift the frypot from the fryer cabinet.
21. Remove the drain valve(s), temperature probe(s), high-limit thermostat(s), RTD probes and igniter assemblies. Inspect each of these components carefully and install them in the replacement frypot if they are in serviceable condition. Use Loctite® PST56765 sealant or equivalent on component threads.
NOTE: Some servicers, based upon their experience, recommend that probes and thermostats be replaced whenever a frypot is replaced; however, this remains the customer's decision.
20. Reverse steps 1-19 to reassemble fryer.
NOTE: Care should be taken not to over-torque nuts on frypots made of 400-series stainless steel, as this could tear the material. One turn past hand-tight is sufficient torque.
21. Perform steps 14 through 18 of Section 1.9.9 to ensure that there are no leaks in the burner insulation.

 **CAUTION**

Before installing temperature probe, high-limit thermostat, RTD probe and drain valve on replacement frypot, clean the threads and apply Loctite® PST56765 thread sealant or equivalent.

1.9.12 Replacing Frypot Insulation and/or Upper Burner Rails

NOTE: Replacing the burner rails requires completely tearing down the frypot and installing new frypot insulation. Refer to the frypot exploded view (on next page) for component identification.

1. Remove the frypot per Section 1.9.11.
2. Remove the burner assemblies (1).
3. Remove insulation retainers and blanket insulation (2).
4. Remove the upper oil zone insulation bracket and upper oil zone insulation (3).
5. Remove the plenum (4).
6. Remove the front lower combustion chamber insulation retainer and insulation (5) and the front lower combustion chamber inner insulation retainer and insulation (6). **NOTE:** Full-vat units have two-piece insulation retainer and insulation components. Dual-vat units have one-piece components.
7. Remove the upper combustion chamber insulation retainer and insulation (7).
8. Remove the inner upper combustion chamber insulation retainer and insulation (8).
9. Remove the rear lower combustion chamber retainers, back, and insulation (9). **NOTE:** Full-vat units have two-piece backs and four retainers. Dual-vat units have one-piece backs and two retainers.
10. Remove the flue assembly (10).

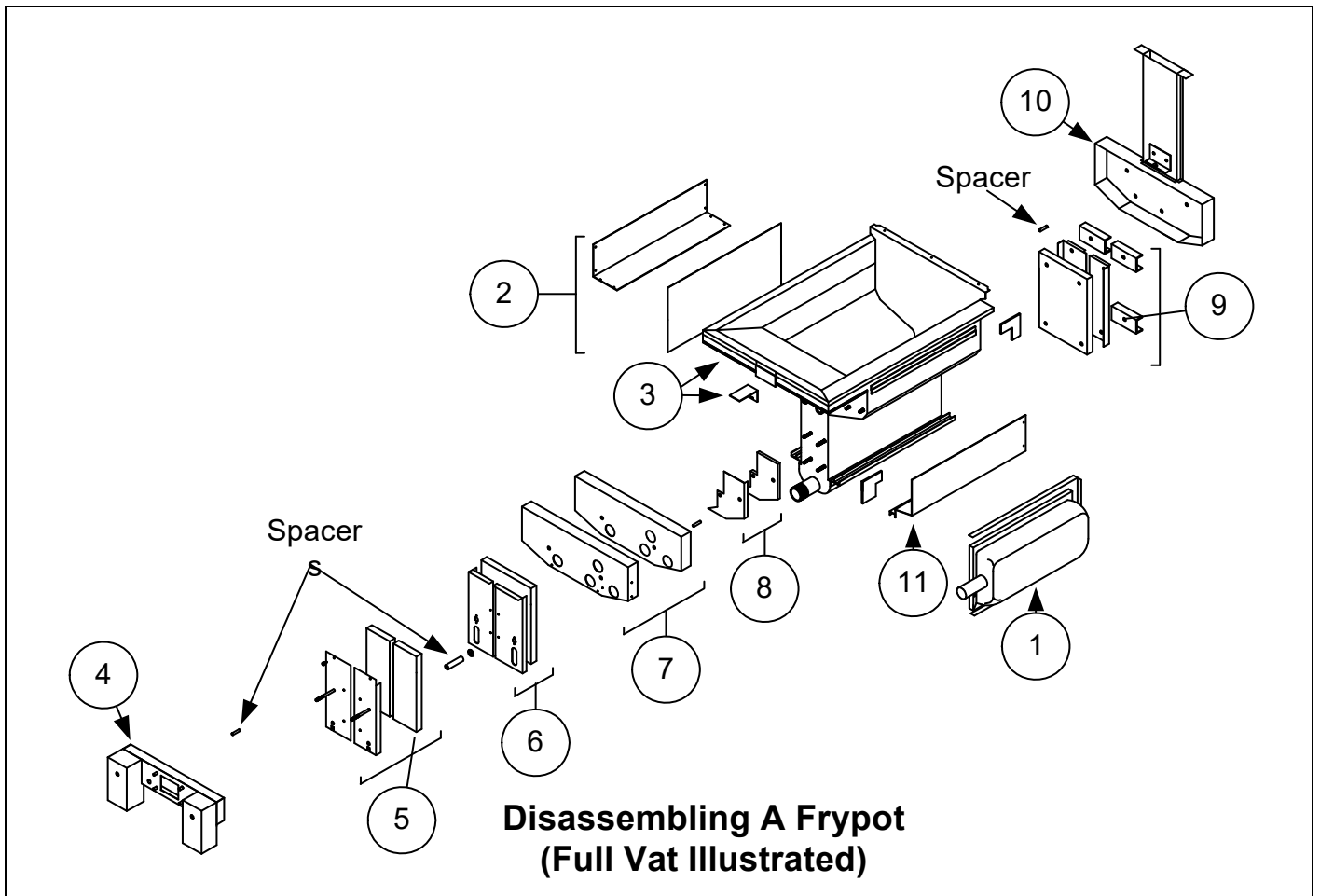

See page 1-17 for reassembly illustration.

11. Remove the upper burner rails (11). **NOTE:** For the following steps, refer to the frypot exploded view on page 1-15 for component identification.
12. Remove any residual insulation, sealant, and/or oil from the exterior of the frypot.
13. Place the “L” shaped pieces of the combustion chamber insulation (1) in the front and rear corners of both upper rail-retaining slots. (See page 1-17).
14. Using a mallet and short piece of wood, tap the corner tabs of the combustion chamber over the insulation to ensure a solid seal of the burner.
15. Install the upper burner rails (2) with the heat deflectors slanting toward the rear of the frypot. The rails will cover the “L” shaped pieces of combustion chamber insulation previously installed.
16. Place the upper inner combustion chamber insulation and insulation retainers (3) on the top two studs on each side of the front of the frypot and secure with ¼”-20 washer-nuts. *It is normal for the retainers to slice off the overhanging insulation.*
17. Place the lower rear combustion chamber insulation (4) on the lower four studs at the rear of the frypot.
18. Place one 1.625-inch tubular spacer (5) on each of the flue assembly (upper) studs at the rear of the frypot. **NOTE:** There are three different sizes of spacers. Verify the size to ensure the correct spacers are installed.
19. Press the flue assembly (6) over the burner rails. It may be necessary to use a rubber mallet or screwdriver to align the components. Use four ¼”-20 washer nuts to secure the flue assembly. **Do not tighten the retainer nuts at this point. They should be finger-tight only.** **NOTE:** The flue edge will cover one to two inches of the lower insulation.
20. Install the lower rear combustion chamber back(s) and retainer(s) (7) with the flanged edge(s) against the flue. Secure with ¼”-20 washer nuts. **NOTE:** Full-vat units have two-piece backs and four retainers. Dual-vat units come with one-piece backs and only two retainers.

21. Insert the burners (9) into the rails to ensure the rail spacing and alignments are correct. The burner should slide freely into and out of the rails. The upper rail can be bent slightly to increase or decrease tension on the burner and the edges of the slot can be closed or opened slightly to best fit the burner frame.
22. Carefully wrap a strip of burner insulation (8) tightly around the rear and sides of the burner frame (9), with the glass-tape side of the strip on the outside. **Do not use duct tape or adhesive to secure the strip to the burner frame.**
23. Align the burner to the burner rails while maintaining tension on the insulation strip. Insert the burner at a slight angle and begin pushing the burner slowly into the rails until it contacts the rear combustion chamber. The fit should be snug, but not excessively tight.
24. Verify that the burners are flush with the front edge of the burner rails. Remove the excess burner insulation by cutting with a knife or diagonal pliers. **Do not try to tear the insulation!**
25. Insert the upper front insulation (10) into its retainer (11), making sure that the holes in each piece are aligned with one another. Install the assembly with the insulation side toward the frypot and secure with ¼”-20 washer-nuts. **Do not over tighten.**
26. Place a washer on each of the four lower studs on the front of the frypot. Install the lower inner front insulation (12) with the rectangular openings toward the drain valve nipple. Install the lower inner front insulation retainer(s) (13). **NOTE:** Full-vat units have a two-piece insulation retainer. Dual-vat units have a one-piece retainer.
27. If necessary, replace the sight-glasses and insulation (14).
28. Place one washer and one 1.888-inch spacer (15) on each stud. **NOTE:** There are three different sizes of spacers. Verify the size to ensure the correct spacers are installed.
29. Insert the front lower insulation (16) into the front lower insulation retainer(s) (17) and install assembly on frypot. Secure with ¼”-20 washer-nuts. If frypot uses two retainers, connect them together with two ¼” self-tapping screws. **NOTE:** Full-vat units have a two-piece insulation retainer and two pieces of insulation. Dual-vat units have one-piece components.
30. Return to the rear of the frypot and fully tighten all washer-nuts.
31. Remove and replace the plenum gaskets (18).
32. Place a 0.938-inch spacer (19) on the plenum-mounting studs, and mount the plenum (20). Ensure the gaskets are clear of the burner tubes by pulling the plenum back slightly. Place a washer on each stud and secure plenum with ¼”-20 lock-nuts.
33. Install the upper oil-zone insulation (21) by pressing it under the upper combustion chamber metalwork. Secure the insulation with the bracket (22) and ¼” self-tapping screws.
34. Install the upper burner rail blanket insulation (23). Position any excess insulation toward the top of the frypot. Avoid overhang past the bottom of the upper burner rail. Overhang in this area will make future burner replacement more difficult.
35. Cover the insulation with the insulation retainer (24), and secure with ¼” self-tapping screws.
36. Reinstall probes, drain valves, high-limit thermostats, and other pipe fittings using Loctite® PST56765 sealant or equivalent on the threads.

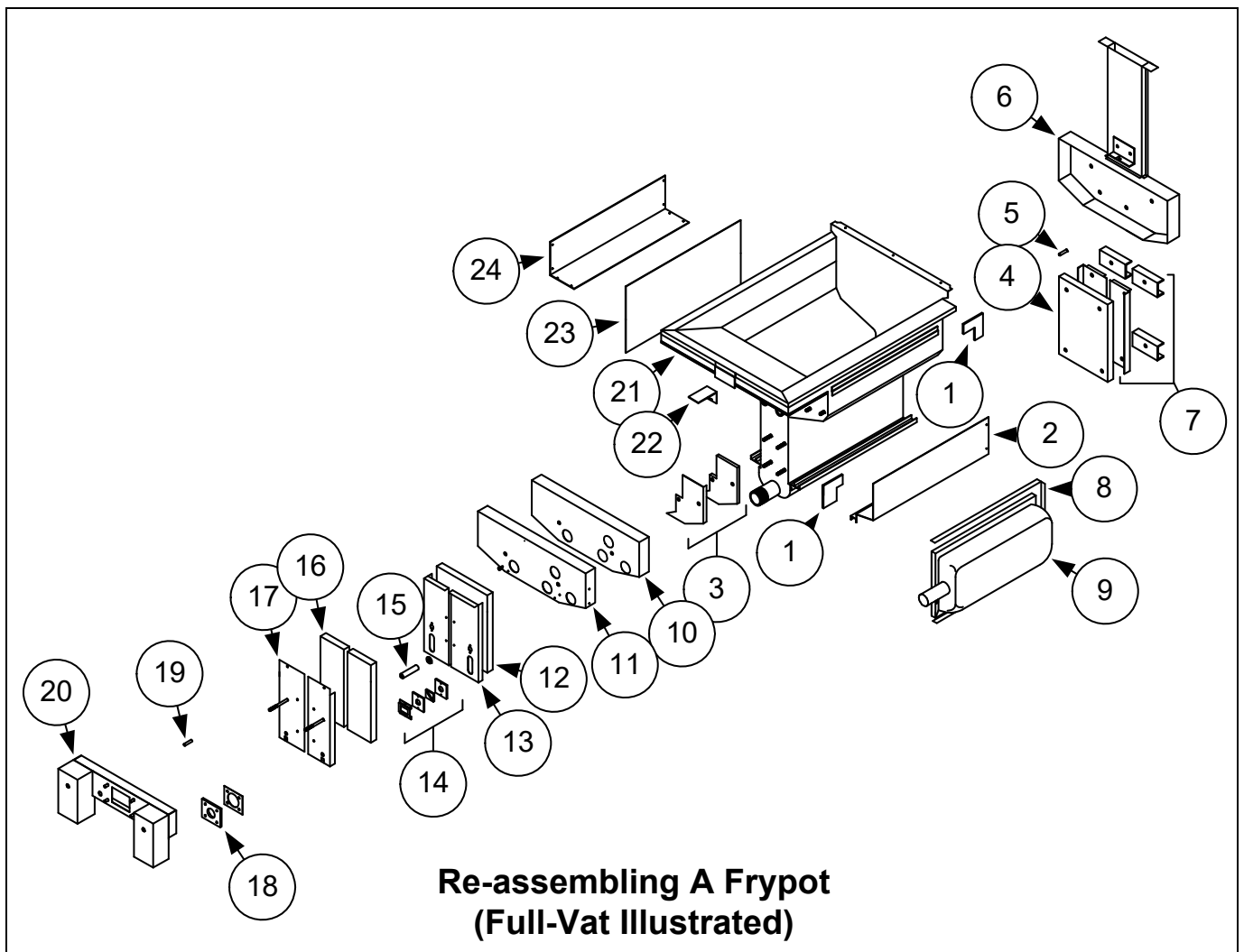

1.10 Troubleshooting and Problem Isolation

Because it is not feasible to attempt to include in this manual every conceivable problem or trouble condition that might be encountered, this section is intended to provide technicians with a general knowledge of the broad problem categories associated with this equipment, and the probable causes of each. With this knowledge, the technician should be able to isolate and correct any problem encountered.

Problems you are likely to encounter can be grouped into six categories:

1. Ignition failure
2. Improper burner function
3. Improper temperature control
4. Controller malfunctions
5. Filtration malfunctions
6. Leakage

The probable causes of each category are discussed in the following sections. A series of Troubleshooting Guides is also included at the end of the chapter to assist in solving some of the more common problems.

1.10.1 Heating (Ignition) Failure

Heating (ignition) failure occurs when the ignition module fails to sense a flame within the 4-second time delay period and locks out. When this happens, the module sends 24 VAC through the interface board alarm circuit to the controller.

M3000 controllers display “KHDWIQ J IDIOXUH.”

The three primary reasons for ignition failure, listed in order of probability, are problems related to:

1. Gas and/or electrical power supplies
2. Electronic circuits
3. Gas valve.

PROBLEMS RELATED TO THE GAS AND/OR ELECTRICAL POWER SUPPLIES

The main indicators of this are that an entire battery of fryers fails to light and/or there are no indicator lights illuminated on the fryer experiencing ignition failure. Verify that the quick disconnect fitting is properly connected, the fryer is plugged in with connector twisted and locked, the main gas supply valve is open, and the circuit breaker for the fryer electrical supply is not tripped.

PROBLEMS RELATED TO THE ELECTRONIC CIRCUITS

If gas and electrical power are being supplied to the fryer, the next most likely cause of ignition failure is a problem in the 24 VAC circuit. Verify that the drain valve is fully closed. The valve is attached to a microswitch that must be closed for power to reach the gas valve (often, although the valve handle appears to be in the closed position, the microswitch is still open). If the valve is fully closed, refer to Section 1.11.1, **TROUBLESHOOTING THE 24 VAC CIRCUIT**.

Some typical causes of heating failure in this category include a defective sensing wire in the ignitor assembly, a defective module, a defective ignition wire, and a defective ignitor.

Occasionally, a heating failure occurs in which all components appear to be serviceable and the microamp reading is within specification, but the unit nevertheless goes into ignition failure. The probable cause in this case is an intermittent failure of an ignition module. When the unit is opened up for troubleshooting, the module cools down enough to operate correctly; however, when the unit is again closed up and placed back into service the module heats up and fails.

PROBLEMS RELATED TO THE GAS VALVE

If the problem is not in the 24 VAC circuit, it is most likely in the gas valve, itself. Before replacing the gas valve, refer to Section 1.11.2 **TROUBLESHOOTING THE GAS VALVE**.

1.10.2 Improper Burner Function

With problems in this category, the burner ignites but exhibits abnormal characteristics such as “popping,” dark spots on the burner ceramics, fluctuating flame intensity, and flames shooting out of the flue.

“*Popping*” indicates delayed ignition. In this condition, the main gas valve is opening but the burner is not immediately lighting. When ignition does take place, the excess gas “explodes” into flame, rather than smoothly igniting.

The primary causes of popping are:

- Incorrect or fluctuating gas pressure
- Defective or incorrectly adjusted combustion air blower
- Inadequate make-up air
- Heat-damaged computer or ignition module
- Cracked ignitor or broken ignition wire
- Defective ignition module
- Cracked burner tile (typically causes a very loud pop).

If popping occurs only during peak operating hours, the problem may be incorrect or fluctuating gas pressure. Verify that the incoming gas pressure (pressure to the gas valve) is in accordance with the appropriate CE or Non-CE Standard found in Section 2.3 page 2-4 of the BIGL30 Series Gas Fryer Installation and Operation Manual, and that the pressure remains constant throughout all hours of usage. Refer to Section 1.7, **Checking the Burner Manifold Gas Pressure** in this manual for the procedure for checking the pressure of gas supplied to the burner.

If popping is consistent during all hours of operation, the most likely cause is an insufficient air supply. Check for “negative pressure” conditions in the kitchen area. If air is flowing into the kitchen area, this indicates that more air is being exhausted than is being replenished and the burners may be starved for air.

If the fryer’s gas and air supplies are correct, the problem is most likely with one of the electrical components. Examine the ignition module and controller for signs of melting, distortion, and/or discoloration due to excessive heat build-up in the fryer (this condition usually indicates improper flue performance). A melted or distorted ignition module is automatically suspect and should be replaced; however, unless the condition causing excessive heat is corrected, the problem is likely to recur.

Verify that the ignition wire is tightly connected at both ends and free of obvious signs of damage. Again, if damage is due to excessive heat in the fryer, that problem must also be corrected. Check for proper operation by disconnecting the wire from the ignitor (spark plug), inserting the tip of a screw driver into the terminal. With the insulated handle of the screwdriver, hold the shaft near the frame of the fryer as the power switch is placed in the ON position. A strong, blue spark should be generated for at least four seconds.



Make sure you are holding the insulated handle of the screwdriver and not the blade. The sparking charge is approximately 25,000 volts.

Examine the ignitor (spark plug) for any signs of cracking. A cracked ignitor must be replaced.

If all other causes have been ruled out, examine the burner tiles for any signs of cracking. If cracking is found, the burner must be replaced.

Fluctuating flame intensity is normally caused by either improper or fluctuating incoming gas pressure, but may also be the result of variations in the kitchen atmosphere. Verify incoming gas pressure in the same way as for “popping,” discussed in the preceding paragraphs. Variations in the kitchen atmosphere are usually caused by air conditioning and/or ventilation units starting and stopping during the day. As they start and stop, the pressure in the kitchen may change from positive or neutral to negative, or vice versa. They may also cause changes in airflow patterns that may affect flame intensity.

Dark spots on the burner tiles are the result of an improper air/gas mixture. Adjust the combustion air blower to reduce the amount of air in the mixture to correct this problem

Flames shooting out of the flue are usually an indication of negative pressure in the kitchen. Air is being sucked out of the burner enclosure and the flames are literally following the air. If negative pressure is not the cause, check for high burner manifold gas pressure in accordance with the procedures in Section 1.7.

An **excessively noisy burner**, especially with **flames visible above the flue opening**, may indicate that the gas pressure is too high, or it may simply be that the gas valve vent tube is blocked. If the incoming gas pressure is correct and the vent tube is unobstructed, the gas valve regulator is probably defective.

Occasionally a burner may apparently be operating correctly, but nevertheless the fryer has a **slow recovery rate** (the length of time required for the fryer to increase the oil temperature from 250°F to 300°F (121°C to 149°C)). The primary causes of this include an over-filled frypot, a dirty or out-of-adjustment combustion air blower, low burner manifold pressure, and/or damaged burner tiles. Adding oil to the frypot during the recovery process will also cause a slow recovery rate.

If these causes are ruled out, the probable cause is a misadjusted gas valve regulator. Refer to Section 1.7, **Checking the Burner Manifold Gas Pressure**, for the gas valve adjustment procedure.

1.10.3 Improper Temperature Control

Temperature control, including the melt cycle, is a function of several interrelated components, each of which must operate correctly. The principle component is the temperature probe. Other components include the interface board, the controller itself, and the ignition module.

Improper temperature control problems can be categorized into melt cycle problems and failure to control at setpoint problems.

MELT CYCLE PROBLEMS

Initiation of the melt cycle with manual M3000 controllers is automatic. Problems may originate from the controller itself, the temperature probe, or a malfunctioning heat relay on the interface board.

FAILURE TO CONTROL AT SETPOINT

Problems in this category may be caused by the temperature probe, the interface board, or the controller.

1.10.4 Controller Malfunctions

RECOVERY TIME

Recovery time – is a method of measuring a fryer’s performance. Put simply, it is the time required for the fryer to increase the oil temperature from 250°F to 300°F (121°C to 149°C). This range is used as a standard since ambient kitchen temperatures can affect the test if lower ranges are used.

The controller performs the recovery test each time the fryer warms up. An operator can view the results of the test any time the fryer is above the 325°F (163°C) point by pressing the INFO button once when the fryer is on. The test results will be displayed in the controller’s LED panel in minutes and seconds. The maximum acceptable recovery time for BIGL30 series gas fryers is two minutes and twenty-five seconds (2:25).

1.10.5 Filtration Malfunctions

The majority of filtration problems arise from operator error. One of the most common errors is placing the filter pad on the bottom of the filter pan rather than over the filter screen.

Whenever the complaint is “the pump is running, but no oil is being filtered,” check the installation of the filter pad, including that the correct size is being used. While you are checking the filter paper/pad, verify that the O-rings on the filter pan suction tube are present and in good condition. Missing or worn O-rings will allow the pump to suck air and decrease its efficiency.

If the pump motor overheats, its thermal overload will trip and the motor will not start until it is reset. If the pump motor does not start, press the red reset switch located on the front of the motor. If the pump then starts, something caused the motor to overheat. It may be that several frypots in a large battery of fryers were being filtered one after the other and the pump became hot. Letting the pump cool down for at least a half-hour is all that is required in this case. More often, the pump overheated for one of the following reasons:

- Shortening that remained in the pan, after previous filtering, solidified in the suction tube recess in the bottom of the pan or the suction tube, itself. Adding hot oil to the pan and waiting a few minutes will usually correct this problem. A flexible wire can be used to clean out the suction tube and the recess in the bottom of the pan. **NEVER** use compressed air to blow solidified shortening out of the suction tube!

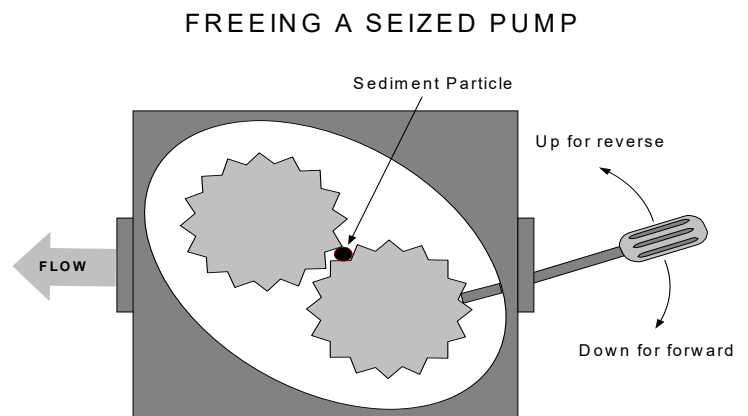

- Room temperature oil was filtered. Cold oil is thicker and causes the pump motor to work harder and overheat.

If the motor hums but the pump does not rotate, there is a blockage in the pump. Incorrectly sized or installed paper will allow food particles and sediment to pass through the filter pan and into the pump. When sediment enters the pump, the gears can bind up and cause the motor to overload, tripping the thermal overload. Solidified shortening in the pump will also cause it to seize, with similar results.

A pump seized by debris or hard shortening can usually be freed by manually moving the gears with a screwdriver or other instrument as illustrated on the previous page. **Make sure power to the pump motor is off before trying this.**

1. Disconnect power to the filter system.
 2. Remove the input plumbing from the pump.
 3. Use a screwdriver to manually turn the gears.
- Turning the pump gears backwards will release a hard particle and allow its removal.
 - Turning the pump gears forward will push softer objects and solid shortening through the pump and allow free movement of the gears.

Filter paper/pads that are installed incorrectly will also allow food particles and sediment to pass through and clog the suction tube recess on the bottom of the filter pan or the suction tube, itself. Particles large enough to block the suction tube recess or the suction tube may indicate that the crumb tray is not being used.

1.10.6 Leakage

Leakage of the frypot is usually due to improperly sealed high-limit thermostats, RTD's, temperature probes, and drain fittings. When installed or replaced, each of these components must be sealed with Loctite® PST56765 sealant or equivalent to prevent leakage. In very rare cases, a leak may develop along one of the welded edges of the frypot. When this occurs, the frypot must be replaced.

If the sides or ends of the frypot are coated with oil, the most likely cause is spillage over the top of the frypot rather than leakage.

The clamps on the rubber boots that hold the drain tube sections together may loosen over time as the tubes expand and contract with heating and cooling during use. Also, the boot itself may be damaged. If the section of drain tube connected to the drain valve is removed for any reason, ensure that its rubber and clamps are in good condition and properly fitted around the drain tube when it is reinstalled. Also, check to ensure that the drain tube runs downward from the drain along its whole length and has no low points where oil may accumulate.

1.11 Troubleshooting Guides

The troubleshooting guides on the following pages are intended to assist service technicians in isolating the probable causes of equipment malfunctions by following a logical, systematic process. An additional set of operator troubleshooting guides are contained in Chapter 7 of the BIGL30 Series Installation and Operation Manual. It is suggested that service technicians thoroughly familiarize themselves with both sets.

1.11.1 Troubleshooting the 24 VAC Circuit

Prior to checking for problems associated with the 24 VAC circuit, ensure that the unit is connected to a power supply, the drain valve is fully closed, and the controller is on and is calling for heat (green dot appears under heat indicator and display toggles between **OR Z W H P S**).

NOTE: All voltage measurements must be made within **4 seconds** of the unit calling for heat. If unit does not fire within **4 seconds**, ignition modules will lock out and controller must be turned off, then on to reset.

The following processes will assist you in troubleshooting the 24 VAC circuit and ruling it out as a probable cause:

- **24 VAC is not present on the interface board J3 pin 9 (LED 5 (GV)).**
 1. If LED 3 *is not* continually lit, the probable causes are a failed 24 VAC transformer or failed wiring between the transformer and interface board.
 2. If LED 3 *is* continually lit, check the right PWR terminal (LED 4) for 24 VAC. On dual units, also check the left PWR terminal (LED 2) for 24 VAC. Verify that the F2 fuse is not blown.
 - a. If 24 VAC *is not* present, the probable cause is a failed interface board, blown fuse or a defective heat relay.
 - b. If 24 VAC *is* present, check for 24 VAC on V1S (or V1D and V2D, if dual unit).
 - i. If 24 VAC *is not* present, check the fuses. If they are good, the probable causes are failed ignition module(s) or a failed interface board. Replace the questionable ignition module with one known to be good to isolate the cause.
 - ii. If 24 VAC *is* present, the probable cause is a failed interface board.
- **24 VAC is present on interface board J3 pin 9 (LED 5 (GV)) and, on dual units, on J1 pin 9 (LED 1 (GV)).**
 1. If 24 VAC *is not* present across the gas valve main coil (MV terminals), probable causes are an open high-limit thermostat or a failed wire between the interface board and gas valve. Be sure to check both valves on dual units.

Check continuity of high-limit thermostat. If reading is zero, problem is in wiring.
 2. If 24 VAC *is* present across the gas valve main coil (MV terminals), the 24 VAC circuit is working and the problem may be with the gas valve. Be sure to check both valves on dual vat units.
- **Ensure drain valve is closed and that it has continuity.** If reading is zero, problem is in wiring.

24 VOLT CIRCUIT
 With Interface Board 106-6706 and
 Two 807-1006 (FV) Ignition Modules
 Single Spark Module

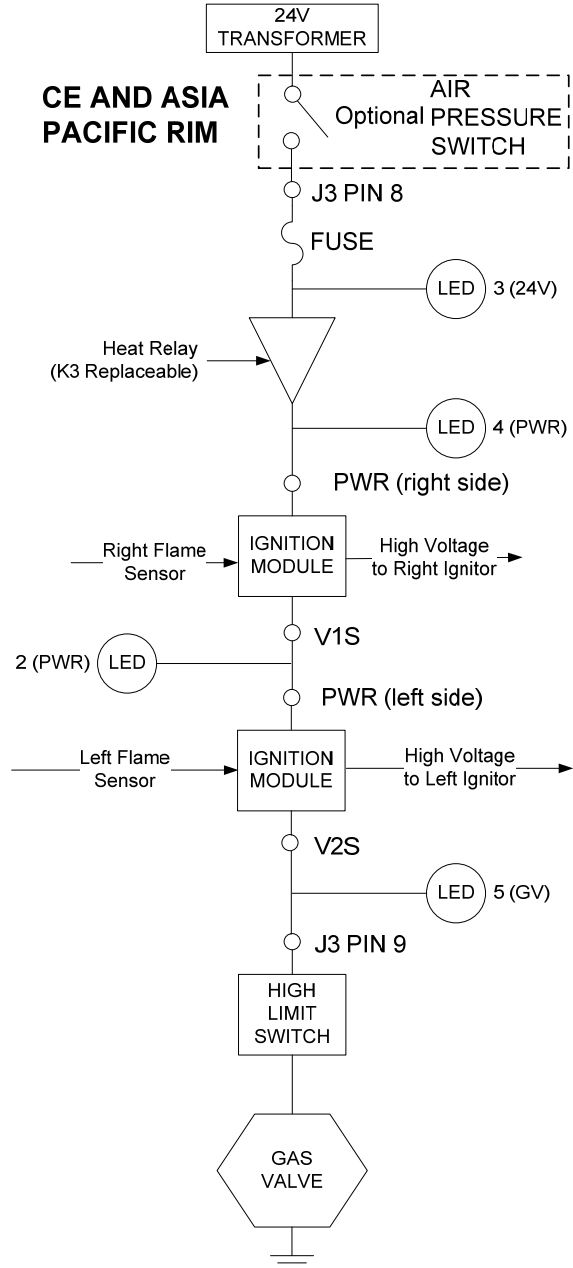

24 VOLT CIRCUIT
 With Interface Board 106-6706 and
 One 807-3366 (FV) Ignition Module
 Dual Spark Module

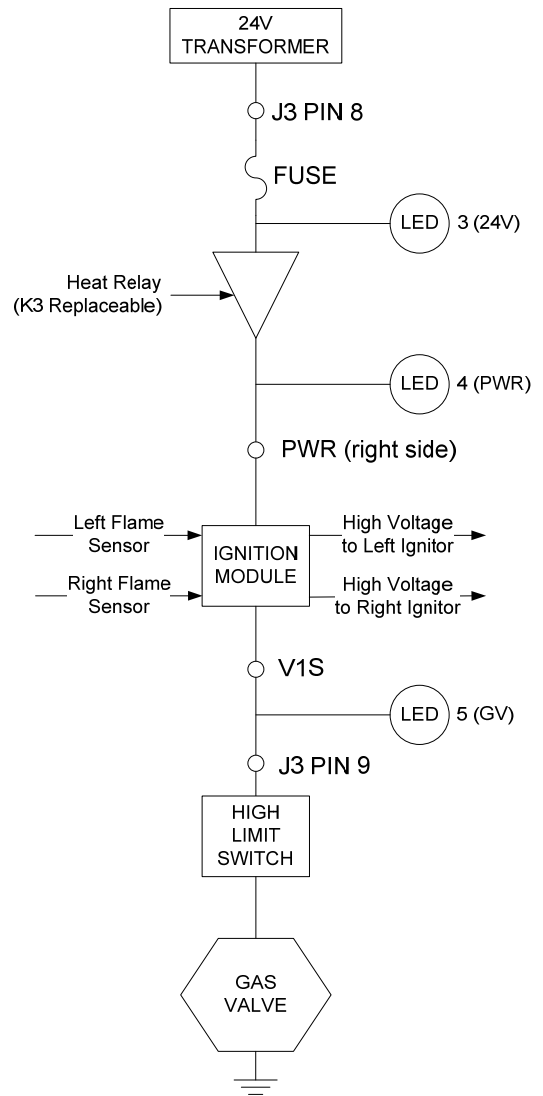

24 VOLT CIRCUIT
 With Interface Board 106-6706 and
 Two 807-3365 (DV) Ignition Modules

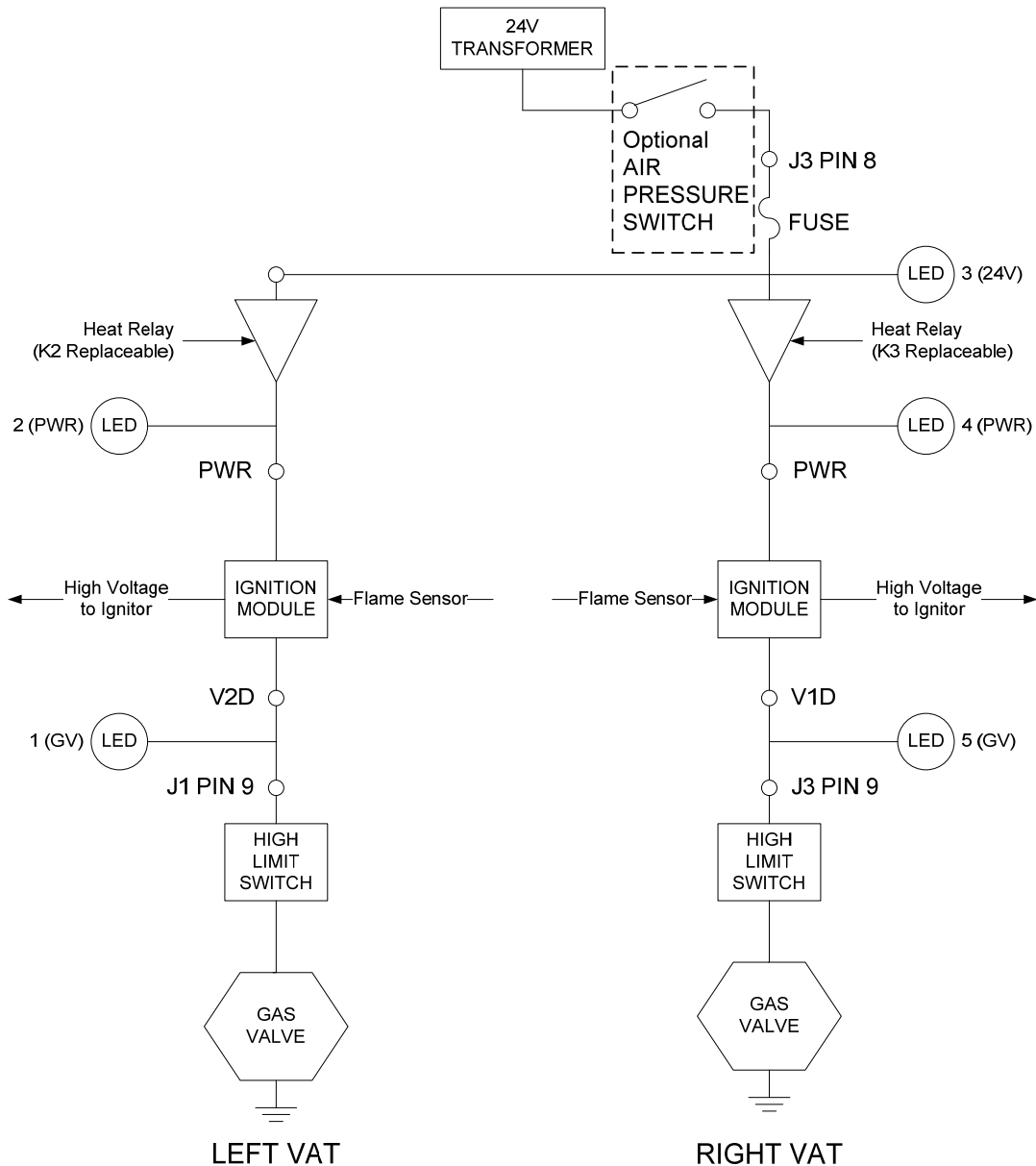

1.11.2 Troubleshooting the Gas Valve

Prior to checking for problems associated with the gas valve, ensure that the unit is calling for heat. Also, for non-CE units, verify that the gas valve is in the ON position.

The following processes will assist you in troubleshooting the gas valve and ruling it out as a probable cause:

- If 24 VAC is not present across gas valve main coil, the probable cause is the 24 VAC circuit. Refer to the 24 VAC circuit troubleshooting guide.
- If 24 VAC is present across gas valve main coil, check the incoming gas pressure and compare to the tables on page 2-4 of the Installation and Operation manual.

1. If incoming gas pressure *is not* correct, the probable cause is the gas supply to fryer.
2. If incoming gas pressure *is* correct, check the burner manifold gas pressure and compare it to the tables on page 2-7 of the Installation and Operation manual.
 - a. If burner manifold gas pressure *is not* correct, the probable cause is an improperly adjusted or failed gas valve. Adjust the valve by following the procedure “Check Burner Manifold Pressure” in Section 1.7 of this manual. If the valve cannot be adjusted, replace it.
 - b. If outgoing gas pressure *is* correct, the gas valve is okay.

1.11.3 Troubleshooting the Temperature Probe

⚠ CAUTION

Disconnect the controller before testing temperature probe resistances to avoid invalid readings

Prior to checking for problems associated with the temperature probe, inspect the probe body for damage while it is still in the frypot. Remove and replace the probe if it is bent, dented, or cracked. Also, inspect leads for fraying, burning, breaks, and/or kinks. If found, replace the probe.

The following processes will assist you in troubleshooting the temperature probe and ruling it out as a probable cause:

Before testing the probe, determine the temperature of the cooking oil using another thermometer or pyrometer placed at the tip of the questionable probe.

- If resistance through J3 pins 2 and 6 (J1 pins 2 and 6 for left side of dual unit) **is not** approximately equal to that given in the Probe Resistance Chart for the corresponding temperature, the probe has failed and must be replaced.
- If resistance through J3 pins 2 and 6 (J1 pins 2 and 6 for left side of dual unit) **is** approximately equal to that given in the Probe Resistance Chart for the corresponding temperature, measure the resistance through each of the previously tested pins to ground.
 1. If resistance *is not* 5 mega-Ohms or greater in each pin, the probe has failed and must be replaced.
 2. If resistance *is* 5 mega-Ohms or greater in each pin, the probe is okay.

1.11.4 Replacing the Transformer, Reset Switch or Filter Relay

Disconnect the fryer from the electrical power supply. Remove the cover from the transformer box in the rear of the fryer to expose the interior of the transformer box. Replace the transformer or filter relay marking the wires to ease reassembly. Once replaced, reconnect the power. When replacing a filter relay in the transformer, ensure the 24VAC relay (8070012) is used.

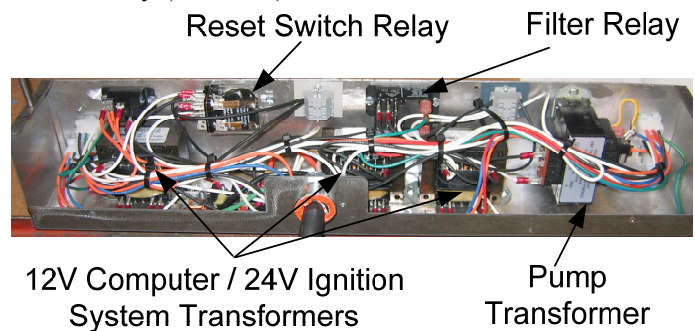

1.12 Probe Resistance Chart

<h3 style="text-align: center;">Probe Resistance Chart</h3> <p style="text-align: center;"><i>For use with B IGL30 Series fryers manufactured with Minco Thermistor probes only.</i></p>														
F	OHMS	C	F	OHMS	C	F	OHMS	C	F	OHMS	C	F	OHMS	C
60	1059	16	130	1204	54	200	1350	93	270	1493	132	340	1634	171
65	1070	18	135	1216	57	205	1361	96	275	1503	135	345	1644	174
70	1080	21	140	1226	60	210	1371	99	280	1514	138	350	1654	177
75	1091	24	145	1237	63	215	1381	102	285	1524	141	355	1664	179
80	1101	27	150	1247	66	220	1391	104	290	1534	143	360	1674	182
85	1112	29	155	1258	68	225	1402	107	295	1544	146	365	1684	185
90	1122	32	160	1268	71	230	1412	110	300	1554	149	370	1694	188
95	1133	35	165	1278	74	235	1422	113	305	1564	152	375	1704	191
100	1143	38	170	1289	77	240	1432	116	310	1574	154	380	1714	193
105	1154	41	175	1299	79	245	1442	118	315	1584	157	385	1724	196
110	1164	43	180	1309	82	250	1453	121	320	1594	160	390	1734	199
115	1174	46	185	1320	85	255	1463	124	325	1604	163	395	1744	202
120	1185	49	190	1330	88	260	1473	127	330	1614	166	400	1754	204
125	1195	52	195	1340	91	265	1483	129	335	1624	168	405	1764	207

1.13.6 Control Power Reset Switch

The control power reset switch, is a momentary rocker switch located below the left control box (see Figures 6), that resets all power to all the controllers and boards in the fryer. It is necessary to reset all power after replacing any controller or board. Press and hold the switch for at least ten seconds when resetting the control power to ensure power has sufficiently drained from boards.

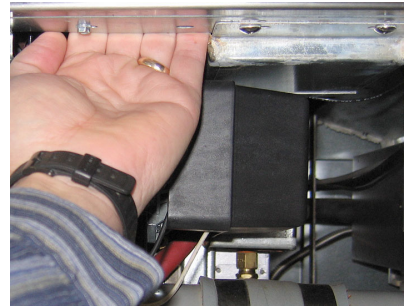

Figure 6

1.14 Controller Service Procedures

1.14.1 Controller Troubleshooting

Problem	Probable Causes	Corrective Action
<p>No Display on Controller.</p>	<p>A. No power to the fryer. B. Power switch turned off. C. Loose fuse holder. D. Controller has failed. E. Damaged controller wiring harness. F. Power supply component or interface board has failed.</p>	<p>A. Verify controller power cord is plugged in and that circuit breaker is not tripped. B. Some fryers have a rocker power switch inside the cabinet below the controller. Ensure the switch is turned on. C. Ensure fuse holder is screwed in properly. D. Swap the controller with a controller known to be good. If controller functions, replace the controller. E. Swap with a harness known to be good. If controller functions, replace the harness. F. If any component in the power supply system (including the transformer and interface board) fail, power will not be supplied to the controller and it will not function.</p>
<p>M3000 display shows i lowhu exv .</p>	<p>A. Another filtration cycle is still in process.</p>	<p>A. Wait until the previous filtration cycle ends to start another filtration cycle. This may take up to one minute. If filter busy is still displayed with no activity, remove and restore ALL power to the fryer.</p>
<p>M3000 display shows UHFRYHU\ IDXOW2</p>	<p>Recovery time exceeded maximum time limit for two or more cycles.</p>	<p>Silence the alarm by pressing the ✓ button. Check that fryer is heating properly. Maximum recovery for electric is 1:40.</p>
<p>M3000 display is in wrong temperature scale (Fahrenheit or Celsius).</p>	<p>Incorrect display option programmed.</p>	<p>Fryers using the M3000 controller can toggle between F° to C° by pressing and holding the ◀ and ▶ simultaneously for TEN seconds; three chirps sound. The computer displays WHFK PRGH2 Enter 1658. The controller displays R I I. Turn the controller on to check temperature. If the desired scale is not displayed, repeat.</p>

Problem	Probable Causes	Corrective Action
M3000 displays VHUYIFH UHTXIUHG followed by the error2	An error has occurred.	Press YES to silence alarm. The error is displayed three times. See list of issues in section 1.14.3. Fix issue. The computer displays V \ VWHP HUURU IL[HGC \ HV3QR2 Press YES. Computer displays HQWHU FRGH. Enter 1111 to clear error code. Pressing NO will allow the fryer to cook but the error will be redisplayed every 15 minutes.
M3000 display shows k r w l k 115.	Frypot temperature is more than 410°F (210°C) or, in CE countries, 395°F (202°C).	This is an indication of a malfunction in the temperature control circuitry, including a failure of the high-limit thermostat.
M3000 display shows K L I O I P I W 2	Controller in high-limit test mode.	This is displayed only during a test of the high-limit circuit and indicates that the high-limit has opened properly.
Controller displays OR z whps with an alarm.	Frypot temperature has dropped more than 40°F (17°C) for M3000 controllers below setpoint in idle mode or 45°F (25°C) in cook mode.	This display is normal for a short while if a large batch of frozen product is added to the frypot or if the fryer is not heating properly.
M3000 display shows or z whps, heating indicator cycles on and off normally but fryer does not heat.	A. Failed controller. B. Damaged controller wiring harness.	A. Replace controller. B. Replace controller wiring harness.
M3000 display shows WHPS SUREH I D I O X U H 2	Problem with the temperature measuring circuitry including the probe.	This indicates a problem within the temperature probe circuitry. Check resistance of probe, if faulty replace probe.
M3000 display shows SUREH I D I O X U H with alarm sounding.	Damaged controller wiring harness or connector.	Swap the controller wiring harness with one known to be good. If problem is corrected replace harness.
Controller will not go into program mode or some buttons do not actuate.	Failed controller.	Replace controller
M3000 display shows K L 6 E D G 2	Controller in high-limit test mode.	This is displayed only during a test of the high-limit circuit and indicates that the high-limit has failed.
M3000 display shows K H D W I Q J I D I O X U H with alarm sounding. Heating indicator is on, but fryer is not heating.	Failed controller, failed interface board, open high limit thermostat, gas valve or gas is turned off.	Check high limit thermostat, interface board, controller, gas valve. Ensure the gas valve is on.

Problem	Probable Causes	Corrective Action
M3000 display shows KHDWIQ J IDIOXUH and alarm sounds, but fryer operates normally (false alarm).	Failed controller.	Replace controller.
M3000 display shows FORVH GUDIQ YDOYH2	Drain valve is open or switch is out of adjustment or failed.	Ensure all drain valves are completely closed and that microswitches are adjusted and working.
M3000 display shows HUURU UP VGFUG	Defective SD Card. Shown only during software updates.	Replace card with another card.
M3000 display shows FDOO WHFK	Typically shown during software update. Also may be that parameter data has been corrupted or lost.	Press the FILTER button to bypass and continue.

1.14.2 M3000 Controller Useful Codes

To enter any of the following codes: Press and hold ◀ and ▶ simultaneously for **TEN** seconds; three chirps sound. The computer displays **WHFK PRGH2** Enter the codes below to perform the function.

- **5 : 9 <** – **Change from F° to C°** The computer displays **r i i**. Turn the computer on and check temperature to see the temperature scale. If the desired scale is not displayed, repeat.
- **7 7 6 6** – **Reset Factory Menu** The computer displays **FRPSOHWH** and then **r i i**. (**NOTE:** This will delete any hand-entered menu items).
- **5 : 9 4** – **Enter Tech Mode**. See page 1-36 to reset passwords and change filter pad time.
- **5 6 5 6** – **Switch between Domestic Menu and International Menu2** The computer displays **FRPSOHWH** and then **r i i**. (**NOTE:** This will delete any hand-entered menu items).
- **4 8 : =** – **Reset ILOWHU VWDW GDWD**
- **5 4 4 4** – **Reset FDOO WHFK Message** - Disconnect board locator plug (J3). Reinsert plug. Enter **5 4 4 4 2** Computer display switches to **r i i**. Remove and then restore power to the computer using the 20-pin plug.
- **= = < <** – **Reset EDGFUF Message** - Disconnect board locator plug (J3). Reinsert plug. Enter **= = < < 2** Computer display switches to **r i i**. Remove and then restore power to the computer using the 20-pin plug.

The following codes are entered when prompted to do so or from an energy misconfigured exception error.

- **5 5 5 5** – **Reset VHUYIFH UHTXIUHG Message** – Enter when the issue is fixed and prompted to enter.
- **5 6 7 8** – Enter **VHWXS PRGH** (This usually can be done without pressing the filter buttons if an error is displayed.)

PASSWORDS

To enter level one, level two passwords: Press and hold the **TEMP** and **INFO** buttons simultaneously until level 1 or level 2 is displayed. Release the buttons and **HQWHU Frgh** appears.

- **5 6 7 8** – **Fryer Setup, Level One and Level Two**
- **8 7 6 5** – **Usage Password** (resets usage statistics).

1.14.3 Service Required Errors

A SERVICE REQUIRED error alternating with YES displays on the computer. After YES is pressed the alarm is silenced. The computer displays an error message from the list below three times with the location of the error. Then the computer displays SYSTEM ERROR FIXED? YES/NO. If yes is chosen, enter code 1111. If NO is chosen the system returns to cook mode for 15 minutes then redisplay error until issue is fixed.

1.14.4 Error Log Codes

Code	ERROR MESSAGE	EXPLANATION
E03	ERROR TEMP PROBE FAILURE	TEMP Probe reading out of range
E04	HI 2 BAD	High limit reading is out of range.
E05	HOT HI 1	High limit temperature is past 410°F (210°C), or in CE countries, 395°F (202°C)
E06	HEATING FAILURE	A component has failed in the high limit circuit such as controller, interface board, contactor, gas valve, failure to light, open-high limit or gas is off.
E08	ERROR ATO BOARD	ATO board connection lost; ATO board failure
E17	ERROR ATO PROBE	ATO RTD reading out of range
E20	INVALID CODE LOCATION	SD card removed during update
E21	FILTER PAPER PROCEDURE ERROR (Change Filter Paper)	25-hour or customer-set timer has expired and the user has pressed "NO" twice at the "CHANGE FILTER PAPER" prompt.
E22	OIL IN PAN ERROR	Oil may be present in the filter pan.
E25	RECOVERY FAULT	Recovery time exceeded maximum time limit. Recovery time should not exceed 1:40 for electric.
E27	LOW TEMP ALARM	Oil temperature has dropped 40°F (17°C) below setpoint temperature in idle mode or 45°F (25°C) in cook mode. (This message may appear if a product is dropped and the start cook button is not pressed immediately or if too large of cook loads are dropped.)

1.14.5 M3000 Controller Menu Summary Tree

Reflected below are the major programming sections in the M3000 and the order in which submenu headings will be found under the sections in the Installation and Operation Manual.

Adding New Product Menu Items See section 2.10.2 in the M3000 Controller manual

Filter Menu	2.11
[Press and hold ◀ FLTR or FLTR ▶]	
Quick Filter	
Maint Filter	
Dispose	
Drain to Pan	
Fill Vat from Drain Pan	
Programming	
Level 1 Program	2.12
[Press and hold TEMP and INFO buttons, 2 beeps, displays Level 1, enter 1234]	
Product Selection	2.10.2
Name	
Cook Time	
Temp	
Cook ID	
Duty Time 1	
Duty Time 2	
Qual Tmr	
AIF Disable	
Assign Btn	
AIF Clock (Suppress Filter Prompt).....	2.12.1
Disabled	
Enabled	
Deep Clean Mode	2.12.2
High-Limit Test	2.12.3
Fryer Setup	2.9
Level 2 Program (Manager Level)	2.13
[Press and hold TEMP and INFO buttons, 3 beeps, displays Level 2, enter 1234]	
Prod Comp Sensitivity for product	2.13.1
E-Log Log of last 10 error codes.....	2.13.2
Password Setup Change passwords.....	2.13.3
Setup [enter 1234]	
Usage [enter 4321]	
Level 1 [enter 1234]	
Level 2 [enter 1234]	
Alert Tone Volume and Tone	2.13.4
Volume 1-9	
Tone 1-3	
Top Off After Sets number of cooks before top off prompt.....	2.13.5
Filter After Sets number of cooks before filter prompt.....	2.13.6
Filter Time Sets amount of time between filter cycles	2.13.7
Info Mode.....	2.14
[Press and hold INFO for 3 seconds, displays Info Mode]	
Full/Split Vat Configuration	
Filter Stats.....	2.14.1
Review Usage.....	2.14.2
Last Load	2.14.3

1.14.6 M3000 Controller Pin Positions and Harnesses

Connector	From/To	Harness PN	Pin #	Function	Voltage	Wire Color		
J2	Interface Board to Controller	8075165 SMT Controller to Interface Board Harness	1	12VAC In	12VAC	Orange		
			2	Ground				
			3	12VAC In	12VAC			
			4	FV Heat Demand				
			5	V Relay	12VDC			
			6	DV Heat Demand				
			7	R/H B/L	12VDC			
			8	Analog Ground				
			9	L/H B/L	12VDC			
			10	ALARM				
			11	Sound Device	5VDC			
			12	ALARM				
			13	FV Probe				
			14	Common Probes				
			15	DV Probe				
			16					
			17					
			18					
			19	Blower Relay	12VDC	Orange		
			20					
J3	Locator Harness Interface Board Ground to Controller	1080485	1	Vat #1		Black		
		1080486	2	Vat #2				
		1080487	3	Vat #3				
		1080488	4	Vat #4				
		1080489	5	Vat #5				
			6					
J4	Drain Switch	8075159 (FV) 8075160 (DV)	1	FV Drain		Black		
			2	FV Drain		Red		
			3	DV Drain		Black		
			4	DV Drain		Red		
J6	Previous M3000 J7 or Network Resistor	8074546 Controller Communication Harness	1	Ground		Black		
			2	CAN Lo		Red		
			3	CAN Hi		White		
			4					
			5					
			6					
J7	Next M3000 J6	8074646 Controller Communication Harness	1	Ground		Black		
			2	CAN Lo		Red		
			3	CAN Hi		White		
			4					
			5					
			6					

1.15 Loading and Updating Software Procedures

Updating the software takes approximately 30 minutes. The software only needs to be loaded in **ONE** controller, typically the far left controller in a battery and it will replicate to **all** the controllers and boards in the system. Press the TEMP button to check current M3000 software version. Remove the bezel by removing the screws under the bottom of the bezel. Remove the two screws securing the controller allow it to swing down. Remove the two screws on the left side cover plate of the M3000 controller or far left controller in a battery.

To update the software, follow these steps carefully:

Left Display	Right Display	Action
R I I	R I I	With the controller folded down, insert the SD card, with the contacts facing down and the notch on the bottom right (see Figure 7 and 8), into the slot on the left side of the M3000 controller. ENSURE THE CARD IS FULLY INSERTED INTO THE SD CARD SLOT.
X S J U D G H I Q S U R J U H V V	Z D I W	None required.
F F X S G D W I Q J	PERCENTAGE COMPLETE	None required.
ERR W	BLANK	None required.
F D O O	W H F K	If this message is displayed, press the FILTER button and the software load will continue.
X S J U D G H I Q S U R J U H V V	Z D I W	None required.
L I b F R R N K H [and L I b d W R K H]	PERCENTAGE COMPLETE	None required.
U H P R Y H V G F D U G	5 4 4	Remove the SD card using the fingernail slot on the top of the SD card.
F \ F O H S R Z H U .	BLANK	Cycle the control power using the hidden reset switch under the far left control box. ENSURE THE SWITCH IS HELD FOR 10 SECONDS.
ER D U G I G	Zero or a number from 1-4	Press the IO (Power) button.
V v w h p w s h	E L J O 7 4	Press the ▼ or ▲ to choose correct fryer type. BIGL30 (Frymaster)
V v w h p w s h	B I G L 3 0	Press ►. Ensure correct fryer type is displayed.
W \ S H	G L 3 0	Press the ▼ or ▲ to select proper fryer model. One of several fryer models may be displayed.
W \ S H	G L 3 0	Once proper fryer model is displayed, press ►.
H [I W	H [I W	Press the ✓ (check) button.
R I I	R I I	With the controller displaying R I I , VERIFY software update by pressing the TEMP button to check updated M3000 version on each controller. M3000 should display software version shown on SD card on all controllers .
R I I	R I I	Once the software has been updated and the versions are correct, replace the cover and screws covering the SD card slot. Replace the screws attaching the controller and replace the bezel and screws.
R I I	R I I	Using the menu on page 1-31, perform fryer setup under Level 1.



Figure 7

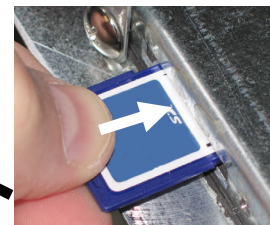
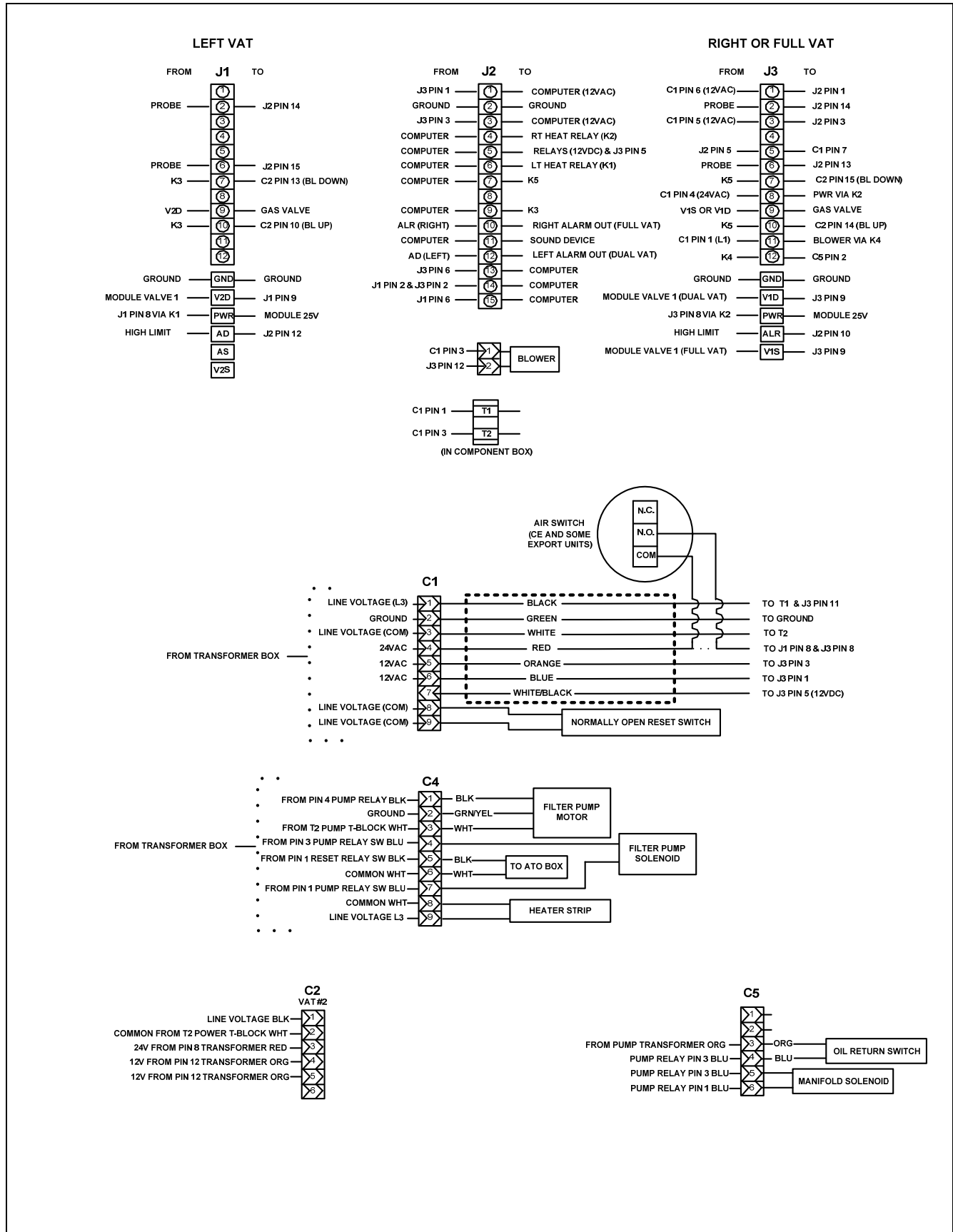
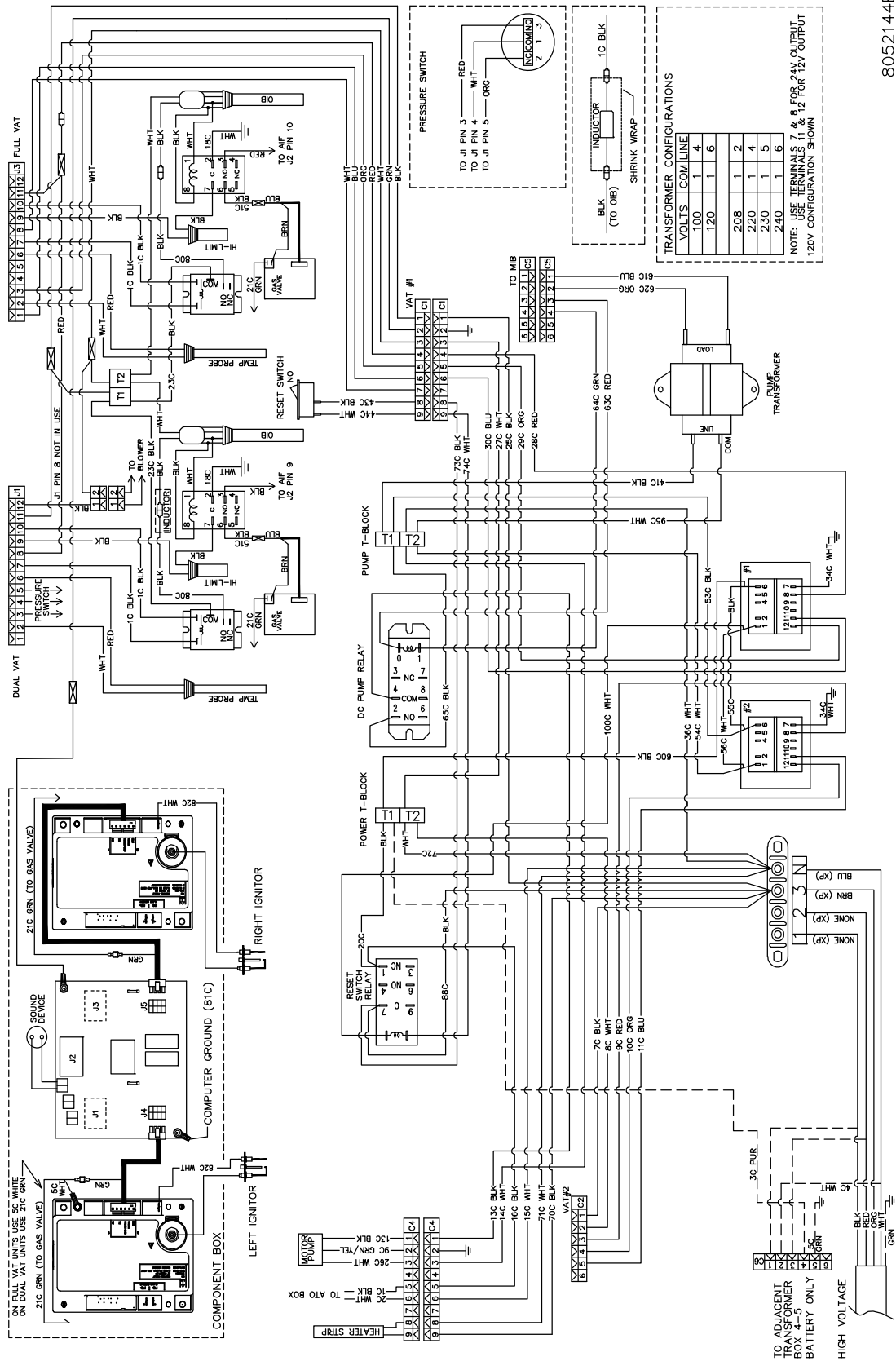

Figure 8

1.16 Principal Wiring Connections



1.17.1.2 BIGL230/430 CE Fenwal Module GIVEC Wiring



8052144B

1.17.2 BIGL330 Wiring

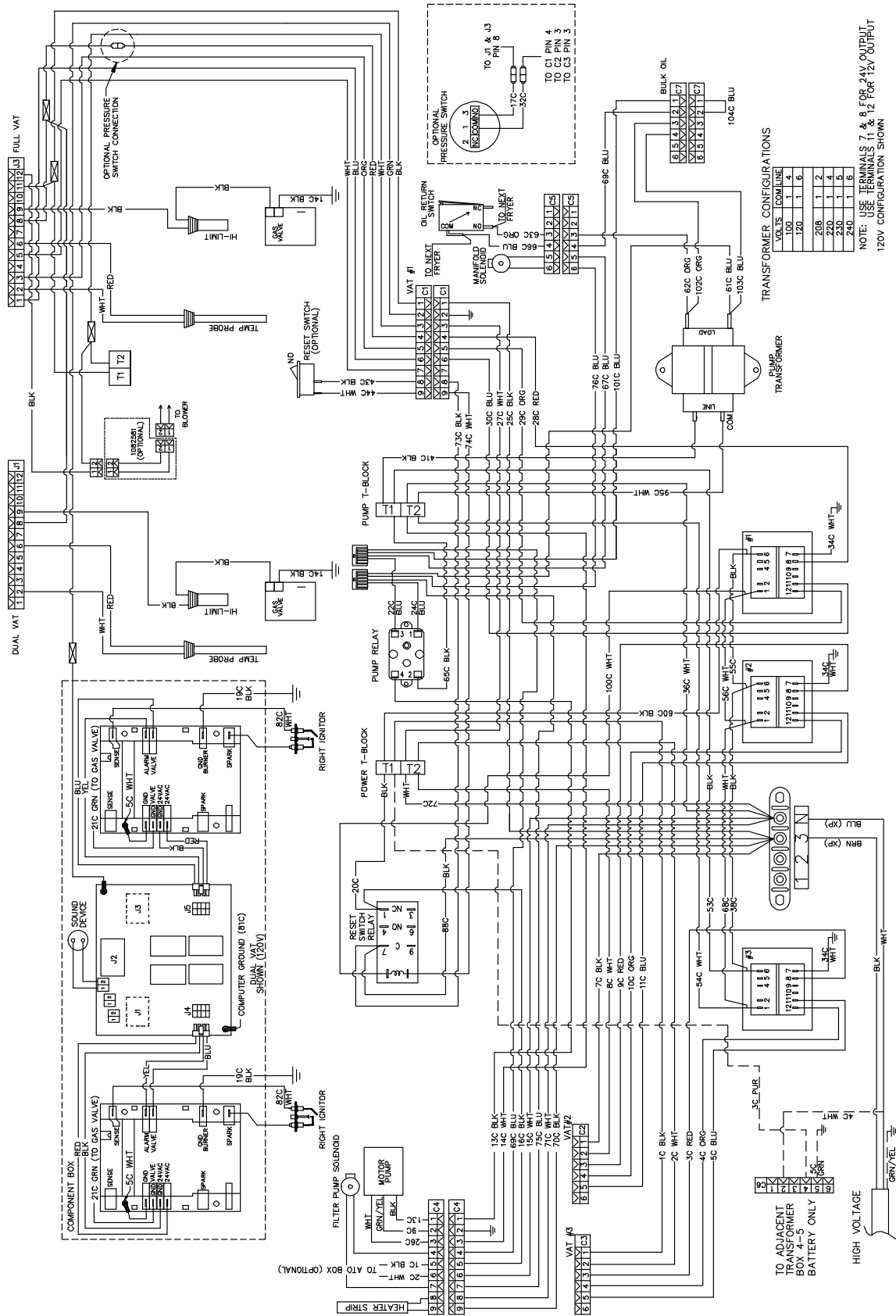

1.17.2.1 BIGL330 CE Fenwal Module GIVEC Wiring

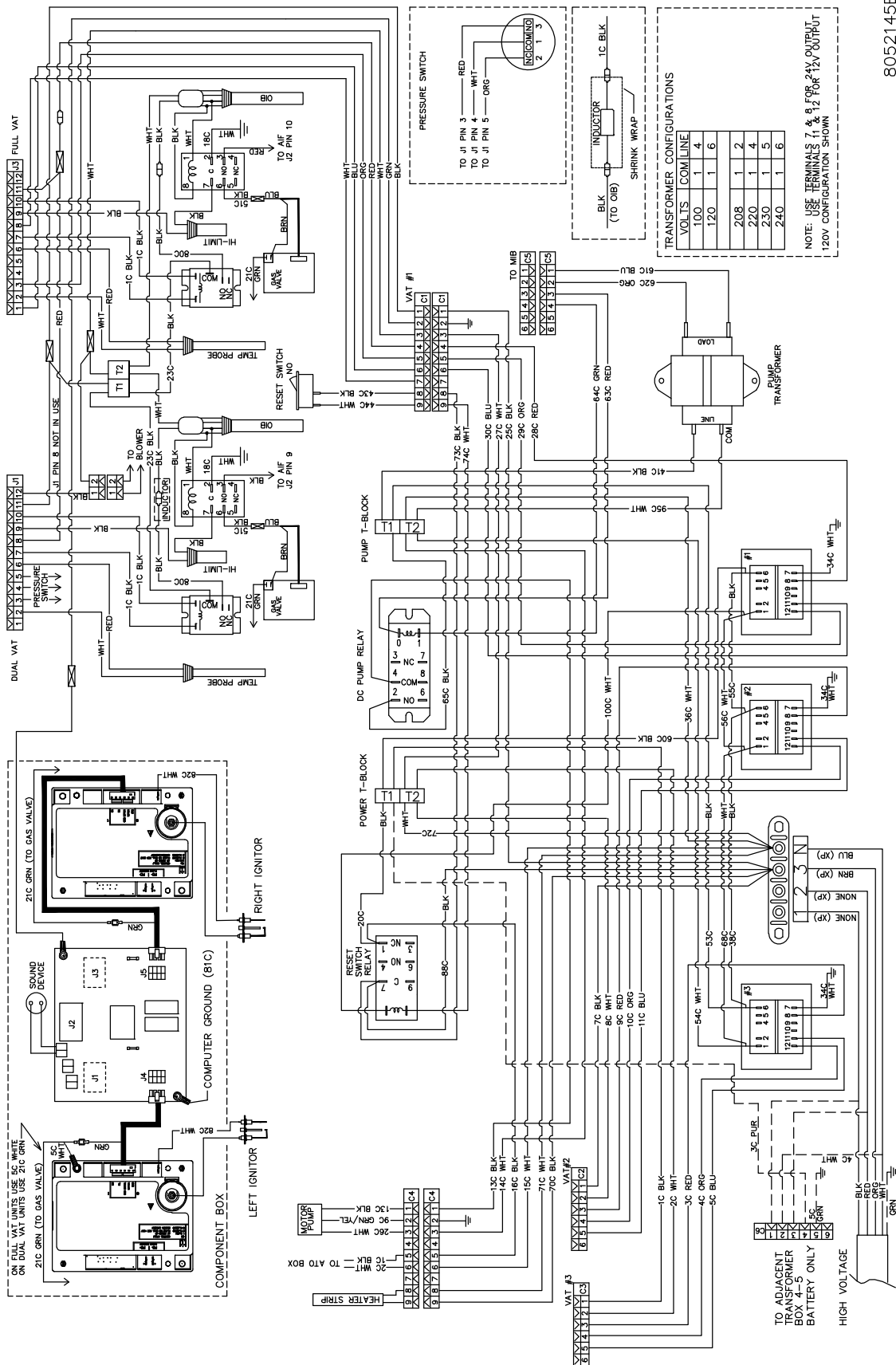

8052145B

1.17.3 BIGL430 Extra Transformer Box Wiring

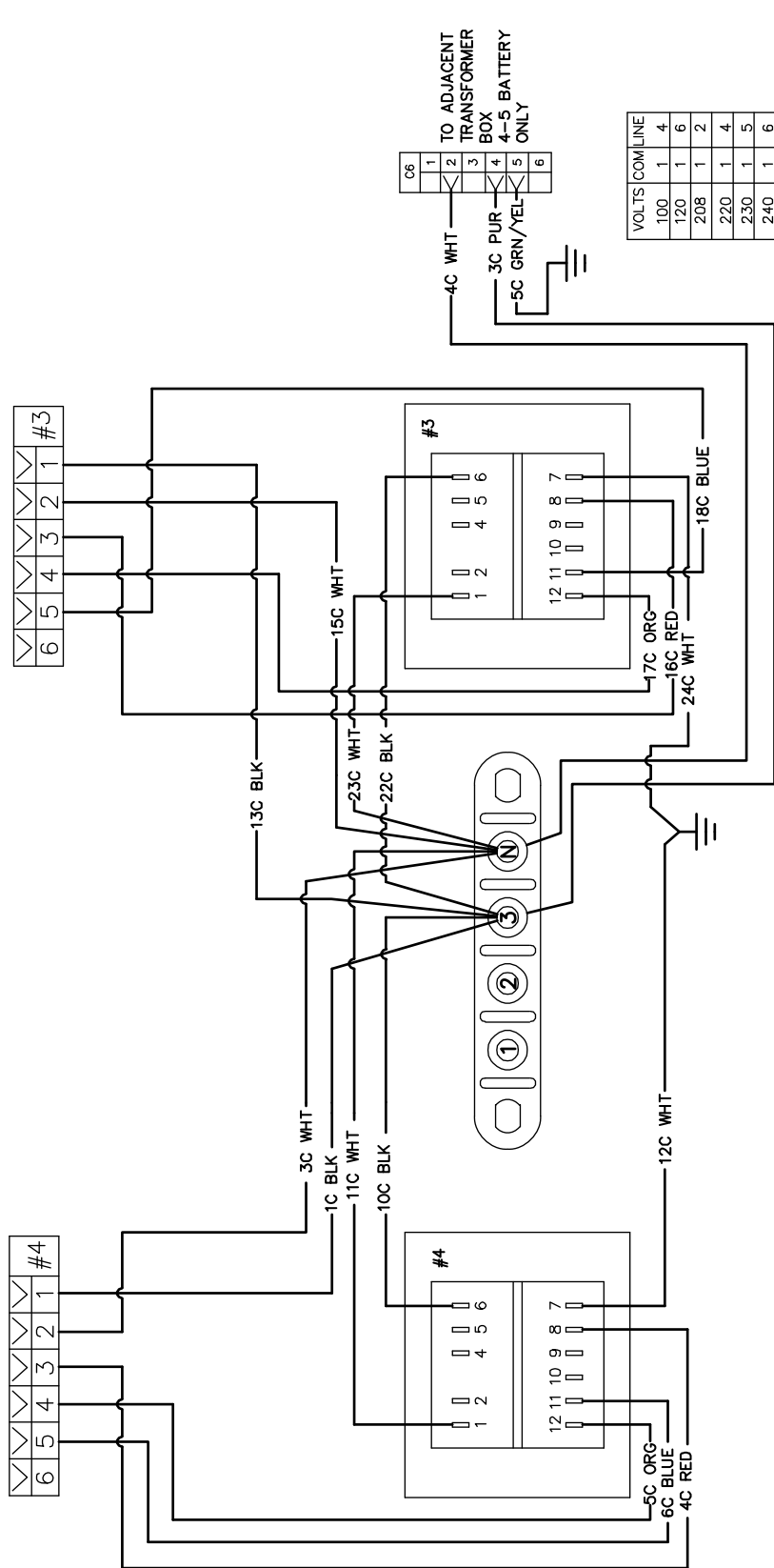

120V CONFIGURATION SHOWN
8051819A
 NOTE: USE TERMINALS 7 AND 8 FOR 24V OUTPUT.
 USE TERMINALS 11 AND 12 FOR 12V OUTPUT.

1.18.2 BIGL30 Series Dual Vat Single Spark Module

BIGL30 SERIES – DUAL VAT

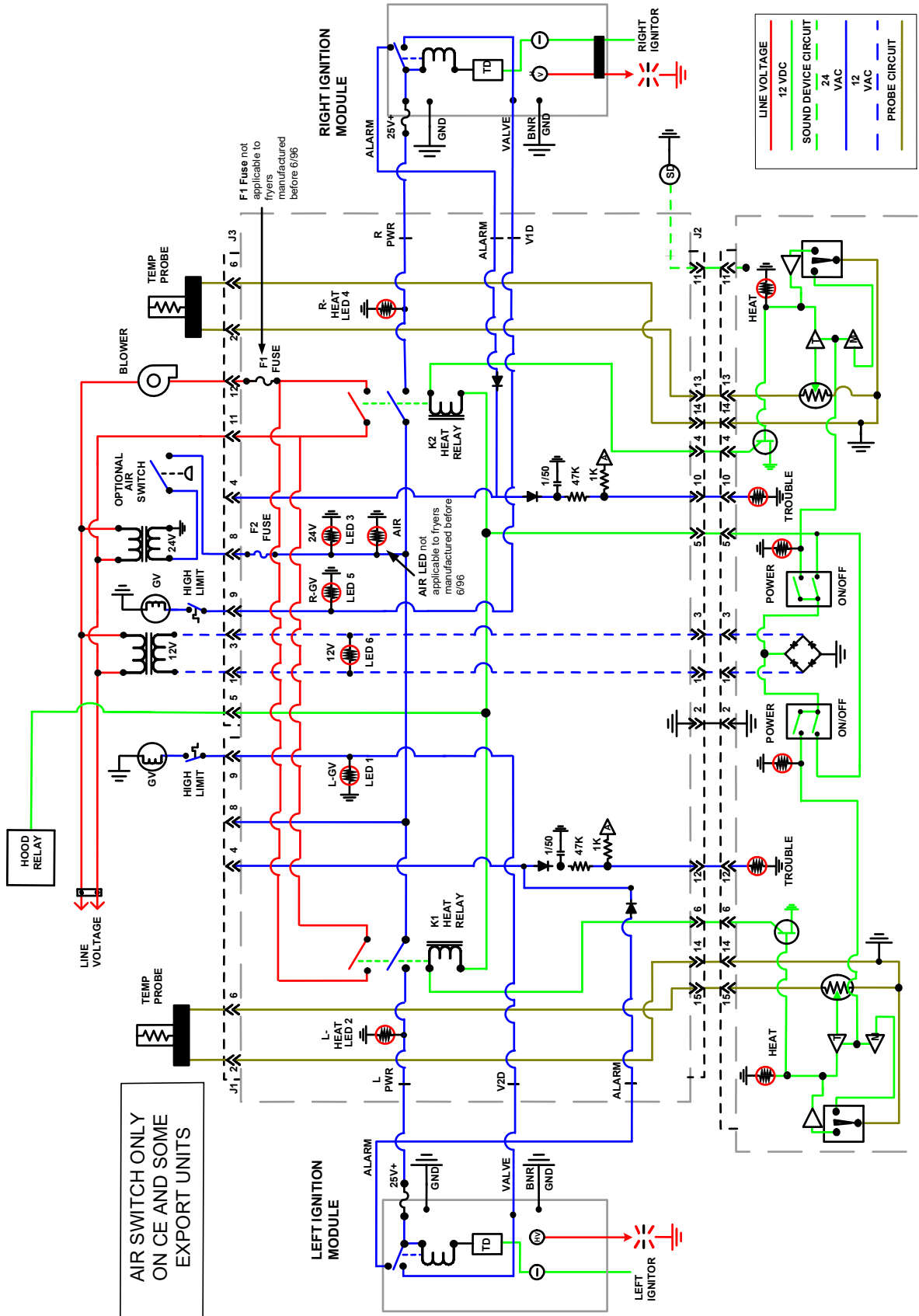

1.18.3 BIGL30 Series Data Network Flowchart

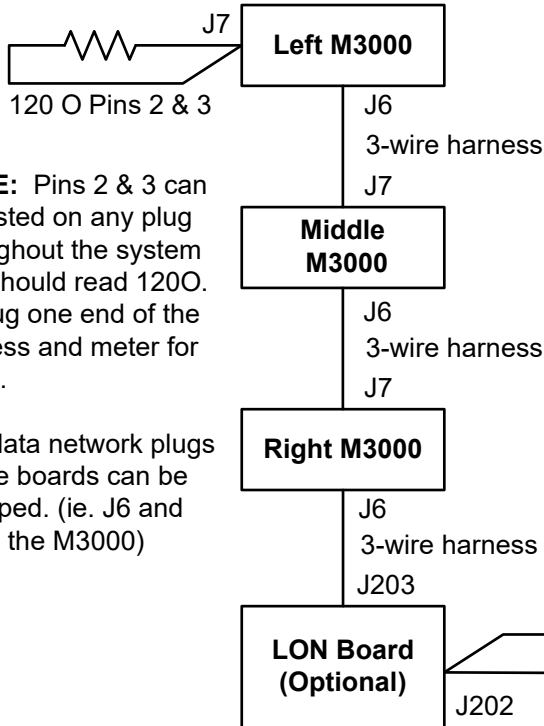

Harness	Pin #	Function	Voltage	Wire Color
3-wire harness	1	Ground		Black
	2	CAN Lo		Red
	3	CAN Hi		White
	4	NOT USED		
	5	NOT USED		
	6	NOT USED		

NOTE: Pins 2 & 3 can be tested on any plug throughout the system and should read 120Ω. Unplug one end of the harness and meter for 120Ω.

The data network plugs on the boards can be swapped. (ie. J6 and J7 on the M3000)

Turn each computer to OFF. Press the TEMP button on each computer and verify ALL software versions are present (M3000 and optional LON). A missing version may indicate an open connection.

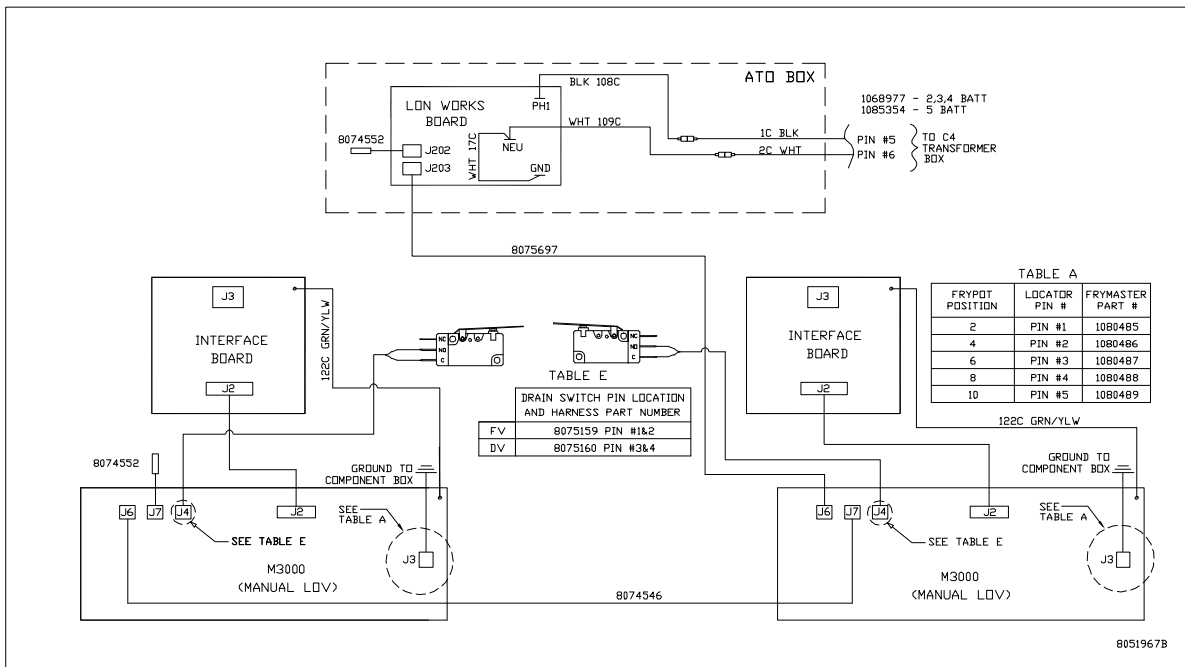

1.18.3 BIGL30 Series Data Network Flowchart without LON

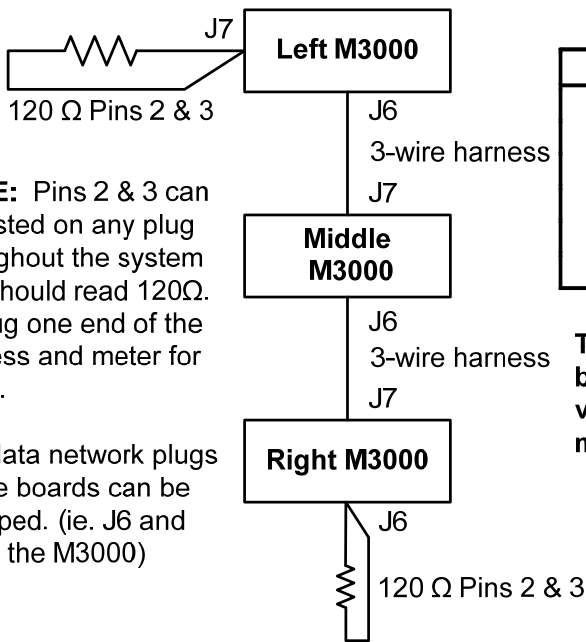

NOTE: Pins 2 & 3 can be tested on any plug throughout the system and should read 120Ω. Unplug one end of the harness and meter for 120Ω.

The data network plugs on the boards can be swapped. (ie. J6 and J7 on the M3000)

Harness	Pin #	Function	Voltage	Wire Color
3-wire harness	1	Ground		Black
	2	CAN Lo		Red
	3	CAN Hi		White
	4	NOT USED		
	5			
	6			

Turn each computer to OFF. Press the TEMP button on each computer and verify ALL software versions are present (M3000). A missing version may indicate an open connection.

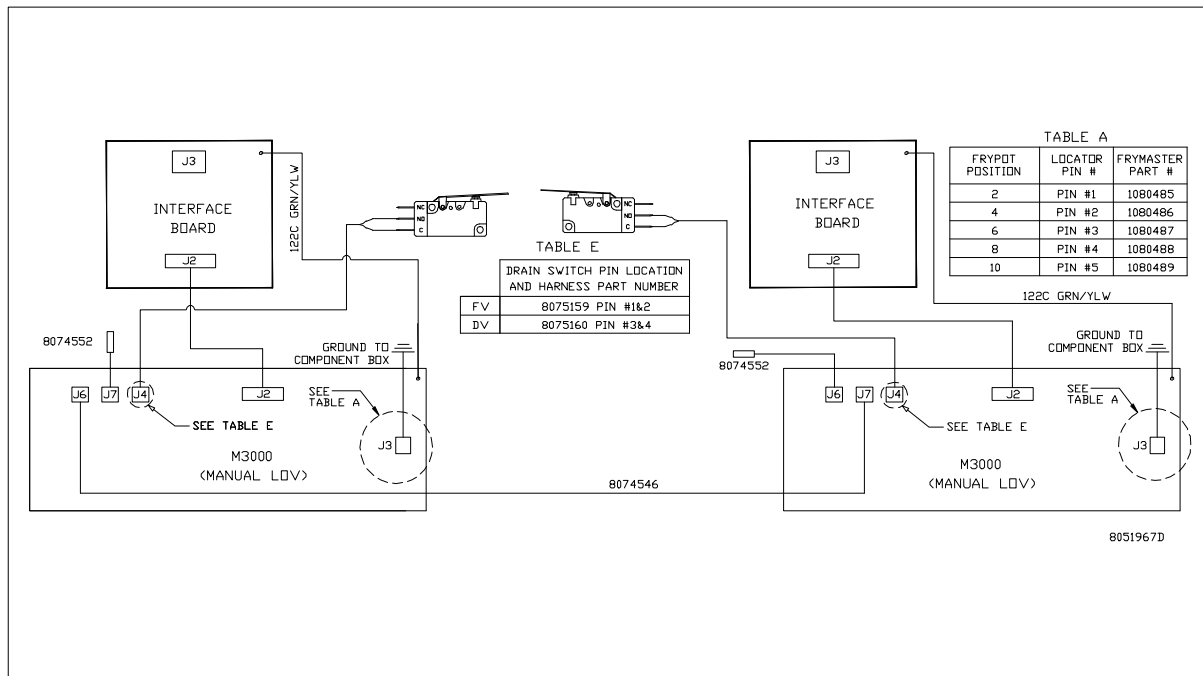

MANUAL LOV SERIES GAS FRYERS

CHAPTER 2: PARTS LIST

2.1 Accessories

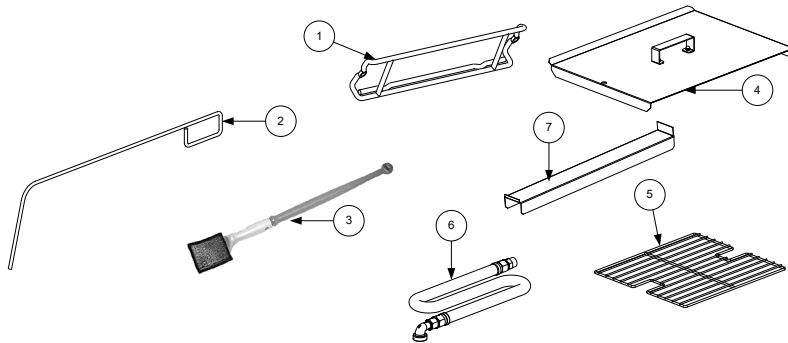

ITEM	PART #	COMPONENT
1	810-2793	Hanger, Basket
*	809-0171	Thumbscrew, ¼-20 X 1⅜-inch Universal Hood (<i>use 809-0921 for Spacer</i>)
*	809-0402	Thumbscrew, ¼ -20 X ½-inch Cap-N-Splash Hood
2	803-0197	Cleanout Rod, 27-inch
3	803-0430	Brush, Frypot Ecolab
4	106-8930	Cover, Full-Vat Frypot (<i>use 106-8931 for Dual-Vat Cover</i>)
*	826-0993SP	Handle Kit, Frypot Cover (includes handle and screws)
5	803-0375	Rack, Full-Vat Basket Support (<i>use 803-0372 for Dual-Vat Basket Support</i>)
6	810-0478	Gas Line, 1-Inch Dormont Flexible
7	108-6156	Connecting Strip, Frypot

* Not illustrated.

2.2 Doors, Sides, Flue Caps, Top Caps and Casters

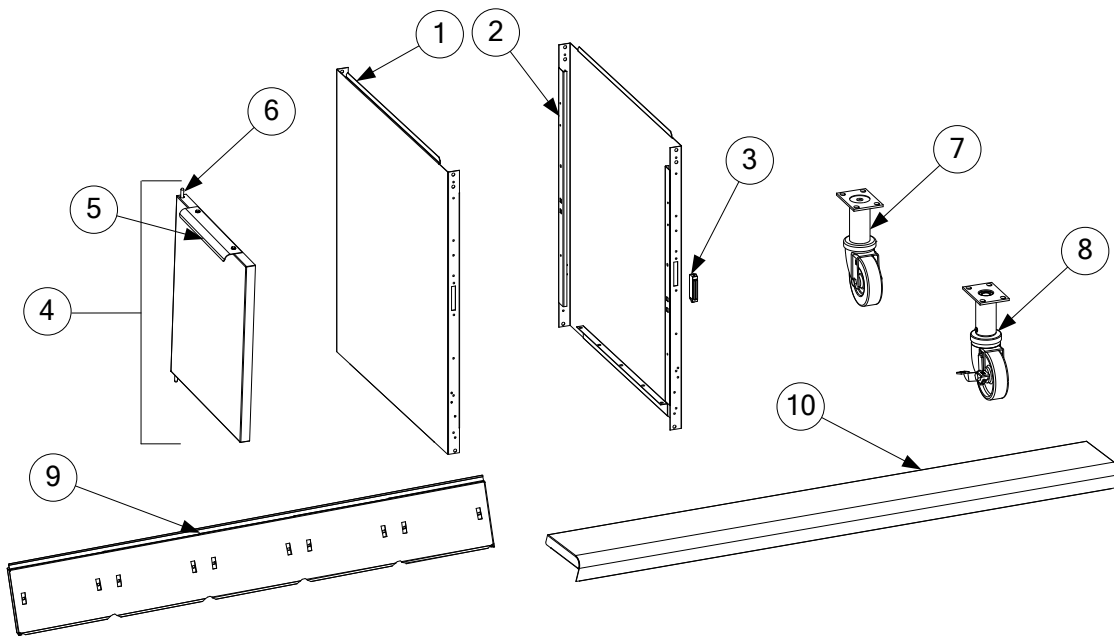

2.2 Doors, Sides, Flue Caps, Top Caps and Casters cont.

ITEM	PART #	COMPONENT
1	2317908	Side, Standard Cabinet Left SS
2	2327908	Side, Standard Cabinet Right SS
3	8101105	Magnet, Door (vertical) (use 8102346 for horizontal over filter pan)
4	1064397	Door, Left or Right (Left shown – move handle to bottom for right) (<i>use 1080915 for Door w/ Manual Holder</i>)
5	2304960	Handle, Eurolook Door
6	1064067	Pin Assy, Door
*	8100275	Spring, Door Pin
*	2307192	Hinge, Door Lower
*	2108288	Panel, Universal Door
*	2206097	Holder, Manual
7	8100327	Caster 4” without Brake
8	8100944	Caster 3” with Brake
9		Flue Cap-Stainless Steel (<i>Use Aluminized steel with Cap-N-Splash</i>)
	8237656	Two Station (<i>8236666 for Alz Steel</i>)(<i>2302635 for Hood Strip</i>) <i>prior to 07/2014</i>
	8238926	Two Station (<i>8236666 for Alz Steel</i>)(<i>2302635 for Hood Strip</i>) <i>after 06/2014</i>
	8237657	Three Station (<i>8236681 for Alz Steel</i>) (<i>2302405 for Hood Strip</i>) <i>prior to 07/2014</i>
	8238927	Three Station (<i>8239032 for Alz Steel</i>)(<i>Use 2302405 for Hood Strip</i>) <i>after 06/2014</i>
	8237658	Four Station (<i>8236680 for Alz Steel</i>) (<i>Use 2302636 for Hood Strip</i>) <i>prior to 07/2014</i>
	8238928	Four Station (<i>8239033 for Alz Steel</i>)(<i>Use 2302636 for Hood Strip</i>) <i>after 06/2014</i>
	8238064	Five Station (<i>8238100 for Alz Steel</i>) (<i>Use 2302637 for Hood Strip</i>) <i>prior to 07/2014</i>
	8238930	Five Station(<i>8239034 for Alz Steel</i>)(<i>Use 2302637 for Hood Strip</i>) <i>after 06/2014</i>
10		Top Cap
	1081522	Two Station Fryer <i>prior to 07/2014</i>
	1086158	Two Station Fryer <i>after 06/2014</i>
	1081523	Three Station Fryer <i>prior to 07/2014</i>
	1086159	Three Station Fryer <i>after 06/2014</i>
	1081524	Four Station Fryer <i>prior to 07/2014</i>
	1086160	Four Station Fryer <i>after 06/2014</i>
	1083030	Five Station Fryer <i>prior to 07/2014</i>
	1086161	Five Station Fryer <i>after 06/2014</i>
*		Cap-N-Splash Assemblies
	8237659	Two Station Fryer
	8237660	Three Station Fryer
	8237661	Four Station Fryer
	8238101	Five Station Fryer

* Not illustrated.

2.3 Drain System Components

2.3.1 Drain Valves and Associated Parts

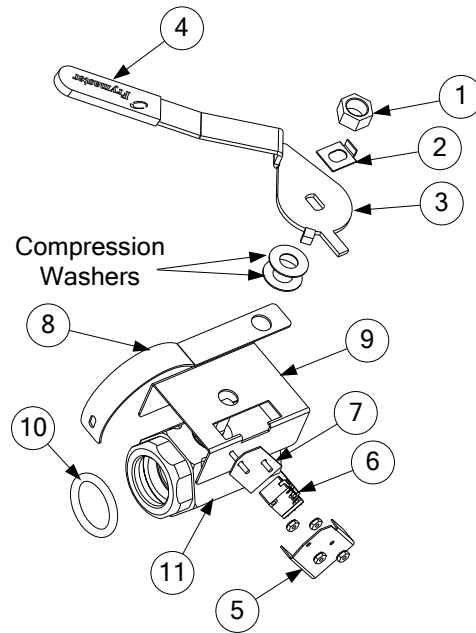

ITEM	PART #	COMPONENT
	108-2509	Valve, Assy Drain FV or DV Left
	108-2510	Valve, Assy Drain DV Right
1	809-0540	Nut, ½-13 2-Way Hex Lock
2	900-2936	Retainer, Nut Drain Valve
3	230-9433	Handle, Drain Valve FV or DV Left
	230-9434	Handle, Drain Valve DV Right
4	814-0047	Cap, Vinyl Red
5	901-2348	Cover, Safety Switch
6	807-4936	Switch, Micro Gold Plated
7	816-0220	Insulation, RF Switch
8	200-6496	Support, Drain Tube
9	108-2506	Bracket Assy, Drain Switch FV and DV Left
	108-2537	Bracket Assy, Drain Switch DV Right
10	816-0135PK	O-Ring, Round Drain Seal
11	810-1018	Valve, 1¼-inch Drain with Filter
*	807-5159	Harness, Drain FV (<i>connects from drain switch to rear of M3000 controller only</i>)
*	807-5160	Harness, Drain DV (<i>connects from drain switch to rear of M3000 controller only</i>)

2.3.2 Drain Tube Sections and Associated Parts

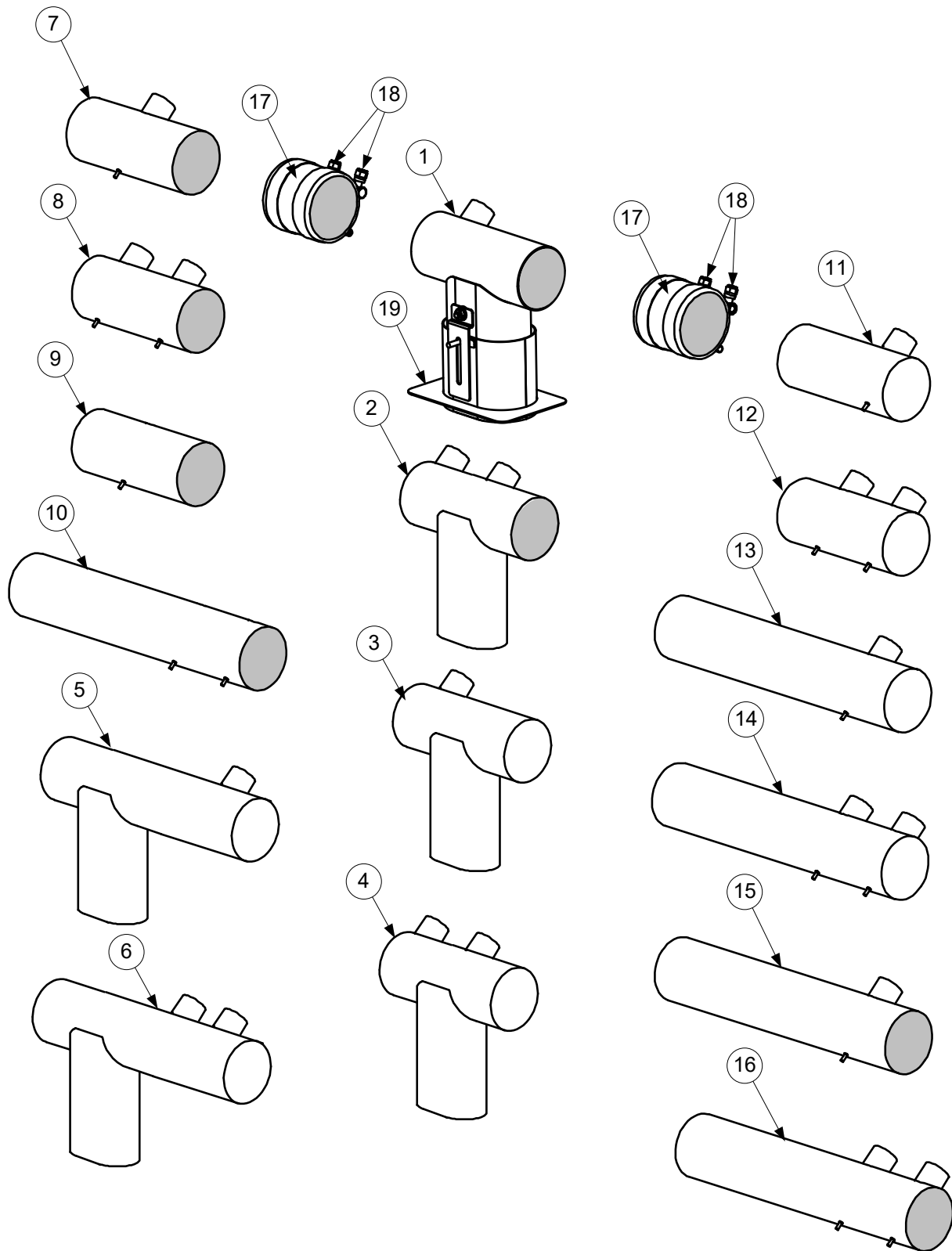

2.3.2 Drain Tube Sections and Associated Parts cont.

ITEM	PART #	COMPONENT
1	823-8135	Drain Tube, Dump Full-Vat Left Closed/Right End Open
2	823-8136	Drain Tube, Dump Dual-Vat Left Closed/Right End Open
3	823-8137	Drain Tube, Dump Full-Vat Left Closed Both Ends
4	823-8138	Drain Tube, Dump Dual-Vat Left Closed Both Ends
5	823-8139	Drain Tube, Dump Full-Vat Left Closed Both Ends
*	823-8130	Drain Tube, Dump Full-Vat Left Closed/Right End Open
6	823-7943	Drain Tube, Dump Dual-Vat Left Closed Both Ends
*	823-8131	Drain Tube, Dump Dual-Vat Left Closed/Right End Open
7	823-4643	Drain Tube, Full-Vat, Short, Open Both Ends
8	823-7905	Drain Tube, Dual-Vat, Short, Open Both Ends
9	810-3550	Drain Tube, Short, Open Both Ends
10	810-3551	Drain Tube, Long, Open Both Ends
11	823-4625	Drain Tube, Short Full-Vat Left Open/Right End Closed
12	823-7906	Drain Tube, Short Dual-Vat Left Open/Right End Closed
13	823-4639	Drain Tube, Long Full-Vat Left Open/Right End Closed
14	823-7908	Drain Tube, Long Dual-Vat Left Open/Right End Closed
15	823-4641	Drain Tube, Long Full-Vat Open Both Ends
16	823-7907	Drain Tube, Long Dual-Vat Open Both Ends
17	816-0772	Sleeve
18	809-0969	Clamp
*	816-0630	Vinyl Cap
*	811-1071	Tubing, ¼-inch OD Teflon Vent (sold by the foot)
19	823-7915	Guard, Filter Lid Splash

* Not illustrated.

2.4 Electronics and Electrical Components

2.4.1 Controllers and Associated Components

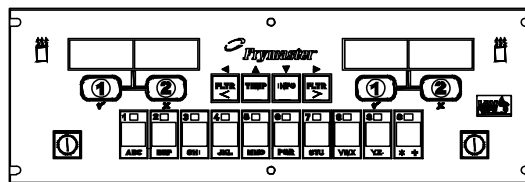

ITEM	PART #	COMPONENT
√ 1	108-5589	Replacement Manual LOV M3000 Controller Gas
	807-4403	Speaker SMT

√ Recommended parts.

2.4.2 Control Box

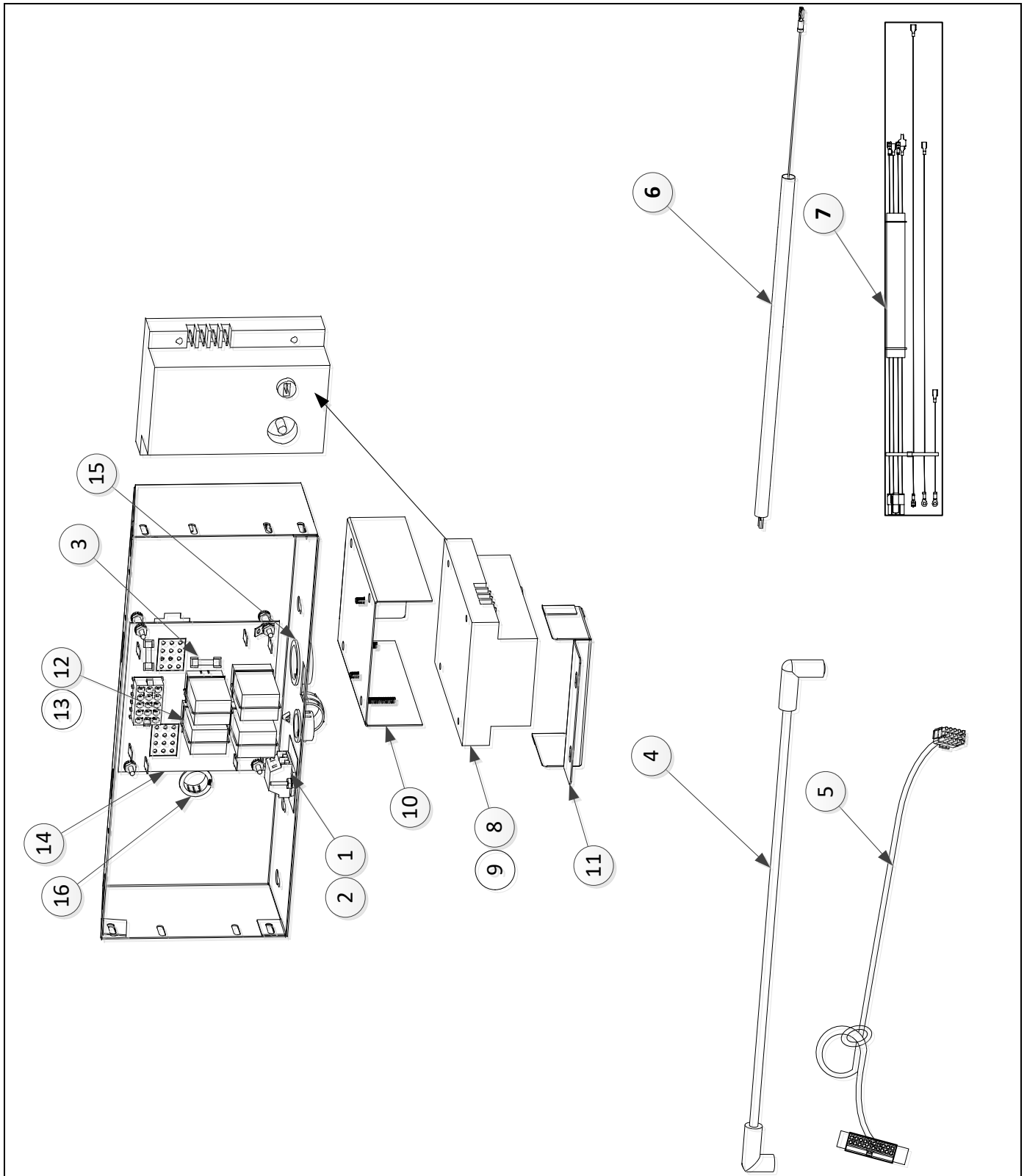

2.4.2 Control Box cont.

ITEM	PART #	COMPONENT
1	810-1164	Block, One-Piece Screwless Terminal
2	816-0217	Insulation, Terminal Block Paper
√ 3	807-3843	Fuse 3A 250V
√ 4	807-5008	Cable, Ignition 19" (CE)
5	807-4199	Cable, 20-pin Computer to 15-pin Interface Board - SMT
6	806-6085SP	Wire Assembly, Ignitor
7	108-2353	Wire Assembly, Ignition Module CE FV
*	108-1260	Wire Assembly, Ignition Module CE DV
√ 8	807-1006	Ignition Module, CE
9	106-0531SP	Fuse Assembly, Inline (<i>not used on all models</i>)
10	108-1094	Plate, Ignition Module
11	824-2091	Cover, Ignition Module CE
√ 12	807-0833	Relay, DPDT 5A 12VDC Latch
13	810-2243	Spring, Relay Retaining
*	807-2659	Switch, Momentary (<i>Control Power Reset, only used in far left component box</i>)
*	807-1683	Relay, 12VDC Reset Switch
√ 14	826-2264	Interface Board
*	807-4343	Wire Harness, SMT Interface Board to Ignition Module
15	807-2469	Bushing, Heyco 1" I.D.
16	810-0045	Bushing, .875

* Not illustrated.

√ Recommended parts.

2.4.3 Transformer Boxes

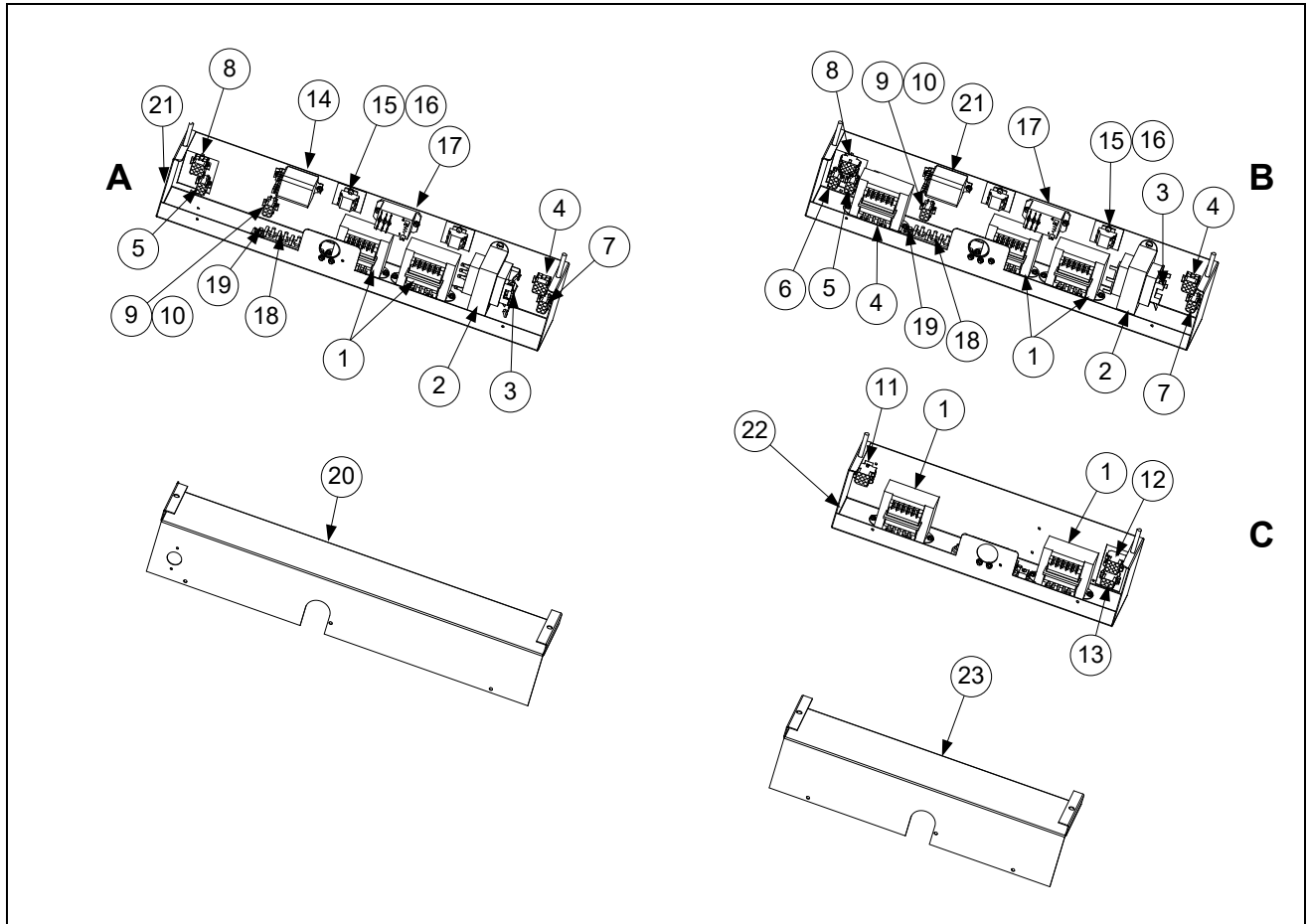

ITEM	PART #	COMPONENT
A	108-1765	BIGL230 and 430 CE and Export (430 has added cordset 108-1770)
B	108-1764	BIGL330 CE and Export
C	108-1768	BIGL430 CE and Export
√ 1	807-5129	Transformer V&F Dual 208/222/230/240V -12V (20VA) / 24V (50VA) Control Box
√ 2	807-2180	Transformer 208-240V/24VAC 50/60HZ, 50VA Filter
√ 3	807-1597	Fuse, 3 Amp Slo-Blow
4	108-0994	Cable Assembly, Transformer Box #1 BIGL230 and 330 CE Export
5	108-0995	Cable Assembly, Transformer Box #2 BIGL230 and 330 CE Export
6	108-0996	Cable Assembly, Transformer Box #3 BIGL 330 CE Export
7	108-1728	Cable Assembly, Transformer Box Filter Pump 230 CE Export
8	106-8170	Cable Assembly, Transformer Box Filter Pump 230 and 330 CE Export
9	108-3433	Harness, Bulk Oil Jumper
10	108-3432	Harness, T-Box Gas OCF
11	108-1778	Harness Assembly, Vat # 4
12	108-1777	Harness Assembly, Vat # 3
13	108-1789	Harness Assembly, 4 Batt Cordset
√ 14	807-4770	Relay, Power Reset DPDT 20A 240V
15	810-1164	Block,1 PLC Screwless Terminal
16	816-0217	Insulation, Terminal Block Paper
√ 17	807-0012	Relay Filter 18 AMP 1/3 HP 24V Coil
18	807-1973	Terminal, Post
19	807-0070	Terminal, Ground Lug

ITEM	PART #	COMPONENT
20	220-3191	Cover, Large Transformer Box
21	823-6324	Box, Large Transformer/Filter
22	823-7638	Box, Transformer/Filter GL30 4-Battery
23	220-6514	Cover, GL30 Small Transformer Box
*	WIR 0100	Wire Assembly, 430 (used in Items C)
*	WIR 0799	Wire Assembly, GL230 Transformer/Filter Box (used in Item A)
*	WIR 0798	Wire Assembly, GL330 Transformer/Filter Box (used in Item B)
*	WIR 0957	Wire Assembly, GL230/430 (used in Items A and B)

* Not illustrated.

√ Recommended parts.

2.5 Wiring

2.5.1 Main Wiring Harnesses

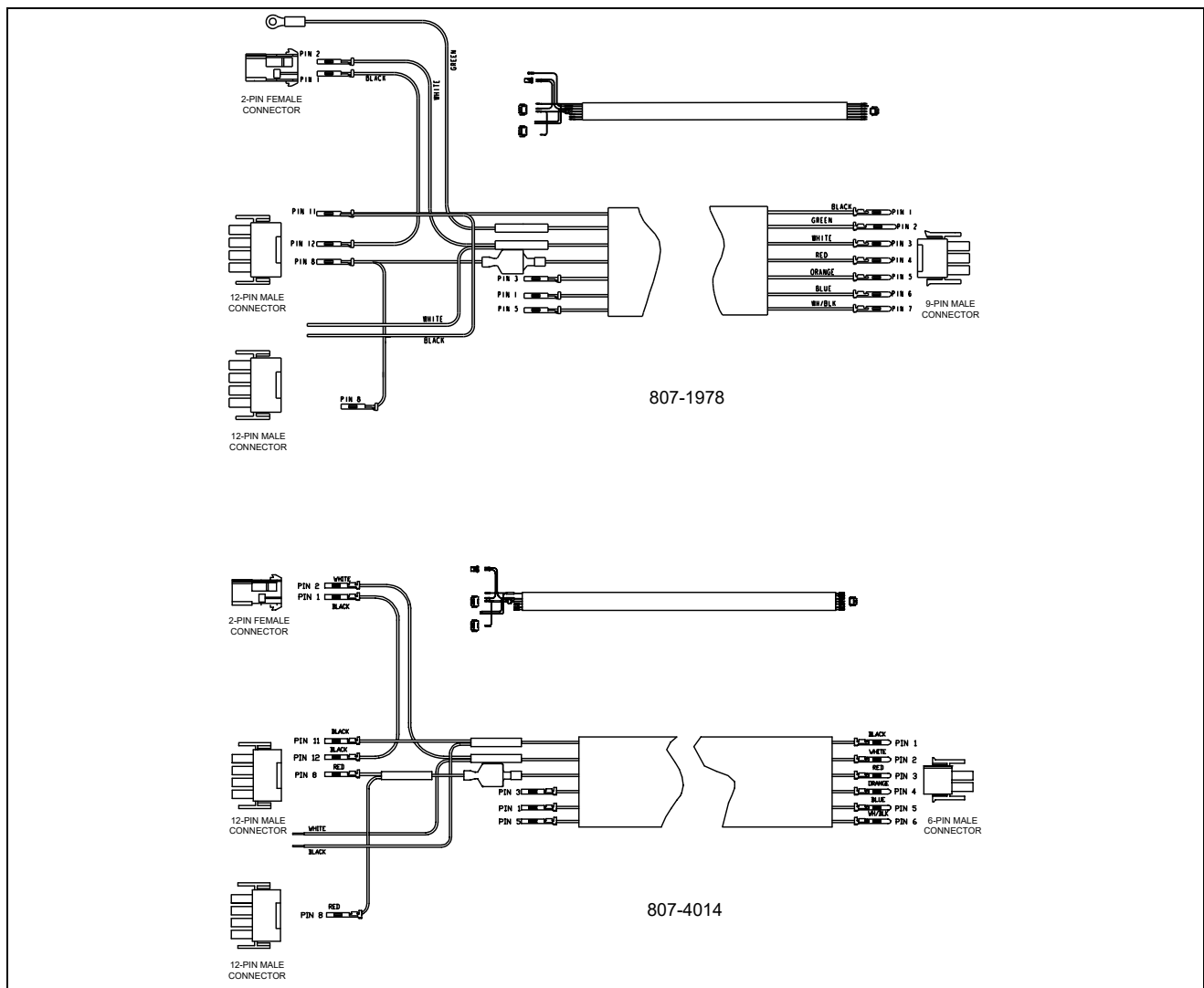

ITEM	PART #	COMPONENT
	807-1978	Main Wiring Harness 230/430
	807-4014	Main Wiring Harness 330

2.5.2 M3000 Communication Wiring Harnesses (Refer to wiring diagram on page 1-41.)

ITEM	PART #	COMPONENT
*	807-4546	Controller Communication <i>(used from controller to controller)</i>
*	807-4573	Controller Locator Wire <i>(used from controller to interface board) See wiring diagram on page 1-41 for locator pin positions.</i>
*	807-4552	Communications Terminator <i>(used on controller pin J6 and J7 to terminate network)</i>
√ *	807-4660PK	SMT Pin Service Repair Kit
√ *	230-2345	SMT Pin Extractor

* Not illustrated.

√ Recommended parts.

See page 1-33 for Pin Positions.

2.6 Frypots and Associated Components

2.6.1 Full-Vat Frypot Components

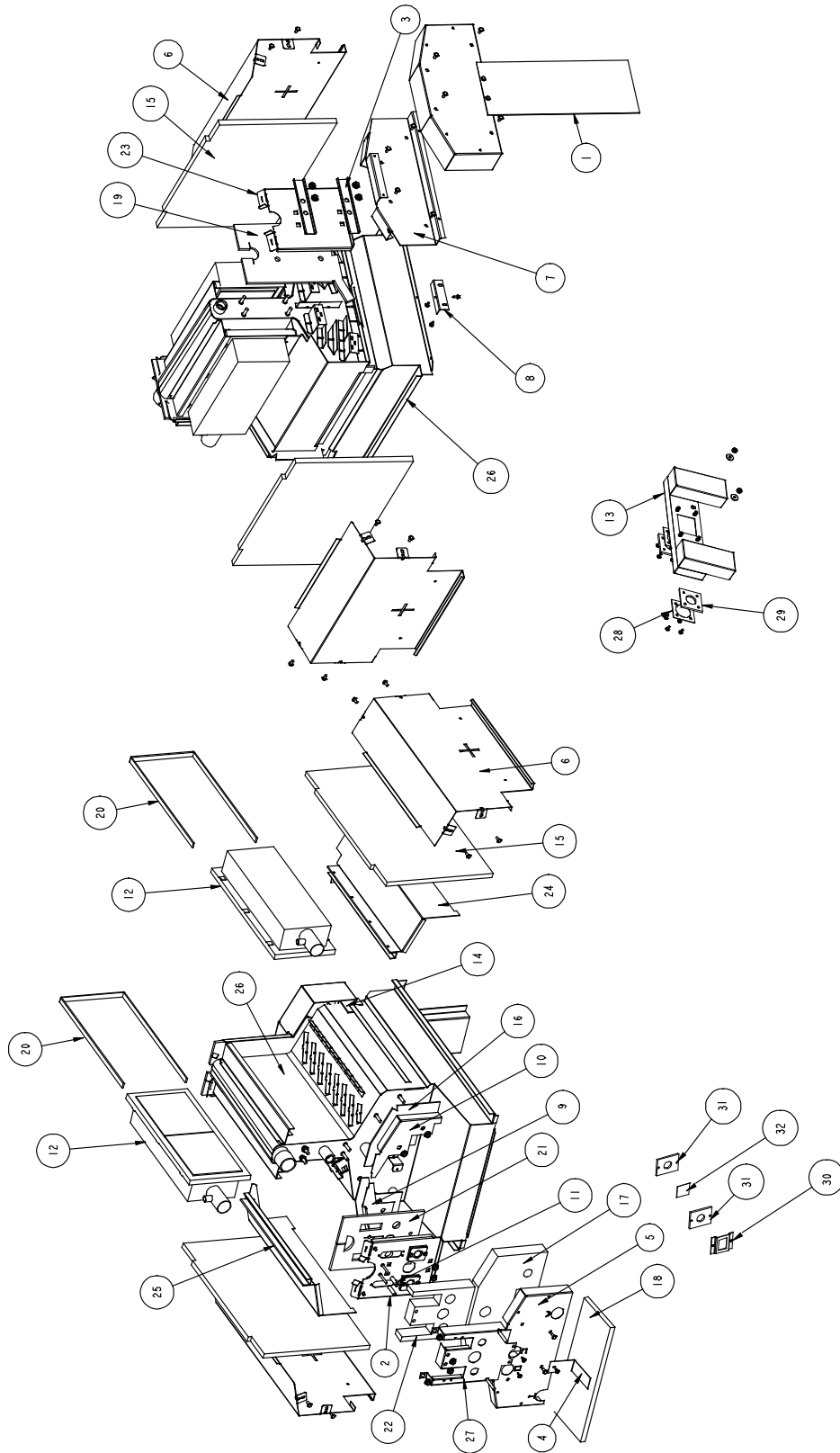

2.6.1 Full-Vat Frypot Components cont.

ITEM	PART #	COMPONENT
	108-4156	Frypot Assembly, Manual LOV Full-Vat
1	108-2897	Flue assembly, FV Frypot
2	108-4423	Cover assembly, GL30 FV Front Combustion
3	220-2851	Brace, H30 FV Rear
4	220-2920	Brace, GL30 Foam Deck
5	220-6529	Cover, GL30 FV Upper Insulation
6	220-7831	Retainer FV Insulation
7	230-6960	Plate, GL30 FV Collector
8	930-0818	Bracket Flue to Pot
9	824-2165	GL30 FV RH Upper Seal
10	824-2164	GL30 FV LH Upper Seal
11	810-0476	Spacer .250 x 1 187
√ 12	810-3435	Burner, HE30, Universal
13	823-8590	Plenum, Full-Vat (<i>use 823-6660 for Non-CE units</i>)
*	810-3743	Fitting, 1/8 NPT x 3/16 Barb (used on plenum)
√ *	826-2592	Insulation Kit, Burner Full-Vat
*	826-2595	Insulation Kit, Complete Full-Vat
14	812-0706	Insulation, Upper Burner Rail
15	812-1029	Insulation, Burner Side
16	816-0731	Insulation, Front, L/R
17	816-0733	Insulation, Front
18	816-0746	Insulation, Foam Deck
19	816-0837	Insulation, FV Rear Lower
20	816-0900	Insulation, Burner
21	816-0976	Insulation, Lower Front
22	816-0978	Insulation, Outer Front
23	823-8175	Cover GL30 FV Rear Combustion
24	823-8193	Retainer GL30 FV LH Burner
25	823-8194	Retainer GL30 FV RH Burner
26	823-8470	Frypot FV <i>prior to 07/2014</i>
	823-8981	Frypot FV <i>after 06/2014</i>
27	823-8575	Cover GL30 FV Lower Outer
28	900-1049	Retainer, Plenum Gasket
29	816-0057	Gasket, Plenum
30	900-1031	Retainer, Burner Sight Glass
31	812-0356	Insulation, Burner Sight Glass
32	814-0048SP	Glass, Burner Sight

* Not illustrated

√ Recommended parts.

2.6.2 Dual-Vat Frypot Components

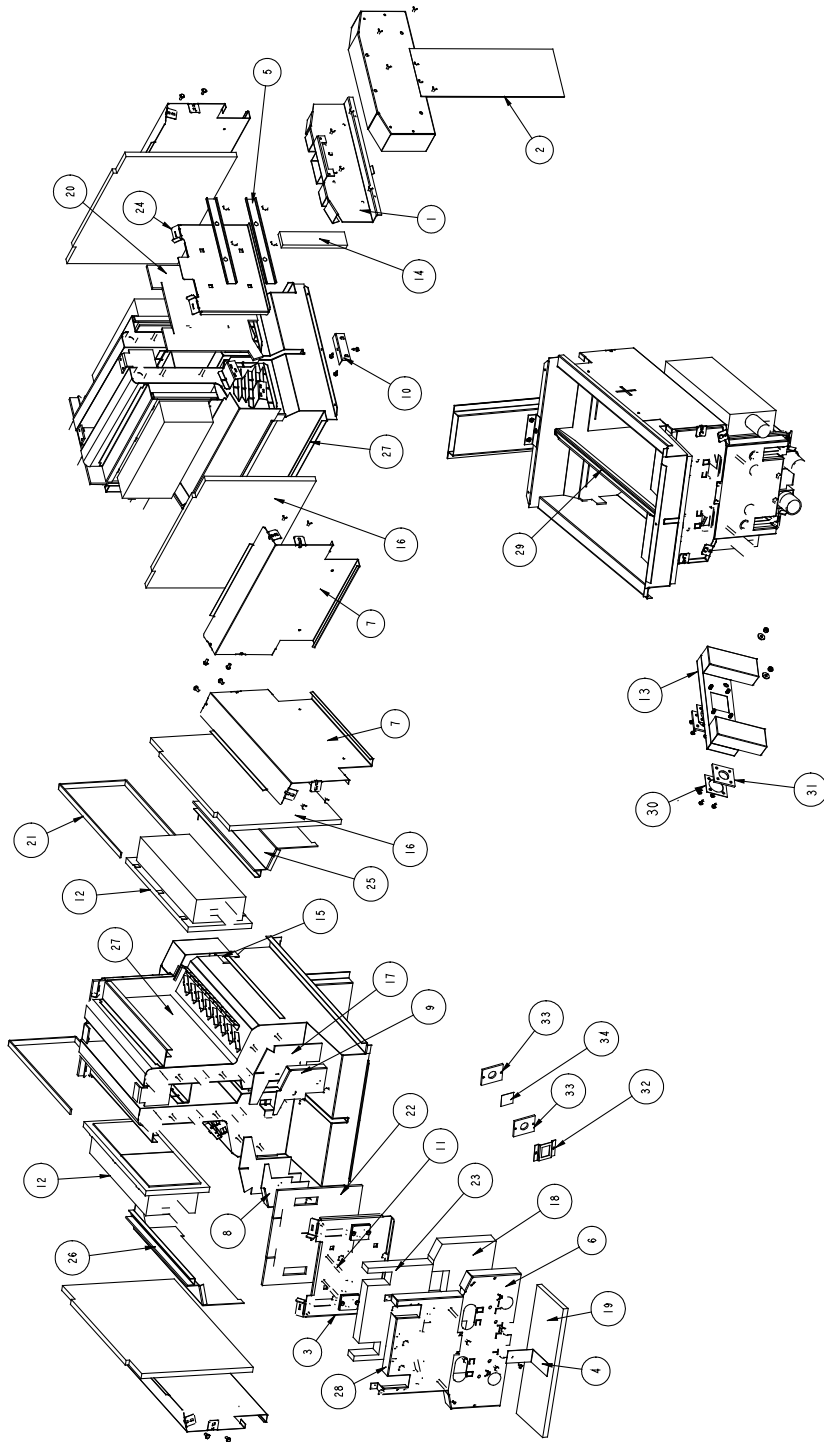

2.6.2 Dual-Vat Frypot Components cont.

ITEM	PART #	COMPONENT
	108-4157	Frypot Assembly, Manual LOV Dual-Vat
1	106-7690	Plate Assy, DV Collector
2	108-2898	Flue assembly, DV Frypot
3	108-4424	Cover assembly, GL30 DV Front Combustion
4	220-2920	Brace, GL30 Foam Deck
5	220-2972	Brace, Dual-Vat Rear Insulation
6	220-6530	Retainer, Dual-Vat Upper Insulation
7	220-7916	Retainer, Dual-Vat Outer Frypot
8	824-2167	Seal Weldment, DV RH Upper
9	824-2166	Seal Weldment, DV LH Upper
10	930-0818	Bracket Flue to Pot
11	810-0476	Spacer .250 x 1 187
√ 12	810-3435	Burner, HE30, Universal
13	823-8589	Plenum, Dual-Vat (<i>use 823-7582 for Non-CE units</i>)
*	810-3743	Fitting, 1/8 NPT x 3/16 Barb (used on plenum)
√ *	826-2596	Insulation Kit, Complete Dual-Vat
*	826-2593	Insulation Kit, Burner Dual-Vat
14	812-0688	Insulation, Flue Collection
15	812-0706	Insulation, Upper Burner Rail
16	812-1029	Insulation, Burner Side
17	816-0741	Insulation, Dual-Vat LH/RH Front Seal
18	816-0743	Insulation, Dual-Vat Front Upper
19	816-0746	Insulation, Foam Deck
20	816-0838	Insulation, Dual-Vat Rear Lower
21	816-0900	Burner, Insulation
22	816-0977	Insulation, DV Lower Inner Front
23	816-0979	Insulation, DV Outer Front
24	823-8176	Cover GL30 DV Rear Combustion
25	823-8195	Retainer GL30 DV LH Burner
26	823-8196	Retainer GL30 DV RH Burner
27	823-8476	Frypot DV <i>prior to 07/2014</i>
	823-8977	Frypot DV <i>after 06/2014</i>
28	823-8576	Cover GL30 DV Lower Outer
29	824-1796	Riser Weldment, DV
30	900-1049	Retainer, Plenum Gasket
31	816-0057	Gasket, Plenum
32	900-1031	Retainer, Burner Sight Glass
33	812-0356	Insulation, Burner Sight Glass
34	814-0048SP	Glass, Burner Sight

* Not illustrated

√ Recommended parts.

2.6.3 Frypot Probes and Thermostats

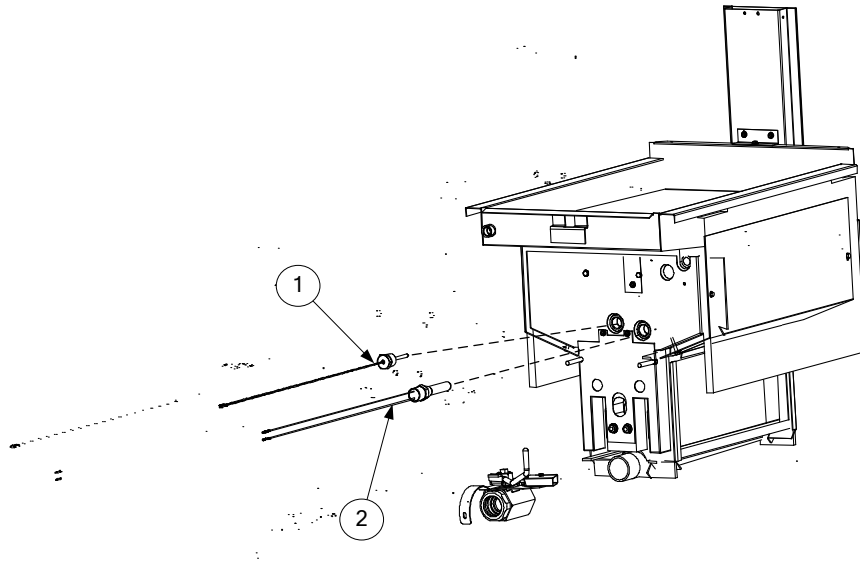

See page 2-3 for Drain Valve Assemblies and page 2-11 through 2-14 for Frypot Assemblies

ITEM	PART #	COMPONENT
√ 1	826-2900	Probe, Temperature Cooking
√ 2	826-1177	Thermostat, High-Limit 425°F/218°C

√ Recommended parts.

2.7 Gas Valves, Supply and Combustion System Components

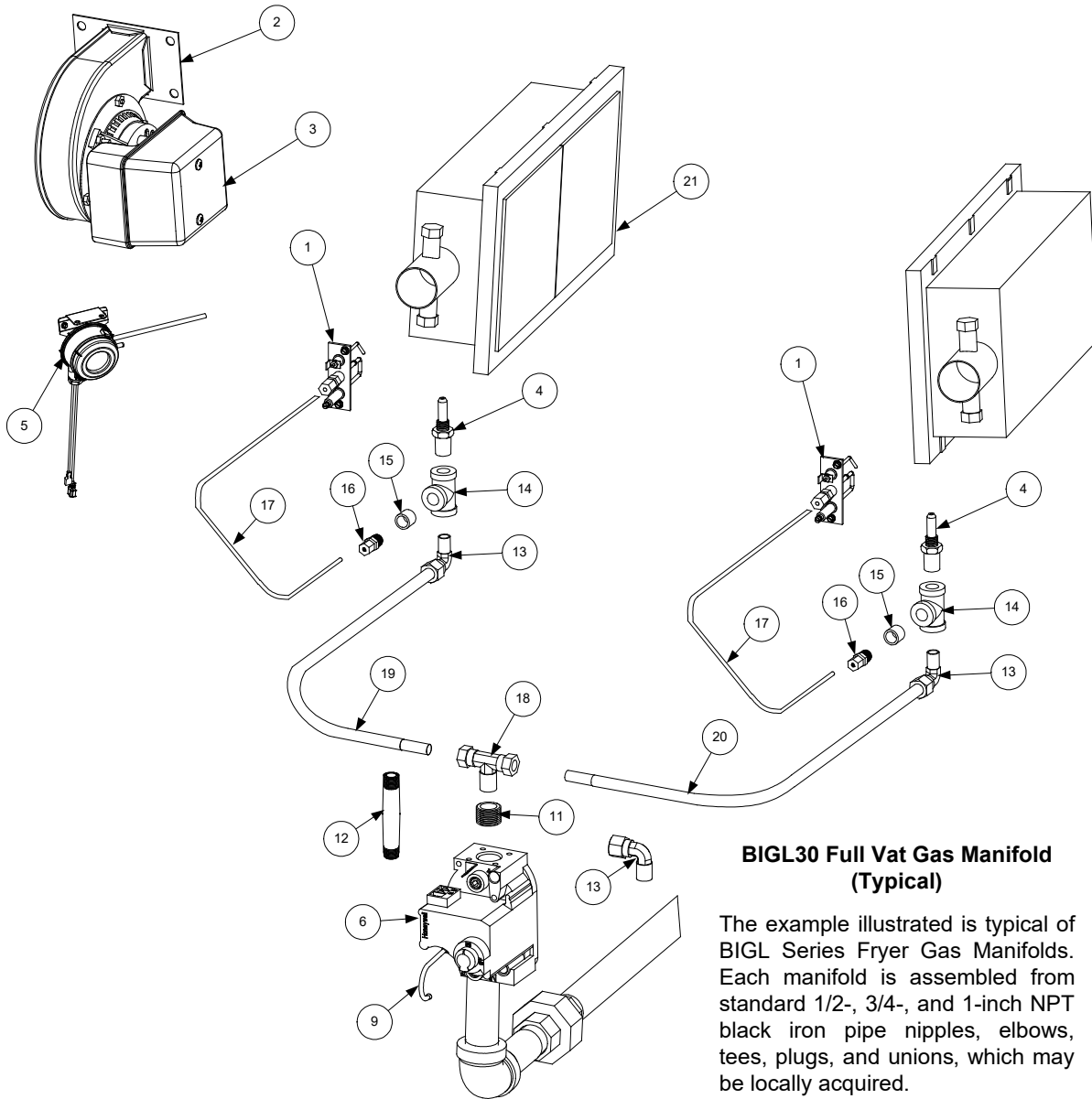

**Non-CE Gas Valve Assembly
(Typical)**

**BIGL30 Full Vat Gas Manifold
(Typical)**

The example illustrated is typical of BIGL Series Fryer Gas Manifolds. Each manifold is assembled from standard 1/2-, 3/4-, and 1-inch NPT black iron pipe nipples, elbows, tees, plugs, and unions, which may be locally acquired.

NOTE: The gas tube and enrichment tube fittings are assembled in varying configurations depending upon the location of the valve and whether the associated frypot is a full- or dual-vat pot.

ITEM	PART #	COMPONENT
√ 1		Ignitor
	826-3053	Natural Gas (G20, G25) (includes gasket 816-0059)
	826-2994	Propane (G30, G31) (includes gasket 816-0981)
√ 2		Blower Assembly, Combustion Air (includes harness and Item 3)
	108-1960	230V 50HZ RH CE (Dual Vat)
	108-1959	230V 50HZ RH CE (Full Vat)
3	816-0554	Cover, Blower Motor (component of all blowers listed above)
*	807-1067	Harness Assembly, Blower Motor

2.7 Gas Valves, Supply and Combustion System Components cont.

ITEM	PART #	COMPONENT
4		Orifice, Burner
	810-3861	3.26 mm Natural Gas (G20, G25) (0-4999 Ft, 0-1524 M)
	810-3865	1.95 mm Propane/Butane (G30, G31) (0-4999 Ft, 0-1524 M)
√ 5	108-3346	Switch, Air Pressure Assembly Full Vat (812-2226 switch alone)
	108-1455	Switch, Air Pressure Assembly Dual Vat (812-2141 switch alone)
√ 6		Valve, Non-CE Gas
	826-1122	Natural Gas (G20, G25)
	826-1120	Kit Natural Gas w/ flexlines and hardware
	826-1123	Propane Gas (G30, G31)
	826-1121	Kit, Propane Gas w/ flexlines and hardware
9	810-0691	Tube, 1/8-inch Vent
10	806-9678SP	Plug Assy, CE Gas Valve
11	813-0304	Bushing, 1/2-inch NPT to 1/4-inch NPT Flush Reducing
12	813-0700	Nipple, 1/4-inch NPT x 3-inch
13	813-0302	Elbow, 1/4-inch Male NPT to 3/8-inch Tube 90° (used on DV valve)
14	813-0449	Tee, 1/4 -inch NPT Brass
15	810-3147	Bushing, 3/4-inch OD x 1/2 -inch ID NPT Flush
16	813-0340	Adapter, 1/8-inch NPT to 1/8-inch Tube
17	810-3807	Tube, 1/8-inch OD X 6.5-inch Enrichment
18	813-0301	Tee, 1/4-inch Male NPT to 3/8-inch Tube
19	810-1353	Gas Line, 3/8-inch OD X 9-inch SS Flexible (Used on some split pots)
20	810-1355	Gas Line, 3/8-inch OD X 15-inch SS Flexible
21	810-3435	Burner, HE30, Universal
*	826-2965	Conversion Kit, Natural Gas FV (G20, G25) to Propane/Butane(G30,G31)
*	826-2966	Conversion Kit, Natural Gas DV (G20, G25) to Propane/Butane(G30,G31)
*	826-2967	Conversion Kit, Propane/Butane FV(G30, G31) to Natural Gas (G20,G25)
*	826-2968	Conversion Kit, Propane/Butane DV(G30, G31) to Natural Gas (G20,G25)
*	826-2969	Conversion Kit, Natural Gas FV (G20, G25) to Prop/Butane(G30,G31) Aust /CE
*	826-2970	Conversion Kit, Natural Gas DV (G20, G25) to Prop/Butane(G30,G31) Aust/CE
*	826-2971	Conversion Kit, Prop/Butane FV(G30, G31) to Natural Gas (G20,G25) Aust /CE
*	826-2972	Conversion Kit, Prop/Butane DV(G30, G31) to Natural Gas (G20,G25) Aust/CE

* Not illustrated.

√ Recommended parts.

2.8 Filtration System Components

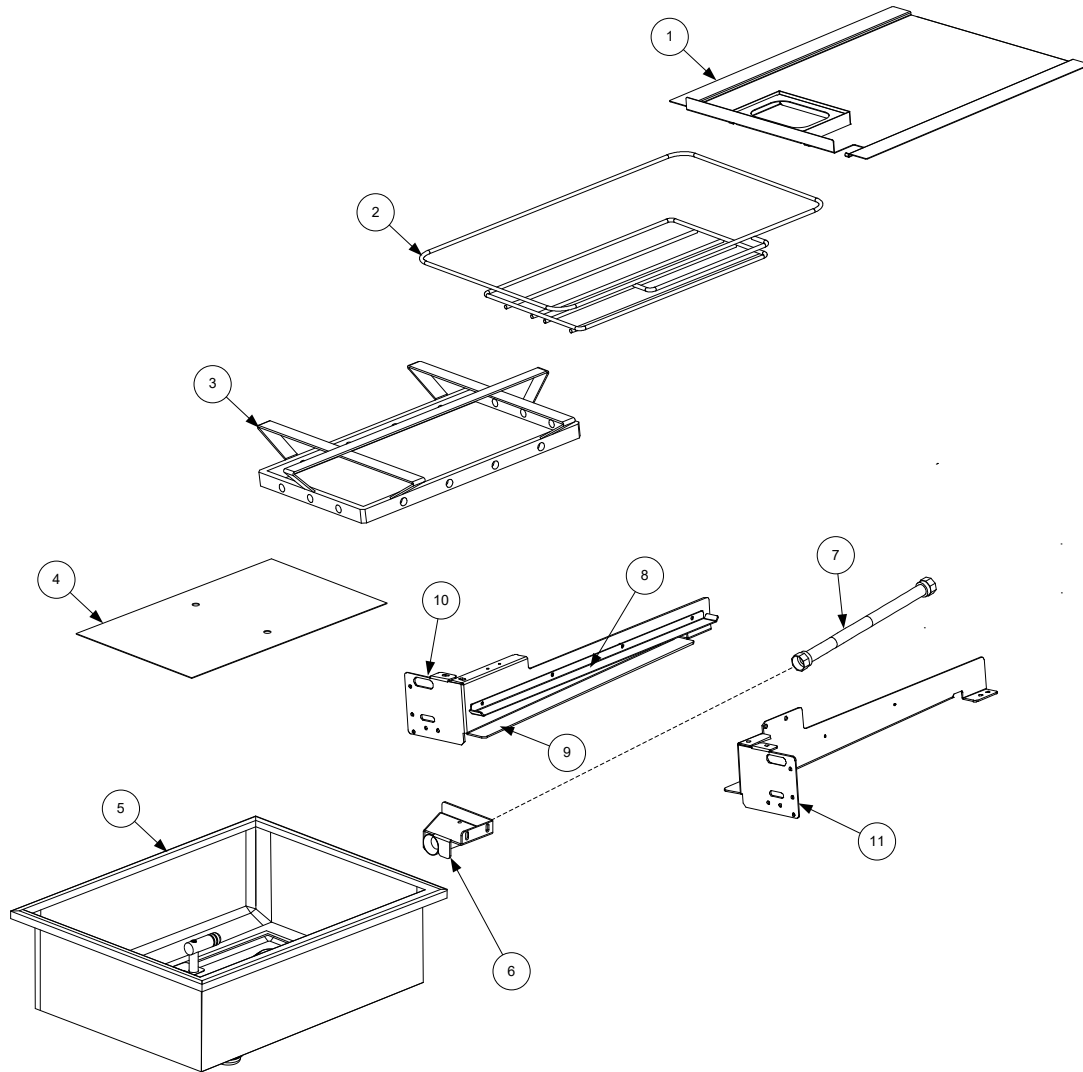

ITEM	PART #	COMPONENT
1	823-8028	Lid, Filter Pan
2	810-3276	Crumb Tray
3	810-3289	Hold-Down Ring 11.20 x 19.10,
4	812-2025	Sana Grid Filter Screen
5	108-3999	Pan, Filter
	813-0568	Plug, 1/8-inch Socket Head Pipe (used with Item 5; two required)
√ *	826-1392	O-Ring (Pkg. of 5; used with Item 5)
6	823-6458	Suction Tube Assembly
7	810-1067	Flexline, 8.50-inch Oil Return
8	230-8373	Rail, Upper Filter Pan Left/Right
9	230-8372	Rail, Lower Filter Pan Left/Right
10	823-8030	Support, Left Filter Pan
11	220-8368	Support, Right Filter Pan 3,4 and 5 battery

* Not illustrated.

√ Recommended parts.

2.9 Filter Pump, Motor and Associated Components

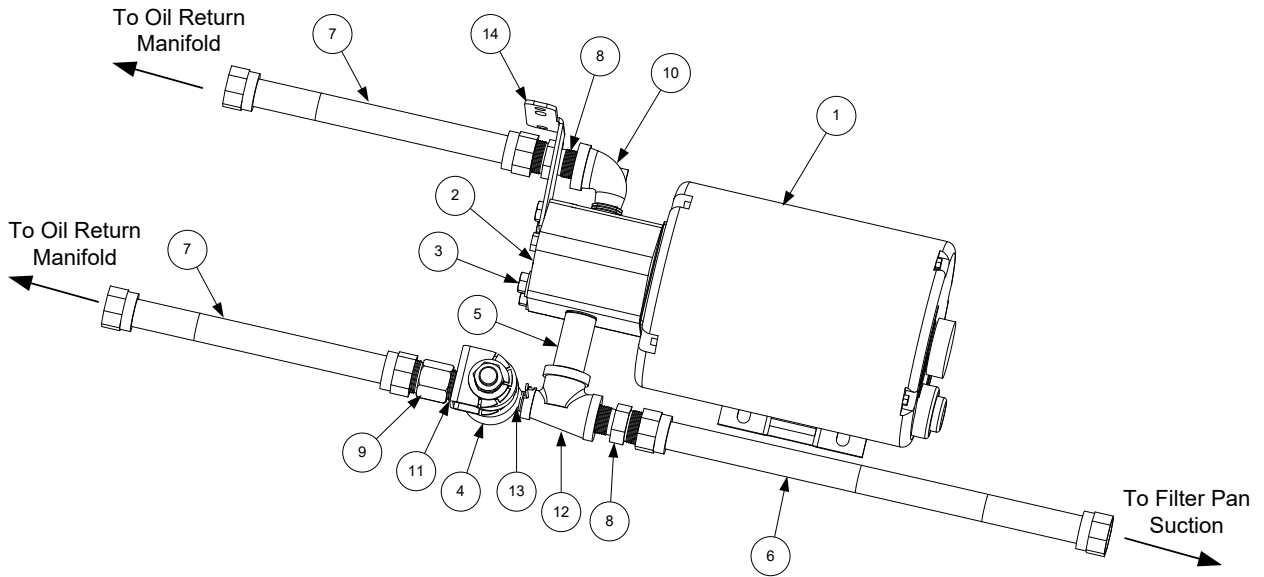

ITEM	PART #	COMPONENT
1		Motor and Gasket Kit
	826-1785	100V 50/60 Hz
	826-1712	115V 50/60 Hz
	826-1756	208V 50/60 Hz
√	826-1270	220-240V 50/60 Hz
	826-1755	250V 50/60 Hz
2	826-3191	Pump and Gasket Kit, Viking 4 GPM (includes gasket and cap screws below)
	816-0093	Gasket, Pump/Motor
3	809-1062	Cap Screw, 5/16-inch-18 4.00" NC Hex (<i>Connects pump to motor, use 8090194 washer</i>)
*	108-0649	Heater Strip Assembly, 100-120V 25W 18"
*	106-5912	Heater Strip Assembly, 208-250V 25W 18"
4	106-3470	Valve, Solenoid 1/4-inch" NPT
5	813-0265	Nipple, 1/2-inch x 2.50-inch NPT BM
6	810-1057	Flexline, 13-inch Oil Return
7	810-1067	Flexline, 8.5-inch Oil Return
8	810-1668	Adapter, 5/8-inch to 1/2-inch NPT Male
9	810-1669	Adaptor, Female 7/8-inch OD x 1/2-inch
10	813-0165	Elbow, ST 1/2-inch x 1/2-inch NPT 90° BM
11	813-0304	Bushing, 1/2-inch x 1/4-inch BM Flush
12	813-0530	Tee, Reducing 1/2-inch x 1/4-inch x 1/2-inch
13	813-0838	Nipple, 1/4-inch NPT BM Close
14	220-6191	Brace
*	106-1020	Wiring, Pump

* Not illustrated.

√ Recommended parts.

2.10 Frypot Assemblies and Associated Parts

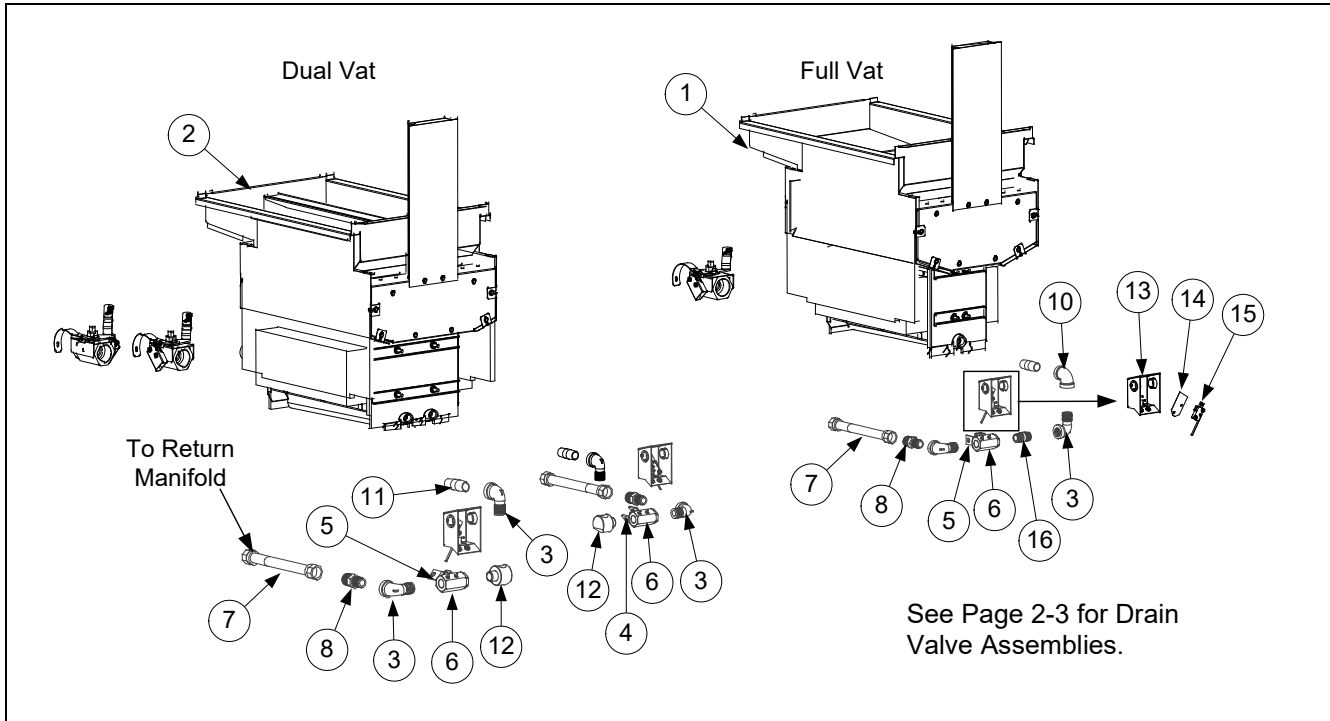

ITEM	PART #	COMPONENT
1	823-8470	Frypot, Full-Vat
2	823-8476	Frypot, Dual-Vat
*	824-1796	Riser, DV Frypot
3	813-0022	Elbow, St ½" x ½" NPT 90° BM
4	901-2772	Handle, Valve Rear Flush LT
5	902-2772	Handle, Valve Rear Flush RT
*	900-2935	Retainer, Nut Oil Return Valve
6	810-2201	Valve, Return ½" Ball LT
7	810-1067	Flexline, ⅝" OD x 8.50" Long Return Oil
8	810-1668	Adaptor, Male ⅝" OD x ½"
10	813-0062	Elbow, ½" BM x 90°
11	813-0298	Nipple, ½" x 2.00" NPT BM Pipe
12	813-0908	Adapter, ½" NPT 90°
13	824-2223	Cover, Oil Return Microswitch
14	816-0220	Insulation, RF Switch
15	807-4101	Switch, Micro
16	813-0087	Nipple, ½" x 1.50" NPT BM Pipe

* Not illustrated.

2.11 Oil Return System Components

Typical Rear-Flush Oil Return Plumbing

Return valve assemblies are shown on preceding page.

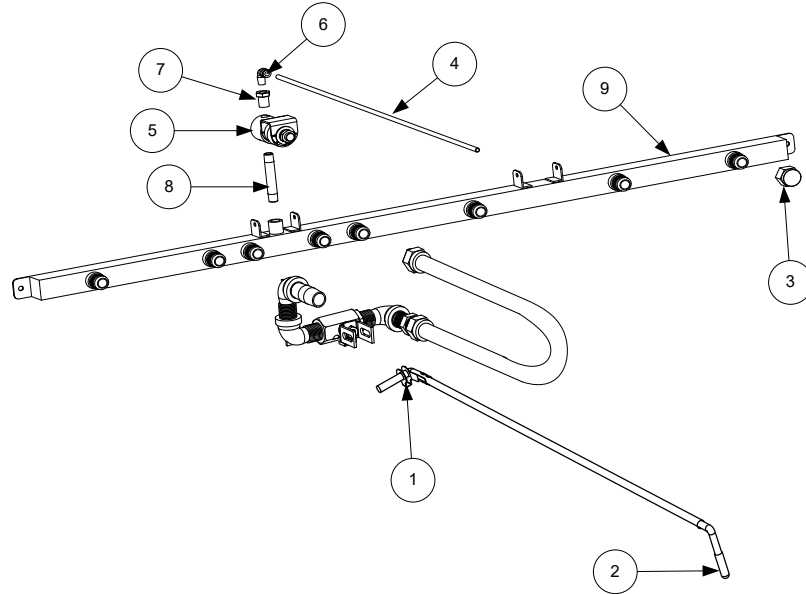

ITEM	PART #	COMPONENT
1	809-0601	Clip, Clevis
2	816-0643	Grip, Oil Return Valve Handle
3	813-0907	Cap, 15/16-inch Valve Safety
4	811-1071	Tube, 1/4-inch OD Teflon Manifold Vent
5	106-3470	Valve, 1/4-inch NPT Solenoid
6	810-2493	Elbow, 90° 1/8-inch NPT x 1/4-inch Quick Connect
7	813-0807	Bushing, 1/4-inch NPT x 1/8-inch
8	813-0700	Nipple, 1/4-inch NPT x 3.00-inch
9		Manifolds
*	810-3958	Manifold, Two-Station Fryer
*	810-3959	Manifold, Three-Station Fryer
*	810-3960	Manifold, Four-Station Fryer
*	810-3961	Manifold, Five-Station Fryer

* Not illustrated.

2.12 Wiring Connectors, Pin Terminals and Tools

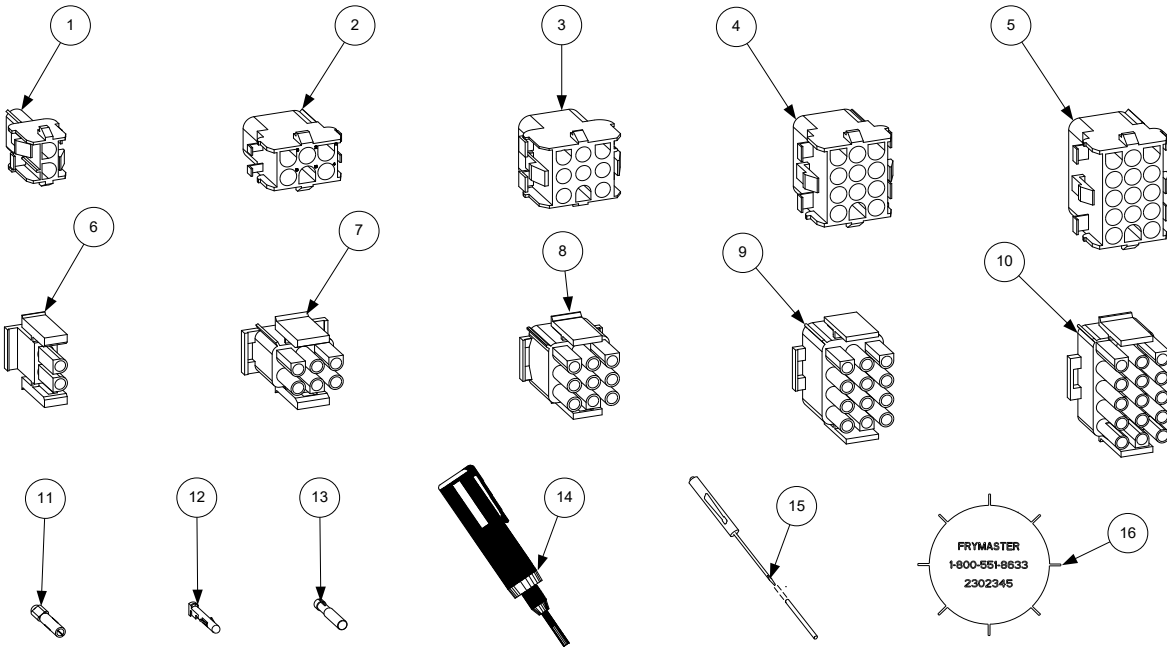

ITEM	PART #	COMPONENT
1	807-1068	2-Pin Female
2	807-0158	6-Pin Female
3	807-0156	9-Pin Female
5	807-0159	12-Pin Female
5	807-0875	15-Pin Female
6	807-1067	2-Pin Male
7	807-0157	6-Pin Male
8	807-0155	9-Pin Male
9	807-0160	12-Pin Male
10	807-0804	15-Pin Male
11	826-1341	Terminal, Female Split Pin (Pkg of 25)
12	826-1342	Terminal, Male Split Pin (Pkg of 25)
13	807-2518	Plug, Mate-N-Lock (Dummy Pin)
14	807-0928	Extract Tool Pin Pusher
15	806-4855	Pin Pusher Screwdriver Assy
16	230-2345	SMT Pin Extractor

* Not illustrated.

2.13 Fasteners

ITEM	PART #	COMPONENT
*	809-0429	Bolt, ¼-inch – 20 x 2.00-inch Hex Head ZP Tap
*	809-0131	Bolt, ¼-inch -20 x ¾-inch Hex
*	809-0953	Bolt, ¼-20 x ¾-inch Hex Head
*	807-1926	Bushing, .875-inch Split
*	809-0514	Capscrew, 5/16-inch-18 NC Hex
*	809-0448	Clip, Tinnerman
*	826-1351	Nut Retainer, ¼-20 (Pkg. of 10 – for basket hanger thumbscrew) Std. Fluecap
*	809-0171	Thumbscrew, ¼-20 x 1⅜-inch (for use on Standard Fluecap)
*	826-1366	Nut, 4-40 Keps Hex (Pkg. of 25) (809-0237)
*	826-1358	Nut, 6-32 Keps Hex (Pkg. of 25) (809-0049)
*	809-0247	Nut, 8-32 Keps Hex
*	809-0052	Nut, 10-24 Hex
*	826-1376	Nut, 10-32 Keps Hex (Pkg. of 10) (809-0256)
*	809-0766	Nut, 10-32 Keps Hex SS
*	809-0581	Nut, ½ NPT Locking
*	809-0020	Nut Cap 10-24 NP
*	826-1372	Nut Grip ¼-inch ¼-20 Hex NP (Pkg. of 10) (809-0059)
*	809-0417	Nut Flange ¼-inch ¼-20 Serr
*	809-0535	Nut, "T" ¼-inch-20 x 7/16 SS
*	809-0495	Nut, ¼-inch - 20 Press
*	809-0804	Nut, ¼- inch - 20 Keps Hex
*	826-1362	Nut, ¼-20 Hex (Pkg. of 10) (809-0071)
*	809-0540	Nut, Lock ½-inch-13 Hex 2-Way ZP
*	809-0656	Screw, 4-40 X 3/8-inch Slotted Round Head
*	826-1359	Screw, 4-40 x ¾-inch Slotted Round Head (Pkg. of 25) (809-0354)
*	826-1365	Screw, 6-32 x ⅜-inch Slot Head (Pkg. of 25) (809-0095)
*	809-0098	Screw, 6-32 x 1¼-inch Slotted Round Head
*	809-0357	Screw, 6 x ⅜-inch Phillips Head NP
*	809-0359	Screw, 8 x ¼-inch Hex Washer Head
*	809-0360	Screw, 8 x ⅜-inch Hex Washer Slot Head
*	826-1371	Screw, 8 x ½-inch Hex Head ZP (Pkg. of 25) (809-0361)
*	809-0364	Screw, 8 x ⅝-inch Hex Washer Head ZP
*	809-0441	Screw, 8 x 1½-inch Hex Washer Head
*	809-0362	Screw, 8 x 1¼-inch Hex Washer Head Drill Point
*	809-0518	Screw, 8-32 x ⅜-inch Hex Washer Slotted Head SS
*	809-0104	Screw, 8-32 x ½-inch Slotted Head ZP
*	826-1363	Screw, 8-32 x ½-inch NP (Pkg. of 25) (809-0103)
*	826-1360	Screw, 10-24 x 5/16-inch Round Slot Head ZP (Pkg. of 25) (809-0024)
*	809-0123	Screw, 10-24 x 3/4-inch Slotted Truss Head
*	826-1330	Screw, 10-32 x ⅜-inch Slot Head SS (Pkg. of 25) (809-0117)
*	809-1003	Screw, 10-32 x ⅜-inch Hex Trim Head SS
*	809-0938	Screw, 10-32 x ⅝-inch Philips Truss Head
*	826-1375	Screw, 10-32 x ¾-inch Hex Trim Head SS (Pkg. of 5) (809-0401)
*	809-1000	Screw, 10-32 x 1¼-inch Hex Sck C/S
*	826-1374	Screw, 10 x ½-inch Hex Head (Pkg. of 25) (809-0412)
*	809-0266	Screw, 10 x ½-inch Phillips Head ZP

continued on the following page

2.13 Fasteners cont.

ITEM	PART #	COMPONENT
*	809-0500	Screw, 10 x ½-inch Hex Washer Head 410 SS
*	809-0434	Screw, 10 x ⅜-inch Hex Washer Head NP
*	809-0123	Screw, 10 x ¾-inch Slot Head
*	826-1389	Screw, ¼-20 x ¾-inch Hex Head ZP (Pkg. of 10) (809-0131)
*	826-1346	Spacer, Ignition Module (Pkg. of 10)
*	810-2763	Spacer, Interface Board
*	826-1340	Spacer, .25-inch x 1.187-inch (Pkg. of 10)
*	810-0500	Spacer, .25-inch x .9375-inch
	810-2023	Spacer, .25-inch x .110-inch (Used on drain valves.)
*	200-6721	Plate, Strain Relief
*	826-1337	Tab, ¼-inch Terminal (Pkg. of 5)
*	807-0070	Terminal, Ground Lug
*	807-1948	Ty-Wrap
*	807-1359	Mount, Ty-Wrap
*	826-1383	Washer, ¾-inch O.D. x ¼-inch I.D. ZP (Pkg. of 5) (809-0435)
*	809-0582	Washer ½ NPT Locking
*	809-0184	Washer, #10 LK ZP
*	809-0190	Washer, .625 X .275 X 40 Flat SS
*	809-0191	Washer, Lock ¼ Spring ZP
*	809-0193	Washer, Flat ¼ Nylon
*	809-0194	Washer, Flat 5/16 ZP
*	809-0196	Washer, ⅜-inch Flat
*	810-1165	Washer, ⅜-inch Teflon

Frymaster[®]

FRYMASTER
8700 LINE AVENUE, SHREVEPORT, LA 71106-6800

800-551-8633
318-865-1711
WWW.FRYMASTER.COM
EMAIL: FRYSERVICE@WELBILT.COM



Welbilt offers fully-integrated kitchen systems. Welbilt's portfolio of award-winning brands includes Cleveland™, Convotherm®, Crystal Tips®, Dean®, Delfield®, Fabristeel®, Frymaster®, Garland®, Inducs®, Koldtech®, Kolpak®, Lincoln®, McCann's™, Merco®, Merrychef®, Multiplex®, RDI®, SerVend™, SunFire®, U.S. Range™, and WMaxx™. Supported by service brands: FitKitchen®, kitchen systems; and KitchenConnect®, cloud-based open platform.

Bringing innovation to the table • welbilt.com

©2023 Frymaster LLC. except where explicitly stated otherwise. All rights reserved. Continuing product improvement may necessitate change of specifications without notice.

Part Number FRY_SP_8196968 10/2023