



Service, Parts Manual for 4, 2-Slot and Narrow Models

# UHC-P /HCP



Frymaster, a member of the Commercial Food Equipment Service Association, recommends using CFESA Certified Technicians.



**24-Hour Service Hotline**  
**1-800-551-8633**

**Price: \$6.00**

**819-6044**  
**MAY 16**

**NOTICE**

IF, DURING THE WARRANTY PERIOD, THE CUSTOMER USES A PART FOR THIS ENODIS EQUIPMENT OTHER THAN AN UNMODIFIED NEW OR RECYCLED PART PURCHASED DIRECTLY FROM FRYMASTER DEAN, OR ANY OF ITS AUTHORIZED SERVICE CENTERS, AND/OR THE PART BEING USED IS MODIFIED FROM ITS ORIGINAL CONFIGURATION, THIS WARRANTY WILL BE VOID. FURTHER, FRYMASTER DEAN AND ITS AFFILIATES WILL NOT BE LIABLE FOR ANY CLAIMS, DAMAGES OR EXPENSES INCURRED BY THE CUSTOMER WHICH ARISE DIRECTLY OR INDIRECTLY, IN WHOLE OR IN PART, DUE TO THE INSTALLATION OF ANY MODIFIED PART AND/OR PART RECEIVED FROM AN UNAUTHORIZED SERVICE CENTER.

**THE CABINET IS NOT SUITABLE FOR OUTDOOR USE. WHEN OPERATING THIS UNIT, IT MUST BE PLACED ON A HORIZONTAL SURFACE.**

**THE CABINET IS NOT SUITABLE FOR INSTALLATION IN AN AREA WHERE A WATER JET CAN BE USED. THIS APPLIANCE MUST NOT BE CLEANED WITH A WATER JET.**

**FOR YOUR SAFETY**

**DO NOT STORE OR USE GASOLINE OR OTHER FLAMMABLE VAPORS AND LIQUIDS IN THE VICINITY OF THIS OR ANY OTHER APPLIANCE.**

**DO NOT OPERATE OR SERVICE THE CABINET WITHOUT FIRST READING THIS MANUAL.**

**DO NOT OPERATE THE CABINET UNLESS IT HAS BEEN PROPERLY INSTALLED AND CHECKED.**

**DO NOT OPERATE THE CABINET UNLESS ALL SERVICE AND ACCESS PANELS ARE IN PLACE AND PROPERLY SECURED.**

**DO NOT ATTEMPT TO REPAIR OR REPLACE ANY COMPONENT OF THE CABINET UNLESS ALL POWER TO THE UNIT HAS BEEN DISCONNECTED.**

**USE CAUTION WHEN SETTING UP, OPERATING, OR CLEANING THE CABINET TO AVOID CONTACT WITH HEATED SURFACES.**

# Table of Contents



<b>Theory of Operation</b>	<b>1-1</b>
<b>Service Procedures</b>	<b>2-1</b>
<b>Re-addressing Cabinet</b>	<b>3-1</b>
<b>Troubleshooting</b>	<b>4-1</b>
<b>Illustrated Parts List</b>	<b>5-1</b>
<b>Wiring Diagrams</b>	<b>6-1</b>

# Cabinet Service Procedures

## 1 Functional Description

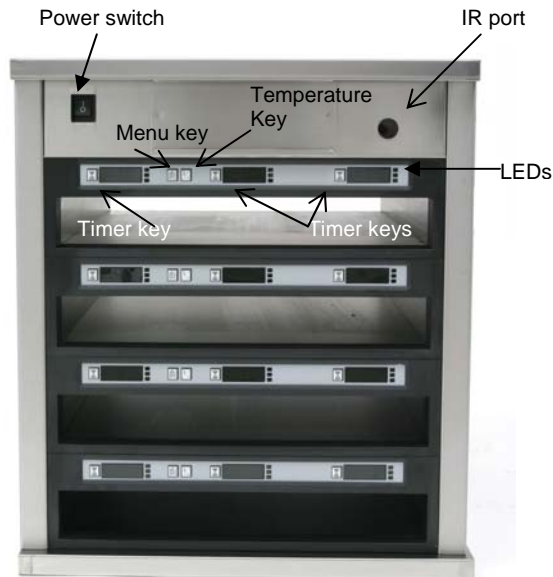

**Figure 1:** UHC-P cabinet

**NOTE:** This manual covers the UHC-P, the original PDA-programmed cabinet for McDonald's and the HCP or Holdmaster, a similar cabinet made for the general market. UHC-P parts are compatible with the HCP, except for the heater plates and bezel.

**Note:** The illustrations for these service procedures are of the 4-slot full size UHC-P. The procedures are similar for the 2-slot and the narrow models.

### 1.2 Theory of Operation

The CABINET operates on 208-250VAC 50 or 60 cycle single-phase power. The main switch activates a relay, which supplies line voltage to two distribution boards, two cooling fans and a 12-volt transformer, which supplies a power supply. The power supply provides 5VDC to the communication board and the distribution boards.

A ribbon cable connects the communication board to both distribution boards, connecting at J9. Ribbon cables, which carry 5V DC, also connect the distribution boards to the displays. The resistance of RTDs attached to the heater plates is monitored by the distribution boards. The board switches power through solid-state relays to the heater plates when the resistance, which is used as an indicator of temperature, falls out of the range for the product held in the cabinet.

The switch, transformer, communication board, cooling fans and power supply are mounted under the top of the unit. There is a small dark lens portal on the upper right side of the cabinet, which allows infrared communication between the cabinet and a Palm Pilot. The distribution boards are mounted on the left side (as viewed from the front).

The parameters for holding temperatures are transferred to the cabinet's communication board via a Palm Pilot with special CABINET software. All programming of the cabinet is done on the Palm.

# Cabinet Service Procedures

## 2 Service Procedures

**DANGER:** Failure to disconnect the power supply before servicing could result in serious injury or death. The cabinet power switch **DOES NOT** disconnect all incoming power to the cabinet.

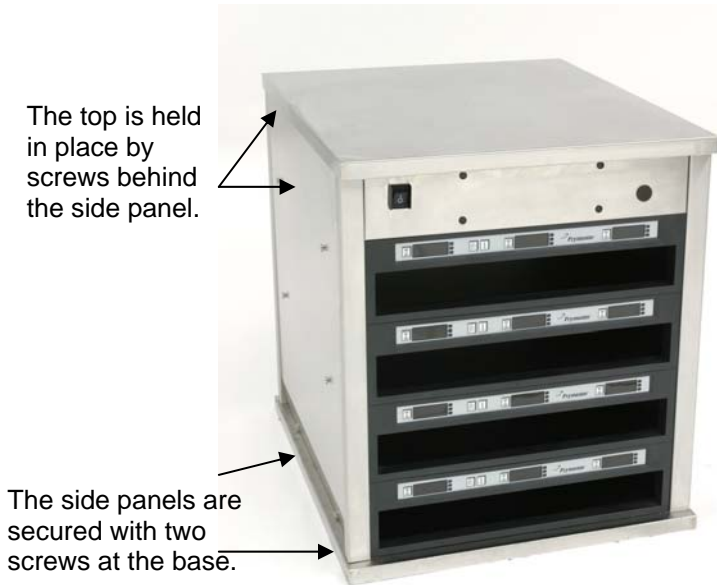

**Figure 1:** The side panels must be removed to access the component shelf.

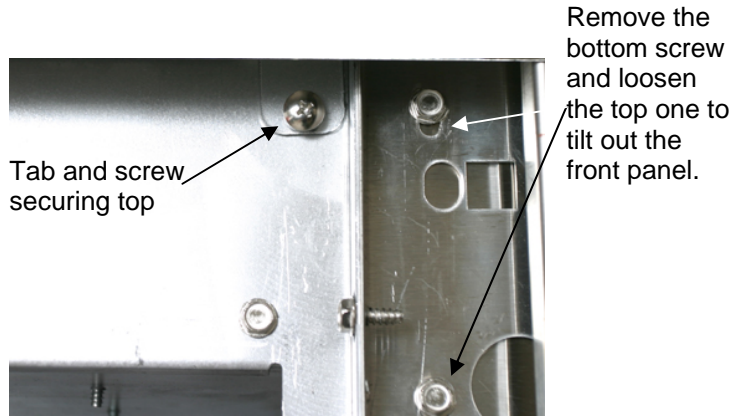

**Figure 2:** Four sheet metal tabs hold the top in place. Remove these screws at each corner and lift off the top.

### 2.1 Accessing the Electronic Components

1. The component shelf is accessed by removing two screws on each side of the unit. See **figure 1**.

2. Lift and remove the sides, which exposes screws that hold the top in place. See **figure 2**.

3. The front panel, which holds the switch and the IR lens, can be rotated forward by removing a screw on either side and loosening two others. See **figure 3**. With the removal of four more screws, the component shelf will slid forward if necessary.

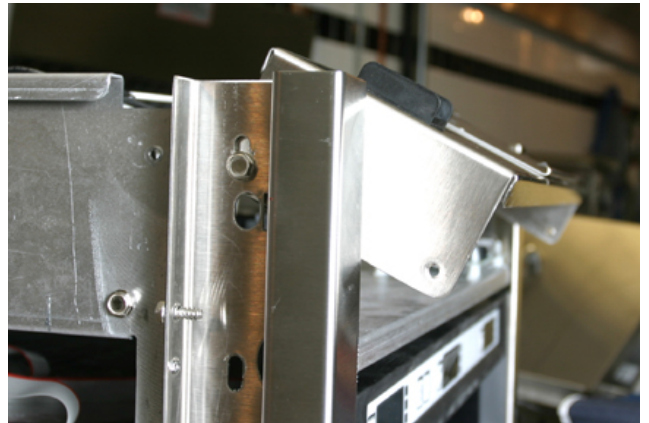

**Figure 3:** Remove the screws which secure the component shelf, allowing the shelf to be pulled forward.

# Cabinet Service Procedures

## Under the top

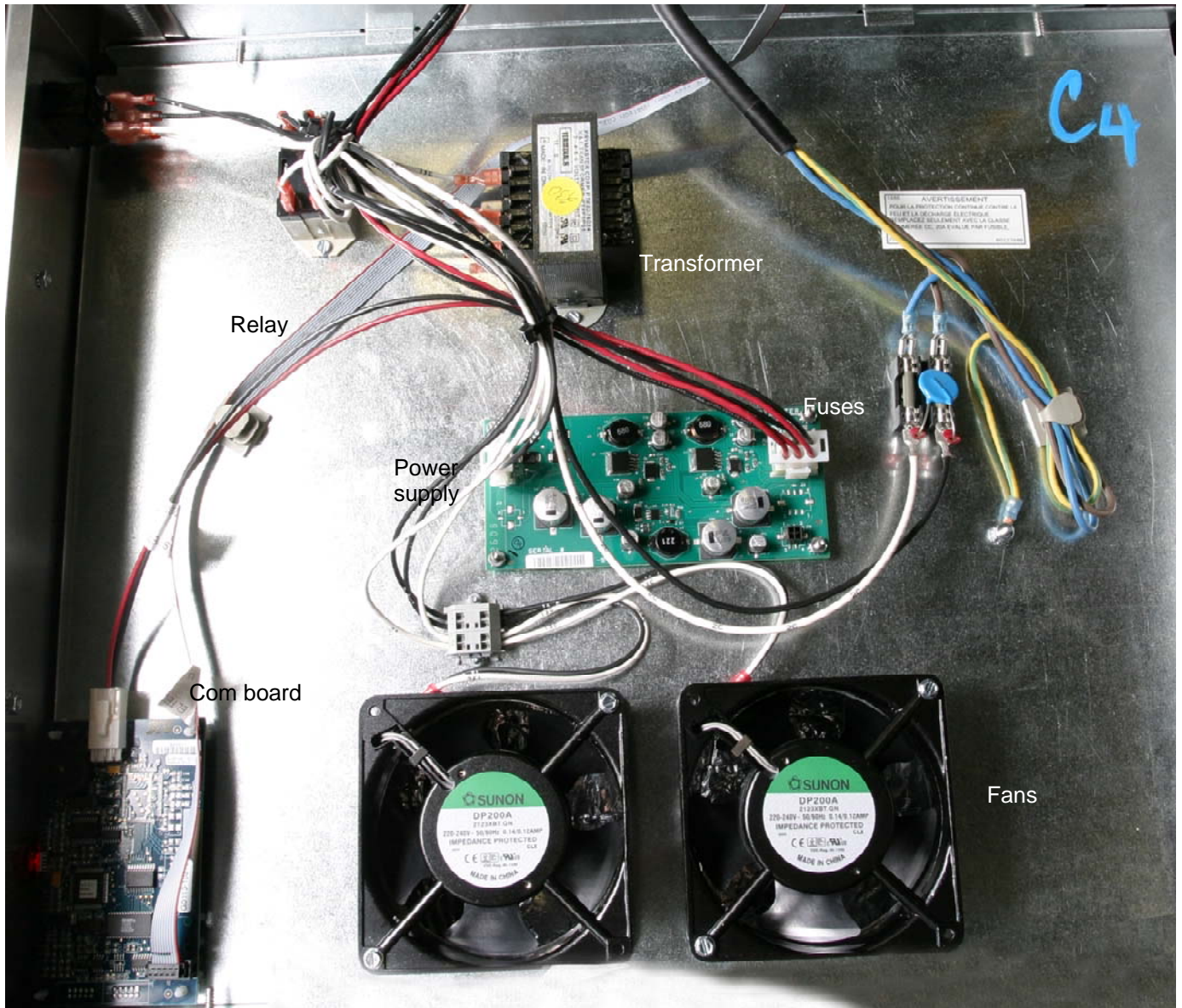

Figure 4

# Cabinet Service Procedures

All the components are readily removed. There are no replaceable components on the circuit boards. The replacement of a display, distribution or communication board will require re-addressing the cabinet, covered in Section 3.

## 2.2 Tests

### 2.2.1 Transformer

1. Disconnect power to cabinet. Remove side and top panels, unless stacked. See the service procedures for access instructions, Section 2.1
2. Check for 208VAC at the primary, 12VAC at the secondary terminals.

### 2.2.2 Power Supply

1. Disconnect power and check all terminals and connections for loose or disconnected wires.
2. Apply power and check for +5VDC at the J5 terminal on the communications board, using the center pin for the positive lead and either adjacent for the negative lead.

Sensor (°F)	Resistance	Sensor (°C)
60	106.065	15.55
70	108.224	21.11
80	110.380	26.66
90	112.532	32.22
100	114.680	37.77
110	116.825	43.33
120	118.966	48.88
130	121.104	54.44
140	123.239	60.00
150	125.369	65.55
160	127.496	71.11
170	129.620	76.66
180	131.740	82.22
190	133.856	87.77
200	135.969	93.33
210	138.078	98.88
220	140.184	104.44
230	142.286	110.00
240	144.385	115.55
250	146.480	121.11
260	148.570	126.66

### 2.2.3 RTD

1. Remove the leads from the suspect RTD and test for resistance. selected temperatures and resistances are show in Figure 7, a chart at right.

**NOTE:** After testing, reconnect all leads to their original positions.

**Figure 7:** RTD resistance chart

# Cabinet Service Procedures

## 2.2.4 Distribution Boards

1. Check for line voltage between the heater plate terminal on the board and the terminal block for the suspect heater. Note: Line voltage is only seen when the slot is calling for heat.
2. Check for line voltage between the power input terminal and the terminal block.
3. Check for +5VDC at the Power In terminal between the positive center pin and either adjacent pin.

**NOTE:** After testing, reconnect all connections to their original positions.

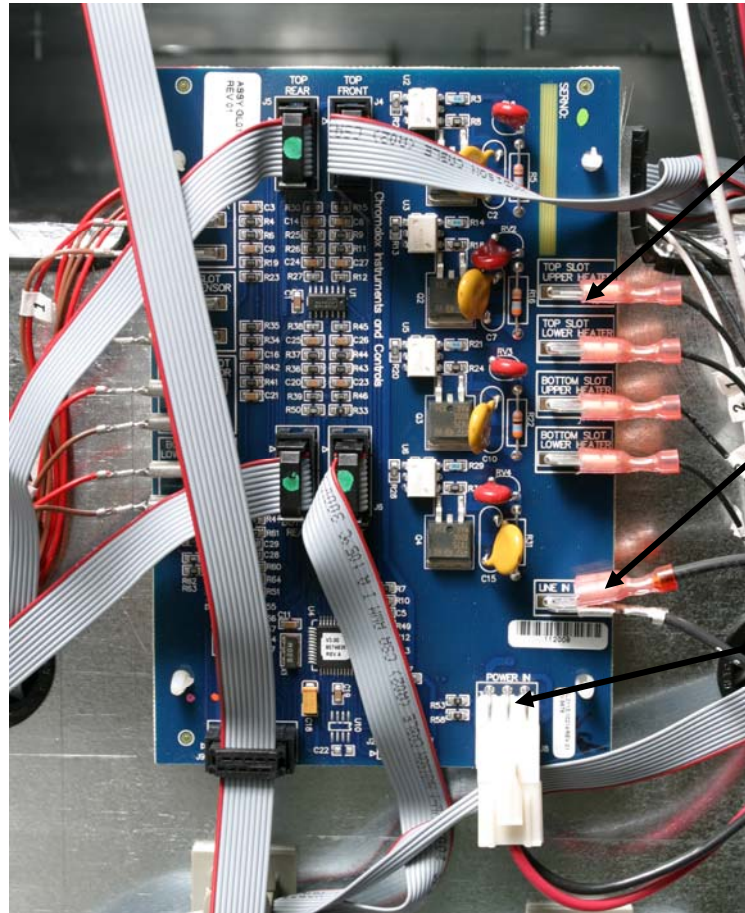

Line voltage between slot leads and common on terminal block with slot calling for heat.

Line Voltage between power input and common on terminal block.

+ 5VDC between positive center pin and either adjacent pin.

**Figure 8:** Testing distribution board.

## 2.2.5 Display

1. Connect the ribbon cable from a faulty display to the connector of a properly working display to isolate the problem to the display or the distribution board.

## 2.2.6 Shorted Triac

1. Turn the suspect slot off and measure voltage between the suspect heater lead on the distribution board and the terminal block. With the slot off, there should be no line voltage. If the triac is shorted, you will measure AC line voltage. If the triac is half waving, you will get DC voltage of approximately one-half the line AC voltage.

## 2.2.7 Calibration

Calibrate the top and bottom plates in all four UHC slots by performing the following procedure with the slots clean, empty and at operating temperature for at least 30 minutes.

1. Press the temperature key to ensure the slot is at setpoint.
2. Slide the Atkins sensor into a slot with the sensor facing up to measure the top heater plate or down to measure the bottom heater plate. Move the sensor to the center of the plate. To get an accurate reading, the sensor must be within  $\pm 1$  inch (25mm) of the center of the plate.

# Cabinet Service Procedures

3. Allow three minutes for the sensor to stabilize.
4. Read the temperature on the Atkins meter and compare to the reading from the cabinet, which is displayed by pressing the temperature key once for the top plate temperature and twice for the bottom plate. The displayed temperature should be within  $\pm 5^{\circ}\text{F}$  ( $\pm 3^{\circ}\text{C}$ ) of the meter. If the reading is out of tolerance, perform the following procedure.

Launch the UHC-P software on the Palm and follow these steps:



**Step 1:** Tap the left corner of the display in Setup or Menu mode. A menu bar is displayed.

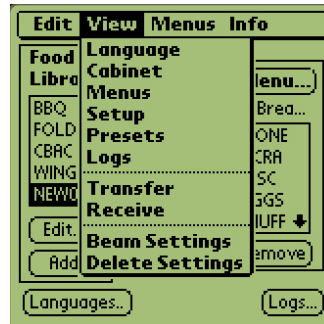

**Figure 2:** Tap View in the menu bar and tap Cabinet in the pull-down menu.



**Step 3:** The Cabinet Configuration menu is displayed. Tap the Offsets button in the left corner.



**Step 4:** The Cabinet Configuration Offset menu is displayed. The offset entry fields for the slots are arranged left to right and top to bottom

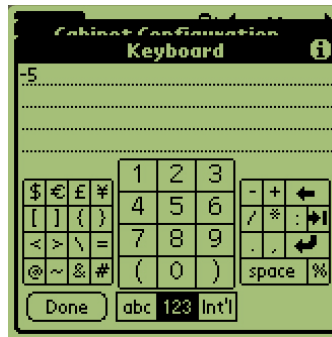

**Step 5:** Tap on the number line by the plate being offset and then the number in the bottom right of the Palm display. Use the backspace key to erase number in the field and use the keypad to enter the desired offset. See examples in Table 1 (at right). Tap Done.

Offset Entry Examples		
Display	Meter	Correction
150°F	155°F	5
150°F	145°F	-5
66°C	69°C	3
66°C	63°C	-3

**Table 1**

# Cabinet Service Procedures



**Step 6:** The entered offset is visible on the menu. In this case we offset the top slot's top heater plate  $-5^{\circ}\text{F}$ . Adjust other slots as necessary.



**Step 7:** With the Palm horizontal and approximately one foot from the receiving lens on the cabinet, tap the Transmit button. The Transfer menu will be displayed. A message will be displayed when the transfer starts and when the transfer is complete.

## 2.2.7 Heater Plate

1. Disconnect power to the cabinet. On stand-alone units, remove side and top panels. On stacked units, see Service Procedures for instructions on accessing the top panel.
2. Disconnect the black heater lead and the two RTD leads (brown and red) of the suspect plate from distribution board. Measure resistance of the heater from the black lead to any terminal on the white terminal block. Resistance should be 140-150 ohms.
3. Measure resistance across the brown and red RTD leads. Resistance must be within a range of 104-148 ohms. Resistance at room temperature is approximately 107 ohms. See chart on **Page 2-3** for resistance at different temperatures. If either resistance is incorrect, replace the heater plate.

## 2.2.8 Display Meanings

1. SLOT TEMP HIGH OR SLOT TEMP LOW and no audible alarm. This is normal when the slot is changing temperature in association with a menu change.
2. LLLL means the RTD indicates a temperature below  $50^{\circ}\text{F}$  ( $10^{\circ}\text{C}$ ). Unit will automatically heat at 20 percent until temperature is above  $50^{\circ}\text{F}$  ( $10^{\circ}\text{C}$ ), then operate normally.
3. HHHH means RTD indicates the temperature is above  $255^{\circ}\text{F}$  ( $124^{\circ}\text{C}$ ), but below "Open" circuit resistance, which causes SENS ALARM.

UHC VERSION \_ \_ \_ (version number will vary) appears for five seconds when the unit is turned on.

# Cabinet Service Procedures

## 2.3 Removing/Replacing Components

1. The bezel holding the controller display is secured in the cabinet by two allen and two hex-head screws.

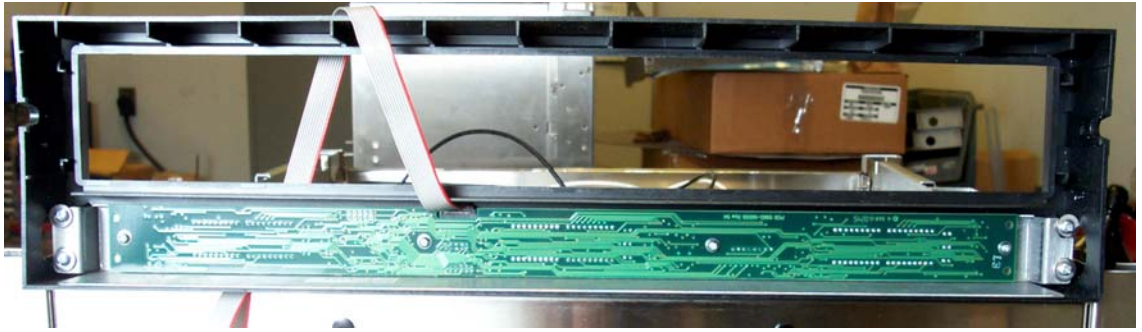

**Figure 9:** The bezel holding the display is shown removed.

Four screws secure the display in the bezel. The ribbon cable attaches to the distribution board on the side of the unit.

2. A baffle (**Figure 10**) is behind the display and it must be removed to feed the ribbon cable

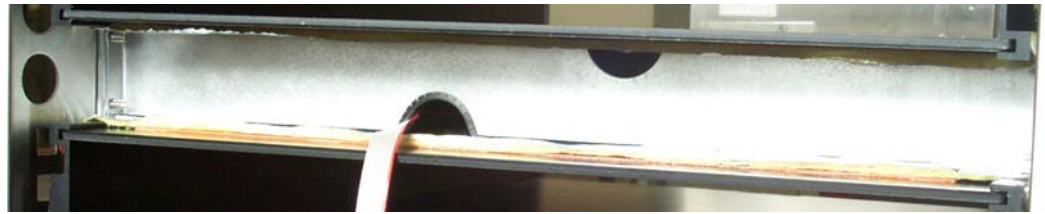

**Figure 10:** A baffle is secured behind the bezel.

from a new display through the cabinet framework to the distribution board.

3. After replacing a display, the cabinet must be re-addressed. See Section 3.

### 2.3. 1 Removing/Replacing a Distribution Board or Communication Board

1. Remove and mark the wires on the faulty component.
2. Remove the board by lifting it from its standoffs.
3. Rewire the board.
4. After replacement of a communication, display or distribution board, the cabinet must be re-addressed, which is covered in Section 3.

### 2.3.2 Removing a Slot



2-7 **Figure 11:** A faulty slot is slipped from the cabinet.

# Cabinet Service Procedures

1. Perform steps in Section 2-1. Disconnect the faulty slot from the distribution board, and terminal block.
2. Loosen, but do not remove, the screws from each corner of the slot to be removed.
3. Remove wire wraps from wiring harness holding heater and control wires for affected slot.
4. Lifting slightly, carefully slide the malfunctioning slot out of the cabinet. Do not allow the slot to contact or damage the controls of the unit below (**Fig 11**).

## 2.3.3 Replace Heater Plate/RTD

1. Perform Sections 2-1, 2.3.2
2. Run your fingers around the outside surface of the slot assembly. There are four raised areas. These are the setscrews, which hold the heater plate to the spacer. Punch 4 holes in the insulation, directly above the location of the setscrews (**Fig. 12**).
3. Use an allen wrench to loosen the four spacer-setscrews along the edges of the plate (**Fig. 12**).
4. Slide the malfunctioning plate out of the spacer (**Fig. 13**).
5. Slide the replacement plate into position. Make sure the plate is inserted squarely.



**Figure 13:** The heater plate slides from the insulation.

### CAUTION

**Ensure the heater plate setscrews are tightened securely to the spacer. Tightening the setscrews will ensure the plate is properly grounded.**

# Cabinet Service Procedures

## 1.3 Start Up Indicators and Test Points

Upon startup, the communication board beeps. On the distribution boards, an LED flashes rapidly for a few seconds and then slows to one flash every two seconds. The displays will show the version number of the cabinet's firmware and then the slot's status.

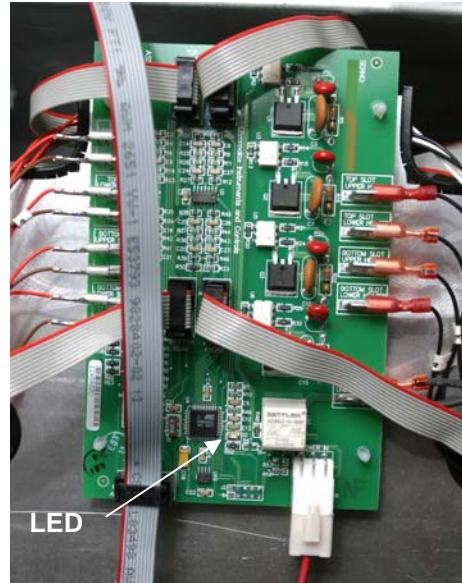

# Cabinet Service Procedures

## 3.1 Re-addressing the Cabinet

If any board or display is changed on the CABINET, the unit must be re-addressed. This essentially tells each board which position it occupies. The cabinet must also be re-programmed with the Palm. Changing the power supply doesn't require re-addressing or programming. (**Note:** Re-addressing a Narrow unit is slightly different and a separate button-push sequence is provided below.)

The process of re-addressing begins with the Palm. The security level has to be changed to **admin** in the Palm software to access the re-address feature. The cabinet must be ON. Follow these steps to re-address the cabinet with the Palm.

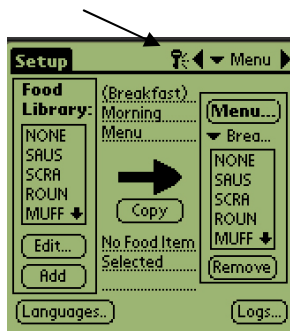

**Step 1:** Tap the key icon at the top of the screen (see arrow) to access the security manager.



**Step 2:** Use the Palm's keyboard feature (see arrow), to type **admin** in the security manager dialog box. Tap OK.



**Step 3:** A dialog box appears, saying the security level has been changed. Tap OK.

**NOTE:** The cursor must be in the blank line of the dialog box to access the keyboard.

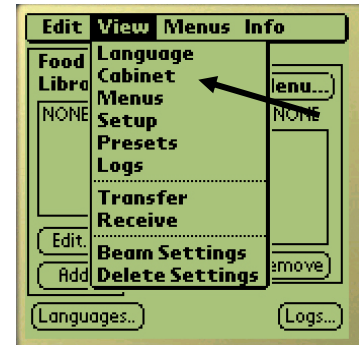

**Step 4:** Tap the Setup bar in the top left to reveal the menu bar. Tap View and in the drop-down menu highlight Cabinet by tapping it.

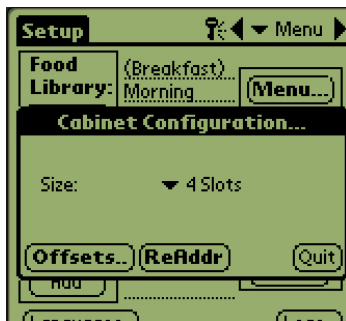

**Step 5:** The Cabinet Configuration screen is displayed. Make sure that the proper slot size is displayed ( 2 slots, 4 slots, narrow). (**NOTE:** The button-push sequence for the Narrow unit is different and covered in Steps 7N-14N on the adjoining page.) With the Palm horizontal and near the lens on the UHC-P cabinet, tap the ReAddr button in the bottom center of the screen.

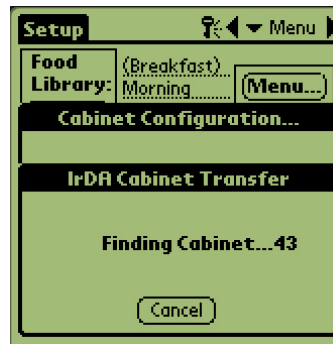

**Step 6:** The addresses of the cabinet's boards will be beamed to the cabinet. A success message will display when the process is complete. Press 1 Button will be displayed on each slot.

**\*NOTE:** Failure to press the button in less than 30 seconds will cause the cabinet to react slowly to button pushes. Repeat readdress sequence to eliminate delay.

### Button-Push Sequence for 4, 2-slot Units

**Step 7:** Press and release the right timer key on the top slot on front of the unit.

**Step 8:** Repeat for second, third and fourth (if present) slots.

**Step 9:** Move to the back of the unit and press the left top slot timer key.

**Step 10:** Repeat for second, third and fourth slots.

**Step 11:** \*Press the back bottom left timer button a second time within 30 seconds of the previous button push.

**Step 12:** Press temperature key on top front slot. Verify temperature display and repeat steps for remaining slots.

**Step 13:** Repeat step 12 on back displays if present.

**Step 14:** Repeat readdress sequence if temperature displays fail.

## Cabinet Troubleshooting

Symptom	Possible Causes	Tests
Unit fails to power up; fans don't run.	<ul style="list-style-type: none"> <li>• No power to cord.</li> <li>• Blown 20 amp fuse.</li> </ul>	<ul style="list-style-type: none"> <li>• Check for line voltage at the switch and the transformer.</li> </ul>
Unit powers up and fans run; a display fails to light.	<ul style="list-style-type: none"> <li>• Broken or improperly seated ribbon cable.</li> <li>• Defective display.</li> </ul>	<ul style="list-style-type: none"> <li>• Switch ribbon cable from functioning display to failed component to isolate problem.</li> </ul>
Unit powers up and fans run; all displays fail to light.	<ul style="list-style-type: none"> <li>• Failed transformer.</li> <li>• Failed power supply.</li> </ul>	<ul style="list-style-type: none"> <li>• Check for 12VAC at transformer.</li> <li>• Check for 5VDC at communication board and distribution boards.</li> </ul>
Slots heat improperly or not at all.	<ul style="list-style-type: none"> <li>• Improper wiring on distribution board.</li> <li>• Defective distribution board.</li> <li>• Defective heater.</li> <li>• Defective sensor.</li> </ul>	<ul style="list-style-type: none"> <li>• Ensure heater leads and power inputs on the distribution boards are properly seated.</li> <li>• Test for 208VAC input on distribution board and 208VAC output from heater leads to heater plate when the unit is calling for heat.</li> <li>• Switch power leads from properly operating slot to faulty slot to isolate problem.</li> <li>• Check resistance of RTD lead against temperature chart. See Page 2-3.</li> <li>• Switch RTD lead from properly operating slot to faulty slot to isolate problem.</li> <li>• Test continuity of heater plate.</li> </ul>
Cabinet beeps continuously.	<ul style="list-style-type: none"> <li>• Stuck display button.</li> <li>• Defective display.</li> <li>• Shorted capacitor on one or more display.</li> <li>• Bad communication board.</li> </ul>	<ul style="list-style-type: none"> <li>• With power applied, unplug each display, one at a time, to isolate beeping. Replace beeping display.</li> <li>• Beeping continues? Replace communications board.</li> </ul>

## Cabinet Troubleshooting

Unit locks up; buttons won't respond.	<ul style="list-style-type: none"><li>• Cabinet not readdressed.</li></ul>	<ul style="list-style-type: none"><li>• Readdress cabinet.</li></ul>
Display shows Off or Clean Mode only.	<ul style="list-style-type: none"><li>• Cabinet not reprogrammed after readdressing.</li></ul>	<ul style="list-style-type: none"><li>• Reprogram cabinet.</li></ul>
After brief operation, all displays dim except countdown.	<ul style="list-style-type: none"><li>• Failed transformer.</li></ul>	<ul style="list-style-type: none"><li>• Check for 12VAC at transformer.</li></ul>

# Cabinet Service Procedures

## Button-Push Sequence for Narrow Unit

**Step 7N:** Press and release the top front timer key.

**Step 8N:** Repeat for second, third and fourth slots.

**Step 9N:** Move to the back of the unit and press the top **temperature** key.

**Step 10N:** Repeat for second, third and fourth slots.

**Step 11N:** \*Press the back bottom **timer** key within 30 seconds of the previous **temperature** key push.

**Step 12N:** Press temperature key on top front slot. Verify temperature display and repeat steps for remaining slots.

**Step 13N:** Repeat step 12 on back displays if present.

**Step 14N:** Repeat readdress sequence if temperature displays fail.

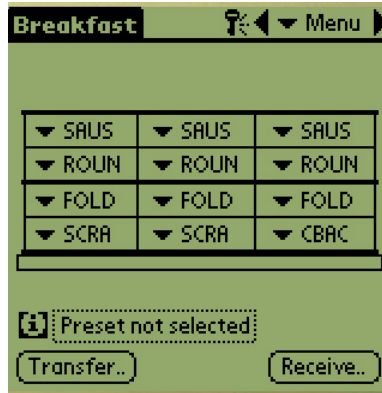

**Step 15:** Beam over the cabinet configurations with a Palm, which holds the restaurant's desired cabinet configurations by opening the UHC-P software to the setup window.

**NOTE:** It is not necessary to beam menus separately. All menus in the Palm — the displayed menu and all others — are moved to the cabinet with each transfer.

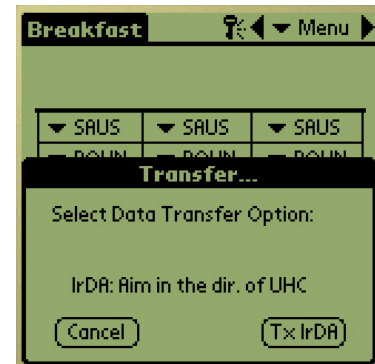

**Step 16:** Ensure the dark receiving lens on the front of the cabinet is clean. Hold the Palm Pilot parallel with the floor and aim it at the lens from no more than one foot away.

Tap the Transfer button.

Tap the TxirDa button.

The cabinet will beep and the Palm Pilot will display a message, indicating a successful transfer. \*All five menus established on the Palm are now accessible with the menu key on the cabinet. Note: Text on buttons can vary between software versions.

**\*NOTE:** Failure to press the button in less than 30 seconds will cause the cabinet to react slowly to button pushes. Repeat readdress sequence to eliminate delay.

# Cabinet Parts

**NOTE:** This manual covers the UHC-P, the original PDA-programmed cabinet for McDonald's and the HCP or Holdmaster, a similar cabinet made for the general market. UHC-P parts are compatible with the HCP, except for the heater plates and bezel.

## 5 Parts Lists, Exploded Views

### 5.1 Cabinet Components

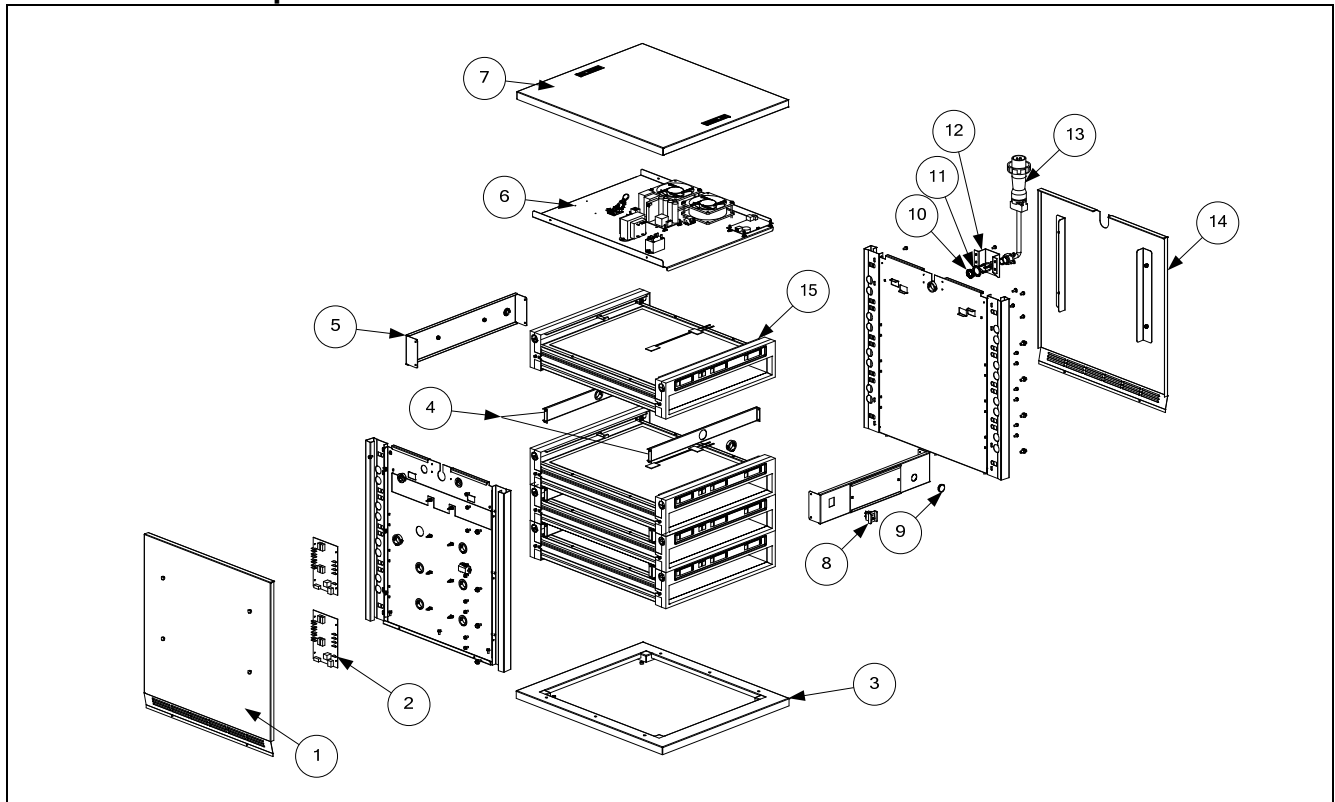

Item	4- Slot Part #	2-Slot	Narrow	Description
1	210-3659	210-3710	210-3659	Left Side Cabinet
2	826-2644	826-2644	826-2644	Distribution board
3	806-7904SP	806-7904SP	106-4549	Base
4	106-4571	106-4571	N/A	Bracket Assembly, UHCII Insulator
5	106-4225	106-4225	106-4547	Rear Fascia Assembly <b>without</b> Menu.
6				Component shelf, See page 5-2
*	809-0256	809-0256	809-0256	Button Hanger Nut
7	806-7906SP	806-7906SP	106-4544SP	Top Cap Assembly
8	807-4036	807-4036	807-4036	ON/OFF Switch
9	816-0634	816-0634	816-0634	Communications port cover
10	809-0581	809-0581	809-0581	Nut, 1/2 N.P.T. Locking
11	809-0582	809-0582	809-0582	Washer, 1/2 N.P.T. Star-Lock
12	200-3639	200-3639	200-3639	UHC Cordset Bracket
13	807-2473	807-2473	807-2473	Pin & Sleeve Cordset with Strain Relief 8073238 and washer.
*	807-2474	807-2474	807-2474	Cordset, Twist Lock Power Cord ( <b>HC-P</b> )
*	807-4409	807-4409	807-4409	UHC-P Cordset, includes strain relief (China)
14	910-4876	910-9452	910-4876	Right Side Cabinet Assembly
15				Slot assemblies, see page 5-3
*	807-2766	807-2766	807-2766	Power Line Filter, CE only
*	826-2945	826-2945	826-2945	Communication kit: microcomputer, software, dongle, domestic

# Cabinet Parts

Item	4- Slot Part #	2-Slot	Narrow	Description
*	826-2946	826-2946	826-2946	Communication kit: microcomputer, software, dongle, export
*	826-3060	826-3060	826-3060	Communications software only
*	826-3070	826-3070	826-3070	Software, dongle only
*	807-5264	807-5264	807-5264	Dongle only

## 5.2 UHC-P/HCP Component Shelf

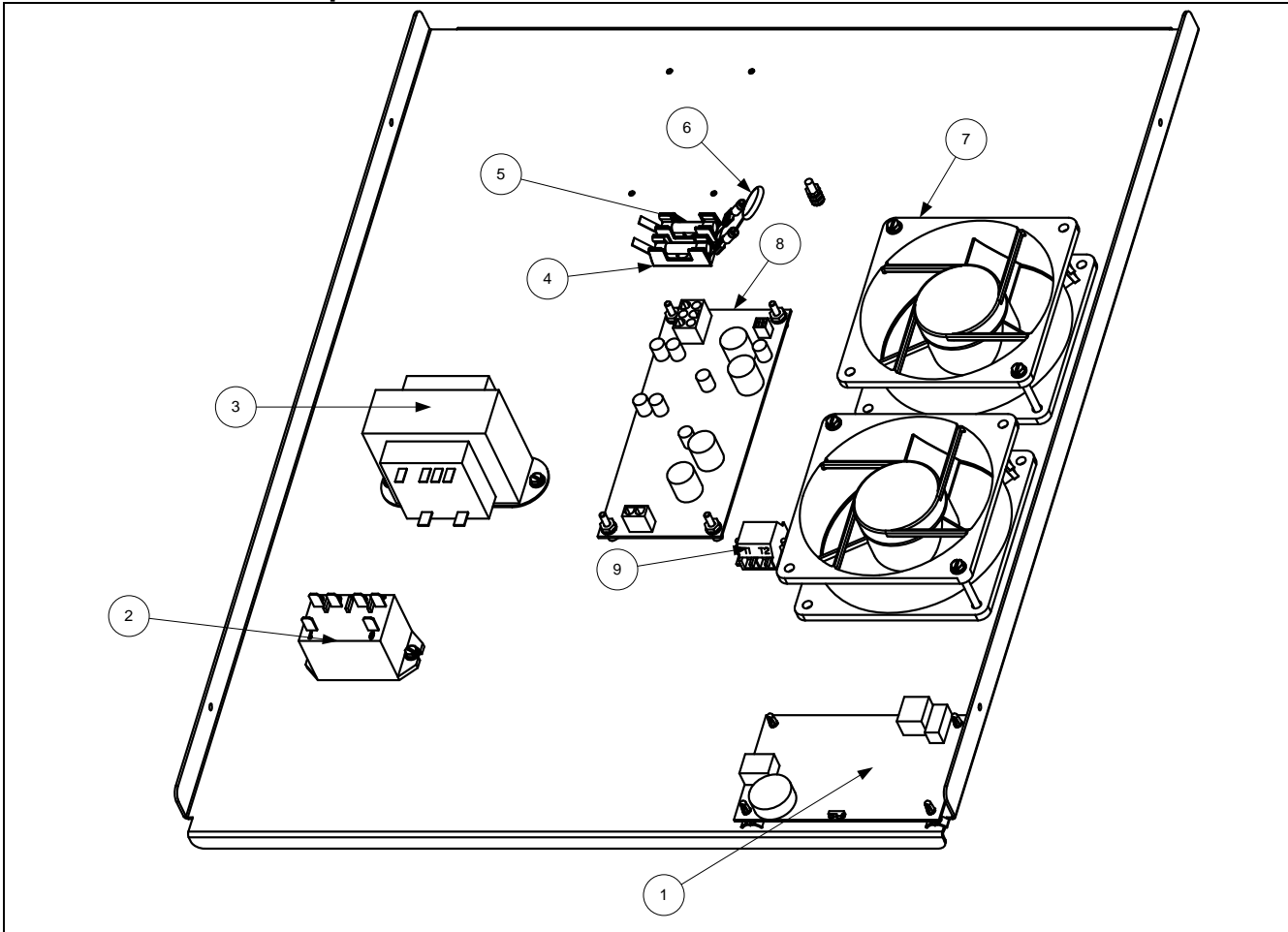

Item	4-slot Part #	2-Slot	Narrow	Description
1	826-2590	826-2590	826-2590	Board, UHC-P/HCP Communications Board
2	807-3490	807-3490	807-3490	Relay, Omron Power
3	807-4024	807-4024	807-4024	Transformer, 208-240/12V 60VA
4	807-2820	807-2820	807-2820	Block, Fuse Omni-Blok
5	807-2819	807-2819	807-2819	Fuse, 3AB-314 20 amp
6	812-1306	812-1306	812-1306	Metal Oxide Varistor
7	807-2665	807-2665	807-2665	Blower, Exhaust
8	106-9516	106-9516	106-9516	Power Supply
9	810-1164	810-1164	810-1164	Block, I Plc Screwless Terminal
*	807-3918	807-4071	807-3918	Ribbon Cable, Communications for UCH-P/HCP

\*Not Illustrated

# Cabinet Parts

## 5.3 Slot Assembly

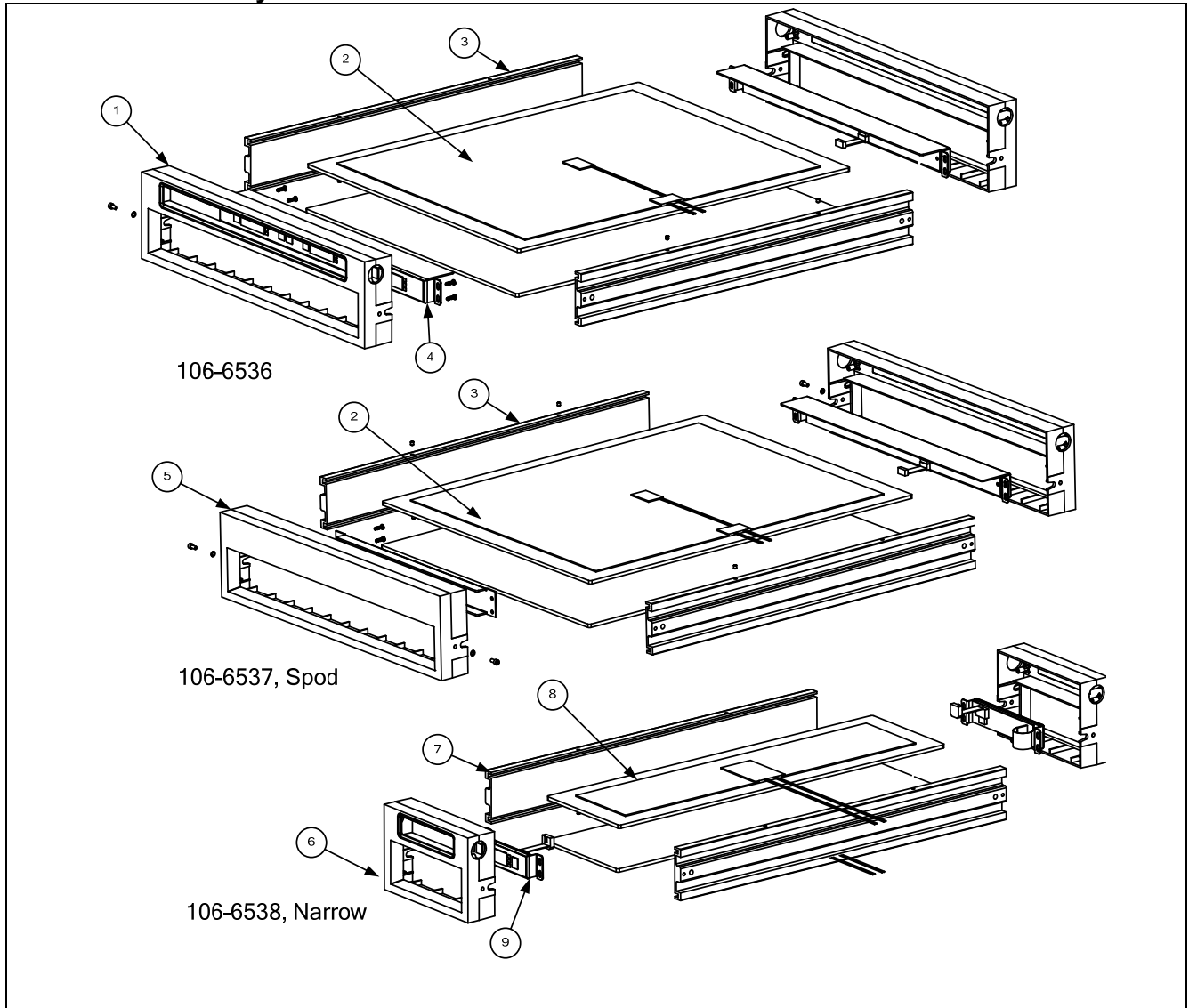

Item	Part Number	Description
1	816-0584	Bezel
*	816-0714	Bezel, HCP
2	812-1814	Heater plate
*	106-6577	Heater plate, HCP
3	810-1286	Spacer, extruded
4	826-2588	Display
*	826-3202	Membrane only kit (adhesive-backed, attaches to cleaned existing frame)
5	816-0572	Bezel, Spod
6	816-0649	Bezel, narrow
7	810-1286	Spacer, extruded
8	807-4065	Heater plate, narrow
9	807-4681	Display, narrow
*	803-0370	Wire Rack for 816-0726 ( <b>HCP Non-McDonald's Only</b> )
*	816-0727	High-side tray, ( <b>HCP Non-McDonald's Only</b> )
*	816-0726	Low-side tray, ( <b>HCP Non-McDonald's Only</b> )

# Cabinet Wiring Diagrams

## 6 Wiring Diagram, UHC-P

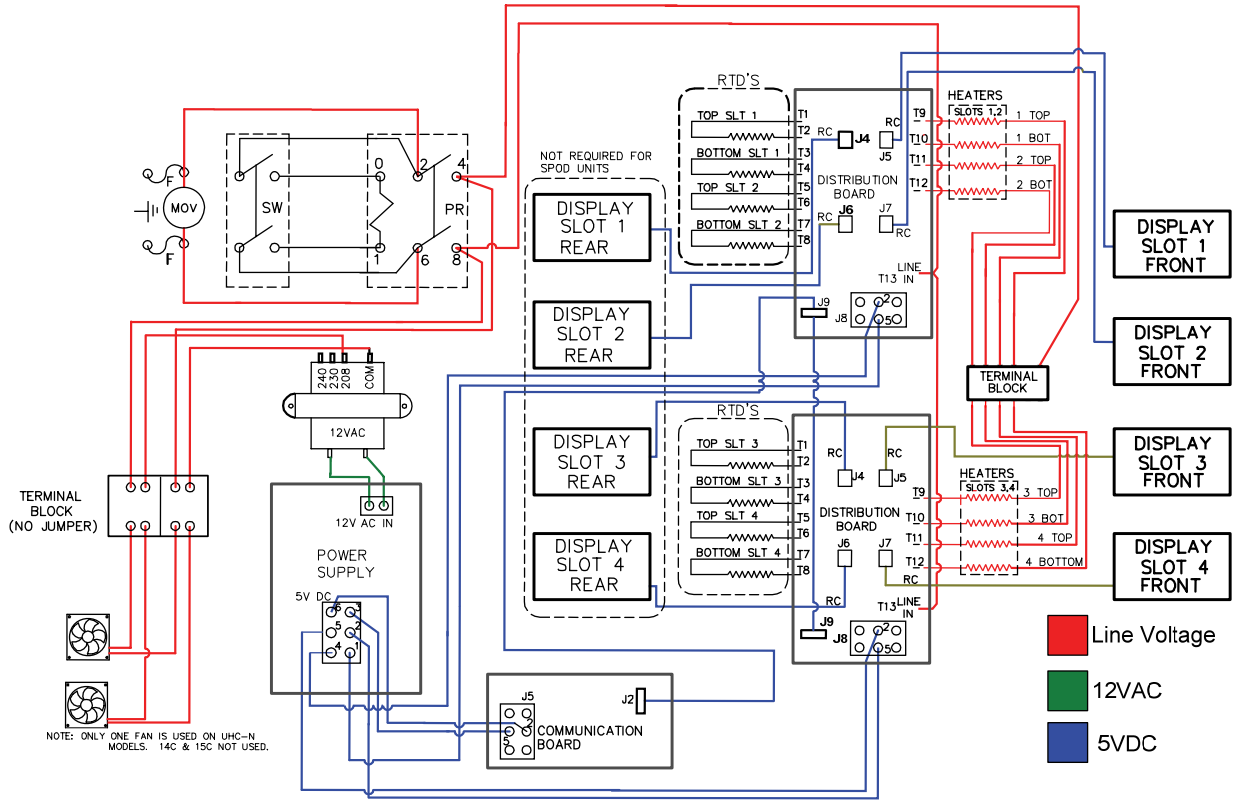

UHC-P 4 Slot Wiring Diagram

### 6.1 Simplified Wiring Diagram

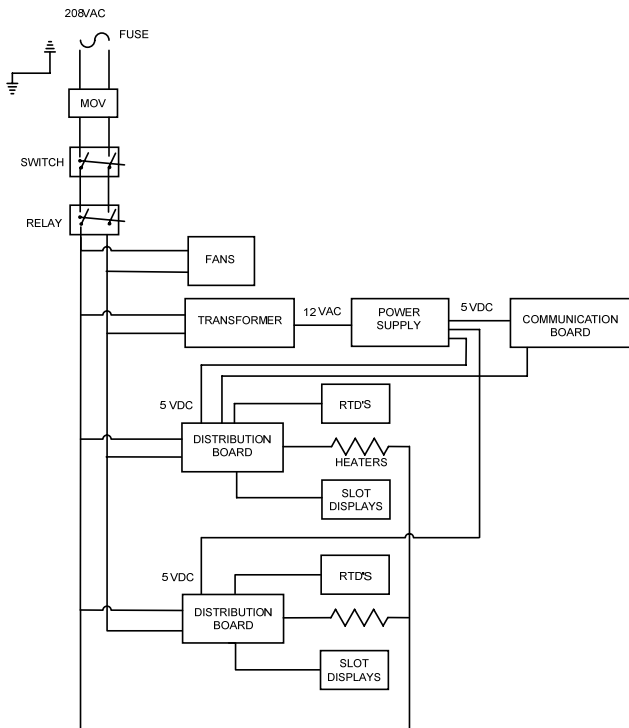

# Cabinet Wiring Diagrams

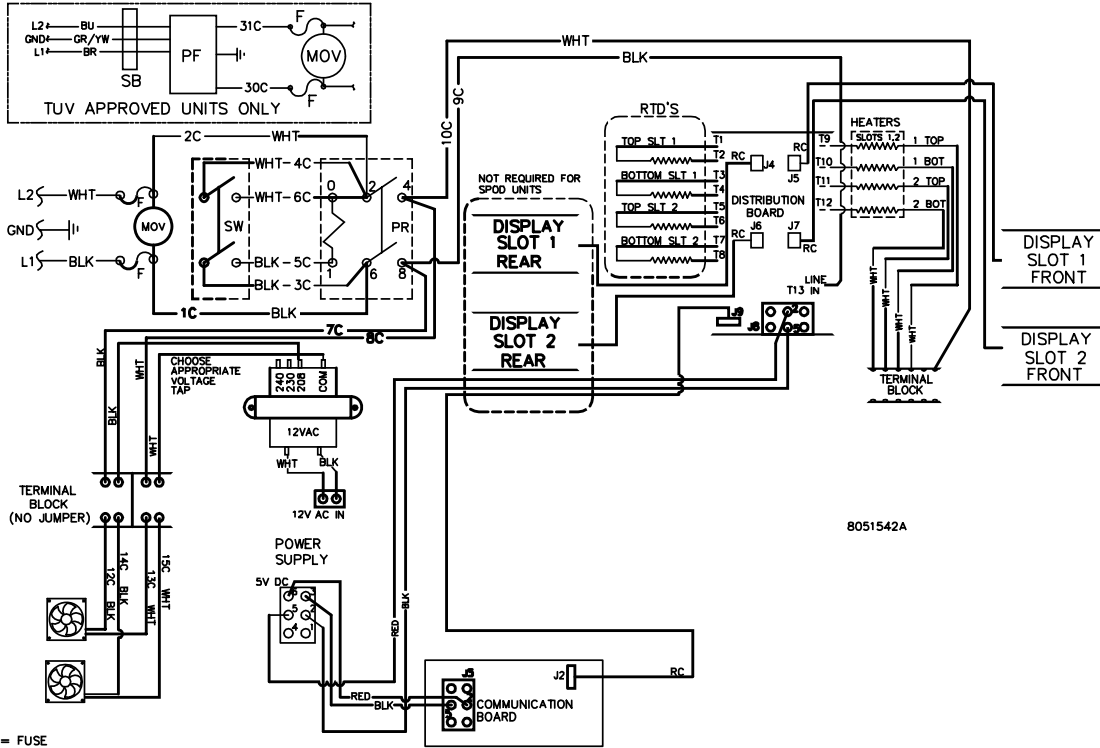

F= FUSE  
 MOV= VARISTOR, METAL OXIDE  
 RC= 10 PIN RIBBON CABLE

UHC-P 2-slot wiring diagram

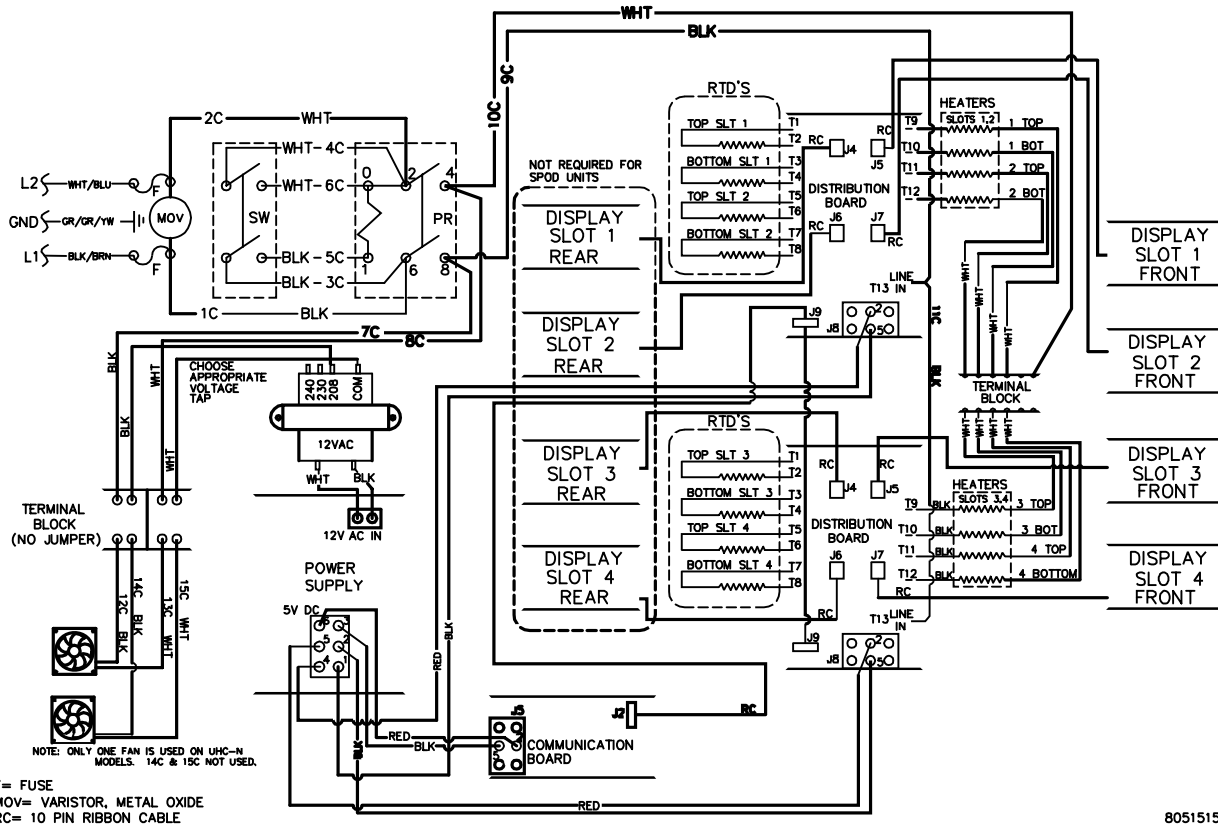

F= FUSE  
 MOV= VARISTOR, METAL OXIDE  
 RC= 10 PIN RIBBON CABLE

UHC-P N Wiring

# Cabinet Wiring Diagrams

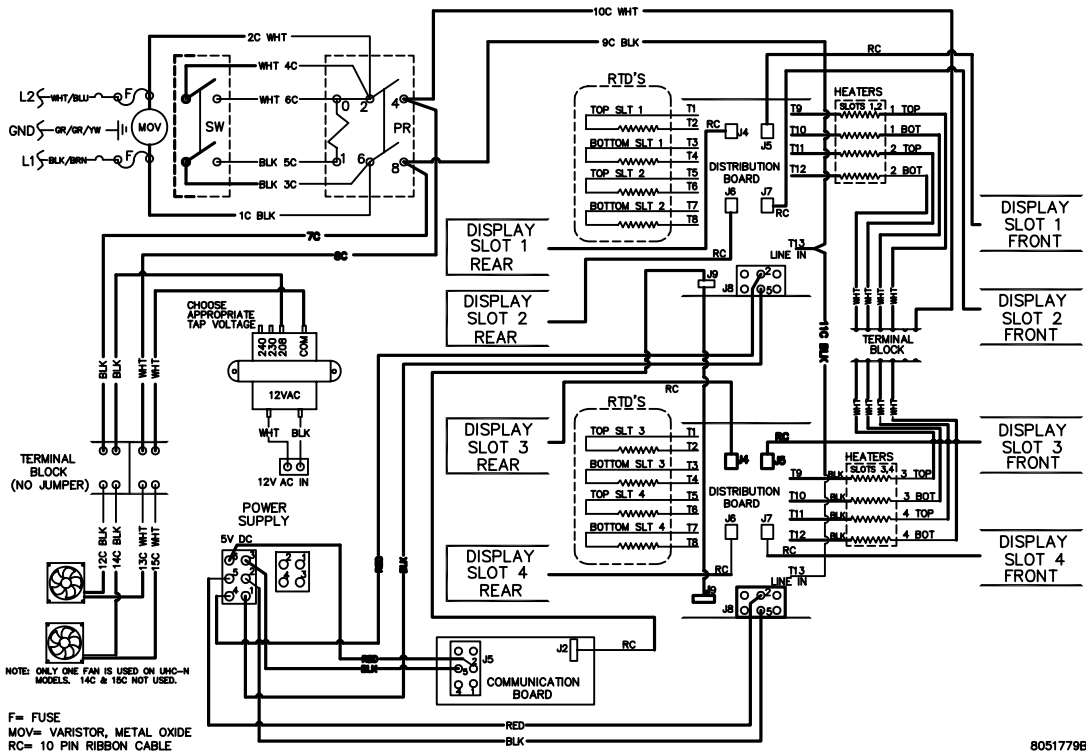

HCP wiring diagram



Frymaster, L.L.C., 8700 Line Avenue, Shreveport, Louisiana 71106

TEL 1-318-865-1711 FAX (Parts) 1-318-219-7140 FAX (Tech Support) 1-318-219-7135

PRINTED IN THE UNITED STATES

SERVICE HOTLINE  
1-800-551-8633

Price: \$6.00  
819-6044  
MAY 16