

# *Frymaster*<sup>®</sup>

*Your Growth Is Our Goal*

## OCF30™ (FPEL)

### Electric Fryer

## Wiring Diagrams

This manual is updated as new information and models are released. Visit our website for the latest manual.



8 1 9 7 2 2 4  
Part Number: FRY\_D\_8197224 10/2023



 **DANGER**

Prior to movement, testing, maintenance and any repair on your Frymaster fryer, disconnect ALL electrical power from the fryer.

# OCF30™ SERIES ELECTRIC FRYER

## Table of Contents

---

### SECTION 1: Wiring Diagrams

1.1	Simplified OCF30 Wiring with 3000 controller.....	1-1
1.2	Component Wiring Domestic and Export with 3000 controller .....	1-2
1.3	Component Wiring CE with 3000 controller.....	1-3
1.4	Component Wiring with 3000 controller 120V/480V .....	1-6
1.5	Component Wiring with CM3.5 controller Domestic and Export .....	1-7
1.6	Component Wiring with CM3.5 controller CE ( <i>Prior to 03/2015</i> ).....	1-8
1.6.1	Component Wiring with CM3.5 controller CE ( <i>After 02/2015</i> ).....	1-10
1.7	Component Wiring with Bulk Oil .....	1-11
1.8	Bulk Oil Wiring Box .....	1-12
1.9	Contactor Box-Delta Configuration .....	1-13
1.10	Contactor Box-WYE Configuration.....	1-14
1.11	Solid Shortening .....	1-15
1.11.1	Solid Shortening Control Wiring 240V .....	1-15
1.11.1.2	Solid Shortening Control Wiring 120V .....	1-16
1.11.2	Solid Shortening Component Wiring 120V/480V .....	1-17
1.11.3	Solid Shortening Component Wiring 240V .....	1-18
1.12	Basket Lift.....	1-19
1.12.1	Modular Basket Lift Wiring Diagram 208V-250V ( <i>After Mar. 2002</i> ) .....	1-19
1.12.2	Modular Basket Lift Wiring Diagram 100V-120V ( <i>After June 2006</i> ) .....	1-20
1.12.3	Modular Basket Lift Wiring Diagram 480V ( <i>After Jan. 2013</i> ).....	1-21
1.12.4	Modular Basket Lift Wiring Diagram 200V-250V ( <i>After Feb. 2013</i> ) .....	1-22
1.13	Terminal Block Wiring.....	1-23

# OCF30™ SERIES ELECTRIC FRYERS

## SECTION 1: WIRING DIAGRAMS

### 1.1 OCF30™ Series Simplified Wiring with 3000 Controller

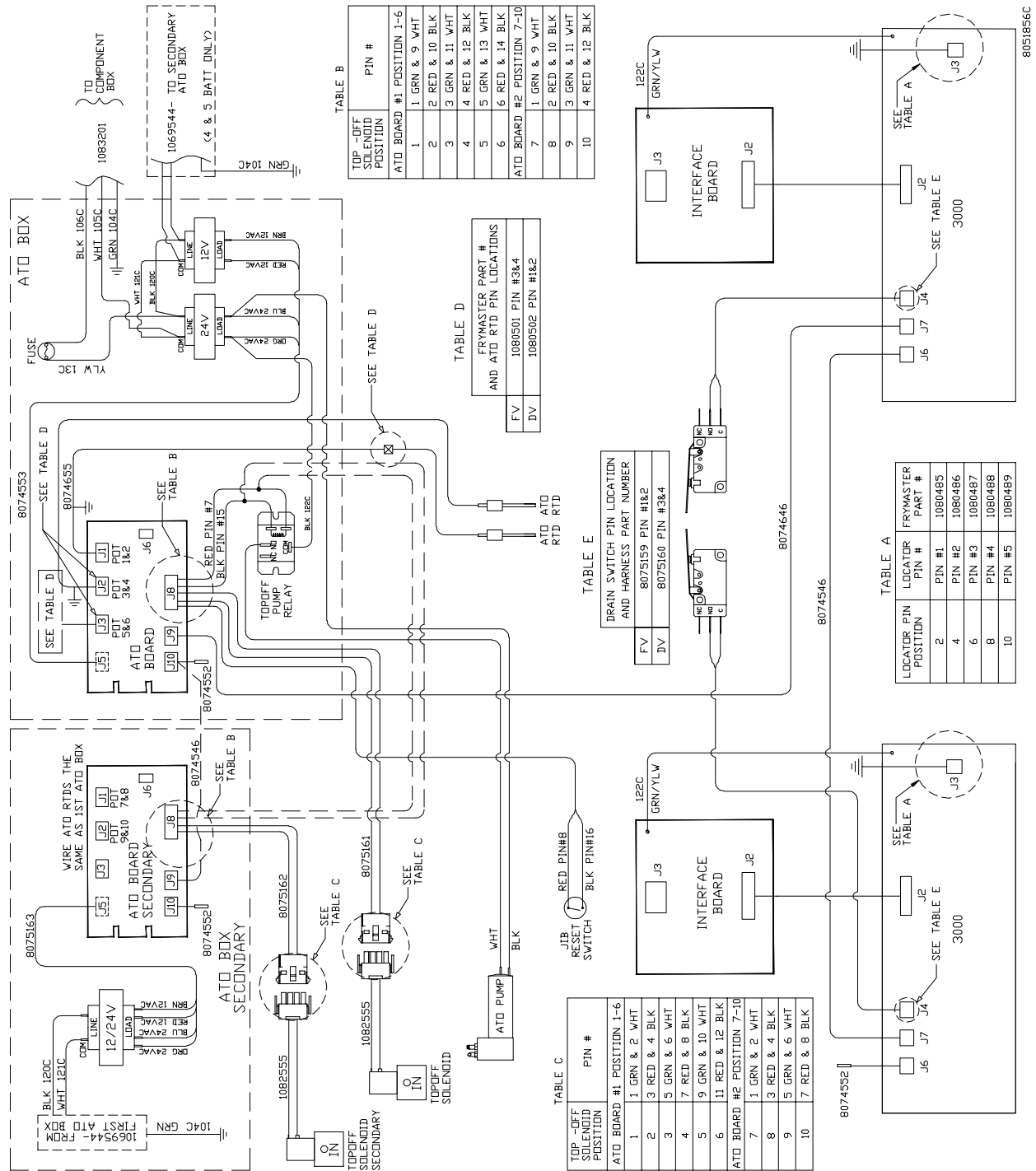

**NOTE:** If the fryer does not have the optional auto top off feature, an ATO board will not be present. The controllers will terminate on the far left and far right controller.

# 1.2 Component Wiring with 3000 Controller (Domestic and Export)

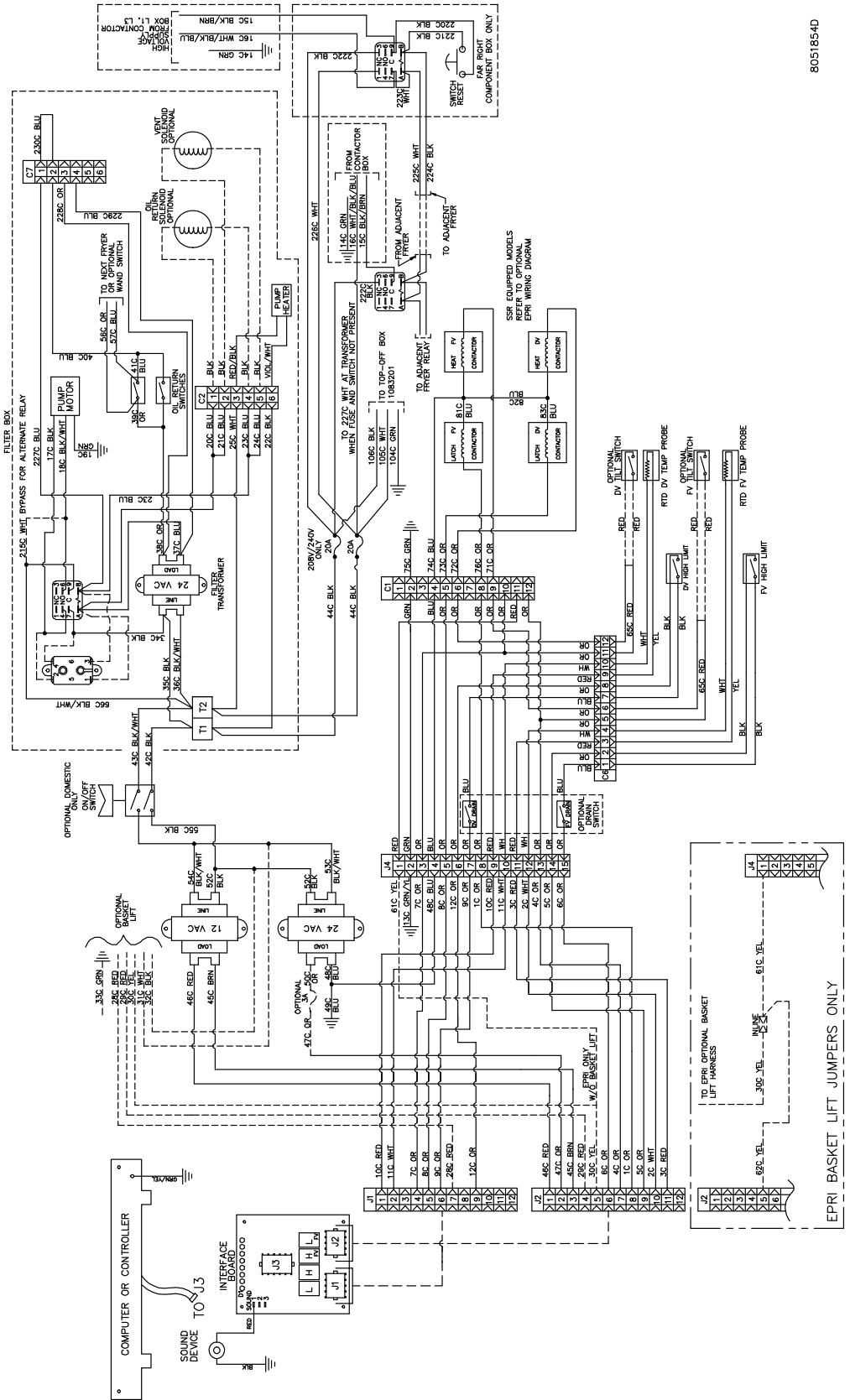

8051854D

# 1.3 Component Wiring with 3000 controller (CE) page 1

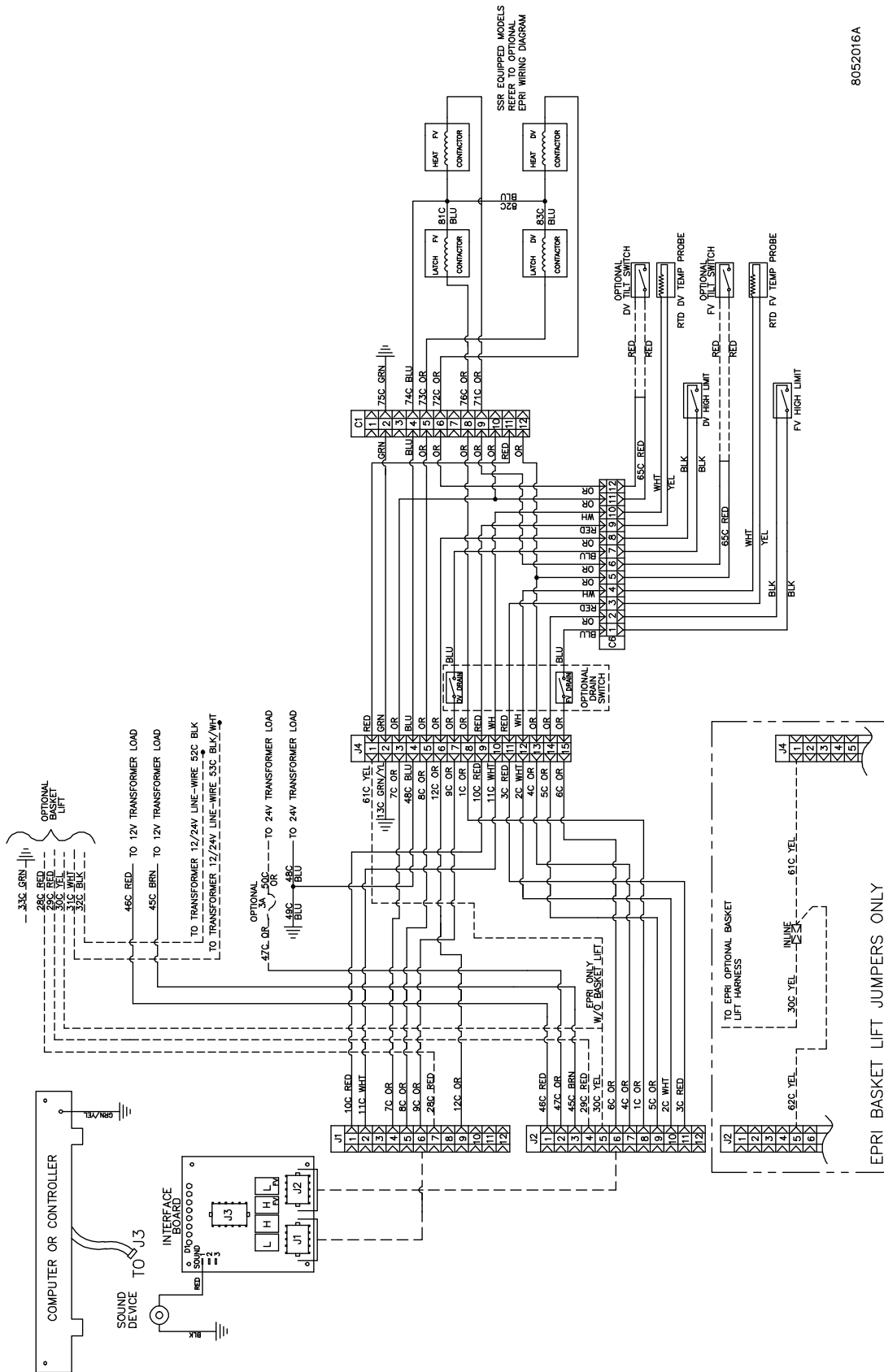

8052016A









# 1.6 Component Wiring with CM3.5 Controller (CE) page 1 (Prior to 03/2015)

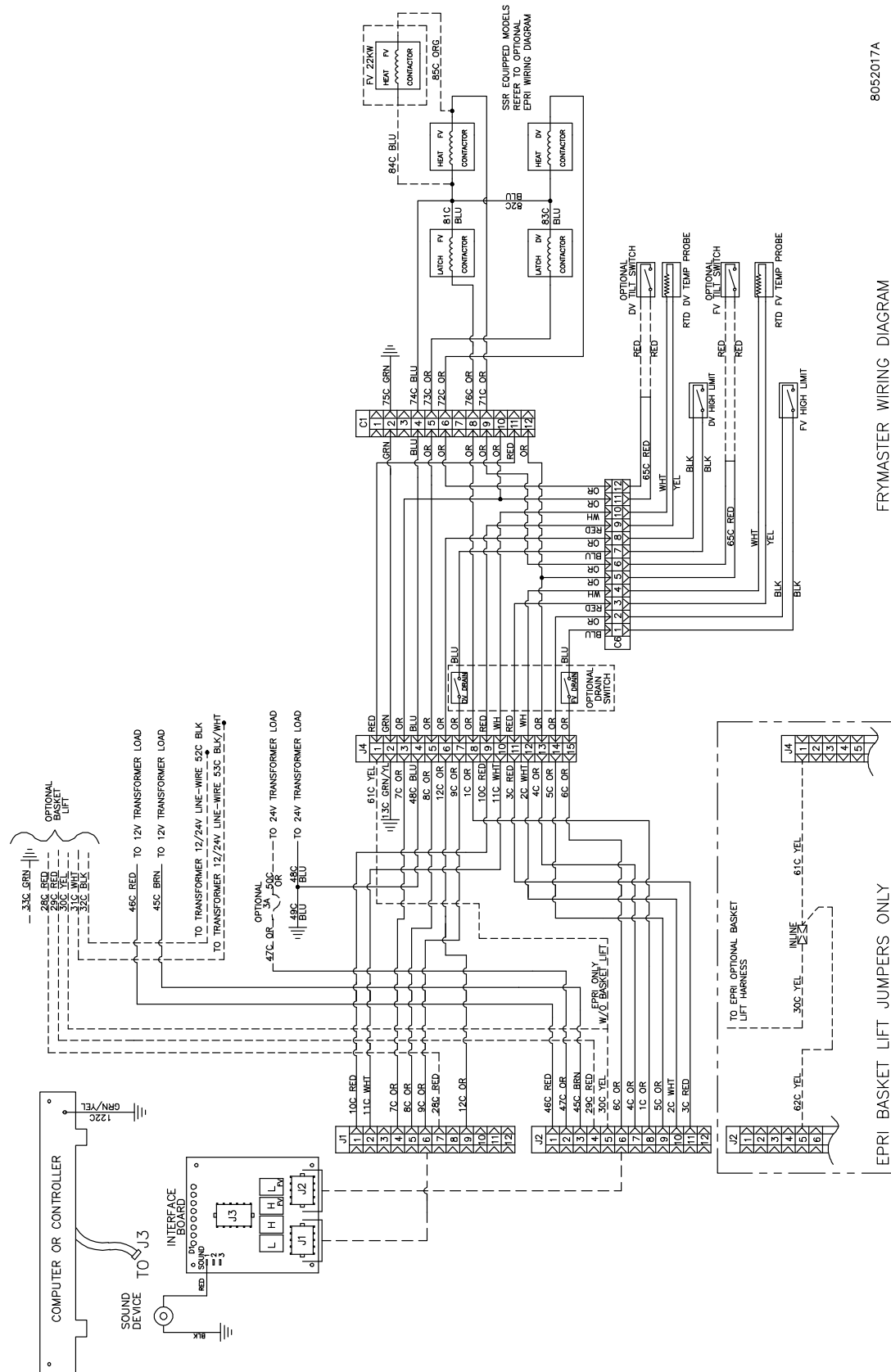

8052017A

FRYMASTER WIRING DIAGRAM

EPRI BASKET LIFT JUMPERS ONLY





# 1.7 Component Wiring With Bulk Oil

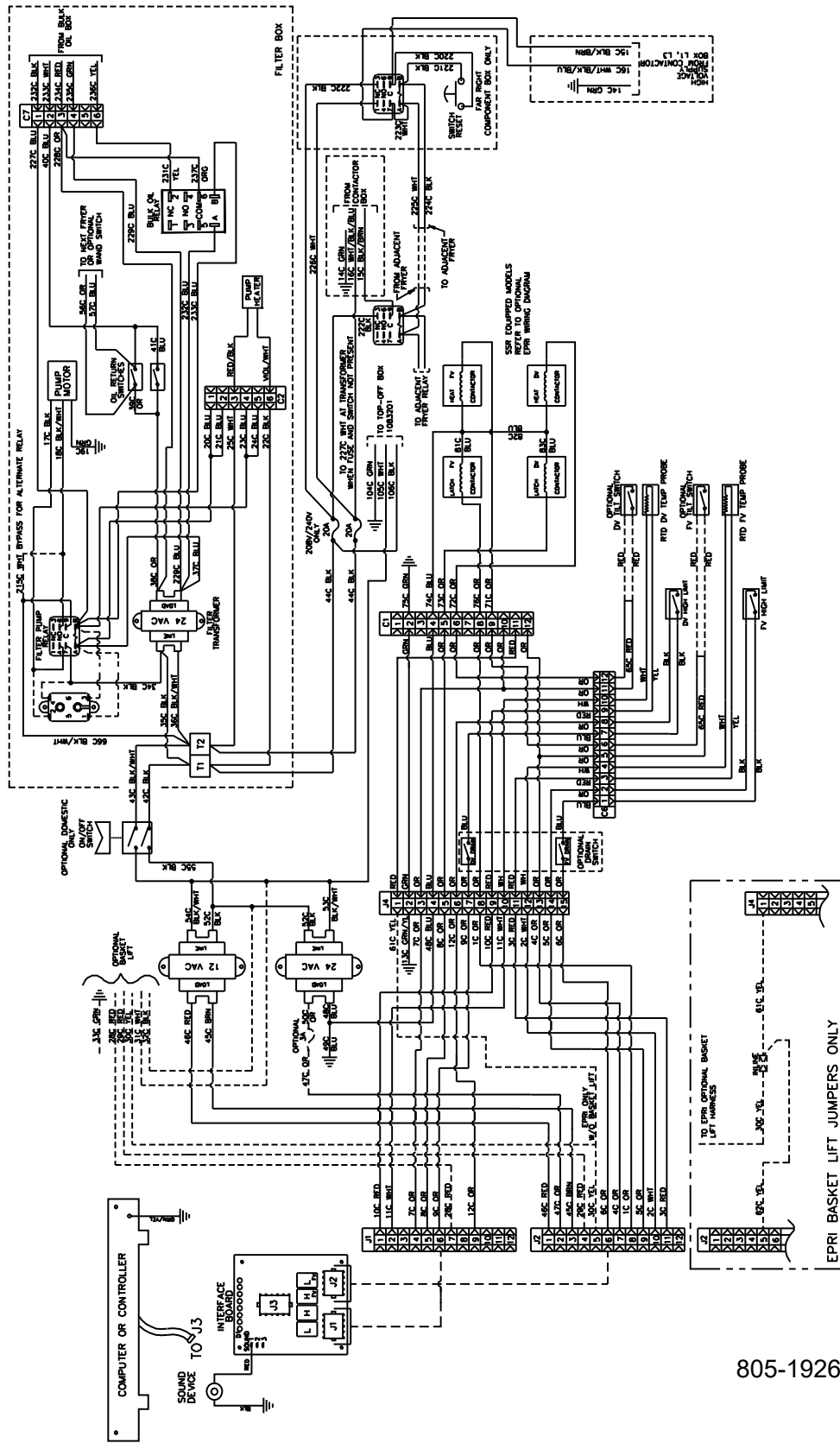

805-1926B

# 1.8 Bulk Oil Wiring Box

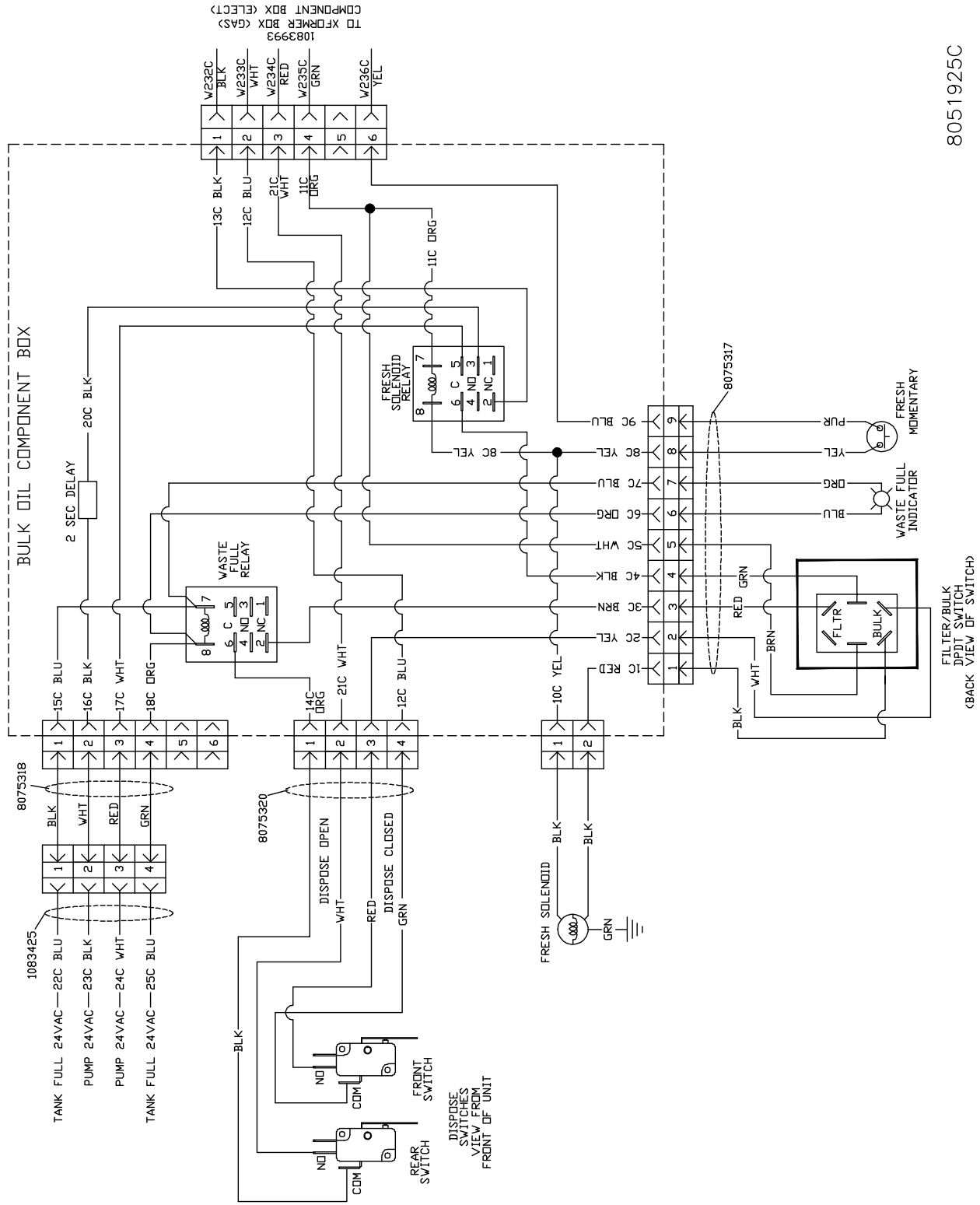

8051925C

# 1.9 Contactor Box – Delta Configuration

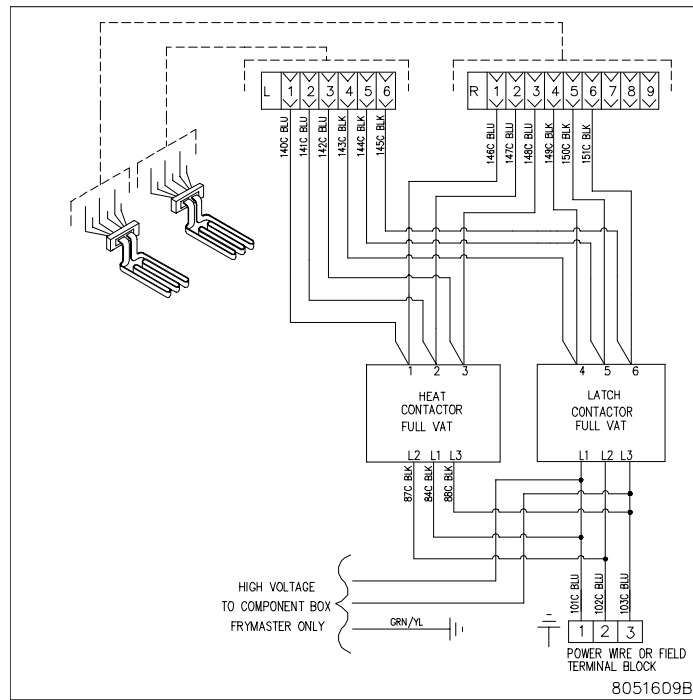

**FULL VAT**

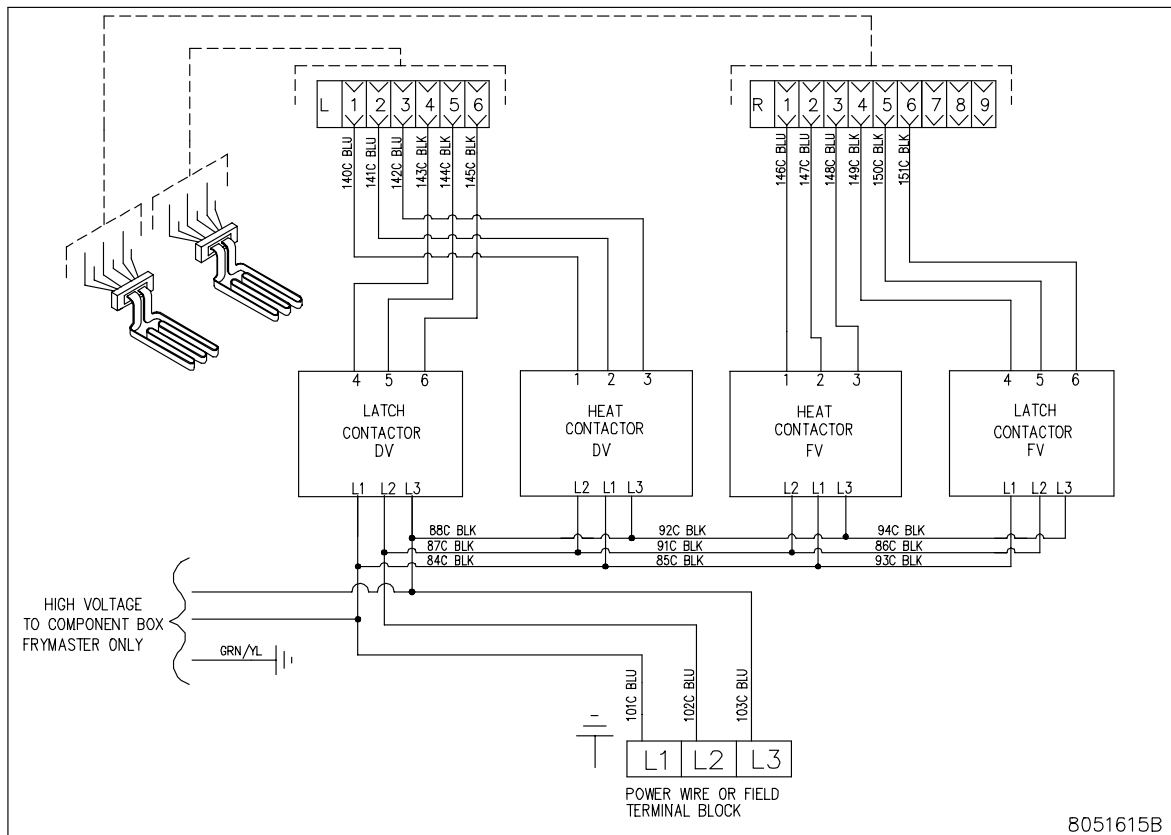

**DUAL VAT**

8051615B

# 1.10 Contactor Box – WYE Configuration

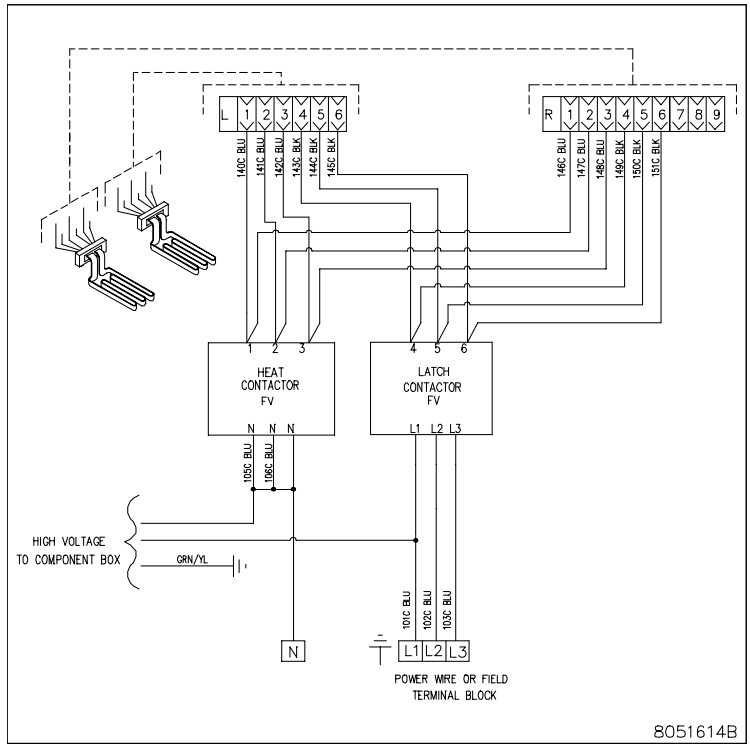

**FULL VAT**

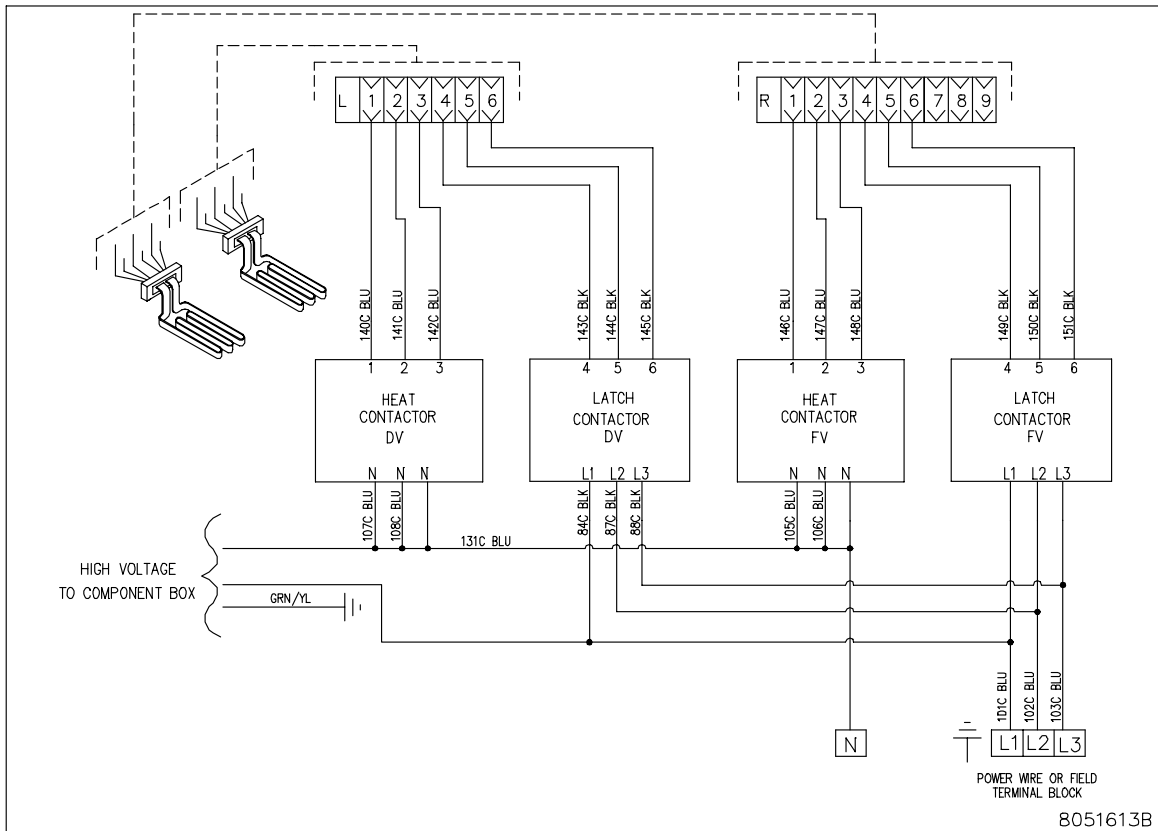

**DUAL VAT**

# 1.11 Solid Shortening

## 1.11.1 Solid Shortening Control Wiring 240V

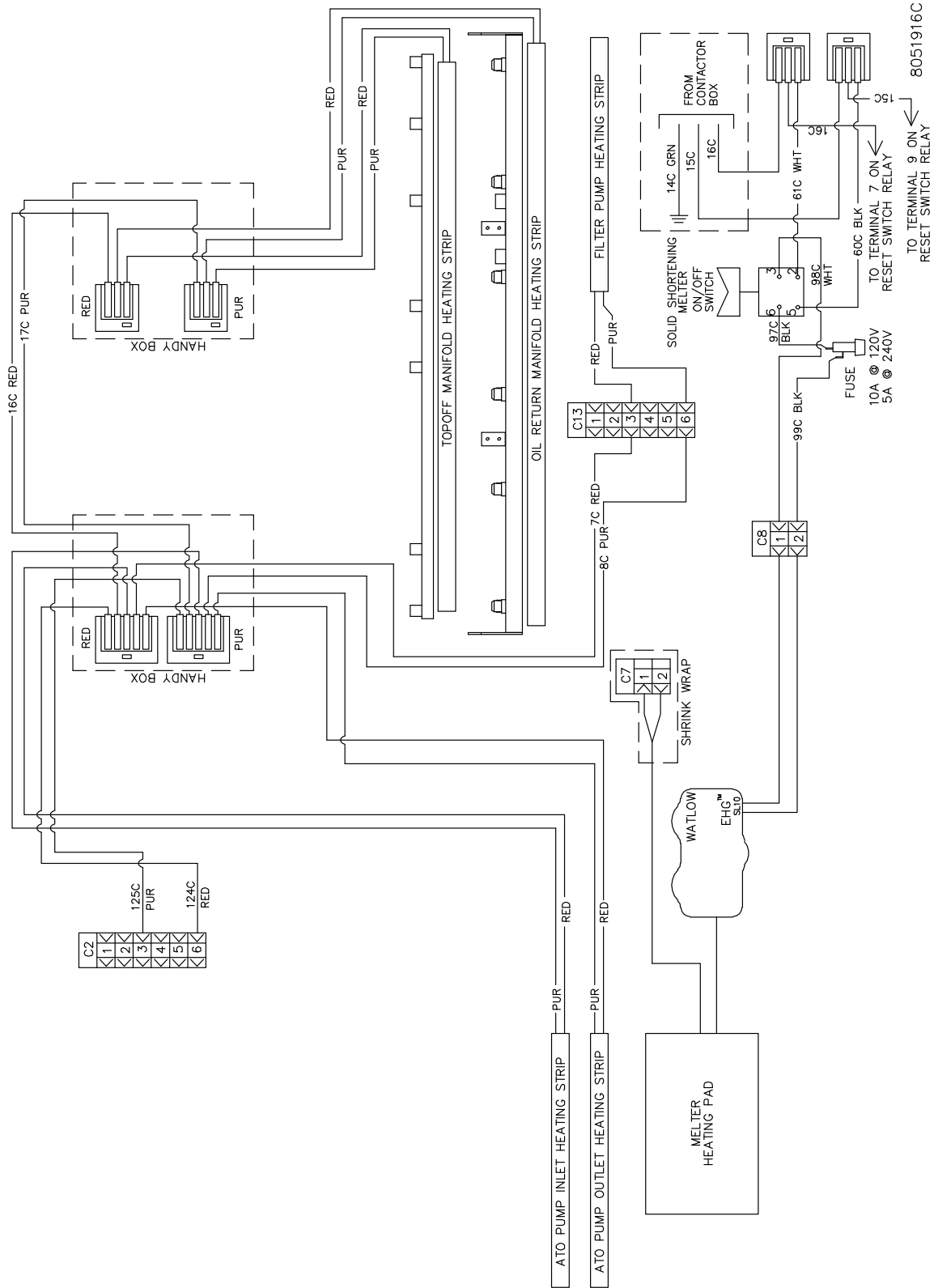

### 1.11.1.2 Solid Shortening Control Wiring 120V

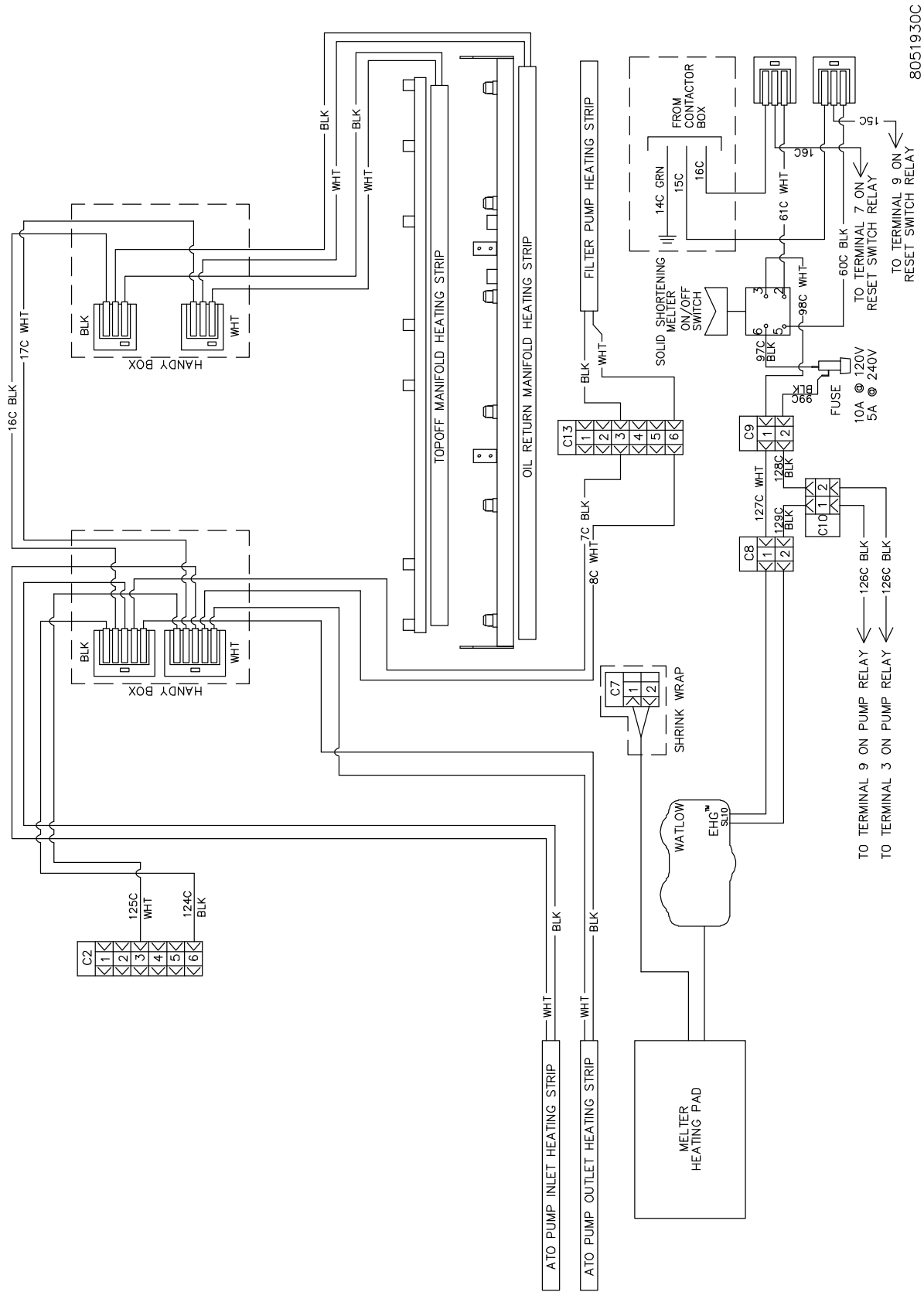

# 1.11.2 Solid Shortening Component Wiring 120V/480V

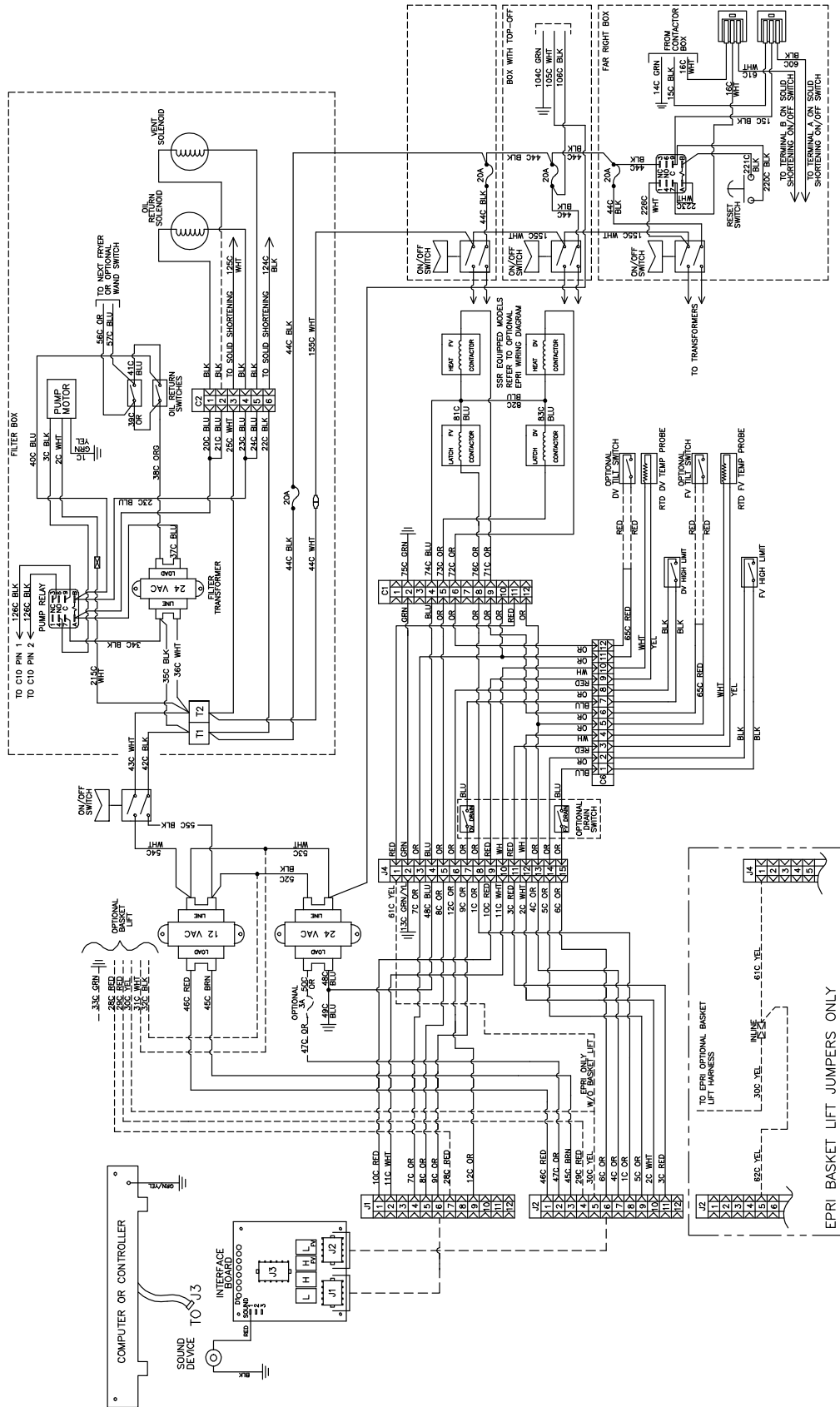

8051929A



## 1.12 Wiring Diagrams

### 1.12.1 Modular Basket Lift Wiring Diagram 208-250V (After Mar. 2002)

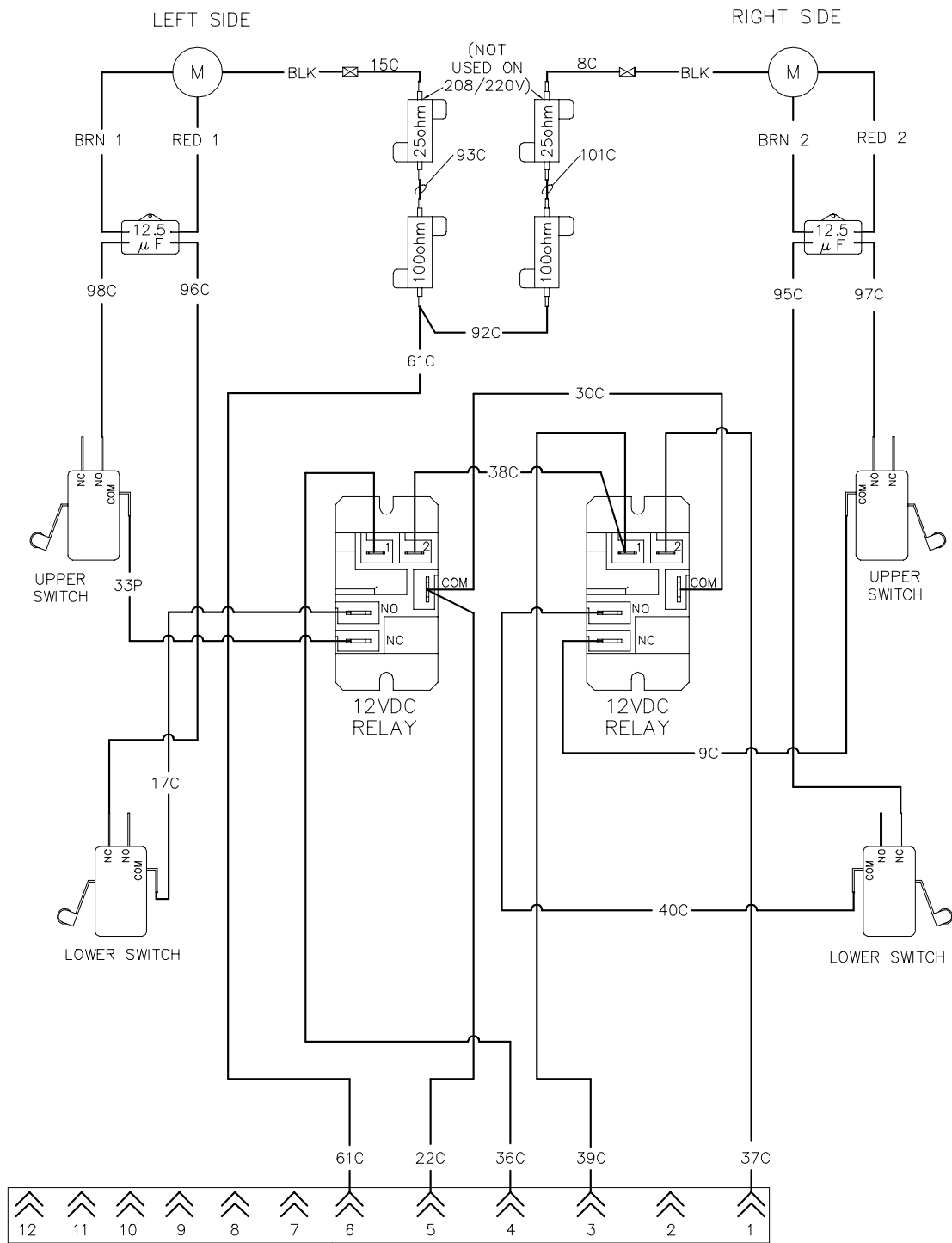

REFERENCES TO LEFT & RIGHT ARE FROM THE REAR OF THE FRYER

8050888D

### 1.12.2 Modular Basket Lift Wiring Diagram 100-120V (After June 2006)

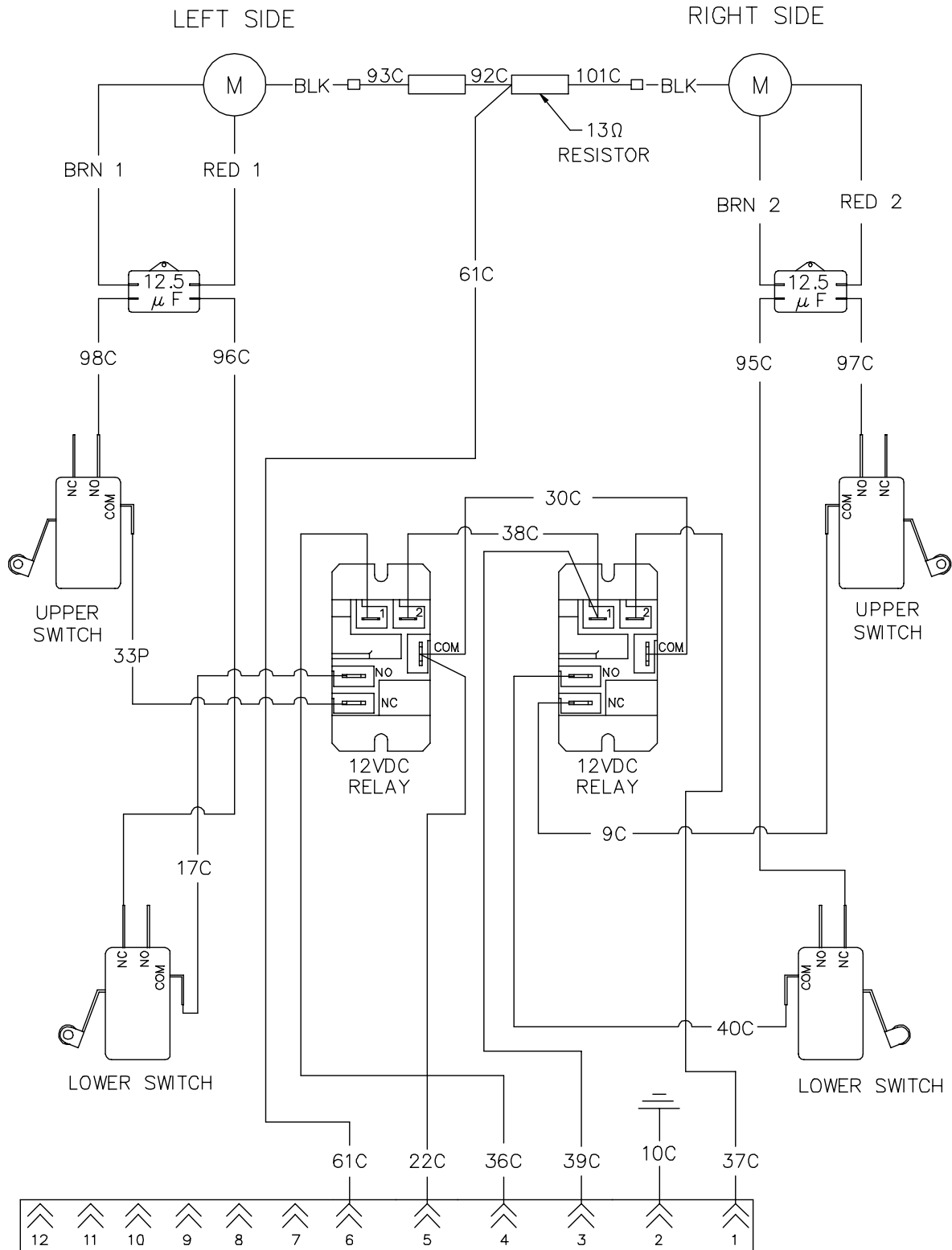

REFERENCES TO LEFT & RIGHT ARE FROM THE REAR OF THE FRYER

8050555E

### 1.12.3 Modular Basket Lift Wiring Diagram 480V (After Jan. 2013)

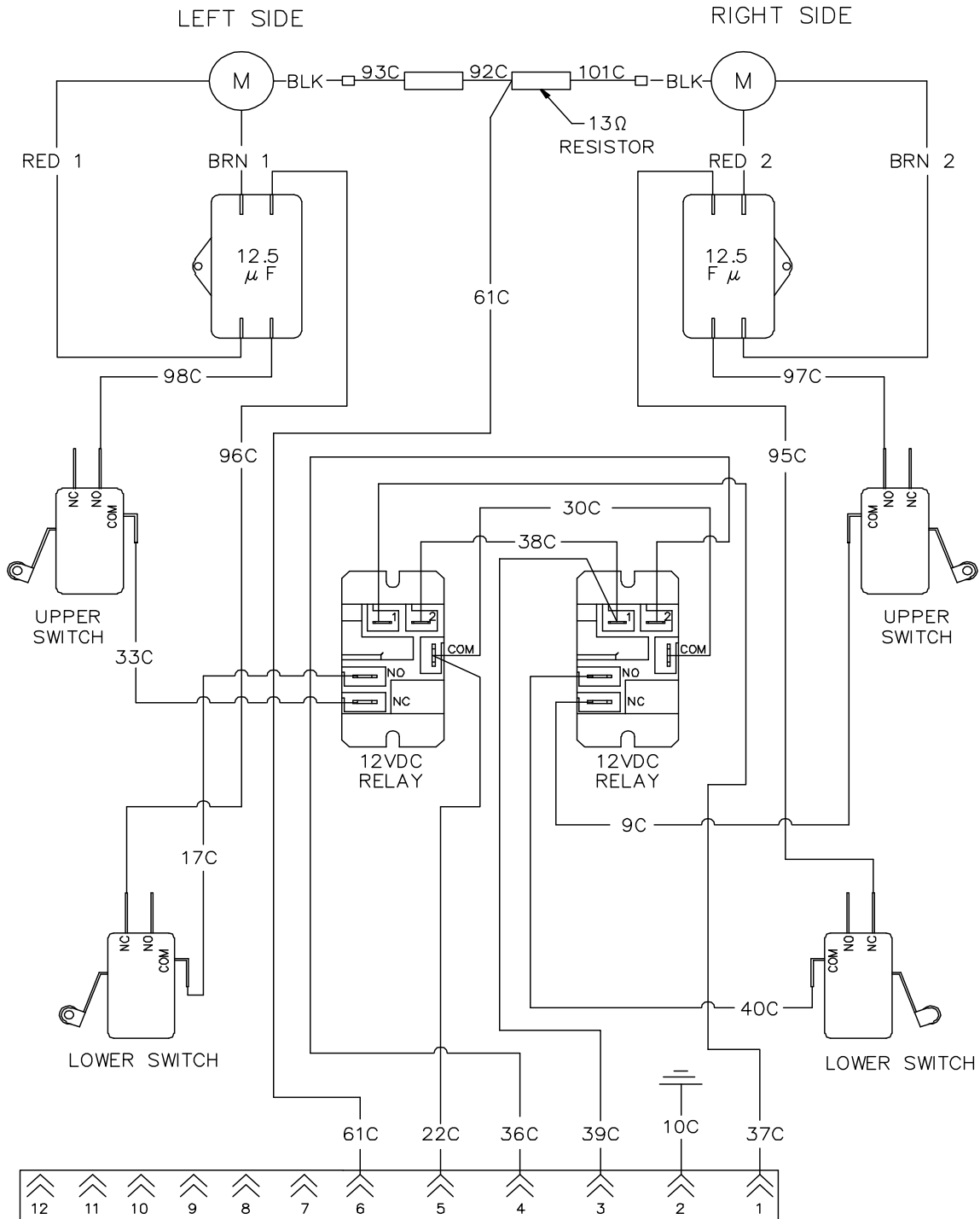

REFERENCES TO LEFT & RIGHT ARE FROM THE REAR OF THE FRYER

8051924C

### 1.12.4 Modular Basket Lift Wiring Diagram 200V-250V (After Feb. 2013)

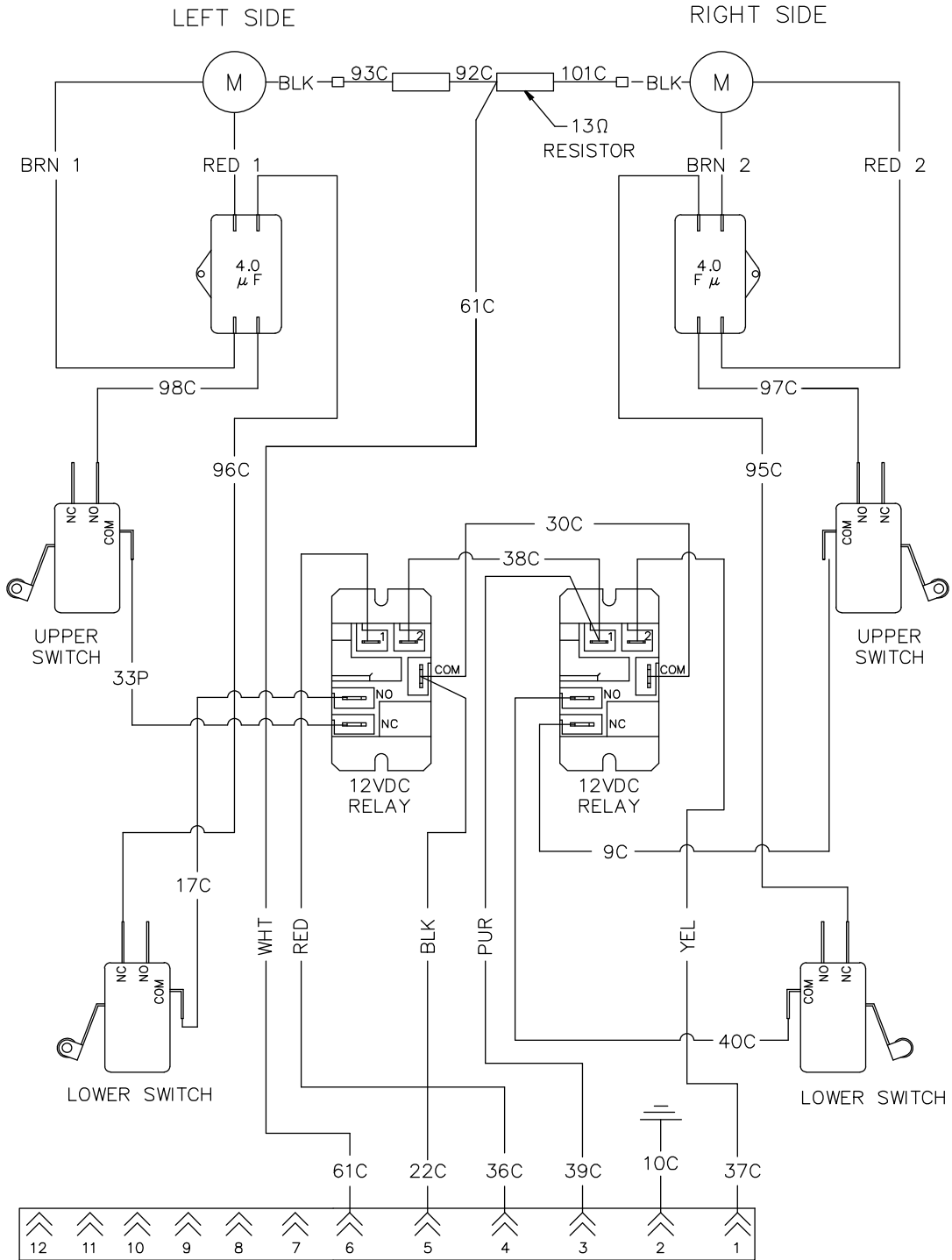

REFERENCES TO LEFT & RIGHT ARE FROM THE REAR OF THE FRYER

8051964B

# 1.13 Terminal Block Wiring

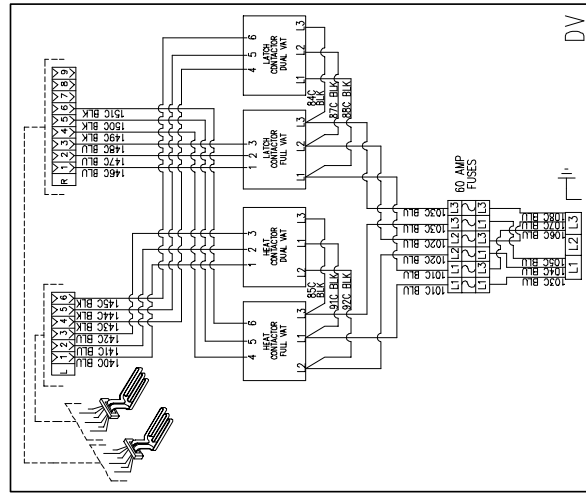
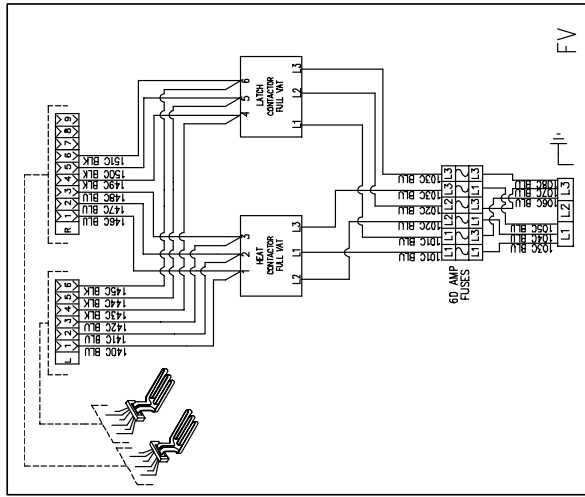

8051652C  
SINGLE PHASE TERMINAL BLOCK WIRING DIAGRAMS

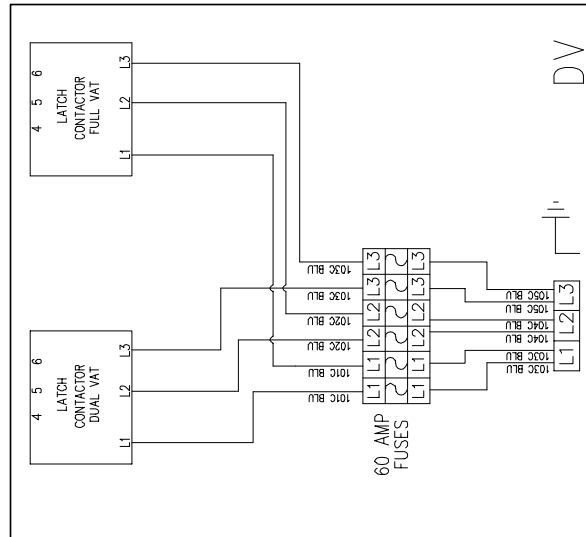
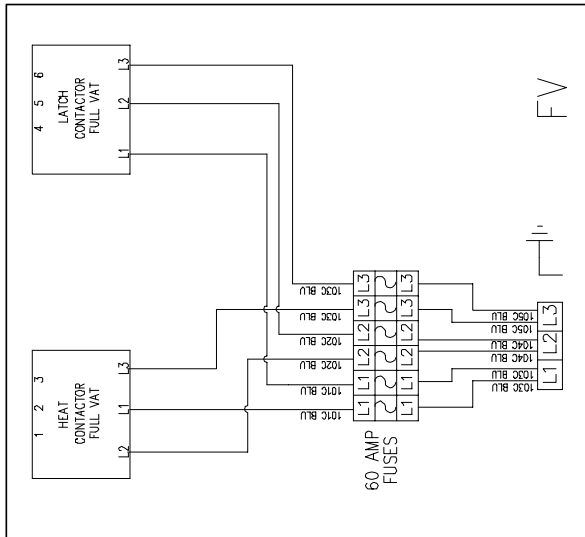

8051634B  
22kW TERMINAL BLOCK WIRING DIAGRAMS

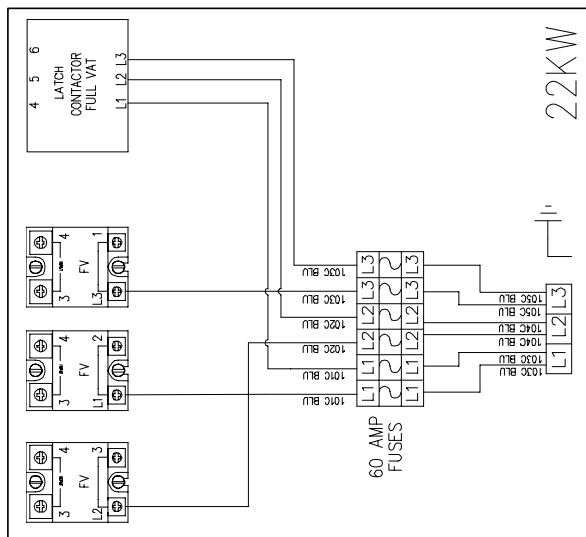
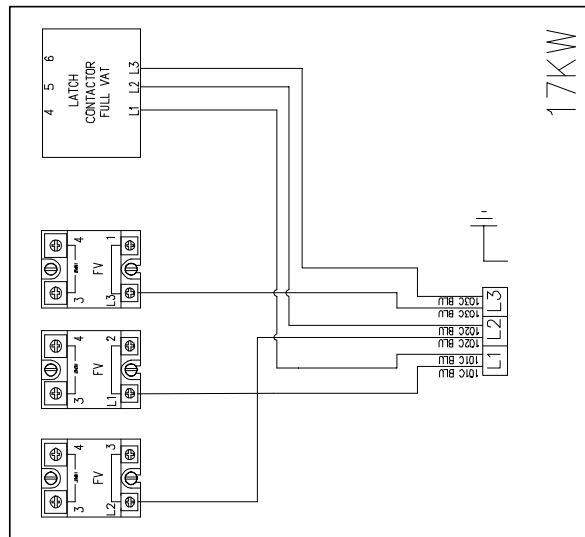

8051633A  
EPR/TRIAC TERMINAL BLOCK WIRING DIAGRAMS

**THIS PAGE INTENTIONALLY LEFT BLANK**

# *Frymaster*<sup>®</sup>

FRYMASTER  
8700 LINE AVENUE, SHREVEPORT, LA 71106-6800

800-551-8633  
318-865-1711  
[WWW.FRYMASTER.COM](http://WWW.FRYMASTER.COM)  
EMAIL: [FRYSERVICE@WELBILT.COM](mailto:FRYSERVICE@WELBILT.COM)



Welbilt offers fully-integrated kitchen systems. Welbilt's portfolio of award-winning brands includes Cleveland™, Convotherm®, Crystal Tips®, Dean®, Delfield®, Fabristeel®, Frymaster®, Garland®, Inducs®, Koldtech®, Kolpak®, Lincoln®, McCann's™, Merco®, Merrychef®, Multiplex®, RDI®, SerVend™, SunFire®, U.S. Range™, and WMaxx™. Supported by service brands: FitKitchen®, kitchen systems; and KitchenConnect®, cloud-based open platform.

*Bringing innovation to the table* • [welbilt.com](http://welbilt.com)

©2023 Frymaster LLC. except where explicitly stated otherwise. All rights reserved. Continuing product improvement may necessitate change of specifications without notice.

Part Number FRY\_D\_8197224 10/2023