

# PF50, PF80, PF80LP, PF110 Portable Filter

## Installation, Operation and Maintenance Manual

This manual is updated as new information and models are released. Visit our website for the latest manual.



 **CAUTION**  
**READ THE INSTRUCTIONS BEFORE USING**



Part Number: FRY\_IOM\_8197541 11/2020

**WARNING**

Safe and satisfactory operation of your equipment depends on its proper installation. Installation **MUST** conform to local codes, or in the absence of local codes, with the latest edition of the National Electric Code, N.F.P.A. 70.

 **WARNING**

**ELECTRICAL GROUNDING INSTRUCTIONS**

This filter is equipped with a three-prong, grounded plug for your protection against shock hazard and should be plugged directly into a properly grounded, three-hole receptacle. Do not cut off, remove or otherwise bypass the grounding prong on this plug.

If it is necessary to use an extension cord, it **MUST** be a three-conductor, grounded cord of 16 gauge or greater.

 **WARNING**

This appliance is not intended for use by children under the age of 16 or persons with reduced physical, sensory or mental capabilities, or lack of experience and knowledge, unless they have been given supervision concerning use of the appliance by a person responsible for their safety. Do not allow children to play with this appliance.

 **WARNING**

Use caution and wear appropriate safety equipment to avoid contact with hot oil or surfaces that may cause severe burns or injury.

 **DANGER**

Do not filter more than one fry tank at a time.

Hot fluid – Do not fill above a point 1-½ inches below the OIL CONTAINER RIM.

 **WARNING**

This filter unit is not suitable for outdoor use. When operating this unit, it **MUST** be placed on a horizontal surface.

 **WARNING**

This filter unit is not suitable for installation in an area where a water jet can be used, and this appliance **MUST NOT** be cleaned with a water jet.

**NOTICE:**

If this filter unit is cleaned with water, disconnect the unit from power source before cleaning and thoroughly dry the filter unit before reconnecting to electrical power source.

 **DANGER**

The crumb tray (if equipped) in portable filter systems must be emptied into a fireproof container at the end of frying operations each day. Some food particles can spontaneously combust if left soaking in certain shortening material.

**NOTICE:**

Drawings and photos used in this manual are intended to illustrate operational, cleaning and technical procedures and may not conform to on-site management operational procedures.

**NOTICE**

**IF, DURING THE WARRANTY PERIOD, THE CUSTOMER USES A PART FOR THIS FRYMASTER EQUIPMENT OTHER THAN AN UNMODIFIED NEW OR RECYCLED PART PURCHASED DIRECTLY FROM FRYMASTER DEAN, OR ANY OF ITS AUTHORIZED SERVICE CENTERS, AND/OR THE PART BEING USED IS MODIFIED FROM ITS ORIGINAL CONFIGURATION, THIS WARRANTY WILL BE VOID. FURTHER, FRYMASTER DEAN AND ITS AFFILIATES WILL NOT BE LIABLE FOR ANY CLAIMS, DAMAGES OR EXPENSES INCURRED BY THE CUSTOMER WHICH ARISE DIRECTLY OR INDIRECTLY, IN WHOLE OR IN PART, DUE TO THE INSTALLATION OF ANY MODIFIED PART AND/OR PART RECEIVED FROM AN UNAUTHORIZED SERVICE CENTER.**



**PF-Series Portable Filtration Systems  
Operation Manual**

**TABLE OF CONTENTS**

	Page
1. INTRODUCTION.....	1-1
2. IMPORTANT INFORMATION.....	2-1
3. FILTER PREPARATION.....	3-1
4. OPERATING/FILTER INSTRUCTIONS.....	4-1
5. CLEANING AND MAINTENANCE.....	5-1
6. TROUBLESHOOTING.....	6-1

# Register Your Warranty Online at

<http://fm-hal.frymaster.com/qsys.lib/cgi.lib/swr290.pgm>



# PF-SERIES PORTABLE FILTRATION SYSTEMS

## CHAPTER 1: INTRODUCTION

---

### 1.1 Parts Ordering

Place parts orders directly with your local Frymaster/Dean Factory Authorized Service agency. A list is accessible on our website at: [www.frymaster.com](http://www.frymaster.com).

To help speed your order, the following information is required:

<b>Model Number</b>		<b>Type</b>	
<b>Serial Number</b>			
<b>Optional Features</b>			
<b>Item Part Number</b>		<b>Quantity Needed</b>	

### 1.2 Service Information

Call the 1-800-551-8633 or (318) 865-1711 Service Hotline number for the location of your nearest Factory Authorized Service agent. Always give the model and serial numbers of your filter unit. Also, identify if your unit is supplied with or without a heater.

To assist you more efficiently, the following information will be needed:

<b>Model Number</b>		<b>Type</b>	
<b>Serial Number</b>			
<b>Optional Features</b>			
<b>Nature of Problem:</b>			

Additional information (i.e. oil temperature at filter time, time of day and other pertinent information) may be helpful in solving your service problem.

**PF-SERIES PORTABLE FILTRATION SYSTEMS**  
**CHAPTER 1: INTRODUCTION**

---

### 1.3 After Purchase

In order to improve service, fill out the following chart with the nearest Frymaster Authorized Service Technician and FAS in your area.

Authorized Service Technician/FAS	
Address	
Telephone/Fax	
Filter Model Number	
Filter Serial Number	

### 1.4 Safety Information

Before attempting to operate your unit, read the instructions in this manual thoroughly.

Throughout this manual, you will find notations enclosed in double-bordered boxes similar to the ones below.

 **CAUTION**

**CAUTION** boxes contain information about actions or conditions that *may cause or result in a malfunction of your system.*

 **WARNING**

**WARNING** boxes contain information about actions or conditions that *may cause or result in damage to your system,* and which may cause your system to malfunction.

 **DANGER**

**DANGER** boxes contain information about actions or conditions that *may cause or result in injury to personnel,* and which may cause damage to your system and/or cause your system to malfunction.

**PF-SERIES PORTABLE FILTRATION SYSTEMS  
CHAPTER 1: INTRODUCTION**

---

## **1.5 Service Personnel**

### **1.5.1 Definitions**

#### **A. Qualified and/or Authorized Operating Personnel**

1. Qualified/authorized operating personnel are those who have carefully read the information in this manual and have familiarized themselves with the equipment functions, or have had previous experience with the operation of equipment covered in this manual.

#### **B. Qualified Installation Personnel**

1. Qualified installation personnel are individuals, or firms, corporations, or companies that, either in person or through a representative, are engaged in and are responsible for the installation of electrical appliances. Qualified personnel must be experienced in such work, be familiar with all electrical precautions involved, and have complied with all requirements of applicable national and local codes.

#### **C. Qualified Service Personnel**

Qualified service personnel are those who are familiar with Frymaster/Dean equipment and have been authorized by Frymaster/Dean to perform service on Frymaster/Dean equipment. All authorized service personnel are required to be equipped with a complete set of service parts manuals and stock a minimum amount of parts for Frymaster/Dean equipment. A list of FAS agencies is accessible on our website at: [www.frymaster.com](http://www.frymaster.com).

***Failure to use qualified service personnel will void the Frymaster/Dean warranty on your equipment.***

# PF-SERIES PORTABLE FILTRATION SYSTEMS

## CHAPTER 2: IMPORTANT INFORMATION



### 2.1 General

The PF-series portable filters can be used with a variety of Frymaster fryers, as well as other manufacturers' equipment. Unit specifications are listed below.

Model	Unit Height (inches)	Unit Width (inches)	Unit Length (inches)	Tank Height Front (inches)	Oil Capacity (pounds)
PF50	13.25	13.25	30	11.75	50
PF80	24.75	17.25	30.25	11.25	80
PF80LP	24.75	17.25	38 5/8	10.5	80
PF110	24.75	17.25	30.25	13.25	110

Oil is gravity-drained from the fryer into the filter or pumped from the frypot into the filter pan, and then filtered through filter paper. Filter powder, which enhances the filtering process, is distributed over the paper prior to filtering.

All units are shipped completely assembled with accessories packed inside the filter pan. All units are adjusted, tested and inspected at the factory before shipment.

#### **⚠ WARNING**

**The on-site supervisor is responsible for ensuring that operators are made aware of the inherent dangers of operating a hot oil filter system, particularly the aspects of oil filtration, and draining/cleaning procedures.**

# PF-SERIES PORTABLE FILTRATION SYSTEMS

## CHAPTER 2: IMPORTANT INFORMATION

A Suction/Off/Return switch activates/deactivates the filter pump. The filter also has a Heater/Filter switch for use when filtering solid shortening.

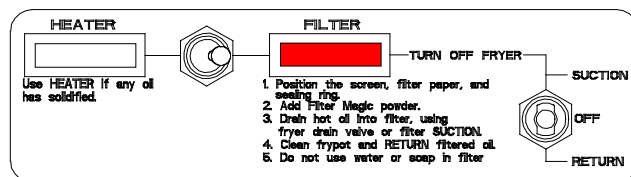

PF switch/light panel.

A thermal-overload switch on the pump motor provides protection against overheating.

**NOTE:** *If the thermal overload is triggered, wait 45 minutes, and then press the reset button to activate the circuit after the failure has been detected and repaired.*

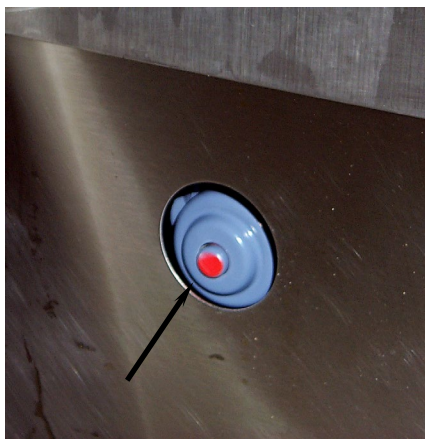

The motor thermal overload switch (arrow) is located on the left side of the filter.

## 2.2 Rating Plate

Information on the rating plate includes model and serial numbers, as well as electrical requirements. The rating plate is located on the back housing, near the electrical receptacle. Have the rating plate information handy when communicating with the factory about a unit or requesting special parts or information. Without rating plate information, proper identification of the unit cannot be confirmed.

**PF-SERIES PORTABLE FILTRATION SYSTEMS**  
**CHAPTER 2: IMPORTANT INFORMATION**

---

## 2.3 Pre-Installation

**NOTE: Failure to use qualified service personnel will void the Frymaster warranty.**

- A. Standards: Use of this filter unit must be in accordance with all applicable state and local codes.

 **DANGER**

**This portable filter is equipped with a three-prong (grounding) plug for protection against electrical shock and must be plugged directly into a properly grounded, three-prong receptacle. DO NOT CUT, REMOVE, OR OTHERWISE BYPASS THE GROUNDING PRONG ON THIS PLUG!**

- B. Electrical Connections: Domestic PF-filter units require 115V 60 Hz., 15 amp electrical supply. International/CE units require 230V 50 Hz., 7 amp electrical supply. Units are equipped with a grounded male receptacle for use with a 16-3 SJT power cord set. If an extension cord is required, it must be a three-conductor, grounded power cord of at least 16 gauge.

## 2.4 Unpacking the Filter System

Ensure the container is upright. Unpack the filter carefully and remove all accessories from the carton. Do not discard or misplace parts and/or accessories; they will be needed for filter setup and operation. Any accessories or starter kits included with the unit will be packaged inside the filter tank.

After unpacking, immediately check the equipment for visible signs of shipping damage. If such damage has occurred, contact the carrier and file the appropriate freight claims. Do not contact the factory, as the responsibility of shipping damage is between the carrier and dealer or end-user.

If your equipment arrives damaged:

- a. File claim for damages immediately – Regardless of extent of damage.
- b. Visible loss or damage – Be sure this is noted on the freight bill or express receipt and is signed by the person making the delivery.
- c. Concealed loss or damage – If damage is unnoticed until equipment is unpacked, notify freight company or carrier immediately, and file a concealed damage claim. This should be done within 15 days of date of delivery. Retain the shipping container for inspection.

**NOTE: Frymaster does not assume responsibility for damage or loss incurred in transit.**

# PF-SERIES PORTABLE FILTRATION SYSTEMS

## CHAPTER 3: FILTER PREPARATION

### 3.1 Assembling The Filter System

On initial installation and before each use, remove all loose parts from the filter, wash all accessories in hot, soapy water and dry thoroughly. **DO NOT WASH INTERIOR OF FILTER PAN WITH DETERGENT OR WATER!** Wipe debris and residue from the filter pan with a damp cloth or paper towel, then with a dry cloth or paper towel.

**⚠ WARNING!**

**Water, detergent or boil-out solution MUST NOT be allowed into the filter pan or filter system. Irreversible pump damage will result if water is allowed into the system, and the warranty will be voided.**

PF-Series portable filtration systems use a filter support grid, one sheet of filter paper and a hold-down ring to secure the filter paper in place.

See illustration for proper assembly.

1. Filter Pan Cover  
Crumb Basket where applicable
2. Hold-Down Ring
3. Filter Paper (one sheet)
4. Screen/Support Grid
5. Filter Pan

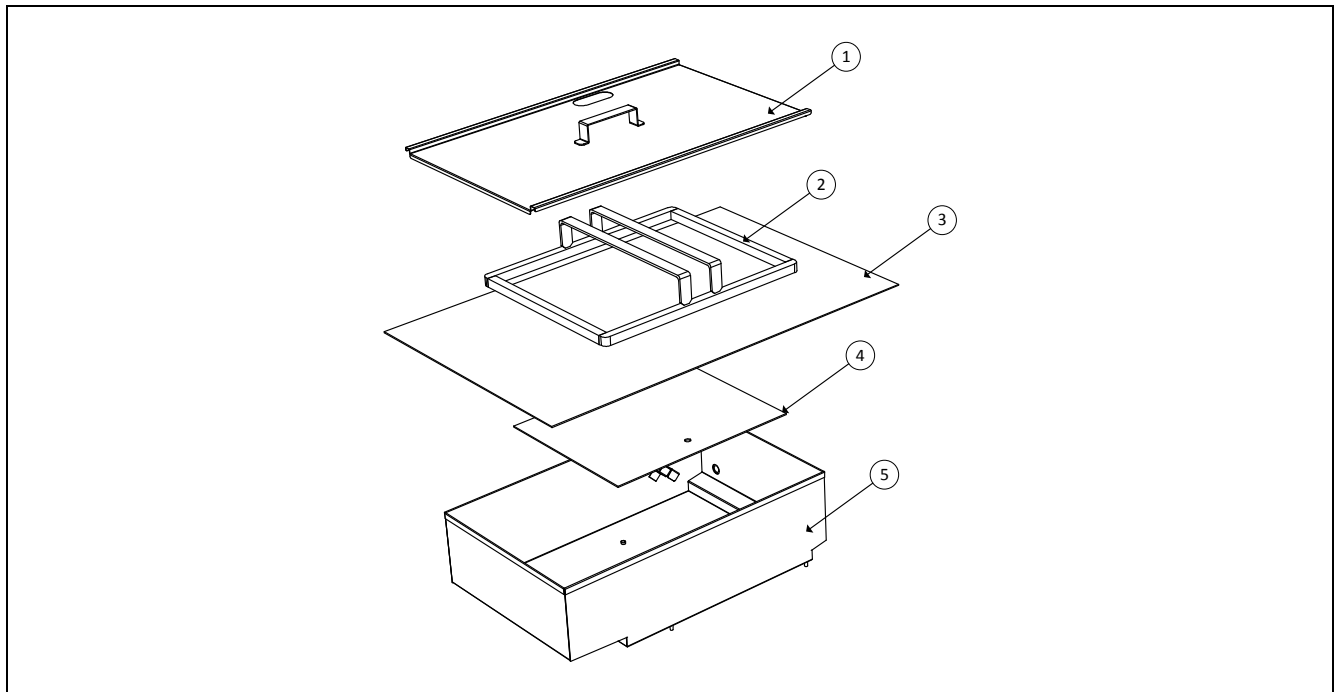

**PF-SERIES PORTABLE FILTRATION SYSTEMS**  
**CHAPTER 3: FILTER PREPARATION**

---

### **3.1 Assembling The Filter System (cont.)**

1. Ensure the filter pan is clean and free of all food and breading particles that could prevent the filter paper from sealing against the bottom of the pan.
2. Place the filter paper support screen between the raised dimples in the bottom of the pan.
3. Place one sheet of filter paper on top of the support screen. Ensure the paper evenly covers the filter pan bottom.
4. Position the hold-down ring on top of the filter paper and ensure the filter paper overlaps all sides of the hold-down ring, forming a tight seal.
5. Place filter pan cover onto the filter pan and assembly is complete.

**NOTE:** The filter paper for this unit is oversized, which ensures a good seal. Lap excess paper up the walls of the pan. **Do Not** fold the paper to fit the pan.

# PF-SERIES PORTABLE FILTRATION SYSTEMS

## CHAPTER 4: OPERATING/FILTERING INSTRUCTIONS

### 4.1 Filter Operation (Suction and Return)

#### WARNING

Use care when draining and filtering oil to avoid the possibility of a serious burn.

1. Sprinkle 8 ounces (1 cup) of filter powder over the filter paper, distributing the powder as evenly as possible. If filtering a second frypot immediately after the first, add only 4 ounces of filter powder for the second filtering.
2. Ensure the power cord is securely plugged into the receptacle on the back of the portable filter. Plug the power cord into an 115V receptacle.
3. If solid shortening is filtered through the portable filter, turn the Heater/Filter switch to HEATER (see illustration below). The white indicator light will illuminate. Leave the heater on for 20-30 minutes before operating the filter.

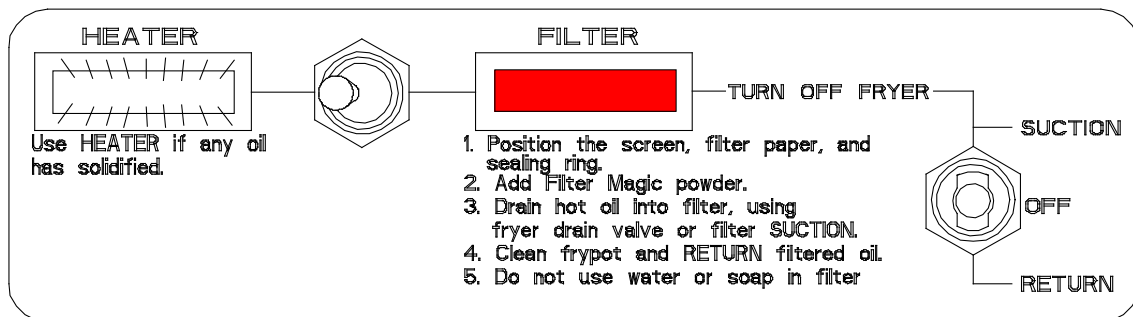

Use the filter heater for 20-30 minutes prior to filtering if solid shortening is filtered.

**Note: The filter pump cannot be activated while the switch is in the "Heater" position.**

4. Ensure the Suction/Off/Return switch is OFF. Turn the Heater/Filter switch to FILTER for filter operation (see illustration below). The red indicator light will illuminate.

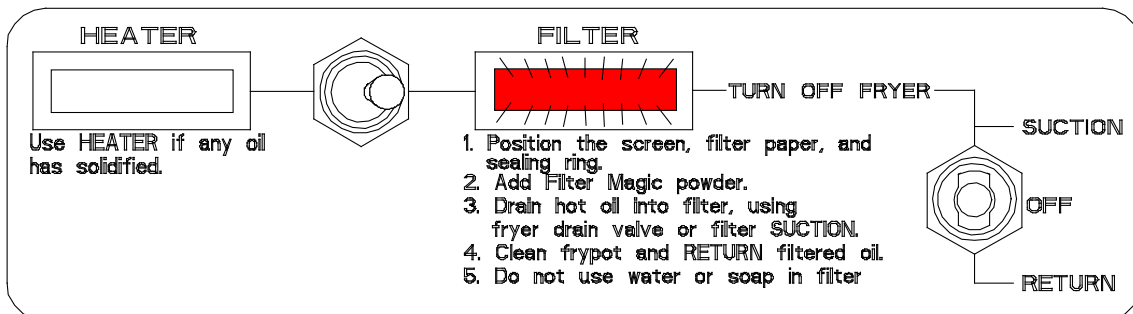

The Heater/Filter switch must be in the FILTER position before the filter pump can be operated. The red light will illuminate when the switch is properly positioned.

**PF-SERIES PORTABLE FILTRATION SYSTEMS  
CHAPTER 4: OPERATING/FILTERING INSTRUCTIONS**

---

### 4.1 Filter Operation (cont.)

5. Ensure the oil is at operating temperature [ $\sim 350^{\circ}$  ( $177^{\circ}\text{C}$ )]. Turn the fryer off.

**! WARNING**

**The filter pan maximum capacity varies with model. DO NOT OVERFILL THE FILTER PAN.**

#### 6. Return/Suction:

- a. Suction Operation: Ensure the filter pan lid is in place to prevent splashing of hot oil. Place the filter hose nozzle into the frypot. Turn the Suction/Off/Return switch to SUCTION to start the filter pump (see illustration below). Oil will transfer from the frypot to the filter pan.

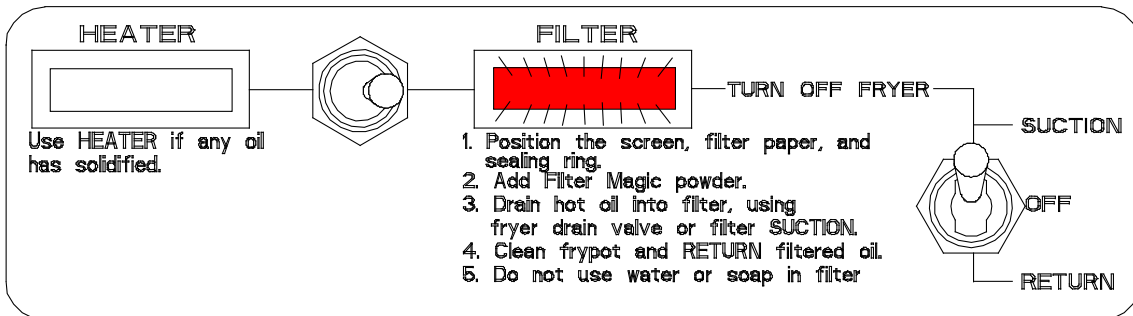

**! CAUTION**

**DO NOT insert the tip of the nozzle into the sediment area of the frypot. Suction of sediment into the nozzle will damage the filter pump. If the pump becomes clogged, stop the pump immediately. Reverse the pump to discharge particles into the frypot or filter pan.**

When the fryer is emptied of oil, place the nozzle into the filter pan and turn the Suction/Off/Return switch to RETURN (see illustration below). Circulate the oil through the filter for approximately 5 minutes (process known as "polishing"). Polishing the oil maximizes filtering and extends the life of the oil. After 5 minutes, turn the Suction/Off/Return switch to OFF.

# PF-SERIES PORTABLE FILTRATION SYSTEMS

## CHAPTER 4: OPERATING/FILTERING INSTRUCTIONS

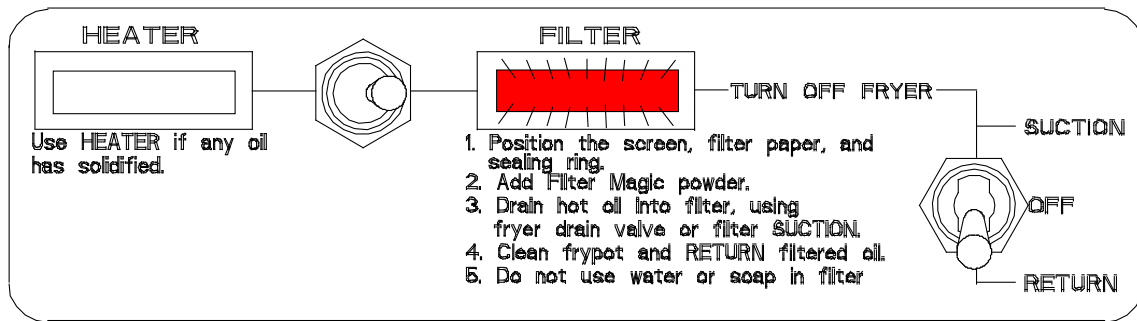

### 4.1 Filter Operation (cont.)

To flush residual shortening and sediment from the frypot, place a clean metal container under the frypot drain valve. Open drain valve and place the hose nozzle inside the frypot. Turn the Suction/Off/Return switch to RETURN. Rinse and flush sediment and debris from frypot, into the metal container. **DO NOT OVERFILL THE CONTAINER.** Turn the Suction/Off/Return switch to OFF after rinsing the frypot.

Wipe any remaining oil or sediment from the frypot with a clean, dry cloth or paper towel. Close the drain valve. Pour the contents of the metal container into the filter pan, using care not to splash hot oil. Place the hose nozzle into the frypot and turn the Suction/Off/Return switch to RETURN. Ensure all oil is returned to the frypot before turning filter off.

Allow the portable filter to cool, then remove and discard the filter paper. Clean the interior of the filter pan and all components. Do not use detergent or water in the filter pan for cleaning.

### 7. PF50S Gravity Drain:

- Place filter pan directly under fryer drain valve and drain oil into the filter. Place the filter hose nozzle securely inside the frypot. Turn the Suction/Off/Return switch to RETURN to start the filter pump (see illustration below).

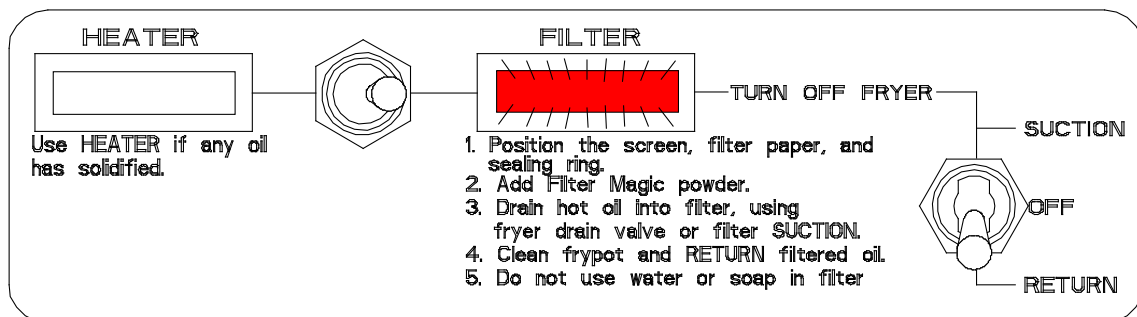

Allow the oil to circulate through the frypot and filter for approximately 5 minutes (process known as "polishing"). Polishing the oil produces maximum filtration and extends the life of the oil. Rinse any residual oil or sediment from the frypot during the polishing process.

## PF-SERIES PORTABLE FILTRATION SYSTEMS

### CHAPTER 4: OPERATING/FILTERING INSTRUCTIONS

---

Close the drain valve and allow the frypot to fill. Ensure all oil is returned to the frypot before turning filter off.

Allow the portable filter to cool, then remove and discard the filter paper. Clean the interior of the filter pan and all components. Do not use detergent or water in the filter pan for cleaning.

**See Chapter 5 for preventative maintenance/cleaning procedures.**

**PF-SERIES PORTABLE FILTRATION SYSTEMS**  
**CHAPTER 4: OPERATING/FILTERING INSTRUCTIONS**

---

## 4.2 Filter Operation (Return Only)

**⚠ WARNING**

**Use care when draining and filtering oil to avoid the possibility of a serious burn.**

1. Sprinkle 8 ounces (1 cup) of filter powder over the filter paper, distributing the powder as evenly as possible. If filtering a second frypot immediately after the first, add only 4 ounces of filter powder for the second filtering.
2. Ensure the power cord is securely plugged into the receptacle on the back of the portable filter. Plug the power cord into an 115V outlet.
3. If solid shortening is filtered through the portable filter, turn the Heater/Filter switch to HEATER (see illustration below). The white indicator light will illuminate. Leave the heater on for 20-30 minutes before operating the filter.

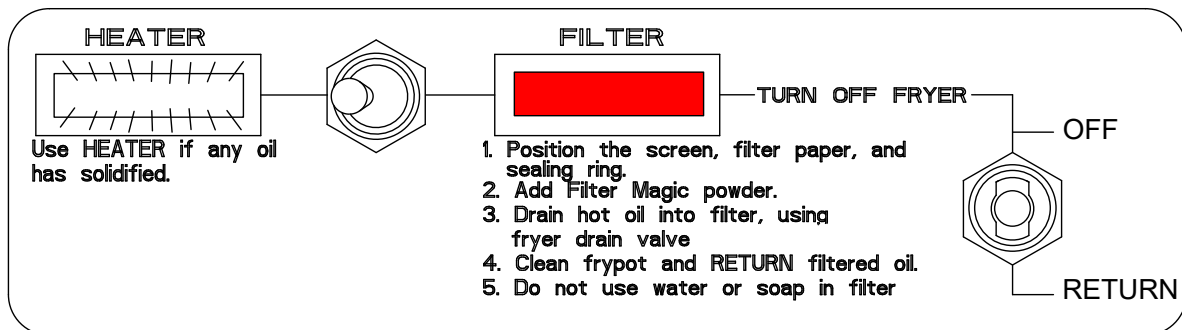

Use the filter heater for 20-30 minutes prior to filtering if solid shortening is filtered.

**Note: The filter pump cannot be activated while the switch is in the "Heater" position.**

4. Ensure the Off/Return switch is OFF. Turn the Heater/Filter switch to FILTER for filter operation (see illustration below). The red indicator light will illuminate.

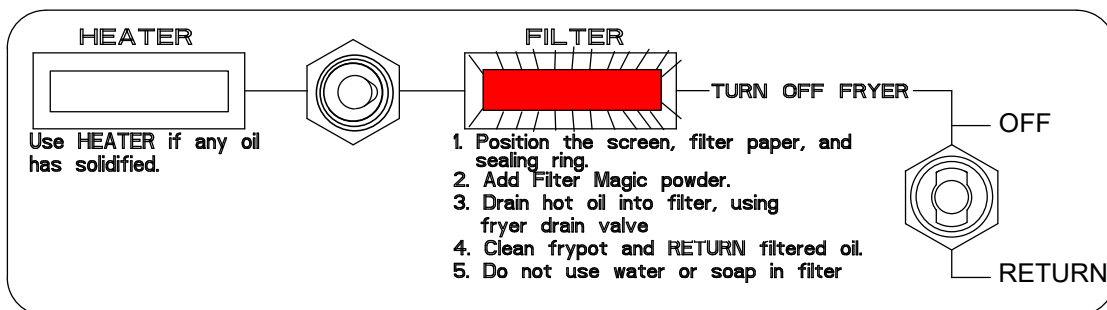

The Heater/Filter switch must be in the FILTER position before the filter pump can be operated. The red light will illuminate when the switch is properly positioned.

**PF-SERIES PORTABLE FILTRATION SYSTEMS  
CHAPTER 4: OPERATING/FILTERING INSTRUCTIONS**

---

## 4.2 Filter Operation (cont.)

5. Ensure the oil is at operating temperature, 350°F (177°C). Turn the fryer off.

**⚠ WARNING**

**The filter pan maximum capacity is 50 lbs. DO NOT OVERFILL THE FILTER PAN.**

6. Place filter pan directly under fryer drain valve and drain oil into the filter. Place the filter hose nozzle inside the frypot. Turn the Off/Return to RETURN to start the filter pump (see illustration below).

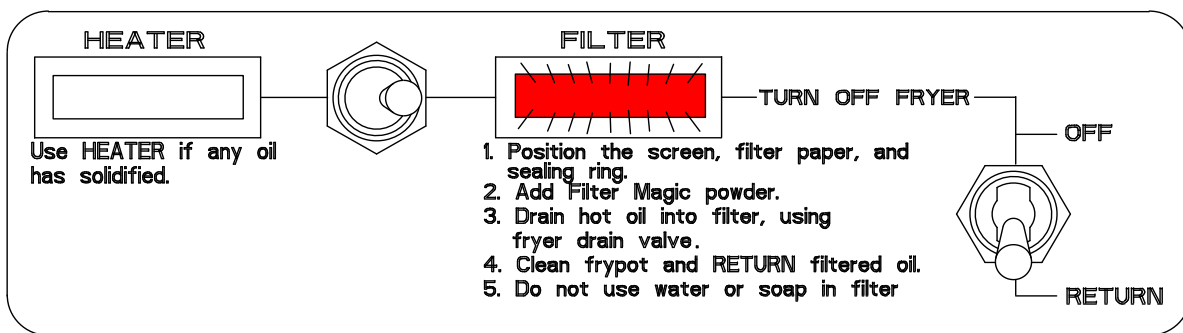

Allow the oil to circulate through the frypot and filter for approximately 5 minutes (process known as "polishing"). Polishing the oil produces maximum filtration and extends the life of the oil. Rinse any residual oil or sediment from the frypot during the polishing process.

Close the drain valve and return the filtered oil to the frypot. Ensure all oil is returned to the frypot before turning filter off.

Allow the portable filter to cool, then remove and discard the filter paper. Clean the interior of the filter pan and all components. Do not use detergent or water in the filter pan for cleaning.

**See Chapter 5 for preventive maintenance/cleaning procedures.**

# PF-SERIES PORTABLE FILTRATION SYSTEMS

## CHAPTER 5: CLEANING AND MAINTENANCE

---

### 5.1 General

Cleaning operations fall into three general categories:

- Wiping unit clean after each filter session;
- Cleaning, changing filter paper and preparing the unit for the next day's business.
- Weekly cleaning to remove oil deposits and other particles.

 **WARNING**

**Do not use water jets to clean this equipment. To do so will damage the unit and void the warranty.**

 **WARNING**

**Never operate the filter unit unless cooking oil is at operating temperature.**

### 5.2 Each Filter Use

Each time the PF-series portable filter is used:

- Wash down the insides of the filter pan with hot oil during the filtering process. DO NOT allow excessive residue buildup to occur inside the filter pan.
- Change filter paper after each filter session or at the end of the day. Scrape excess sediment from filter paper after each frypot is filtered. If oil is not returned to the frypot within 7 minutes, the filter paper may be clogged. Change filter paper if this occurs.
- Wipe up any oil which may have splashed or spilled.
- Wipe all exterior surfaces of the filter unit.

 **WARNING**

**Do not run water or boil-out solution through the portable filter. Doing so will cause irreparable damage to the pump, and void the warranty.**

## PF-SERIES PORTABLE FILTRATION SYSTEMS

### CHAPTER 5: CLEANING AND MAINTENANCE

---

#### 5.3 Daily— Close Of Business

At the close of a working day, filter the oil in all fryers. When the last fryer is filtered, follow these steps:

1. Ensure the flexible hose and pump lines are clear by running the filter pump for an additional 15–30 seconds after air bubbles start coming from the oil return line. Drain the flexible hose as much as possible, especially if solid shortening is used.
2. Remove the filter pan cover and hold-down ring, and then remove the filter paper and filter paper support screen.
3. Discard filter paper.
4. Wash all filter components with hot soapy water and rinse. DO NOT use soap and/or water inside the filter pan. Wipe residual oil and sediment from inside the filter pan with a clean cloth or paper towel.
5. Rinse all parts with clean water (except filter pan interior), and then dry all filter parts thoroughly before reassembling.
6. Check the hose fitting on the pump and ensure that it is tight. Check plumbing for leaks. See Chapter 6 for troubleshooting procedures. Check plumbing for leaks.

 **DANGER**

**The crumb tray (if applicable) in portable filter systems must be emptied into a fireproof container at the end of frying operations each day. Some food particles can spontaneously combust if left soaking in certain shortening material.**

#### 5.4 Weekly

Follow the same procedure as for "Daily", with these additional steps:

- Clean built-up residue and debris from filter pan by wiping with a clean cloth or paper towel. DO NOT use soap and/or water inside the filter pan. Ensure all components fit properly and function correctly.
- Clean thoroughly under, around, and behind the fryers and filtering area with hot soapy water and rinse.
- Check the hose connection and tighten if hose becomes loose and starts to leak oil.

# PF-SERIES PORTABLE FILTRATION SYSTEMS

## CHAPTER 6: TROUBLESHOOTING

---

### 6.1 Operating Problems

Plugged lines and plugged filter paper account for over 90 percent of filtration system malfunctions. A general troubleshooting chart, included in this chapter, provides instructions in diagnosing common malfunctions. Contact a factory-authorized service technician for troubleshooting beyond the scope of the operator.

#### A. Plugged Lines

1. To guard against plugged lines when using solid shortening, follow these guidelines:
  - a. Turn the Heater/Filter switch to HEATER 20-30 minutes before attempting a filter cycle.
  - b. At the end of the filtering cycle, let the filter bubble into the fryer through the flexible hose for about 15-30 seconds. If it is blowing bubbles, air is moving through the lines and the filter is less likely to be plugged.
  - c. When filtering is complete, drain oil or shortening from the hose.

#### B. Plugged Paper

Improper use of filter powder will slow oil return. The first indication of plugged paper is a surging, jerking movement of the hose. To correct this, review the instructions for the correct use of filter powder, and change the filter paper more frequently. When filtering several fryers prior to changing paper, ensure that excess sediment is scraped off the filter paper after filtering each frypot.

### 6.2 General Troubleshooting

The following chart contains information to assist in diagnosing the most common malfunctions with portable filtration systems. Possible solutions and/or corrective actions are given for each scenario.

If the malfunction cannot be diagnosed using the information in this section, contact your Factory Authorized Servicer for repairs.



**Use extreme care when testing electrical circuits. Live circuits will be exposed.**



**Inspection, testing and repair of gas or electrical equipment should be performed by qualified personnel.**

**PF-SERIES PORTABLE FILTRATION SYSTEMS**  
**CHAPTER 6: TROUBLESHOOTING**

---

**6.2 General Troubleshooting (cont.)**

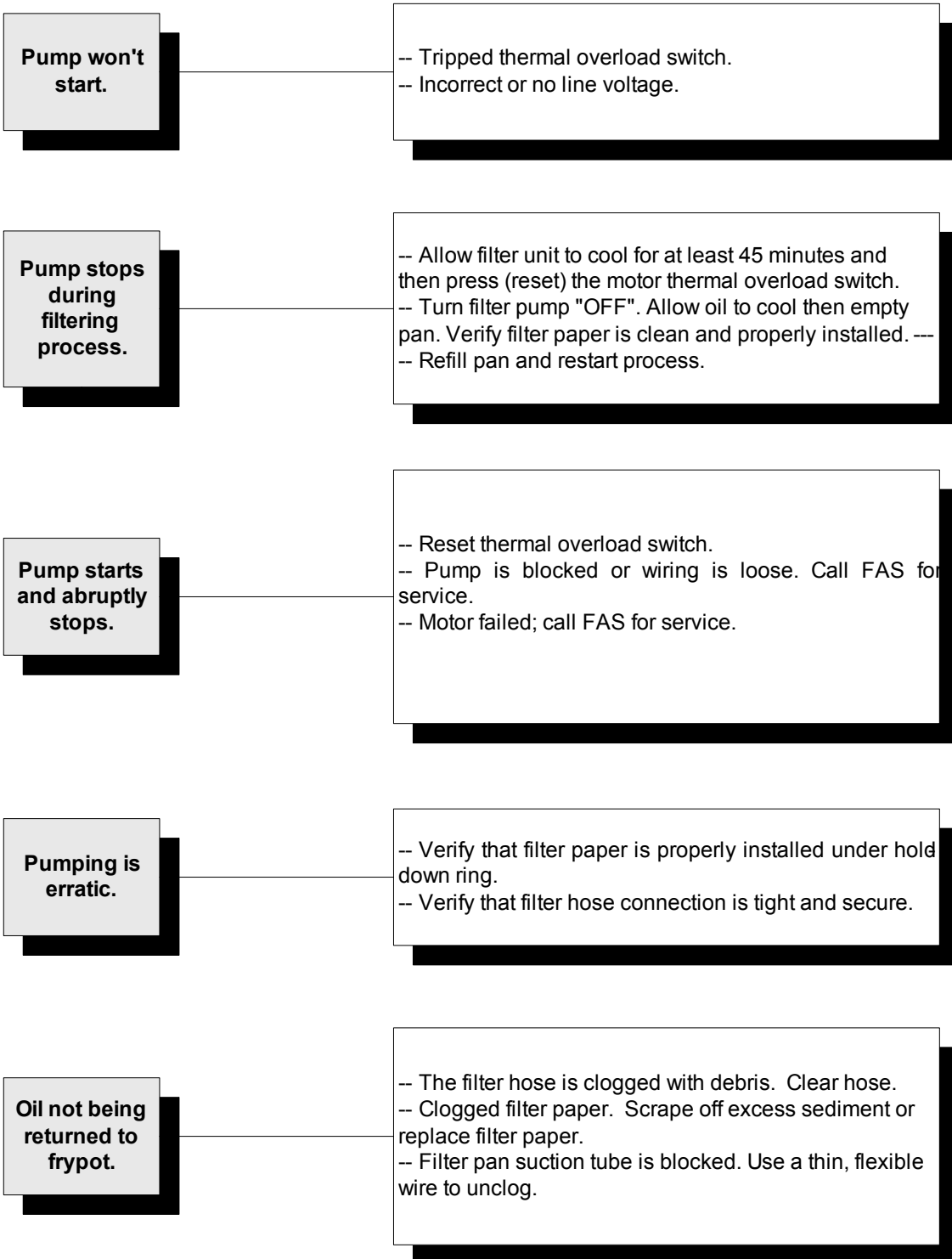

**PF-SERIES PORTABLE FILTRATION SYSTEMS**  
**CHAPTER 6: TROUBLESHOOTING**

### 6.3 Wiring Diagrams

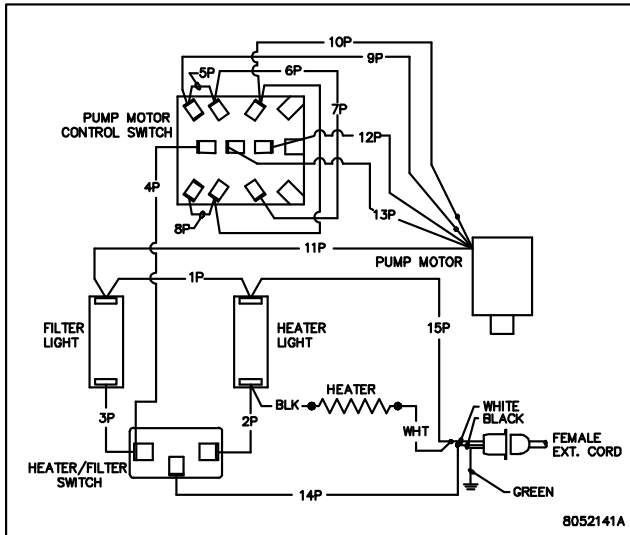

120VAC

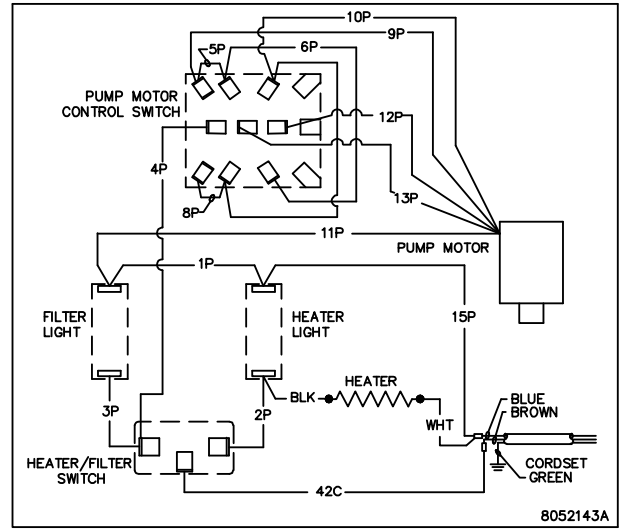

CE

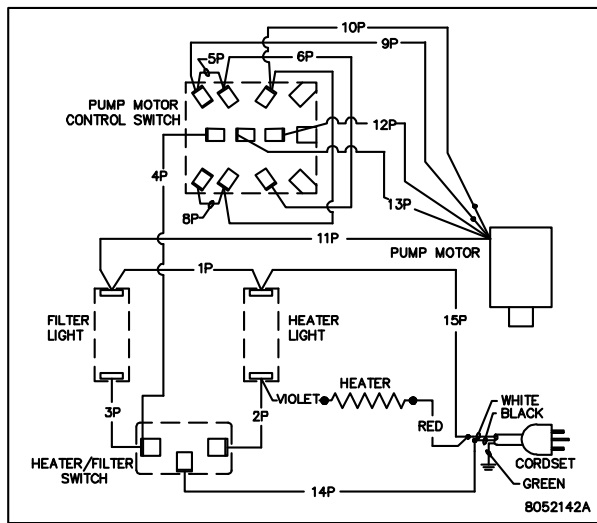

220/240VAC

**PF-SERIES PORTABLE FILTRATION SYSTEMS**  
**CHAPTER 6: TROUBLESHOOTING**

---

## 6.4 Parts List

• = used or included with portable filter.
--

Name	Part Number	Description	PF110	PF50	PF80
CASTER	<a href="#">8102805</a>	CASTER, 2" FILTER PAN	•	•	•
CASTER	<a href="#">8102806</a>	CASTER, 2" W/BRAKE FILTER PAN	•	•	•
CORDSET	<a href="#">8071224</a>	CORDSET 120V FB FLTR LJS	•	•	•
GASKET	<a href="#">8160093</a>	GASKET, PUMP/MOTOR	•	•	•
GLOVE	<a href="#">8030293</a>	GLOVE, HOT OIL NEOPRENE (PAIR)	•		•
HANDLE	<a href="#">8103508</a>	HANDLE, PORTABLE FILTER		•	
HEATER	<a href="#">8063844</a>	HEATER, STRIP 120V 25W PF		•	
HEATER	<a href="#">8071420</a>	HEATER STRIP, 120V/25W 36.0"	•		•
HEATER	<a href="#">8071472</a>	HEATER 120V 40W 56"		•	
HOSE	<a href="#">8101434</a>	HOSE ASSY, PF STANDARD	•	•	•
LID	<a href="#">8239422</a>	LID W/A, PF50 PORTABLE FILTER		•	
LID	<a href="#">8239515</a>	LID W/A, FLTR PAN MF90 DEAN PF	•		•
MOTOR	<a href="#">8073859</a>	MOTOR, 115V 60 HZ (GRAY)	•	•	•
PAN	9103756	PAN REAR 50LB PORT FLTR		•	
PAPER	8030173	PAPER, SMPL 25 SHTS 19.5X27.5		•	
PAPER	8030299	FILTER PAPER, 22X34 (25/PK)	•		•
POWDER	8030342	POWDER, (25-UNIT BOX) FILTER		•	
PUMP	8104376	PUMP, VIKING 4 GPM (CCW ONLY)	•	•	•
SCREEN	<a href="#">8122296</a>	SCREEN, SANA GRID KFC UFF50	•		•
SCREEN	<a href="#">8122300</a>	SCREEN, SANA GRID PORTABLE FLTR		•	
SWITCH	<a href="#">8071040</a>	SWITCH HESITATION TOGGLE 3PDT	•	•	•
SWITCH	<a href="#">8071041</a>	SWITCH TOGGLE SPDT	•	•	•
VALVE	<a href="#">8100430</a>	VALVE SWING CHECK 1/2" PRT FLT	•	•	•
WAND	8063825	WAND /HOSE ASSEMBLY	•	•	•
WAND	<a href="#">8101091</a>	WAND ONLY	•	•	•
	1087887	– 120V			
	1087981	– 220/240V			
	1087982	– 250V			



Foshan Manitowoc Foodservice Col, Ltd.  
No.12 Chuang Ye North Road, Song Gang Song Xia Industry Park  
Nanhai District, Foshan Guangdong, China 528234

800-551-8633  
318-865-1711

[WWW.FRYMASTER.COM](http://WWW.FRYMASTER.COM)

EMAIL: [FRYSERVICE@WELBILT.COM](mailto:FRYSERVICE@WELBILT.COM)



**WELBILT**<sup>®</sup>  
*Bringing innovation to the table*

[WWW.WELBILT.COM](http://WWW.WELBILT.COM)

Welbilt provides the world's top chefs, and premier chain operators or growing independents with industry leading equipment and solutions. Our cutting-edge designs and lean manufacturing tactics are powered by deep knowledge, operator insights, and culinary expertise. All of our products are backed by KitchenCare<sup>®</sup> – our aftermarket, repair, and parts service.

▼ CLEVELAND  
▼ CONVOTHERM<sup>®</sup>

▼ DELFIELD<sup>®</sup>  
▼ FITKITCHEN™

▼ FRYMASTER<sup>®</sup>  
▼ GARLAND

▼ KOLPAK<sup>®</sup>  
▼ LINCOLN

▼ MANITOWOC<sup>®</sup>  
▼ MERCO<sup>®</sup>

▼ MERRYCHEF<sup>®</sup>  
▼ MULTIPLEX<sup>®</sup>