



SERIES PF50 & PF50S

PF50 Series Portable Filtration Systems Service & Parts Manual



Frymaster, a member of the Commercial Food Equipment Service Association, recommends using CFESA Certified Technicians.

24-Hour Service Hotline 1-800-551-8633

08/2022



Please read all sections of this manual and retain for future reference.

Installation, maintenance, and repairs should be performed by your Frymaster Dean Factory Authorized Service Agency.

 **WARNING**

Safe and satisfactory operation of your equipment depends on its proper installation. Installation **MUST** conform to local codes, or in the absence of local codes, with the latest edition of the National Electric Code, N.F.P.A. 70.

 **WARNING**

ELECTRICAL GROUNDING INSTRUCTIONS

This filter is equipped with a three-prong, grounded plug for your protection against shock hazard and should be plugged directly into a properly grounded, three-hole receptacle. Do not cut off, remove or otherwise bypass the grounding prong on this plug.

If it is necessary to use an extension cord, it **MUST** be a three-conductor, grounded cord of 16 gauge or greater.

 **DANGER**

Do not filter more than one fry tank at a time.

Hot fluid – Do not fill above a point 1-½ inches below the OIL CONTAINER RIM.

 **WARNING**

This filter unit is not suitable for outdoor use. When operating this unit, it **MUST** be placed on a horizontal surface.

 **WARNING**

This filter unit is not suitable for installation in an area where a water jet can be used, and this appliance **MUST NOT** be cleaned with a water jet.

NOTICE:

If this filter unit is cleaned with water, disconnect the unit from power source before cleaning and thoroughly dry the filter unit before reconnecting to electrical power source.

 **DANGER**

The crumb tray (if equipped) in portable filter systems must be emptied into a fireproof container at the end of frying operations each day. Some food particles can spontaneously combust if left soaking in certain shortening material.

NOTICE:

Drawings and photos used in this manual are intended to illustrate operational, cleaning and technical procedures and may not conform to on-site management operational procedures.

NOTICE

IF, DURING THE WARRANTY PERIOD, THE CUSTOMER USES A PART FOR THIS FRYMASTER DEAN EQUIPMENT OTHER THAN AN UNMODIFIED NEW OR RECYCLED PART PURCHASED DIRECTLY FROM FRYMASTER DEAN, OR ANY OF ITS AUTHORIZED SERVICE CENTERS, AND/OR THE PART BEING USED IS MODIFIED FROM ITS ORIGINAL CONFIGURATION, THIS WARRANTY WILL BE VOID. FURTHER, FRYMASTER DEAN AND ITS AFFILIATES WILL NOT BE LIABLE FOR ANY CLAIMS, DAMAGES OR EXPENSES INCURRED BY THE CUSTOMER WHICH ARISE DIRECTLY OR INDIRECTLY, IN WHOLE OR IN PART, DUE TO THE INSTALLATION OF ANY MODIFIED PART AND/OR PART RECEIVED FROM AN UNAUTHORIZED SERVICE CENTER.



**PF50 Series Portable Filtration Systems
Service & Parts Manual**

TABLE OF CONTENTS

	Page
1. TROUBLESHOOTING/SERVICE PROCEDURES.....	1-1
2. PARTS LIST.....	2-1

PF50 SERIES PORTABLE FILTRATION SYSTEMS

CHAPTER 1: TROUBLESHOOTING/SERVICE PROCEDURES

1.1 Operating Problems

Plugged lines and plugged filter paper account for over 90 percent of filtration system malfunctions. A general troubleshooting chart, included in this chapter, provides instructions in diagnosing common malfunctions. Contact a factory-authorized service technician for troubleshooting beyond the scope of the operator.

A. Plugged Lines

1. To guard against plugged lines when using solid shortening, follow these guidelines:
 - a. Turn the Heater/Filter switch to HEATER and allow the heater to remain on for 20-30 minutes before attempting a filter cycle.
 - b. At the end of the filtering cycle, let the filter bubble into the fryer through the flexible hose for about 15-30 seconds. If it is blowing bubbles, air is moving through the lines and the filter is less likely to be plugged.
 - c. When filtering is complete, drain oil or shortening from the hose.

B. Plugged Paper

Improper use of the filter powder will cause a slow oil flow return rate. The first indication of paper plugging is a surging, jerking movement of the hose. To correct this, review the instructions for the correct use of filter powder, and change the filter paper more frequently. When filtering several fryers prior to changing paper, ensure that excess sediment is scraped off the filter paper after filtering each frypot.

1.2 General Troubleshooting

The following chart contains information to assist in diagnosing the most common malfunctions with portable filtration systems. Possible solutions and/or corrective actions are given for each scenario.

If the malfunction cannot be diagnosed using the information in this section, contact your Factory Authorized Service Agent for repairs.



Use extreme care when testing electrical circuits. Live circuits will be exposed.



Inspection, testing and repair of gas or electrical equipment should be performed by qualified personnel.

PF50 SERIES PORTABLE FILTRATION SYSTEMS
CHAPTER 1: TROUBLESHOOTING/SERVICE PROCEDURES

1.2 General Troubleshooting (cont.)

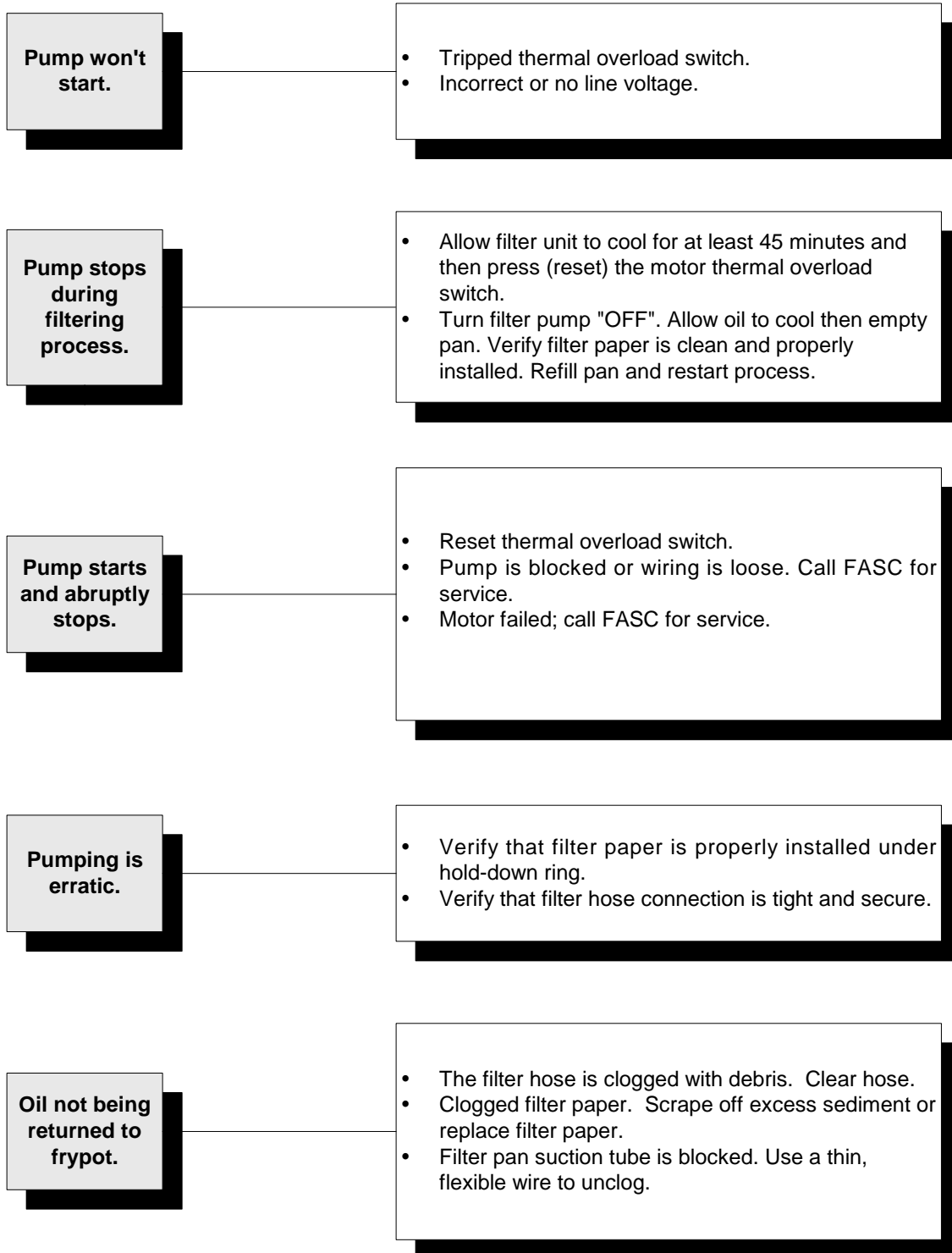

PF50 SERIES PORTABLE FILTRATION SYSTEMS
CHAPTER 1: TROUBLESHOOTING/SERVICE PROCEDURES

1.3 Wiring Diagrams

1.3.1 PF50 115V Wiring

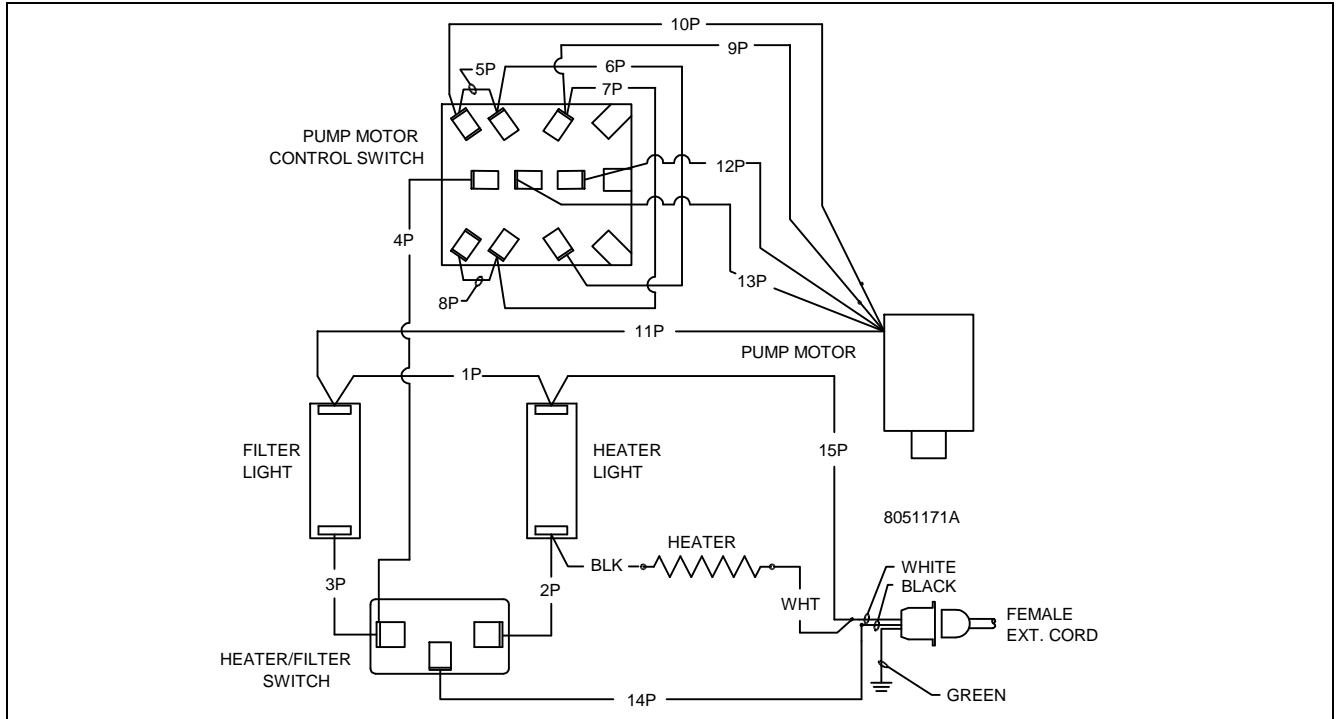

1.3.2 PF50 230V Wiring

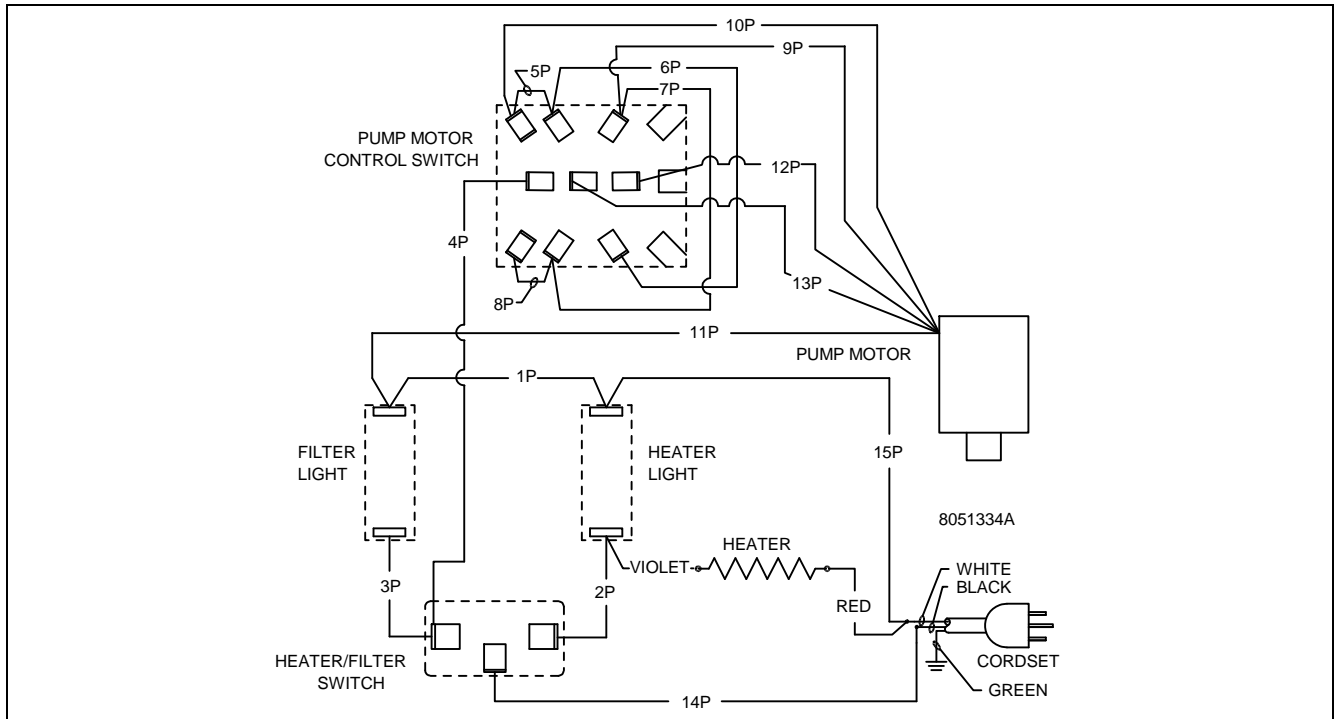

**PF50 SERIES PORTABLE FILTRATION SYSTEMS
CHAPTER 1: TROUBLESHOOTING/SERVICE PROCEDURES**

1.3.3 PF50S 115/230V Wiring

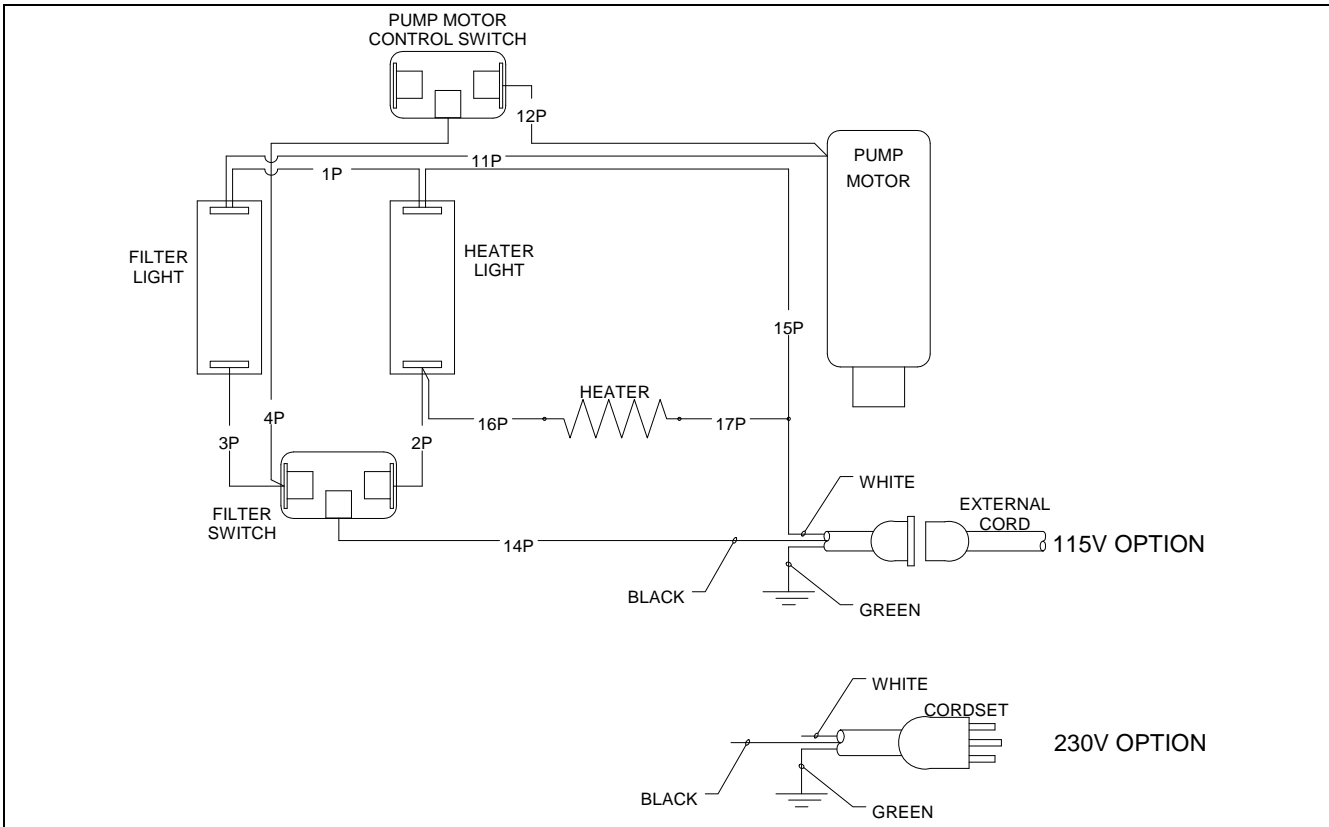

1.3.4 PF50/PF50S 115/230V Pump Motor Wiring

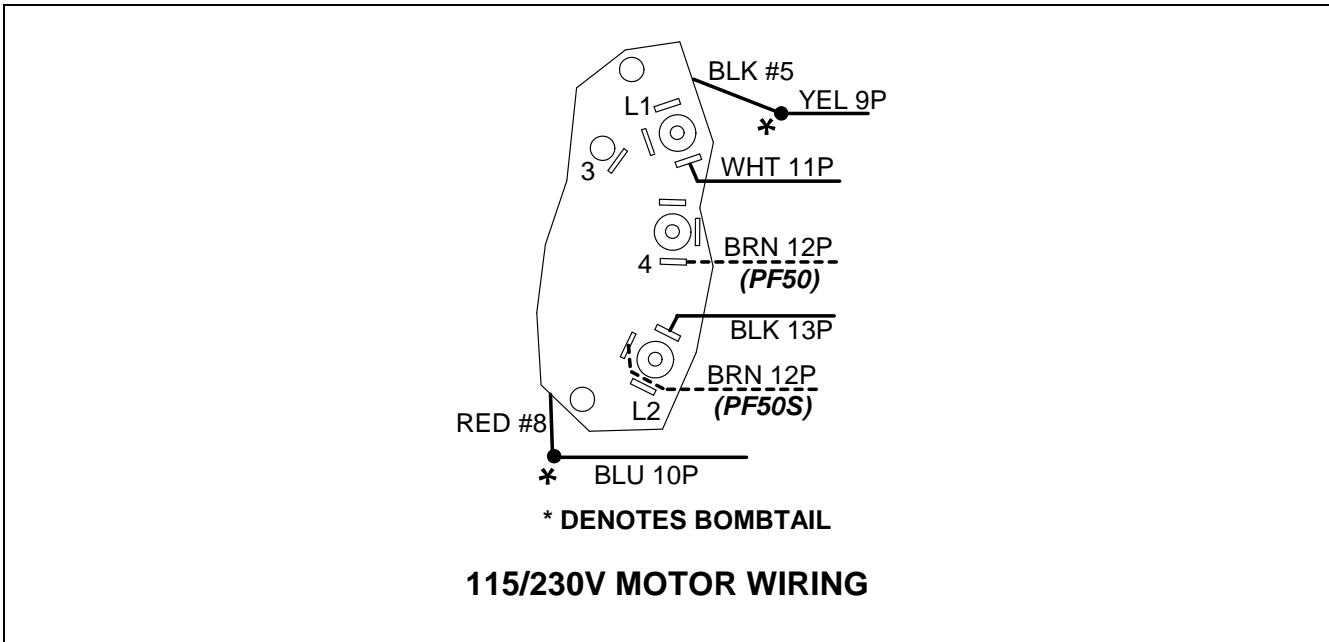

PF50 SERIES PORTABLE FILTRATION SYSTEMS
CHAPTER 1: TROUBLESHOOTING/SERVICE PROCEDURES

1.4 Service Procedures

1.4.1 Replace Lights/Switches

⚠ WARNING

Disconnect power cord from electrical power before servicing.

1. Disconnect power cord from power supply.
2. Remove four screws securing the switch panel to the control panel.
3. Lift the panel out of the control panel to access wiring.

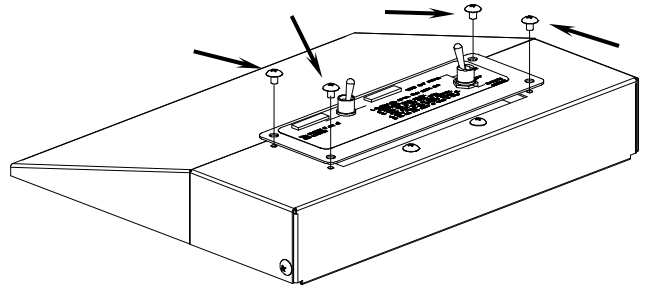

Remove screws (arrows) securing switch panel to the control panel.

4. Mark the wire locations on the defective switch/light and disconnect the wiring.
5. Install new switch or light, connect the wiring and install the switch panel. Replace the screws removed in Step 1.

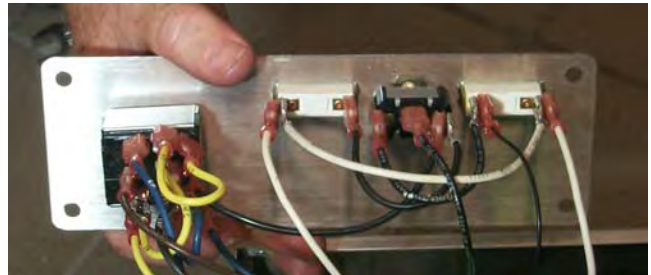

Mark wiring locations on defective switch/light before disconnecting wires.

PF50 SERIES PORTABLE FILTRATION SYSTEMS

CHAPTER 1: TROUBLESHOOTING/SERVICE PROCEDURES

1.4.2 Replace Heater Strip

1. Disconnect power cord from power supply.
2. Perform Step 2, Section 1.4.3.1, Replace Motor.
3. Remove screws securing outer panels and cord-holding bracket. Remove bracket and the panels.



Remove screws securing outer panels.

4. Turn the unit on its side and remove four nuts securing the filter pan to the base assembly. Carefully pull the filter pan away from the base to gain access to heater strip. Use care not to damage the flexlines connecting the pan to the pump.

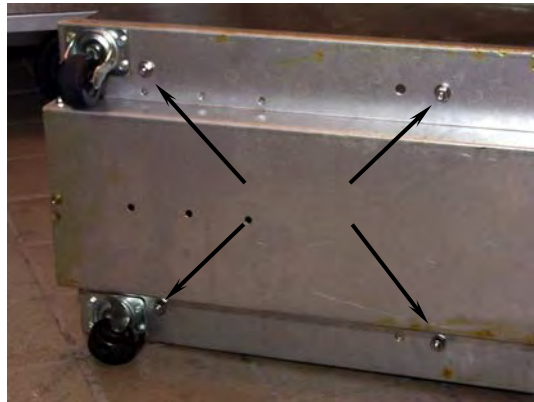

Remove four nuts securing filter pan to base (arrows).

5. Remove foil-insulating tape securing the heater strip to the pickup tube. Remove the heater strip from the pickup tube.
6. Remove the remainder of the foil-insulating tape from the flexline(s) and the pump, and then remove the heater strip. Note routing of the heater strip on the pump and flexline(s) prior to heater strip removal.



Remove foil-insulating tape to expose heater strip (arrow).

PF50 SERIES PORTABLE FILTRATION SYSTEMS

CHAPTER 1: TROUBLESHOOTING/SERVICE PROCEDURES

1.4.2 Replace Heater Strip (cont.)

7. 115VAC Filters: Disconnect the black wire from the heater indicator light on the switch panel (left, black arrow), and the white wire from the receptacle (white, white arrow).

230VAC Filters: Disconnect the red wire connected to the power supply cord (bombtail connection) and the violet wire connected to the Heater Indicator light on the switch panel.

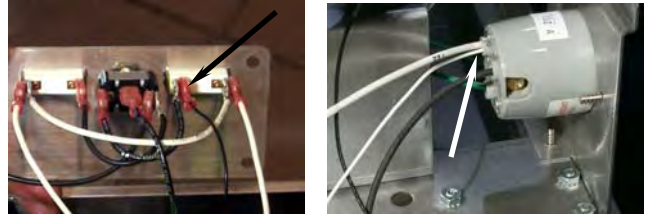

Heater strip wiring connections at switch panel and receptacle (115V heater strip shown).

8. Starting at the sump on the pan bottom, install the new heater strip, using foil tape to secure the heater to the pickup tube (see Step 3, this section).
9. Route the heater strip over the plumbing and around the pump as previously removed in Step 4.



Heater strip routing on flexlines and pump [230V PF50 (Return/Suction)].

10. Complete installation by securing strip with foil tape. Reconnect the wire connections disconnected in Step 7, this section. Reassemble filter by reversing Steps 1-3, this section.



Heater strip installed [115V PF50 (Return/Suction)].

PF50 SERIES PORTABLE FILTRATION SYSTEMS
CHAPTER 1: TROUBLESHOOTING/SERVICE PROCEDURES

1.4.3 Replace Motor/Pump

1.4.3.1 Replace Motor

1. Disconnect power cord from power supply.
2. Perform Step 2, Section 1.4.1. Remove two screws securing the handle brackets to the control panel (arrows). Do not remove the remaining handle-bracket screws. Remove remaining screws securing control panel to filter base. Lift the control panel from the base and work the switch panel through the control panel opening. Leave the switch panel wired and set aside, using care not to stretch and disconnect wiring. Remove control panel.

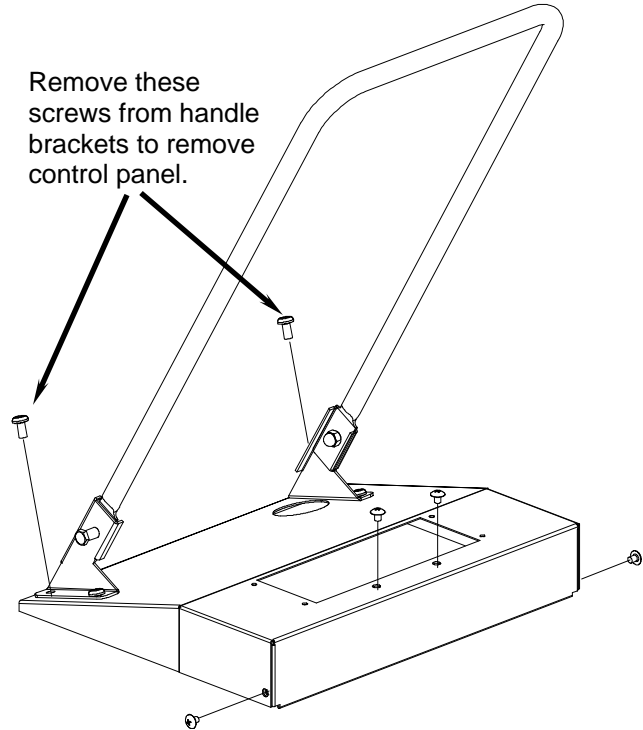

Remove screws illustrated to remove control panel. (Switch panel omitted for clarity.)

3. Remove cord-holder bracket and outer panels (see Step 3, Section 1.4.2 for reference).

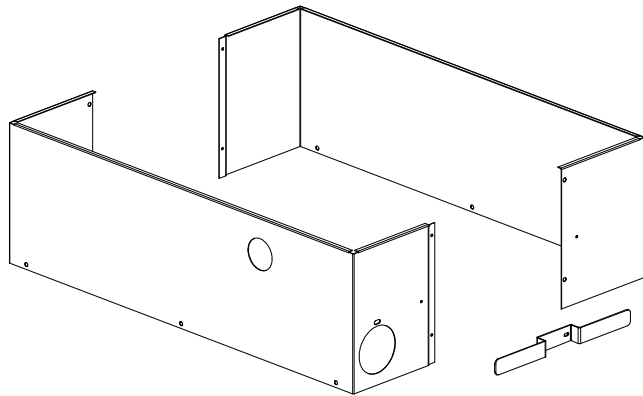

Remove cord-holder bracket and outer panels.

PF50 SERIES PORTABLE FILTRATION SYSTEMS

CHAPTER 1: TROUBLESHOOTING/SERVICE PROCEDURES

1.4.3.1 Replace Motor (cont.)

4. Remove four bolts securing the pump to the motor. Leave the plumbing connected to the pump. Use care not to damage the flex supply lines connected to the pump. Remove the pump gasket for reassembly.



Remove the four bolts securing the pump to the motor (arrows).

5. Remove six screws securing the motor bracket from the bottom of the base. Support the motor with one hand when removing the screws. Pull the motor/motor-bracket out of the cabinet and set on floor. Use care not to damage the motor wiring. Remove four bolts securing the motor to the motor-bracket. Place the replacement motor next to the old motor for ease of rewiring.

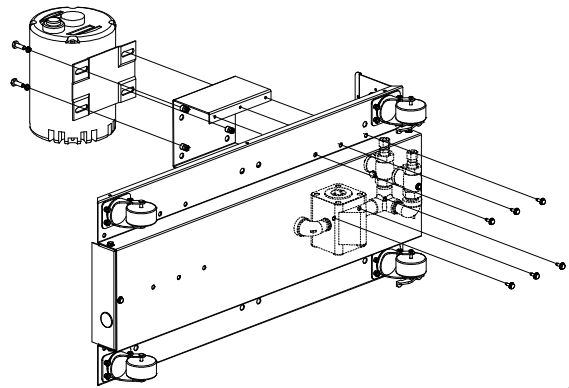

Remove six screws from the base bottom to remove the motor and motor bracket. Remove four bolts securing the motor to motor-bracket after removing the bracket from the base.

6. Remove the cover plate to access the motor wiring. Splices or bombtails are needed for two connections. Rewire the replacement motor using the wiring diagram in Section 1.3.4.
7. Complete installation of replacement motor by reversing the above steps.

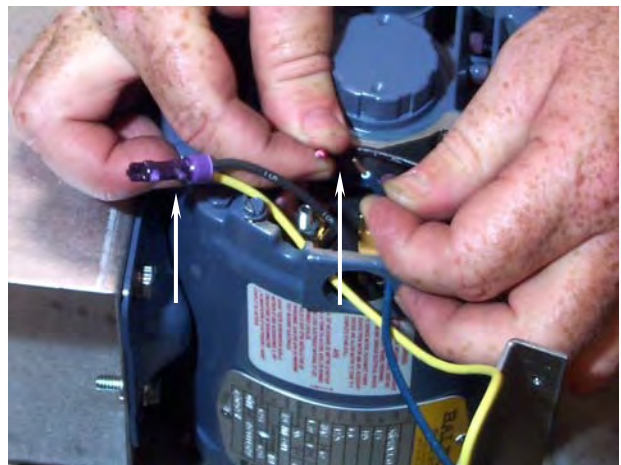

Two connections require splices or bombtails (arrows).

PF50 SERIES PORTABLE FILTRATION SYSTEMS

CHAPTER 1: TROUBLESHOOTING/SERVICE PROCEDURES

1.4.3.2 Replace Pump

1. Disconnect power cord from power supply.
2. Perform Steps 2 and 3, Section 1.4.3.1, Replace Motor.
3. Remove foil insulation tape and heater strip from pump and flex lines. Remove the heater strip from the pump and disconnect flexlines from the check valve connections.



Remove foil insulation tape covering the heater strip and remove heater strip from the pump and flexlines. Disconnect the flexlines from the check valve connections.

4. Remove pipefittings from pump before removing pump from motor.

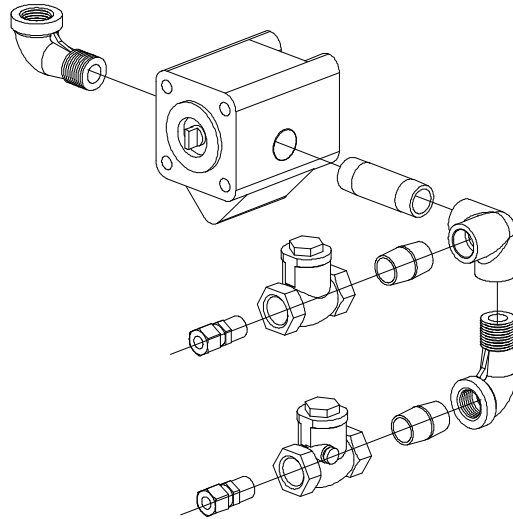

Remove pipefittings from pump before removing pump from motor.

5. Remove four bolts securing the pump to the motor. Remove the pump and pump gasket. Fit new pump gasket and install new pump on motor. Torque pump bolts to 15-foot pounds. Do not over-tighten the bolts.

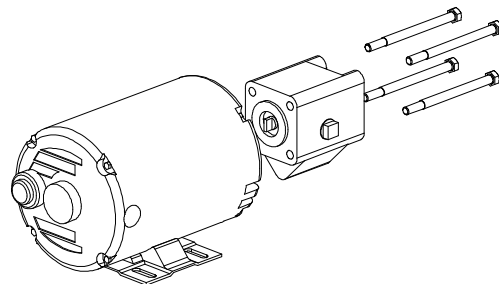

Remove four bolts securing the pump to the motor. Remove pump and gasket from motor.

6. Reinstall all removed components during pump removal by reversing the above steps.

PF50 SERIES PORTABLE FILTRATION SYSTEMS

CHAPTER 1: TROUBLESHOOTING/SERVICE PROCEDURES

1.4.3.3 Replace Wand Hose

1. Disconnect power cord from power supply.
2. Remove cord-holder bracket and outer panels (see Step 3, Section 1.4.2 for reference).

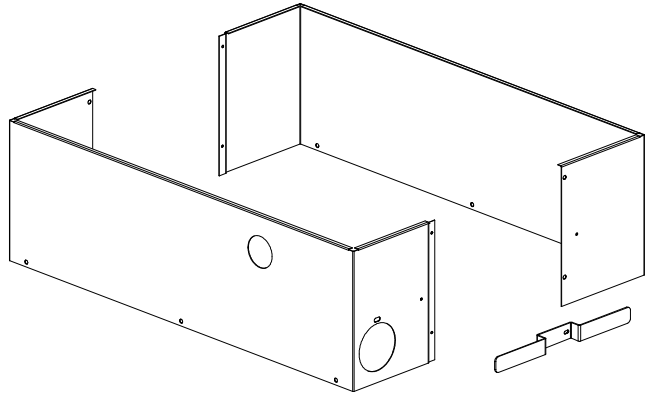

Remove cord-holder bracket and outer panels.

3. Unscrew the hose fitting with an open-end wrench from the elbow on the pump.
4. Install the new hose, using care not to cross-thread the connections. Use an approved pipe sealant on the threads to ensure a leak-proof connection. **DO NOT OVER-TIGHTEN THE CONNECTION.**
5. Replace the outer panels and the cord-holder bracket.



Remove hose fitting (arrow) with an open-end wrench. Use pipe sealant when installing new hose.

PF50 SERIES PORTABLE FILTRATION SYSTEMS

CHAPTER 2: PARTS LIST

2.1 PF50 Parts List

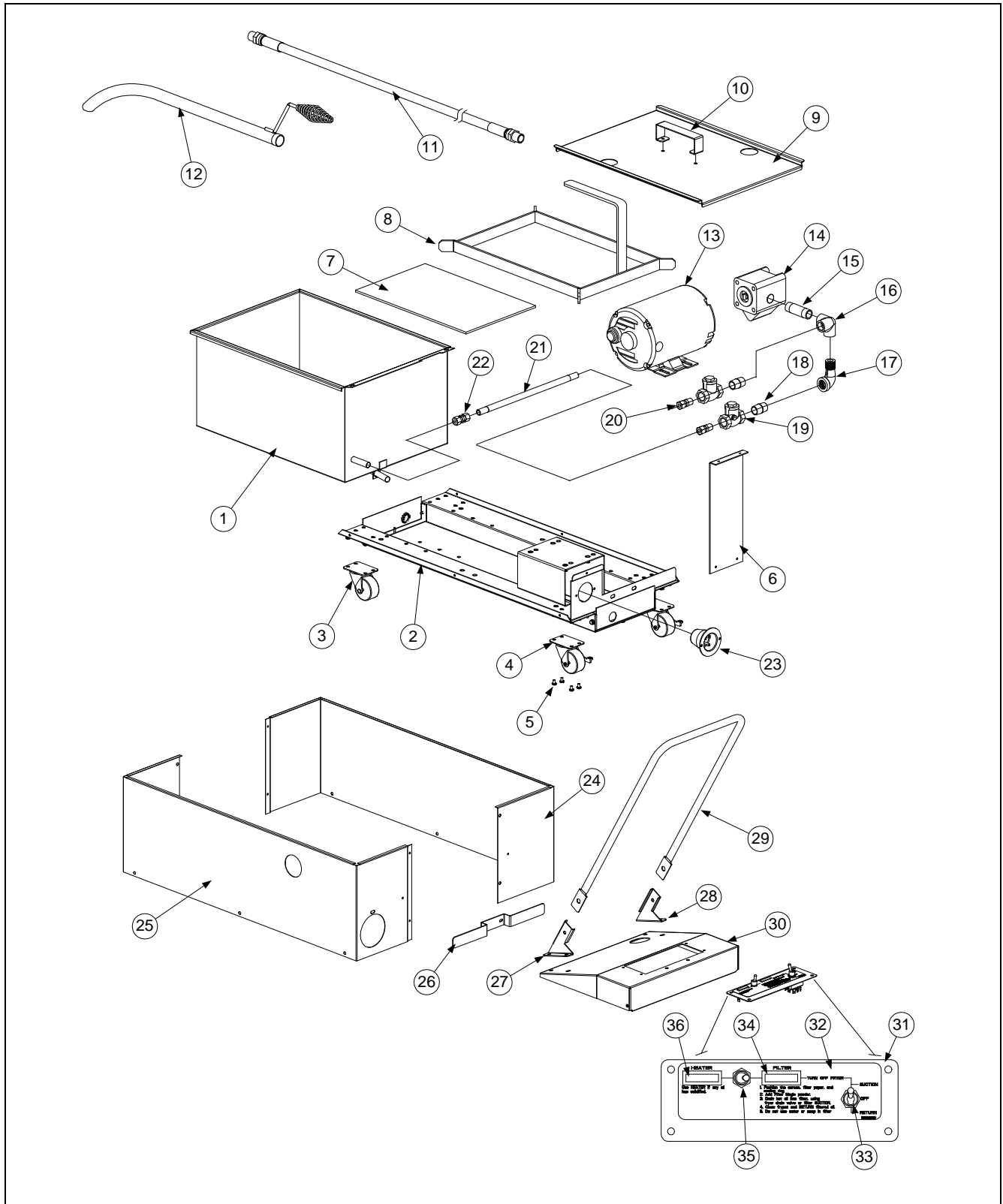

**PF50 SERIES PORTABLE FILTRATION SYSTEMS
CHAPTER 2: PARTS LIST**

2.1 PF50 Parts List (cont.)

Item	Part #	Description
1	823-2813	Pan, Filter (For units with only one pickup tube use P/N 823-2814)
2	806-5223SP	Base Assembly (Includes items 3 & 4)
3	810-2805	Caster, 2"- Swivel (Without Brake)
4	810-2806	Caster, 2"- Swivel (With Brake)
5	809-0475	Screw- 10-32 x 5/16 Hex
6	900-3751	Bracket, Standoff
7	900-8825	Screen, Filter Paper Support
*	803-0170	Paper, Filter "19.5 x 27.5" 100 sheets
*	803-0002	Powder, Filter - 80 individual packets
8	823-0889	Ring, Hold-down
9	910-3757	Lid, Filter Pan
*	823-5950	Crumb basket
10	826-0993SP	Handle, Pan Lid (Includes Screws, Nuts, Washers and Threadlocking Compound)
*	826-1379	Screw, #10 x ½" Phillips (Lid Handle) (Qty. of 10)
*	809-0184	Washer, Lock - #10 (Lid Handle)
*	809-0020	Nut, Cap- 10-24 (Lid Handle)
11	810-1434	Hose Assembly - All PF50 (Can order items 11 & 12 as assembly P/N 806-3825SP)
12	810-1091	Nozzle Assembly - All PF50 (Can order items 11 & 12 as assembly P/N 806-3825SP)
13		Motor, Filter Pump
	826-1712	115V 60HZ 1/3 HP (Includes Motor and Gasket)
	826-1270	230V 50/60HZ 1/3 HP (Includes Motor and Gasket)
14	826-1264	Pump, Filter - 4GPM (Includes Pump and Gasket)
15	813-0265	Nipple, ½ x 2-½" NPT BM
16	813-0331	Elbow, With Side Outlet- ½" NPT BM
*	806-3844	Heater Strip, 120V 40W
17	813-0165	Elbow, Street- ½" NPT BM
18	813-0022	Nipple, ½" x Close NPT BM
19	810-0430	Valve, Swing Check - ½"
20	813-0544	Union, ½ NPT x ½" Flexline Hose
21	810-1435	Flexline, ½ x 12" S/S Hose
22	813-0545	Union, ½ x ½" Flexline Hose
*	826-1467	Hose Replacement Kit, PF Series Before 07/97
* Not Illustrated		

**PF50 SERIES PORTABLE FILTRATION SYSTEMS
CHAPTER 2: PARTS LIST**

2.1 PF50 Parts List (cont.)

Item	Part #	Description
23	807-1219	Receptacle, 115V 3-Wire (120V Domestic Units Only)
*	807-1224	Cord, Power - 3-Wire 115V
*	807-0154	Cord, Power - 3-Wire 230V
24	910-8587	Panel, Outer - Left Side- All PF50 Filters
25	910-8586	Panel, Outer - Right Side- PF50 115V Domestic Only
*	210-0795	Panel, Outer - Right Side- PF50 230V Export Only
26	910-3788	Holder, Power Cord - All PF50
27	912-2616	Bracket, Handle- Right – All PF50
28	911-2616	Bracket, Handle- Left – All PF50
*	826-1380	Screw, ¼-20 x ½" Slotted Head (For Handle Bracket) (Qty. of 5)
29	810-3508	Handle, Portable Filter – All PF50
*	826-1389	Bolt, ¼-20 x ¾" Hex Head (Qty. of 10)
*	810-0219	Spacer, Handle Bolt
*	809-0047	Nut, Cap- ¼-20 High Profile S/S
30	824-0403	Panel, Control – All PF50
31	910-0982	Panel, Switch – All PF50
32	802-1302	Label, Switch Panel - PF50 Filters Only
*	802-1438	Label, Switch Panel - PF50S Filters Only
33	807-1040	Switch, Toggle- 3-Way, <u>PF50 Filters Only</u> (PF50S Filters, Use Item #35)
34	807-1060	Light, Indicator- Red Lens (Filter Indicator Light)
35	807-1041	Switch, Toggle- 2-Way SPDT - All PF50
36	807-1061	Light, Indicator- White Lens (Heater Indicator Light)
* Not Illustrated		



FRYMASTER
8700 LINE AVENUE, SHREVEPORT, LA 71106-6800

800-551-8633
318-865-1711

WWW.FRYMASTER.COM

EMAIL: FRYSERVICE@WELBILT.COM



Welbilt offers fully-integrated kitchen systems and our products are backed by KitchenCare® aftermarket parts and service. Welbilt's portfolio of award-winning brands includes Cleveland™, Convotharm®, Crem®, Delfield®, Frymaster®, Garland®, Kolpak®, Lincoln®, Merco®, Merrychef® and Multiplex®.

Bringing innovation to the table • welbilt.com

©2022 Welbilt Inc. except where explicitly stated otherwise. All rights reserved. Continuing product improvement may necessitate change of specifications without notice.

Part Number FRY_SP_8196982 08/2022