



PF95LP Series Portable Filtration Systems Installation & Operation Manual

Please read all sections of this manual and retain for future reference

PARTS LIST
INCLUDED



Frymaster, a member of the Commercial Food Equipment Service Association, recommends using CFESA Certified Technicians.

Service 1-318-865-1711



8 1 9 7 5 1 0

Installation, maintenance, and repairs should be performed by your Frymaster Factory Authorized Servicer.

 **WARNING**

Safe and satisfactory operation of your equipment depends on its proper installation. Installation **MUST** conform to local codes, or in the absence of local codes, with the latest edition of the National Electric Code, N.F.P.A. 70.

 **WARNING**

ELECTRICAL GROUNDING INSTRUCTIONS

This filter is equipped with a three-prong, grounded plug for your protection against shock hazard and should be plugged directly into a properly grounded, three-hole receptacle. Do not cut off, remove or otherwise bypass the grounding prong on this plug.

If it is necessary to use an extension cord, it **MUST** be a three-conductor, grounded cord of 16 gauge or greater.

 **WARNING**

This appliance is not intended for use by children under the age of 16 or persons with reduced physical, sensory or mental capabilities, or lack of experience and knowledge, unless they have been given supervision concerning use of the appliance by a person responsible for their safety. Do not allow children to play with this appliance.

 **WARNING**

Use caution and wear appropriate safety equipment to avoid contact with hot oil or surfaces that may cause severe burns or injury.

 **DANGER**

Do not filter more than one fry tank at a time.

Hot fluid – Do not fill above a point 1-½ inches below the OIL CONTAINER RIM.

 **WARNING**

This filter unit is not suitable for outdoor use. When operating this unit, it **MUST** be placed on a horizontal surface.

 **WARNING**

This filter unit is not suitable for installation in an area where a water jet can be used, and this appliance **MUST NOT** be cleaned with a water jet.

NOTICE:

If this filter unit is cleaned with water, disconnect the unit from power source before cleaning and thoroughly dry the filter unit before reconnecting to electrical power source.

 **DANGER**

The crumb tray (if equipped) in portable filter systems must be emptied into a fireproof container at the end of frying operations each day. Some food particles can spontaneously combust if left soaking in certain shortening material.

NOTICE:

Drawings and photos used in this manual are intended to illustrate operational, cleaning and technical procedures and may not conform to on-site management operational procedures.

NOTICE

IF, DURING THE WARRANTY PERIOD, THE CUSTOMER USES A PART FOR THIS FRYMASTER DEAN EQUIPMENT OTHER THAN AN UNMODIFIED NEW OR RECYCLED PART PURCHASED DIRECTLY FROM FRYMASTER DEAN, OR ANY OF ITS AUTHORIZED SERVICE CENTERS, AND/OR THE PART BEING USED IS MODIFIED FROM ITS ORIGINAL CONFIGURATION, THIS WARRANTY WILL BE VOID. FURTHER, FRYMASTER DEAN AND ITS AFFILIATES WILL NOT BE LIABLE FOR ANY CLAIMS, DAMAGES OR EXPENSES INCURRED BY THE CUSTOMER WHICH ARISE DIRECTLY OR INDIRECTLY, IN WHOLE OR IN PART, DUE TO THE INSTALLATION OF ANY MODIFIED PART AND/OR PART RECEIVED FROM AN UNAUTHORIZED SERVICE CENTER.



PF95LP Series Portable Filtration Systems
Installation & Operation Manual

TABLE OF CONTENTS

	Page #
1. INTRODUCTION.....	1-1
2. IMPORTANT INFORMATION.....	2-1
3. INSTALLATION INSTRUCTIONS.....	3-1
4. FILTER OPERATION.....	4-1
5. CLEANING AND MAINTENANCE.....	5-1
6. TROUBLESHOOTING.....	6-1
7. PARTS LIST.....	7-1

PF95LP SERIES PORTABLE FILTRATION SYSTEMS

CHAPTER 1: INTRODUCTION

1.1 Parts Ordering/Service Information

Place parts orders directly with your local Frymaster/Dean Factory Authorized Servicer (FAS). Your nearest Frymaster FAS is accessible at www.frymaster.com or you can contact the Frymaster Service Department at 1-800-24-FRYER or 1-318-865-1711.

To help speed your order, the following information is required:

Model Number		Type	
Serial Number			
Optional Features			
Item Part Number		Quantity Needed	

1.2 Service Information

Call the 1-800-551-8633 or (318) 865-1711 Service Hotline number for the location of your nearest Factory Authorized Servicer. Always give the model and serial numbers of your filter unit. Also, identify if your unit is supplied with or without a heater.

To assist you more efficiently, the following information will be needed:

Model Number		Type	
Serial Number			
Optional Features			
Nature of Problem:			

Additional information (i.e. oil temperature at filter time, time of day and other pertinent information) may be helpful in solving your service problem.

PF95LP SERIES PORTABLE FILTRATION SYSTEMS
CHAPTER 1: INTRODUCTION

1.3 After Purchase

In order to improve service, have the following chart filled in by the Authorized Service Technician who installed this equipment.

Authorized Service Technician/FAS	
Address	
Telephone/Fax	
Model Number	
Serial Number	

1.4 Safety Information

Before attempting to operate your unit, read the instructions in this manual thoroughly.

Throughout this manual, you will find notations enclosed in double-bordered boxes similar to the ones below.

 **CAUTION**

CAUTION boxes contain information about actions or conditions that *may cause or result in a malfunction of your system.*

 **WARNING**

WARNING boxes contain information about actions or conditions that *may cause or result in damage to your system,* and which may cause your system to malfunction.

 **DANGER**

DANGER boxes contain information about actions or conditions that *may cause or result in injury to personnel,* and which may cause damage to your system and/or cause your system to malfunction.

PF95LP SERIES PORTABLE FILTRATION SYSTEMS
CHAPTER 1: INTRODUCTION

1.5 Service Personnel

1.5.1 Definitions

A. Qualified and/or Authorized Operating Personnel

1. Qualified/authorized operating personnel are those who have carefully read the information in this manual and have familiarized themselves with the equipment functions, or have had previous experience with the operation of equipment covered in this manual.

B. Qualified Installation Personnel

1. Qualified installation personnel are individuals, or firms, corporations, or companies that, either in person or through a representative, are engaged in and are responsible for the installation of electrical appliances. Qualified personnel must be experienced in such work, be familiar with all electrical precautions involved, and have complied with all requirements of applicable national and local codes.

C. Qualified Service Personnel

1. Qualified service personnel are those who are familiar with Frymaster/Dean equipment and have been authorized by Frymaster/Dean to perform service on Frymaster/Dean equipment. All authorized service personnel are required to be equipped with a complete set of service parts manuals and stock a minimum amount of parts for Frymaster/Dean equipment.
Failure to use qualified service personnel will void the Frymaster/Dean warranty on your equipment.

PF95LP SERIES PORTABLE FILTRATION SYSTEMS

CHAPTER 2: IMPORTANT INFORMATION

2.1 General

PF95LP portable filters can be used with a variety of Frymaster fryers, as well as other manufacturers' equipment. Oil capacity is approximately 105 pounds. Unit specifications are listed below.

Model	Unit Height (inches)	Unit Width (inches)	Unit Length (inches)	Tank Height (inches)	Oil Capacity (pounds)
PF95LP	24	18	33 ½	9	105

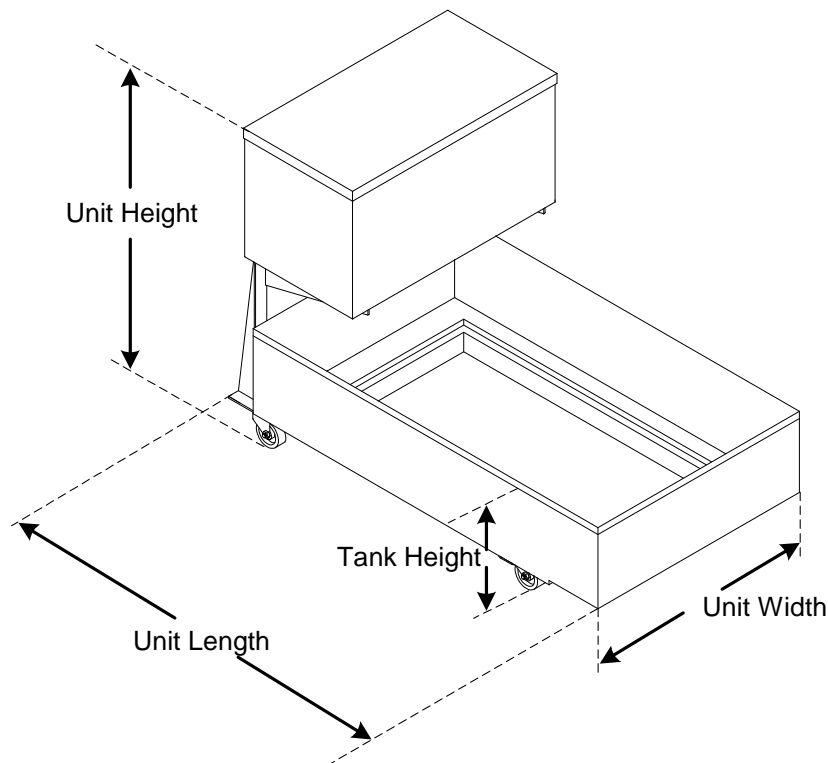

PF95LP Series filter unit dimensions (unit and tank heights are measured from bottom of casters to top of unit and tank, respectively).

PF95LP SERIES PORTABLE FILTRATION SYSTEMS

CHAPTER 2: IMPORTANT INFORMATION

2.1 General (cont.)

Oil or shortening is gravity-drained from the fryer into the filter, and then filtered through filter paper. Filter powder, which enhances the filtering process, is distributed over the paper prior to filtering.

All units are shipped completely assembled with accessories packed inside the filter pan. All units are adjusted, tested and inspected at the factory before shipment.

WARNING

The on-site supervisor is responsible for ensuring that operators are made aware of the inherent dangers of operating a hot oil filter system, particularly the aspects of oil filtration, and draining/cleaning procedures.

An ON/OFF switch activates/deactivates the filter pump, and a 7-amp (120V), or 5-amp (230V) circuit breaker switches the power OFF if an overload occurs. An internal backup thermal-overload switch on the pump-motor provides additional protection. Remove the 6-Phillips head screws and remove the motor housing to access the thermal overload reset switch.

NOTE: *If the circuit breaker is triggered, depress the reset button to activate the circuit after the failure has been detected and repaired.*

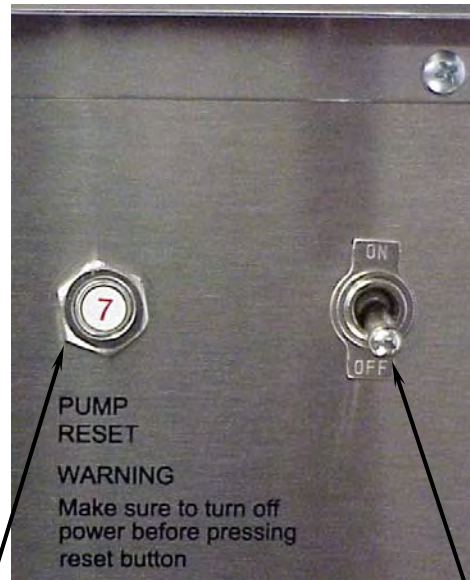

7-Amp circuit breaker

On/Off Switch

NOTE: An additional thermal overload switch is on the filter motor. Remove the 6-Phillips head screws and then remove the motor housing cover to access the thermal overload switch.

2.2 Rating Plate

Information on the rating plate includes model and serial numbers, as well as electrical requirements. The rating plate is located on the back housing, near the electrical receptacle. Have the rating plate information handy when communicating with the factory about a unit or requesting special parts or information. Without rating plate information, proper identification of the unit cannot be confirmed.

PF95LP SERIES PORTABLE FILTRATION SYSTEMS
CHAPTER 2: IMPORTANT INFORMATION

2.3 Pre-Installation

NOTE: Failure to use qualified service personnel will void the Frymaster/Dean warranty.

- A. Standards: Use of this filter unit must be in accordance with all applicable state and local codes.
- B. Electrical Connections: Domestic PF95 filter units require a 115V 60 Hz., 15 amp electrical supply. International/CE units require 230V 50 Hz., 7 amp electrical supply. Units are equipped with a grounded male receptacle for use with a 16-3 SJT power cord set. If an extension cord is required, it must be a three-conductor, grounded power cord of at least 16 gauge.

2.4 Unpacking the Filter System

Ensure the container is upright. Unpack the filter carefully and remove all accessories from the carton. Do not discard or misplace parts and/or accessories; they will be needed for filter setup and operation. Any accessories or starter kits included with the unit will be packaged inside the filter tank.

After unpacking, immediately check the equipment for visible signs of shipping damage. If such damage has occurred, contact the carrier and file the appropriate freight claims. Do not contact the factory, as the responsibility of shipping damage is between the carrier and dealer or end-user.

If your equipment arrives damaged:

- a. File claim for damages immediately – Regardless of extent of damage.
- b. Visible loss or damage – Be sure this is noted on the freight bill or express receipt and is signed by the person making the delivery.
- c. Concealed loss or damage – If damage is unnoticed until equipment is unpacked, notify freight company or carrier immediately, and file a concealed damage claim. This should be done within 15 days of date of delivery. Retain the shipping container for inspection.

NOTE: Frymaster does not assume responsibility for damage or loss incurred in transit.

PF95LP SERIES PORTABLE FILTRATION SYSTEMS

CHAPTER 3: FILTER PREPARATION

3.1 Assembling The Filter System

On initial installation and before each use, remove all loose parts from the filter, wash the filter pan and all accessories in hot, soapy water and dry thoroughly.

⚠ WARNING!

Water or boil-out solution MUST not be allowed to drain into the filter pan or filter system. Irreversible damage will result if water is allowed into the system, and the warranty will be voided.

PF95LP Series portable filtration systems use a filter support grid, one sheet of filter paper and a hold-down ring to secure the filter paper in place.

3.1.1 Filter Paper Configuration

See illustration for proper assembly.

1. Filter Pan Cover
2. Hold-Down Ring
3. Filter Paper (one sheet)
4. Screen/Support Grid
5. Filter Pan Assembly

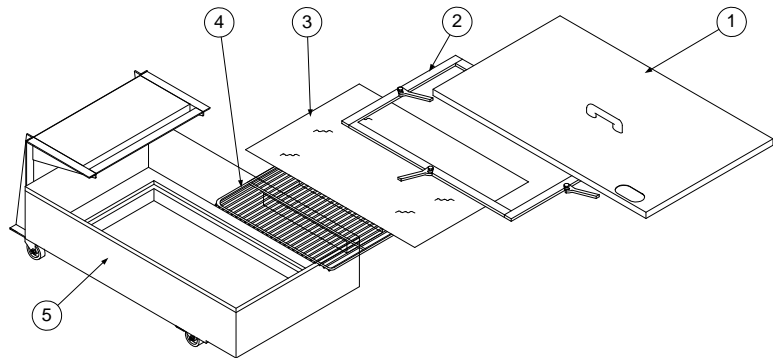

- A. First, place the support grid in the bottom of filter pan.
- B. Place one sheet of filter paper on top of the support grid. Ensure the paper evenly covers the filter pan bottom.
- C. Position the hold-down ring on top of the filter paper and latch the hold-down ring and filter paper securely against the filter pan bottom, forming a tight seal.
- D. Sprinkle 8 ounces of filter powder over the filter paper, distributing the powder as evenly as possible. If filtering a second frypot immediately after the first, add only 4 ounces of filter powder for the second filtering.
- E. Place the crumb catcher screen (if applicable) in the filter pan. Allow the crumb catcher screen to rest on the top edges of the hold-down ring.
- F. Place filter pan cover onto the filter pan assembly.

PF95LP SERIES PORTABLE FILTRATION SYSTEMS
CHAPTER 3: FILTER PREPARATION

3.1.1 Filter Paper Configuration (cont.)

- G. Position filter under the fryer drainpipe to gravity drain the fryer. Lock the rear casters to prevent filter from moving out of position during the filtering process.



PF95LP portable filter positioned correctly next to fryer drain valve, with rear casters locked in place.

PF95LP SERIES PORTABLE FILTRATION SYSTEMS

CHAPTER 4: FILTER OPERATION

4.1 General

PF95LP Series portable filters are designed to operate primarily as an independent filter unit. Operations always start by ensuring the unit is properly plugged in, then rolling the filter to the fryer to be filtered. The filter works directly under the fryers' drain valves. The general layout of a PF95LP Series portable filter with major components identified is illustrated below.

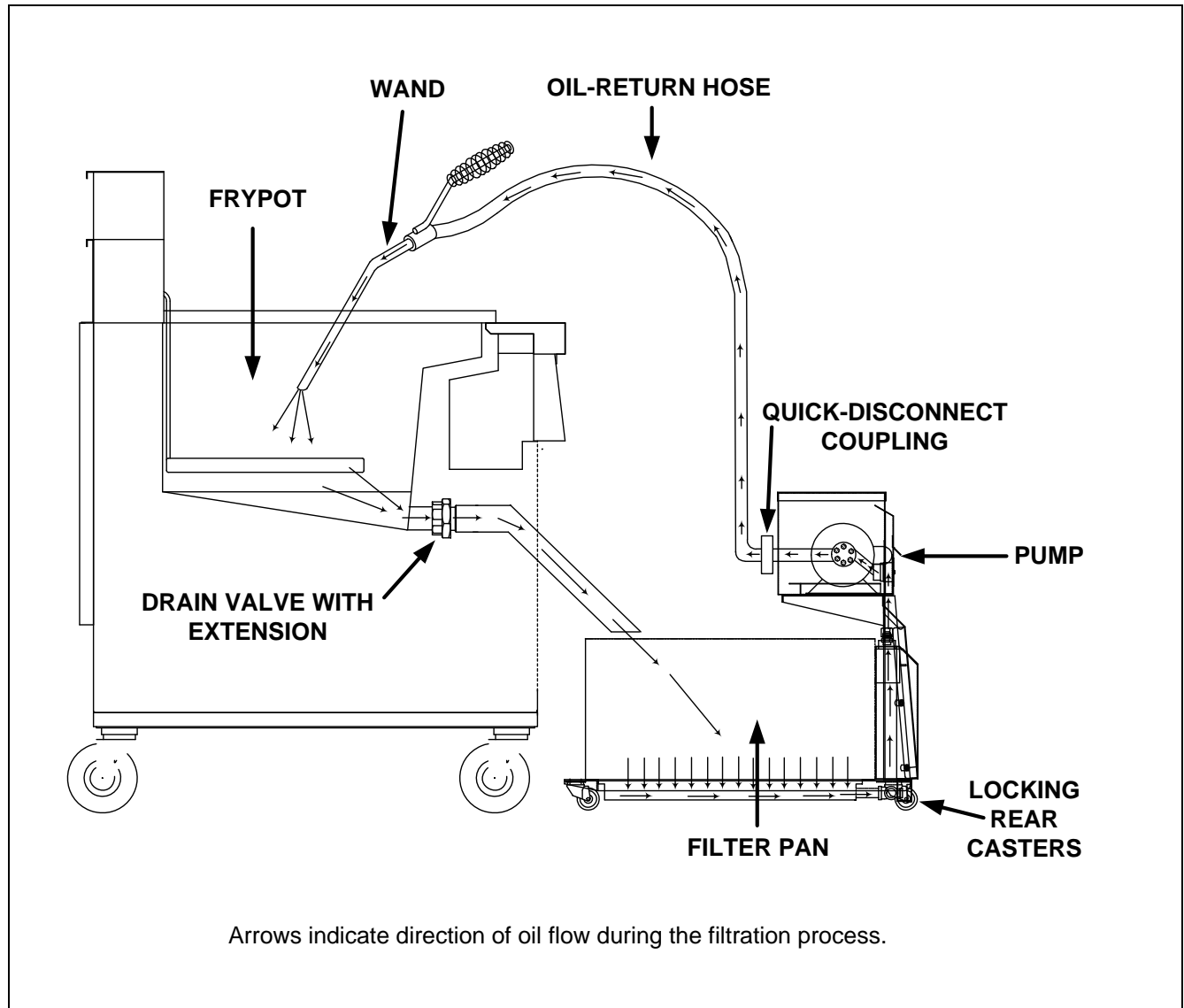

PF95LP SERIES PORTABLE FILTRATION SYSTEMS

CHAPTER 4: FILTER OPERATION

4.2 Filtering Tools

These tools are not required, but are recommended to make the filtering task easier.

- A. Measuring Cup: Used to measure eight ounces by volume of filter powder.
- B. Scrub Brush: To clean sediment and residue from the filter pan and frypot.
- C. Appropriate Clothing.

4.3 Filter Preparation

1. Position the PF95LP portable filter next to the fryer. Remove filter pan lid and position filter unit under frypot drain-valve extension.
2. Ensure the filter power switch is in "OFF" position prior to connecting to power supply.
3. Plug power cord into electrical outlet. The filter unit is ready for filtering. After filtering, follow instructions in Section 4.4, Changing Filter Paper.

DANGER

The crumb tray (if equipped) in portable filter systems must be emptied into a fireproof container at the end of frying operations each day. Some food particles can spontaneously combust if left soaking in certain shortening material.

4.4 Changing Filter Paper

Filter paper should be replaced after each filter session, and most certainly at the beginning of each workday. If filter paper is replaced once per day, excess sediment should be scraped from the filter paper after each frypot is filtered (see photo). Use care not to tear the paper when scraping off sediment. Filter at closing if possible. This ensures the oil is at proper filtering temperature.

Note: If filtering at closing, remove and discard the used filter paper in a fireproof container when filter operations are complete. Wash all components in soapy water and dry completely.



If filtering more than one frypot with the same filter paper, scrape excess sediment from the filter paper after each filtering.

PF95LP SERIES PORTABLE FILTRATION SYSTEMS CHAPTER 4: FILTER OPERATION

4.4 Changing Filter Paper (cont.)

Remove and replace the paper as follows:

1. Remove filter cover. Place the hose wand in the wand holster, located on the left side of the pan (arrow).
2. Open the locking latches of the hold-down ring and lift the ring out of the filter tank.



Removing hold-down ring. Note location of wand holster (arrow).

3. Roll both ends of the filter paper into the center, ensuring no sediment falls out, and discard.



Removing dirty filter paper from pan.

PF95LP SERIES PORTABLE FILTRATION SYSTEMS
CHAPTER 4: FILTER OPERATION

4.4 Changing Filter Paper (cont.)

4. Remove and check the filter paper support screen for cleanliness and clean if necessary.



Removing paper support screen from pan.

5. Check the filter-pan for cleanliness and clean if necessary; check the drain ports at the bottom rear of the filter pan and clear any solidified shortening from the opening (black arrow). Also ensure vent hole on top of tube is clear of shortening and/or debris (white arrow).

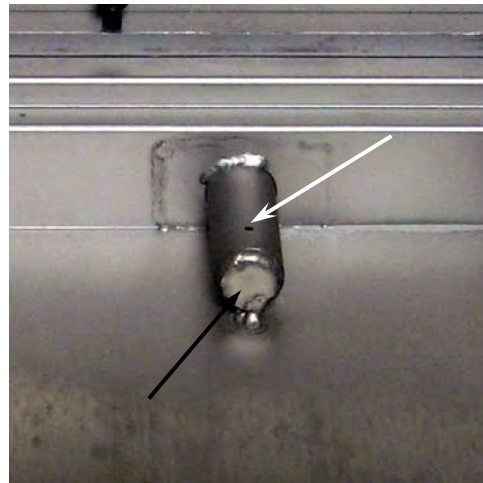

Solidified shortening can build-up in the nipple-pipe assembly (black arrow).

6. Replace the filter paper support screen and place a new sheet of filter paper on top of the screen.



Placing new sheet of filter paper over paper support screen.

PF95LP SERIES PORTABLE FILTRATION SYSTEMS
CHAPTER 4: FILTER OPERATION

4.4 Changing Filter Paper (cont.)

7. Replace the hold-down ring and secure by locking latches in place.



Secure the hold-down ring latches to lock filter paper in place.

8. Measure 8 ounces of filter powder and distribute evenly over the paper surface.



Evenly distribute 8 ounces of filter powder over the filter paper surface.

9. Replace filter pan cover. The filter is ready for operation.

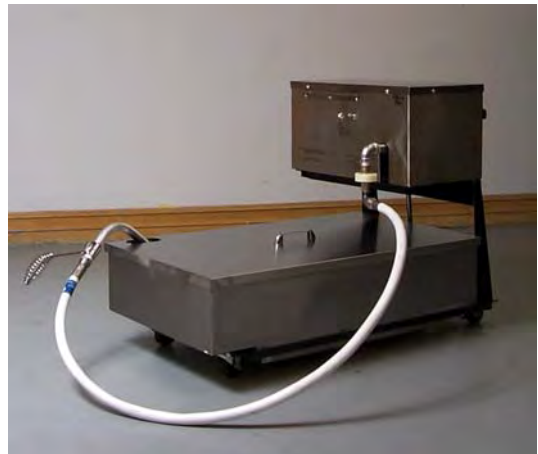

Filter unit ready for filtering operations.

PF95LP SERIES PORTABLE FILTRATION SYSTEMS
CHAPTER 4: FILTER OPERATION

4.5 Unit Operation

1. When filtering, follow these steps:
2. Follow the appropriate instructions in Sections 4.3 and 4.4 to prepare the filter unit for operation.
3. Position the filter unit under the fryer drain valve extension prior to draining fryer.
4. Turn the fryer main power switch to the "OFF" position.

⚠ DANGER

Do not leave filter unit unattended during the filtering operation. Pressurized oil moving through the lines can cause the flexible return hose and wand assembly to pop loose and spray hot oil.

Avoid spilling hot oil onto floor surfaces. When draining fryer into filter, never exceed the maximum capacity of the filter pan.

5. Open the fryer door and place the filter in the proper position under the fryer drain valve extension (see photo below). Lock rear casters to prevent filter movement during the filtering process.



**PF95LP SERIES PORTABLE FILTRATION SYSTEMS
CHAPTER 4: FILTER OPERATION**

4.5 Unit Operation (cont.)

⚠ DANGER

The oil temperature of the fryer to be filtered should be approximately 350°F (175°C). Position drain handles properly prior to operating the filter unit. Failure to do this can result in burn injury to the user.

6. Open the drain-valve and allow the frypot oil to drain into the filter pan.



Frypot draining into filter pan. Ensure oil is at operating temperature before opening drain valve.

7. With the oil return wand in frypot, turn filter switch "ON" to begin pumping clean oil into the fryer. Allow the oil to recycle through the fryer for a few seconds to wash out sediment on the bottom of the frypot before closing the drain valve.



Use the nozzle to rinse sediment and debris from the frypot during the filtering process ("U" units only).

Note: The oil return wand can also be mounted in the wand holster inside the pan, for extended filtering periods (polishing) prior to refilling frypot. NEVER LEAVE THE FILTER SYSTEM UNATTENDED WHILE FILTERING!

PF95LP SERIES PORTABLE FILTRATION SYSTEMS
CHAPTER 4: FILTER OPERATION

4.5 Unit Operation (cont.)

8. When filtering is complete, close the drain valve handle. It takes approximately 5 to 7 minutes for the filter to pump all the oil back into the fryer.



9. Allow the pump to run for 10-15 seconds after air starts to flow through the wand, before shutting off the filter. Clearing residual shortening or oil from the return lines reduces the likelihood of clogged lines.



NOTE: *After filtering, scrape off debris and sediment accumulated on the filter paper and discard into a fireproof container.*

⚠ CAUTION

If using solid shortening, the return hose must be completely drained after filtering, or the shortening will solidify and plug the hose or oil return lines as it cools.

NOTE: *If filtration operations problems are encountered during use, please refer to Chapter 6 in this manual.*

PF95LP SERIES PORTABLE FILTRATION SYSTEMS

CHAPTER 5: PREVENTATIVE MAINTENANCE

5.1 General

Cleaning operations fall into three general categories:

- Wiping unit clean, interior and exterior, after each filter session.
- Cleaning, changing filter paper and preparing the unit for the next day's business.
- Weekly cleaning to remove oil deposits and other particles that were previously missed.

 **WARNING**

Do not use water jets to clean this equipment. To do so will damage the unit and void the warranty.

 **WARNING**

Never operate the filter unit unless cooking oil is at operating temperature.

5.2 Each Filter Use

Each time the portable filter is used:

- Wash down the insides of the filter pan with hot oil during the filtering process. **DO NOT** allow excessive residue buildup to occur inside the filter pan.
- Change filter paper after each filter session or at the end of the day. Scrape sediment from filter paper after each frypot is filtered within a filter session. Do not filter more than three fryers per one sheet of filter paper.
- Wipe up any oil which may have splashed or spilled.
- Wipe all exterior surfaces of the filter unit.

 **WARNING**

Do not run water or boil-out solution through the portable filter. Doing so will cause irreparable damage to the pump, and void the warranty.

PF95LP SERIES PORTABLE FILTRATION SYSTEMS
CHAPTER 5: PREVENTATIVE MAINTENANCE

5.3 Daily- Close Of Business

At the close of a working day, filter the oil in all fryers. When the last fryer is finished, follow these steps:

1. Ensure the flexible hose and pump lines are clear by running the filter pump for an additional 10–15 seconds after air bubbles start coming from the oil return line. Then drain the flexible hose.
2. Discard the filter paper after use.
3. Remove the filter pan cover and hold-down ring assembly, then remove the filter paper and filter support screen.
4. Wash all filter components with soapy water and rinse.
5. Dry all filter parts and filter pan thoroughly before reassembling.
6. Check all fittings at the rear of the filter unit; ensure that all fittings are properly tightened.

 **DANGER**

The crumb tray (if applicable) in portable filter systems must be emptied into a fireproof container at the end of frying operations each day. Some food particles can spontaneously combust if left soaking in certain shortening material.

5.4 Weekly

Follow the same procedure as for "Daily", with these additional steps:

- Wash the filter pan with hot, soapy water and a brush. Dry and reassemble with new filter paper.
- Clean thoroughly under, around, and behind the fryers and filtering area.
- Do not operate motor/pump until all traces of water have been removed from the pan. Under no circumstances should water or boil-out solution be allowed to enter the pump housing; irreparable damage will result, and all warranties will be voided.
- Check the connections of the inlet lines and tighten if lines become loose or start to leak oil.

PF95LP SERIES PORTABLE FILTRATION SYSTEMS

CHAPTER 6: TROUBLESHOOTING

6.1 Operating Problems

Plugged lines and plugged filter paper account for over 90 percent of filtration system malfunctions. A general troubleshooting chart included in this chapter provides systematic instructions to assist the operator in diagnosing common malfunctions. Contact a factory-authorized service technician for troubleshooting beyond the scope of the operator.

A. Plugged Lines

1. To guard against plugged lines when using solid shortening, follow these guidelines:
 - a. At the end of the filtering cycle, let the filter bubble into the fryer through the flexible hose for about 10-15 seconds. If it is blowing bubbles, air is moving through the lines and the filter is less likely to be plugged.
 - b. When filtering is complete, disconnect the flexible line and hang it up to drain.

B. Plugged Paper

Improper use of the filter powder will cause a slow oil flow return rate. The first indication of paper plugging is a surging, jerking movement of the hose. To correct this, review the instructions for the correct use of filter powder, and change the filter paper more frequently. When filtering several fryers prior to changing paper, ensure that excess sediment is scraped off the filter paper after filtering each frypot. If plugged paper remains a problem, review the chart in section 6.2 for proper diagnosis.

6.2 General Troubleshooting

The following chart contains information to assist the user in diagnosing the most common malfunctions with portable filtration systems. Possible solutions and/or corrective actions are given for each scenario.

If the malfunction cannot be diagnosed using the information in this section, contact your Factory Authorized Service Agent for repairs.



Use extreme care when testing electrical circuits. Live circuits will be exposed.



Inspection, testing and repair of gas or electrical equipment should be performed by qualified personnel.

PF95LP SERIES PORTABLE FILTRATION SYSTEMS
CHAPTER 6: TROUBLESHOOTING

6.2 General Troubleshooting (cont.)

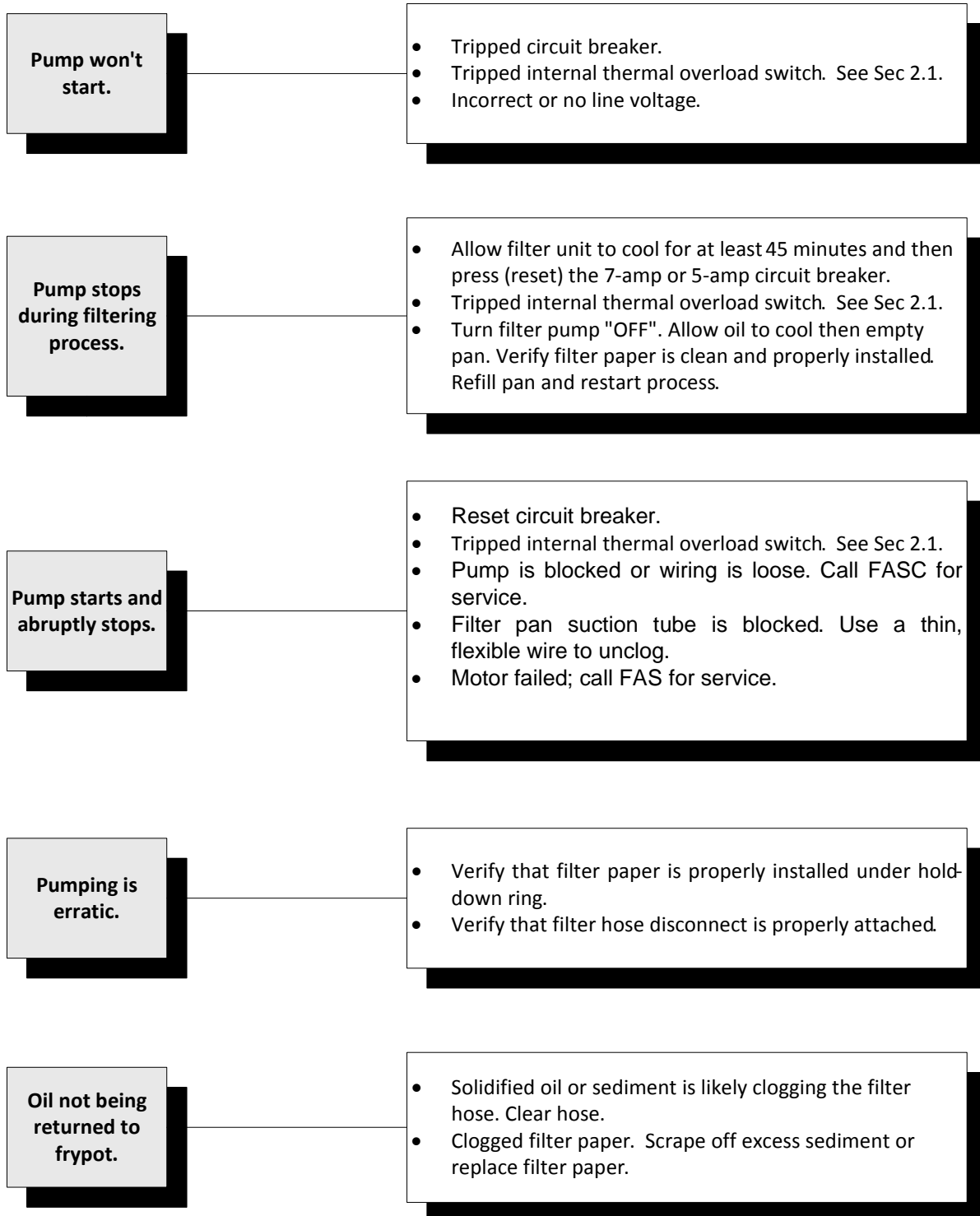

PF95LP SERIES PORTABLE FILTRATION SYSTEMS

CHAPTER 6: TROUBLESHOOTING

6.3 Wiring Diagrams

6.3.1 PF95LP 120V Wiring

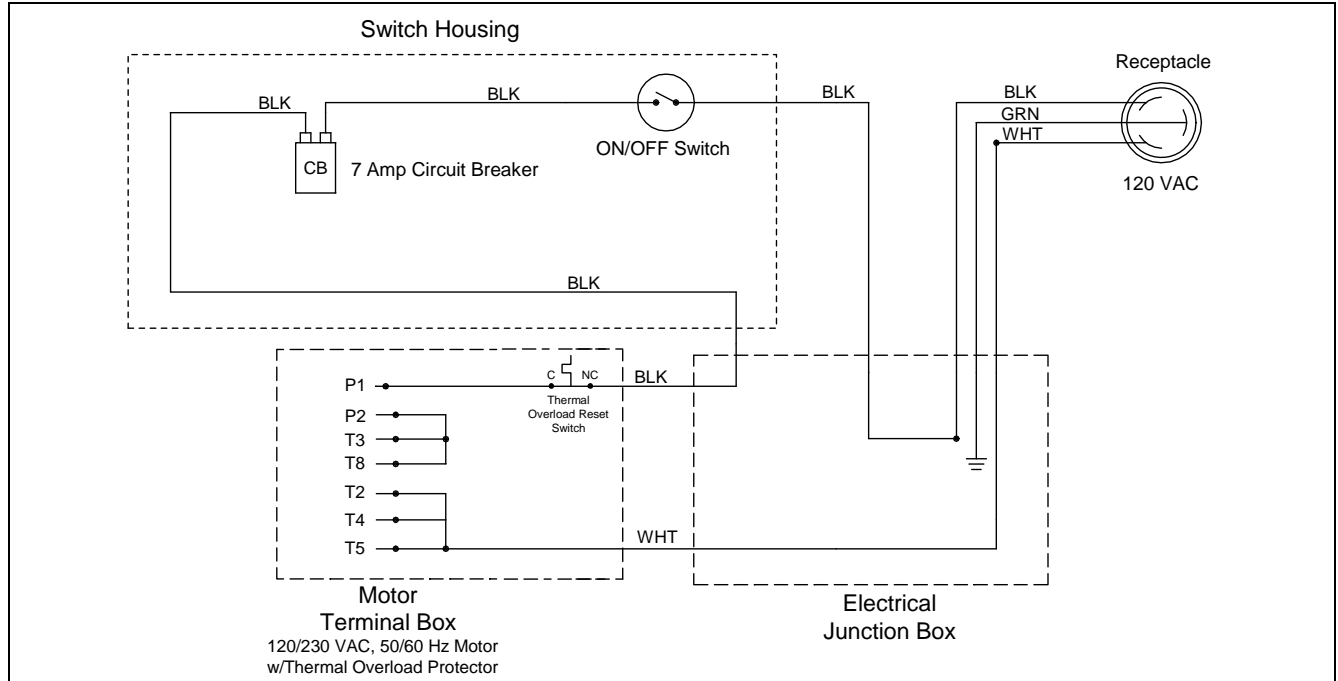

6.3.2 PF95LP 230V Wiring

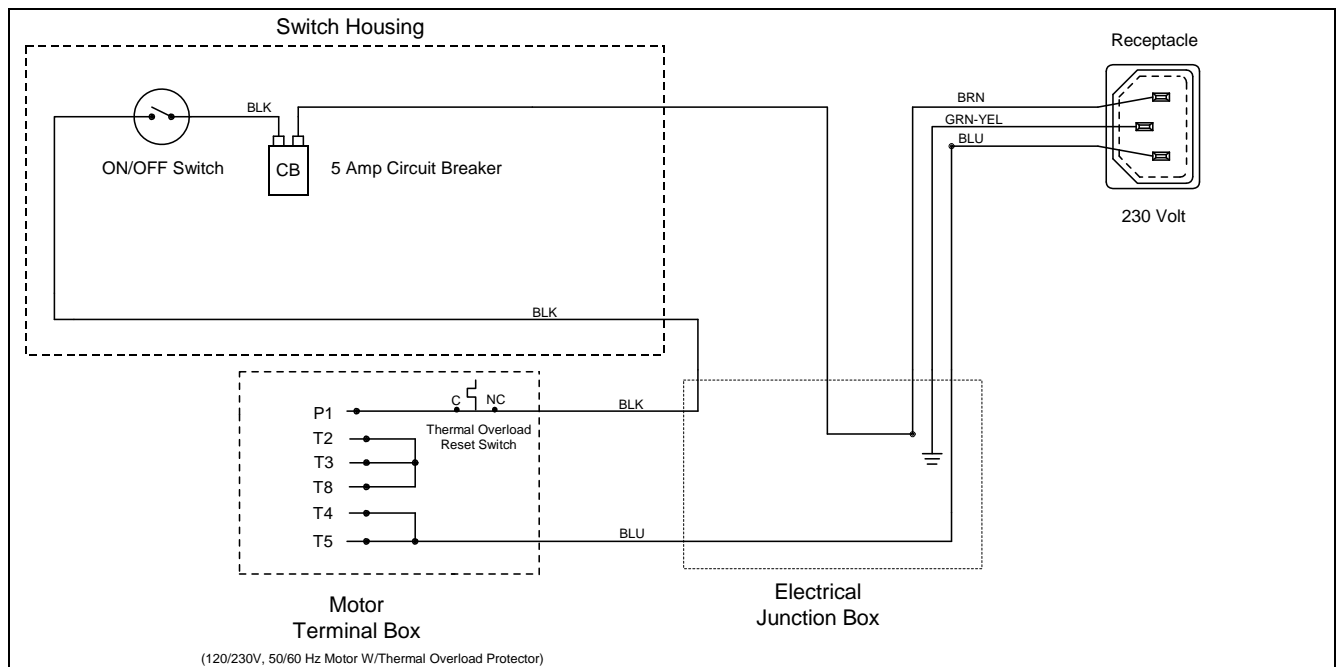

PF95LP SERIES PORTABLE FILTRATION SYSTEMS

CHAPTER 7: PARTS LIST

7.1 Main Components

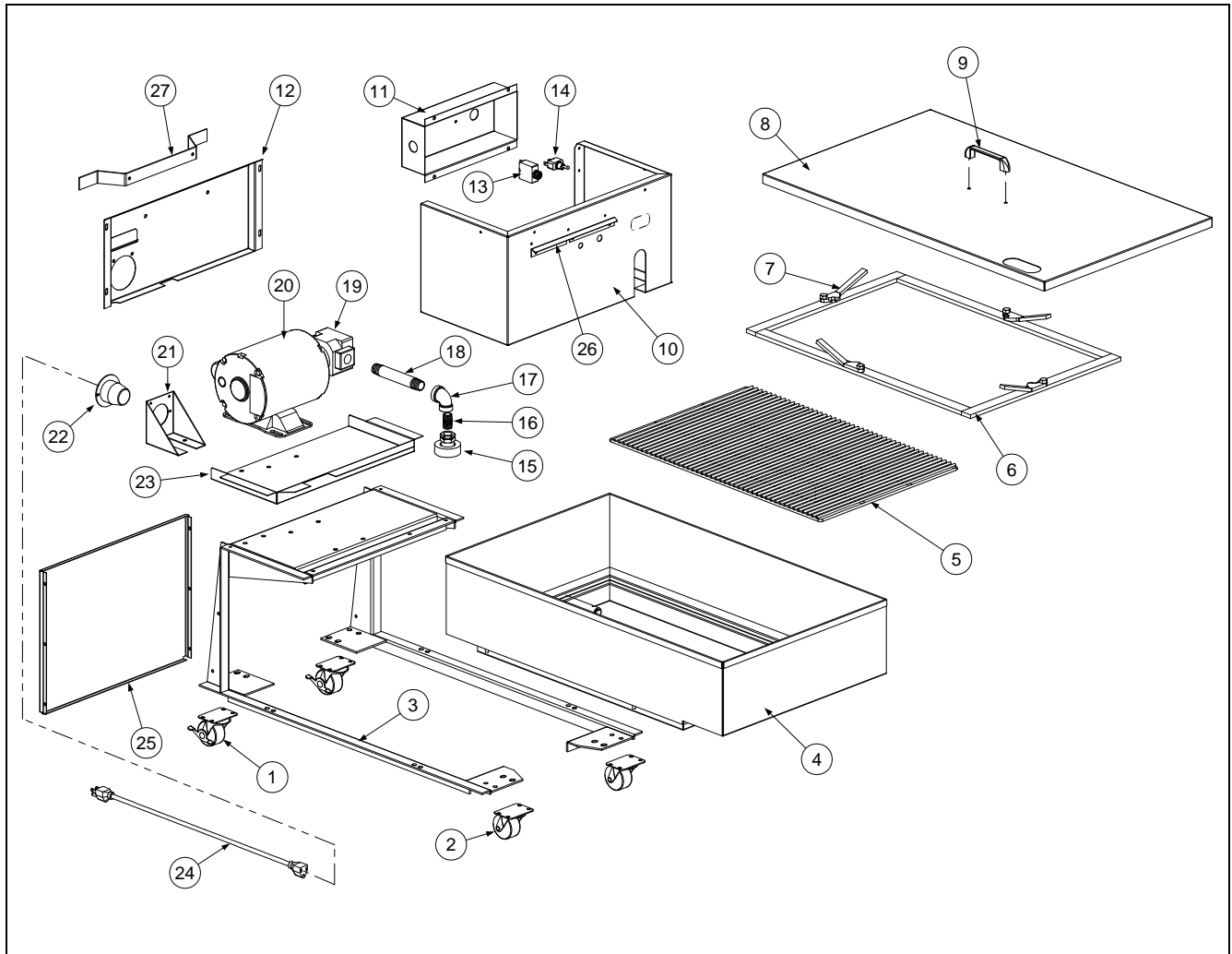

Item	Part #	Description
1	824-1089	Caster, Rear- Locking- 2"
2	810-2141	Caster, Front- Swivel- 2"
3	823-3613	Frame, Filter PF95 Series
4	823-3680	Pan, Filter- PF95 Series
*	809-0070	Nut, ¼-20 Hex SS (Filter Pan to Frame- 4 Required)
*	809-0190	Washer, .625 x .275 x 40 Flat SS (Use With 809-0070)
5	823-8435	Screen, Paper Support- PF95 Series
* Not Illustrated		

PF95LP SERIES PORTABLE FILTRATION SYSTEMS
CHAPTER 7: PARTS LIST

7.1 Main Components (cont.)

Item	Part #	Description
6	106-2032SP	Ring, Hold-down Assy- 4-Handle PF95 Series
*	810-2289	Ring, Hold-down Assy- 6-Handle PF95 Series
7	810-2108	Handle, Latch (For Hold-Down Rings)
*	809-0808	Screw, Shoulder- 5/16-18 x 0.803" (For Latch Handles)
8	210-1883	Lid, Filter Pan- PF95 Series
9	810-2105	Handle, Chrome- Pan Lid
*	809-0918	Screw, #10-24 x ½" (Pan Lid Handle)
*	809-0191	Washer, ¼" Spring
10	823-3684	Housing, Top- Motor/Component
11	200-1542	Housing, Switch
12	823-3590	Back, Motor Housing
13	807-3577	Breaker, Circuit- 7 Amp (120VAC)
*	807-3538	Breaker, Circuit- 5 Amp (230VAC)
14	807-1041	Switch, Toggle- On/Off SPST- "U" Series Only
15	106-1831SP	Disconnect, Quick Assembly- 3/8"
16	813-0772	Nipple, 3/8" NPT x Close- SS
17	813-0691	Elbow, ½ x 3/8" Chrome-Plated
18	813-0761	Nipple, ½ NPT x 5" SS
19	810-2252	Pump, Filter- 5GPM
20	810-2100	Motor, Filter Pump- 115/230V 1/3 HP
*	807-3689	Harness, Wire- Receptacle To Motor
*	807-3752	Harness, Wire- Motor To Switch/Circuit Breaker
21	210-2955	Bracket, Receptacle Mount- 120V Units Only
*	210-3818	Bracket, Receptacle Mount- 230V Units Only
22	807-1219	Receptacle, 120 VAC Three-Wire
*	807-3795	Receptacle, 230 VAC Three-Wire
23	200-1588	Tray, Pump and Motor
24	807-1224	Cordset, 120V Filter
*	807-3831	Connector, Export Plug- 230V (Cord Not Included)
25	210-2978	Cover, Rear
26	210-1570	Cover, Switch/Circuit Breaker
27	200-2956	Bracket, Power Cord Storage
* Not Illustrated		

THIS PAGE INTENTIONALLY LEFT BLANK



Welbilt Foshan Foodservice Co, Ltd.
No.12 Chuang Ye North Road, Song Gang Song Xia Industry Park
Nanhai District, Foshan Guangdong, China 528234

800-551-8633

318-865-1711

WWW.FRYMASTER.COM

EMAIL: FRYSERVICE@WELBILT.COM



Welbilt offers fully-integrated kitchen systems and our products are backed by KitchenCare® aftermarket parts and service. Welbilt's portfolio of award-winning brands includes **Cleveland™, Convotherm®, Crem®, Delfield®, fitkitchen®, Frymaster®, Garland®, Kolpak®, Lincoln®, Merco®, Merrychef® and Multiplex®.**

Bringing innovation to the table • welbilt.com

©2022 Welbilt Inc. except where explicitly stated otherwise. All rights reserved. Continuing product improvement may necessitate change of specifications without notice.

Part Number FRY_IOSP_8197510 10/2022