



Shortening Disposal Unit
(SDU 50, 90, 100 and BKSDU)
Installation, Operation, Service and Parts Manual

Frymaster[®]



Frymaster, a member of the Commercial Food Equipment Service Association, recommends using CFESA Certified Technicians.

24-Hour Service Hotline 1-800-551-8633

05/2023

www.frymaster.com

E-mail:
service@frymaster.com



NOTICE

IF, DURING THE WARRANTY PERIOD, THE CUSTOMER USES A PART FOR THIS FRYMASTER DEAN EQUIPMENT OTHER THAN AN UNMODIFIED NEW OR RECYCLED PART PURCHASED DIRECTLY FROM FRYMASTER DEAN, OR ANY OF ITS AUTHORIZED SERVICERS, AND/OR THE PART BEING USED IS MODIFIED FROM ITS ORIGINAL CONFIGURATION, THIS WARRANTY WILL BE VOID. FURTHER, FRYMASTER DEAN AND ITS AFFILIATES WILL NOT BE LIABLE FOR ANY CLAIMS, DAMAGES OR EXPENSES INCURRED BY THE CUSTOMER WHICH ARISE DIRECTLY OR INDIRECTLY, IN WHOLE OR IN PART, DUE TO THE INSTALLATION OF ANY MODIFIED PART AND/OR PART RECEIVED FROM AN UNAUTHORIZED SERVICER.

NOTICE

Drawings and photos used in this manual are intended to illustrate operational, cleaning and technical procedures and may not conform to on-site management operational procedures.

 WARNING

Improper installation, adjustment, alteration, service or maintenance can cause property damage, injury or death. Read the installation, operating and maintenance instructions thoroughly before installing, operating or servicing this equipment.

 DANGER

Hot vegetable oil will cause severe burns. Allow vegetable oil to cool to 100°F (38°C) before transporting to the disposal site. Use extreme caution when transporting and disposing of spent vegetable oil.

 DANGER

Before each use inspect the cover to ensure the cover gasket is present and properly placed. **DO NOT** use the disposal unit if this gasket is damaged or missing.



**Shortening Disposal Unit (SDU)
Installation, Operation, Service, and Parts Manual**

TABLE OF CONTENTS

	Page
1. INTRODUCTION.....	1
1.1 Service Information and Parts Ordering.....	1
1.2 Installation, Operating and Service Personnel.....	1
1.3 Definitions.....	1
1.4 Shipping Damage Claim Procedure.....	2
1.5 What To Do If Your Equipment Arrives Damaged.....	2
2. ASSEMBLY AND OPERATION.....	2
2.1 Equipment Description.....	2
2.2 Equipment Assembly.....	3
2.3 Equipment Operation.....	3
2.4 Cleaning.....	5
3. SERVICE PROCEDURES.....	5
3.1 General.....	5
3.2 Replacing Worn or Damaged O-Rings.....	5
3.3 Replacing Worn Pump Vanes and/or Pump Shaft Seal.....	5
4. PARTS LIST.....	7

SHORTENING DISPOSAL UNIT (SDU 100, 90 50, AND BKSDU) INSTALLATION, OPERATION, SERVICE AND PARTS

1. INTRODUCTION

1.1 Service Information and Parts Ordering

Included with the unit when shipped from the factory is a list of Factory Authorized Servicers (FAS). Refer to this list to find the FAS nearest you. If you do not have access to this list, contact the Frymaster Technical Service Department at 1-800-551-8633 or 1-318-865-1711.

Service information may be obtained by contacting your local FAS. Information may also be obtained by calling the Frymaster Technical Service Department at 1-800-551-8633 or 1-318-865-1711 or by e-mail: service@frymaster.com. In order to assist you as quickly as possible, the FAS or Service Department representative requires certain information about your equipment. The information is printed on a data plate located on the tank cover. When requesting service, please have the following information ready:

Model Number: _____
Serial Number: _____

In addition to the model number, and serial number, please be prepared to describe the nature of the problem and have ready any other information that you think may be helpful in solving your problem. Parts orders may be placed directly with your local FAS or distributor. When ordering parts, the following information is required:

Model Number: _____
Serial Number: _____
Item Part Number: _____
Quantity Needed: _____

RETAIN AND STORE THESE INSTRUCTIONS IN A SAFE PLACE FOR FUTURE USE.

1.2 Installation, Operating and Service Personnel

Installation, Operating, and Service information for this equipment has been prepared for use by qualified and/or authorized personnel only, as defined in Section 1.3.

1.3 Definitions

QUALIFIED AND/OR AUTHORIZED OPERATING PERSONNEL

Qualified/authorized operating personnel are those who have carefully read the information in this manual and have familiarized themselves with the equipment functions, or who have had previous experience with the operation of the equipment covered in this manual.

QUALIFIED SERVICE PERSONNEL

Qualified service personnel are those who are familiar with this equipment and who have been authorized by Frymaster L.L.C. to perform service on equipment manufactured by Frymaster. All authorized service personnel are required to be equipped with a complete set of service and parts

manuals, and to stock a minimum amount of parts for Frymaster equipment. A list of Factory Authorized Service Centers (FAS's) is located on the Frymaster website at www.frymaster.com. *Unless specifically indicated otherwise in this manual, failure to use qualified service personnel will void the Frymaster Warranty on this equipment.*

1.4 Shipping Damage Claim Procedure

This equipment was carefully inspected and packed before leaving the factory. The transportation company assumes full responsibility for safe delivery upon acceptance of the equipment for transport.

1.5 What to Do If Your Equipment Arrives Damaged

1. **File a claim for damages immediately**, regardless of the extent of damages.
2. **Inspect for and record all visible loss or damage** and ensure that this information is noted on the freight bill or express receipt and is signed by the person making the delivery.
3. **Concealed loss or damage** that was unnoticed until the equipment was unpacked should be recorded and reported to the freight company or carrier **immediately** upon discovery. A concealed damage claim must be submitted within 5 days of the date of delivery. Ensure that the shipping container is retained for inspection.

**FRYMASTER DOES NOT ASSUME RESPONSIBILITY
FOR DAMAGE OR LOSS INCURRED IN TRANSIT.**

2. ASSEMBLY AND OPERATION

2.1 Equipment Description

The Shortening Disposal Unit (SDU) is designed for the safe transportation of used shortening or cooking oil from the kitchen to a disposal container. There are three sizes –SDU 50 (50 lbs./23 kg), SDU 90 (90 lbs./41 kg) and SDU 100 (100 lbs./45kg). All sizes are similar in construction and operation. The units consist of a tank and a heavy-duty manual pump. All models are equipped with 6 " (150 mm) wheels.

The BKSDU is equipped with a 120VAC or 240VAC tank heater to prevent solid shortening from solidifying prior to disposal. The BKSDU is equipped with a receptacle that accepts a three-prong, grounded plug for protection against shock hazard. The power cord should be plugged directly into a properly grounded, three-hole wall or floor receptacle. Do not cut off, remove, or otherwise bypass the grounding prong on the power cord plug. **CAUTION: Risk of fire and electric shock. Replace only with manufacturer's cord set, part number 8071224 for 120V or part number 106-4697 for 240V.**

With the cover open, the top of the tank is 9¾ inches (248 mm) above the floor, permitting it to be positioned directly beneath the drains of most fryers.

2.2 Equipment Assembly

Assembly of the unit is a four-step process:

1. Remove the two bolts from the handle-mounting bracket and raise the handle to the upright position. Reinstall the bolts in the bracket and tighten to 8 ft/lbs.
2. Ensure the O-rings and the bottom 2 inches of the suction tube are lubricated with *Accrolube with Teflon* or an equivalent light oil or grease.
3. Turn the pump and suction tube upside down and carefully pour no more than one cup of cooking oil down the tube. Rotate the pump handle slowly three or four times to prime the pump.
4. Insert the suction tube through the pipe bracket on the handle and into the pickup tube on top of the reservoir. Push down on the pump assembly and ensure the suction tube is fully seated.

2.3 Equipment Operation

WARNING

DO NOT use this unit to dispose of water or Boil-out solution. Introduction of water or solvents into the unit will permanently damage the pump.

1. Turn the fryer off prior to draining into SDU. If so equipped, ensure the fryer drainpipe is firmly threaded into the frypot drain valve.
2. Open the cover, verify that the crumb screen and rubber gasket on the inside cover are in place, and position the unit so that the opening is directly under the frypot drainpipe.

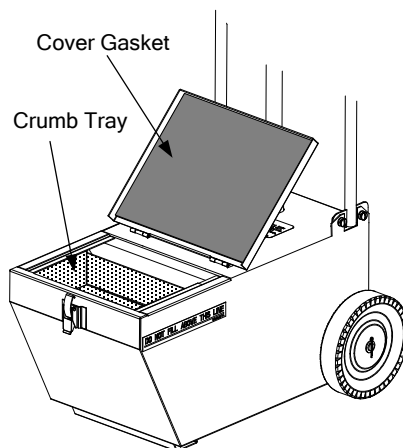

DANGER

Before each use inspect the cover to ensure the cover gasket is present and properly placed. DO NOT use the disposal unit if this gasket is damaged or missing.

3. *Slowly* open the drain valve. Regulate flow with the drain valve to prevent splashing.

⚠ DANGER

DO NOT OVERFILL! Do not fill the reservoir above the fill lines on the sides of the reservoir. Moving the SDU with an overfilled reservoir may result in spills and injury to personnel who come in contact with the spilled shortening.

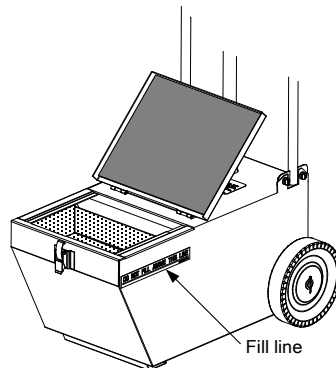

- Carefully withdraw the unit far enough to allow the cover to be closed. Latch the cover in the closed position. Using the handle, carefully tip the unit back slightly for ease of handling and roll the unit to the disposal site.

⚠ WARNING

DO NOT use the pump or discharge piping assembly as a handle!

⚠ DANGER

To minimize the potential for burns, oil must always be allowed to cool below 100°F (38°C) before draining into the SDU and transporting to the disposal area. However, **DO NOT** allow shortening to solidify in the SDU.

The unit is designed to be moved, when properly filled, at an average walking pace on a flat surface. *Care must be taken at all times when moving hot shortening or oil. Rough terrain or sudden stops and starts may cause the contents of the reservoir to spill or splash out of the reservoir, possibly causing serious injury to personnel. Always ensure that the cover is latched shut when moving the unit.*

- At the disposal site, lift the pump assembly lock pin and rotate the discharge pipe as necessary to position the discharge nipple over the opening of the disposal container. Release the lock pin to secure the pump assembly in position. Turn the pump handle clockwise. The pump should start discharging oil after a few turns. Continue turning the handle until the MSDU reservoir is empty.
- On BKSDU units, the built-in heater may be connected to a grounded 120VAC or 240VAC receptacle to prevent shortening from solidifying in the tank when immediate transfer to a disposal container is not possible.

2.4 Cleaning

Clean the crumb screen with a solution of detergent and water. Clean the *exterior surfaces* of the SDU with a soft cloth and a solution of detergent and water. It is not necessary to clean the interior of the reservoir, but if desired it may be wiped down with clean paper towels to remove excess residual shortening.

 **WARNING**

DO NOT clean the interior of the reservoir with water or detergent. Introduction of water or detergent into the unit will permanently damage the pump.

3. SERVICE PROCEDURES

3.1 Introduction

Other than routine cleaning and the replacement of worn suction tube O-rings, the SDU is maintenance free. After long use, the pump vanes and pump shaft seal may require replacement due to wear. Frymaster recommends worn pump vanes and/or pump shaft seals be replaced by an FAS, but store personnel may perform these service actions without voiding the warranty.

3.2 Replacing Worn or Damaged O-Rings

If pump efficiency degrades, it is likely that the O-rings on the suction tube are worn or damaged. To replace the O-rings, follow the steps below.

1. Lift the pump assembly straight up and out of the handle assembly.
2. Remove the worn or damaged O-rings from the grooves at the bottom of the suction tube and replace with new O-rings. Apply *Accrolube with Teflon* grease or equivalent to bottom 2 inches of the suction tube.
3. Insert the suction tube through the tube bracket in the handle and into the receiver on top of the reservoir. Push down on the pump assembly to make sure the suction tube is fully seated.

4. PARTS LIST

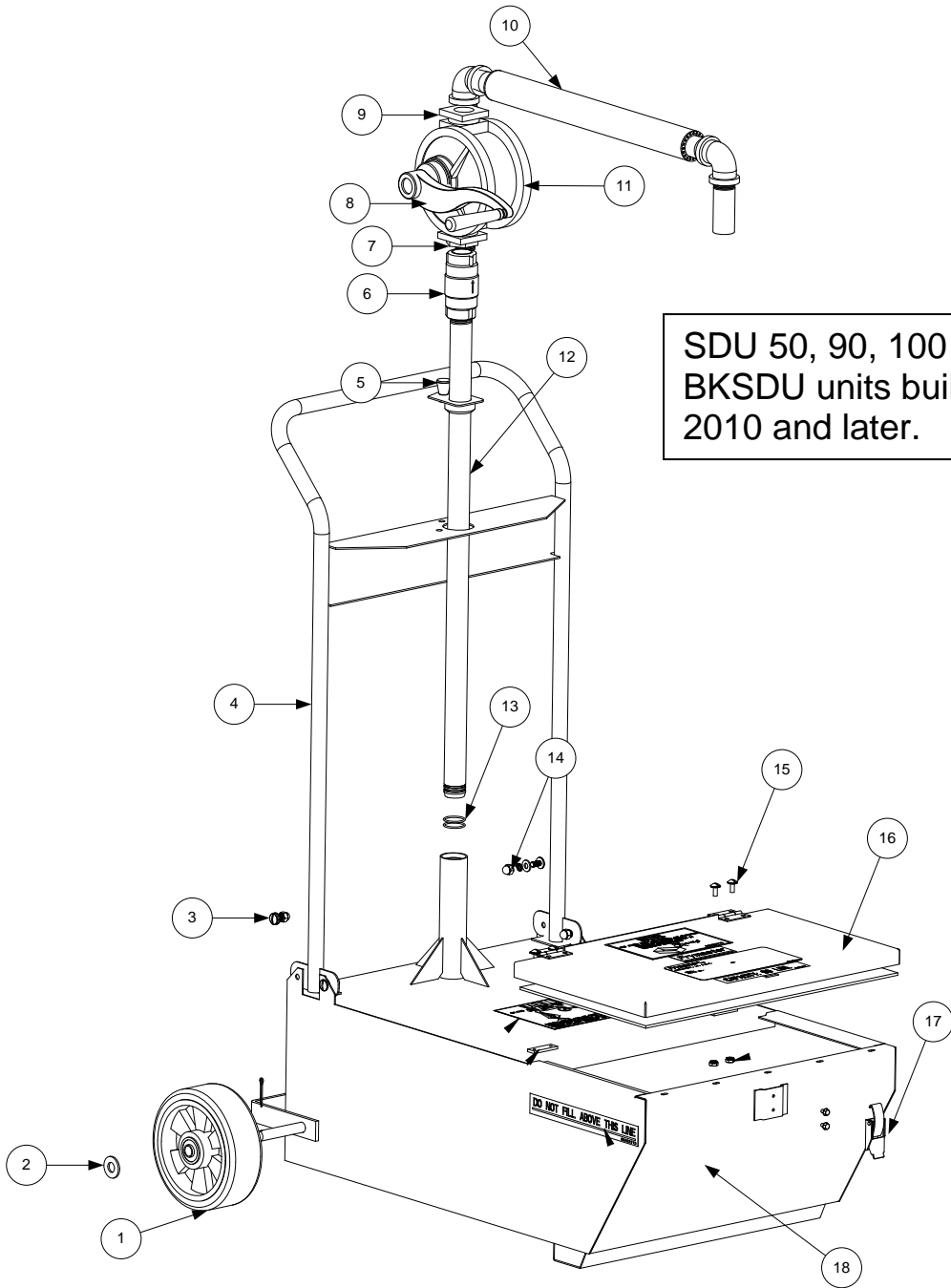

Item	Part #	Component
1	810-3784	Wheel, 6" x 2"
2	809-0200	Washer, flat, 1/2"
3	809-1001	Screw, 1/4 x 20 x 1/2"
4	823-2421	Handle, SDU 90, 100
*	823-2038	Handle, SDU 50, BKSDU
5	810-0777	Spring-loaded plunger
6	810-3858	Check valve, 3/4" NPT (Added August 2010)
7	813-0032	Bushing, hex 1 x 3/4
8	810-0657	Pump handle
9	813-0109	Nipple, 3/4 NPT close
10	823-4600	Discharge pipe, SDU 50, SDU 90
*	823-7935	Discharge pipe, SDU 100
*	823-4617	Discharge pipe, BKSDU
*	108-2580	SDU 100 Complete discharge assembly: pump, discharge pipes, check valve
*	108-2303	SDU 50/90 Complete discharge assembly: pump, discharge pipes, check valve
*	106-3767	BKSDU Complete discharge assembly: pump, discharge pipes
11	810-0784	Pump
12	823-7849	Suction pipe, SDU 50, 90, 100
		See BKSDU Pump Enclosure on page 11
*	823-4581	Suction pipe, BKSDU
13	816-0132	O-ring
14	809-1001	Screw, 1/4x20x1/2
*	809-0047	Cap, nut 1/4x20
*	809-0193	Flat washer, 1/4 nylon
15	809-0119	Screw, 10x32x1/2
16	823-2422	Cover assembly, SDU 90
*	823-7804	Cover assembly, SDU 100
*	823-1683	Cover assembly, SDU 50, BKSDU
*	816-0877	Cover gasket, SDU 100
*	816-0264	Cover gasket, SDU 90
*	816-0134	Cover gasket, SDU 50, BKSDU
*	816-0133	Cover hinge gasket
*	108-2210	Crumb screen, SDU 100
*	108-0706	Crumb screen, SDU 90
*	108-0705	Crumb screen, SDU 50, BKSDU
17	810-0742	Latch
18	823-2420	Tank assembly, SDU 90
*	823-7803	Tank assembly, SDU 100
*	823-4580	Tank assembly, SDU 50
*	823-6268	Tank assembly, BKSDU
*	823-6267	Heater assembly for BKSDU (other BKSDU heater components on page 10,11)

* Not illustrated.

** **CAUTION:** Risk of fire and electric shock. Replace only with manufacturer's cord set, part No. [8071224](#) for 120V.

NOTE: See Page 6 for BKSDU pump assembly components.

**SDU 50, 90, 100
and BKSDU units
built before April
2010.**

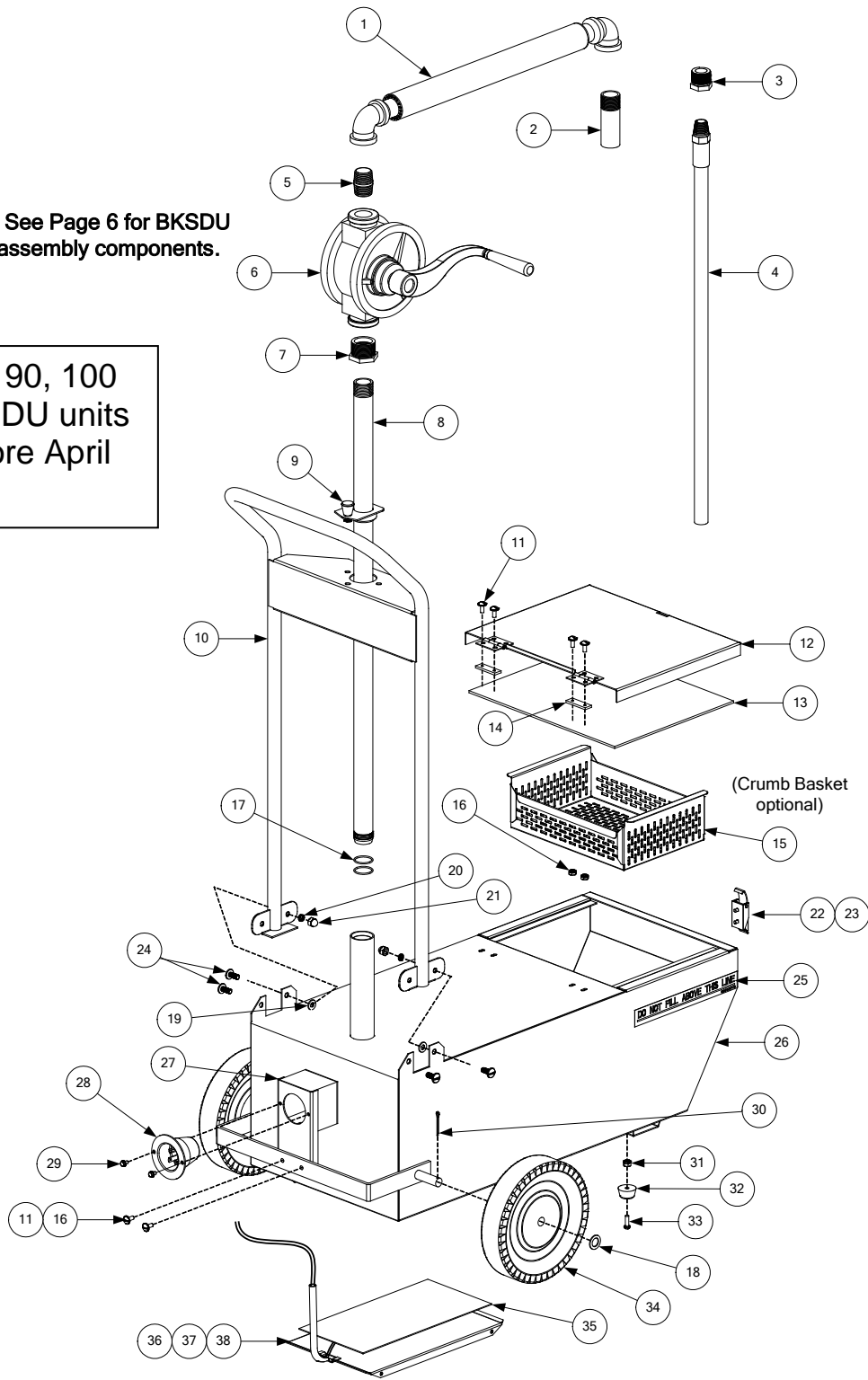

Item	Part #	Component
1		Pipe Assembly, Discharge
	823-4600	Standard (includes Item 2) (use 823-4617 for BKSDU)
	823-4598	For use with Item 4 (Hose Discharge) (includes Item 3)
2	813-0115	Nipple, ¾-inch x 3-inch Toe
3	813-0031	Bushing, ¾-inch x ½-inch
4	810-1845	Hose, 24-inch Discharge (Optional) (use 810-2797 for 48-inch hose)
5	813-0109	Nipple, ¾-inch x Close
6	810-0784	Pump (includes handle 810-0657, which may be ordered separately)
*	826-2774	Check valve kit
*	816-0401	Seal, Pump Shaft
7	813-0032	Bushing 1-inch x ¾-inch Hex
8	823-4581	Pipe Assembly, Suction
9	810-0777	Pin, Plunger
10		Handle Assembly
	823-2038	SDU50 and BKSDU
	823-2421	SDU90
11	809-0119	Screw, 10-32 x ½-inch Slotted Head
12		Cover and Hinge Assembly
	823-1683SP	SDU50 and BKSDU (does not include gasket (Item 13))
	823-2422SP	SDU90 (does not include gasket (Item 13))
13		Gasket, Cover (attach with 3M 1300L adhesive or equivalent)
	816-0134	SDU50 and BKSDU
	816-0264	SDU90
14	816-0133	Gasket, Cover Hinge
15		Crumb Basket (optional)
	824-0438	SDU50 and BKSDU
	824-0615	SDU90
16	826-1376	Nut, 10-32 Keps Hex (Pkg. of 10)
17	816-0132	O-ring, Suction Pipe Assembly (2 required)
18	809-0200	Washer, Wheel ½" SAE
19	809-0193	Washer, ¼-inch Nylon Flat
20	809-0191	Lock Washer, ¼-inch
21	809-0047	Nut, ¼-20 S/S Cap
22	810-0742	Latch, Tank Cover
23	809-0359	Screw, #8 x ¼-inch
24	809-1001	Screw, ¼-20 x ½" Slotted Head
25	802-0227	Label, Fill Line
26		Tank and Axle Assembly
	823-4580SP	SDU50 and BKSDU
	826-2103	SDU50 Retrofit Kit for SDU's manufactured before Jan. 2004.
	823-4583	SDU90 If replacing tank manufactured pre-Jan.2004, 823-4581 will also be needed.
27x	823-1911	Housing, 120VAC Receptacle (BKSDU only) (use 823-5060 for 240VAC)
28x	807-1219	Receptacle, 120V 3-wire (BKSDU only) (use 807-4108 for 240VAC)
29	809-0266	Screw, #10 x ½-inch Phillips Truss Head (use 809-0396 for 240VAC Receptacle)
30	810-0783	Cotter Pin, Wheel
31	809-0054	Nut, 10-32 Elastic Lock (BKSDU only)
32	814-0051	Bumper, Rubber (BKSDU only)
33	809-0122	Screw, 10-32 x ⅝-inch Slotted Round Head (BKSDU only)
34	810-1112	Wheel, 7-inch x 1½-inch
35	807-1577	Heater, 120V 50W 5" x 10" (BKSDU only)
*	807-1224	Cord, Power – 120VAC (BKSDU only)** (use 106-4697 for 240VAC)
36	823-1915	Shield Heater (BKSDU only)
37	809-0104	Screw, 8-32 x ½-inch Slotted Truss Head (BKSDU only)
38	809-0247	Nut, 8-32 Keps Hex (BKSDU only)
*	815-0661	Adhesive, 3M 1300L

* Not illustrated.

** **CAUTION:** Risk of fire and electric shock. Replace only with manufacturer's cord set, part No. [8071224](#) for 120V.

NOTE: The BKSDU pump assembly is identical to the SDU 50/SDU 90 pump assembly except for the addition of the pump cover and insulation and the modified discharge pipe assembly.

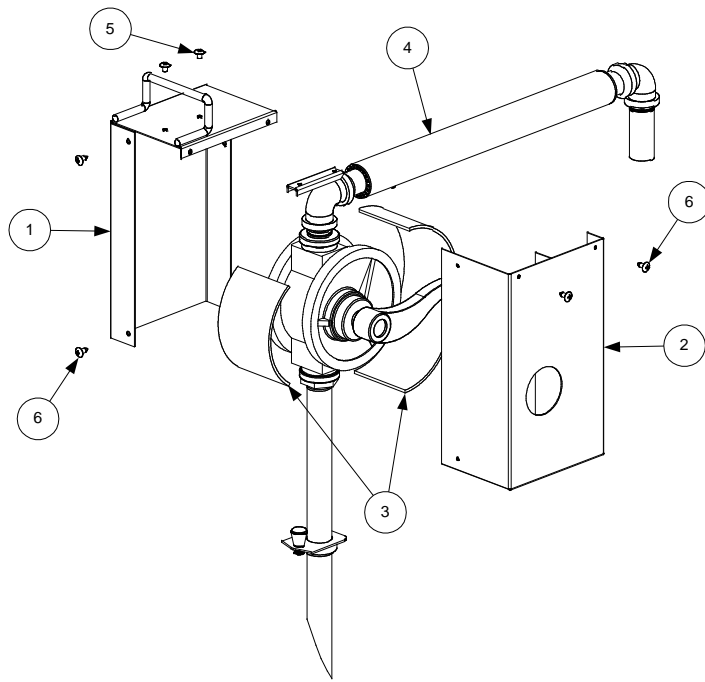

ITEM	PART #	COMPONENT
1	823-1847	Cover and Handle Assembly, BKSDU
2	900-4429	Box, BKSDU Pump
3	811-0861	Insulation, 3-inch X 50-foot Adhesive-Backed Foam
4	823-4617	Pipe Assembly, BKSDU Discharge
5	809-0477	Screw, #10 X 1/4-inch Philips Truss Head
6	809-0266	Screw, #10 X 1/2-inch Philips Truss Head

Frymaster[®]

FRYMASTER
8700 LINE AVENUE, SHREVEPORT, LA 71106-6800

800-551-8633
318-865-1711
WWW.FRYMASTER.COM
EMAIL: FRYSERVICE@WELBILT.COM



Welbilt offers fully-integrated kitchen systems. Welbilt's portfolio of award-winning brands includes Cleveland™, Convotherm®, Crystal Tips®, Dean®, Delfield®, Fabristeel®, Frymaster®, Garland®, Inducs®, Koldtech®, Kolpak®, Lincoln®, McCann's™, Merco®, Merrychef®, Multiplex®, RDI®, SerVend™, SunFire®, U.S. Range™, and WMaxx™. Supported by service brands: FitKitchen®, kitchen systems; and KitchenConnect®, cloud-based open platform.

Bringing innovation to the table • welbilt.com

©2023 Frymaster LLC. except where explicitly stated otherwise. All rights reserved. Continuing product improvement may necessitate change of specifications without notice.

Part Number FRY_IOSP_8195703 05/2023