

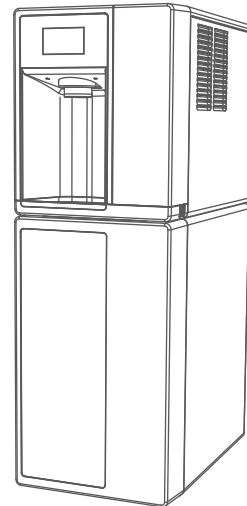

Champion™ 7 and Champion 15 Ice and Water Dispenser with Chewblet® Ice Machine CI112A, UC112A, UD112A

Installation, Operation and Service Manual
115 V

Please visit <https://www.follettice.com/technicaldocuments>
for the Operation and Service manual for your unit.

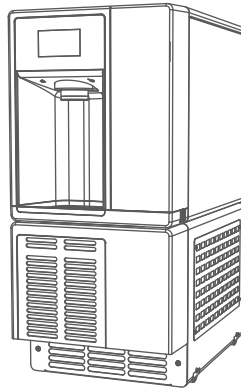
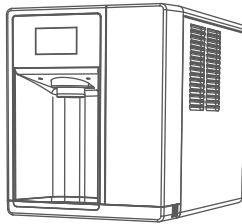

Welcome to Follett

Follett equipment enjoys a well-deserved reputation for excellent performance, long-term reliability and outstanding after-the-sale support. To ensure that this equipment delivers that same degree of service, review this guide carefully before you begin your installation.

Should you need technical help, please call our Technical Service group at (877) 612-5086 or (610) 252-7301.

Please have your model number, serial number and complete and detailed explanation of the problem when contacting Technical Service.

Getting Started

After uncrating and removing all packing material, inspect the equipment for concealed shipping damage. All freight is to be inspected upon delivery. If visible signs of damage exist, please refuse delivery or sign your delivery receipt "damaged." Follett Customer Service must be notified within 48 hours. Wherever possible, please include detailed photos of the damage with the original packaging so that we may start the freight claim process.



CAUTION!

- Do not tilt unit further than 30° off vertical during uncrating or installation.
- Dispenser bin area contains mechanical, moving parts. Keep hands and arms clear of this area at all times. If access to this area is required, power to unit must be disconnected first.
- This appliance is not suitable for installation in an area where a water jet could be used.
- This appliance must not be cleaned by a water jet.
- User maintenance should not be done by children.
- Follett recommends a Follett water filter system be installed in the ice machine inlet water line (standard capacity #00130229, high capacity #00978957, carbonless high capacity #01050442, Claris standard).
- Prior to operation clean the dispenser in accordance with instructions found in this manual.
- Do not block air intake or exhaust.
- This appliance should be permanently connected by a qualified person in accordance with application codes.
- A qualified person shall provide a readily accessible disconnect device incorporated into the fixed wiring.
- If the supply cord is damaged, it must be replaced by the manufacturer, its service agent or similarly qualified persons in order to avoid a hazard.
- This appliance can be used by children aged 8 years and above and persons with reduced physical, sensory, or mental capabilities, or lack of experience and knowledge if they have been given supervision or instruction concerning use of the appliance in a safe way and understand the hazards involved. Children should be supervised to ensure that they do not play with the appliance.
- This appliance is designed for commercial use.
- **WARNING!** To avoid a hazard due to instability of the appliance, it must be fixed in accordance with the instructions.
- Warranty does not cover exterior or outside installations.
- To reduce risk of shock, disconnect power before servicing.
- Connect to potable water supply only.
- Ice is slippery. Maintain counters and floors around dispenser in a clean and ice-free condition.
- Ice is food. Follow recommended cleaning instructions to maintain cleanliness of delivered ice.

Before You Begin

The serial number of your unit is located on the chassis directly behind the front drip tray. The drip tray can be easily removed by pulling it straight forward. The serial number can also be found on top of the condenser.

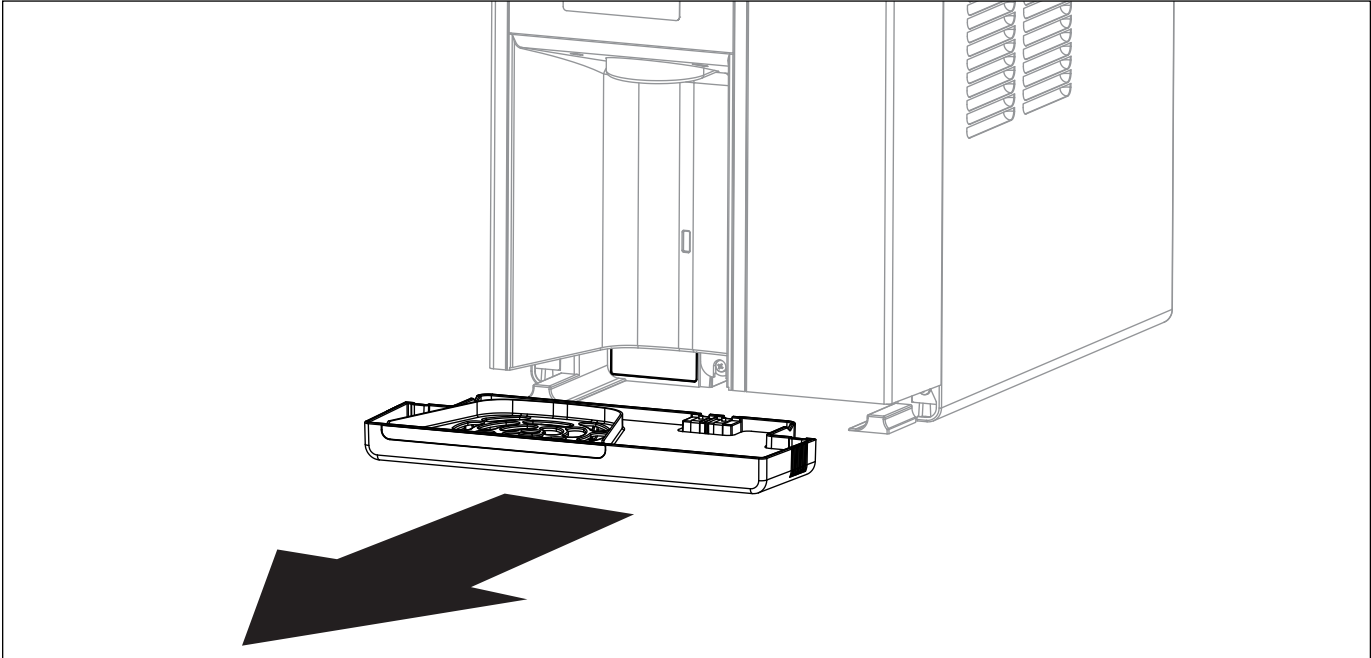

Specifications

Dimensions

	Width	Depth	Height	Unit Shipping Weight
7CI112A	14.56" (37 cm)	22.38" (56.8 cm)	17.59" (44.7 cm)	92 lbs (41.7 kg)
15CI112A	14.56" (37 cm)	22.38" (56.8 cm)	22.47" (57.1 cm)	105 lbs (47.6 kg)
7UC112A	14.56" (37 cm)	22.38" (56.8 cm)	33.50" (85.1 cm)	120 lbs (54.4 kg)
7UD112A	14.56" (37 cm)	22.38" (56.8 cm)	31.50" (80 cm)	120 lbs (54.4 kg)

Note: Base stand ships separate

Ambient Information



CAUTION!

The Champion dispensers are for indoor use only. Designed for commercial use. Follett is not able to provide in-house services for residential installations.

	Maximum*	Minimum*
Air Temperature†	100 F (38 C)	50 F (10 C)
Water Temperature	90 F (32.2 C)	40 F (4.5 C)
Water Pressure	70 psi (483 kpa)	10 psi (69 kpa)
Relative Humidity	55% at 78 F (25.5 C)	

* Use outside of these limitations is misuse and will void warranty. Maintain proper clearances and ventilations; ensure vents are not blocked or compromised resulting in above specification temperatures and condenser failure.
† Best performance is achieved between 80 F (27 C) and 50 F (10 C).

Plumbing

- Water Inlet: 1/4" OD tube, John Guest push-in fitting
- Water shut-off recommended within 5 ft (1.5 m) of dispenser

Options

- Water Dispense (P/N 01535889)
- Internal Claris Filter (P/N 01535327)
- External Claris filter (P/N 01536127)
- 4" legs countertop model (P/N [00956300](#))
- 6" legs freestanding models (P/N [00956318](#))
- Base stand for countertop models (P/N 01453661)
- Drip tray drain with 4" legs 7/15CI (P/N 01535343)
- Drip tray drain for Freestanding Models (P/N 01535335))

Water

WARNING!

Connect to potable water supply only.

- Maximum total dissolved solids (TDS) 400 ppm. Ion exchange filtration or RO can reduce hardness.
- Minimum TDS 10 ppm.
- Maximum silica 20 mg/L. Reverse osmosis (RO) must be used to remove silica.
- Maximum water hardness 100 ppm as CaCO₃ (6 grains per gallon). Ion exchange filtration or RO can reduce hardness.
- Not recommended for use with sodium softened water
- Ingress Protection (IP) rating: IPX0 (no protection)
- Use provided water hardness test strips to verify incoming water hardness and adjust bypass setting on Claris filter head (preinstalled behind front cover on most models). Refer to the below table for appropriate settings. Adjust the bypass setting after completing the *Internal Claris Filter Flushing Sequence* section.

Hardness (ppm)	Setting	Interval (month)	Gallons
0	6	12	1000
50	5	9	800
120	3	6	500
250	2	4	200
425	0	2	100

Note: Claris filter manifold is factory set at 3 prior to shipment.

Clearances

- CI Models: 3" (7.62 cm) on each side of dispenser, 2" (5.08 cm) behind for electrical/water connection/ventilation
- UD/UC Models: 2" (5.08 cm) behind dispenser for electrical and optional drain connection. 6" (15.3 cm) in front of dispenser for ventilation.

Electrical

115 V

- 115 V, 60 Hz, 1 phase, 4A (hot water option: 8A), maximum fuse or breaker 15A
- Connect to dedicated 15A circuit, fuse or breaker
- Must be grounded - requires 3-prong outlet. Do not remove ground.
- NEMA 5-15P 90 degree, 8' (2.4 m) cord supplied with machine

Refrigeration

WARNING!

Do not damage the refrigerant circuit. Refrigerant can cause personal injury and/or damage dispenser.

- Refrigerant
 - 115 V: R513a – 6.2 ounces (176 grams)

Heat Rejection

- 1700 BTU/hr (498 W)

Champion 7 Detailed Drawing - CI Models (with freestanding base)

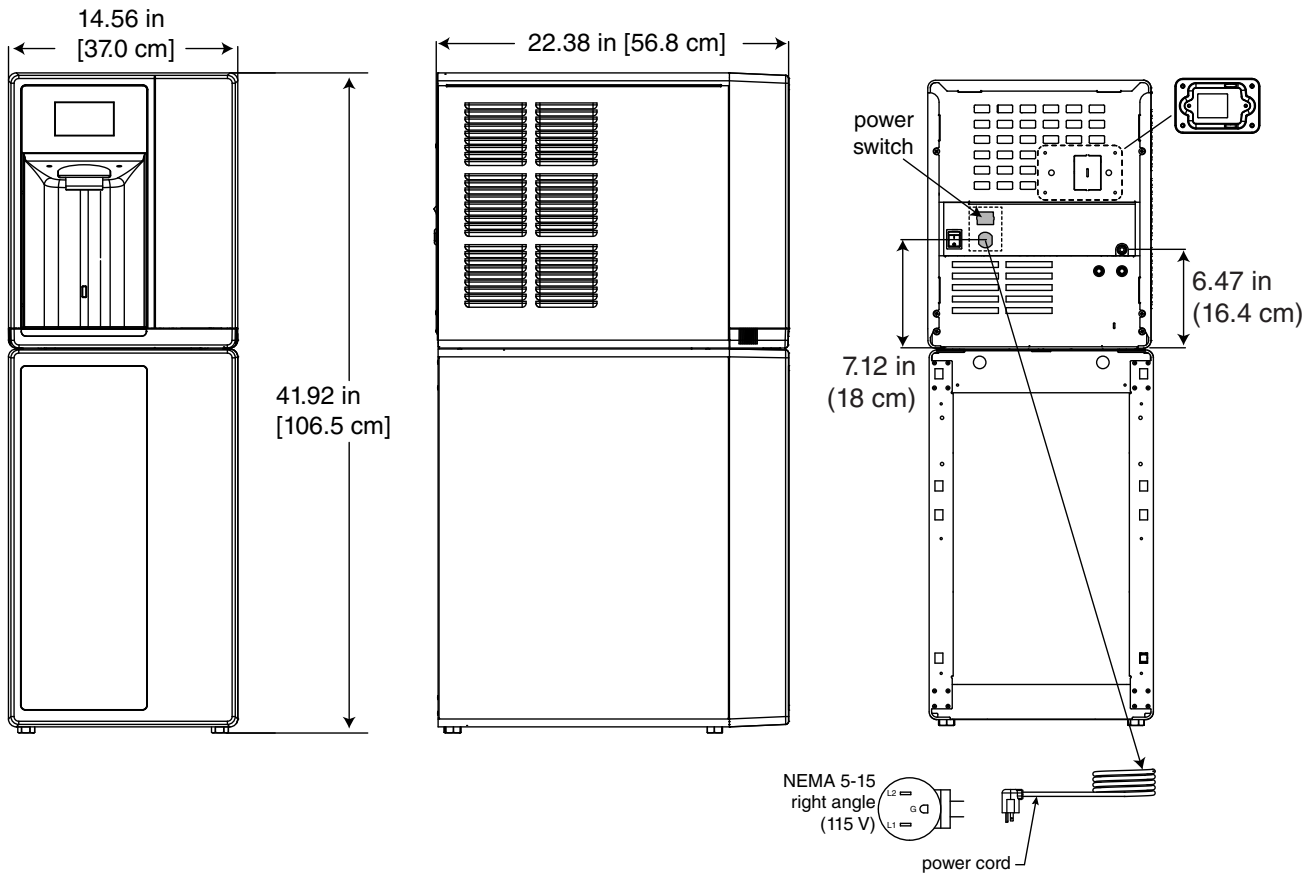

Champion 15 Detailed Drawing - CI Models (with freestanding base)

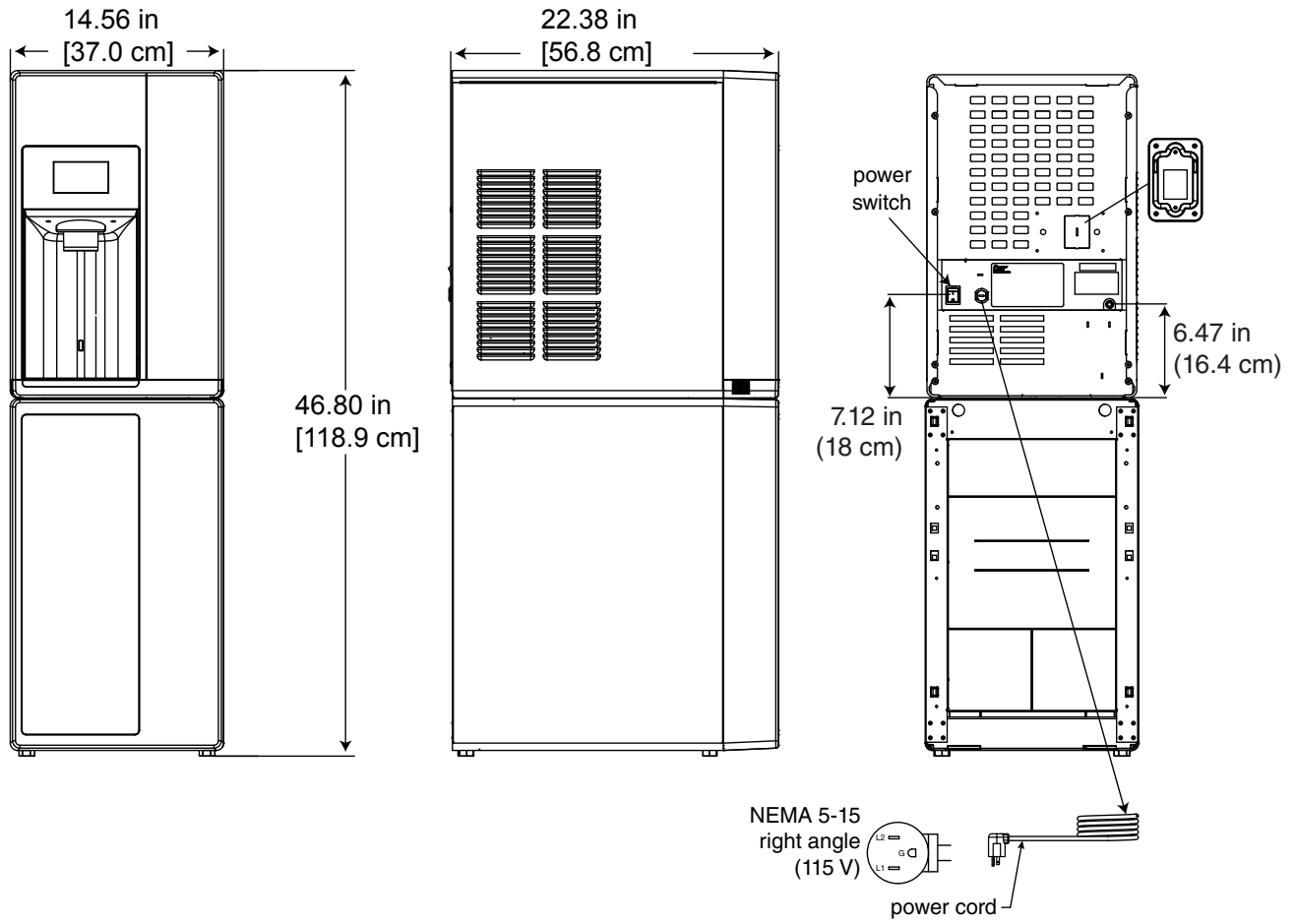

Champion 7 Detailed Drawing - UC and UD Models

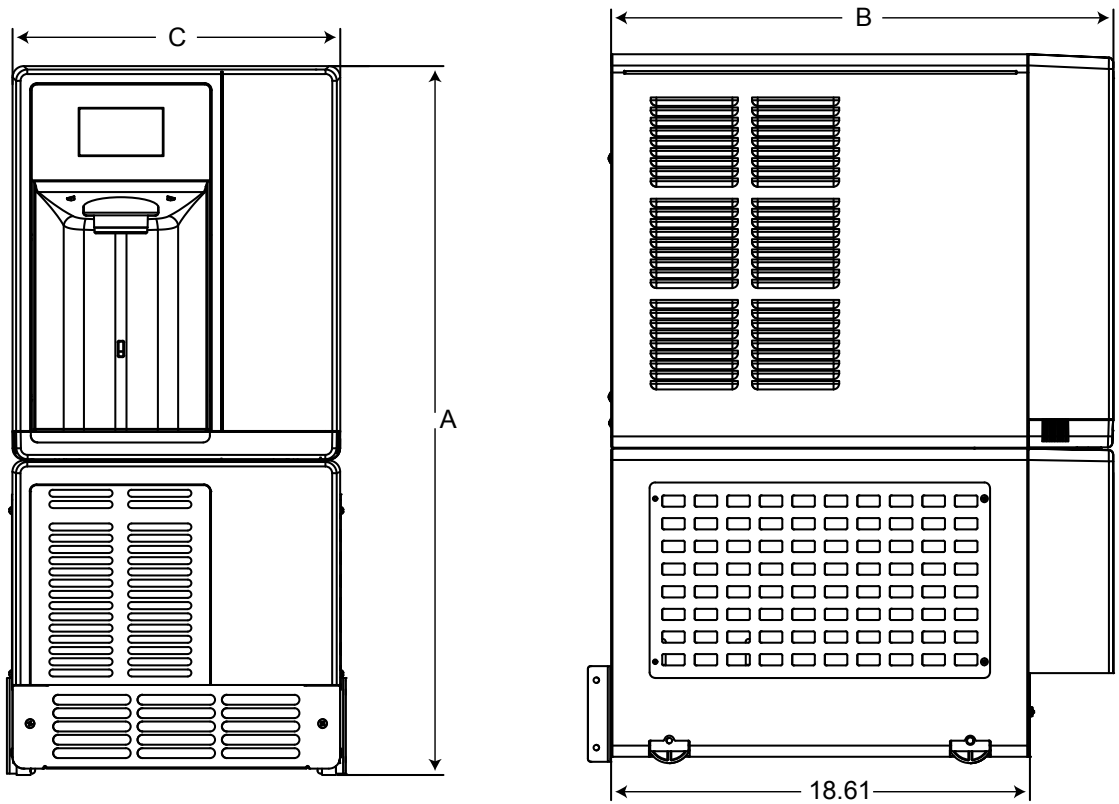

Dimension	7UC112A	7UD112A (ADA)
A	33.50" (85.1 cm)	31.50" (80 cm)
B	22.38" (56.7 cm)	22.38" (56.7 cm)
C	14.56" (37 cm)	14.56" (37 cm)

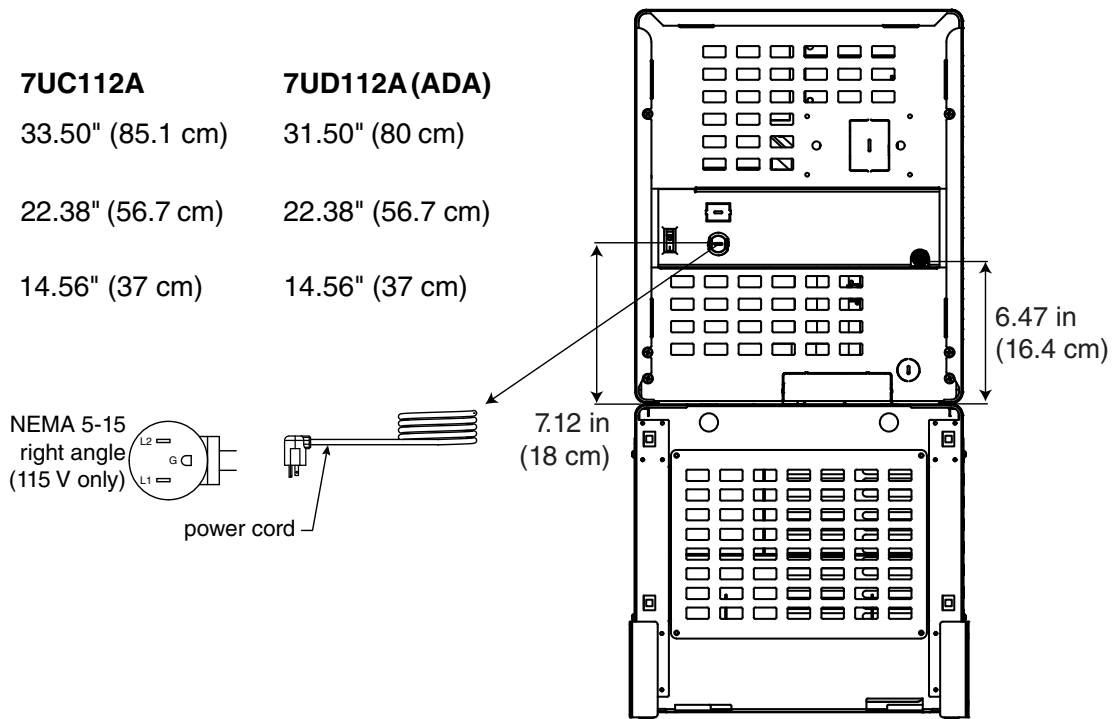

Installation

CAUTION!

No service or maintenance should be performed until the technician has thoroughly read this service manual. Except for routine cleaning and sanitizing, only qualified technicians should attempt to service or maintain this equipment.

Countertop Installation

The Champion 7 countertop model is designed to fit on counters underneath standard mounted cabinets, this does not apply to Champion 15 models.

1. 3" (7.62 cm) on each side of dispenser, 2" (5.08 cm) behind for electrical/water connection/ventilation (**Fig. 1**).
2. Rough-in the electrical service and water line.
 - Water: supply line (with shut-off valve) connects to the dispenser's 1/4" OD tube quick connect.

NOTICE!

If installing optional Drip Tray Drain Kit or Leg Accessory, complete those steps before proceeding.

CAUTION!

Use caution when tipping the dispenser during leg installation. Do not lay unit on back or side. DO NOT EXCEED 30° angle. Tipping more than 30° can result in compressor malfunction.

3. If installing optional 4" Leg Accessory (item# 00956300), place a 5" (12.7 cm) spacer underneath the dispenser to ease installation.
4. Remove four plastic, thread-protecting plugs from bottom of dispenser.
5. Screw each leg into chassis (**Fig. 2**).
6. Complete *Potable Water Connection* before proceeding.

Fig. 1

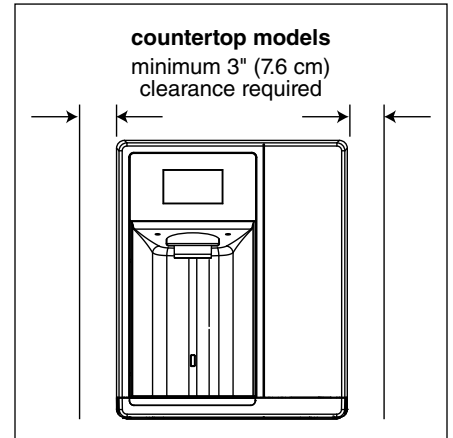
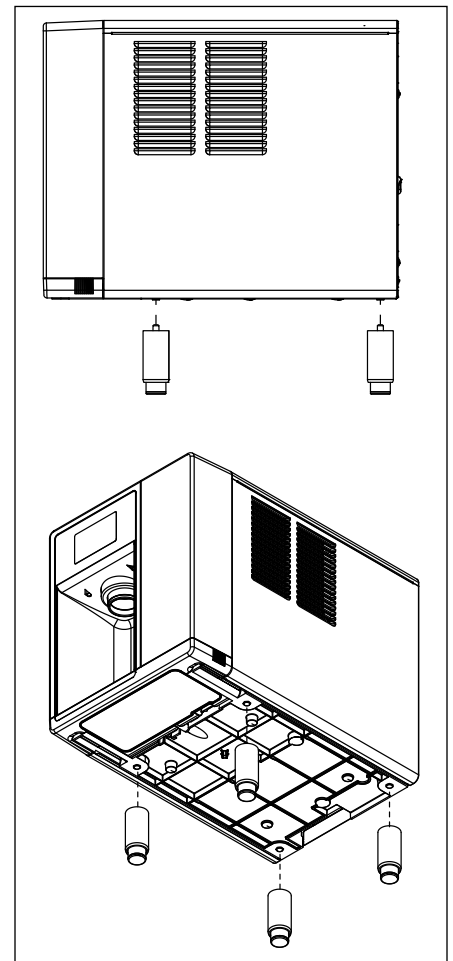

Fig. 2



Freestanding Installation

1. 3" (7.62 cm) on each side of dispenser, 2" (5.08 cm) behind for electrical/water connection/ventilation (**Fig. 3**).
2. Rough-in the electrical service and water line.
 - Electrical: 115 V, single phase, 15A dedicated receptacle required. The dispenser has an integral 8 ft (2.4 m) cord and plug.
 - Water: supply line (with shut-off valve) connects to the dispenser's 1/4" OD tube quick connect.

Fig. 3

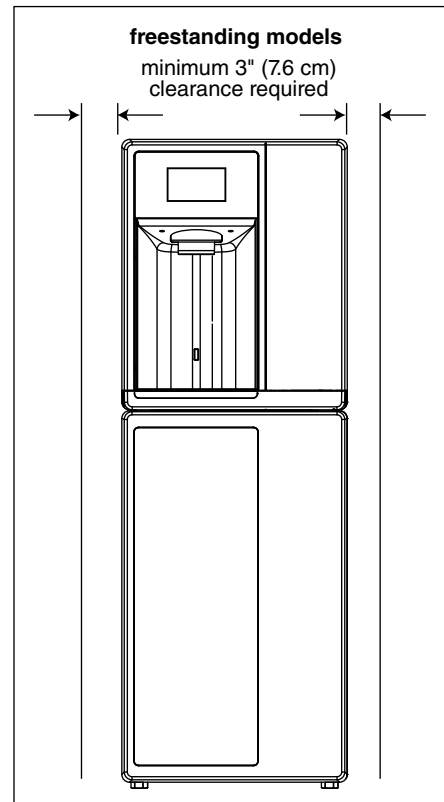

3. If installing optional 6" Leg Accessory (item# [00956318](#)), tilt or lay base stand on side and screw each leg into stand (**Fig. 4**).

Fig. 4

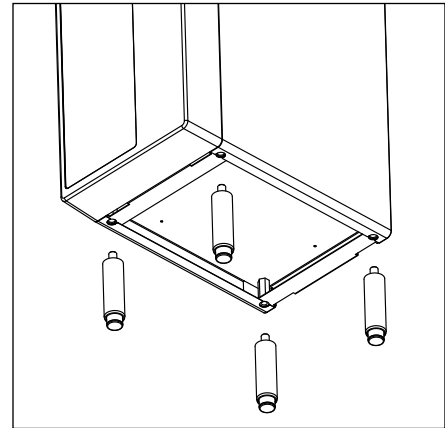

4. Remove four plastic, thread-protecting plugs from bottom of dispenser.
5. Attach dispenser to base stand with supplied hardware (**Fig. 5**).

NOTICE!

If installing optional Drip Tray Drain Kit, refer to instructions included with the Drip Tray Drain Kit.

Fig. 5

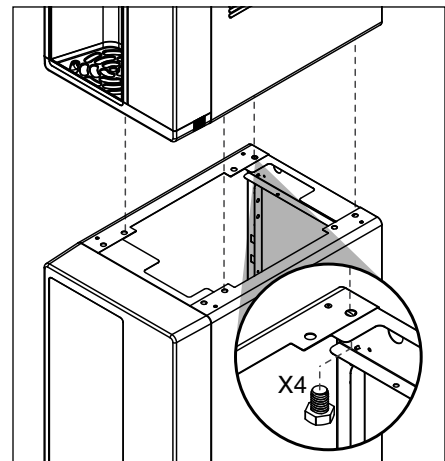

6. Complete *Potable Water Connection* before proceeding.
7. Secure unit to wall or cove molding with supplied bracket (**Fig. 6**) to prevent tipping.

Note: Fasteners must be supplied by installer.



WARNING!

Freestanding unit must be secured to wall to prevent tipping. Failure to do could result in personal injury or damage to the unit.

Undercounter Installation

1. Measure to verify that the dispenser will fit in the desired location. A clearance of at least 2" (5.08 cm) is required behind the dispenser for the electrical and optional drain connection.
2. Ensure that the finished floor inside the cabinet is flush (level) with the floor outside the cabinet (**Fig. 7**). If the cabinet floor is lower than the finished floor, the cabinet floor must be built up (using appropriate materials) until it is flush with the finished floor. A flush floor is required for proper operation and maintenance/service of the dispenser.
3. Rough-in the electrical service and water line.*.

Note: The dispenser must be installed such that it can be moved forward at least 4" (10.16 cm) to allow access to the Bin Lid Cleaning Spout (**Fig. 9.6**) for dispenser cleaning and sanitizing. Take this requirement into consideration during rough-in.

- Water: supply line (with shut-off valve) connects to the dispenser's 1/4" OD tube quick connect.

Fig. 6

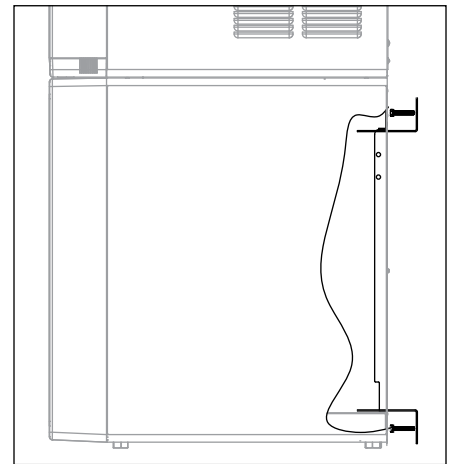
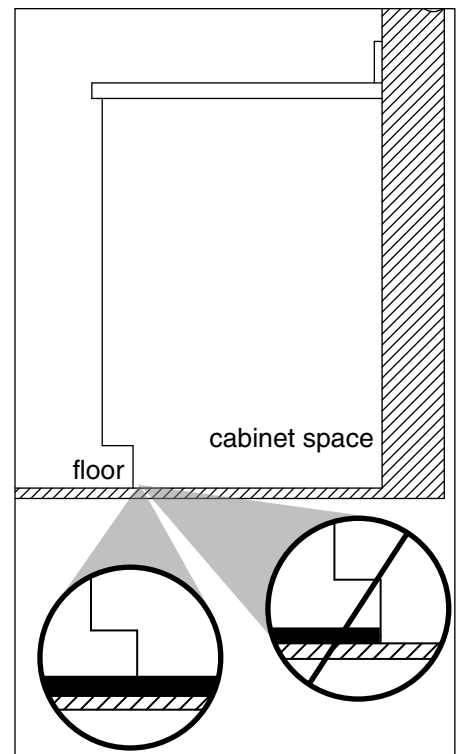
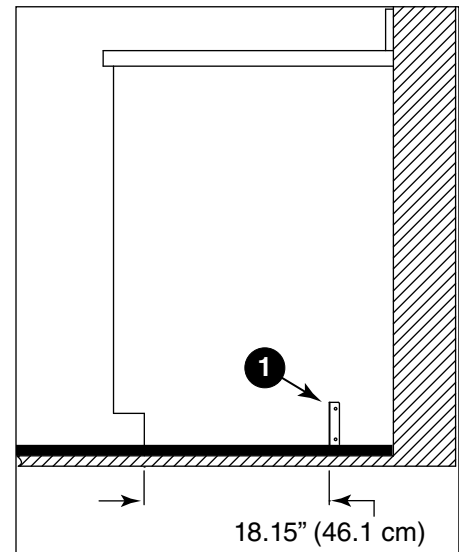

Fig. 7



4. Install the angle bracket inside the cabinet, 18.15" (46.1 cm) from the toe kick (**Fig. 8.1**). The bracket prevents the dispenser from being located/pushed beyond the recommended cabinet space depth. **Do not attach the bracket to the dispenser.**

Fig. 8



Potable Water Connection

1. **Do not supply power to the unit until after the Initial Sanitizing Procedure has been completed.** This ensures that the evaporator is warm and does not contain ice.
2. Connect water line. Recommended routing (**Fig. 9**) allows easy access to water for cleaning and sanitizing procedure.
3. Sanitize the dispenser prior to use (locate the Initial Sanitizing Kit shipped with this unit and complete the **Initial Sanitizing Procedure** section).
4. If the dispenser has the optional internal water filter*, ensure that you also complete the **Internal Claris Filter Flushing Sequence** section before putting the unit into service.

* If your dispenser has the internal water filter option, the water filter *must* be installed for the dispenser to operate.

Fig. 9

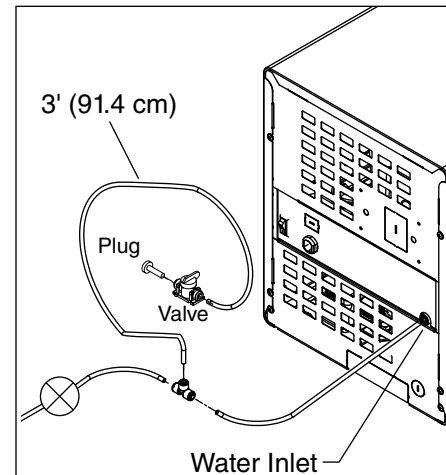

Access Internal Components

CAUTION!

Except for routine cleaning and sanitizing, only qualified technicians should attempt to service or maintain this equipment.

1. Remove the drip tray by pulling straight forward (**Fig. 10.1**).
2. Unscrew the chute (**Fig. 10.2**).
3. Remove the one screw securing the front cover (**Fig. 10.3**).
4. Remove the front cover and set aside. Follett recommends setting the cover on the drip tray, which provides a stable base. Be careful not to stretch or damage any cables connecting the front cover to the unit (**Fig. 10.4**).
5. Remove top sheet metal cover (**Fig. 10.5**).

Fig. 10

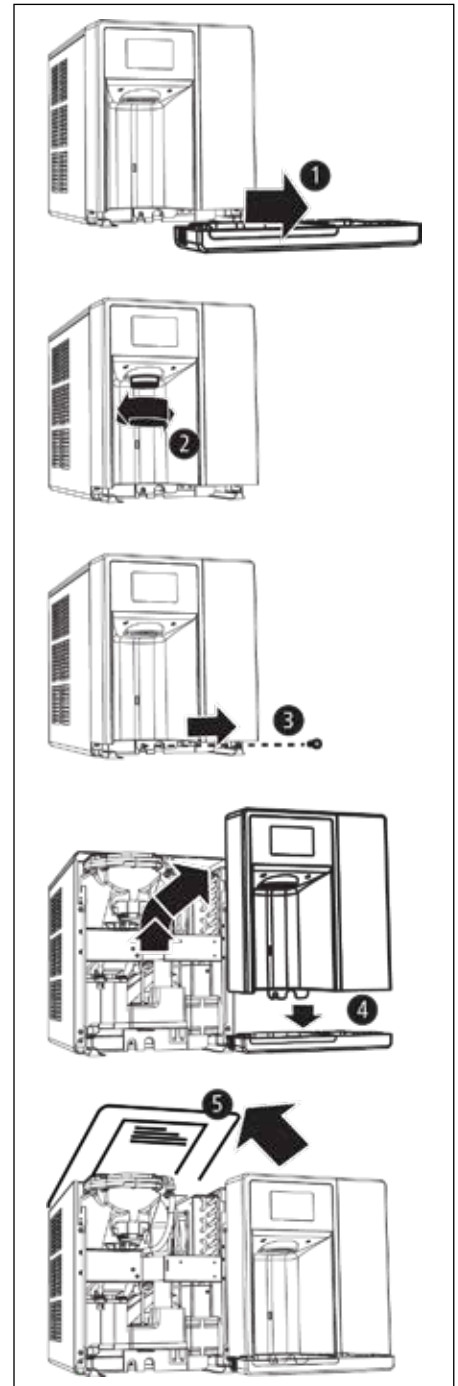

Initial Sanitizing Procedure (unit is not powered)

1. Complete the steps in the *Access Internal Components* section.
2. Remove cap from bin lid cover.
3. Screw bin lid cover cap onto ice discharge chute.
Note: On rear drain units, ensure that the pinch clamp is closed on the ice storage bin rear drain tube. On hot tank units, ensure that the pinch clamp is closed.
4. Champion 7: mix 2.5 gal. (9.5 L) of water and 1 packet Kay-5 sanitizer.
Champion 15: mix 5 gal. (18.9 L) of water and 2 packets Kay-5 sanitizer.
5. Pour sanitizing solution into bin lid access spout until solution reaches the spout neck.
6. Allow the solution to remain in unit for 5 minutes.
7. Drain system by opening pinch clamp and/or lowering drain tube.
8. Secure drain tube into holder.
9. Fill and drain twice with potable water. Secure drain tube.
10. Place a bucket under the dispense chute and remove cap. **Note:** Some sanitizing solution will remain and drain out when cap is removed. Reposition cap on bin lid spout.
Note: On rear drain units, open the pinch clamp on the ice storage bin rear drain tube. On hot tank units, open the pinch clamp.

Set Bypass Level on Internal Claris Filter Head

1. Use the provided water hardness test strips to determine and record the incoming water hardness.

Refer to the below table for appropriate bypass settings. The default bypass setting is 3

Hardness (ppm)	Bypass Setting	Filter Replacement Schedule (month)	Gallons
0	6	12	1000
50	5	9	800
120	3	6	500
250	2	4	200
425	0	2	100

2. If the bypass setting needs to be adjusted, use the following procedure. If the bypass setting does NOT need to be adjusted, proceed to flush the Claris filter.
3. Remove power from the unit.
4. Place a towel or pitcher under the Claris filter.
5. Ensure power is removed and/or unit is off.
6. Remove filter by turning counterclockwise and set aside filter.
Note: Place a towel or pitcher under filter to catch a small amount of water.
7. Remove the two bracket screws so that the underside of the filter head can be accessed.
8. To adjust the bypass level, insert the bypass setting key into the underside of the filter head, press key into filter head, and turn the bypass blending disc to the appropriate setting.
9. After positioning the bypass blending disc, remove and keep the bypass setting key.
10. Reinstall the bracket using the bracket screws.
11. Reinstall the Claris filter.

Internal Claris Filter Flushing Sequence

If your dispenser has the internal Claris filter option, the water filter *must* be flushed prior to use.

To flush the Claris filter, please complete the steps below.

1. Connect power supply and turn on power switch located on back of unit.
2. Place Flushing Hose in 1 gallon (or larger) bucket/container.
3. Rotate flushing valve $\frac{1}{4}$ turn clockwise so "OPEN" is pointing to the Flush Hose (**Fig. 16**).
4. Dispense approximately 1.5 gallons of water into a bucket. (If needed, rotate the flushing valve back to the "CLOSED" position to stop flushing, empty the bucket, then continue flushing until 1.5 gallons has been collected and discarded).

Fig. 11

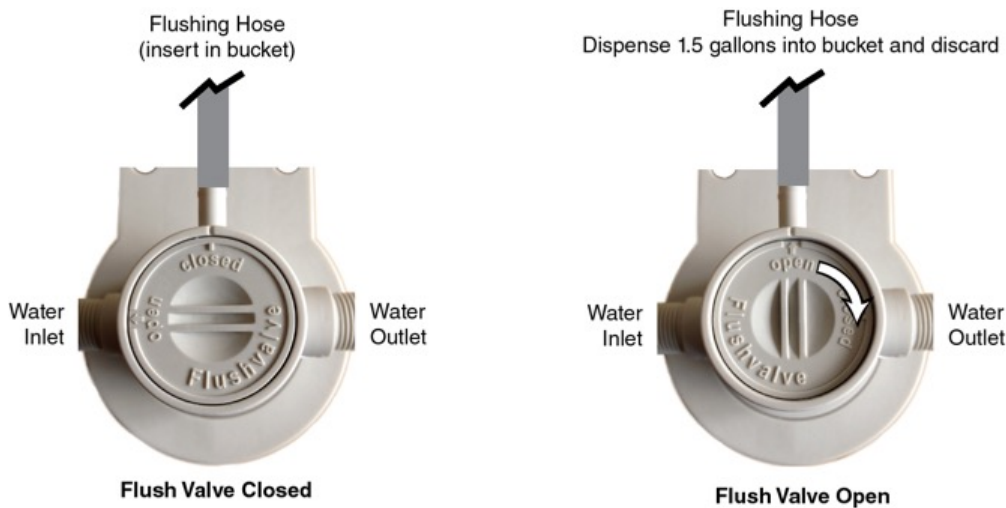

5. Rotate the flushing valve to "CLOSED" (with "OPEN" pointed to exit port of manifold).
6. Remove plug cap from the end of water reservoir drain tube and lower tube to drain water into bucket. After the system has been drained of water, replace plug cap in water reservoir drain tube.
7. Secure tube in holder.
8. Discard water collected in bucket.
9. Reassemble the unit.

User Interface Menu Access

The user interface has several menus that can be accessed for setting up and servicing the Champion dispenser.

1. To access the user interface menus, touch the Follett logo (Fig. 12.1), then touch  (Fig. 12.2), then touch the Follett logo again (Fig. 18.3).

Fig. 12



Select Language

The user interface can be set to display English, Spanish, or French.

1. To select a language (default is English), Choose *Operation Settings*, then *Language*.
2. Select your language from the dropdown menu.

Fig. 13

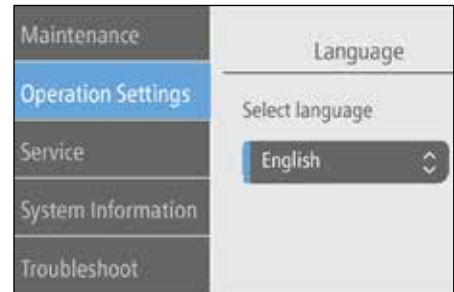

Hot Water Temperature and Display Setting

The default hot water temperature value is 120 and displayed in °F. To change the temperature or to display in °C, follow the steps below.

1. Access the UI menus, then choose *Operation Settings*, then *Hot Water*.
2. Select F or C from the dropdown menu.
3. Adjust the temperature setting using the arrows.

Fig. 14

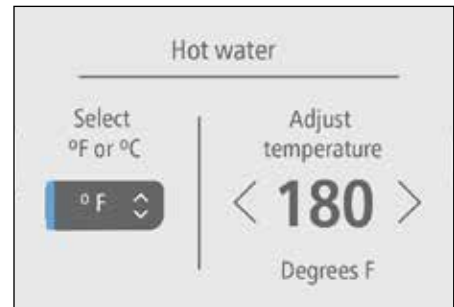

Filter Replacement Reminder

The filter replacement reminder can be set from 0 (off) to 12 months (default). Follett recommends setting the interval based on the results from the *Set Bypass Level on Internal Claris Filter Head* section.

1. Access the UI menus, then choose *Service*, then *Filter Interval*.
2. Adjust the interval setting using the arrows.

Fig. 15

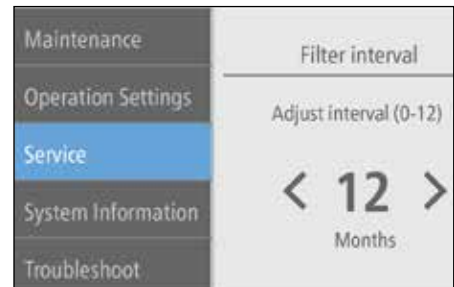

PM (Preventive Maintenance) Reminder – Clean and Sanitize

The PM reminder can be set from 0 (off) to 12 months. The PM reminder default is 6 months.

1. Access the UI menus, then choose *Service*, then *PM Interval*.
2. Adjust the interval setting using the arrows.

Fig. 16

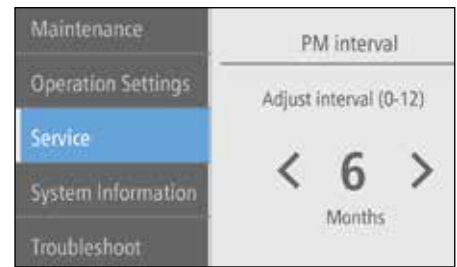

Clean and Sanitize the Unit

Clean and Sanitize Mode (All Operations Disabled) - Use when cleaning ice machine

Entering Clean and Sanitize Mode disables all operations and allows you to safely clean and/or sanitize the ice machine and dispenser.

1. To enter Clean and Sanitize Mode, touch the Follett logo (Fig. 17.1), then touch  (Fig. 17.2), then touch the Follett logo again (Fig. 23.3).

Fig. 17



2. Choose *Maintenance*, then *Clean and Sanitize* (Fig. 18).

Fig. 18

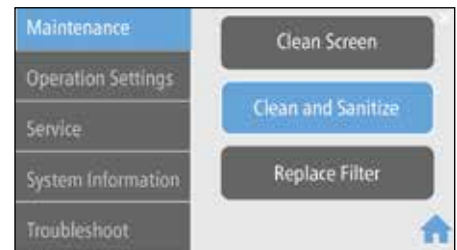

3. Dispense all ice out of the unit (Fig. 19).

Fig. 19

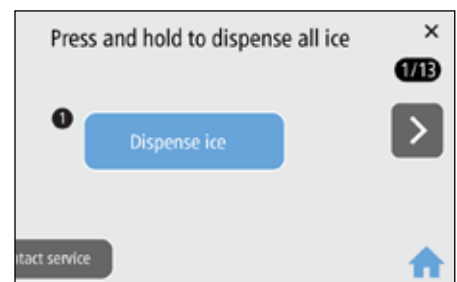

4. Remove the drip tray by pulling straight forward (Fig. 20).

Fig. 20



5. Unscrew the chute (**Fig. 21**).

Fig. 21

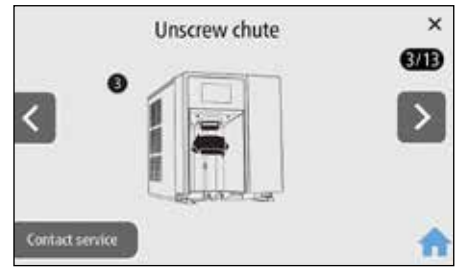

6. Remove the one screw securing the front cover (**Fig. 22**).

Fig. 22



7. Remove the front cover and set aside. Follett recommends setting the cover on the drip tray, which provides a stable base (**Fig. 23**). Be careful not to stretch or damage any cables connecting the front cover to the unit.

Fig. 23



8. Remove plug cap from end of drain tube and lower tube to drain water into bucket (**Fig. 24**). After the system has been drained of water, replace plug cap in drain tube and secure tube in holder.

Fig. 24

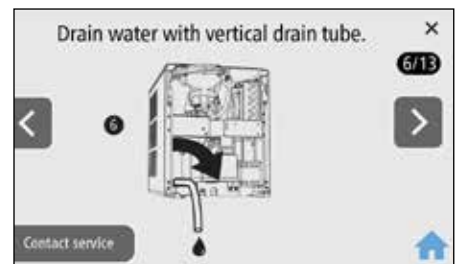

9. Rear drain units: Locate the storage bin drain tube pinch clamp and engage (close) (**Fig. 25**).

Fig. 25

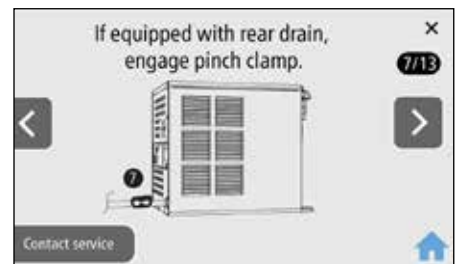

- Hot water tank units: Locate the pinch clamp and engage (close) (Fig. 26).

Fig. 26

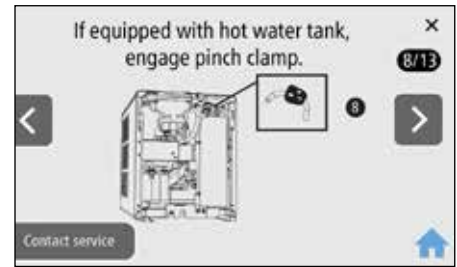

- Remove top sheet metal cover and remove cap from bin lid cover. Screw cap onto dispense chute (Fig. 27).

Fig. 27



- Fill ice bin with hot water (100F - 120F) to melt ice in evaporator. Wait 5 minutes and drain water.
- If equipped with rear drain, disengage pinch clamp, drain water and re-engage clamp.
- The cleaning and sanitizing instructions can be found on the label attached to the underside of the lid (Fig. 29).
- Follow the Cleaning and Sanitizing Procedure on the next page.

Fig. 28

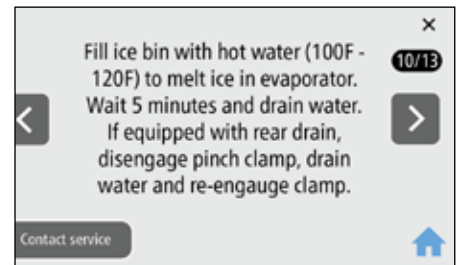

Fig. 29



16. Press and hold to fill with water. Alternately, fill manually through ice bin lid. Drain and repeat a second time (**Fig. 30**).

17. When the Cleaning and Sanitizing procedure is finished, replace cap, lid, right side panel, cover, chute and drip tray.

18. Press Complete (**Fig. 31**).

Fig. 30

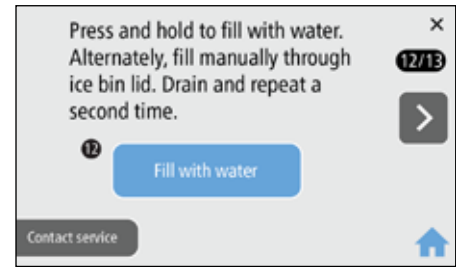
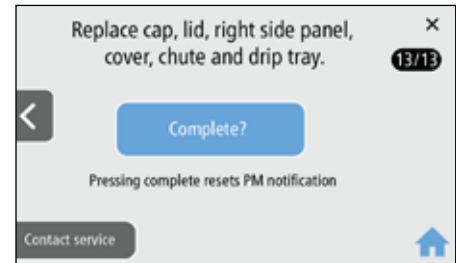

Fig. 31



Cleaning and Sanitizing Procedure

Cleaning and sanitizing should be performed during initial installation and at least every 6 months (more often if local water conditions dictate).

WARNING!

- Place the dispenser in Clean and Sanitize Mode prior to servicing or cleaning the ice machine.
- For protection, rubber gloves and safety goggles (and/or face shield) should be worn when handling SafeCLEAN Plus™.
- Do not use bleach, it will damage the dispenser.

Required Supplies

- Champion 7: 24 oz. (0.71 L) SafeCLEAN Plus™ liquid
- Champion 15: 48 oz. (1.42 L) SafeCLEAN Plus™ liquid
- Funnel
- Bucket
- Multi-head screwdriver
- Towels

Ice Machine and Dispenser

If no power to the unit, please follow the user interface (UI) steps below or refer to the Champion service manual at follettice.com.

1. Touch  located on the upper right corner of the user interface. Scroll down and select Cleaning and Sanitizing from the menu.
2. Begin the cleaning and sanitizing procedure using the user interface:
 - (UI 1) Dispense all ice out of the unit.
 - (UI 2) Remove the drip tray by pulling straight forward.
 - (UI 3) Unscrew the chute.
 - (UI 4) Remove the one screw securing the front cover.
 - (UI 5) Remove the front cover and set aside. Follett recommends setting the cover on the drip tray, which provides a stable base. Be careful not to stretch or damage any cables connecting the front cover to the unit.
 - (UI 6) Remove plug cap from end of drain tube and lower tube to drain water into bucket. After the system has been drained of water, replace plug cap in drain tube and secure tube in holder.
 - (UI 7) Rear drain units: Locate the storage bin drain tube pinch clamp and engage (close).
 - (UI 8) Hot water tank units: Locate the pinch clamp and engage (close).
 - (UI 9) Remove top sheet metal cover and remove cap from bin lid cover. Screw cap onto dispense chute.
 - (UI 10) Fill ice bin with hot water (100 F – 120 F) to melt ice in evaporator. Wait 5 minutes and drain water. If equipped with rear drain, disengage pinch clamp, drain water and re-engage clamp.
 - (UI 11) Locate lid. Follow instructions below.
3. Champion 7: Mix 24 oz. (0.71 L) SafeCLEAN Plus liquid with three gallons (11.4 L) of hot (100 F – 120 F) water.
Champion 15: Mix 48 oz. (1.42 L) SafeCLEAN Plus liquid with six gallons (22.7 L) of hot (100 F – 120 F) water.
4. Pour SafeCLEAN Plus solution into bin lid access spout until solution reaches the spout neck. Verify solution maintains level at the spout neck. Allow solution to remain in unit for 15 minutes.
5. Remove right side panel to access and clean the condenser.
6. Submerge dispense chute, drip tray and drip tray grill in the remainder of solution for 2 minutes. Rinse with clean, potable water.
7. Drain system by lowering drain tube into bucket. Return drain tube back into position.

8. Rear drain units: Disengage the storage bin drain tube pinch clamp until cleaning solution is drained, then engage the storage bin drain tube pinch clamp.
9. (UI 12) Fill and drain twice with potable water. Unit can be filled by pressing the Dispense Water button on the user interface or fill manually through ice bin lid. Return drain tube back into position when complete
Rear drain units: Disengage the storage bin drain tube pinch clamp when complete.
Hot tank units: Disengage the hot tank vent tube pinch clamp when complete.
10. Place a bucket under the dispense chute and remove cap. Caution: Some solution will remain and drain out when cap is removed.
11. (UI 13) When the Cleaning and Sanitizing procedure is finished, replace cap, lid, right side panel, cover, chute and drip tray. Press Complete on the user interface.
12. Dispense water for 5 seconds to rinse the dispense tube. (Hot water units: Dispense hot water for 5 seconds.)

Exterior Cabinet

1. To enter Cleaning Screen Mode, press ?.
2. Choose Clean Screen, then Lock.
3. Clean the user interface screen using a damp - not wet - nonabrasive cloth and mild detergent, if necessary.
4. Press and hold the unlock button to unlock the user interface.

Clean the User Interface Screen

Clean Screen Mode (Dispensing Disabled) - Use when cleaning surface

Entering Clean Screen Mode disables the User Interface and allows you to clean the outside of the dispenser without accidentally dispensing ice and/or water.



1. To enter Cleaning Screen Mode, touch the Follett logo (**Fig. 32.1**), then touch  (**Fig. 32.2**), then touch the Follett logo again (**Fig. 32.3**).
2. Choose *Maintenance*, then *Clean Screen*, then *Lock*
3. Clean the user interface screen using a damp - not wet - nonabrasive cloth and mild detergent if necessary.
4. When done, choose *Unlock* for approximately 5 seconds and then press .

Fig. 32



Fig. 33



Operation

Note: If "Touchless" is activated, simply placing a finger near the button will cause dispensing.

To dispense ice

1. Place cup under ice/water dispense chute.
2. Touch "ICE" button in center of circle. Once depressed, ice will start dispensing into glass on user interface and into cup placed under ice chute.
3. Maximum continuous dispense is 60 seconds. If more ice is needed, release and touch ice dispense once again.
4. Once cup is filled to desired level, release button and remove cup.

Fig. 34

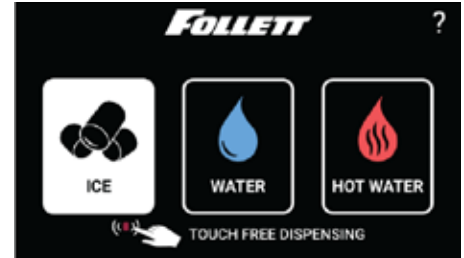

To dispense hot water



WARNING!

Boiling water can cause severe burns. Use caution when dispensing.

1. Place cup under ice/water dispense chute.
2. Touch "HOT WATER" button. Once touched, a secondary safety menu will be displayed.
3. Press and hold "HOT WATER" button. Once cup is filled to desired level, release button and remove cup.
4. After button is released, screen will return to home screen in approximately 5 seconds.

Fig. 35



To dispense water

1. Place cup under ice/water dispense chute.
2. Touch "WATER" button in center of circle. Once depressed, water will start dispensing into glass on user interface and into cup placed under ice chute.
3. Maximum continuous dispense is 60 seconds. If more water is needed, release and water ice dispense once again.
4. Once cup is filled to desired level, release button and remove cup.

User Interface

From the Home screen, touch the Follett logo, then touch , then touch the Follett logo again.

Maintenance	
Clean Screen	<ul style="list-style-type: none"> ▪ Lock screen, clean User Interface with a damp (not wet) non abrasive cloth and unlock screen when finished.
Clean and Sanitize	<ul style="list-style-type: none"> ▪ Follow cleaning procedure outlined in service manual and on bottom side of top cover ▪ Reset cleaning PM Timer
Replace Filter	<ul style="list-style-type: none"> ▪ Remove old filter turning counterclockwise and install new filter turning clockwise ▪ Reset filter PM Timer

Preventive Maintenance Interval (see Preventive Maintenance Setting table that follows)	▪ Adjust from 1 to 6 month interval based on water chemistry in 1 month increments (Default 6 months)
Filter Interval	▪ Adjust from 1 to 6 month interval based on water chemistry in 1 month increments (Default 6 months)
Operation Settings	
Sleep Mode	▪ Adjust from 0 to 240 minutes in 20 minute increments (default is 240 minutes)
Language	▪ Select English, Espanol, Francais (default is English)
Brightness	▪ Adjust brightness from 10 to 100 in increments of 5 (Default 80)
Hot Water Temp	▪ Temperature adjusts from 100 F to 185 F degrees in 1 degree increments (Default 180 F)
Service	
TDS Flush Cycle (future)	▪ Low range = 10 to 200 TDS, Hi range is 201 to 400 TDS (Default 10-200)
Time Delay	▪ Short range = 15 minutes, Long range = 30 minutes (Default is 15 minutes)
Wake On Dispense	▪ Adjust from 0 to 120 seconds in 1 second increments (Default is 35 s)
Flush Enabled (future)	▪ Time Delay ▪ Self ▪ Shuttle
Screen Timeout	▪ Adjust from 30 to 300 seconds in increments of 30 seconds (Default 120 s)
System Information	
Model Number	▪ EXAMPLE: 7CI112A
Serial Number	▪ EXAMPLE: L54179
Water Filter	▪ INSTALLED/NOT INSTALLED
Drain (drip tray/ice bin)	▪ INSTALLED/NOT INSTALLED ▪ Drip tray drain ▪ Ice bin drain
Hot Water	▪ INSTALLED/NOT INSTALLED
Ambient Water	▪ INSTALLED/NOT INSTALLED
IMC Software Version	▪ Version #
UI Software Version	▪ Version #
Troubleshoot	
Drip Tray Full	▪ Remove drip tray, empty water, clean and dry tray and terminals before re-installing
Low Water	▪ Contact Service
Water Leak	▪ Contact Service
Event Log	▪ Tracks events as they occur
Manual QR Code	▪ Scan QR code with smart phone to access service manuals

Preventive Maintenance Setting

To determine the correct preventive maintenance interval for your application, use either the TDS or Hardness tables below. If you use both the TDS and Hardness and your values are not the same, Follett recommends that you use the lowest value (shortest interval). Without evidence of regular preventive maintenance, warranty will be void. Unit needs to be installed with proper filtration system that provides TDS/hardness within Follett specifications.

TDS - ppm	
TDS Range (ppm)	PM Schedule (Months)
10 to 150	6
151 to 250	4
251 to 350	3
351 to 400	2
401 and above	RO/Filtration Required

Hardness - ppm	
Hardness Range (ppm)	PM Schedule (Months)
0 to 60	6
61 to 120	4
121 to 180	3
181 to 200	2
201 and above	RO/Filtration Required

Evaporator Disassembly

1. Disconnect power from the dispenser.
2. Turn off water supply to dispenser.
3. Remove (unscrew) chrome ice dispenser chute (Fig. 36.1).
4. Remove the drip tray (Fig. 36.2).
5. Remove the two screws (Fig. 36.3) on the front panel (behind the drip tray).
6. Remove and set aside the front panel (Fig. 36.4). Do not disengage the plug on the back of the User Interface.
7. Lift and remove the top panel, set aside (Fig. 36.5).
8. Remove two screws (Fig. 36.6) and remove left side panel. Remove two screws and remove right side panel.

Fig. 36

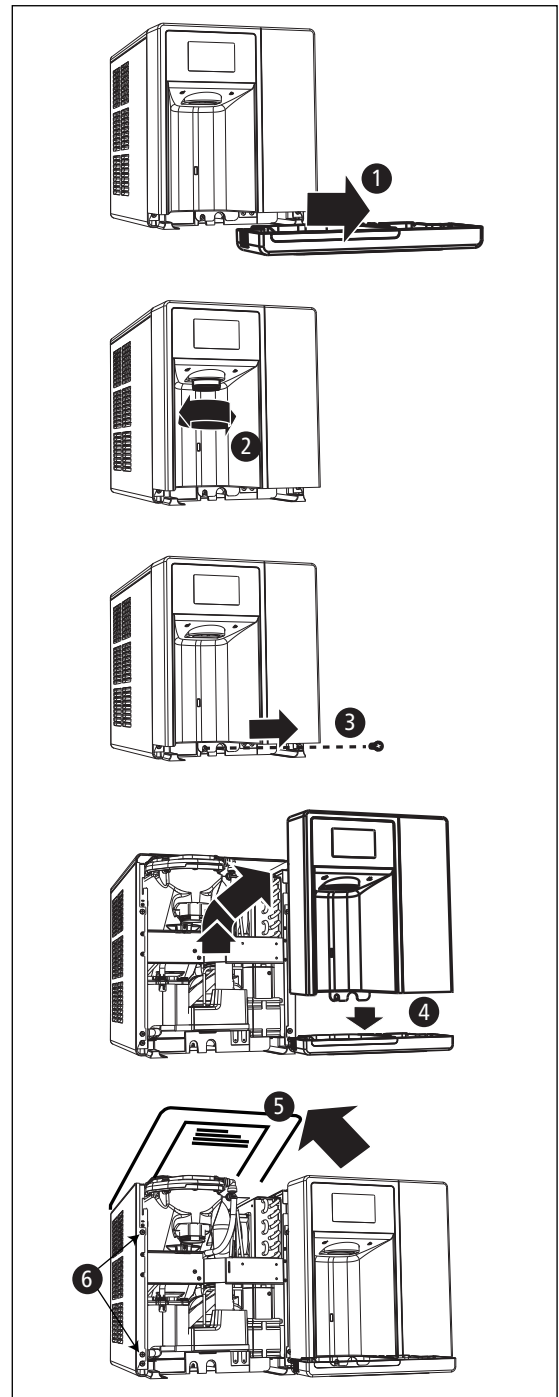

9. Unplug the gear motor (three connectors) (Fig. 37).
10. Remove ground screw connection.

Fig. 37

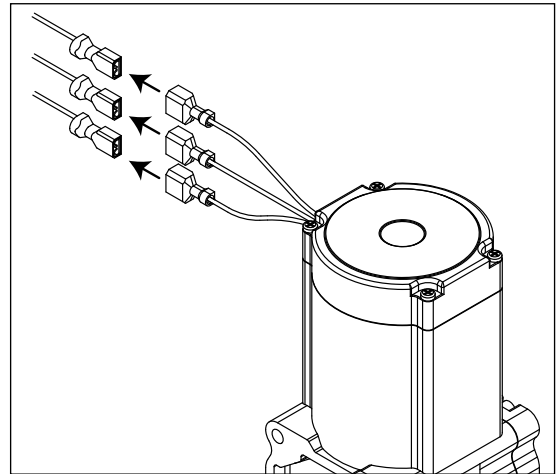

11. Remove compression nozzle:
 - Loosen hose clamp (Fig. 38.1).
 - Remove transport tube (Fig. 38.2).

Fig. 38

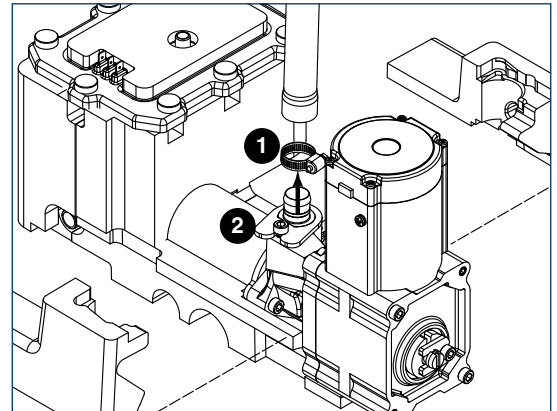

12. Remove M6 socket head allen screw (Fig. 39.1).
13. Remove compression nozzle retainer (Fig. 39.2).
14. Remove compression nozzle (Fig. 39.3).

Fig. 39

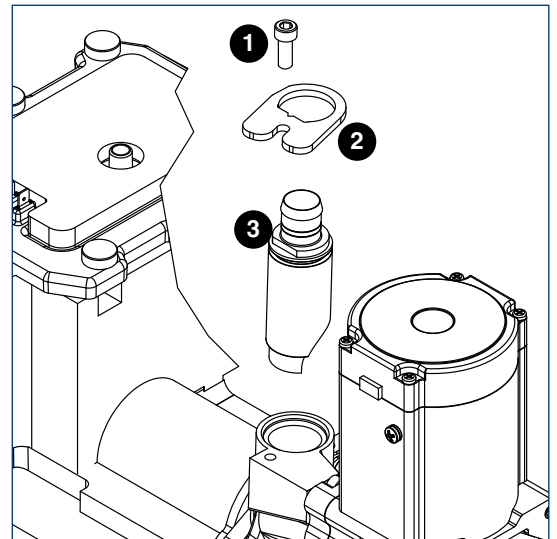

15. Remove gear motor:

- Remove M6 allen screw, retainer, spacer and key (Fig. 40.1).
- Remove two M6x90 allen screws (Fig. 40.2).
- Pull gear motor from auger (Fig. 40.3).
- Remove main housing insulation (Fig. 40.4).

16. Remove all traces of Petrol-gel from auger shaft.

Fig. 40

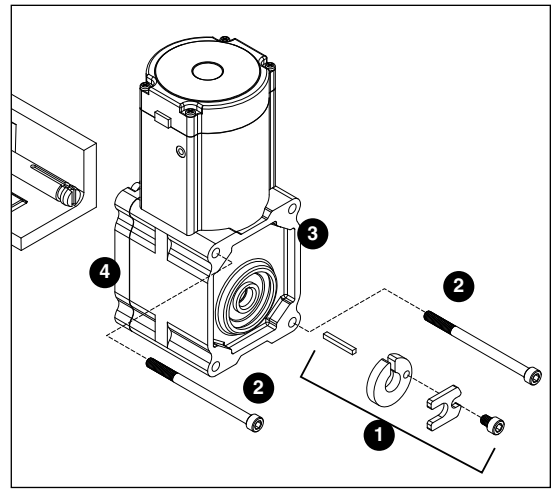

17. Remove main housing:

- Disconnect vent line from T fitting (Fig. 41.1).

Fig. 41

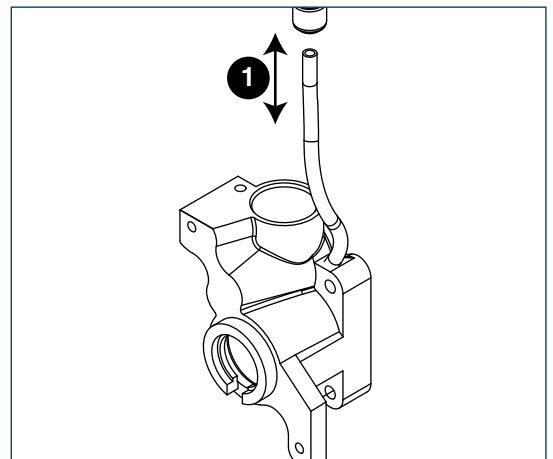

18. Remove three M6x25 socket head allen screws (Fig. 22.1).

19. Remove main housing (Fig. 42.2).

Fig. 42

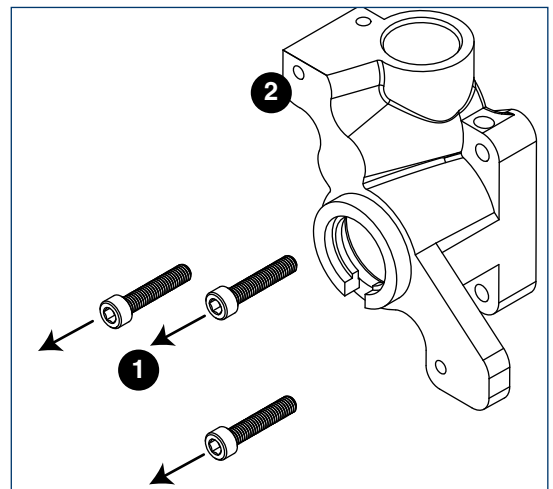

20. Remove and discard mating ring and seal (**Fig. 43.1**).
21. Carefully remove auger (**Fig. 43.2**).



WARNING!

Use caution when removing auger. The auger is very sharp - handle with care to avoid personal injury.

Evaporator Assembly

1. Remove and inspect main housing O-ring seal. Replace if damaged in any way.
2. Clean O-ring groove. Lubricate O-ring with Petrol-gel and reinstall.
3. Use cardboard disc to press new mating ring into main housing (**Fig. 44.1**).
4. Lube the shaft with liquid soap in the area shown (**Fig. 44.2**) and slip on seal and spring (**Fig. 44.3**).
 - Note:** Do not touch the sealing surfaces with bare hands. Contact with bare skin will cause premature seal failure.
5. Install auger (**Fig. 44.4**).
6. Install main housing:
 - Slide main housing onto auger shaft (**Fig. 45.1**).
 - Install three M6x25 allen screws (**Fig. 45.2**).
 - Connect vent line to T fitting (**Fig. 45.3**).

Fig. 43

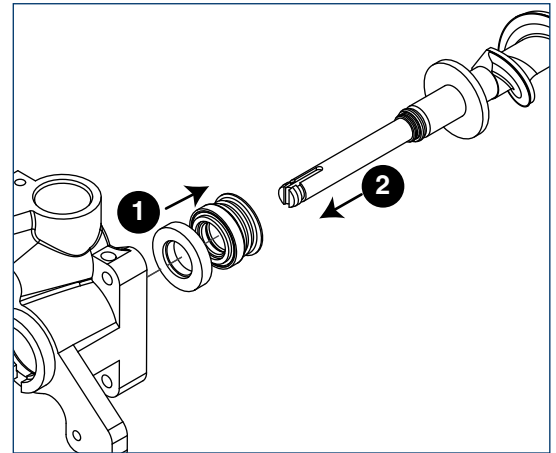

Fig. 44

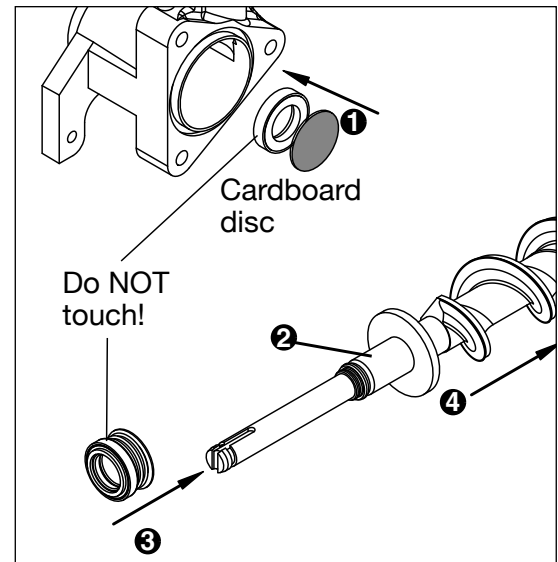
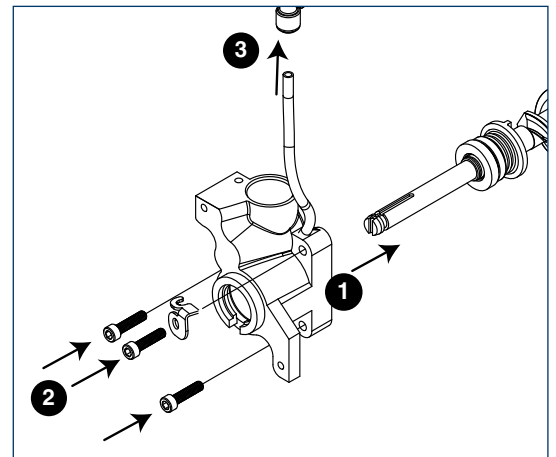

Fig. 45



7. Install compression nozzle:

- Remove and inspect compression nozzle O-ring seal. Replace if damaged in any way.
- Clean O-ring groove. Lubricate O-ring with Petrol-gel and reinstall.
- Install compression nozzle (**Fig. 46.1**).
- Install compression nozzle retainer (**Fig. 46.2**).
- Install M6 socket head allen screw (**Fig. 46.3**).

Fig. 46

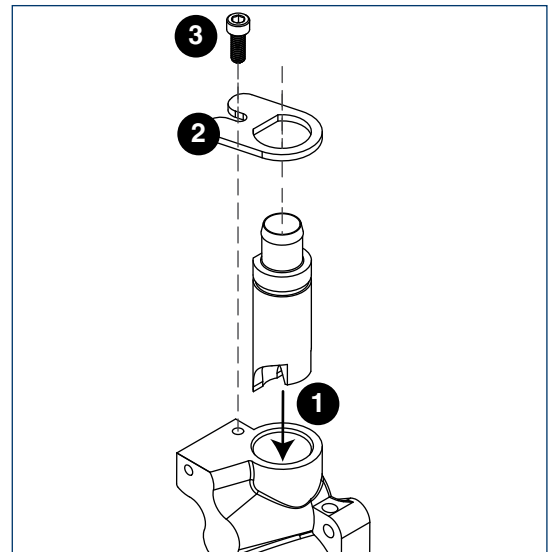

8. Install transport tube (**Fig. 47.1**).

9. Tighten hose clamp (**Fig. 47.2**).

Fig. 47

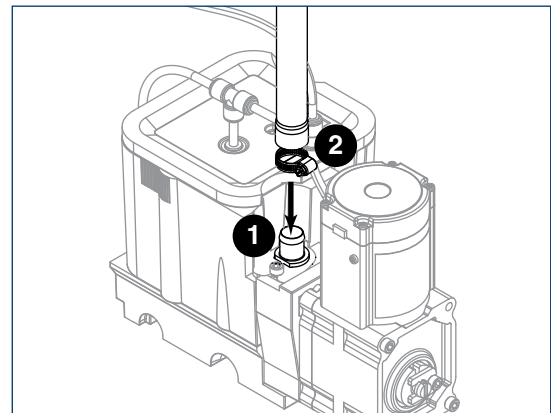

10. Install gear motor:

- Install main housing insulation (**Fig. 48.1**).
- Slide gear motor onto auger shaft (**Fig. 48.2**).
- Install two M6x90 allen screws (**Fig. 48.3**).

Fig. 48

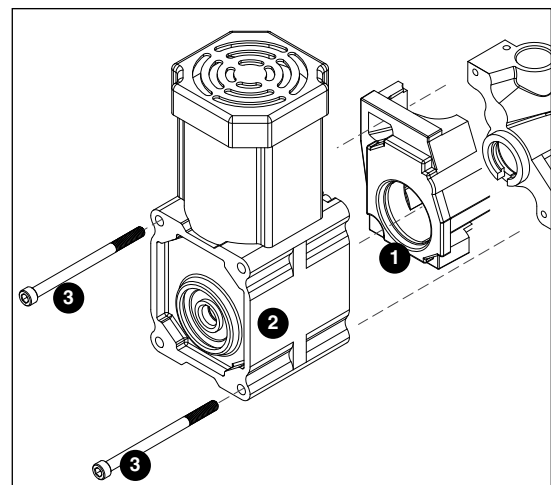

11. Use screwdriver to orient auger shaft to align with motor shaft keyway (**Fig. 49.1**).
12. Install key into keyway (**Fig. 49.2**).

Fig. 49

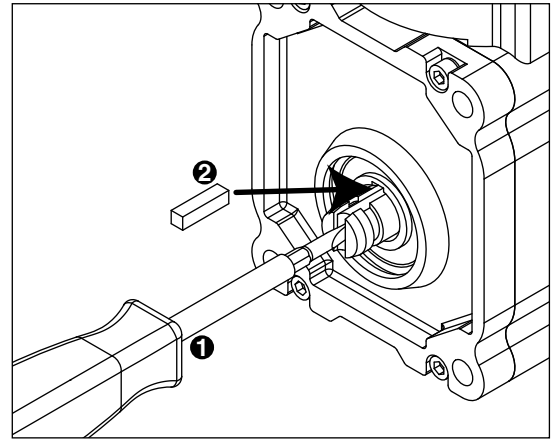

13. Install spacer, ensure that key is captured in slot (**Fig. 50.1**)

Fig. 50

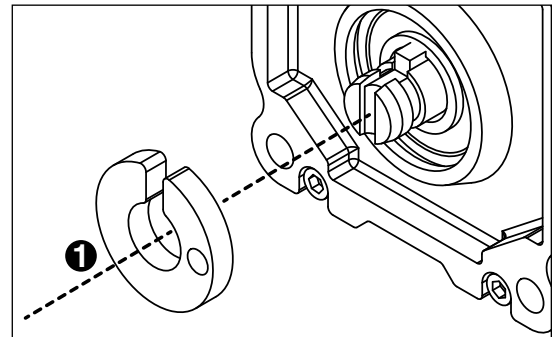

14. Insert screwdriver into groove of auger shaft and pry shaft outwards (**Fig. 51.1**).
15. Insert retainer into groove (**Fig. 51.2**), ensure that retainer is aligned with hole in spacer.

Fig. 51

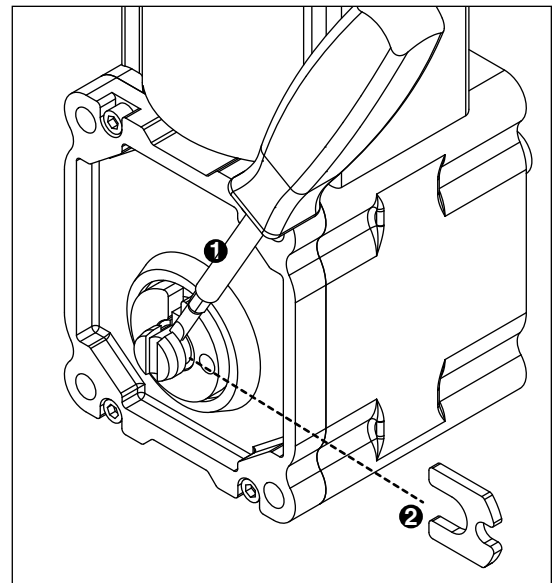

16. Install screw and tighten (**Fig. 52.1**).

Fig. 52

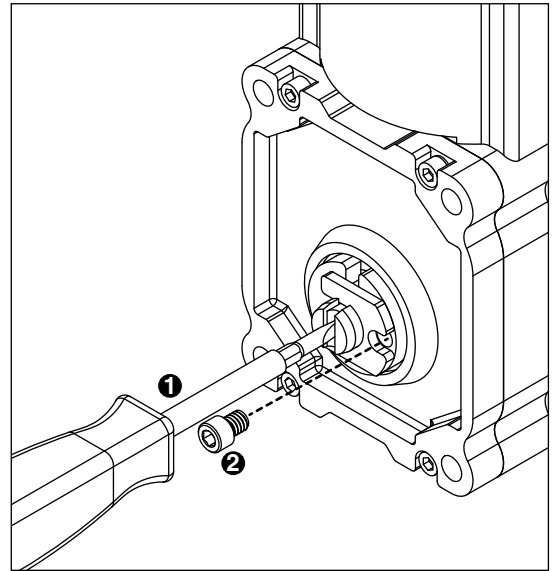

17. Plug in gear motor (**Fig. 53**).

- BLUE to BLUE
- BLACK to BLACK
- WHITE to WHITE
- Connect ground wire with ground screw.

Fig. 53

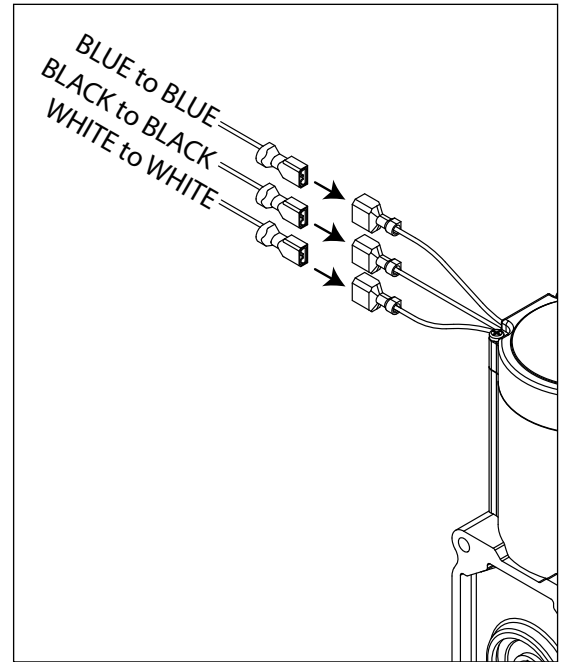

Water Feed Schematic (Hot Water Tank)

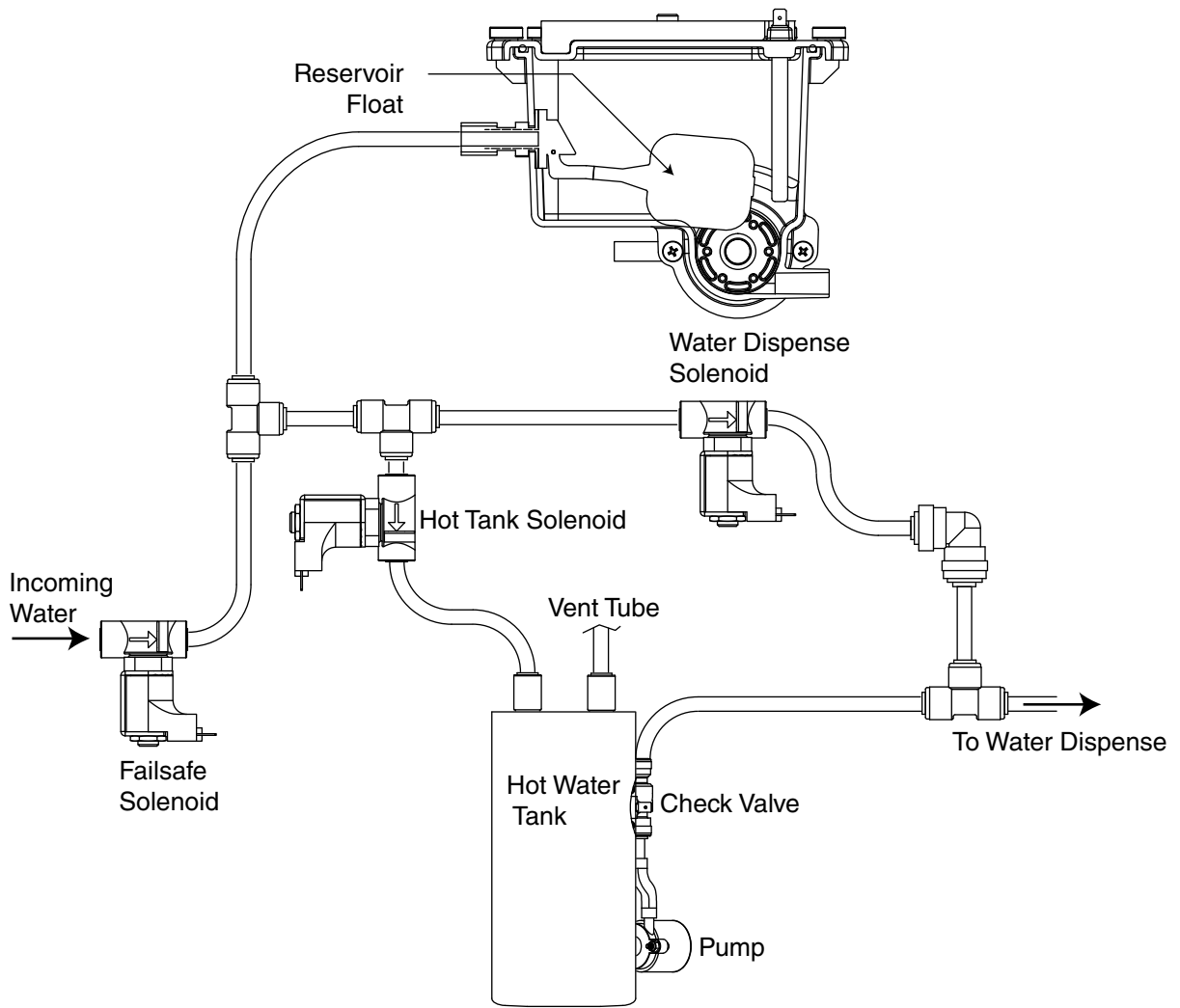

Water Feed Schematic (Claris Filter)

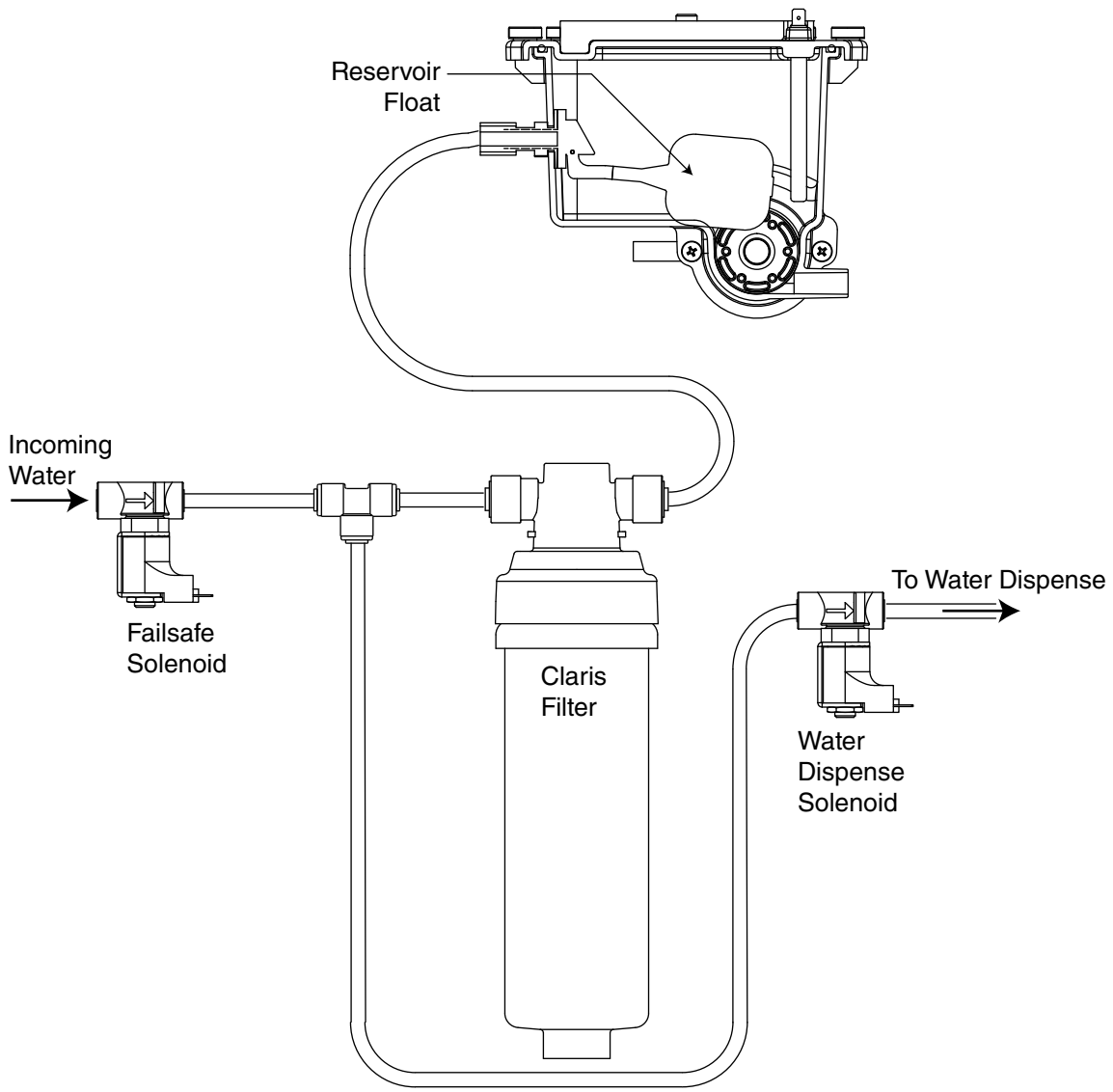

Bin Melt Water/Evaporator Feed/Clean Out System Schematic

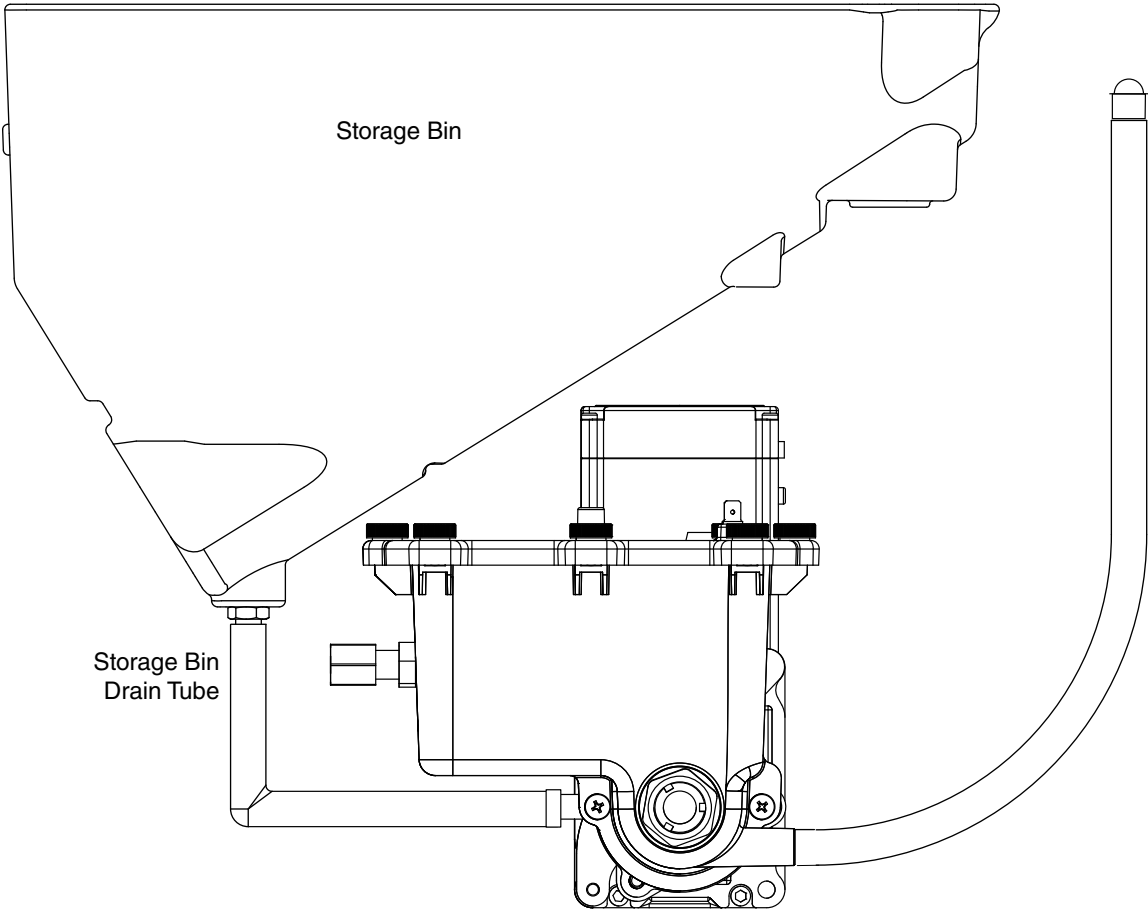

Bin Melt Water/Evaporator Feed/Clean Out System Schematic - Rear Drain

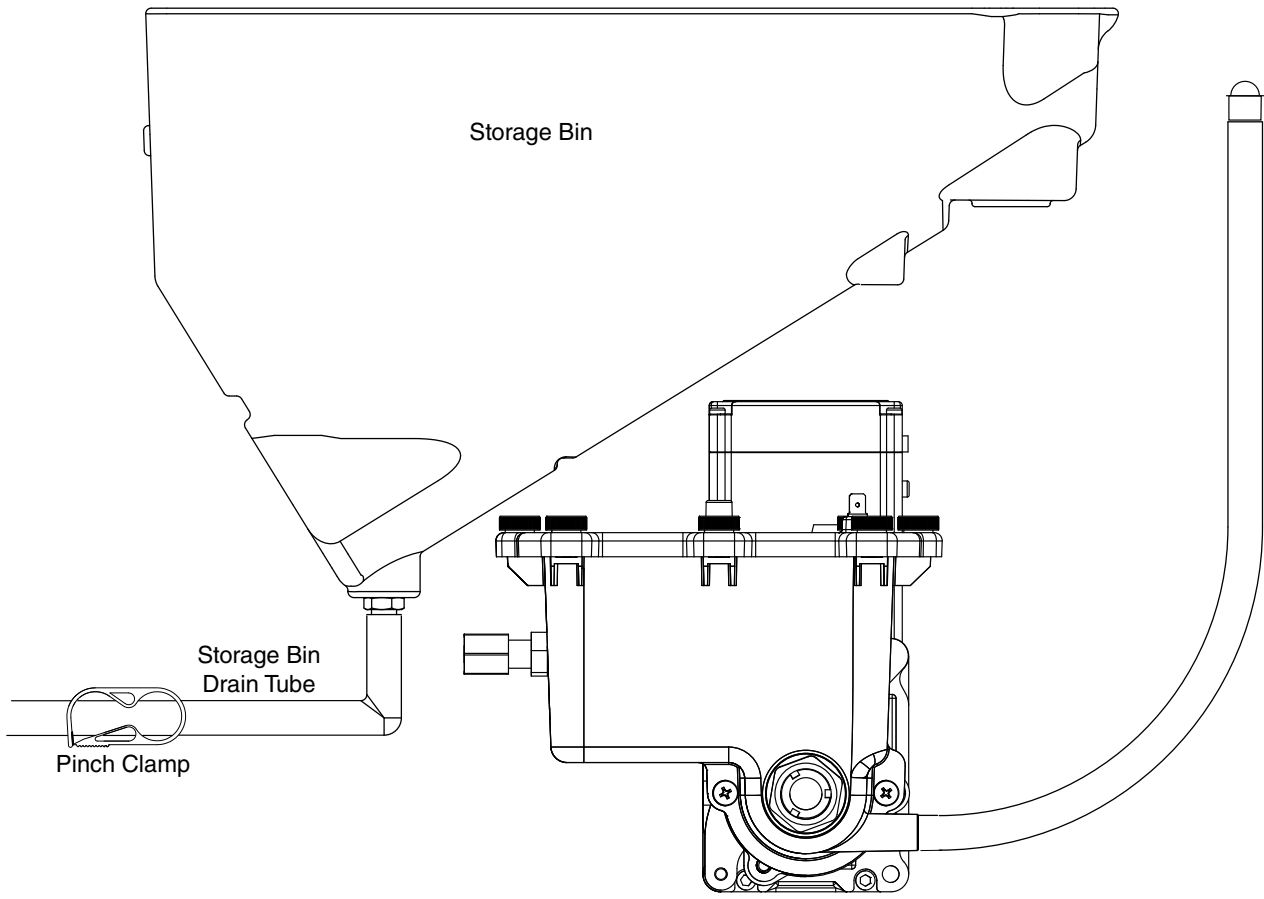

Vent System Schematic

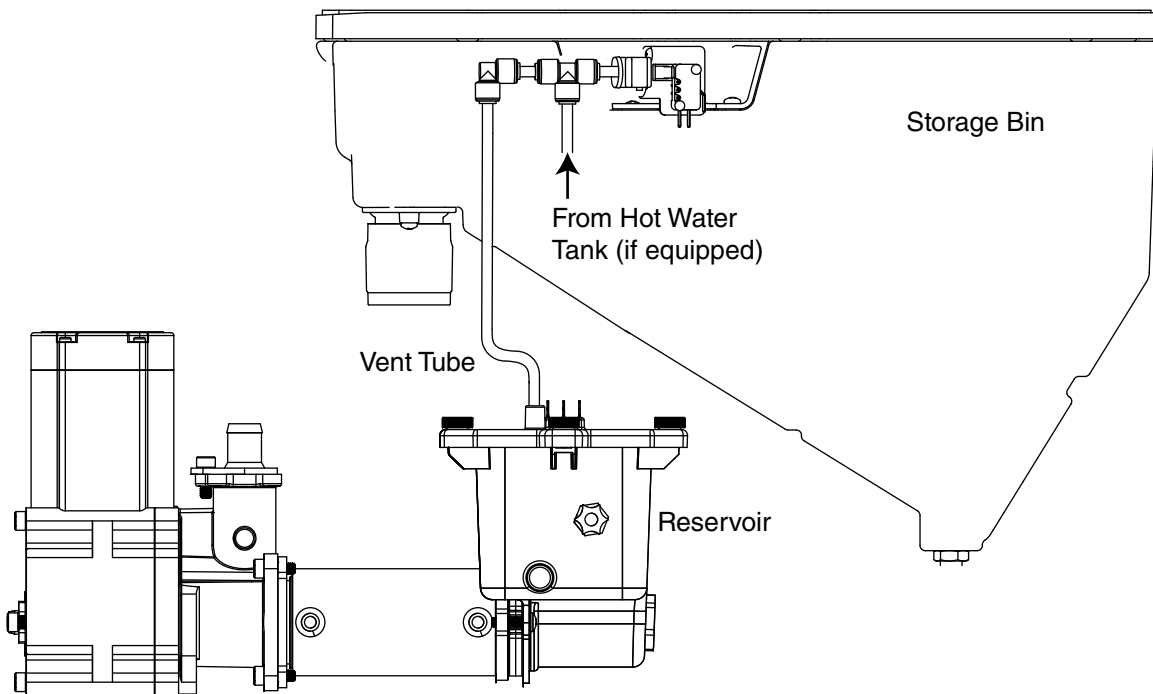

Refrigeration Schematic

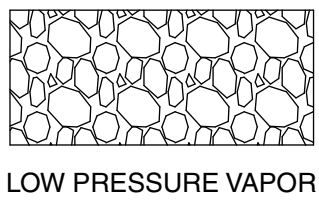
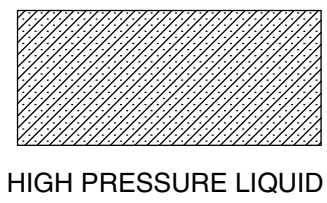
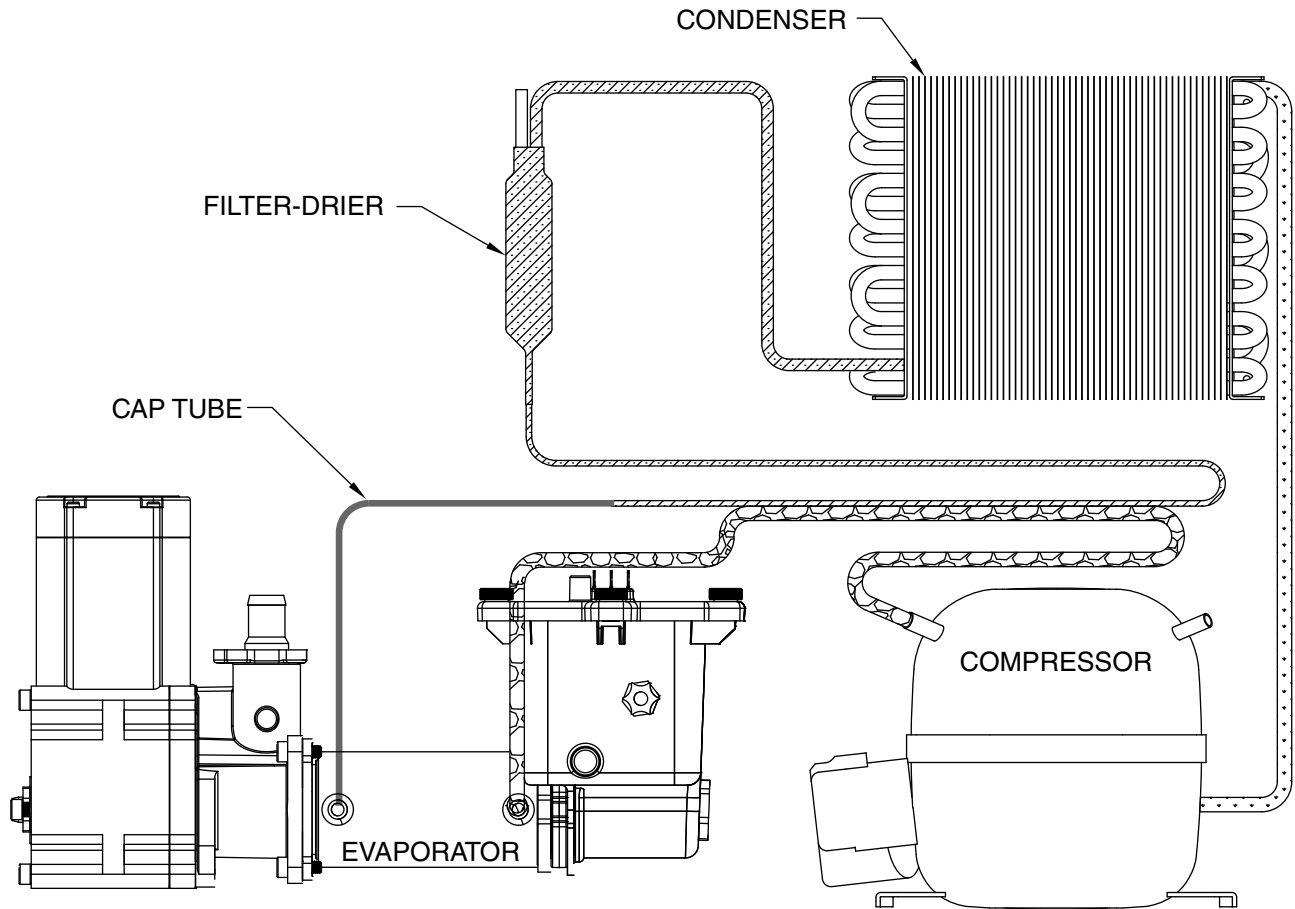

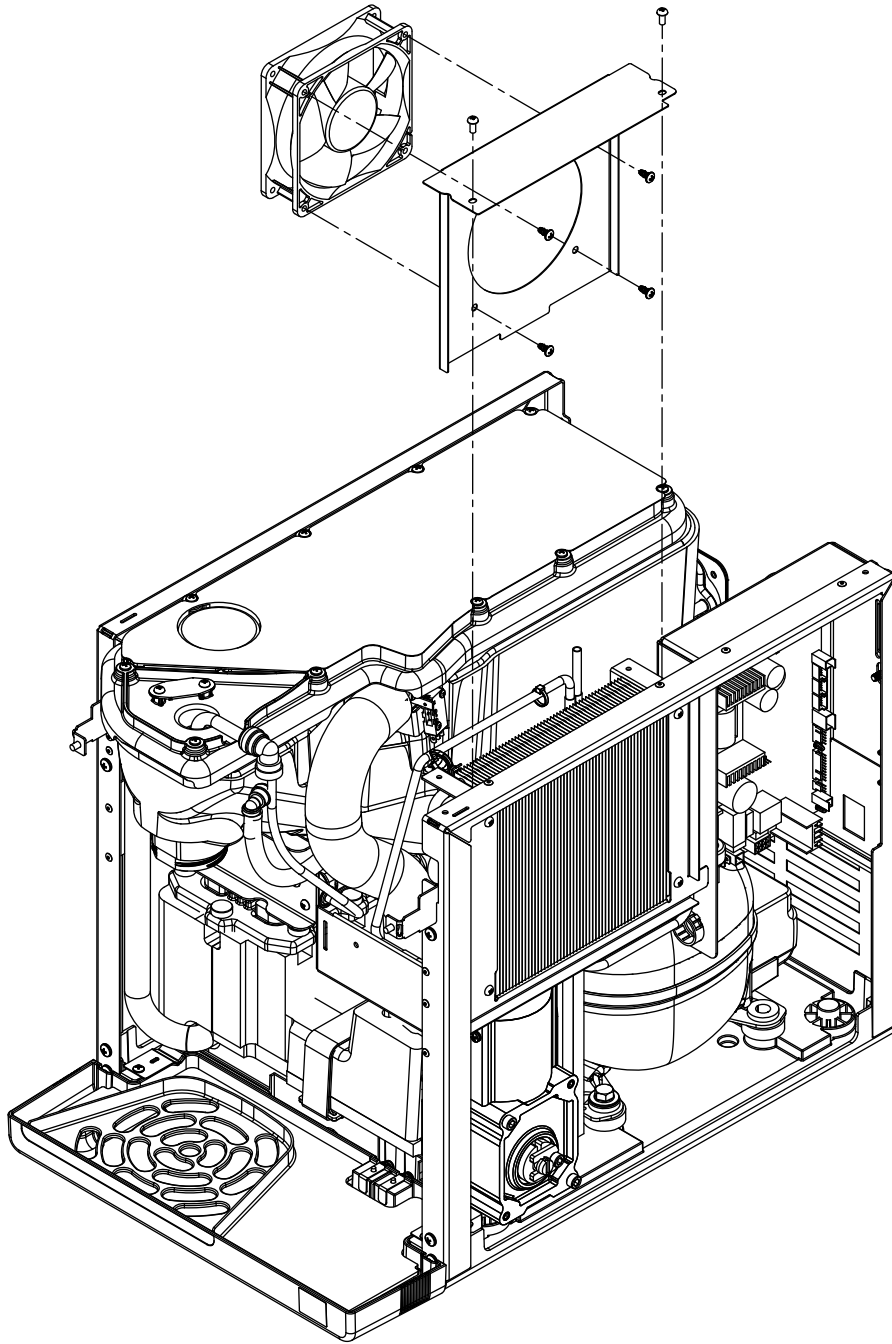

Condenser Fan Motor Removal (Champion 7 Shown)



User Interface Alerts

Fig. 54 Interface Alert Examples



Interface Display	Condition	Remedy
Alert Type 1		
Clean and Sanitize	Maximum 6 month maintenance required (Adjustable 1 to 6 months)	Follow PM cleaning procedure in service manual and reset timer
Filter Replacement Required	Maximum 6 month filter replacement required (Adjustable 1 to 6 months)	
Low Water	Reservoir sensors are not detecting water	Verify water is turned "ON" and internal filter has been installed. If this does not correct problem, unit will need to be serviced
Alert Type 2		
Empty Drip Tray	Drip tray full of water contacting tray sensors	Empty drip tray, dry tray/terminals and reinstall
Alert Type 3		
Internal Water Leak Detected	Unit has internal water leak contacting chassis sensors	<ul style="list-style-type: none"> ▪ Dry chassis, locate leak and repair ▪ Reset from user interface menu (Follett, , Follett), Service → Advanced → enter access code → Control Board Reset → yes →  ▪ Or, reset control board manually by pressing reset button

Machine Status

Procedure for viewing status indicators: From the Home screen, touch  to enter help screen. Status will be displayed on right side of screen.

Fig. 55 Help Screen Example



Interface Display	Condition	Remedy
Time Delay	Ice bin is full and unit is placed into 15 minute time delay (15 or 30 minutes)	After 15 minutes unit will exit time delay
Sleep Mode	If unit has not be used during time delay, unit will enter sleep mode (adjustable 0 to 240 minutes).	To exit sleep mode you must dispenser ice for 35 seconds of accumulated time
Making Ice	Normal ice operation	Normal ice operation
Flush Enabled	Future	Future
Low Bin	Ice bin shuttle micro switch activated	This indicates full bin of ice. Inspect bin and take corrective action if bin is not full
Low Water	Reservoir sensors are not detecting water	Verify water is turned "ON" and internal filter has been installed. If this does not correct problem, unit will need to be serviced

Control Board Output LEDs and Connections

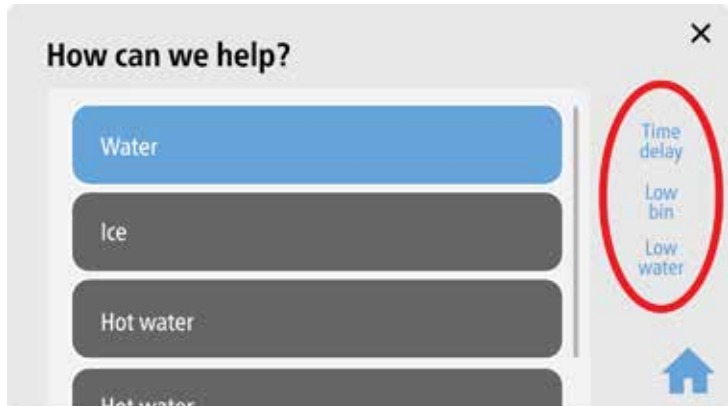
Status LED	Function	Power	Connector	Pins	Input/Output
1	Power "ON"	5 VDC	Internal	—	Internal
2	Auger Gear Motor	120/220 VAC	CN5	1, 2 Cap, 8	Output
3	Compressor	120/220 VAC	CN5	4, 5	Output
5	Condenser Fan	24 VDC	CN6	1, 2	Output
6	Failsafe Solenoid	24 VDC	CN6	3, 4	Output
8	Ice Dispense Auger Motor	120/220 VAC	CN5	3, 6	Output
9	Water Dispense Solenoid	24 VDC	CN6	5, 6	Output
10	Reservoir UV LED/Interlock	24 VDC	CN6	7, 8	Output
11	Hot Tank Output Heating Coil	120/220 VAC	CN7	1, 2	Output
12	Hot Tank Fill Solenoid	24 VDC	CN12	1, 2	Output
13	Hot Water Dispense Pump	24 VDC	CN12	3, 4	Output
14	Heart Beat (Program)	5 VDC	Internal	—	Internal
15	Spare Output # 1 (VDC)	24 VDC	—	—	Future
17	Spare Output # 2 (Drain)	24 VDC	—	—	Future
18	Dispenser LED VYV Light - Blue	24 VDC	CN14	1, 2	Output

Symptom (End User)	Alert	Problem (ASA)	Resolution
Water Leak	Alert Type 3	Water has entered the chassis and has contacted chassis water sensors	Step 1) Remove all water from chassis and sensor terminals. Power unit "OFF" and back "ON" to reset condition or reset by pressing control board reset switch (this is a hard fail).
			Step 2) Enter diagnostic mode, system input status and verify if chassis water sensor has check mark which means system is seeing water on terminals
			Step 3) Inspect incoming water connection at back of unit for leaks
			Step 4) If unit has internal filter, verify it has been inserted correctly and is not leaking
			Step 5) If unit doesn't reset, disconnect CN3 from control board and once again power unit "OFF" and back "ON". If Water Leak error does not reset, replace control board
			Step 6) With cable CN3 still disconnected from control board, ohm check between both wires going from sensors to control board (pins 9 & 10) and clean terminals of water and scale build-up located on chassis or replace cable assembly. This should read infinity but If there is a reading between these two wires, repair wires or replace
			Step 7) Fill ice bin with water, inspect for leaks and make necessary repairs as needed
			Step 8) Install seal kit as needed

Symptom (End User)	Alert	Problem (ASA)	Resolution
Drip Tray Error	Alert Type 2	Water in drip tray is contacting water sensors	Step 1) Remove and empty water from drip tray, clean and dry. Once drip tray is removed, error condition should automatically reset. Place unit back in operation
			Step 2) If error does not reset when drip tray is removed, check contacts on chassis for water and dry as needed
			Step 3) If error does not reset, enter diagnostics mode, system input status and verify if drip tray sensor is checked indicating sensors are detecting water
			Step 4) If drip tray sensor is activated, disconnect the cable CN3 going to control board and ohm check between both wires going from sensors to control board. This should read infinity but If there is a reading between these two wires, pull wires off water sensors and clean terminals of water and scale build-up or replace cable assembly
			Step 5) After removing CN3 cable if empty drip tray error display does not go away, replace control board
Not making ice	Alert Type 1	Low Water	Step 1) Verify external water valve is turned "ON"
			Step 2) If unit has internal filter, was it installed?
			Step 3) Verify unit can dispense water if available?
			Step 4) Enter diagnostic mode, system output tests to verify if failsafe water valve is activated
			Step 5) Using a flashlight, verify water is in the reservoir
			- No water, inspect failsafe solenoid has 24 VDC when activated and also solenoid was installed correctly with arrow on valve base aimed towards inside of unit. Remove screws and rotate 180 degrees if backwards. Check resistance of failsafe solenoid coil (101 ohms)
			- No water, Inspect float is not stuck in the up position and replace float if stuck
			- Yes, check orange wire on reservoir sensors is connected to middle terminal
			- Yes, short black and yellow terminals together. If low water goes out, inspect water sensors in reservoir for scale build up and clean as needed. If low water does not go out, ohm out wire from reservoir to control board to ensure good connections and replace if needed
- Yes, remove CN3 connector from control board and short out pins 9 & 10 on control board. If low water condition does not go away, replace board			

Symptom (End User)	Alert	Problem (ASA)	Resolution
Not making ice	Status	Low bin is OFF and Time Delay is displayed	Step 1) Is ice bin full? If ice bin is full and unit is in time delay or sleep cycle (this is normal)
			Step 2) If ice bin is low or no ice, enter diagnostics mode, system input status and toggle bin switch to verify operation. Inspect shuttle assemble for free movement and disassemble and apply grease to free up movement.
			Step 3) Using ohm meter test micro switch and cable assembly. Replace component if found defective
			Step 4) Replace control board if everything else checks out
Not Making Ice	Status	Not making ice (No indications on user interface)	Step 1) Verify external water valve is "ON" and internal filter is installed if supplied
			Step 2) Is unit powered "ON"?
			Step 3) Is unit in time delay or sleep cycle? (If yes, this is normal)
			Step 4) Is low bin indicator displayed and is bin full of ice?
			- If Low bin is not displayed and bin is full, this is normal
			- If Low bin is not displayed and bin is not full of ice. Check shuttle assemble for sticking and ohm check micro switch (Wired normally open, wires on common and normal open terminals)
			Step 5) Inspect vent tubes, reservoir fill tube and connecting ports for blockage due to scale build-up (this could starve evaporator of water and freeze up). A frozen capillary tube is also a sign of a starved evaporator.
			Step 6) Check if compressor is running, if not verify 120 VAC is being supplied to compressor. Check compressor overload/run relay. What is the current draw? Ohm check compressor windings C-R, C-S, R-S, R-S-C to frame
Step 7) Suspect defective compressor/refrigerant leak. Feel copper lines to see if they are room temperature. (Escalate to product specialist for next steps)			

Symptom (End User)	Alert	Problem (ASA)	Resolution
Not Making Ice	Event Log	Not making ice (Hi Amp Condition)	Check the following items :
			Step 1) Review event log for possible hi amp conditions (Note: unit will attempt to restart after 1 hour)
			Step 2) Check current draw on gear motor (Amp draw of 0.55 amp will create over current condition - Hi Amp)
			- Unit needs to be cleaned due to scale build-up (when was the last PM performed?)
			- Blocked or worn ice transport tube
			- Defective compression nozzle
			- Defective shuttle assembly (mechanically binding or defective micro switch(
			- Defective gear motor (drawing zero or higher amperage)
			- Defective start capacitor
			- Auger hitting inside of evaporator barrel (check end bushing)
			- Check for drop in incoming voltage + or - 10% (is unit on dedicated line?)
			- Dull or scaled up auger
- Evaporator being starved of water (check for blockage in reservoir end bushing and vent tubes)			
Not Dispensing Water	N/A	Not Dispensing Water	Step 1) Verify external water valve is turned "ON"?
			Step 2) If unit has internal filter, was it installed?
			Step 3) Depress water dispense button on user interface, does water dispense into cup?
			Step 4) Can you hear water dispense solenoid energizing when user interface button is depressed?
			- Yes, remove 1/4" tubing at input of dispense solenoid and place into cup. Turn unit back "ON" and re-test. If water is present, inspect dispense solenoid was installed correctly with arrow on valve base aimed towards dispense nozzle. If all checks good, replace dispense solenoid.
			- No, verify LED 9 on control board lights when depressing user interface water dispense button
			- No, verify 24 VDC is at solenoid terminals when button is depressed and Inspect wiring and water dispense solenoid (101 ohm) with ohm meter. Replace wiring, solenoid or control board based on findings

Symptom (End User)	Alert	Problem (ASA)	Resolution
Not Dispensing Ice	N/A	No ice can be dispensed	Step 1) Verify external water valve is turned "ON"?
			Step 2) If unit has internal filter, was it installed?
			Step 3) Depress water dispense button on user interface, does water dispense into cup?
			Step 4) Can you hear ice dispense motor energizing when user interface button is depressed and is auger turning?
			- No, verify LED # 8 on control board is lighting when ice dispense button is depressed and if it lights, verify 120 VAC is at motor terminals when button is depressed, inspect wiring with ohm meter. If all checks OK, replace dispense motor
			- Yes, Make sure auger is engaged with motor and ice is not bridged. If ice is present and auger will not turn, replace motor.
Hot Tank - Not Dispensing Water	N/A	No hot water is dispensing	Step 1) Verify external water valve is turned "ON"?
			Step 2) If unit has internal filter, was it installed?
			Step 3) Depress hot water dispense button on user interface, does hot water dispense into cup?
			Step 4) Enter diagnostics mode and toggle Hot Water Dispense Pump "ON", is pump activating?
			- Yes, verify hot tank fill solenoid is functioning properly and tank is filled with water
			- Yes, replace hot tank pump
- No, verify Hot Water Dispense Pump LED 13 on control board is "ON". If yes, check 24 VDC going to dispense pump and replace pump if present.			

Symptom (End User)	Alert	Problem (ASA)	Resolution
Hot Tank - Not dispensing hot water	N/A	Water is not hot	1) Enter diagnostics mode - Input screen, verify hot water tank low water sensor is checked indicating water is present (if not checked, tank is not filled with water or sensor is defective and heater will not - Output screen, hot water fill valve turns "ON" when hot water is dispensed and turns "OFF" when water reaches the high sensor. Note: If sensor is inoperative the unit will flood with
			Step 2) Verify LED 11 on control board is "ON". With a multimeter, verify 120 VAC (black wire) is at heating element. Note: Hot tank must have water filled to low water sensor (white wire) closest to front of unit. This can be tested by momentarily grounding white wire to the frame while monitoring for 120 VAC going to the heating element during power up. If heating element reads 120 VAC, tank may not have water or low water sensor is scaled and not sensing water. Verify hot tank fill solenoid is functioning and hot tank is filled with water.
			Step 3) With power "OFF", remove wire from overload and ohm check overload making sure it is not tripped causing an open circuit
			Step 4) Verify user interface setting for hot water temp is set at 180 degrees (180 degrees is default)
			Step 5) If all checks good, replace hot tank
UV Light/ Interlock	N/A	Build-up of bacteria in reservoir	Step 1) Enter diagnostics mode and toggle UV light on and off (Note: do not look directly at the light when testing)
			Step 2) Does UV light come "ON"
			- No, does LED # 10 on control board light? Replace control board if light does not come "ON"
			- No, Using multimeter, ohm check interlock is closed when blocked with small flat blade screwdriver
			- No, verify 24 VDC is being supplied to UV light. If yes, drain unit and replace UV light.
- If 24 VDC is not present, ohm out cable and replace UV light if no continuity is found. If cable is good, replace control board			

Symptom (End User)	Alert	Problem (ASA)	Resolution
Water leaking from Ice/Water chute	N/A	Water collecting in ice bin or leaking out of Ice/Water dispense chute	Step 1) Verify pressure of the incoming water line (10 PSI Min/70 PSI max). If pressure is too high, a pressure regulator will need to be installed.
			Step 2) Inspect reservoir float is functioning properly and gasket seal is present
			Step 3) Inspect vent tubes are not scaled up and blocked causing a vapor lock. Repair or replace tubing. (water level will keep rising as water is dispensed)
No User Interface Display	N/A	No display on User Interface	Step 1) Verify unit is turned "ON"
			Step 2) Is there power to the unit? (check power to outlet)
			Step 3) Verify control board has power. (Is power LED # 1 "ON"). You can also carefully check that you have 120 VAC on pins 1 & 2 of connector CN4 (be careful)
			Step 4) Remove cable going to CN10 and verify you have 24 VDC on pins 1 & 4 on control board
			Yes - Replace cable and User Interface
			No - Replace control board
Unit Squealing	N/A	Unit is making squealing noise	Check the following items:
			- Unit needs to be cleaned due to scale build-up (check TDS/hardness and adjust PM schedule as needed)
			- Check if evaporator is being starved of water (check for blockage)
Ghost Dispensing Ice/Water/Hot Water	N/A	Water or ice keeps dispensing	Step # 1) Verify ground wire is attached to user interface frame
			Step # 2) Replace user interface, interface cable and control board
No touchless dispensing	N/A	No water or ice dispensing with touchless	Step # 1) Verify touchless dispensing is turned "ON" (make sure to save settings and reset UI)
			Step # 2) Verify correct sensitivity settings, th = 35, dg = 4, ag = 0, hy = 1
			Step # 3) Wrong firmware on control board (replace control board)

Reported Symptom	Soft Alert	Problem	Resolution
Unit is in Time Delay	Time Delay	Not making ice	<p>Step 1) Ice bin full, this is normal (15 minute delay/default - adjustable)</p> <p>Step 2) Ice bin not full, check ice transport tube shuttle is not stuck, disassemble and lube shuttle for proper operation.</p> <p>Step 3) Ice bin not full, ohm check shuttle micro switch and wire to control board and replace if found defective.</p> <p>Step 4) Replace control board.</p>

Unit is in Sleep Cycle	Sleep Mode	Not making ice	<p>Step 1) If unit is not used when in time delay, it will enter sleep cycle (4 hours/default - adjustable).</p> <p>Step 2) To exit sleep cycle, ice must be dispensed for 35 seconds of accumulated time - default (this time is adjustable).</p> <p>Step 3) To exit sleep cycle, perform a reset on control board or dispense ice. Replace control board if sleep cycle will no go away.</p>
Unit is in Stand-by	Stand-by	Not making ice	Unit will stay in stand-by mode for 15 minutes to protect compressor. Unit can be placed back in operation by powering off and back on or performing a control board reset.
PM Alert	Alert Type 1	Soft PM alert	Soft alert indicating it's time to perform PM on the unit. Perform cleaning and sanitizing procedure per service instructions (default is 6 months - adjustable).
Filter Change Alert	Alert Type 1	Soft filter change alert	Soft alert indicating it's time to change water filter. Replace water filter and flush per service instructions (default is 6 months - adjustable)

Miscellaneous

Description	Part #
Claris Filter	01548635
SafeCLEAN Plus, case of 6	01149954
SafeCLEAN Plus, case of 24	01149962

Exterior - Champion 7

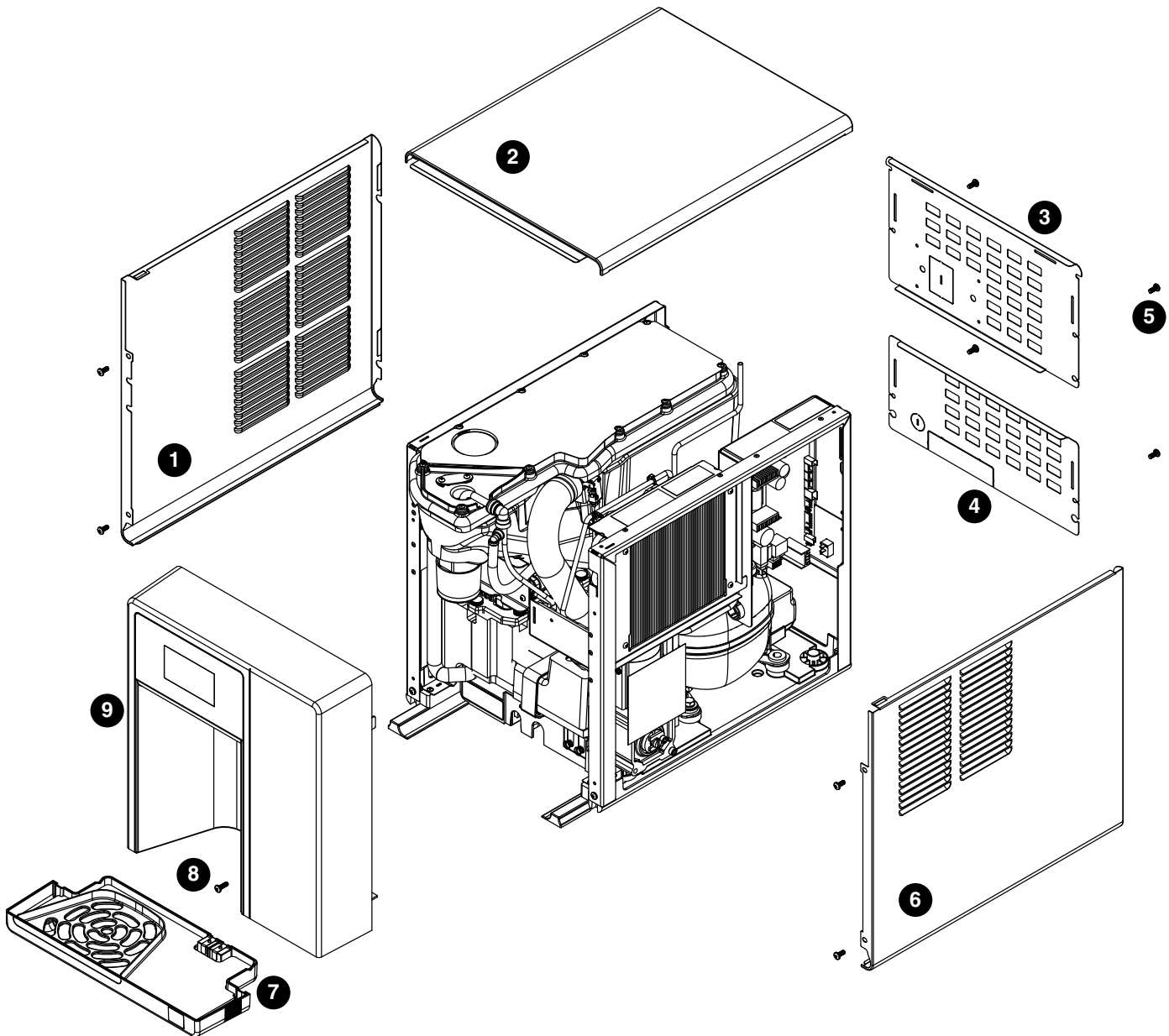

Exterior - Champion 7

Reference #	Description	Part #
1	Panel, Left	01535954
2	Panel, Top Panel	01535939
3	Panel, Back Upper	01535962
4	Panel, Back Lower	01535970
5	Screw, Phillips Pan HD, 10-16x 1 (Qty 11)	01536010
6	Panel, Right	01535947
7	Drip Tray Assy	01535921
8	Screw, M5 X 16, Phillips Pan Head, (Blue)	01539097
9	Front Assembly, Champion 7	01535905
Not Shown	Drip Tray Drain Kit (not for UD or UC models)	01535335

Reference #	Description	Part #
Not Shown	Drip Tray Drain Kit with 4" legs	01535343

Interior - Champion 7

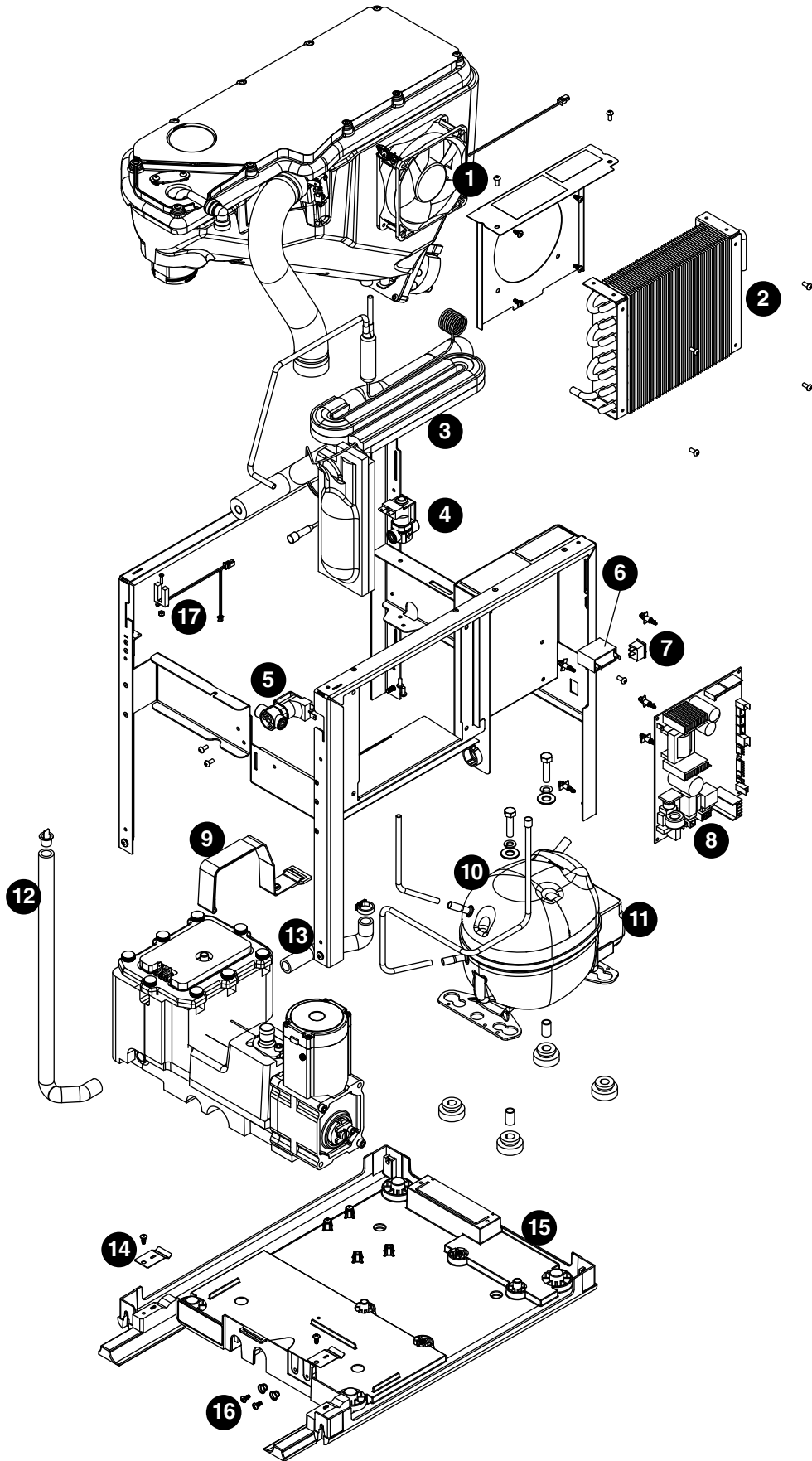

Interior - Champion 7

Reference #	Description	Part #
1	Condenser Fan, Cord and Hardware	01536143
2	Condenser	01536150
3	Heat Exchanger, Kit	01536168
4	Valve, Failsafe Solenoid	01536184
5	Solenoid, Water Feed, Champion 7/15	01536184
6	Capacitor, Gearmotor	01536200
7	Power Switch	01536218
8	Control Board with Stand-offs	01536226
9	Strap, Evaporator Module, Champion 7/15	01536259
10	Compressor with Mounting Hardware	01536234
11	Relay and Overload	01537307
12	Tube, Reservoir Drain, Champion 7/15	01536267
13	Tube, Reservoir Ice Melt, Champion 7/15	01536242
14	Sensor, Retainer Hardware Kit	01536275
15	Chassis Assembly	01536291
16	Spring, Drip Tray Sensor, Champion 7/15	01536283
17	UV Interlock Magnetic Switch	01536192

Exterior - Champion 15

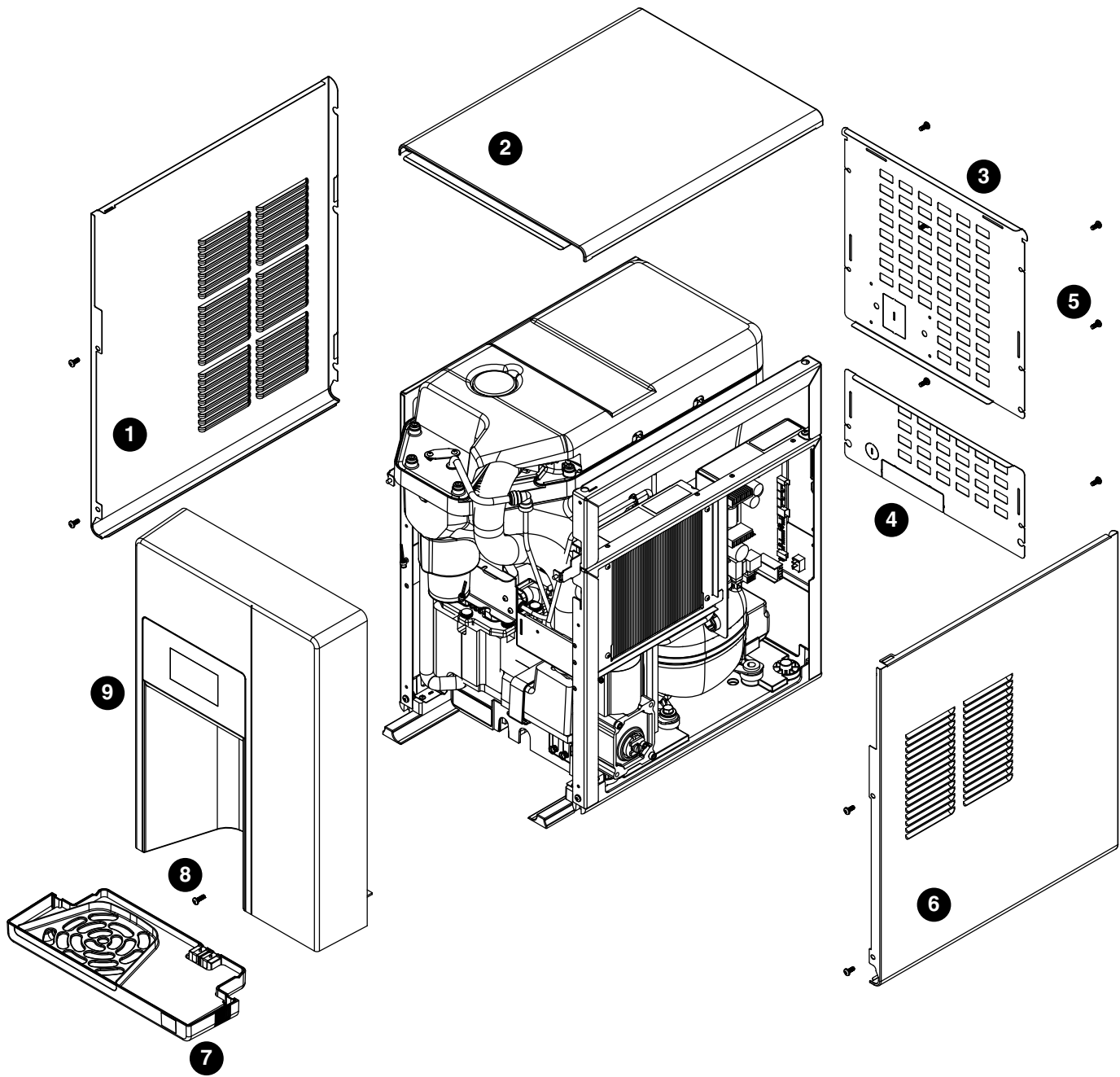

Exterior - Champion 15

Reference #	Description	Part #
1	Panel, Left	01536499
2	Panel, Top Panel	01535939
3	Panel, Back Upper	01536507
4	Panel, Back Lower	01535970
5	Screw, Phillips Pan HD, M5x12 (Qty 11)	01536010
6	Panel, Right	01536481
7	Drip Tray Assy	01535921
8	Screw, M5 X 16, Phillips Pan Head, (Blue)	01539097
9	Front Assembly, 15	01536473

Reference #	Description	Part #
Not Shown	Drip Tray Drain Kit (not for UD or UC models)	01535335
Not Shown	Drip Tray Drain Kit with 4" legs	01535343

Interior - Champion 15

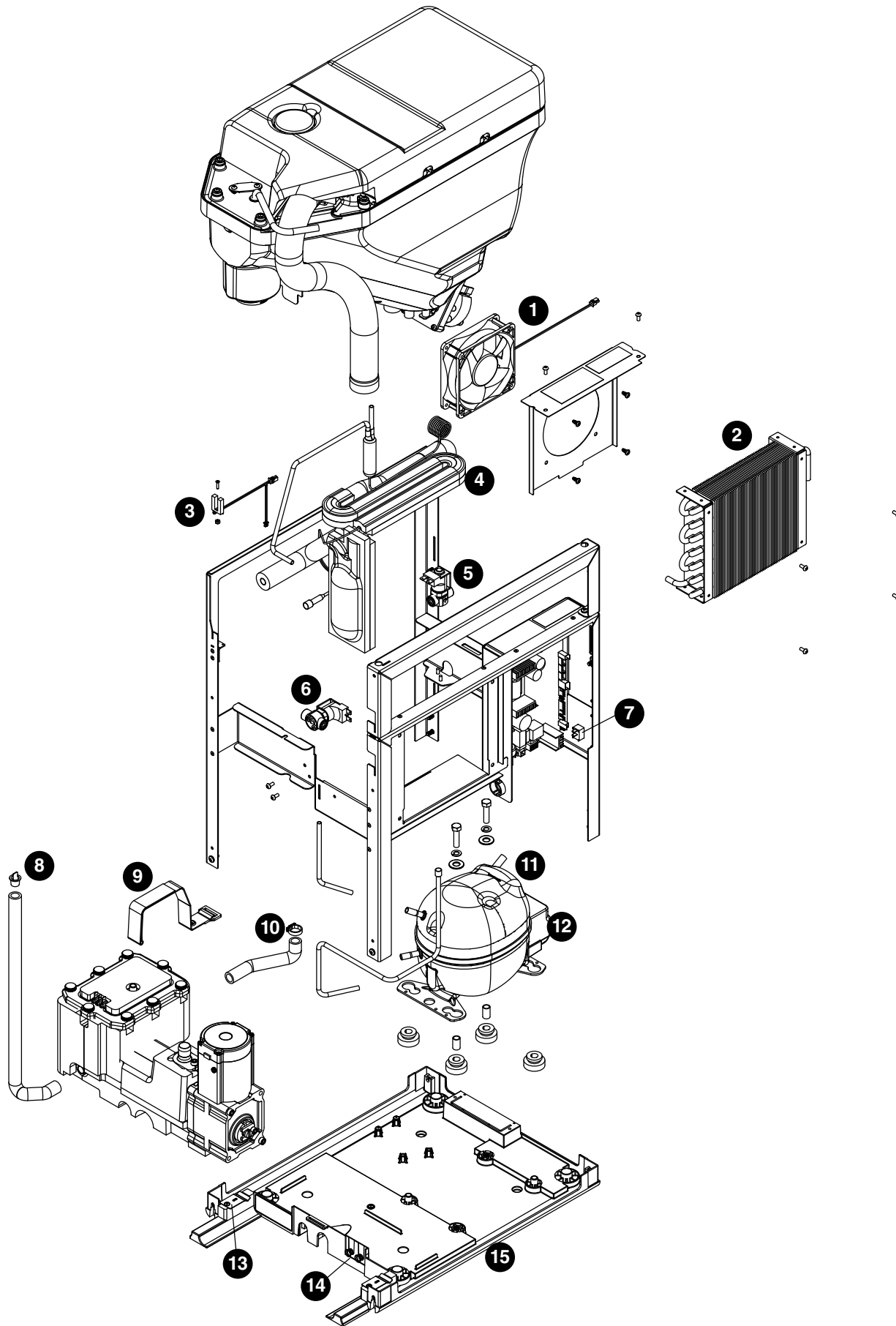

Interior - Champion 15

Reference #	Description	Part #
1	Condenser Fan, Cord and Hardware	01536143
2	Condenser	01536150
3	UV Interlock Magnetic Switch	01536192
4	Heat Exchanger, Kit	01536168
5	Valve, Failsafe Solenoid	01536184
6	Solenoid, Water Feed, Champion 7/15	01536184
7	Power Switch, Champion 7/15	01536218
8	Tube, Reservoir Drain, Champion 7/15	01536226
9	Strap, Evaporator Module, Champion 7/15	01536259
10	Tube, Reservoir Ice Melt, Champion 7/15	01536242
11	Compressor with Mounting Hardware	01536234
12	Relay and Overload	01537307
13	Sensor, Retainer Hardware Kit	01536242
14	Spring, Drip Tray Sensor, Champion 7/15	01536275
15	Chassis Assembly	01536291
Not shown	Capacitor, Gearmotor	01536200

Bin Assembly - Champion 7

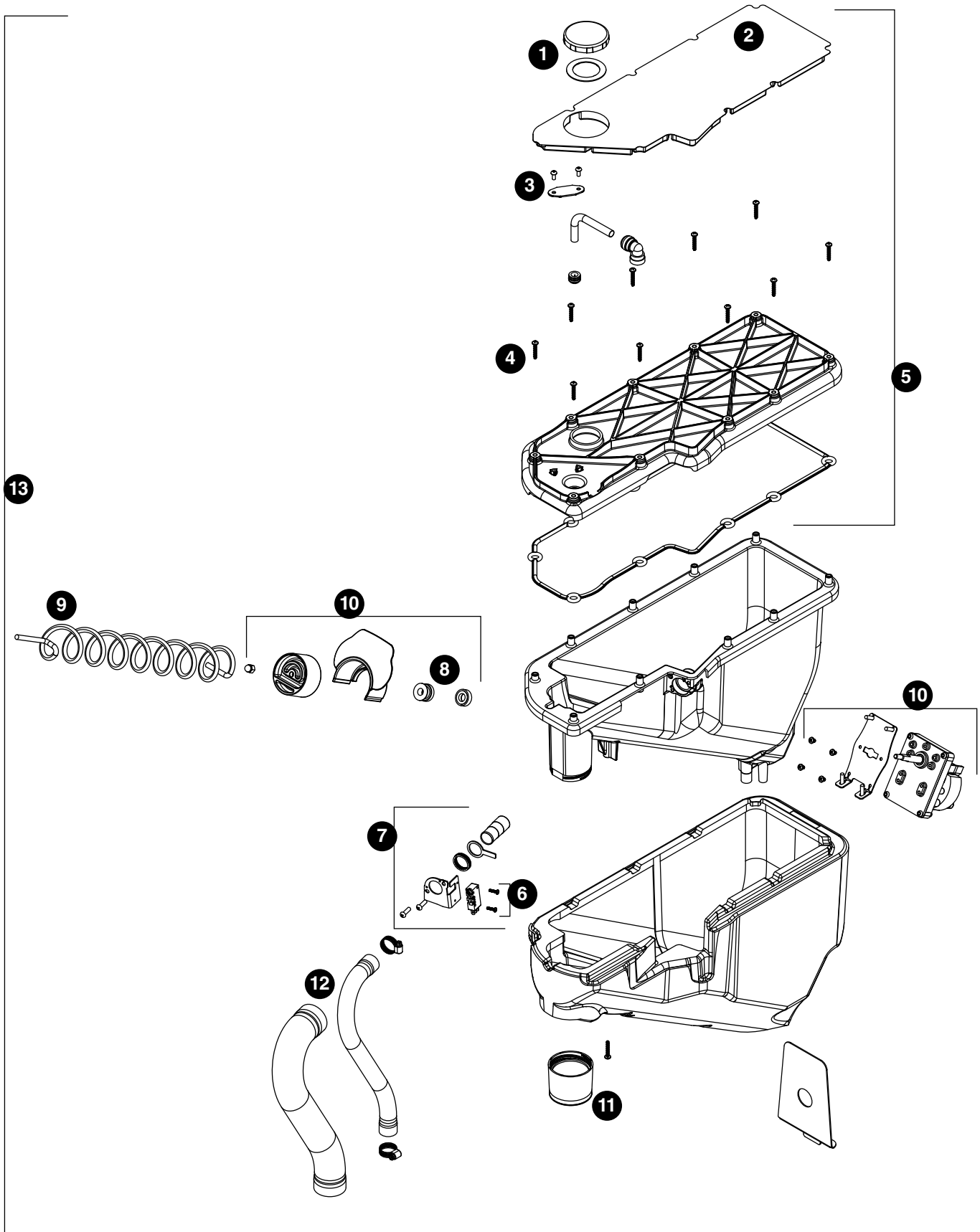

Bin Assembly - Champion 7

Reference #	Description	Part #
1	Cap and gasket	01535988
2	Bin Lid Insulation	01535996
3	LED Dispense	01535002
4	Bin Lid Screw (12)	01537471
5	Lid, Bin Assy	01536028
6	Switch, Shuttle	01536101
7	Shuttle Assembly	01536085
8	Seal	01536069
9	Auger, Dispense	01536036
10	Assembly, Motor Dispense	01536044
11	Ice Chute	01536119
12	Ice Transport Tubing with Insulation	01536077
13	Bin assembly, Champion 7 (does not include ice transport tube and insulation)	01536135

Champion 15 Bin Assembly

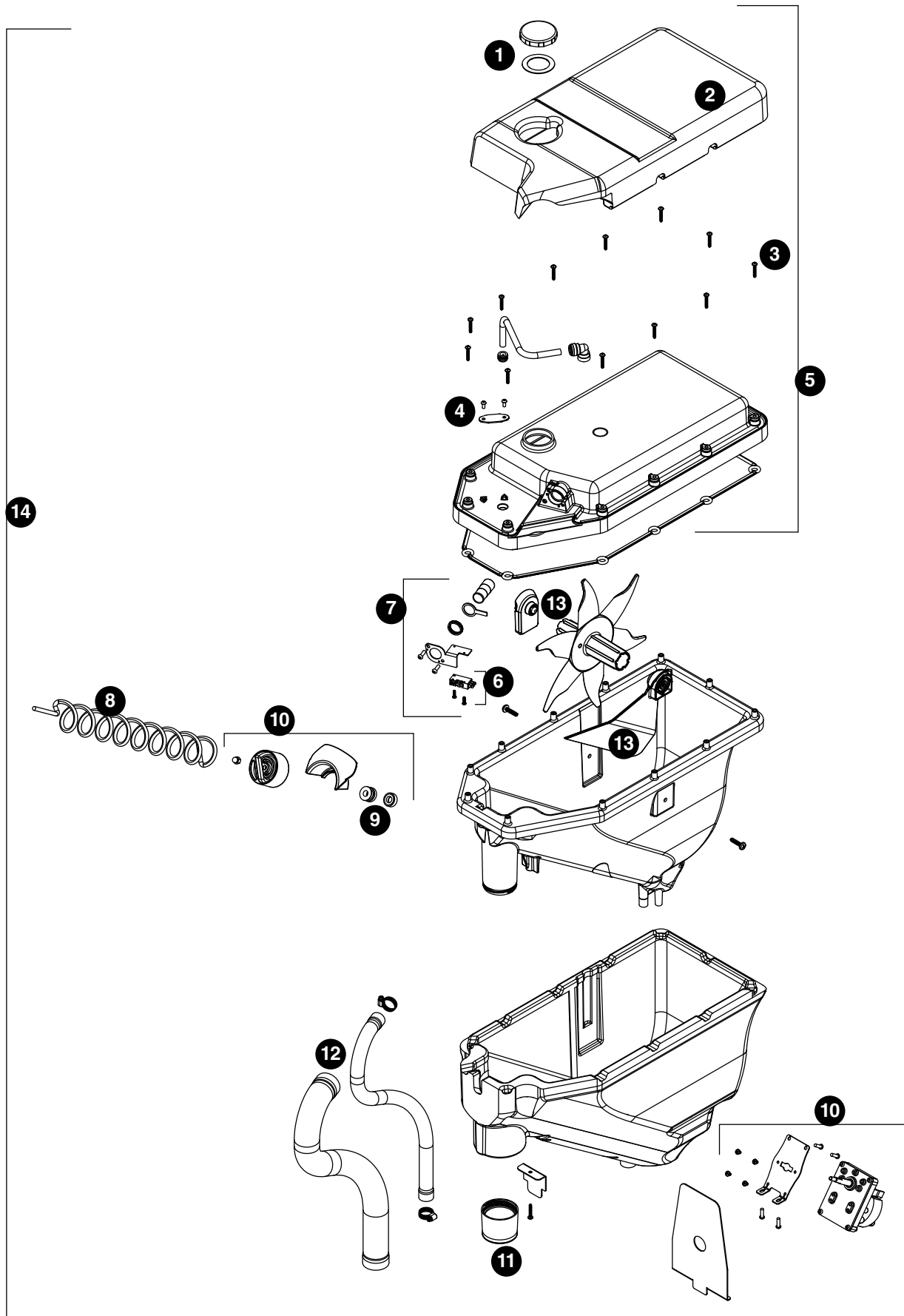

Bin Assembly - Champion 15

Reference #	Description	Part #
1	Cap and gasket	01535988
2	Bin Lid Insulation	01536515
3	Bin Lid Screw (12)	01537471
4	LED Dispense	01535002
5	Lid, Bin Assy	01536523
6	Switch, Shuttle	01536101
7	Shuttle Assembly	01536085
8	Auger, Dispense	01536531
9	Seal	01536069
10	Assembly, Motor Dispense	01536044
11	Ice Chute	01536119
12	Ice Transport Tubing with Insulation	01536549
13	Agitator, Ice Bin, Champion 15	01536556
14	Bin Assembly, Champion 15 (does not include ice transport tube and insulation)	01536564

Evaporator Assembly

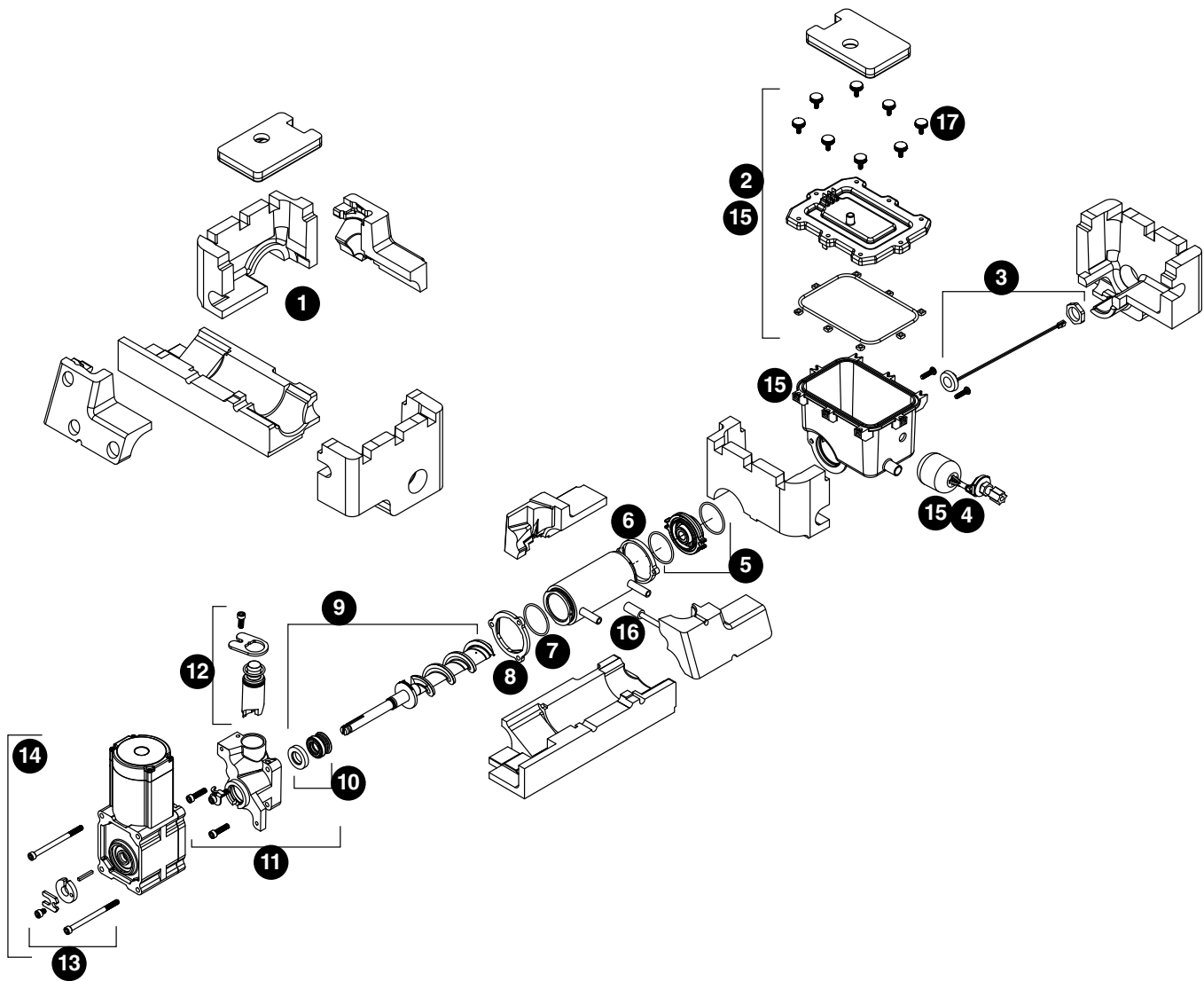

Evaporator Assembly

Reference #	Description	Part #
1	Insulation Kit (6 pieces)	01536309
2	Lid, Reservoir with Insulation and O-Ring (does not include bolt or insulation)	01536432
3	Light, UV	01536465
4	Float Valve	01536424
5	Housing, Bushing	01536416
6	Rear Flange Jacket	01536390
7	O-ring	01536408
8	Front Flange Jacket	01536382
9	Auger with front seal	01536366
10	Front Auger Seal and Spring	01536358
11	Main Housing with Front Seal, Screws, (includes vent tube, retainer and o-ring)	01536341
12	Ice Compression Nozzle Assy	01536374
13	Hardware kit, Gearmotor	01536325

Reference #	Description	Part #
14	Gearmotor assembly	01536333
15	Reservoir and Float Complete Assy (does not include insulation)	01536440
15	Reservoir and Float Complete Assy, Rear Drain Unit only (does not include insulation)	01554823
16	Thermistor, evaporator temperature	01545797
17	Hardware, Reservoir Lid (one M5 thumbscrew and one nut)	01536457
Not shown	Nut, reservoir lid nut (m5 x .8 x 4 mm)	01537422
Not shown	Tubing, reservoir vent tube 13.5"	01540905
Not shown	Tubing, reservoir vent tube 16.5"	01540913

Evaporator Seal Kit

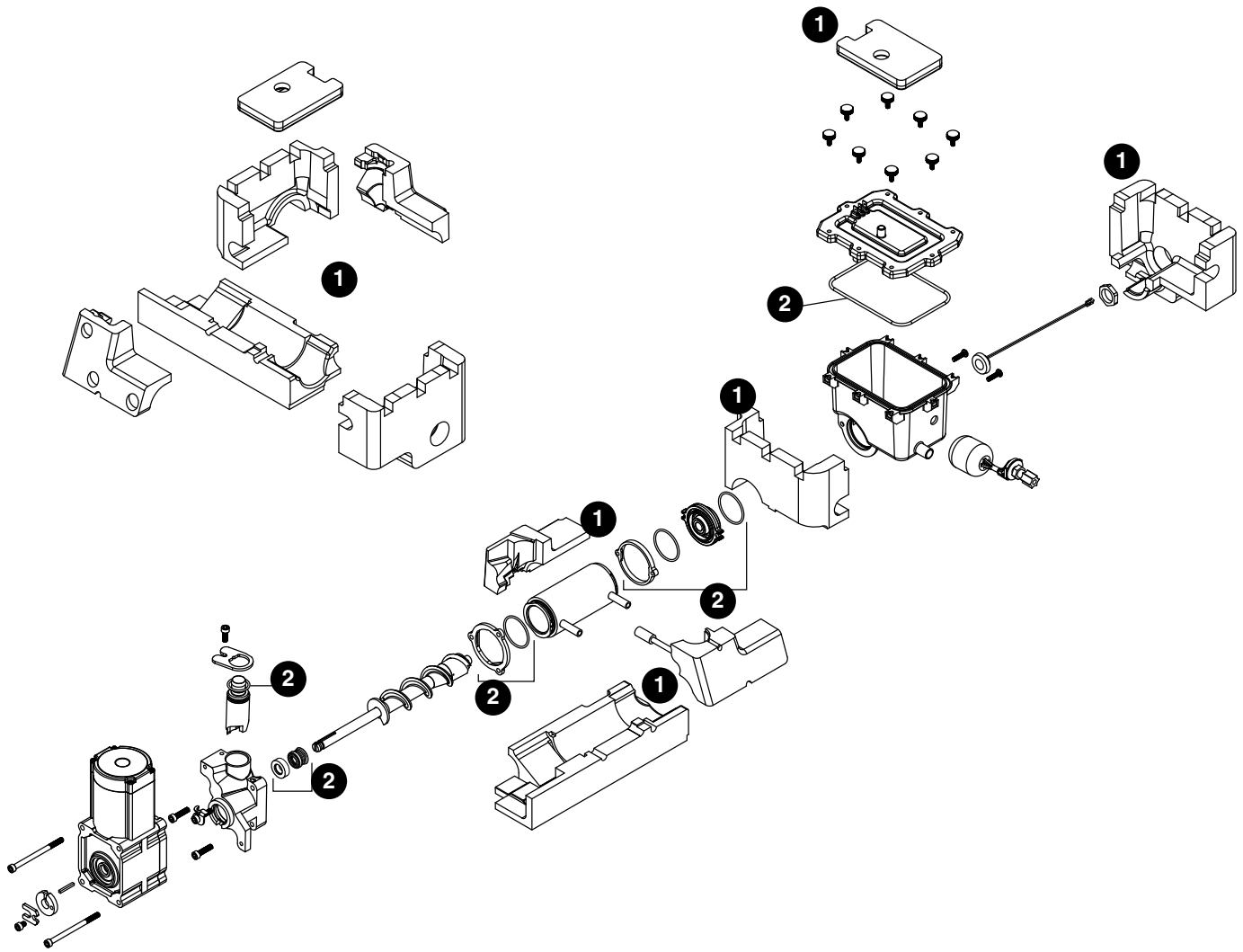

Evaporator Seal Kit

Reference #	Description	Part #
1	Insulation, Evaporator Module Kit, Champion 7/15	01536309
2	Evaporator Seal Kit	01536317

Front Panel - Champion 7

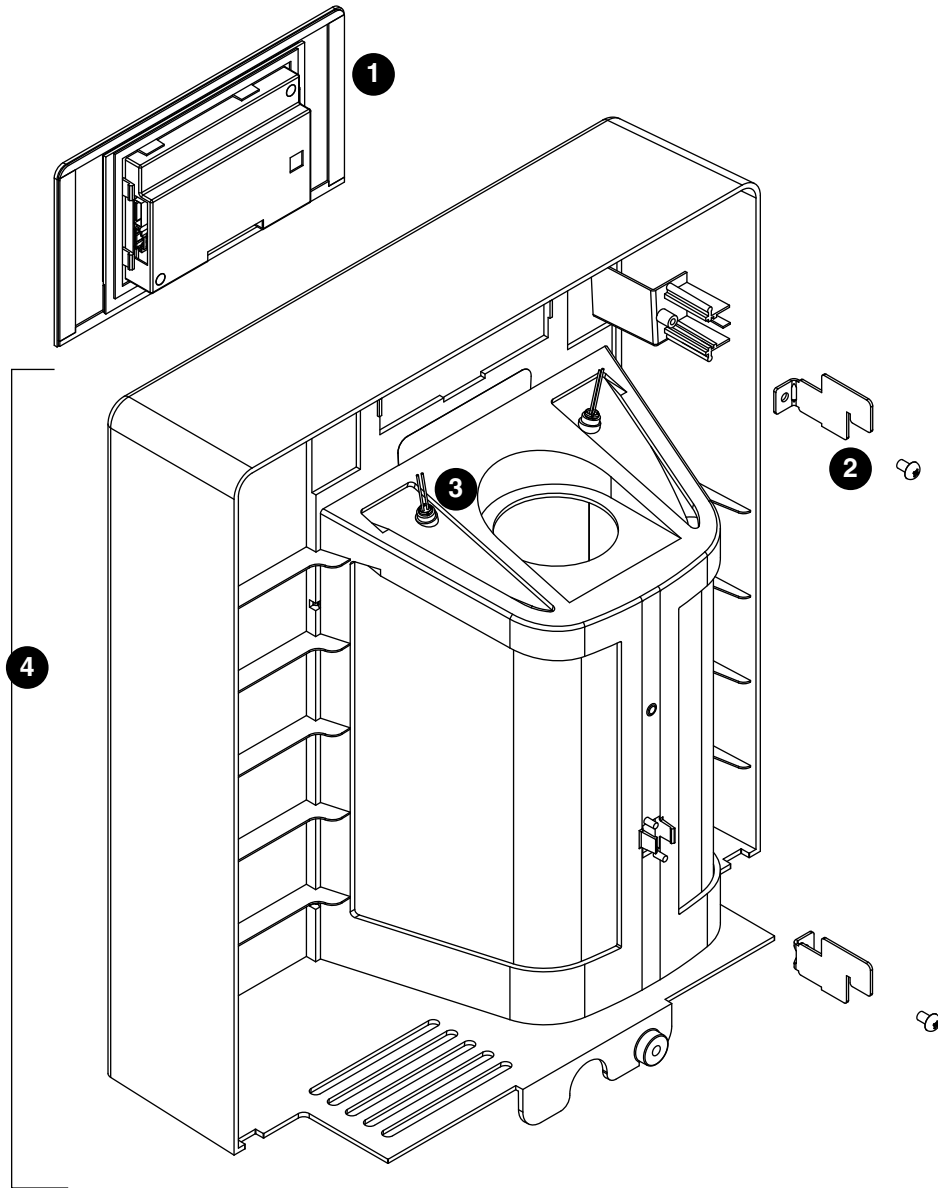

Front Panel - Champion 7

Reference #	Description	Part #
1	User Interface, Ice & Water, Champion 7/15	01535889
1	User Interface, Ice ONLY, Champion 7/15	01537059
1	User Interface, Ice & Water & Hot Tank, Champion 7/15	01537067
2	Bracket, Front Cover, Champion 7/15	01535897
3	LED Remote Dispense	01535913
4	Front Assembly, Champion 7 (User Interface not included)	01535905

Front Panel - Champion 15

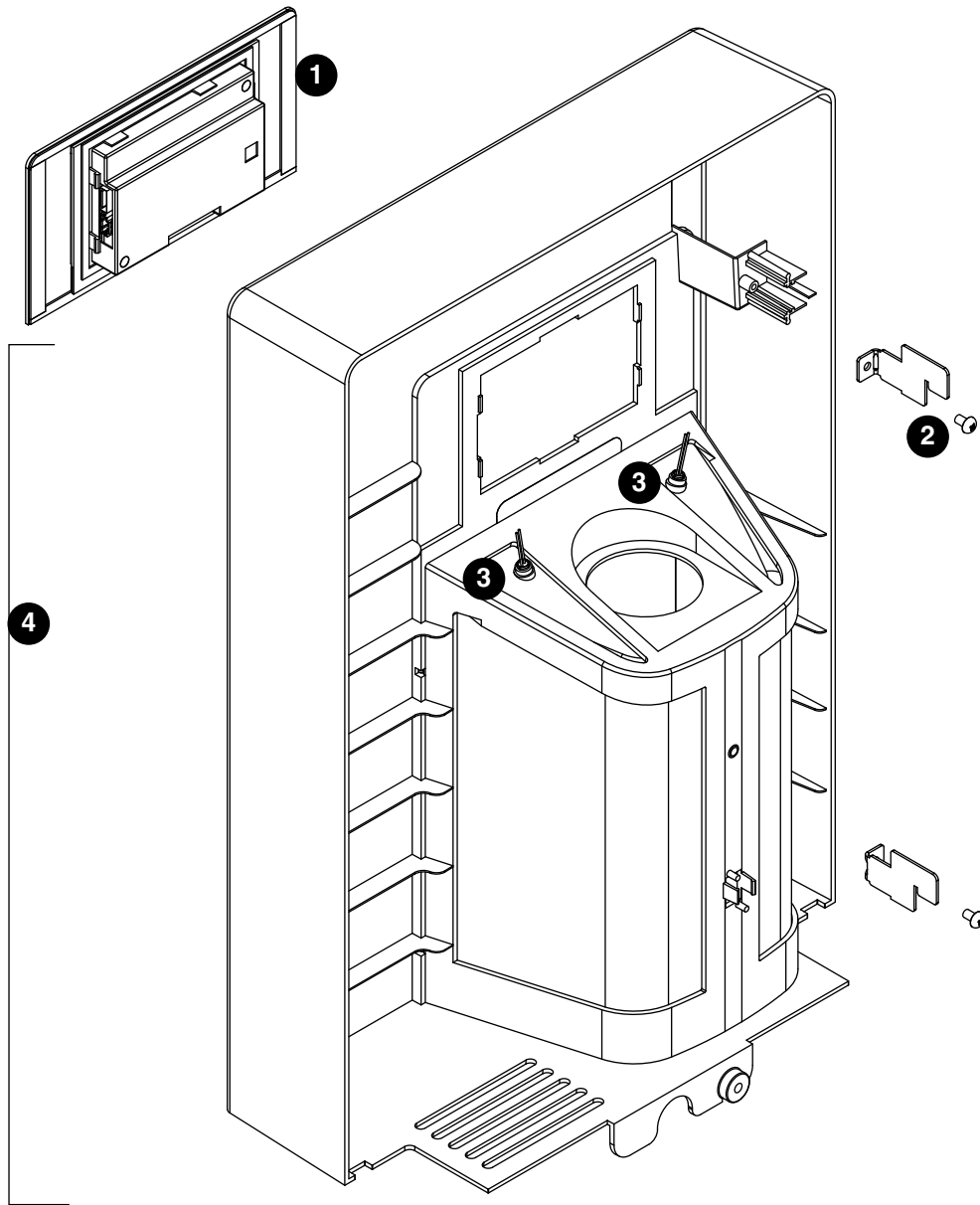

Front Panel - Champion 15

Reference #	Description	Part #
1	User Interface, Ice & Water, Champion 7/15	01535889
1	User Interface, Ice ONLY, Champion 7/15	01537059
1	User Interface, Ice & Water & Hot Tank, Champion 7/15	01537067
2	Bracket, Front Cover, Champion 7/15	01535897
3	LED Remote Dispense	01535913
4	Front Assembly, Champion 15 (User Interface not included)	01536473

Clariss Filter

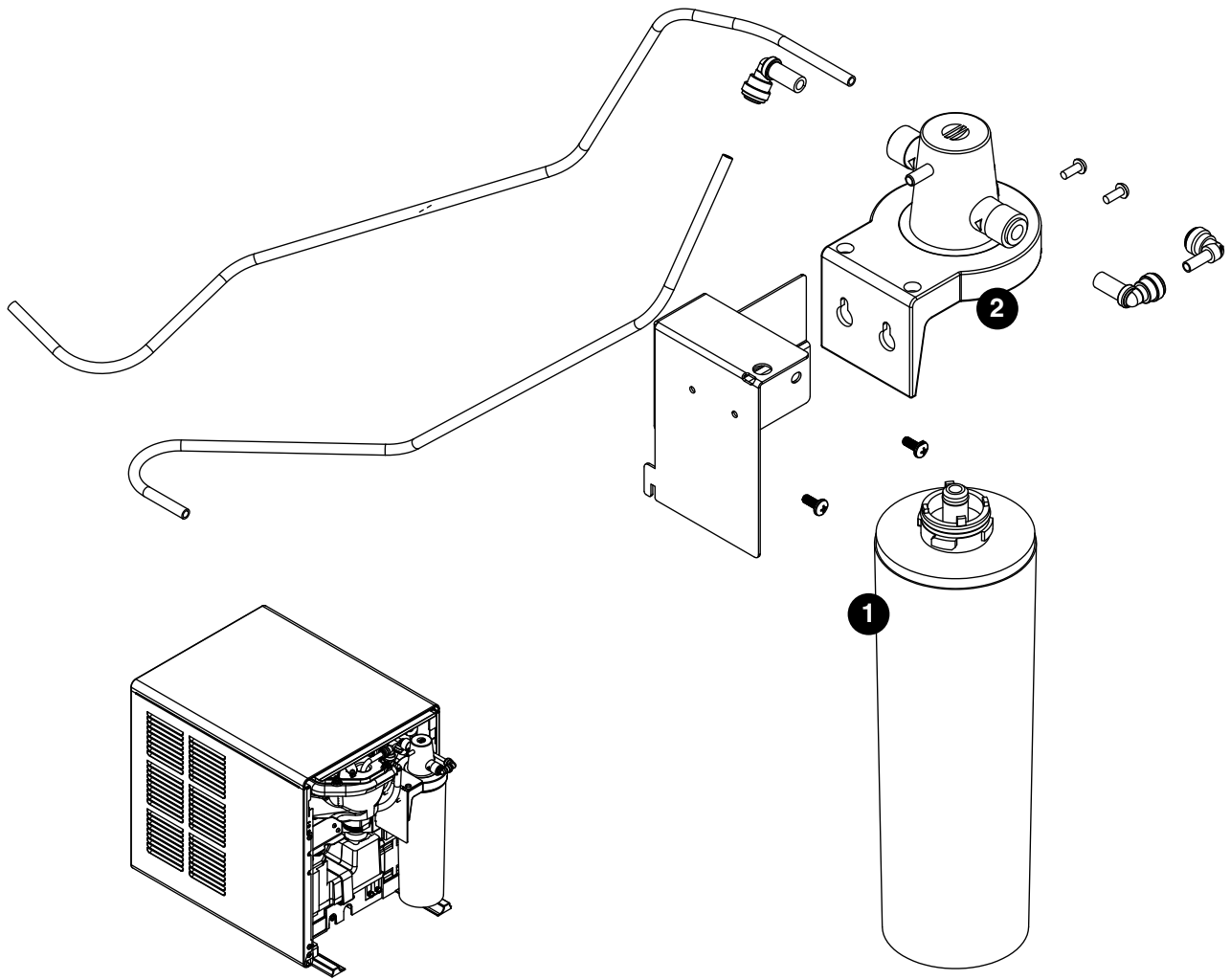

Clariss Filter

Reference #	Description	Part #
1	Filter, Clariss Filter, Champion 7/15	01548635
2	Manifold, Small Clariss Filter	01548643

Hot Tank

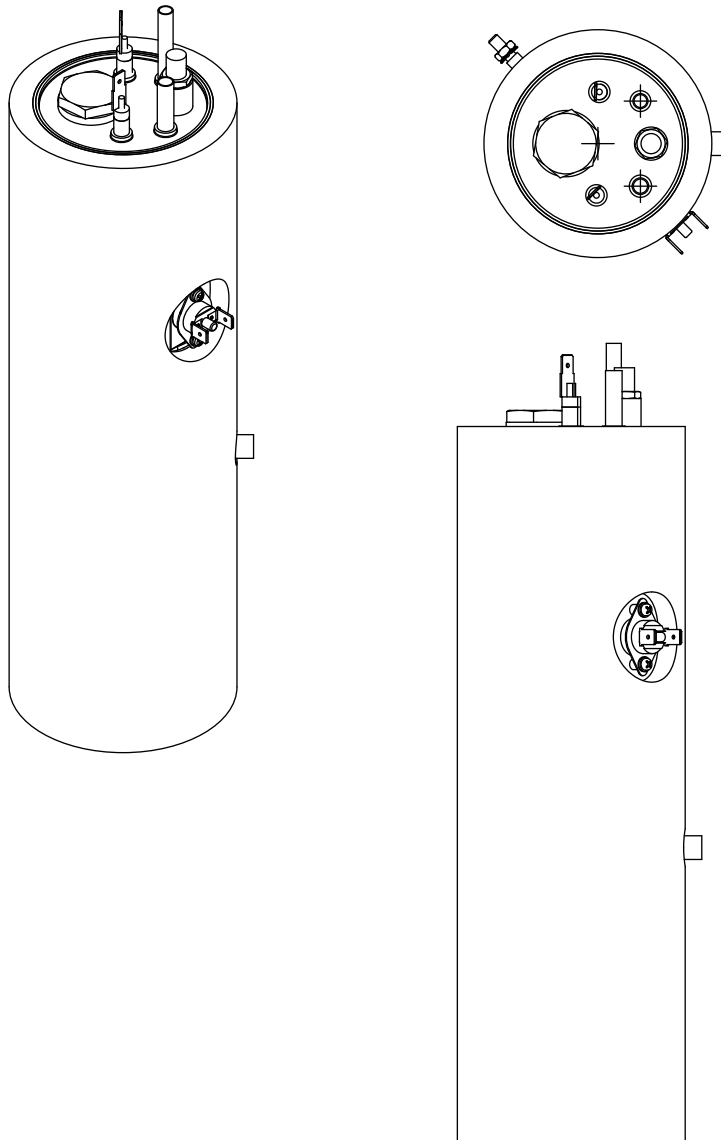

Hot Tank

Reference #	Description	Part #
—	Hot Tank	01553650
Not shown	Hot Tank Dispense Pump	01555572
Not shown	Hot Tank Water Fill Solenoid	01536176

Miscellaneous

Description	Part #
Test strip, water hardness (10)	01548460
Kay-5 sanitizer, 1 oz packets (6)	01550821
SafeCLEAN PLUS, case of 6	01149954
SafeCLEAN PLUS, case of 24	01149962
Wiring harness, low-voltage water sensor	01537257
Wiring harness, high-voltage side	01537265
Wiring harness, hot water	01537273
Cable, 4 wire	01537281
Tube, hot water silicone	01537299
Kit, compressor start components	01537307
Tubing, reservoir vent tube 13.5"	01540905
Tubing, reservoir vent tube 16.5"	01540913
Nut, reservoir lid nut	01537422

Warranty Registration and Equipment Evaluation

Thank you for purchasing Follett® equipment. Our goal is to deliver high value products and services that earn your complete satisfaction by delivering high-value products and services backed by outstanding customer and technical support.

Please review the installation instructions thoroughly. It is important that the installation be performed to factory specifications so your equipment operates at its maximum efficiency.

Follett LLC will not be liable for any consequential damages, expenses, connecting or disconnecting charges, or any losses resulting from a defect of the machine. For full warranty details, visit our website www.follettice.com/productwarranties.

Registering your equipment helps Follett track your equipment's service history should you need to contact us for technical support, and your feedback helps us improve our products and services. Please visit www.follettice.com/support to complete the Warranty Registration form.

Should you have any questions, please contact Follett's technical support group at (877) 612-5086 or (610) 252-7301 and we will be happy to assist you.

SafeCLEAN Plus is a trademark of Follett Products, LLC.

Chewblet and Follett are registered trademarks of Follett Products, LLC, registered in US.



801 Church Lane • Easton, PA 18040, USA
Toll free (877) 612-5086 • +1 (610) 252-7301
www.follettice.com

01555127R04
© Follett Products, LLC 8/24