

LEGEND	
AM AUGER MOTOR
DISP	... DISPENSE
GND	... GROUND
IM ICE MAKER
JB JUNCTION BOX
PB	... PUSH BUTTON
PL	... PLUG
QC	... QUICK CONNECT
SOL	... SOLENOID
TRAN	... TRANSFORMER
T'STAT	... THERMOSTAT
WM	... WHEEL MOTOR

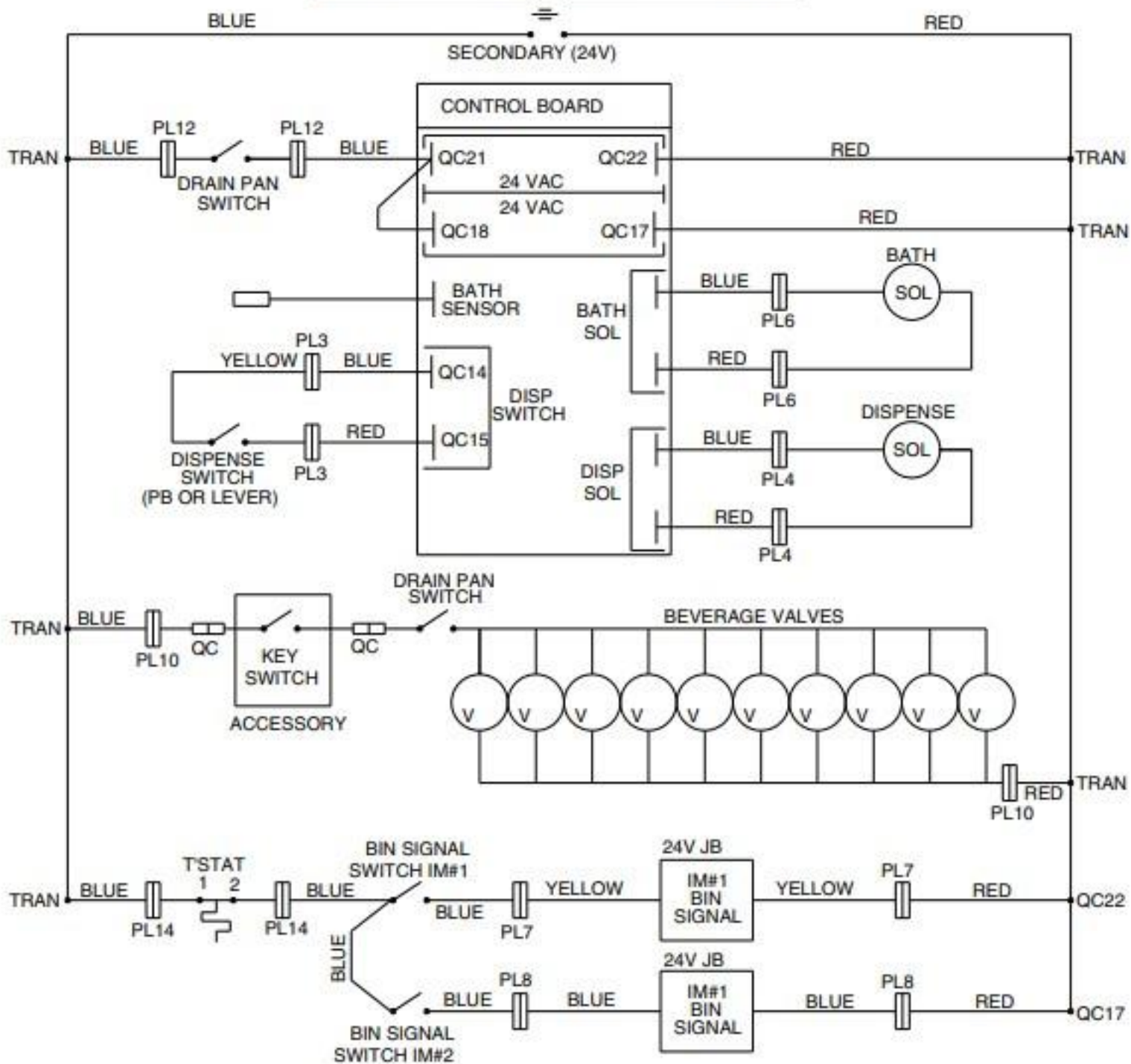

Temperature lights

Temperature lights provide information on the status of the ice-waterbath. When lighted, the following LEDs indicate:

Low LED: Bath is at optimal temperature for cold drinks.

High LED: Bath temperature is above optimal temperature. The bath will fill with ice for 15 seconds and will then stop for 75 seconds. If temperature is still too high, cycle will repeat.

Error and Low LEDs: After 15 minutes of fill cycling, bath is above 40°F (4.4°C).

Error (flashing) LED: Board not receiving signal from sensor.

