

# FACTORY PARTS CATALOG DEHUMIDIFIER

 **FRIGIDAIRE**

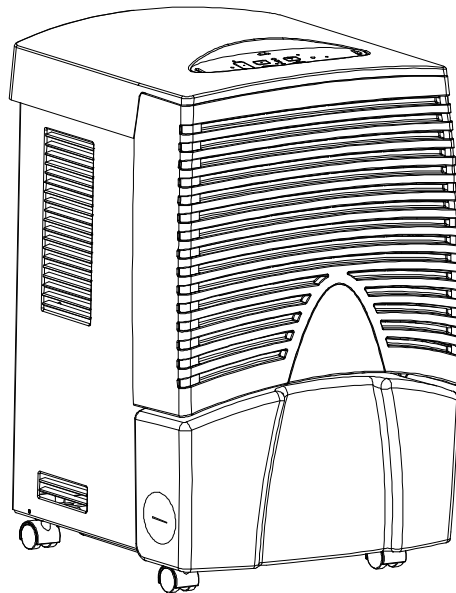

PRODUCT NO.	BASE MODEL NO.	VOLTS	PINTS / HR
FDD50J2	FDD50J	115	50

WIRING DIAGRAM # - 327160501  
OWNERS GUIDE # - 327000009

 **FRIGIDAIRE**  
**HOME PRODUCTS**  
P.O. Box 212378  
Augusta, GA 30917

Publication No.  
5995344685  
000413  
-EN/SERVICE /REP  
345

DEHUMIDIFIER

Model No.  
FDD50J2

©2000 White Consolidated Industries, Inc.  
All rights reserved

# WRAPPER

---

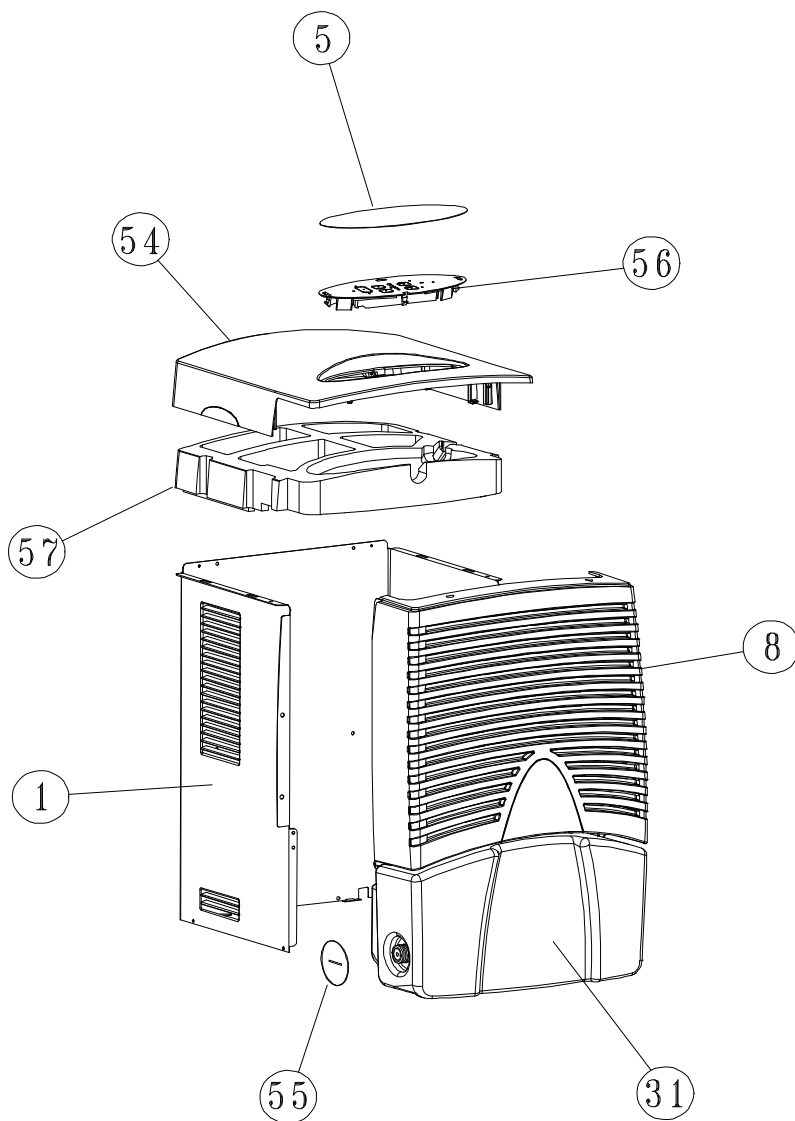

## WRAPPER

---

POS. NO.	PART NO.	DESCRIPTION
1	327660002	Cabinet
5	327360501	Overlay
8	327661501	Front
31	<a href="#">327661902</a>	Bucket
54	327661201	Top Cap
55	327160101	Hose Cap
56	327360302	Control Panel
57	327660402	Scroll Cap
*	327362201	Control Humidity
*	327161201	Switch
*	327161101	Push Button
*	327160001	Indicator Light
*	309307013	Control Knob
*	327000009	Owners Manual

# = Functional Parts  
\* = Non-illustrated Parts

### SYSTEM PARTS

---

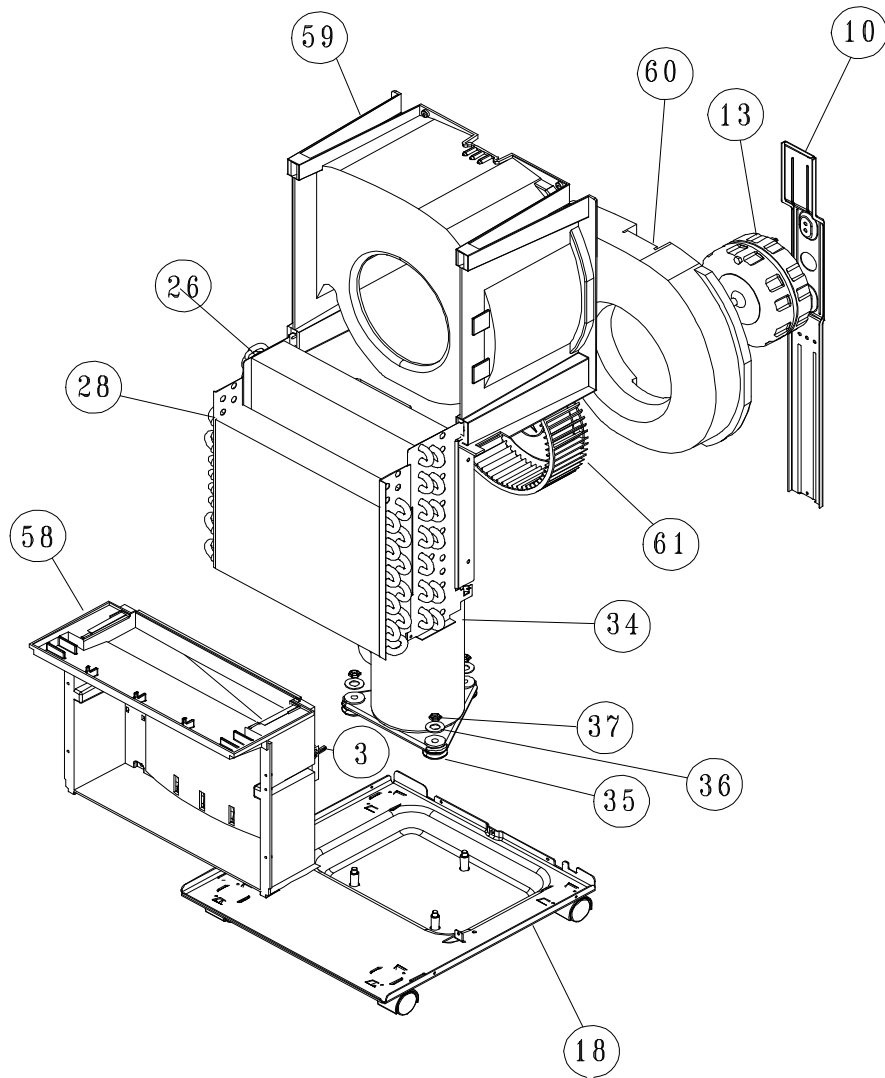

## SYSTEM PARTS

---

POS. NO.	PART NO.	DESCRIPTION
3	5308016437	Switch-auto shut off,bucket
10	327362101	Bracket, motor
13	327650407	Motor-fan, 2Speed
18	327660308	Base plate, with casters
26	327361001	Condenser
28	327361401	Evaporator
34	5304416101	Compressor
35	327160902	Grommet
36	327161503	Washer-compressor
37	327161502	Nut-compressor
58	327660501	Coil support/Drip tray
59	327660201	Scroll
60	327362001	Scroll back
61	327360001	Blower wheel
*	08007481	Nut-Motor Mounting
*	327161302	Clamp-Blower wheel
*	5304416308	Caster
*	5304410096	Capillary tube
*	327160709	Harness-compressor
*	5304416103	Capacitor
*	5304416102	Overload
*	5304416417	Cover-terminal
*	5303291330	Gasket-cover terminal
*	5303294292	Nut-Cover terminal
*	5304416426	Cord power

# = Functional Parts  
\* = Non-illustrated Parts



**NOTES**

---