

FACTORY PARTS CATALOG DEHUMIDIFIER

 **FRIGIDAIRE**

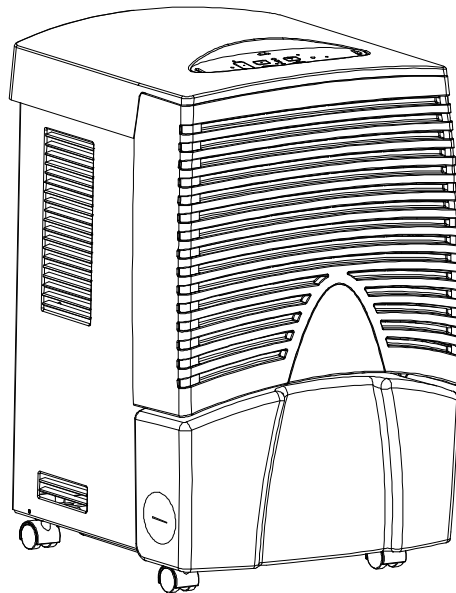

PRODUCT NO.	BASE MODEL NO.	VOLTS	PINTS / HR
FDH30J2	FDH30J	115	30

WIRING DIAGRAM # - 327160504
OWNERS GUIDE # - 327000009

 **FRIGIDAIRE**
HOME PRODUCTS
P.O. Box 212378
Augusta, GA 30917

Publication No.
5995343802
000413
-EN/SERVICE /REP
345

DEHUMIDIFIER

Model No.
FDH30J2

©2000 White Consolidated Industries, Inc.
All rights reserved

WRAPPER

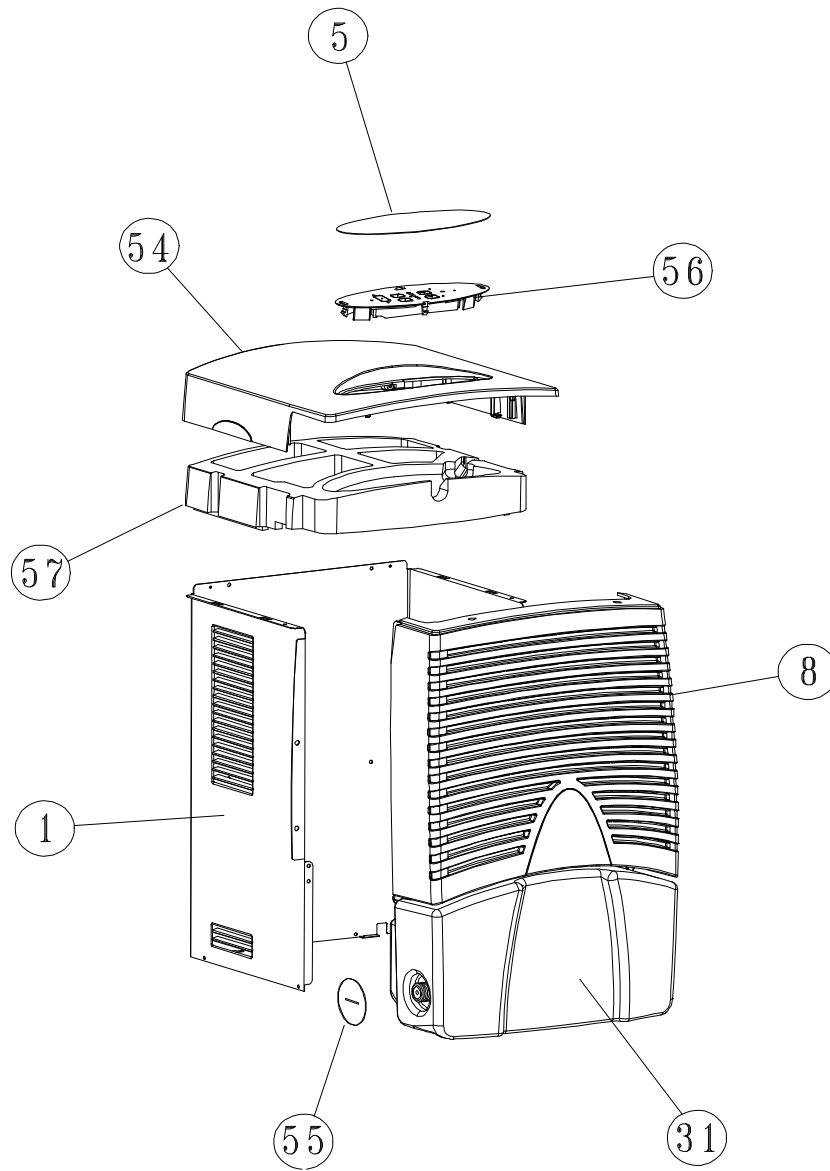

WRAPPER

POS. NO.	PART NO.	DESCRIPTION
1	327660002	Cabinet
5	327360502	Overlay
8	327661501	Front
31	327661902	Bucket
54	327661201	Top Cap
55	327160101	Hose Cap
56	327360301	Control Panel
57	327660402	Scroll Cap
*	327160001	Indicator Light
*	309307013	Control Knob
*	327000009	Owners Manual

= Functional Parts
* = Non-illustrated Parts

SYSTEM PARTS

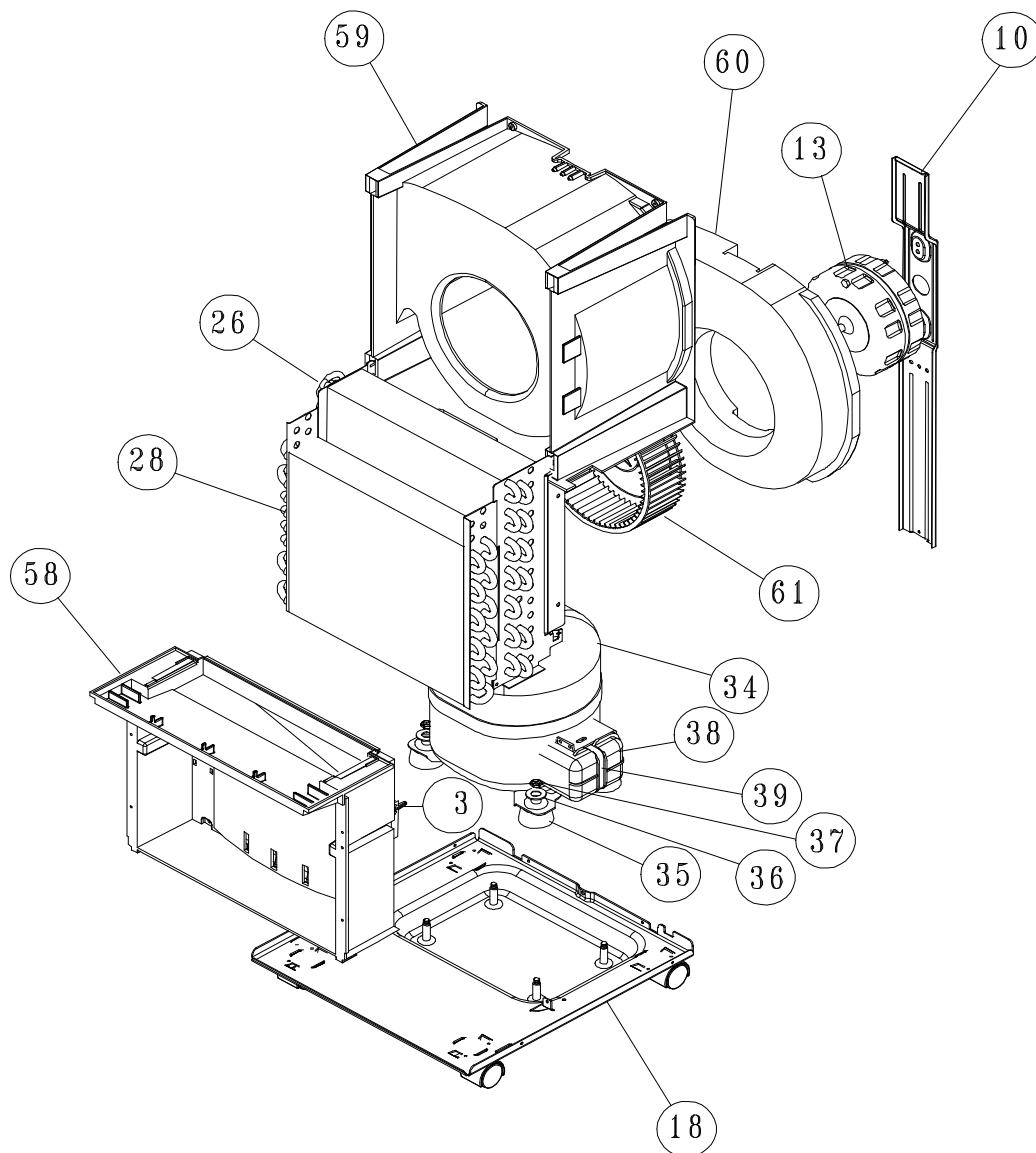

SYSTEM PARTS

POS. NO.	PART NO.	DESCRIPTION
3	5308016437	Switch-auto shut off,bucket
10	327362101	Bracket, motor
13	327650409	Motor-fan, 1Speed
18	327660303	Base plate, with casters
26	327651601	Condenser & Evaporator in one
28	327651601	Evaporator & Condenser in one
34	327603702	Compressor
35	5303286606	Grommet
36	5303002664	Washer-compressor
37	08006948	Nut-compressor
58	327660501	Coil support/Drip tray
59	327660201	Scroll
60	327362001	Scroll back
61	327360001	Blower wheel
*	08007481	Nut-Motor Mounting
*	327161302	Clamp-Blower wheel
*	5304416308	Caster
*	5304410096	Capillary tube
*	327160704	Harness-compressor
*	5304416099	Overload
*	327101603	Cover-terminal
*	327101503	Starting Relay-MTRP0051-02
*	5304416438	Cord power

= Functional Parts
* = Non-illustrated Parts

NOTES
