

INSTALLER'S GUIDE - DOCUMENT PART NUMBER 19011996 REV B, 02-14-19

SMARTWARES RAIL KITS

MODEL #:	Long Smartwares Rail	Short Smartwares Rail
PART #:	27807541, 27807543	27807542, 27807544

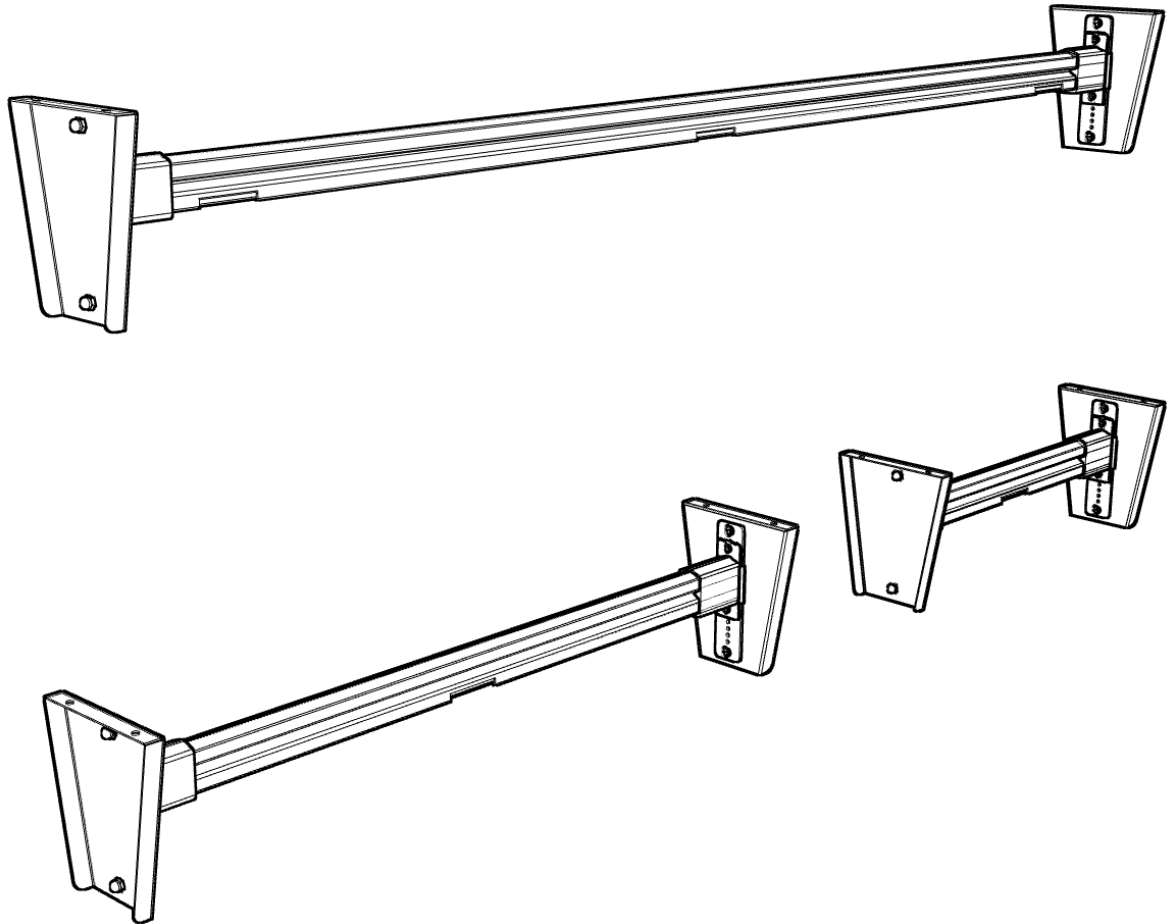

TOOLS AND SUPPLIES NEEDED (NOT INCLUDED)

Screw Driver Set	Hex Driver
1/8" & 3/32" Drill Bits	Drill

WARNING!

IMPROPER INSTALLATION, ADJUSTMENT, ALTERATION, MAINTENANCE, OR SERVICE COULD CAUSE PROPERTY DAMAGE, INJURY, OR DEATH. READ THESE INSTRUCTIONS, AND ALL OTHER DOCUMENTS THAT SHIPPED WITH THE EQUIPMENT FROM THE FACTORY WHEN NEW, COMPLETELY BEFORE INSTALLING OR OPERATING. SAVE ALL INSTRUCTIONS FOR FUTURE REFERENCE.

IMPORTANT SAFETY INFORMATION

EXPLANATION OF SAFETY AND NOTICE SYMBOLS

- ▲ DANGER** DANGER indicates a hazardous situation which, if not avoided, **WILL** result in death or serious injury.
- ▲ WARNING** WARNING indicates a hazardous situation which, if not avoided, **COULD** result in death or serious injury.
- ▲ CAUTION** CAUTION indicates a hazardous situation which, if not avoided, could result in minor or moderate injury.
- NOTICE** NOTICE is used to address practices not related to physical injury.

READ AND SAVE THESE INSTRUCTIONS

▲ WARNING

Unauthorized modifications or repairs pose a hazard in the form of an improperly functioning unit.

- ONLY for commercial use.
- NEVER make ANY modifications to the unit that are not authorized by documentation provided by *Franke*.
- NEVER remove any labels from the unit.
- ALWAYS replace ANY labels that have been removed or damaged IMMEDIATELY.
- ONLY use original equipment manufacturer (OEM) parts when service, maintenance, or installation work is performed.
- NEVER operate with factory installed parts or components removed.
- NEVER use for other than intended use.

Failure to follow these safety instructions COULD result in death or serious injury.

These instructions are intended for qualified persons ONLY. Use by others creates an unsafe condition.

- ONLY persons who are certified technicians or trades persons with the requisite knowledge, skills, ability, and training, MUST perform service or installation work.
- ALWAYS keep out of the reach of children.
- ONLY allow access to unit by trained personnel who have read this manual.

Failure to follow these safety instructions COULD result in death or serious injury, as well as property damage or void of warranty.

▲ CAUTION

Lifting and transporting heavy objects poses a hazard of injury.

- NEVER lift or move equipment without proper tools or assistance.

Failure to follow these safety instructions COULD result in minor to moderate injury.

Steel surfaces may have sharp edges which pose a hazard of injury

- ALWAYS wear appropriate personal protective equipment (PPE) when moving or handling equipment.

Failure to follow these safety instructions COULD result in minor to moderate injury.

NOTICE

NEVER use inappropriate tools, processes, or procedures. Damage to components of unit can occur.

- Follow these instructions EXACTLY to avoid property damage or void of warranty.
-

NEVER discard any loose parts received with unit. They may be required for proper and safe installation and operation.

LONG SMARTWARES RAIL

SECTION 1 – KIT CONTENTS

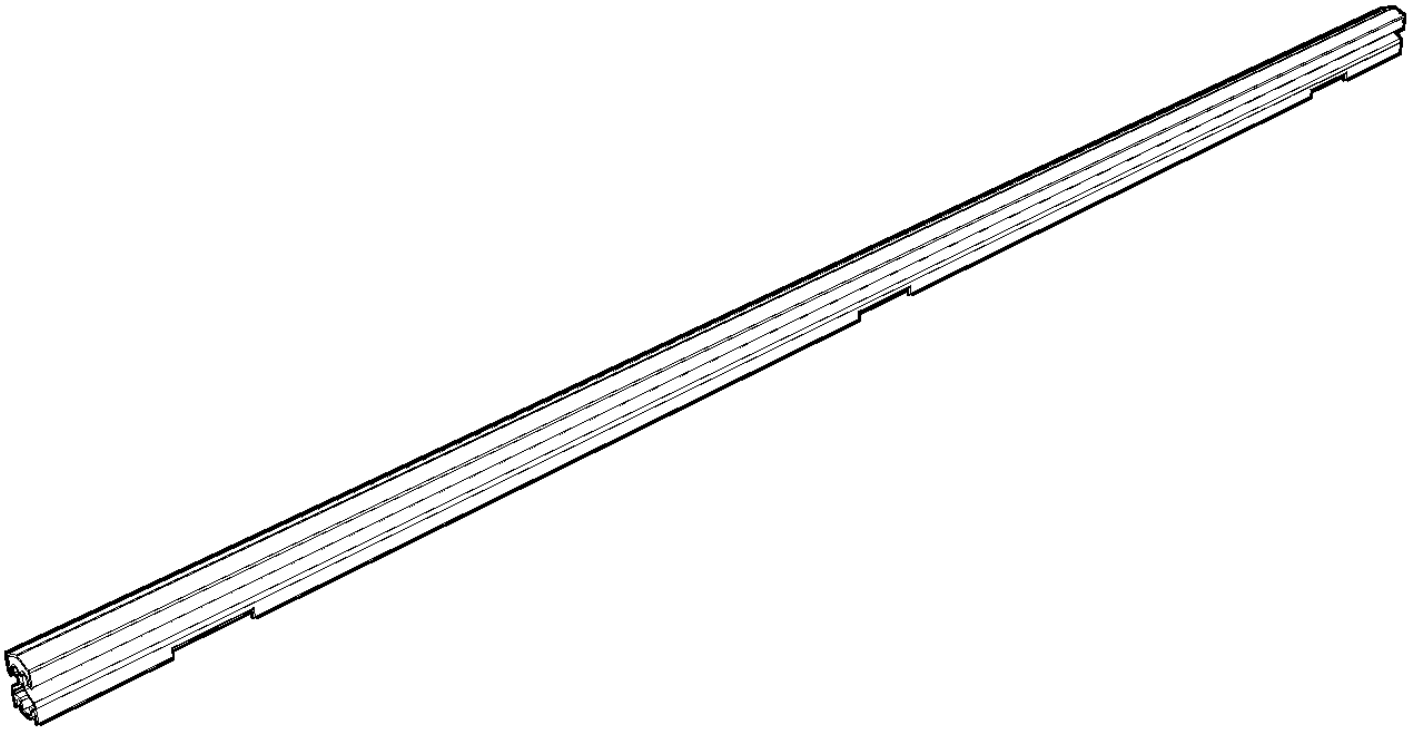

60" SMARTWARES RAIL

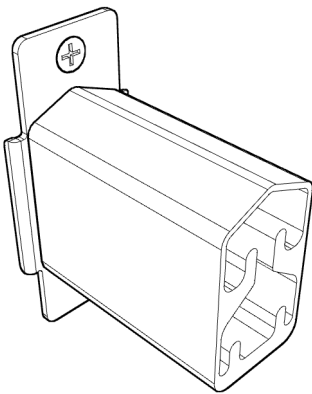

MOUNTING BRACKET (x2)

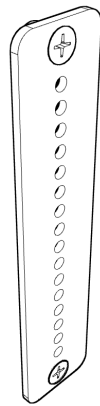

ADAPTER BRACKET (x2)

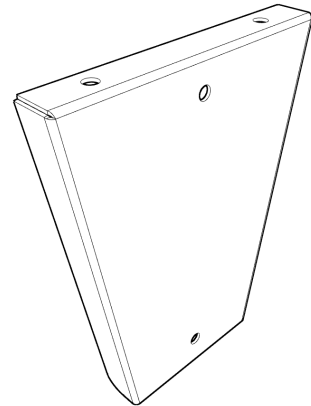

UNDERMOUNT BRACKET (x2)

HARDWARE KIT

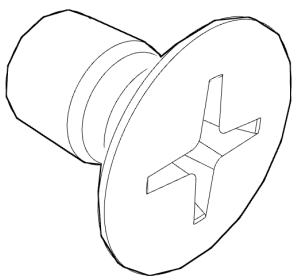

SCREW, M6 X 10 (x4)

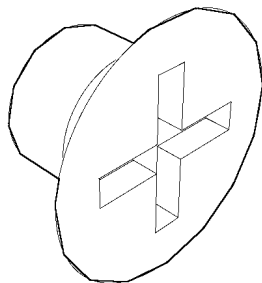

SCREW, M4 X 8 (x4)

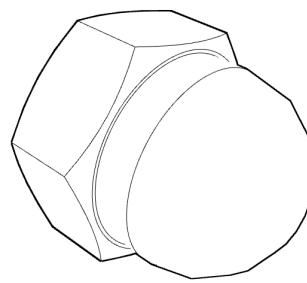

ACORN NUT, M6 (x4)

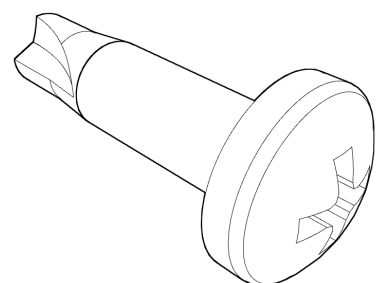

SELF-TAPPING SCREW (x4)

LONG SMARTWARES RAIL

SECTION 2 – INSTALLATION WITH SIDE ADAPTOR BRACKETS

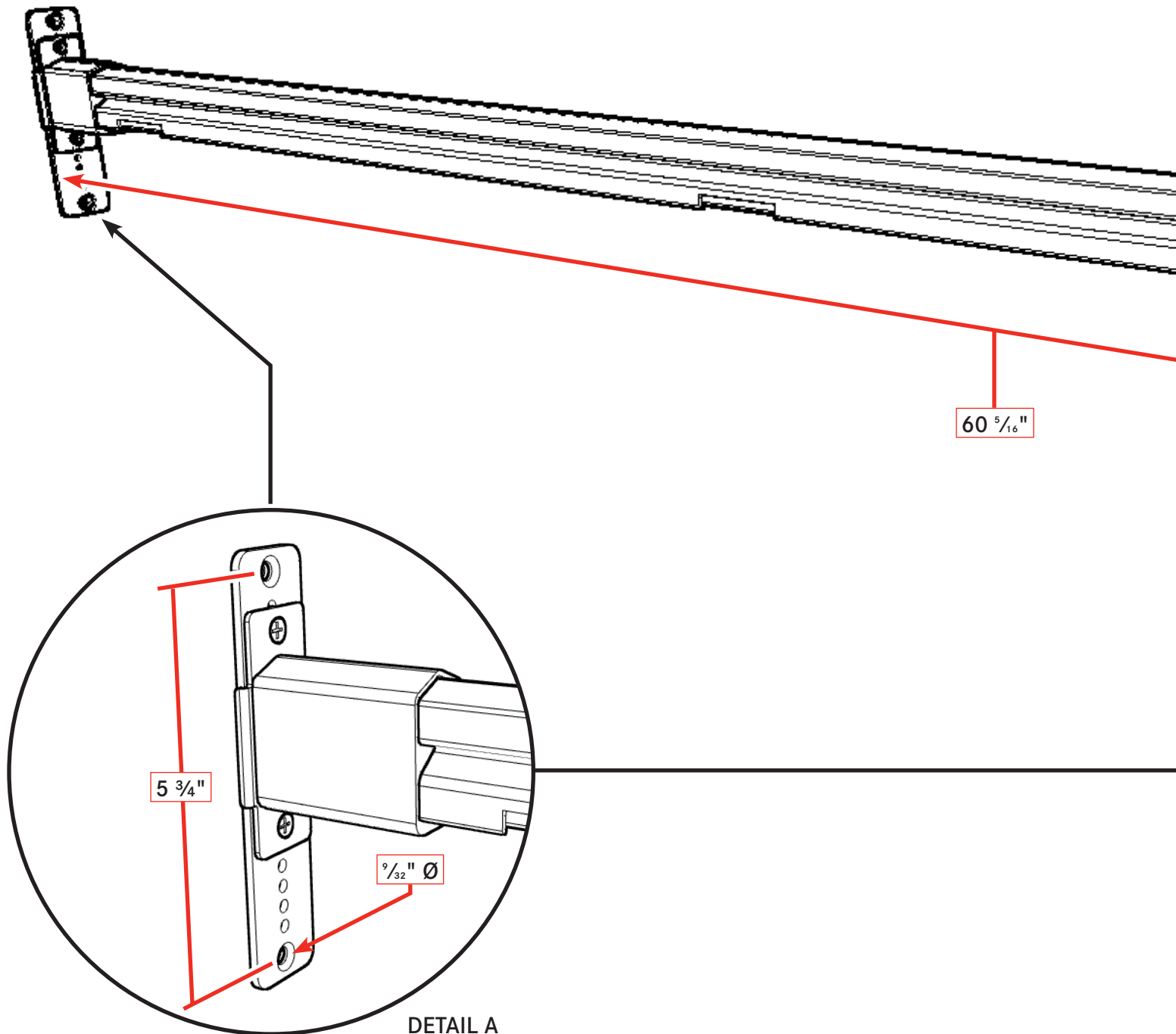

LONG SMARTWARES RAIL

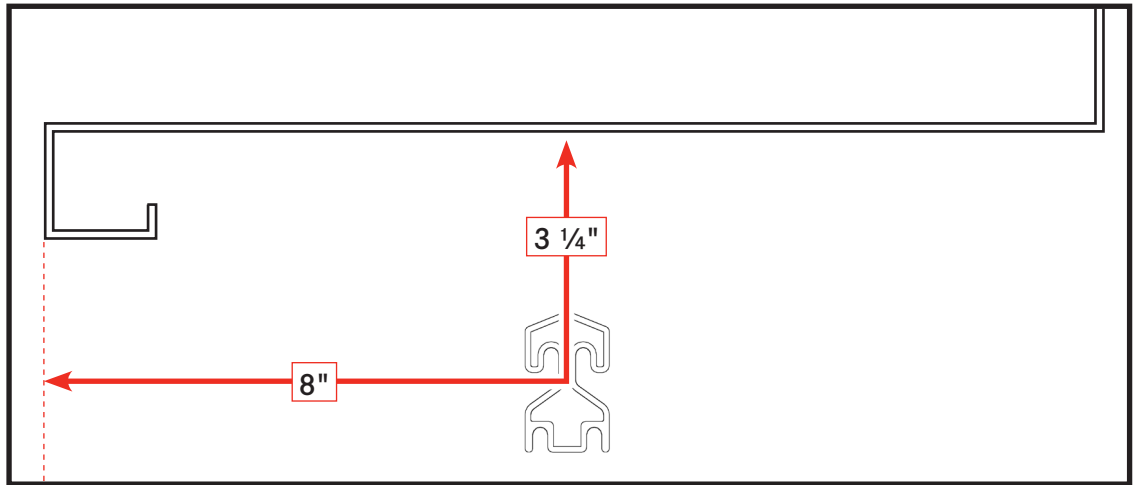

DETAIL B

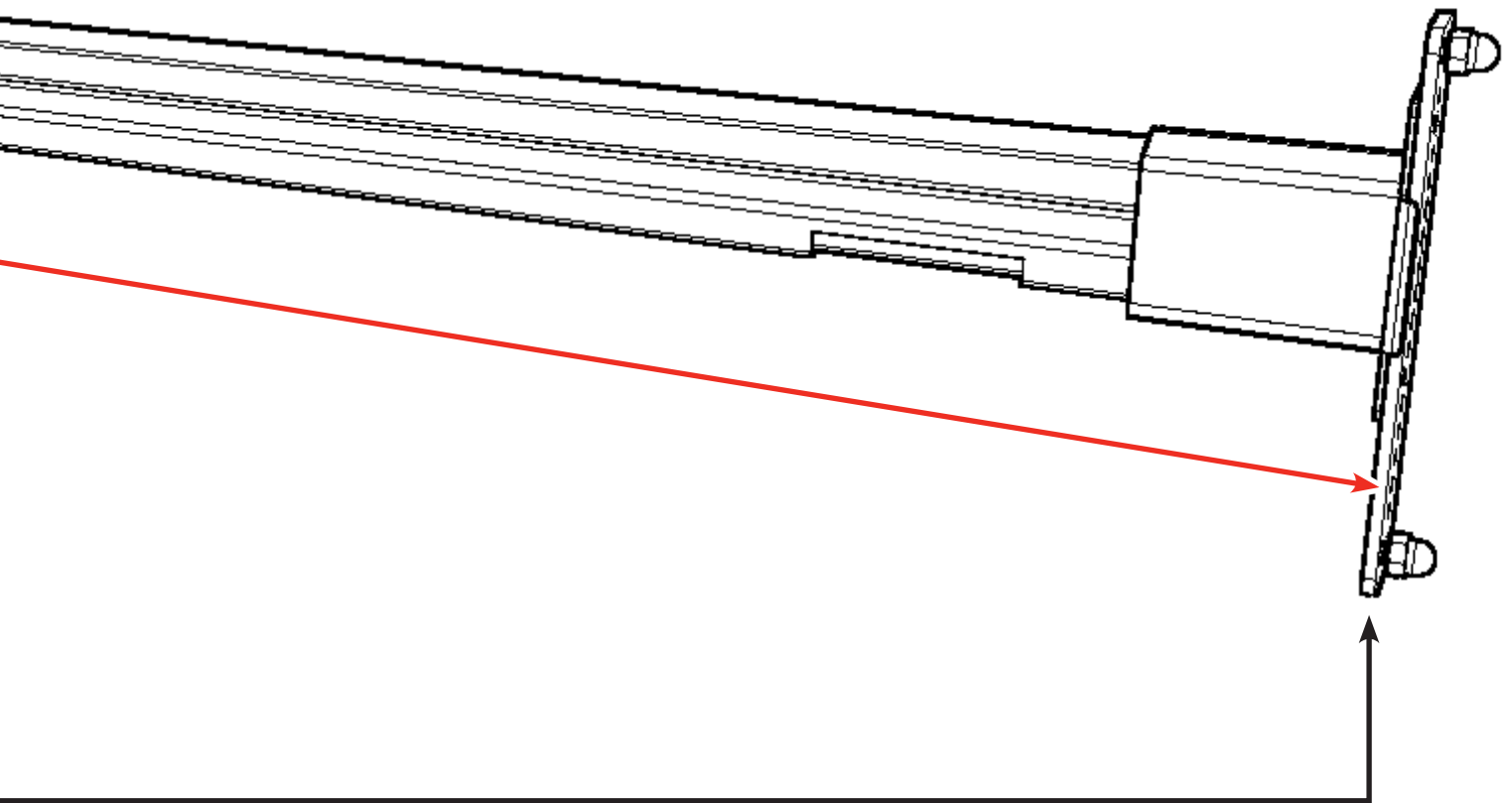

LONG SMARTWARES RAIL

SECTION 3 - INSTALLATION WITH ONE UNDERMOUNT BRACKET

TO UNDERSHELF BOTTOM

$5/8''$

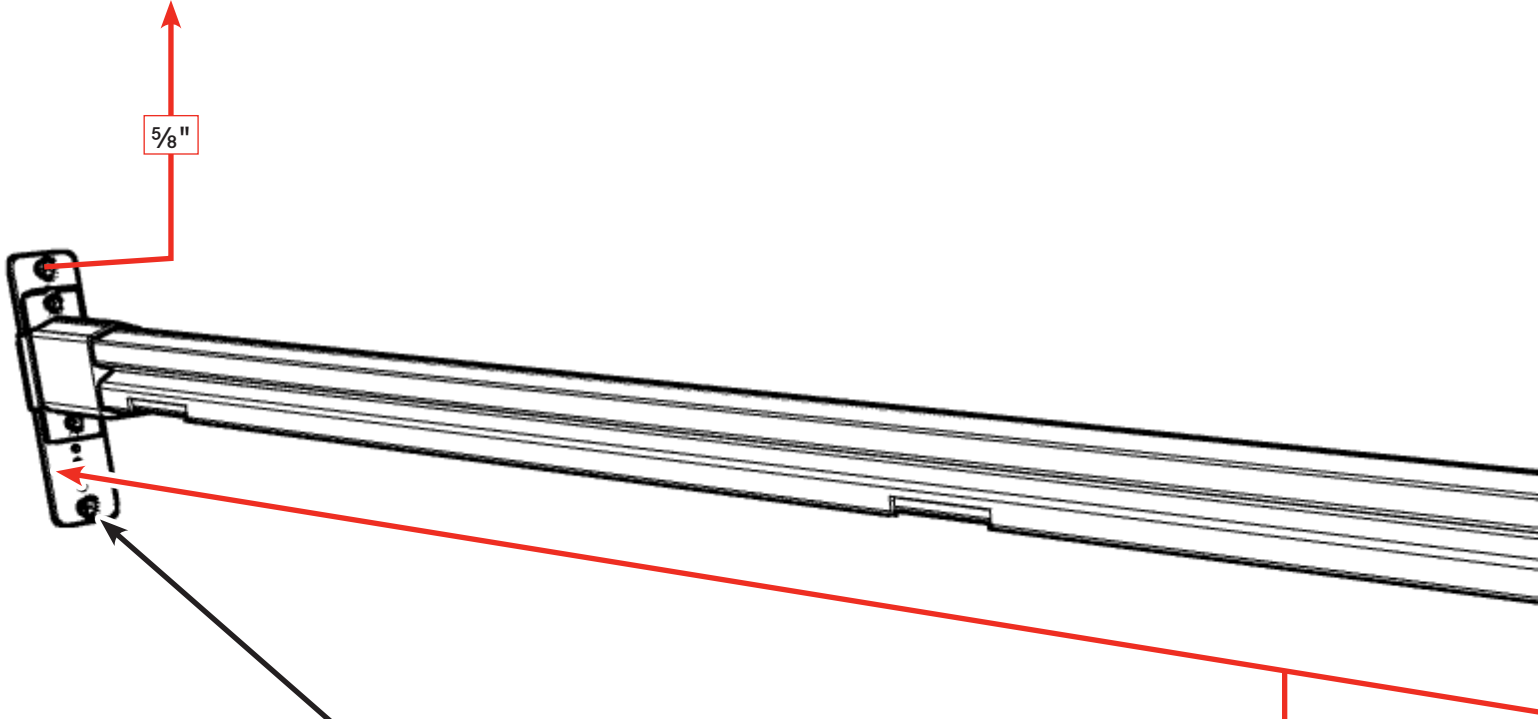

$61\ 1/8''$

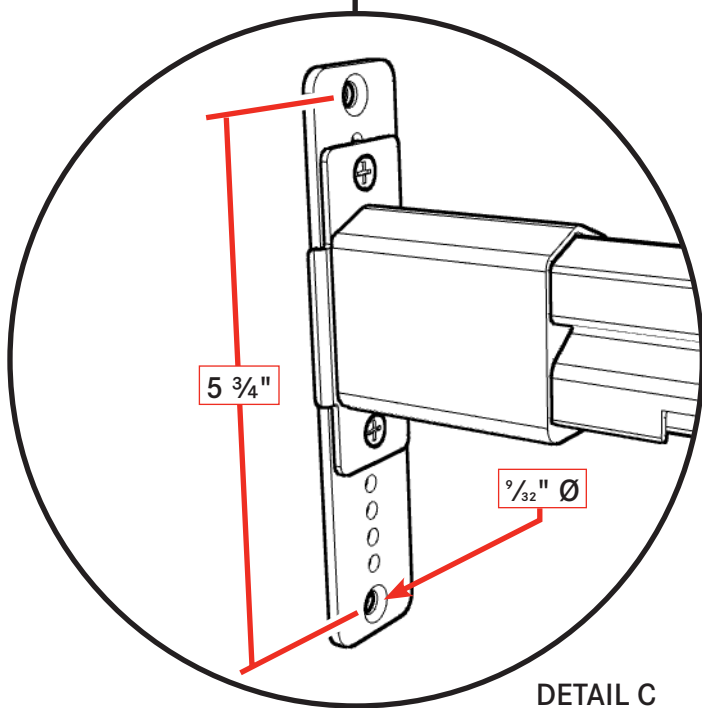

DETAIL C

LONG SMARTWARES RAIL

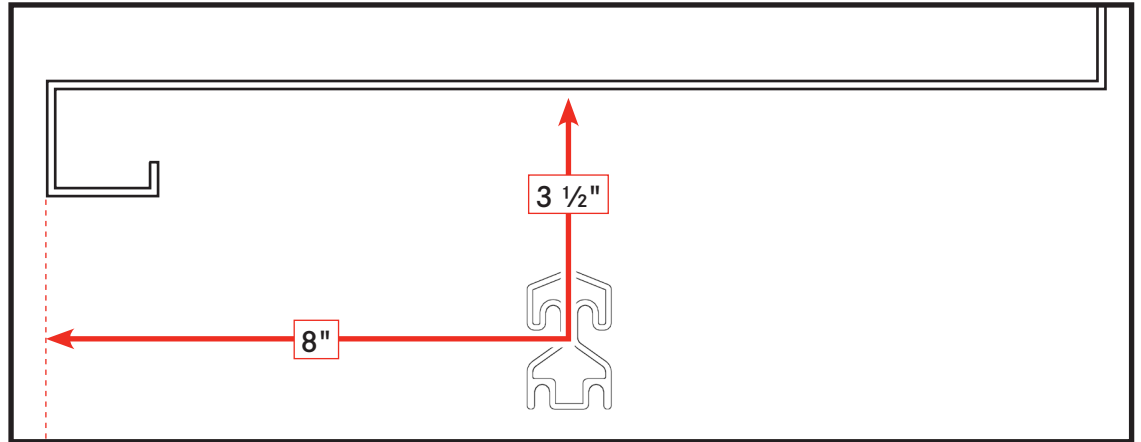

DETAIL D

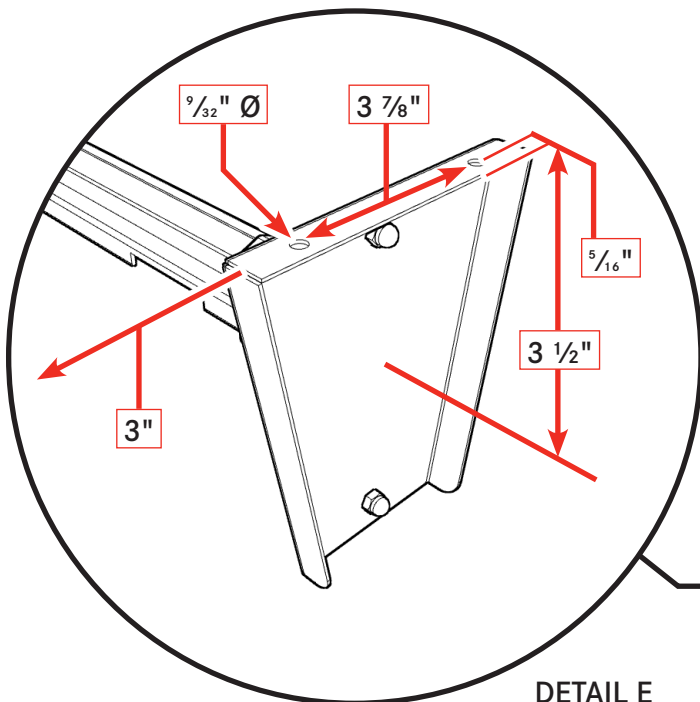
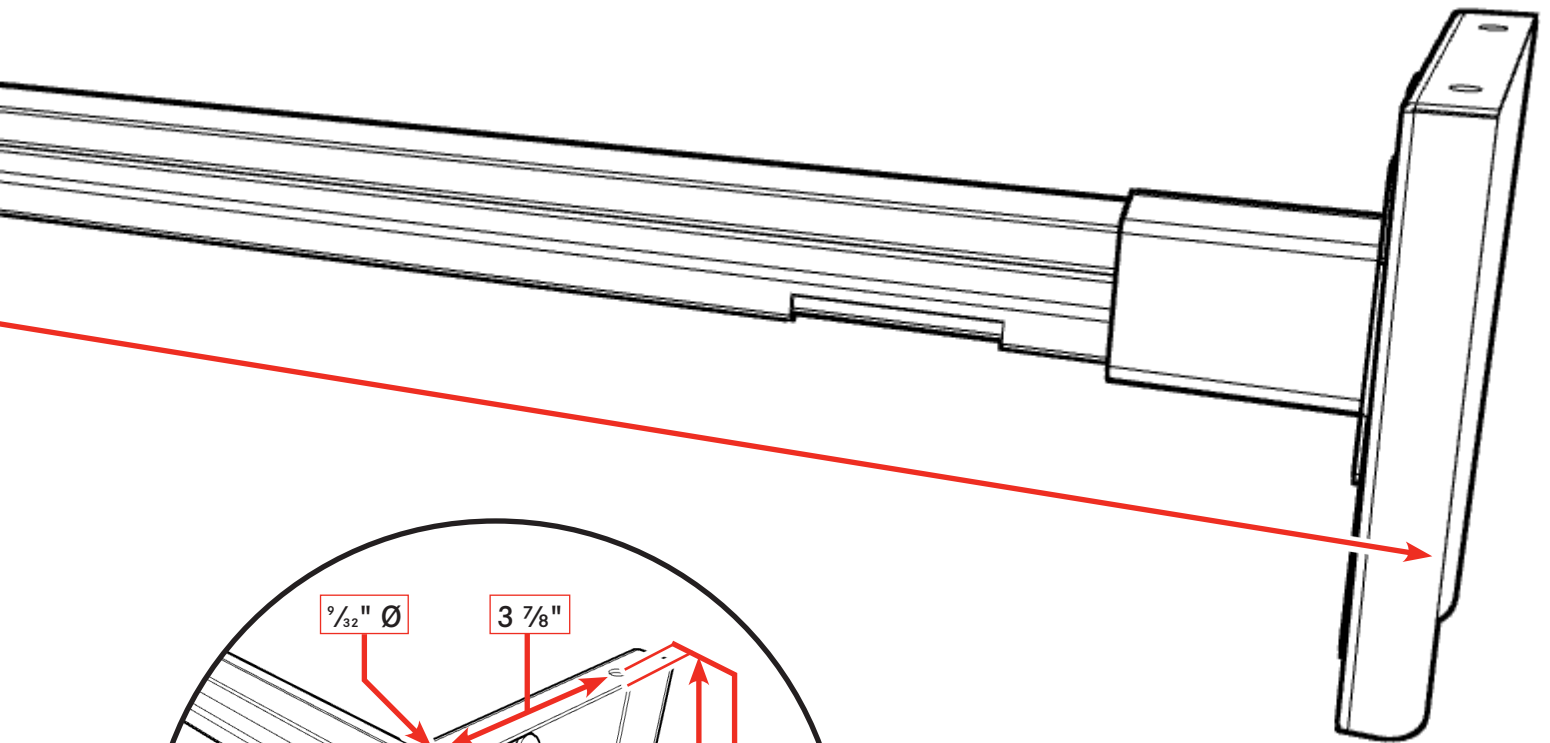

DETAIL E

LONG SMARTWARES RAIL

SECTION 4 - INSTALLATION WITH TWO UNDERMOUNT BRACKETS

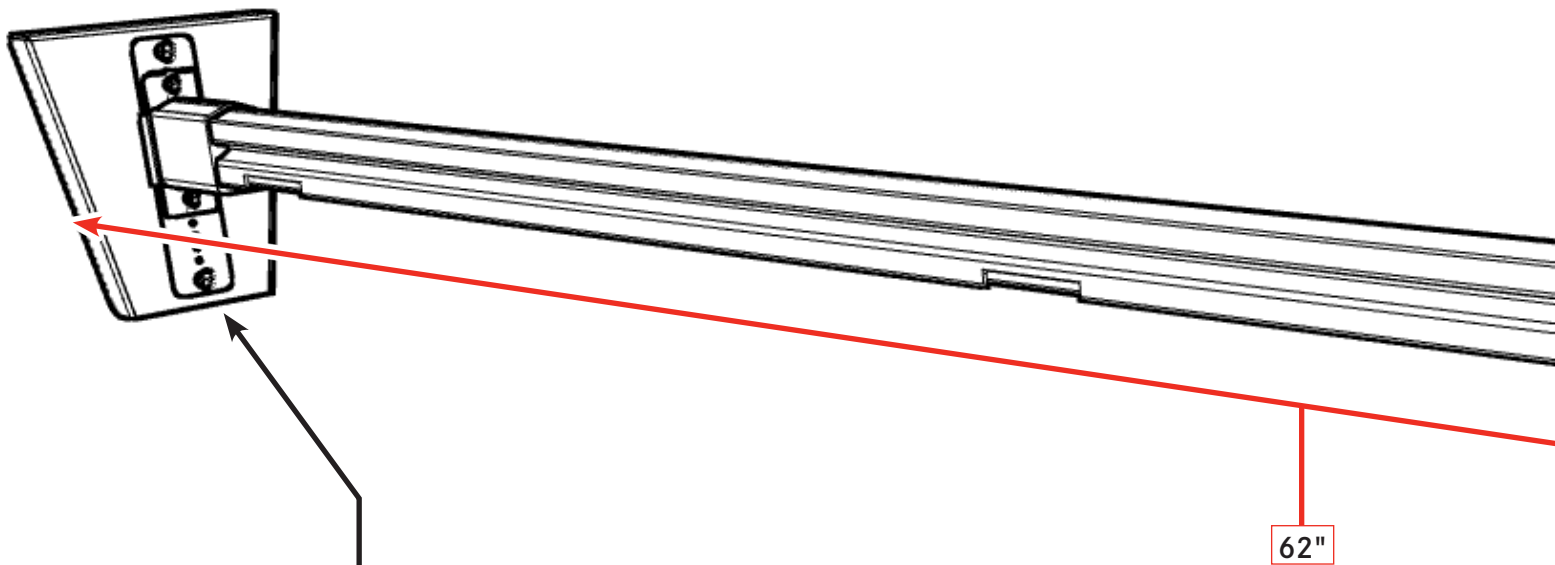

62"

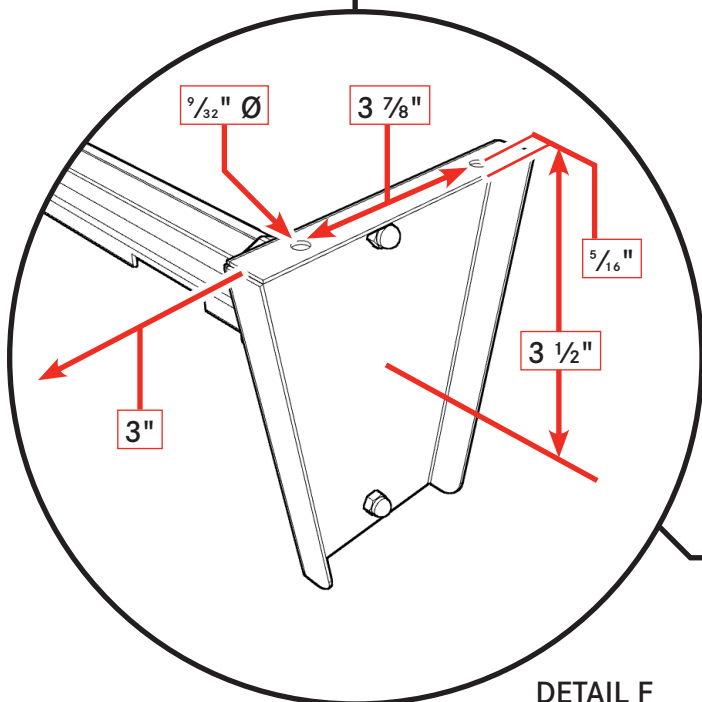

DETAIL F

LONG SMARTWARES RAIL

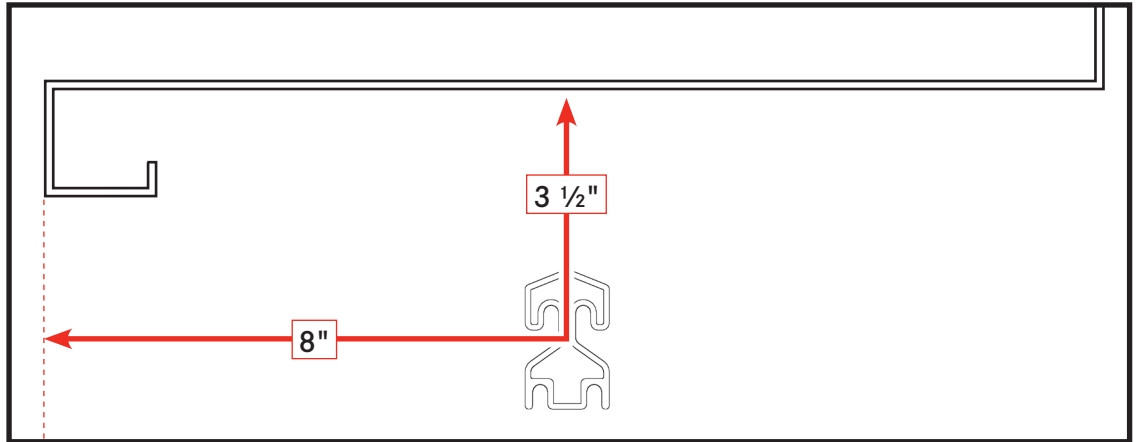

DETAIL G

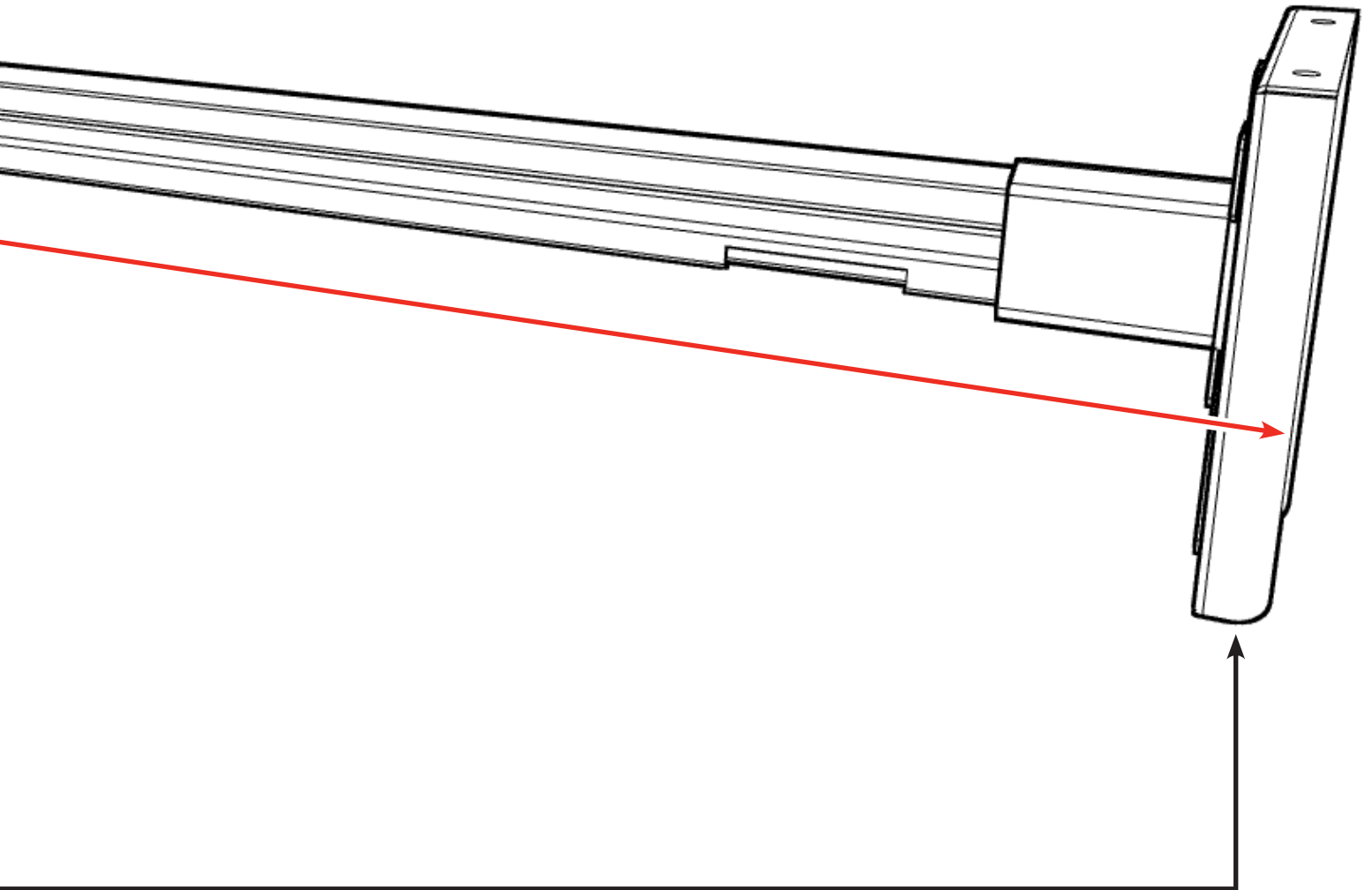

SHORT LINEAR SMARTWARES RAIL

SECTION 1 – KIT CONTENTS

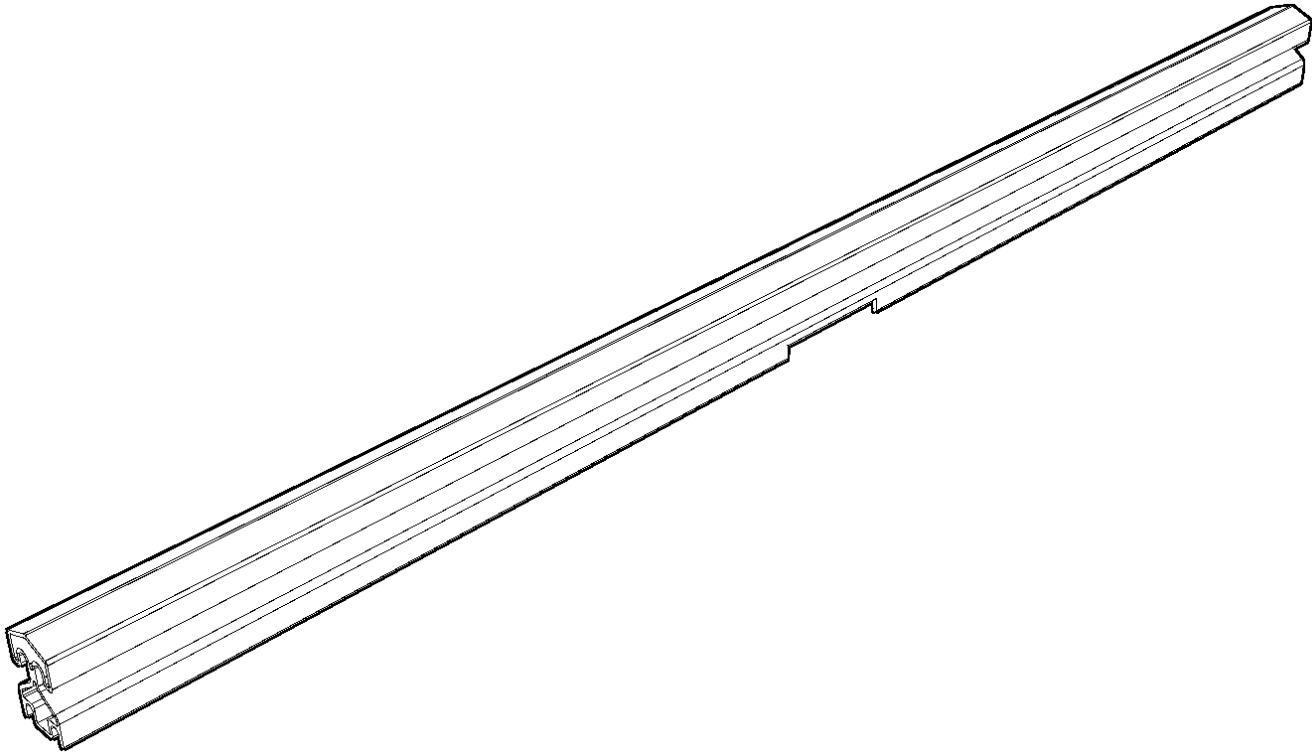

34-1/4" SMARTWARES RAIL

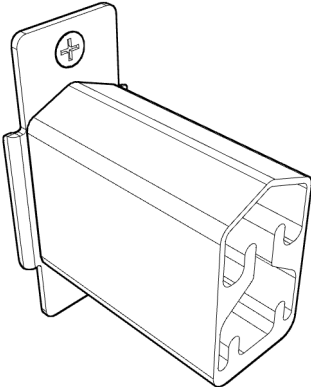

MOUNTING BRACKET (x2)

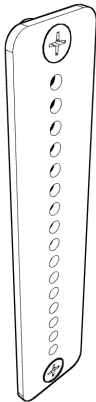

ADAPTER BRACKET (x2)

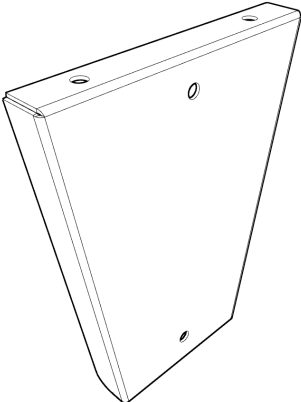

UNDERMOUNT BRACKET (x2)

HARDWARE KIT

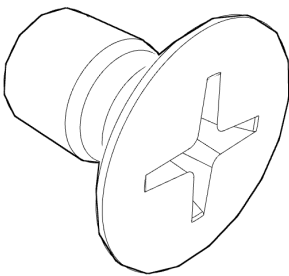

SCREW, M6 X 10 (x4)

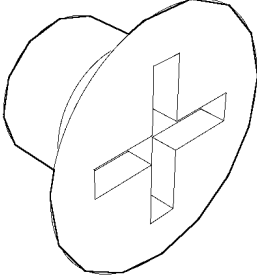

SCREW, M4 X 8 (x4)

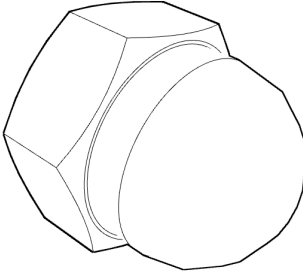

ACORN NUT, M6 (x4)

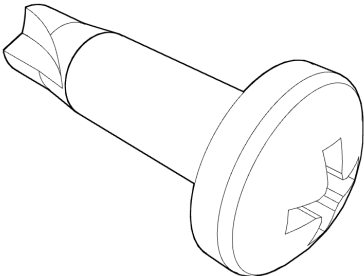

SELF-TAPPING SCREW (x4)

SHORT LINEAR SMARTWARES RAIL

SECTION 2 – INSTALLATION WITH TWO UNDERMOUNT BRACKETS

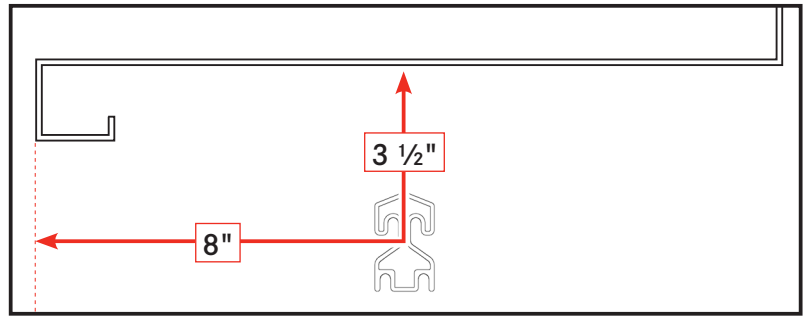

DETAIL G

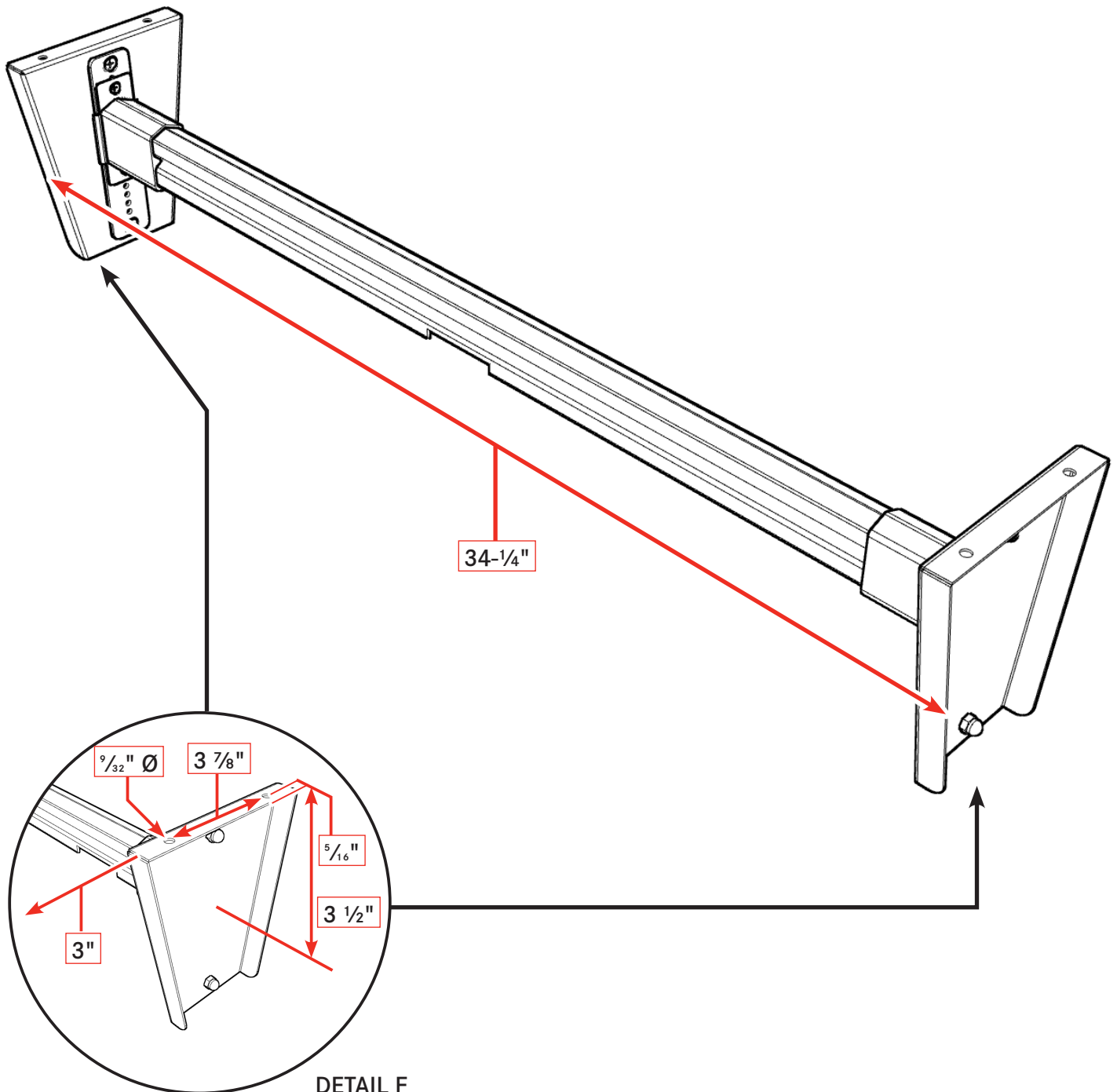

DETAIL F

SHORT DUAL SMARTWARES RAIL

SECTION 1 – KIT CONTENTS

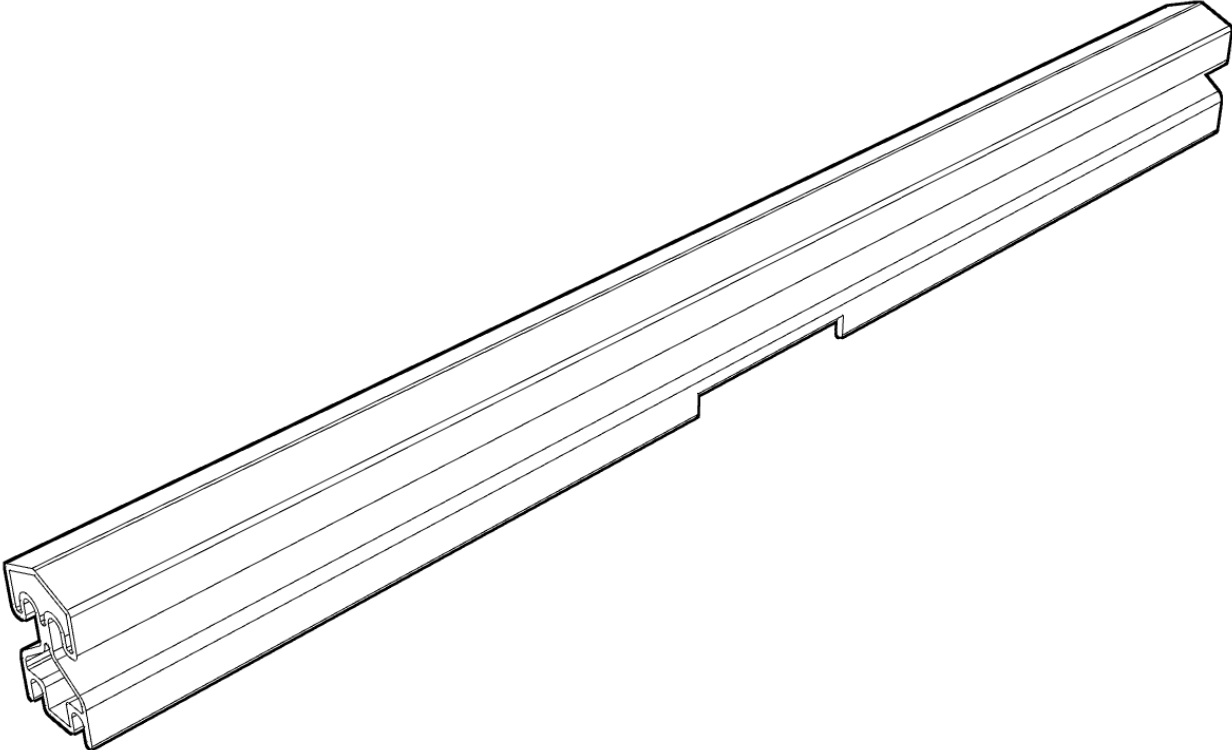

20-1/4" SMARTWARES RAIL

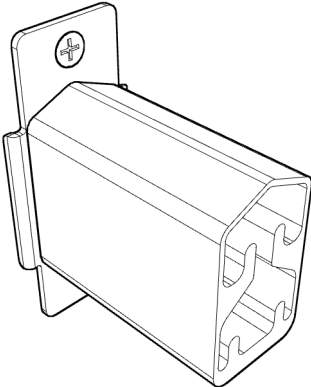

MOUNTING BRACKET (x2)

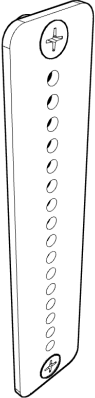

ADAPTER BRACKET (x2)

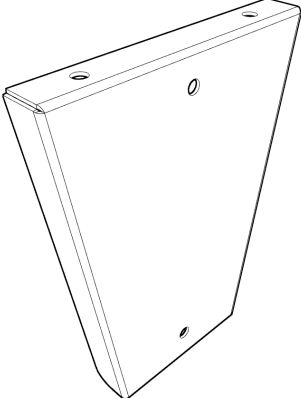

UNDERMOUNT BRACKET (x2)

HARDWARE KIT

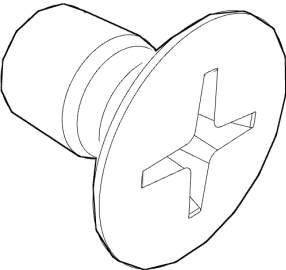

SCREW, M6 X 10 (x4)

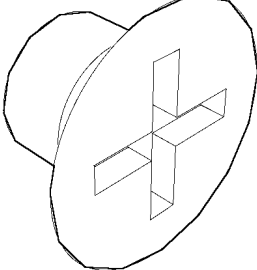

SCREW, M4 X 8 (x4)

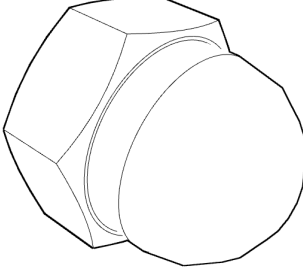

ACORN NUT, M6 (x4)

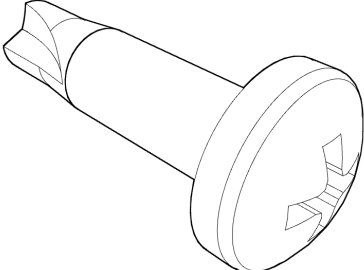

SELF-TAPPING SCREW (x4)

SHORT DUAL SMARTWARES RAIL

SECTION 2 – INSTALLATION WITH TWO UNDERMOUNT BRACKETS

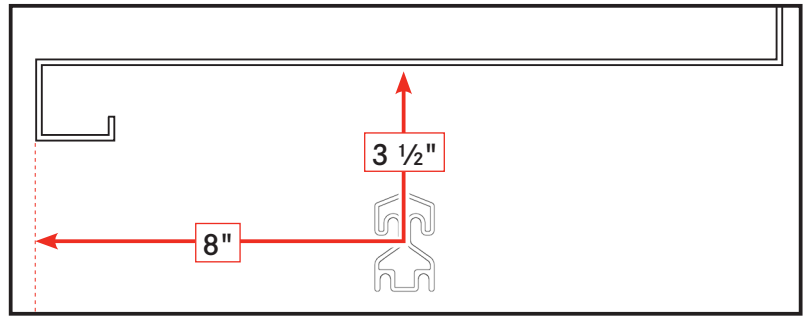

DETAIL G

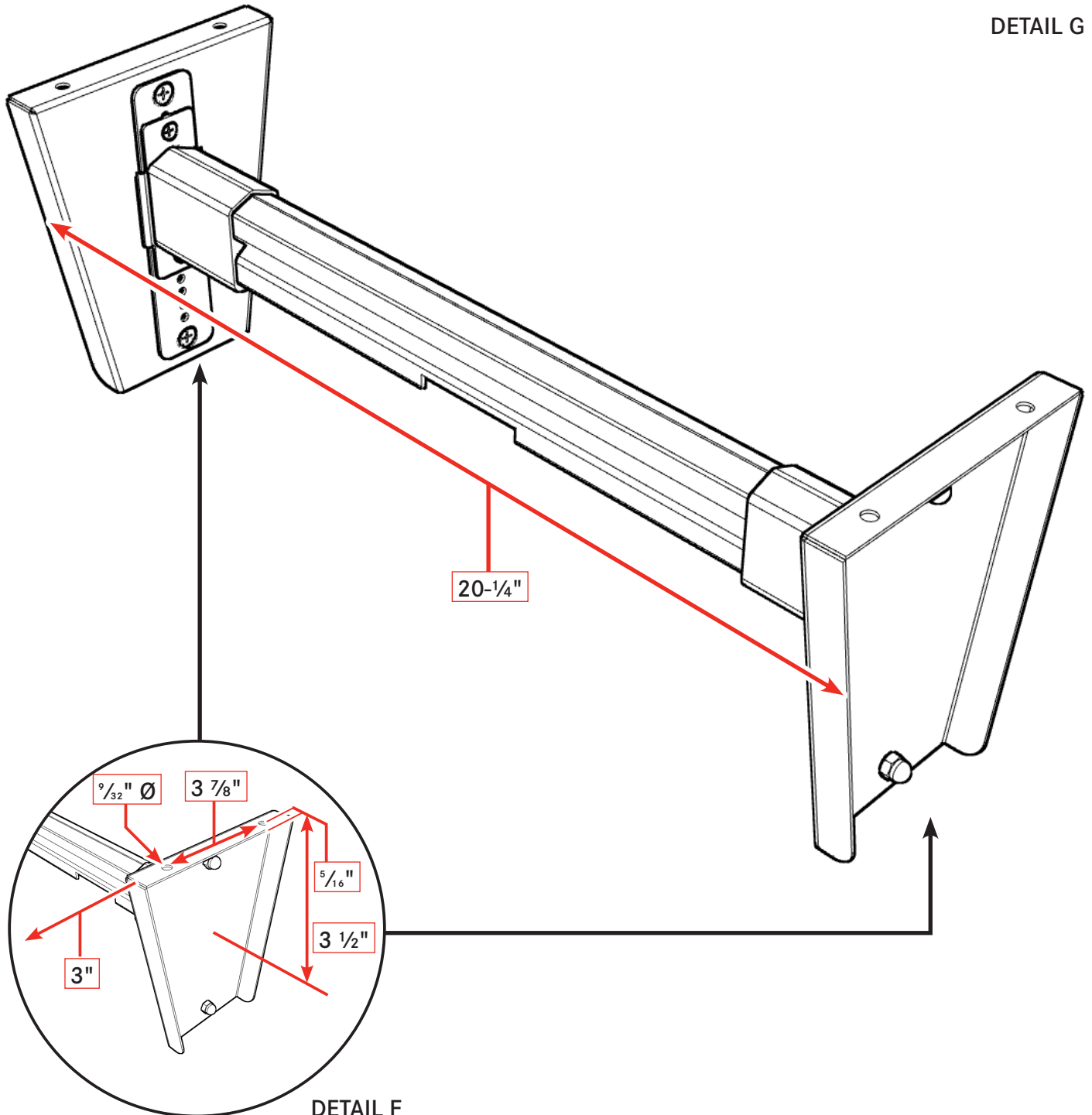

DETAIL F

LONG SMARTWARES RAIL

1

DETAIL H

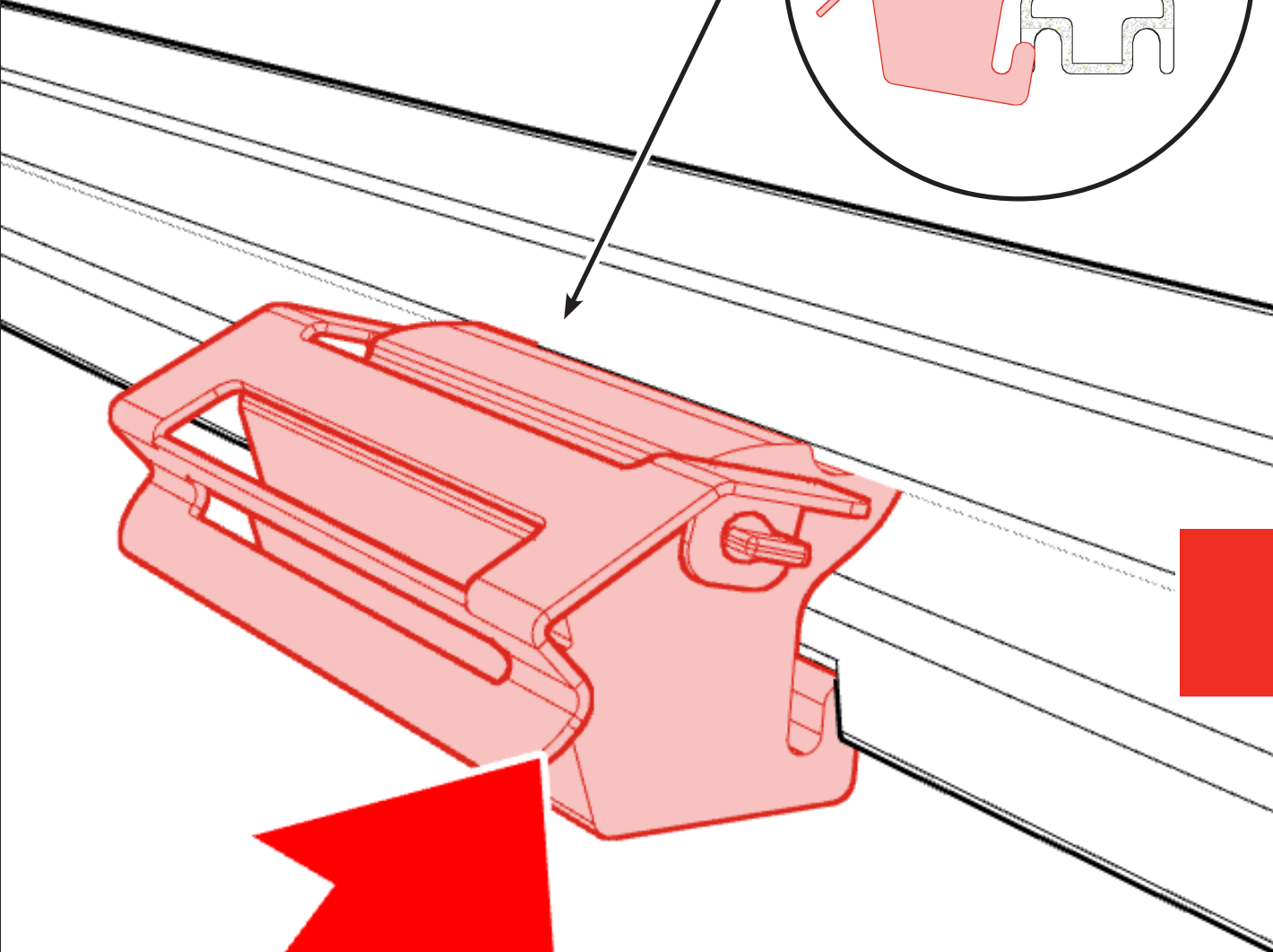
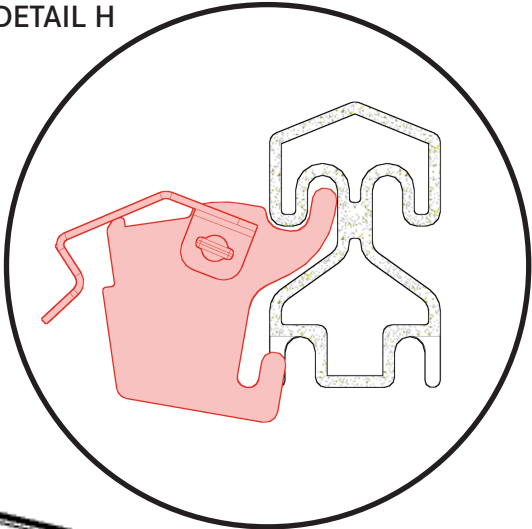

2

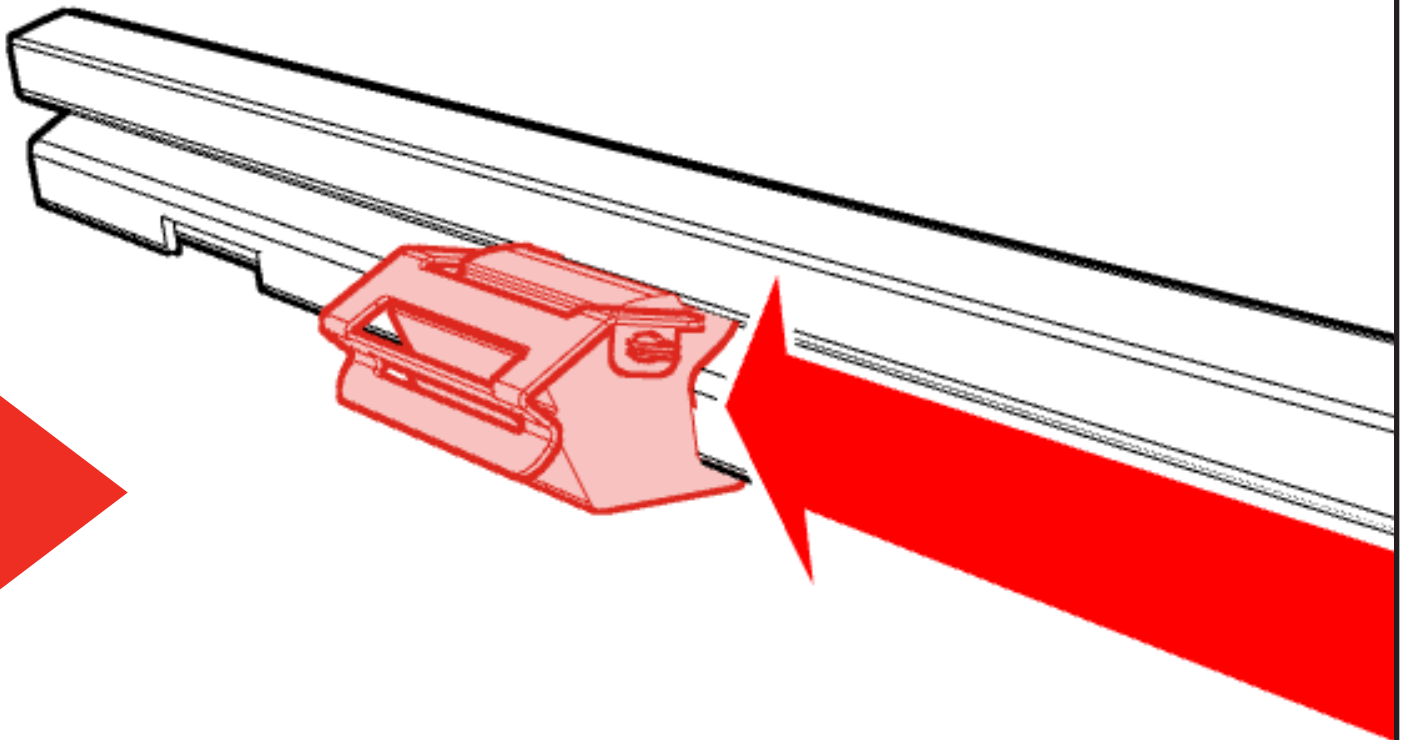

NOTICE

IMPORTANT INSTALLATION INFORMATION

Installation of Smartwares accessories varies per production line configuration. Consult provided Smartwares Placement Guide for detailed placement of Smartwares accessories.

NOTES

For Support, Please Call: 1.800.5.FRANKE, opt. 2 (1.800.537.2653, opt. 2)



**RECYCLE DOCUMENTS AND
EQUIPMENT RESPONSIBLY**

© 2019 Franke Foodservice Systems, Inc. This media is the confidential and proprietary property of Franke Foodservice Systems, Inc. and shall not be reproduced in any form of media without the express written permission of Franke. Trademarks used are the property of their respective owners. Due to continuous product development, Franke reserves the right to make changes in design and specifications without prior notice. Printed in the USA under license by Franke Technology and Trademark Ltd., Switzerland. Document Part # 19011996 REV B, 02-14-19