

Franke Sinfonia FSA

Technical Training Manual

Safety Information – Chapter 1

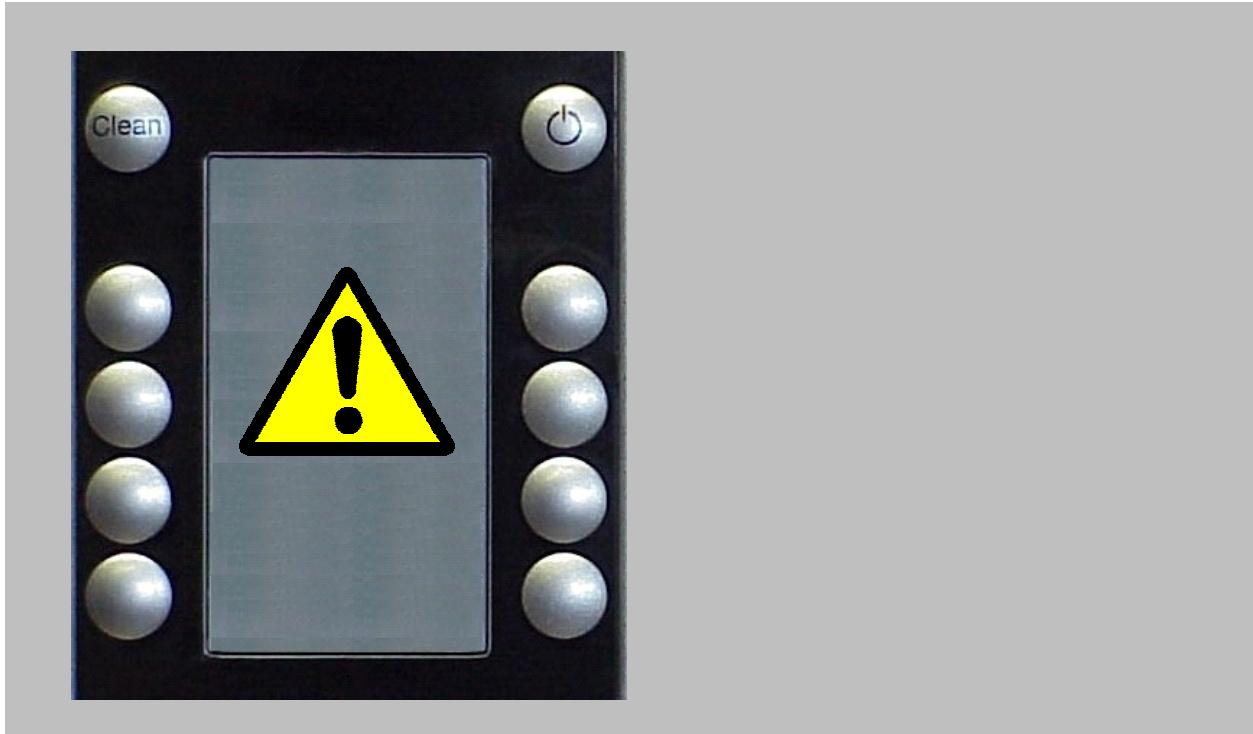

Franke Coffee Systems
800 Aviation Parkway
Smyrna, TN 37167
(615) 462-4000

Change log





Date	Changes	Author	Change No.	ID
2009-07-20	New Manual Concept	MPH		

Publisher:

Franke Kaffeemaschinen AG
 P.O. Box 235
 CH-4663 Aarburg
 Switzerland

www.franke-cs.com

Table of Contents

Change log	2
Table of Contents	3
Safety Notes	4
Safety	5
 DANGER	Electrical System..... 5
 DANGER	Steam System..... 5
 DANGER	Hydraulic System 5
 WARNING	Installation of machine..... 5
 CAUTION	For your health 6
NOTICE	Tools 6

Safety Notes

The installation, setting, repair and maintenance work described in these instructions must be performed only by service technicians trained by Franke Coffee Systems Americas Inc. and when using original Franke parts!

Observe the following dangers and warnings when servicing coffee machines with live voltage.



DANGER!
Indicates potentially life threatening Danger!
Electrocution caused by coming in contact with live voltage.
Safeguard parts with live voltage against contact.



WARNING!
Indicates risk of injury!
You may suffer injuries due to moving parts crushing fingers and hands.
Secure moving parts against unintentional movement.



CAUTION!
Indicates risk of minor injury!
Avoid burns caused by hot water, steam, hot milk, or milk foam



NOTE!
Indicates possibility of damage to the machine.

Safety



DANGER

Electrical System

Before performing maintenance on any electrical related component, ensure the following:

- Always disconnect from its power source before opening the machine.
- Ensure that the machine cannot be accidentally turned ON.
- Never operate a machine that has been damaged or has a damaged power supply cable. If the power supply cable to this machine is damaged, it must be replaced with an original power cord.
- Ensure that the machine and power cord are not near any hot surfaces such as gas or electric stoves or ovens.
- Ensure that the power cord is not pinched and does not rub against sharp edges. the machine contains electrically conductive parts. Opening the machine can pose risk of death.
- Do not make any modifications to the machine that are not described in the documentation from Franke.
- Repairs should only be made using original replacements and accessory parts.



DANGER

Steam System

Before performing maintenance on any steam related component, ensure the following:

- Disconnect the machine from the water supply.
- Always disconnect the machine from its power source.
- Empty the machine before performing any work on the boiler system.



DANGER

Hydraulic System

Before performing maintenance on any hydraulic related component, ensure the following:

- Disconnect the machine from the water supply.
- Always disconnect the machine from its power source.
- Empty the machine before performing any work on the boiler system.



WARNING

Installation of machine

Danger of injury and damage to the machine from improper installation

- Be clear on structural conditions before each installation.
- Evaluate the structural conditions in relation to the requirements.
- Observe local ordinances
- If the customer is unable to fulfill the conditions 100%
- Do not install or start-up the machine or accessories.
- Do not make the improvements at the customer site.
- The customer is responsible for making the needed improvements.
- Exercise care when making repairs or retrofits.
- Pay attention and work carefully.
- Keep hands away from the dispensers and nozzles during cleaning.



CAUTION

For your health

Danger of injury and damage to the machine from improper handling:

- Do not lift or move machine alone.
- Adhere strictly to the instructions in the manual.
- Do not touch the machine while it is operating.
- Only collect grounds in the container.

NOTICE

Tools

The following tools are recommended for servicing the Sinfonia

- Combination metric wrench set 7-19mm
- 7 and 8mm Metric Allen wrenches
- 3/16 x 4" Standard screwdriver
- 1/4 x 4" Standard screwdriver
- #1 Phillips screwdriver
- Mini screwdriver set
- Wire strippers/crimpers
- Diagonal pliers
- Slip-joint pliers
- Needle-nose pliers
- Teflon tape/paste
- Multi-meter with Amp Clamp
- Food grade lube - Part #296804
- Franke spindle lube - Part# 301340
- Franke grease - Part# 301313
- Bit driver with
 - #10 Torx bit
 - #15 Torx bit
 - #20 Torx bit
 - #25 Torx bit
- Franke Multi-tool

CAUTION

CAUTION!
Danger of injury!
Do not operate the coffee machine if either bean hopper is removed.
Serious injury could occur!

**WARNING**

WARNING!
Danger of burns!
Avoid burns caused by
hot water, steam, hot milk,
or milk foam

DANGER

DANGER!
Mortal Danger!
Electrocution caused by coming in contact with live voltage.
Safeguard parts with live voltage against contact.



Franke Sinfonia FSA

Technical Training Manual

Installation / Calibration – Chapter 2

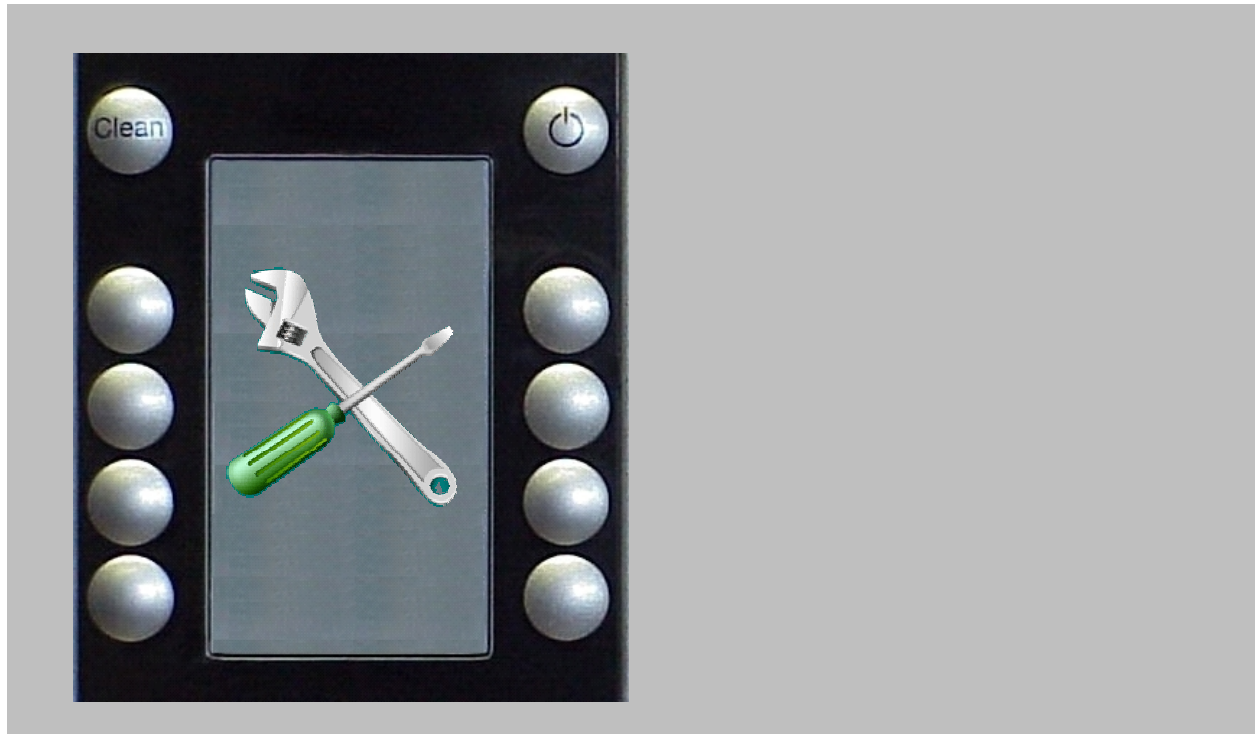

Franke Coffee Systems
800 Aviation Parkway
Smyrna, TN 37167
(615) 462-4000

Change log

Date	Changes	Author	Change No.	ID
2009-07-20	New Manual Concept	MPH		
2009-08-03	McD Start-Up Information	MPH		A
2009-11-23	Change software reference	MPH		B
2010-08-05	Changes to drink configuration file	MPH		C

Publisher:

Franke Kaffeemaschinen AG
 P.O. Box 235
 CH-4663 Aarburg
 Switzerland

www.franke-cs.com

Table of Contents

Change log	2
Table of Contents	3
Franke Sinfonia FSA.....	4
Installation.....	5
When unpacking the Sinfonia FSA, the following items should be included:.....	5
Water Requirements	5
Power Requirements.....	5
Drainage Requirements	5
Installation Guidelines.....	6
Sinfonia 1-Step McDonald's MUT	6
Turning the Sinfonia ON for the first time.....	8
Operating the Sinfonia	9
Preparing Coffee Products	9
Fresh ground coffee products.....	9
Dispensing hot water (available when the coffee machine has a hot water outlet).....	9
Preparing milk with the steam wand	9
Adjusting the Grind.....	10
Cleaning the Sinfonia FSA	11
Preliminary Procedure	12
Installation check.....	12
Calibration	13
Adjusting Product Fill Level and Temperature.....	14
McDonald's Fill Level and Temperature Guidelines	14
Product Cup Sizes	17
Making the Drinks	18
Fill Level and Temperature Adjustments Small / Medium / Large Products	21
Fill Level and Temperature Adjustments Small / Medium / Large Products	22
Fill Level and Temperature Adjustments Sample Products.....	23
Adjust Card Settings for FSA McDonald's.....	24

Franke Sinfonia FSA

Franke Sinfonia offers the most versatile array of performance and features for even the most demanding operations. Sinfonia's double boiler system delivers uncompromising power and consistency.

The Sinfonia FSA was designed to meet the McDonald specifications for superautomatic espresso machines used in McD family restaurants.

The Sinfonia FSA is equipped with a two boiler system. The steam boiler generates steam for preparing the milk based espresso beverages. The coffee boiler heats water to a specific, programmable temperature to precisely brew espresso at the proper temperature.

Standards

- Electronic control board with illuminated graphics display
- Chip-card programming
- High-performance piston coffee machine with pre-infusion
- Precision grinders (regular and decaf beans) with direct grinding
- Under counter milk pump solution for up to two different milk types
- Espresso based beverages with either hot or cold milk
- Easy operation panel with pre-selection buttons for four different drink sizes, second milk type, decaf beans and syrup option
- Integrated wash, rinse and sanitize cycle with user friendly menu guide
- Bean level monitoring in the brewing chamber
- Height-adjustable coffee and milk dispenser
- Dry coffee grounds container for up to 40 pucks
- Internal counter function for each product
- Stainless steel frame

Installation

When unpacking the Sinfonia FSA, the following items should be included:

- Drain Hose
- Hose Clamp (for securing the drain hose to the drip tray)
- Cleaning Tablets
- Cleaning Brush
- Water Supply Hose with gasket
- Milk Cleaning Solution and CF Brush set
- 3 Compartment Cleaning Container
- Equipment Manual
- Cleaning Instructions English and Spanish
- 1 Install Card, 1 Adjust Card
- 2 Mazzer bean hoppers
- 4 Leg Extensions
- 1 Leg Support (front left)



Water Requirements

Water hardness requirements for the Sinfonia FSA are between 3 to 5 grains per gallon (gpg) and 25 to 100 parts per million (ppm) of total dissolved solids (tds).

A dedicated water line with its own shut-off valve should be placed within four feet of the machine's installation location. The shut-off valve should be equipped with a male 3/8" compression fitting.

CAUTION! THE WATER INLET VALVE ON THE SINFONIA IS PLASTIC. USE CAUTION TO AVOID CROSS-THREADING THE FITTING WHEN RE-INSTALLING THE WATER LINE.

ENSURE ALL SOFTENING/FILTERING CARTRIDGES HAVE BEEN ADEQUATELY FLUSHED BEFORE RE-SUPPLYING WATER TO THE MACHINE.

Power Requirements

The Sinfonia FSA requires a 200-240V NEMA L6-30R power receptacle with a 30amp breaker.

Drainage Requirements

Ensure the drain hose provided with the machine runs downhill to an appropriate floor drain.

Installation Guidelines

Sinfonia 1-Step McDonald's MUT

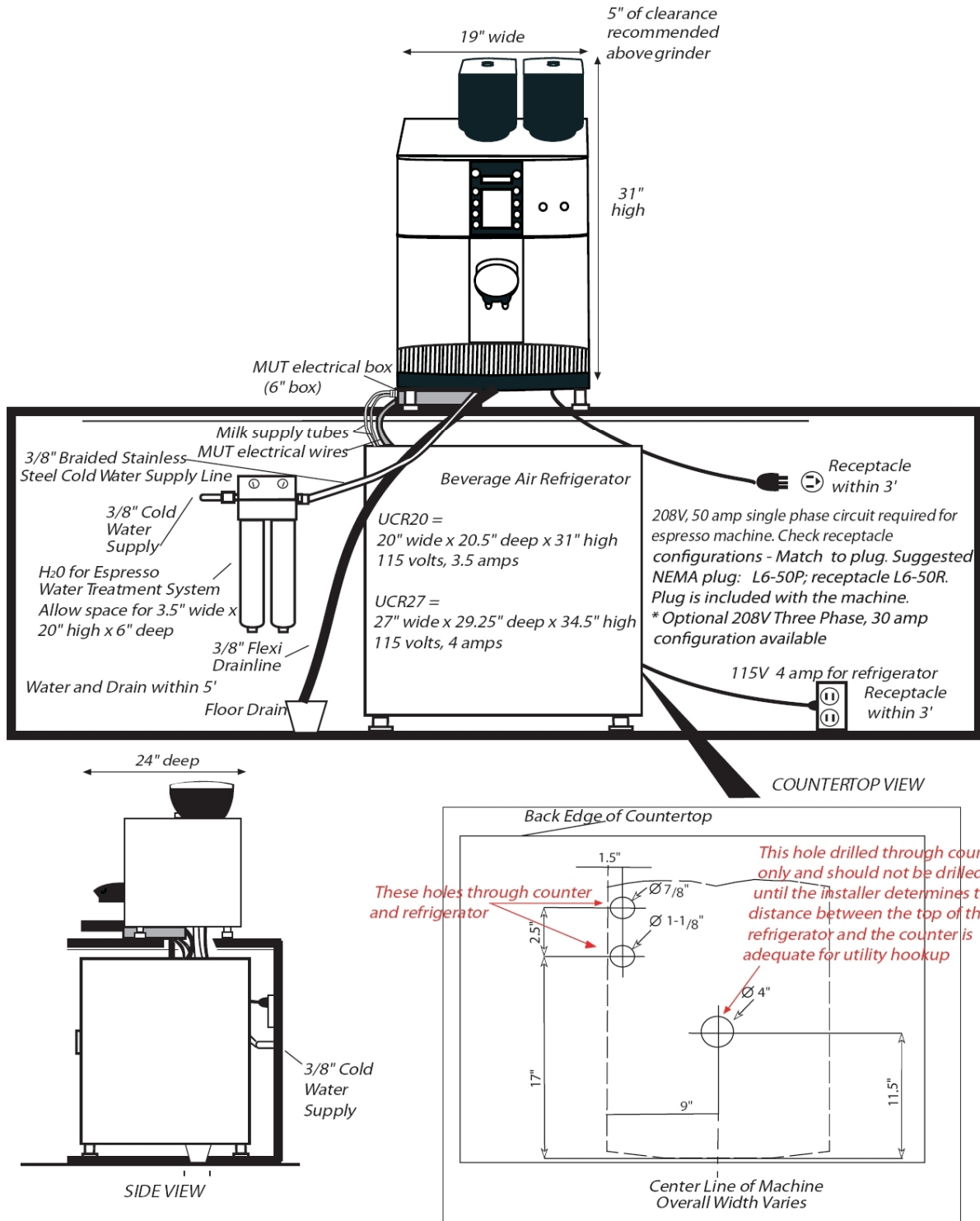

All Electrical and Plumbing Must meet Local Codes
Please Refer to Specification Sheets for Your Machine

Turning the Sinfonia ON for the first time

Once the machine has been properly installed:

1. Plug the machine into the wall outlet. While the machine is connected to the power supply but still turned off, the display will show the following message:

2. Turn on the main water supply.

3. Turn the machine on by pushing and releasing the ON/OFF button. The display will illuminate and display the self-test message; followed by two messages flashing in alternating sequence
 "Please wait" indicates that drink production is not yet possible. "Steam supply" indicates that the steam boiler is filling with water.

4. Once the boiler has filled to the proper level, the display will change to the following: "Please Wait" and "Heating". The heating elements are now activated, heating the water in both the boilers.

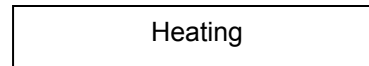
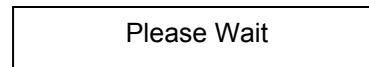
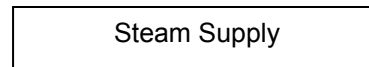
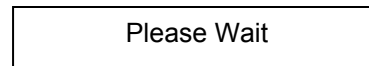
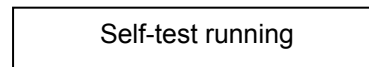
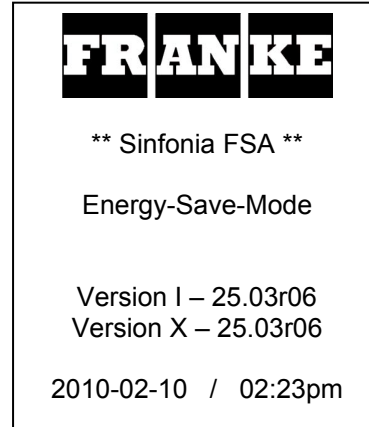

During the heating phase of the start-up cycle, the steam arm and hot water wand will open approximately every two minutes.

USE EXTREME CAUTION WHEN NEAR THE STEAM ARM AND HOT WATER WAND OUTLETS TO AVOID PERSONAL INJURY.

5. Once the proper steam pressure has been reached, the display will change to the following message. The machine is now ready for drink production

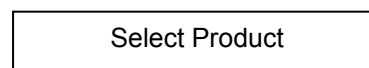

Operating the Sinfonia

Preparing Coffee Products

Fresh ground coffee products

1. Adjust the coffee outlet to the proper height.
2. Place the appropriate cup(s) under the coffee outlet.
3. Press the desired product button.
4. The display will show:

Dispensing hot water (available when the coffee machine has a hot water outlet)

1. Place a cup under the hot water nozzle.
2. Press the hot water button.

***If the hot water volume has not been programmed, simply push the hot water button again to stop the flow of water.**

Preparing milk with the steam wand

1. Place the steam wand tip into the pitcher of milk.
2. Press the steam button.
3. When the desired temperature or result is reached, press the steam button again to stop the flow of steam.

***If the machine is equipped with auto-steam, the steam will shut off at the pre-programmed temperature.**

Adjusting the Grind

The Sinfonia's grinders can be adjusted without removing the hoppers. To adjust the grind, perform the following:

1. Open the grounds container door.



2. Using the Franke multi-tool or a flat-tip screwdriver, unlatch the front display panel by turning the screw.

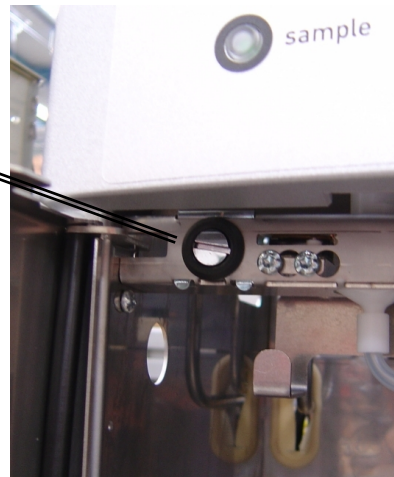

3. Locate the appropriate grind adjustment screw.
 - A. Adjusts the left grinder
 - B. Adjusts the right grinder

A

B

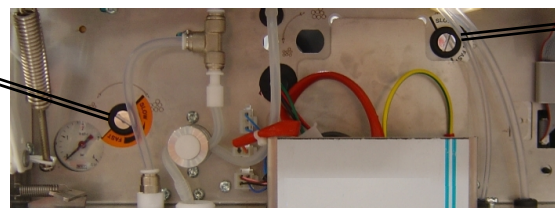

4. Rotate the screw in the appropriate direction to achieve the desired grind.

Rotate the screw clockwise to adjust the grind coarser for a faster extraction time.

Rotate the screw counter-clockwise to adjust the grind finer for a slower extraction time.

Generally, the grind is adjusted in full turn increments.

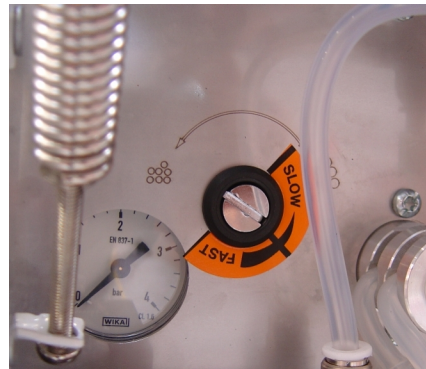

Cleaning the Sinfonia FSA

It is very important to clean the Sinfonia FSA coffee machine on a daily basis.

Please use the information given in the separately available cleaning instructions:

Manual Set Sinfonia FSA USA (English and Spanish) 1Y321069

Manual Set Sinfonia FSA Canada (English and French) 1Y321070

See Chapter 9 (Certificates and Check-Lists) for the actual Cleaning Instructions.

Preliminary Procedure

Installation check

Ensure that the machine is installed properly. Fill out the McDonald's Hook-Up check list completely.

- Proper power outlet – L6-30 and check voltage
- Check jumper position 200V (200-215) or 230V (216-240)
- Plug the machine in if not already and leave the machine in the OFF position (ESM)
- Test the water hardness. Should be between 3-5 grains per gallon (gpg) and 25-100 parts per million (ppm).
- Ensure the water line is connected and that the water is turned on
- Check for leaks
- Ensure the drain hose is routed properly to the drain receptacle
- Upload the newest Sinfonia FSA Software
- Ensure the MUT was installed and connected properly
- Place the appropriate containers of milk on the MUT and place the tubes in the milk

Turn coffee machine ON

- Ensure the machine fills with water (look for display message to read FILLING)
- Ensure the machine is heating
(look for display message to read "COFFEE HEATING" and then "STEAM/TEA HEATING")

Once the machine has reached temperature and pressure continue with the following procedure:

- Check the water pump pressure and adjust to 8 bar if found to be off

Install Menu > 4 Fluid System > 2 Pressure

The water pressure can be adjusted by rotating the adjustment screw clockwise to increase pressure and counterclockwise to decrease pressure. When done, set the adjustment screw by tightening the counter nut.

- Check the steam pressure, should be 1.8bar.
(TRAFAG pressure switch is non adjustable and must be replaced if offset more than 0.2bar)
- Using the Install card, delete the products from the machine.

Install Menu > 7 Data Back up > Clr Prods (Clear Products) > confirm with YES > SAVE

- Remove Install card
- Turn machine OFF (ESM)
- Upload Base configuration file with Service Tool FSA
- Turn machine ON
- Enter the milk correction menu

Calibration

The next step of the Start-Up procedure is Calibration. Before going on to this next step

IMPORTANT: Remove the cardboard inserts from the grinders.

If you have a new Sinfonia, turn the grinder adjustment screw 6 full turns coarser (FASTER)

Adjust the grinder so that a 10sec. Espresso shot is reached. Start counting when the water pump is turned on the first time and stop counting when the pump turns off at the end of the shot. (There is a 1second pre-infusion programmed on the Espresso shot.)

Under the Setup menu, go to Calibration

Install > 1 Setup > 15 Calibration

> MILL Calibration

- Double tap clean button to start Calibration
- Calibrate the Espresso puck for BOTH grinders.
- Take the average gram weight of 5 pucks for each grinder.
- Enter the gram weight for each grinder and SAVE

Calibrate coffee grinder right _____

Calibrate coffee grinder left (DECAF MILL) _____

Following Calibration recheck shot time, if grind adjustment is necessary repeat calibration procedure.

> MILK Calibration

- Prime milk pump 1 and milk pump 2
- Double tap clean button to start calibration
- Calibrate BOTH milk pumps
- Run the calibration process until you have two pours back to back within a couple of ml of each other.
- Enter the value for each pump and SAVE
- **Note: Once calibration has been completed never change this number unless replacing the pump.**

IMPORTANT

If the average calibration is below 100ml replace the pump.

Calibrate milk pump 1 (whole) _____

Calibrate milk pump 2 (non-fat) _____

Adjusting Product Fill Level and Temperature

Product Number Reference Guide

PRODUCT NAME	PRODUCT NUMBERS				
	SMALL	MEDIUM	LARGE	SAMPLE	ESPRESSO
CAPPUCCINO	01	05	09	13	
LATTE	02	06	10	14	
MOCHA	03	07	11	15	
ICED LATTE/MOCHA	04	08	12	16	
HOT CHOCOLATE	17	21	25		
ICED CHOCOLATE	18	22	26		
HOT SPECIAL	19	23	27		
ICED SPECIAL	20	24	28		
ADD MILK	31				
PRIME MILK	32				
ESPRESSO					33

McDonald's Fill Level and Temperature Guidelines

IMPORTANT

- **No changes to any of the drink recipes can be made.**
This includes, ground coffee gram weight and espresso fill level.
The only parameter adjustments to be made during drink calibration are those that affect milk fill levels and milk temperatures in order to achieve McD's specifications.
- **If anyone with the McD store staff or management has a complaint regarding any drink that is within the set specifications, please have them call their Deployment Manager!**
- **The default machine settings: coffee boiler temp, left & right grinder operation, etc. must remain as set by Franke Coffee Systems**
- **The target drink temperature for ALL hot drinks is 155°F – 170°F**
- **Cold drinks do not have a target drink temperature.**

IMPORTANT

When adjusting the Fill Level and Temperature on the NON FAT product item, you must enter the product definition menu for the corresponding drink and then select the NON FAT pre-select button before selecting FILL LEVEL or TEMPERATURE menu.

Install > Product definition > NON FAT button > 03 Fill level or 07 Temperature

Cappuccino

- The temperature settings for milk part 1 (steamed milk) on Cappuccinos are always 5 units higher than milk part 2 (frothed milk).
 - i.e. – Temperature milk part 1 = 72
 - Temperature milk part 2 = 67

(Select the NON FAT pre-select button to reach the NON FAT Fill Level and Temperature adjustment menu.)

Latte, Mocha, Hot Chocolate and Hot Special

- The temperature settings for milk part 1 (steamed milk) on Lattes, Mochas, and Hot Chocolates are always 10 units higher than milk part 2 (frothed milk).
 - i.e. – Temperature milk part 1 = 72
 - Temperature milk part 2 = 62

(Select the NON FAT pre-select button to reach the NON FAT Fill Level and Temperature adjustment menu.)

All Iced Drinks

- The temperature settings for milk part 1 (steamed milk) is defaulted to ZERO and milk part 2 (frothed milk) is 50 (minimum value)

Drink Menu	Drink Target Temps	Fill Levels	Notes
Cappuccino	167 F For non syrup drinks	1/8" Below rim of cup	1. When adjusting FILL LEVEL: If the drink is overfilled: - decrease mp1 (Steamed Milk) If the drink is short: - increase mp2 (Foamed Milk) 2. Milk reduction (flavor) setting must be adjusted for the Flavored Cappuccino products (see next page under Syrup)
Latte	162F For non syrup drinks	1/8" Below rim of cup	1. When adjusting FILL LEVEL: - ONLY adjust mp1 (steamed milk) 2. Milk reduction (flavor) setting must be adjusted for the Flavored Latte products (see next page under Syrup)
Mocha	160F	1/2" Below rim of cup	1. When adjusting FILL LEVEL: - ONLY adjust mp1 (steamed milk) 2. The TEMP setting for Mochas is generally 2 units higher than the Latte setting. 3. Milk reduction (flavor) setting for ALL Mochas drinks is 0ml (see next page under Syrup)
Iced Latte /Mocha	There is no target drink temp	1/8" Below rim of cup	1. When adjusting FILL LEVEL: - ONLY adjust mp1 (steamed milk) 2. Milk reduction (flavor) setting must be adjusted for the Iced Latte/Mocha products (see next page under Syrup)



Drink Menu	Drink Target Temps	Fill Levels	Notes
Hot Chocolate	157F	1/2" Below rim of cup	<ol style="list-style-type: none"> When adjusting FILL LEVEL: - ONLY adjust mp1 (steamed milk) The TEMP setting for Hot Chocolate is generally the same as the Cappuccino and Latte setting.
Iced Chocolate	There is no target drink temp	1/8" Below rim of cup	<ol style="list-style-type: none"> When adjusting FILL LEVEL: - ONLY adjust mp1 (steamed milk) Milk reduction (flavor) setting for ALL Iced Special drinks is 0ml (see next page under Syrup)
Hot Special	160F	1/2" Below rim of cup	<ol style="list-style-type: none"> When adjusting FILL LEVEL: - ONLY adjust mp1 (steamed milk) Milk reduction (flavor) setting for ALL Hot Special drinks is 0ml (see next page under Syrup)
Iced Special	There is no target drink temp	1/8" Below rim of cup	<ol style="list-style-type: none"> When adjusting FILL LEVEL: - ONLY adjust mp1 (steamed milk) Milk reduction (flavor) setting for ALL Iced Special drinks is 0ml (see next page under Syrup)

Sample Sizes (Select the NON FAT pre-select button to reach the NON FAT Fill Level and Temperature adjustment menu.)

- The cup size for the sample size for **Hot** drinks is 8oz.
- The cup size sample size for **Cold** drinks is 7oz.
- Fill the cup with 2.5oz of ice.

Syrup (Milk Reduction – Flavor) (Select the NON FAT pre-select button to reach the NON FAT Fill Level and Temperature adjustment menu.)

- The syrup button FILL LEVEL setting is accessed via the “Output Variation” screen.
- Enter the value that you need to reduce the mp1 to make room for the syrup
- Milk reduction (flavor) settings for the Cappuccino, Latte and Iced Latte/Mocha drinks may vary
- Milk reduction (flavor) setting for ALL **Hot Mocha** drinks is **0ml**
- Milk reduction (flavor) setting for ALL **Hot Chocolate** drinks is **0ml**

Install > Product definition > 04 Outlet variation > syrup

Syrup amounts in the drinks are:

Hot Cappuccino with Flavor

- Small = 4 pumps
- Medium = 5 pumps
- Large = 6 pumps
- Sample = 2 pumps

Iced Latte/Mocha with Flavor

- Small = 3 pumps
- Medium = 4 pumps
- Large = 6 pumps
- Sample = 2 pumps

Hot Latte with Flavor

- Small = 4 pumps
- Medium = 5 pumps
- Large = 6 pumps
- Sample = 2 pumps

Hot Chocolate / Iced Chocolate

- Small = 4 pumps
- Medium = 5 pumps
- Large = 6 pumps

Hot Mocha with Flavor

- Small = 4 pumps
- Medium = 5 pumps
- Large = 6 pumps
- Sample = 2 pumps

Hot Special

- Small = 4 pumps
- Medium = 5 pumps
- Large = 6 pumps

Iced Special

- Small = 3 pumps
- Medium = 4 pumps
- Large = 6 pumps

Add Milk (Select the NON FAT pre-select button to reach the NON FAT Fill Level and Temperature adjustment menu.)

- The Add Milk button is found on the Special Products preselect menu.
- The button is programmed to permanent. The milk will dispense as long as the button is pressed.
- Set the temperature to 160°-165°F.

Product Cup Sizes

	CUP SIZES			
PRODUCT DRINKS	SMALL	MEDIUM	LARGE	SAMPLE
HOT DRINKS	12oz.	16oz.	20oz.	8oz.
COLD DRINKS	12oz.	16oz.	22oz.	7oz.

Making the Drinks

Cappuccino



Nonfat button (if ordered)



Syrup button (if flavored cappuccino is ordered)



Size button (Small, Medium, Large, Sample)



Cappuccino drink button

Latte



Nonfat button (if ordered)



Syrup button (if flavored latte is ordered)



Size button (Small, Medium, Large, Sample)



Latte drink button

Mocha



Nonfat button (if ordered)



Syrup button – ALWAYS SELECT THE SYRUP BUTTON ON THE MOCHA DRINK



Size button (Small, Medium, Large, Sample)



Mocha drink button

Iced Latte/Mocha

Nonfat button (if ordered)



Syrup button – (if flavored iced latte/mocha is ordered)



Size button (Small, Medium, Large, Sample)



Iced Latte/Mocha drink button

Hot Chocolate

Nonfat button (if ordered)



Syrup button– ALWAYS SELECT THE SYRUP BUTTON ON THE HOT CHOCOLATE DRINK



Special products button



Size button (Small, Medium, Large)



Hot Chocolate drink button

Iced Chocolate

Nonfat button (if ordered)



Syrup button– ALWAYS SELECT THE SYRUP BUTTON ON THE ICED CHOCOLATE DRINK



Special products button



Size button (Small, Medium, Large)



Iced Chocolate drink button

Hot Special



Nonfat button (if ordered)



Syrup button– ALWAYS SELECT THE SYRUP BUTTON ON THE HOT SPECIAL DRINK



Special products button



Size button (Small, Medium, Large)



Hot Special drink button

Cold Special



Nonfat button (if ordered)



Syrup button– ALWAYS SELECT THE SYRUP BUTTON ON THE COLD SPECIAL DRINK



Special products button



Size button (Small, Medium, Large)



Cold Special drink button

Add Milk



Nonfat button (if ordered)



Special products button



Sample Size button



Add Milk button – Keep pressing the button until the desired drink level is reached.
Release the button to stop milk flow.

Fill Level and Temperature Adjustments Small / Medium / Large Products

PRODUCT NAME	SMALL				MEDIUM				LARGE			
	FILL LEVEL		TEMP		FILL LEVEL		TEMP		FILL LEVEL		TEMP	
	MP1	MP2	MP1	MP2	MP1	MP2	MP1	MP2	MP1	MP2	MP1	MP2
CAPPUCCINO												
NON FAT CAPPUCCINO												
CAPPUCCINO with FLAVOR	Outlet Variation Syrup in ml				Outlet Variation Syrup in ml				Outlet Variation Syrup in ml			
LATTE												
NON FAT LATTE												
LATTE with FLAVOR *	Outlet Variation Syrup in ml				Outlet Variation Syrup in ml				Outlet Variation Syrup in ml			
MOCHA												
NON FAT MOCHA												
ICED LATTE/MOCHA												
NON FAT ICED LATTE/MOCHA												
ICED LATTE/MOCHA WITH FLAVOR *	Outlet Variation Syrup in ml				Outlet Variation Syrup in ml				Outlet Variation Syrup in ml			
HOT CHOCOLATE												
NON FAT HOT CHOCOLATE												



Fill Level and Temperature Adjustments Small / Medium / Large Products

continued	SMALL				MEDIUM				LARGE			
PRODUCT NAME	FILL LEVEL		TEMP		FILL LEVEL		TEMP		FILL LEVEL		TEMP	
	MP1	MP2	MP1	MP2	MP1	MP2	MP1	MP2	MP1	MP2	MP1	MP2
ICED CHOCOLATE												
NON FAT ICED CHOCOLATE												
HOT SPECIAL												
NON FAT HOT SPECIAL												
ICED SPECIAL												
NON FAT ICED SPECIAL												
ADD MILK												
ADD MILK NON FAT												

Fill Level and Temperature Adjustments Sample Products

PRODUCT NAME	SAMPLE			
	FILL LEVEL		TEMP	
	MP1	MP2	MP1	MP2
CAPPUCCINO				
NON FAT CAPPUCCINO				
CAPPUCCINO with FLAVOR	Outlet Variation Syrup in ml			
LATTE				
NON FAT LATTE				
LATTE with FLAVOR *	Outlet Variation Syrup in ml			
MOCHA				
NON FAT MOCHA				
ICED LATTE/MOCHA				
NON FAT ICED LATTE/MOCHA				
ICED LATTE/MOCHA WITH FLAVOR *	Outlet Variation Syrup in ml			

There are NO SAMPLE HOT CHOCOLATE drinks!

Adjust Card Settings for FSA McDonald's

Use the Install card to set the cleaning prompt and the cleaning lockout time based on the managers recommendation

Install > Setup > 08 Cleaning 1> Request

Install > Setup > 08 Cleaning 1> Force

Install > Setup > 09 Cleaning 2> Request

Install > Setup > 09 Cleaning 2> Force

Use the Adjust card to change the Date and Time.

Double check that ONLY the Menu Date and Time is visible in the Customer Adjust Menu.

Customer Menu > 02 Clock > Date / Time

If other Menus are visible in the Customer Menu selection, check the Adjust settings in the Service Tool FSA Configuration File.

All Adjust A parameters should be disabled with a check mark except for:

- 2 Clock – Date / Time.
- 7 Show counters

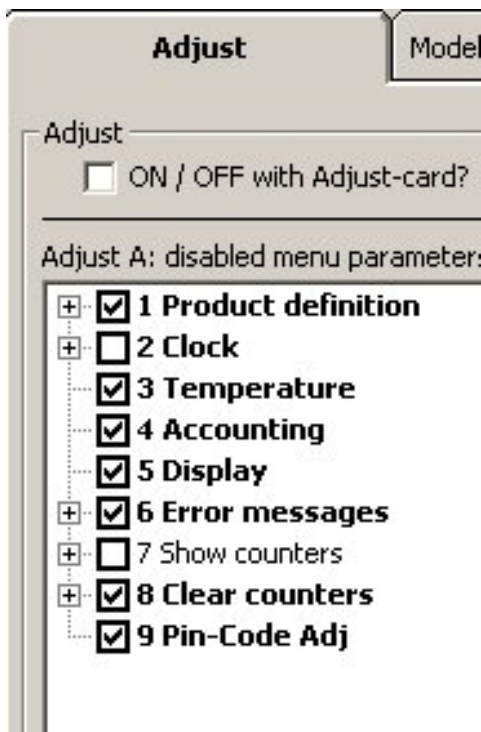

Turn off the machine

Save the product configuration file to your computer using the Service Tool FSA.

Double check the values for each drink and make corrections if needed. Upload the configuration file to Sinfonia if you made any changes to the file.

Franke Sinfonia FSA

Technical Training Manual

Repairs / Planned Maintenance – Chapter 3



Franke Coffee Systems
800 Aviation Parkway
Smyrna, TN 37167
(615) 462-4000

Change log

Date	Changes	Author	Change No.	ID
2009-07-20	New Manual Concept	MPH		
2009-11-23	Grinders, Table of contents PM-instructions	MPH		A

Publisher:

Franke Kaffeemaschinen AG
 P.O. Box 235
 CH-4663 Aarburg
 Switzerland

www.franke-cs.com

Table of Contents

Change log	2
Table of Contents	3
Safety Notes	4
Preventive Maintenance	5
Grinders	7

Safety Notes

The installation, setting, repair and maintenance work described in these instructions must be performed only by service technicians trained by Franke Coffee Systems Americas Inc. and when using original Franke parts!

Observe the following dangers and warnings when servicing coffee machines with live voltage.



DANGER!
Indicates potentially life threatening Danger!
Electrocution caused by coming in contact with live voltage.
Safeguard parts with live voltage against contact.



WARNING!
Indicates risk of injury!
You may suffer injuries due to moving parts crushing fingers and hands.
Secure moving parts against unintentional movement.



CAUTION!
Indicates risk of minor injury!
Avoid burns caused by hot water, steam, hot milk, or milk foam



NOTE!
Indicates possibility of damage to the machine.

Planned Maintenance

Planned Maintenance Schedules / Checklist

Insert the following documents here:

- PM1 Checklist
- PM1 Work Instructions

- PM1-B Checklist
- PM1-B Work Instructions

- PM1-H Checklist
- PM1-H Work Instructions

- PM2 Checklist
- PM2 Work Instructions

- PM2-B Checklist
- PM2-B Work Instructions

- PM2-H Checklist
- PM2-H Work Instructions



Grinders

Replacement of grinding discs

1. Disconnect power supply from the coffee machine. Remove the bean hopper and upper panel.
2. Release clamp [1] and remove it.
3. Place a mark on the grinder at the front end of the adjustment mechanism before removing it. (see drawing point A)
4. Place the adjustment mechanism off to the side. Remove the stopper ring (not shown).
5. Turn the stationary discs flange [3] counter-clockwise and remove it.
6. Unscrew the grinding discs [4] (3 screws) from the stationary- and rotary disc flanges. To block the rotary disc flange [6], use a 12mm wrench to hold the finger guard.
7. Use a brush or cloth to clean the surfaces of the flanges.
8. Assemble the new grinding disc on the cleaned rotary- and stationary disc flanges and tighten screws carefully.
9. Remove all coffee particles or dust from the threads on the stationary disc flange and lubricate lightly using food grade grease.
10. Re-install the stationary disc flange by turning clockwise slowly until the slight noise of touching grinding discs appears.
11. Install the clamp [1] and the grind adjustment mechanism [2].
12. Increase the grinding disc clearance by turning the adjustment screw clockwise 8 complete turns.
13. Install the stopper ring, placing the stopper nose directly at the marking made at the front end of the adjustment mechanism (see step 3). (The stopper should now prevent the decrease of the grind clearance when turning the adjustment screw counter-clockwise).
14. Increase the grinding disc clearance by turning the adjustment screw clockwise another 6 complete turns.
15. Install upper panel and bean hopper. Reconnect power supply to the coffee machine.
16. Complete grinder adjustment according to start-up guide/customer specifications.

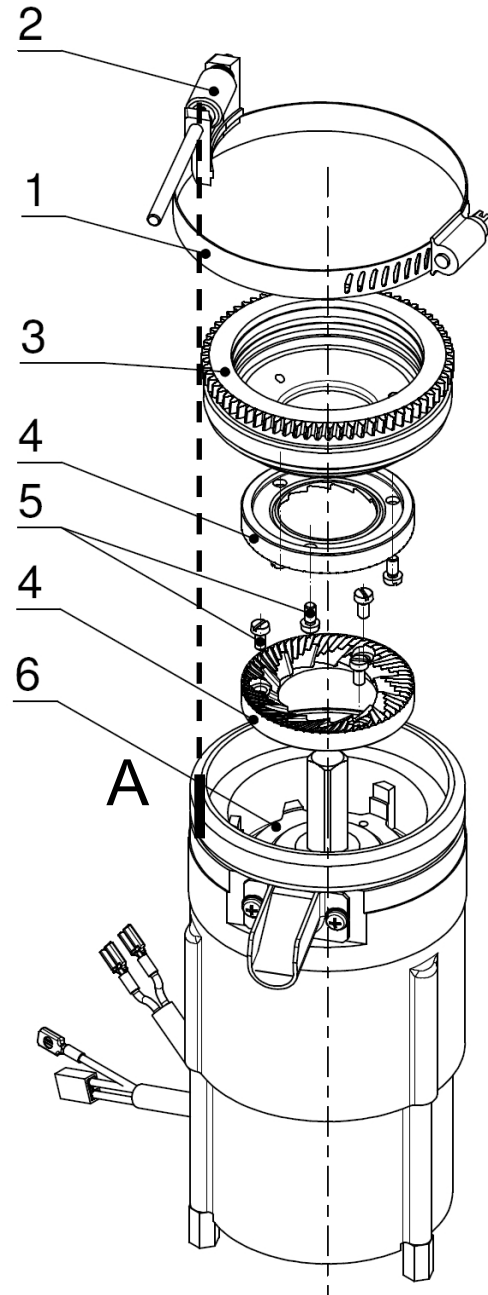



McDonalds Sinfonia FSA USA and Canada PM2 Check List
PLEASE MAIL COMPLETED CHECKLIST WITH INVOICE to Ensure Payment

Service Provider Name		Work Order #	
Date of Service		Technician Name and #	
Time In		National Store #	
Time Out		Address Line 1	
Machine Count		Address Line 2	
Cycle Count		Phone #	
Clean Count		Wall Voltage	
Outlet Water Hardness (GPG)		Outlet Water Hardness (TDS)	
RO Water Hardness (GPG) – if necessary		RO Water Hardness (TDS) – if necessary	
Sink Water Hardness (GPG) – if necessary		Sink Water Hardness (TDS) – if necessary	
Serial Number		Product Count	
Cleanings Per Day (Please Circle)	1 or 2	Cleaning Supplies Available (Please Circle)	YES or NO
Coffee Responsible Available? (Please Circle)	YES or NO		

Ref. #	Instruction to Complete	Check When Complete
1	Check for any special instructions (i.e. – Service Information Memos, Software Revisions, Extra Repairs) prior to performing PM	
2	Measure the Water Hardness of the store in Grains Per Gallon (GPG) and Total Dissolved Solids (TDS) and record in the spaces provided at the top of the Check List	
3	Begin a cleaning cycle	
4	Inspect the Hot Water Valve Block for leaks	
5	Replace the Heater Relays	
6	Download Configuration File from machine (Record Date, City, Store # and PM Designation #) and ensure that the Firmware is version 25.03r37 or above	
7	Remove and clean the Upper Piston	
8	Replace all Silicon Tubing inside Sinfonia FSA	
9	Clean the Check Valves on both Milk Pumps (replace Seal Cones and Spring to Milk System)	
10	Replace the Milk Pickup Silicone Tubing	
11	Perform calibration procedure for both Grinders and Milk Pumps	
12	Ensure that the Espresso Shot meets the McDonalds Standard	
13	Ensure that Sanitize Cycle Time is set to 100 s (50 s per Milk Pump)	
14	Ensure all drink fill levels and temperatures are accurate (See Drink Configuration Menu on Work Instruction)	
15	Update PM Log Sticker on inside of Grounds Container Door as well	
16	Review the Hot Water Sanitize McDonalds cleaning procedure with the (US) Coffee Responsible/ (CAN) McCafé Coordinator and ensure that they are following all the steps properly	

Extra Information: _____

Abnormal Machine Conditions: _____

No additional repairs are authorized. Please call Technical Support for authorization

Store Manager's Signature: _____ *Technician's Signature: _____

Store Manager Printed Name: _____ Technician's Printed Name: _____

*By signing this document, I certify that I have completed all tasks listed in the Franke Sinfonia FSA PM2 Work Instruction



MCDONALDS SINFONIA FSA

PM 2

6/8/2011



COFFEE
SYSTEMS

FRANKE

WELCOME TO THE SINFONIA FSA PERIODIC MAINTENANCE PROGRAM

Contents

Purpose of PM & Scope	3
Supplies Needed	5
First Steps	6
Tasks While Cleaning Cycle is Running	9
Brew Area Maintenance	10
Replace Tubing	11
Replace Hot Water Valve Block	12
Machine Lubrication	13
Milk System Maintenance	14
Electrical Confirmation	16
Operational Checks and Final Customer Services	17

Total Time: 1 Hour 55 Min

KEY LABELS

Blue text in a blue box:
Tools needed for this task

Red text in a red box:
Parts Replaced for this Task

Black Bold Text:
Key terms throughout the
instruction

Green Bold Text:
See photo reference for
instruction

**PURPLE ALL CAPS BOLD
TEXT:
ADDITIONAL NOTE FOR THE
INSTRUCTION**

Purpose of the Periodic Maintenance Program

The Periodic Maintenance Program can be defined as a set of proactive checks, adjustments and repairs done in regular intervals by a trained technician to provide our customers with a reliably excellent product. In this last revision of the PM Program you will find many minor tweaks, as well as some major alterations, that take better aim at this definition. The goal of this document is first and foremost directed at offering our customers the best possible product on all levels.

Scope of this Document

There are two factors that define the scope of this document. The first factor is seen in the increased detail of the PM Work Instruction. The PM Work Instruction is set in place with the goal of providing excellent service and operation standards for all of our customers. Considering this fact, the PM Work Instruction can be considered fairly restrictive. The second factor addresses the responsibilities of the Service Provider and our attempt to make them easier to define. In the process of heavily defining every detail of this program, we hope to minimize factors such as preparation time and individual task time while streamlining the work flow. This, in essence, gives the Service Provider a greater opportunity to view the overall condition of the coffee machine. It should be noted that no matter how detailed the program or document becomes, it cannot replace the awareness of a trained technician as they interact with the machine during maintenance. Considering this fact, the PM Work Instruction is considered measurably more liberating than its predecessor. It is hoped that as a Service Provider using this document, you would take both factors into consideration and use this tool to its fullest potential to become a valuable extension of expertise and service to our valued customers.

Supplies Needed

- Pen
- Install Card (300931)
- Franke Milk Cleaner (301732)
- Franke Coffee Cleaner Tablets (300935)
- Franke 3 Compartment Container (320683)
- Franke Cleaning Brush Set (301376)
- 2 x Franke Multitool (310252)
- Mavea Titration Kit (301795)
- HM Digital TDS-3 Meter (141786)
- Torx T20 Driver
- Side Cutters
- Laptop with Windows XP SP2 or SP3
- Service Tool FSA software
- USB Cable with Franke USB-to-Serial Converter (320713)
- Sanitized Towels
- Sharpie Pen
- Pick
- 13 mm Combination Wrench
- Medium Flat Head Driver
- Small Phillips Head Driver
- Pliers
- Sanitized Towels
- Multimeter
- Scratch Pad
- Gram Scale
- Coffee Beans
- 200 ml Graduated Cylinder
- McDonalds Drink Cups in all supplied Sizes
- Franke Milk Cleaner (301732)
- Franke Coffee Cleaner Tablets (300935)
- Thermometer
- Sink
- (US) Whole and Nonfat / (CAN) 2% and Skim Milk

- Foamer Steam Coupler Inner Check Valve (326168)
- Foamer Splitter O-Ring (310646)
- Foamer Check Valve O-Rings (310192 and 301007)
- Foamer Milk and Air-Steam Coupler O-Ring (301007)
- Foamer Steam Coupler O-Ring (301192)
- Silicone Tubing (296485)
- Milk Pickup Silicone Tubing (320753)
- 4 x Seal Cones (310622)
- 2 x Spring to Milk System (310644)
- Check Valve Silicone Tubing (296485)
- 2 x Heater Relay (296926)

First Steps (14 min)

- Install Card
- Mavea Titration Kit
- HM Digital TDS-3 Meter
- Small Paper Cup

- Foamer Steam Coupler Inner Check Valve
- Foamer Splitter O-Ring
- Foamer Air Check Valve O-Rings
- Foamer Milk and Air-Steam Coupler O-Ring
- Foamer Steam Coupler O-Ring

1. Check for special instructions that may have been added onto this maintenance request (i.e. - Service Information Memos, Extra Repairs, etc.).
2. Record the Machine Counters

- a. Insert **Install Card** into machine at left lower hand side of **Display Front Panel** with chip card facing upward and toward the machine <Figure 1>.



Fig. 1

- i. The “Clean” Button is used to select items or enter menu levels <Figure 2>.
- ii. The “Up/Down” arrow set is used to navigate through the menu.
- iii. The “+/-” button set are used to adjust values inside the menu.
- iv. The “Back” button is used to return to the previous menu level.



Fig. 2

- b. Type the password (0001) to enter the **Install Menu** and gather information for the Check List. Use space provided at top of **PM Check List** to record the **Machine Total**, **Cycle Count** and **Cleaning Cycles**, **Product Totals** and the **Autofill Probe Variable**.



Fig. 3



Fig. 4

- c. The following menu paths can be used to find the counters.

- i. **Machine Count:** 5 View Counters - 1 Machine - Machine Total
- ii. **Cycle Count:** 5 View Counters - 1 Machine - Cycles Total
- iii. **Cleaning Cycles:** 5 View Counters - 1 Machine - Total Cleanings
- iv. **Product Totals:** 5 View Counters - 2 Prod. Total - Coffeeprod. Total
- v. **Cleanings Per Day:** 1 Set-up - 9 Cleaning 2
- vi. **Autofill Probe Variable:** 4 Fluid System - Niv Boil (4 digit value)

NOTE - IF THE VALUE IS BETWEEN 0400-0500 WHEN THE BOILER IS FULL, THEN THE AUTO-FILL PROBE IS FUNCTIONING WITHIN NOMINAL CONDITIONS. BUT IF THE VALUE IS 0600 OR MORE WHEN THE BOILER IS FULL, THEN THE AUTO-FILL PROBE WILL NEED TO BE CLEANED. PLEASE CONSULT FRANKE TECH SUPPORT IF THIS ACTION IS NECESSARY. THE BEST TIME TO COMPLETE THIS MAINTENANCE IS DURING THE “ELECTRICAL CONFIRMATION” SECTION.

3. Measure the **Water Hardness** of the store in **Grains Per Gallon (GPG)** and **Total Dissolved Solids (TDS)** and record in the spaces provided at the top of the Check List

NOTE - IN ORDER FOR THE WORK ORDER TO BE PROCESSED, THE WATER SAMPLE DATA MUST BE RECORDED AT THE TOP OF THE PM CHECK LIST.

- a. To test the store’s **Water Hardness** using **Grains Per Gallon**, use the following steps:
 - i. Run a rinse cycle by double tapping the **Clean Button** <Figure 3>.
 - ii. Using a **Small McDonalds Paper Cup**, collect the rinse water from the **Foamer Outlet** while running a second rinse cycle <Figure 4>.

First Steps Continued

NOTE: THE TEST WATER MUST BE COLD, SO ONLY COLLECT THE COLD RINSE WATER FROM THE FIRST PART OF THE RINSE CYCLE. IT IS BEST TO REMOVE THE CUP AFTER THE ESPRESSO HAS FINISHED RINSING TO AVOID COLLECTING ANY STEAM FROM THE FOAMER OUTLET.

- iii. Follow the instructions included in the **Mavea Titration Kit <Figure 5>** to measure temporary hardness in **GPG** and record the result in the space provided at the top of the **PM Check List**.

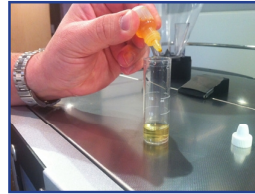

Fig. 5



Fig. 6

- b. To test the store's **Water Hardness** using **TDS**, use the following steps:

- i. Using the remaining test water in the **Small McDonald's Paper Cup**, follow the instructions included with the **HM Digital TDS-3 Meter** to measure the **TDS** of the water in Parts Per Million (PPM) <Figure 6>. Record the result in the space provided at the top of the **PM Check List**.



Fig. 7



Fig. 8

- c. For the readings to be in spec, they must be between 1-5 GPG for **Temporary Hardness** and 25-100 PPM for **TDS**. If the readings are within spec, then no further action is required.

- d. If the readings are out of spec (above either 5 GPG or 100 PPM), then 2 additional samples must be taken and recorded at the top of the **PM Check List**.



Fig. 9



Fig. 10

- i. Using the processes detailed in steps b and c, test the water at the **Espresso Sample Port** of the **RO System <Figure 7>**. This port is generally found at the upper left of the **RO System** and can be open via **Ball Valve**. The measurements in **GPG** and **TDS** must be recorded in the spaces provided at the top of the **PM Check List** as well.
- ii. Using the processes detailed in steps b and c, test the **Raw City Water** from the hand sink <Figure 8>. These sinks are generally found at the rear of the building past the grills. The measurements in **GPG** and **TDS** must be recorded in the spaces provided at the top of the **PM Check List** as well.

NOTE - IF THE WATER WAS FOUND TO BE OUT OF SPEC AND THE DATA FOR ALL 3 TEST LOCATIONS IS NOT FOUND AT THE TOP OF THE PM CHECK LIST, THEN THE WORK ORDER CANNOT BE PROCESSED.

- 4. Locate the **Serial Number** and record at the top of the **PM Check List**
 - a. The Serial Number can be found on the internal machine chassis as well as on major components throughout the Sinfonia FSA:
 - i. On a sticker on to the inside of the **Grounds Container Door** or behind the **Grounds Container <Figure 9>**.
 - ii. At the top left of the front of the machine underneath the **Display Panel <Figure 10>**.

First Steps Continued

5. Inspect the **Coffee Outlet** for damage and replace **Foamer Head O-Rings** and **Steam Coupler Inner Check Valve**.
 - a. Remove the **Coffee Outlet** by depressing the lock tab with your thumb and pulling away from the machine <Figure 11>.
 - b. Check **Coffee Outlet** for warping or cracking.
 - i. If damage is found, speak with **Coffee Responsible (US)** or **McCafé Coordinator (CANADA)** and the Manager on duty about proper cleaning and care of Coffee Outlet. Replace if necessary and bill to store.
 - c. Remove the **Foamer Head** from the **Outlet Couplers** <Figure 12>.
 - d. Locate the **Outlet Couplers (Foamer and Coffee)** and replace **all 4 O-Rings** with those of matching size from the **PM Kit** <Figure 13>.
 - e. Locate the **Steam Outlet Coupler (Center)** and remove the **Casing** by rotating counterclockwise. Replace the **Steam Coupler Inner Check Valve** with a new one from the **PM Kit**. Replace the **Steam Outlet Coupler Casing** by rotating clockwise <Figure 14>.
 - f. Locate the **White Check Valve** on the **Foamer Head**. Remove from the **Foamer** and replace the **O-Rings** with new ones from the **PM Kit**, then replace in the Foamer <Figure 15>.
 - g. Locate the **Splitter** and remove from the **Foamer Head**. Replace the **Splitter O-Ring** with one from the **PM Kit** and replace the **Splitter** into the **Foamer Head** <Figure 16>.
 - h. Replace the **Foamer Head** onto the **Output Couplers**.
 - i. Replace **Coffee Outlet** back onto the front of the machine.
6. Begin a cleaning cycle.
 - a. Locate **Franke 3 Compartment Container, Milk Cleaner, Coffee Cleaner Tablets** and **Cleaning Brush Set** <Figure 17>.
 - b. Refer to most current **McDonald's Cleaning Instructions** to run daily cleaning on coffee machine.

NOTE - FRANKE MILK CLEANER AND FRANKE COFFEE CLEANER IS TO BE SUPPLIED BY THE SERVICE PROVIDER FOR THIS CLEANING.



Fig. 11



Fig. 12



Fig. 13

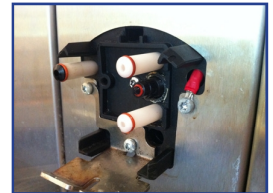

Fig. 14



Fig. 15



Fig. 16



Fig. 17

Tasks While Cleaning Cycle is Running (13 min)

- Torx T20 Driver

- None

1. Unfasten and remove **Left and Right Side Panels** and **Front Cup Plate** from machine.
 - a. Remove **Cup Frame** from **Cup Frame Adaptors** on top of the machine <Figure 1>.
 - b. Using a **Torx T20 Driver**, remove the screws from the **Cup Frame Adaptors** place the **Screws and Cup Frame Adaptors** off to side for later use.
 - c. Remove the **Left and Right Side Panels** by lifting each panel gently from underneath and tipping the frame outward (away from machine) <Figure 2>.
 - d. Remove the **Tablet Chute** by applying pressure to the left and right sides and pulling upward, set aside for later use <Figure 3>.
 - e. Using a **Torx T20 Driver**, remove the **Front Cup Plate** by loosening the **Screws** underneath the **Display Panel** <Figure 4>.



Fig. 1



Fig. 2



Fig. 3



Fig. 4

2. Inspect the **Heating Element Gaskets** for corrosion or build up.

NOTE - THESE STEPS EXPOSE THE TECHNICIAN TO HIGH VOLTAGE LEVELS, NECESSARY SAFETY STEPS SHOULD BE TAKEN TO AVOID ELECTROCUTION.

- a. While viewing the **Boilers** from right side of the machine, inspect the **Heating Element Gaskets** for signs of water leakage or excessive calcium build-up <Figure 5>.
 - b. If signs of water leakage or excessive calcium build-up exist, open separate **Work Order** and replace **Heating Element Gasket**.
3. Visually inspect machine for any sign of scale or wetness that would indicate a leak and speak with a **Franke Call Center Specialist** if repairs must be done.



Fig. 5

Brew Area Maintenance (10 min)

- Franke Coffee Cleaner Tablet
- Sanitized Towel

- Upper Piston O-Ring

1. Remove and clean the **Upper Piston**.
 - a. Loosen the **Thumb Screw** for the **Upper Piston** <Figure 1>.
 - b. Remove **Coffee Line** from **Upper Piston** <Figure 2>.
 - c. Remove the **Clamp Ring** from the **Upper Piston** by placing palm over surface and rotating counterclockwise <Figure 3>.
 - d. Remove the **Upper Piston Sieve** and discard the Upper Piston O-Ring.
 - e. Mix a **Franke Coffee Cleaner Tablet** into a ½ Liter of warm water and soak all the **Upper Piston** parts for 5 minutes <Figure 4>.
2. Clean **Grounds Container Compartment** with a **Sanitized Towel**.
3. Clean the **Brew Chamber** and **Ground Coffee Slide** with a **Sanitized Towel** <Figure 5>.
 - a. Reach through **Grounds Container Compartment** to the **Brew Unit** and clean residual grounds and oils from the **Brewing Chamber** area.
4. Reassemble and replace the **Upper Piston**.
 - a. Remove the **Upper Piston Parts** from the **Franke Coffee Cleaner** mixture and rinse thoroughly with warm water.
 - b. Place **Upper Piston Sieve** in centered position on **Upper Piston**, ensuring that the side with the rough surface is facing down downward.
 - c. Replace the **Clamp Ring** by placing it over the **Sieve** and rotating clockwise.
 - d. Be careful that the **Upper Piston Sieve** stays centered while the **Clamp Ring** is tightened.
 - e. Place new **Upper Piston O-Ring** on **Upper Piston** <Figure 6>.
 - f. Replace the **Upper Piston** into the **Brew Unit** and tighten the **Thumb Screw** by rotating clockwise.
NOTE -TIGHTEN FIRMLY, THEN LOOSEN ONE HALF TURN BY ROTATING COUNTERCLOCKWISE.

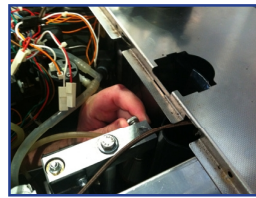

Fig. 1



Fig. 2



Fig. 3



Fig. 4

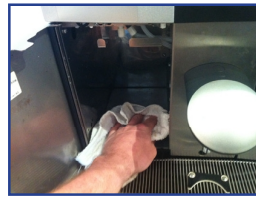

Fig. 5



Fig. 6

Replace Tubing (4 min)

- Side Cutters

- Silicone Tubing

1. To replace a piece of tubing, complete the following steps:
 - i. Disconnect the old piece of **Silicone Tubing** from both connection points.
 - ii. Cut a new length of **Silicone Tubing** to match the old one.
 - iii. Discard the old length of **Silicone Tubing**.
 - iv. Reconnect the new length of **Silicone Tubing** to its previous connection points.

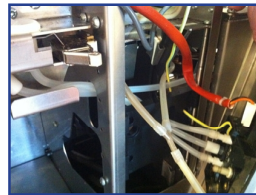

Fig. 1

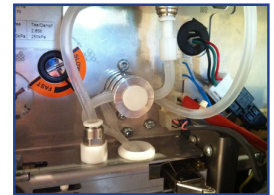

Fig. 2

2. Obtain a new length of **Silicone Tubing** from the **PM Kit** and replace the following tubing connections:
 - a. From the **Upper Piston Nipple** to the **Coffee Outlet Y-Distributor** <Figure 1>.
 - b. From the **Coffee Outlet Y-Distributor** to the **Coffee Outlet** <Figure 1>.
 - c. From the **Steam Connection** to **Pinch Valve Y-Distributor** <Figure 2>.
 - d. From the **Air Orifice** to **Pinch Valve Y-Distributor** <Figure 2>.
 - e. Replace the **Silicone Tubing** between the **Bulk Milk MUT** and the **Refrigerator** <Figure 3>.



Fig. 3

NOTE - THIS STEP WILL REQUIRE REMOVAL OF THE GREY HOSE FROM BEHIND THE RIGHT FRONT PANEL OF THE MACHINE IN ORDER TO INSERT THE NEW TUBING THROUGH THE HOSE.

Machine Lubrication (1 min)

- Franke Spindle Lube
- Clean Dry Towel

- None

1. Lube the **Threaded Spindle** of the **Brew Unit** with 5 drops of **Franke Spindle Lube**.

- a. Locate the Threaded Spindle through the top of the machine <Figure 1>.
- b. Use a **Clean Dry Towel** to remove as much of the previous **Franke Spindle Lube** as possible from the **Threaded Spindle**.
- c. Using **Franke Spindle Lube**, place 5 drops onto the **Threaded Spindle** <Figure 2>.

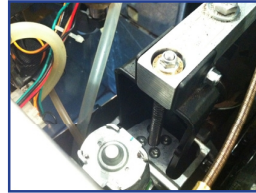

Fig. 1

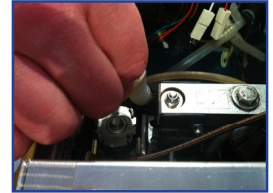

Fig. 2

NOTE - SPINDLE OIL WILL DISTRIBUTE ITSELF THROUGHOUT THE THREADS AS THE BREW UNIT OPERATES.

2. Verify the correct operation of the **Grounds Bin Door Latch** by opening and closing the **Grounds Container Door** <Figure 3>.
 - a. If any unnecessary resistance to movement or creaking noises occur during testing, lube the catch mechanism with 2 drops of **Franke Spindle Lube**.
 - b. Retest the door latch 3-5 times to verify correct operation. If the problem is not resolved, open a new **Work Order** and replace the **Grounds Bin Door Latch**.



Fig. 3

Milk System Maintenance (13 min)

- Sanitized Towel
- Torx T20 Driver
- Franke 3 Compartment Cleaning Container
- Franke Milk Cleaner

- Milk Pickup Silicone Tubing
- Seal Cone
- Spring to Milk System
- Check Valve Silicone Tubing

1. Clean the **Check Valves** on both **Milk Pumps (US and CANADA)** and replace the **Seal Cones** and **Springs to Milk System**.

- Completely disconnect the **Bulk Milk MUT** prior to maintenance.
 - (US Only)** Remove the Milk Pickup Tubes from the 2.5 Gallon Milk Bags.
 - (CANADA Only)** Compress the Milk Line Clips so that the 2.5 Gallon Milk Bags will not leak during maintenance.
 - (CANADA Only)** Remove the **Milk Bag Lines** from the **Barbed Pick-Up Tube Elbows**.
- Place **Milk Pick-Up Tubes** on **Sanitized Towel** <Figure 1>.
- Disconnect the **Milk** and **Steam Lines** from the **Bulk Milk MUT** at the **Quick Disconnects** <Figure 2>.
- Disconnect the **Cannon Plugs** on the top side of the **Bulk Milk MUT** <Figure 3>.



Fig. 1



Fig. 2



Fig. 3



Fig. 4

- Position the **Bulk Milk MUT** so the **Back Plate** is facing upward.
- Using a **Torx T20 Driver**, remove the two **Holding Screws** from the **Back Plate** <Figure 4>.
- Remove **Silicone Tubing** from both **Check Valves Housings** <Figure 5>.
- Unfasten and remove the **Check Valve Assemblies** from the **Milk Pumps** by rotating counterclockwise.



Fig. 5

Milk System Maintenance **Continued**

f. The **Check Valve Assembly** should include the following parts **<Figure 6>**:

- i. Black XFMS Connector**
- ii. O-Ring 4x1 mm**
- iii. Body for Double Safety Valve**
- iv. 2 x Seal Cone**
- v. Spring to Milk System**
- vi. O-Ring D=8.73 x 1.78 mm**

NOTE - DISCARD THE SEAL CONES AND SPRINGS TO MILK SYSTEM AND REPLACE WITH NEW ONES FROM THE PM KIT.



Fig. 6



Fig. 7

g. Fill one compartment of the **Franke 3 Compartment Cleaning Container** with 60 ml **Franke Milk Cleaner**, then fill the rest of the chamber with warm water **<Figure 7>**.

h. Soak **Check Valve Assembly** parts in this solution for 5-10 minutes to remove milk stone.



Fig. 8

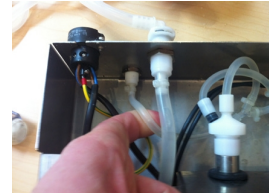

Fig. 9

2. Replace the **Milk Pickup Silicone Tubing**.

a. **(SEE STEP 1 OF “REPLACE TUBING” SECTION FOR REFERENCE)** Using **Milk Pickup Silicone Tubing** from the **PM Kit**, replace the old **Pickup Lines <Figure 8>**.

3. Reassemble the **Bulk Milk MUT (US and CANADA)**

- a. Remove **Check Valve Assembly** parts from **Franke Milk Cleaner** solution and rinse thoroughly with warm water.
- b. Reassemble **Check Valve Assemblies**.

NOTE - FOR PURPOSES OF PROPER WEAR OF THE SEAL CONES, THE SEAL CONE WITH THE SLIGHTLY ROUNDED TIP MUST BE PLACED FACING THE MILK PUMP OUTLET AS IT WAS PRIOR TO THE CLEANING.

c. Fasten **Check Valve Assemblies** to **Milk Pumps** by rotating clockwise.

d. **(SEE STEP 1 OF “REPLACE TUBING” SECTION FOR REFERENCE)** Using **Check Valve Silicone Tubing** from the **PM Kit**, replace the following lines:

- i. From the **Black XFMS Speed Connector** to the **Milk Outlet Y-Distributor <Figure 9>**.
- ii. From the **Check Valve Housing** to the **Steam Inlet Y-Distributor <Figure 9>**.
- iii. From the **Y-Distributors** to the **Quick Fittings <Figure 9>**.

e. Reassemble **Bulk Milk MUT**.

- i. Replace **Back Plate** of the **Bulk Milk MUT**.
- ii. Using a **Torx T20 Driver**, replace the two **Holding Screws**.
- iii. Reconnect the Cannon Plugs on the top side of the Bag Milk MUT.

NOTE - CANNON PLUGS ARE KEYED TO FIT INTO ONE OF THE TWO CONNECTORS ON THE BAG MILK MUT AND CAN BE CONNECTED BY ADJOINING AND ROTATING CLOCKWISE.

iv. (CANADA Only) Ensure that the **Red** and **Blue Zip Ties** are on the lines for the 2 % and Skim milk types, respectively.

v. Reconnect **Milk** and **Steam Lines** to the **Bulk Milk MUT** at the **Quick Disconnects**.

vi. Reconnect the **Milk Pickup Tubes** to the **2.5 Gallon Milk Bags**.

Electrical Confirmation (5 min)

- Multimeter
- Torx T20 Driver

- 2 x Heater Relay

1. Use a **Multimeter** to inspect wall voltage available for machine and record in the space provided at top of **PM Check List**.

- a. Unplug coffee machine from wall power and use the **Multimeter** to measure the AC Voltage between the ports on the wall outlet <Figure 1>.

- i. With 3 ports per outlet, we can label each port A, B and C respectively
- ii. The voltage between two sets of these ports will be approximately 120 VAC, while the voltage between the remaining set of ports will be approximately 208 VAC

EXAMPLE: A-B = 120 VAC, B-C = 120 VAC, C-A = 208 VAC

- iii. Using the larger voltage value (C-A in the example), record the wall voltage in the space provided at the top of the **PM Check List**.

NOTE - INSUFFICIENT TRAINING IN ELECTRICAL SYSTEMS AND SURROUNDING CONDITIONS CAN RESULT IN SERIOUS BODILY HARM WHEN CONDUCTING THIS STEP OF THE WORK INSTRUCTION.

2. Replace the **Heater Relays**.

- a. Locate the **Heater Relays** on the right side of the machine in front of the **Power Print Board**.
- b. Replace with new **Relays** from the **PM Kit**.

NOTE - PAY CAREFUL ATTENTION THAT THE CONNECTIONS ON THE UNDERSIDE OF THE HEATER RELAY ARE KEYED PROPERLY TO FIT BACK INTO THE GROMMET PRIOR TO APPLYING DOWNWARD PRESSURE.

3. Check the **Power Print Board** for correct connection points.

- a. Locate the **Power Print Board** on the right side of the coffee machine behind the **Relays** <Figure 2>.
- b. On the **Power Print Board**, locate the X2_200V and X2_230V prongs at the lower right side of the Power Print Board.
- c. If the voltage is measured from the wall outlet between 216-240 VAC, check that the **Transformer Control Wire** is connected to the X2_230V prong.
- d. If the voltage is measured from the wall outlet between 200-215 VAC, check that the **Transformer Control Wire** is connected to the X2_200V prong.

4. Replace **Left** and **Right Side Panels**, **Front Cup Plate** and **Cup Frame** back on machine and fasten properly.

- a. Place **Front Cup Plate** back on top of machine. Using a **Torx T20 Driver**, tighten the two **Screws** behind the **Display Front Panel** to hold the **Front Cup Plate** in place.
- b. Place the **Left** and **Right Side Panels** back onto **Machine**.
- c. Using a **Torx T20 Driver**, secure the **Cup Frame Adapters** to the top of the **Machine** in order to secure the **Left** and **Right Side Panels**.
- d. Replace the **Cup Frame** into the **Cup Frame Adapters**.

5. Plug the **Machine** back into wall power.

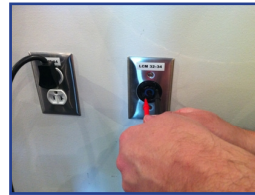

Fig. 1

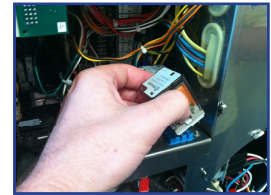

Fig. 2

Operational Checks and Final Customer Services (53 min)

- Install Card
- Gram Scale
- McDonalds Drink Cups (all sizes)
- Coffee Beans
- 200 ml Graduated Cylinder
- Digital Thermometer
- Whole and Nonfat Milk
- Laptop with Windows XP SP2 or above and USB 2.0 Port

- Service Tool FSA 1.3.0 or higher
- Franke USB-to-Serial Converter (320713)
- USB Cable (A-to-B connection points)
- Black Sharpie Marker

- None

1. Power on the machine.
 - a. Press (and hold) **“Power”** button on **Front Display Panel** for 3-5 seconds.
 - b. The **Front Display Panel** backlight will turn on and the drink machine will begin its startup procedure.



Fig. 1

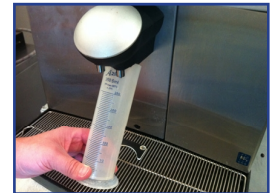

Fig. 2

2. Perform the calibration procedure for both **Grinders**.
 - a. Press on the top right of the **Grounds Container Door** until it clicks to open the door.
 - b. Remove the **Grounds Container** from the **Grounds Container Compartment**.
 - c. Locate the **Gram Scale** and place on a flat, level surface .
 - d. Place a **Small Paper Cup** on top of **Gram Scale** and zero out the meter **<Figure 1>**.
 - e. Insert **Install Card** into machine to enter the **Install Menu**.
 - f. The following menu path can be used to calibrate the **Grinders**:
 - i. **Grinder Calibration: 1 Setup - 15 Calibration - 1 Mills** - (Select the Left Mill Value and adjust)
 - g. Quickly tap the **“Clean”** button twice to run the calibration cycle for the selected grinder, holding the cup at the bottom of the **Grounds Chute** to catch the dispensed grounds.
 - h. On the first dispense is complete, check that the grounds are slightly less coarse than sand, then dispose of the grounds from the cup.
 - i. Quickly tap the **“Clean”** button twice again to run a new calibration cycle.
 - j. After the second dispensing, record the weight (in grams) from the **Gram Scale** and enter the new value into the setup menu.

NOTE - IT IS USUALLY BEST TO USE OF AVERAGE OF 3-5 SAMPLES FOR A MORE ACCURATE CALIBRATION VALUE.
 - k. Select the **“Save”** option on the display menu once the grinder calibration is complete.
 - l. Re-enter the grinder calibration menu and select **Left Mill** in the menu and repeat the calibrating process.
 - m. Select the **“Save”** option on the menu once the grinder calibration is complete.
3. Ensure that the **Espresso Shot** meets the **McDonalds Standard**.
 - a. Note: McDonalds US standard for shot times is **10s** (the grinder may need some small adjustment to match this standard).

Operational Checks and Final Customer Services **Continued**

4. Perform the calibration procedure for both **Milk Pumps**.
 - a. On the install menu, select the **“Back”** option until the top of the menu chain is reached.
 - b. The following menu path can be used to calibrate the **Milk Pumps**:
 - i. 1 Setup → 15 Calibration → 2 Milkpumps → (Select a Milk Pump and adjust).
 - c. Follow this process to calibrate each of the **Milk Pumps** (Whole and Nonfat).
 - i. Quickly tap the **“Clean”** button twice to dispense milk from the **Foamer Head Outlet**.
 - ii. Locate a **200ml Graduated Cylinder** and hold it underneath the **Foamer Head Outlet** <Figure 2>.
 - iii. Record the volume of milk dispensed (not foam) and enter the new value into the calibration menu for the **Milk Pump** that was tested.
 - iv. Dispose of milk in the kitchen sink and rinse the **200ml Graduated Cylinder** thoroughly.

5. Ensure all drink fill levels and temperatures are accurate.
 - a. The **Drink Configuration Menu** for the **US** is demonstrated in <Figure 3> (Whole and Nonfat versions of every drink must be calibrated).
 - b. The **Drink Configuration Menu** for **CANADA** is demonstrated in <Figure 4> (Whole and Nonfat versions of every drink must be calibrated).
 - c. On the Install menu, select the back option until the top of the menu chain is reached.
 - d. To adjust the attributes of a drink, there are 3 parts:
 - i. To select the drink, follow the menu chain: 2 Product Definition → 1 Select Product (Select the product to adjust) → Save
 - ii. To adjust the fill level, follow the menu chain:
 1. 2 Product Definition → 2 Fill Level → Change value of Milk Fill Level (Part 1 = Steamed Milk Volume, Part 2 = Foamed Milk Volume) → Save.

NOTE - NONFAT BUTTON MUST BE SELECTED BEFORE ENTERING FILL LEVEL MENU IN ORDER TO SEE NON-FAT VALUES.

- iii. To adjust the temperature, follow the menu chain: 2 Product Definition → 8 Temperatures → Change value of Temperatures for Milk Part 1 and Part 2 → Save.

Screen 1		Screen 2	
1	Small Cappuccino	5	Medium Cappuccino
2	Small Latte	6	Medium Latte
3	Small Mocha	7	Medium Mocha
4	Small Iced Latte/Mocha	8	Medium Iced Latte/Mocha
Screen 3		Screen 4	
9	Large Cappuccino	13	Sample Cappuccino
10	Large Latte	14	Sample Latte
11	Large Mocha	15	Sample Mocha
12	Large Iced Latte/Mocha	16	Sample Iced Latte/Mocha
Screen 5		Screen 6	
17	Small Hot Chocolate	21	Medium Hot Chocolate
18	Small Cold Chocolate	22	Medium Cold Chocolate
19	Small Special Hot	23	Medium Special Hot
20	Small Special Cold	24	Medium Special Cold
Screen 7		Screen 8	
25	Large Hot Chocolate	29	Empty
26	Large Cold Chocolate	30	Empty
27	Large Special Hot	31	Add Milk
28	Large Special Cold	32	Prime Milk

Fig. 3

Screen 1		Screen 2	
1	Small Cappuccino	5	Medium Cappuccino
2	Small Latte	6	Medium Latte
3	Small Mocha	7	Medium Mocha
4	Small Hot Chocolate	8	Medium Hot Chocolate
Screen 3		Screen 4	
9	Large Cappuccino	13	Add Foam
10	Large Latte	14	Add Hot Milk
11	Large Mocha	15	Add Cold Milk
12	Large Hot Chocolate	16	Prime Milk
Screen 5		Screen 6	
17	Long Espresso	21	Empty
18	Small Iced Latte	22	Medium Iced Latte
19	Small Iced Mocha	23	Medium Iced Mocha
20	Small Americano	24	Medium Americano
Screen 7		Screen 8	
25	Empty	29	Empty
26	Large Iced Latte	30	Empty
27	Large Iced Mocha	31	Empty
28	Large Americano	32	Empty

Fig. 4

Operational Checks and Final Customer Services **Continued**

- e. For every size of every drink in Whole and Nonfat milk:
 - i. Run a test drink.
 - ii. Make adjustments to the menu settings for the drink as listed in step d.
 - iii. Run another test drink to verify that the changes were effective.

NOTE - AFTER THE FIRST 2-3 DRINKS ARE CALIBRATED, IT CAN BE ASSUMED THAT THE REST OF THE DRINKS ON THE MENU WILL USE SIMILAR TEMPERATURE SETTINGS FOR WHOLE AND NONFAT MILK PARTS 1 AND 2, THOUGH THESE TEMPERATURES MUST STILL BE VERIFIED TO CONSIDER THE DRINK CALIBRATED.

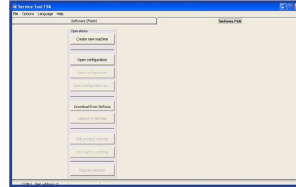

Fig. 5

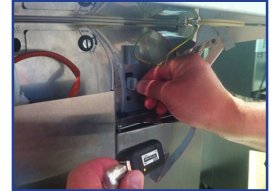

Fig. 6

6. Power off the machine.
 - a. Press (and hold) **“Power”** button on **Front Display Panel** for 3-5 seconds.
 - b. The **Front Display Panel** will darken and the drink menu will disappear, signaling that the machine has turned off.
7. Set up **Service Tool FSA** for communication with the machine.
 - a. Locate your **Laptop** (pre-loaded with **Service Tool FSA**) and the **Franke USB to Serial Adaptor**.
 - b. Start up the **Service Tool FSA Software** <Figure 5>.
 - c. Press on the top right of the **Grounds Container Door** until it clicks to open the door.
 - d. Using an index finger, open the **Front Display Panel** by throwing the lever at the lower left corner of the display.
 - e. Disconnect the **Small Ribbon Cable** from the machine.
 - f. Connect the **USB to Serial Adaptor** to the machine <Figure 6>.
8. Download **Configuration** and send in to tech support with any additional close-out information.
 - a. In the right tab, labeled **“Sinfonia FSA”**, of **Service Tool FSA**, press the **“Download from Sinfonia”** button at the left center of the window <Figure 7>.
 - b. Press the **“Save configuration as...”** button to save the file (Name the file as **McD - store number - date**)
 - c. Send the modified configuration file to **fs-coffeesupport.us@Franke.com** with any additional close-out information.
9. Cleanup.
 - a. Close **Service Tool FSA** and put aside the **Laptop** for later use.
 - b. Remove the **USB Cable** and the **USB to Serial Adaptor** from the machine and set aside for later use.
 - c. Close the **Front Display Panel** and the **Grounds Container Door**.
10. Power on the machine.
 - a. Press (and hold) **“Power”** button on **Front Display Panel** for 3-5 seconds.
 - b. The **Front Display Panel** backlight will turn on and the **Sinfonia FSA** will begin its startup procedure.
11. Update the **PM Log Sticker** on inside of **Grounds Container Door**.
 - a. Locate the **Sticker** on the inside of the **Grounds Container Door** and update it using **Black Sharpie Marker** (Enter the date and your initials in the listing for the PM that was performed).
12. Ensure that the location has an adequate supply of **Franke Milk Cleaner** and **Franke Coffee Cleaner**.
 - a. Assist the store manager in ordering more if necessary.

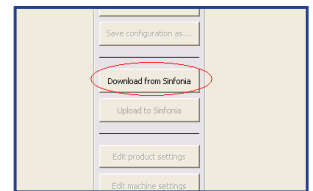

Fig. 7

NOTE - 1 FULL BOTTLE WILL LAST TWO WEEKS AT 1 CLEANING PER DAY

Franke Coffee Systems, N.A.
800 Aviation Parkway
Smyrna, TN 37167
USA
Tel +1 800 310 5710
Email: info.fcsna@franke.com
www.franke-cs.com



COFFEE
SYSTEMS

© 2010 Franke Coffee Systems, N.A.
This document is the confidential and proprietary property of Franke Coffee Systems, N.A and shall not be reproduced in any form of media without the expressed written permission of a Franke Coffee Systems, N.A representative.

Due to continuous product development, Franke Coffee Systems, N.A reserves the right to make changes in design and specifications without prior notice.

Under license of NIRO-Plan AG, Switzerland

Printed in U.S.A

-PM 2 v13 WI-REV1.0

Franke Sinfonia FSA

Technical Training Manual

Troubleshooting / Error Codes – Chapter 4



Franke Coffee Systems
800 Aviation Parkway
Smyrna, TN 37167
(615) 462-4000

Change log

Date	Changes	Author	Change No.	ID
2009-07-20	New Manual Concept	MPH		

Publisher:

Franke Kaffeemaschinen AG
 P.O. Box 235
 CH-4663 Aarburg
 Switzerland

www.franke-cs.com

Table of Contents

Change log	2
Table of Contents	3
Display Messages.....	4
Troubleshooting Guide	6
Error Messages on Display	6
Error Codes History (not shown in display)	17
CPU Board (IFL) and Flash Memory (XIFL).....	19
Changing the CPU Board.....	20
Changing the Flash Memory Print.....	21
Reprogram CPU Flash Memory	22

Display Messages

Following is a list of the more common display messages. A complete list of the error code messages can be found in the troubleshooting section of this manual.

This message is displayed for a few seconds when the machine is initially turned on.

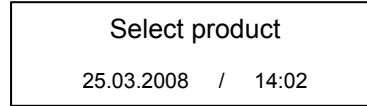

A plus sign on the left hand side of the display indicates that the boiler is filling with water.

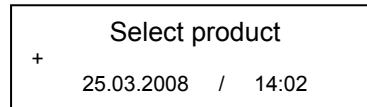

The Asterisk on the right side of the display appears when the coffee heater / steam heater is switched on. Drink production is not possible.

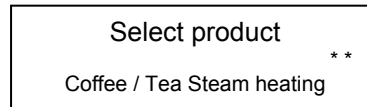

The machine is now ready for drink production.

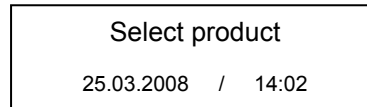

The coffee outlet is not installed or not installed correctly while the machine is operational, the display will alternately flash the "missing cof. outlet" message followed by "Code 2".

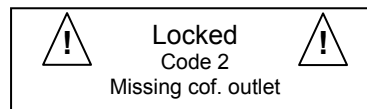

When the grounds chute door is opened while the machine is operational, the display will alternately flash the "Door open" message followed by "Code 3".

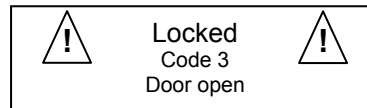

When the front control panel is opened while the machine is operational, the display will alternately flash the "front panel open" message followed by "Code 4".

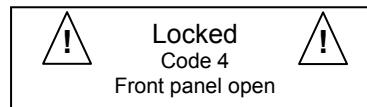

When the pre-programmed number of cycles has been produced, the machine will prompt the user to run a cleaning cycle. This can also be programmed to a specific time of day.

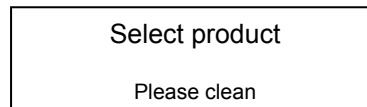

If the end user has not cleaned the machine before the pre-programmed amount of time before lock-out, the display will continue to show the "Please clean" message along with the Locked message. If a product is selected, an audible beep will be heard. Drink production is locked.

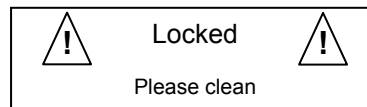



When there is a blockage or restriction in the water flow of the brewing circuit, the display will alternately flash the “Flowmeter” message, followed by “Code 110.”

Select product
Flowmeter / Code 110

The grounds container is 10 products from being full and should be emptied soon.

Select product
Empty drawer

If the end user does not empty the grounds container, the display will continue to display the “Empty drawer” message followed by “Code 150”. Drink production is locked.

 Locked 
Empty drawer / Code 150

If the steam boiler does not fill with water within a set time, the display will alternately flash the “Steam supply” message, followed by “Code 32.”

Select product
Steam supply / Code 32

If either boiler does not reach operational temperature/pressure within a set time, the display will alternately flash the “Heater timeout” message, followed by the appropriate code.

Select product
Heater timeout / Code 14 or 19

If the piston motor is not operating properly, the display will alternately flash the “Motor timeout” message, followed by the appropriate code.

Select product
Motor timeout / Code 40-46

If the milk container runs empty, the display will show the “No Milk” message, followed by an audible beep if a milk product is selected. You can generally make approximately 5 more drinks before the machine locks you out of production, evident by an audible beep if a milk product is selected.

Select product
No milk

If the any bean hopper runs out of coffee, the display will alternately flash the “No beans” message followed by “Code 120.”

Select product
No beans

If the chip card is inserted improperly or the chip card or reader is damaged, the display will show the “Read chipcard” message followed by “Code 50.” Ensure the card is inserted properly, with the gold chip facing the machine.

Select product
Read chipcard

If a chipcard that is not associated with the Sinfonia is inserted into the card reader, the display will show the “Chipcard ident” message followed by the appropriate code.

Select product
Chipcard ident

Troubleshooting Guide

Error Messages on Display

Symptoms	Possible Reasons	Check	Solution
Error code 1 External RAM (Flash Card)	External RAM defective	Check to see that the external RAM is installed properly.	Replace external RAM if found to be faulty.
Error code 2 Missing coffee outlet <i>All functions are disabled if the outlet is missing</i>	Coffee outlet not installed properly and the microswitch is not closing.	Ensure the outlet is installed properly. The plastic tab on the back of the coffee outlet should actuate the microswitch when installed.	Push on the top of the outlet to make sure the switch is being activated. Replace the outlet if the plastic tab is damaged or missing.
	Microswitch signal is faulty, wires damaged.	Troubleshoot the microswitch for proper operation.	Replace the switch if faulty.
Error code 3 Door open <i>All functions are disabled if the grounds door is open</i>	Grounds door not closed. Microswitch is not closing.	Ensure the door is closed properly. The metal tab at the top of the door should actuate the microswitch when closed.	Re-align the metal tab if needed. Re-align the microswitch if needed.
	Microswitch signal is faulty, wires damaged.	Troubleshoot the microswitch for proper operation.	Replace the microswitch if faulty.
Error code 4 Front panel open <i>All functions are disabled if the front panel is open</i>	Front panel not closed. Microswitch is not closing.	Ensure the front panel is closed properly. The tab on the panel should actuate the microswitch when closed.	Re-align the microswitch if needed.
	Microswitch signal is faulty, wires damaged.	Troubleshoot the microswitch for proper operation.	Replace the microswitch if faulty.
Error code 10 Temperature sensor	Wiring damaged causing a short circuit.	Follow the wiring checking for damage	Replace/repair damaged wiring.
	Coffee boiler thermostat is short-circuited/faulty.		Replace the thermostat.

Symptoms	Possible Reasons	Check	Solution
Error code 11 Temperature sensor	Coffee boiler thermostat is not connected properly, wiring damaged causing an open circuit.	Ensure the 2-pin male connector (black wires) is installed securely to the 2-pin female connector (white wires). This connector is located behind the rear right hand panel.	Push the connectors together. Replace the pins/wiring if found to be faulty.
	Coffee boiler thermostat is faulty.	Measure resistance – open loop = faulty	Replace thermostat if found to be faulty.
Error code 12 Temp difference <i>No temperature increase in the coffee boiler has been detected after a specific period of time.</i>	Coffee boiler thermostat is faulty or not connected properly.	Ensure the 2-pin male connector (black wires) is installed securely to the 2-pin female connector (white wires). This connector is located behind the rear right hand panel.	Push the connectors together. Replace the pins/wiring if found to be faulty.
	Heating element circuit is faulty.	Check the heating element thermal limiters for a tripped switch.	Reset or replace the thermal limiters.
		Check heater relays for proper operation using your install card in the check outputs parameter.	Replace the heater relays if faulty.
		Check the heating element wiring for damage and proper connection.	Repair damaged wiring.
		Check the heating element for proper operation.	Replace the heater element if found to be faulty.
Error code 13 Overtemperature <i>The water temperature in the coffee boiler exceeded 120°C.</i>	Heating relay stuck in the closed position.	Check the heater relay for sticking due to carbon build-up.	Replace relay if found to be faulty.

Symptoms	Possible Reasons	Check	Solution
Error code 14 Heater timeout <i>The coffee boiler did not reach operational temperature within a specific time.</i>	Heating element circuit is faulty.	Check the heating element thermal limiters for a tripped switch.	Reset or replace the thermal limiters.
		Check heater relays for proper operation using your install card in the check outputs parameter.	Replace the heater relays if faulty.
		Check the heating element wiring for damage and proper connection.	Repair damaged wiring.
		Check the heating element for proper operation.	Replace the heater element if found to be faulty.
Error code 15 Temperature sensor <i>HW boiler</i>	Wiring damaged causing a short circuit.	Follow the wiring checking for damage	Replace/repair damaged wiring.
	HW boiler thermostat is short-circuited/faulty.		Replace the thermostat.
Error code 16 Temperature sensor <i>HW boiler</i>	HW boiler thermostat is not connected properly. Open circuit.	Ensure the 2-pin male connector (black wires) is installed securely to the 2-pin female connector (white wires). This connector is located behind the rear right hand panel.	Push the connectors together. Replace the pins/wiring if found to be faulty. Replace thermostat if found to be faulty.

Symptoms	Possible Reasons	Check	Solution
Error code 17 Temp difference <i>No temperature increase in the HW boiler has been detected after a specific period of time.</i>	HW boiler thermostat is faulty or not connected properly	Ensure the 2-pin male connector (black wires) is installed securely to the 2-pin female connector (white wires). This connector is located behind the rear right hand panel.	Push the connectors together. Replace the pins/wiring if found to be faulty.
	Heating element circuit is faulty	Check the heating element thermal limiters for a tripped switch.	Reset or replace the thermal limiters.
		Check heater relays for proper operation using your install card in the check outputs parameter.	Replace the heater relays if faulty.
		Check the heating element wiring for damage and proper connection.	Repair damaged wiring.
		Check the heating element for proper operation.	Replace the heater element if found to be faulty.
Error code 18 Overtemperature <i>The water temperature in the HW boiler exceeded 120°C.</i>	Heating relay stuck in the closed position.	Check the heater relay for sticking due to carbon build-up.	Replace relay if found to be faulty.
Error code 19 Heater timeout <i>The steam boiler did not reach operational temperature within a specific time.</i>	Heating element circuit is faulty.	Check the heating element thermal limiters for a tripped switch.	Reset or replace the thermal limiters.
		Check heater relays for proper operation using your install card in the check outputs parameter.	Replace the heater relays if faulty.

Symptoms	Possible Reasons	Check	Solution
Error code 19 (continued)		Check the heating element wiring for damage and proper connection.	Repair or replace the damaged wiring.
		Check the heating element for proper operation.	Replace the heater element if found to be faulty.
		Check the pressure switch for proper operation.	Replace the pressure switch if found to be faulty.
Error code 20 Temperature sensor <i>The Autosteam probe is short-circuited/faulty.</i>	Autosteam probe is not returning the correct value to the CPU. Value too low.	Check the wiring from the Autosteam probe to the CPU board for damage or shorting to ground.	If wiring is damaged, replace the Autosteam probe.
Error code 21 Temperature sensor <i>The Autosteam probe is not connected properly.</i>	Autosteam probe is not returning the correct value to the CPU. Value too high. Open circuit.	Check the wiring from the Autosteam probe to the CPU board for damage or open loop. Check the connection of the probe on the CPU board.	If wiring is damaged, replace the Autosteam probe.
Error code 22 Temp difference <i>No temperature increase in the Autosteam probe has been detected after a specific period of time.</i>	Autosteam probe faulty or not connected properly	Ensure the 2-pin male connector (black wires) is installed securely to the 2-pin female connector (white wires). This connector is located behind the rear right hand panel.	Push the connectors together. Replace the pins/wiring if found to be faulty.
Error code 23 Overtemperature <i>The temperature at the Autosteam probe exceeded 120°C.</i>	Autosteam probe is not returning the correct value to the CPU. Value too low. Short circuit.	Check the wiring from the Autosteam probe to the CPU board for damage or open loop. Check the connection of the probe on the CPU board.	If wiring is damaged, replace the Autosteam probe.

Symptoms	Possible Reasons	Check	Solution
Error code 30 Water feed <i>The coffee boiler did not fill within 2 minutes.</i>	Water is not reaching the coffee machine.	Ensure the water line is turned ON and the quick-release is connected properly.	Turn on the water. Push the quick-release connectors together.
		Check the water line for kinking/pinching.	Allow for free movement in the water line.
		Check the mains valve for proper operation using the install card in the check outputs parameter.	Replace the mains valve if found to be faulty.
		Check the flowmeter for blockage by removing it and cleaning the inlet and outlet sides.	Replace the flowmeter if found to be faulty.
		Check the inlet elbow on the coffee boiler for blockage.	Replace the inlet elbow if found to be faulty.
Error code 31 Water feed <i>The flowmeter reached 3000 pulses.</i>	Water flow does not stop. Flowmeter continues to send signal to CPU board. Water leak somewhere in the coffee water system.	Check the water system for leakage inside the machine. Check to drip tray for signs of water flow. Check the overpressure release valve water flow.	Repair leak, replace parts as needed.
Error code 32 Steam feed <i>The steam boiler did not fill within 2 minutes.</i>	Water is not reaching the coffee machine.	Ensure the water line is turned ON and the quick-release is connected properly.	Turn on the water. Push the quick-release connectors together.
		Check the water line for kinking/pinching.	Allow for free movement in the water line.
		Check the mains valve for proper operation using the install card in the check outputs parameter.	Replace the mains valve if found to be faulty.
		Check the feeding valve for blockage and proper operation using the install card in the check outputs parameter.	Replace the feeding valve / plunger if found to be faulty.

Symptoms	Possible Reasons	Check	Solution
Error code 32 (continued)		Check the inlet elbow on the steam boiler for blockage.	Replace the inlet elbow if found to be faulty.
Error Code 40 – Motor Timeout <i>brewing motor did not startup within 0.5 seconds of the command (no increase in current). Undefined position.</i>	Faulty wiring on the brew unit.	Check the wiring from the power board to the brew unit for damage and proper connection.	Repair or replace the wiring if found to be damaged.
	Brew unit blocked due to excessive coffee build-up in the brew chamber.	Check the brew chamber for coffee build-up.	Clean the brew unit and re-adjust the coffee chute for proper alignment.
Error Code 41 – Motor Timeout <i>brewing motor was switched on for >30 seconds between home and filling position.</i>	Mechanical binding in the brew unit.	Check the brew unit for proper operation using the install card in the check outputs parameter.	Re-adjust the brew unit if binding occurs. Replace the brew unit if this does not solve the problem.
Error Code 42 – Motor Timeout <i>brewing motor was switched on for >30 seconds while being moved between filling position and brewing.</i>		Check the spindle for proper movement/lubrication.	Lubricate the spindle using the spindle oil (301340).
		Check the increment counter using the test outputs. Check signal from increments counter using test inputs.	Replace the motor if found to be faulty.
Error Code 43 – Motor Timeout <i>brewing motor was switched on for too long during brewing, rinsing or cleaning. Brewing chamber open.</i>			
Error Code 44 – Motor Timeout <i>brewing motor was switched on for >30 seconds while being moved between brewing and filling (re-initializing).</i>			
Error Code 45 – brewing motor timeout moving upwards	Position increments counter not connected or defective.	Check the increment counter using the test outputs. Check signal from increments counter using test inputs.	Replace the motor found to be faulty.
Error Code 46 – brewing motor timeout moving downwards.			

Symptoms	Possible Reasons	Check	Solution
Error code 50 Chipcard read <i>An error occurred while reading the header info.</i>	Chipcard dirty. Chipcard reader dirty.	Check the Chipcard for dirty or damaged chip.	Clean Chipcard and Chipcard reader. Erase Chipcard (except Install Card). Replace Chipcard if found to be faulty.
	Chipcard reader defective.	Check Chipcard reader for possible damage.	Clean Chipcard reader. Replace Chipcard reader if found to be faulty.
Error code 51 Chipcard ident <i>Invalid manufacturer code.</i>	RID is invalid. Card cannot be used for Evolution.		Use correct Chipcard for Evolution
Error code 52 Chipcard ident <i>Invalid manufacturer code.</i>	PIX is invalid. Card cannot be used for Evolution.		Use correct Chipcard for Evolution
Error code 53 Chipcard ident	This type of card is not supported by Evolution.		Use correct Chipcard for Evolution
Error code 54 Chipcard ident <i>An error occurred while reading the data block</i>	Chipcard dirty. Chipcard reader dirty.	Check the Chipcard for dirty or damaged chip.	Clean Chipcard and Chipcard reader. Erase Chipcard (except Install Card). Replace Chipcard if found to be faulty.
	Chipcard reader defective.	Check Chipcard reader for possible damage.	Clean Chipcard reader. Replace Chipcard reader if found to be faulty.

Symptoms	Possible Reasons	Check	Solution
Error code 55 Chipcard ident	The installation number is incorrect.	Check the installation number of the coffee machine with Service Tool.	Use the corresponding Chipcard for this machine. Erase Chipcard (except Install Card).
Error code 56 Chipcard write	The Chipcard is no longer useable, because no more error-counter bits are available (max. 3).	Repeated attempts were made to write an incorrect PSC to the card.	Erase Chipcard. Replace Chipcard if found to be faulty.
Error code 57 Chipcard write <i>A chipcard reader with an incorrect write-protect code is in the reader.</i>	CAUTION! The Chipcard will become unreadable after 8 failed reading, even on a device with the correct code. > Error code 57		
Error code 58 Chipcard write <i>Timeout occurred while writing the card.</i>	Chipcard dirty. Chipcard reader dirty.	Check the Chipcard for dirty or damaged chip.	Clean Chipcard and Chipcard reader. Erase Chipcard (except Install Card). Replace Chipcard if found to be faulty.
Error code 59 Chipcard write <i>A verification error occurred while writing to the card.</i>	Chipcard dirty. Chipcard reader dirty.	Check the Chipcard for dirty or damaged chip.	Clean Chipcard and Chipcard reader. Erase Chipcard (except Install Card). Replace Chipcard if found to be faulty.
Error code 90 Maintenance	Maintenance request.		Perform maintenance and reset counter.
Error code 100 Empty drawer.	Grounds drawer is full.	Check the grounds drawer and empty.	Empty the grounds drawer.

Symptoms	Possible Reasons	Check	Solution
Error code 110 Flowmeter error <i>CPU board is not receiving a signal from the flowmeter.</i>	The flow of water through the brew chamber is restricted.	Check the grinder adjustment.	Turn the grinder adjustment screw to coarse and check the grind weight after the adjustment is done.
		Check the upper piston microsieve for coffee build-up.	Remove the upper piston and clean the microsieve. Replace the sieve if needed.
	Coffee valve is not operating properly.	Check the coffee valve for proper operation using the install card in the check outputs parameter.	Replace the coffee valve if found to be faulty.
	Flowmeter is not operating properly. Blockage inside the flowmeter.	Check the flowmeter for proper operation. Check the flowmeter for blockage by removing it and cleaning the inlet and outlet sides. Check the flowmeter rotor for proper movement.	Replace the flowmeter if found to be faulty.
Error code 120 No beans <i>The upper piston traveled too far into the brew chamber.</i>	Hopper is empty.	Check the hopper to see if it's empty	Refill with fresh coffee beans.
	Coffee beans not sliding down into the grinder.	Check the hopper to see if the beans are sticking to the sides of the hopper.	Clean the hopper to rid of all the coffee oil residue.
	Coffee slide plugged up with coffee grounds.	Check the coffee slide to see if ground coffee is backed-up inside.	Clean out the coffee slide.
	Grinder not operating properly.	Check the grinder for proper operation using the install card in the check outputs parameter.	Clean the grinder burrs, replace the grinder / capacitor if found to be faulty.

Symptoms	Possible Reasons	Check	Solution
Error code 130 Milk empty	Milk container is empty.	Check that the milk container is placed in front of the milk level sensor. Check that the label on the milk jugs is not facing the milk level sensor. Check that the milk container is filled with milk	Place milk container in front of milk level sensor. Re-fill milk container.
Error code 132 Syrup tanks empty	At least one syrup tank is empty.	Check the syrup tanks.	Replace / fill syrup tanks.
Error code 140 Communication	The connection between CCI/CSI – interface is interrupted. Contact Service.	To continue dispensing, switch the accounting system OFF using the Adjust Card.	Call Service.
Error code 150 Empty grounds container	The programmed amount of coffee cakes in the grounds container has been reached.	Check the grounds container. Empty the grounds container when opening the grounds container door.	Empty the grounds container. The counter will be reset when the grounds door is opened. Empty the container before closing the grounds door.
Error code 160 Empty battery	The back-up battery in the CPU Print is missing or empty.	Check back-up battery on CPU Print	Contact Customer Service. DO NOT DISCONNECT SINFONIA from ELECTRICAL MAINS: Settings will be lost!

Error Codes History (not shown in display)

Symptoms	Possible Reasons	Check	Solution
Error code 300 Cold start	A cold start was carried out: The Sinfonia was disconnected from power source and then re-connected.		
Error code 301 Watchdog (CPU)	A watchdog reset was carried out when an invalid state was detected in the control system or a software update was not made.		
Error code 302 Counter deleted	There is no valid counter in RAM or in the Flash module. In this case, all counters were deleted.		
Error code 303 Counter from Flash	There counters in RAM were invalid; the counter status from the Flash module was downloaded to RAM.		
Error code 304 Config. from ROM	No valid machine configuration was present in RAM or the Flash module. The machine was reset to the basic configuration.		
Error code 305 Config. from Flash	The machine configuration in RAM was invalid. The machine configuration was downloaded to RAM.		

Symptoms	Possible Reasons	Check	Solution
Error code 306 Products form RAM	No valid product configuration was present in RAM or the Flash module. All products set to "undefined".		
Error code 307 Products from Flash	The product configuration in Ram was invalid. The product data from Flash module was downloaded to RAM		

CPU Board (IFL) and Flash Memory (XIFL)

The CPU board contains

- The coffee machine software (Version 1.x / 15.xx / 25.xx)
- Coffee Drink Configuration file

Flash Memory contains

- Flash Memory Software
- Back-up of the coffee machine software
- Back-up of the drink configuration file
- All the Graphic Display files
 - Software 1.x in Full Graphic Mode
 - Software 15.xx (S4S)
 - Software 25.xx (FSA)

The Graphic Display files are ONLY in the Flash Memory.

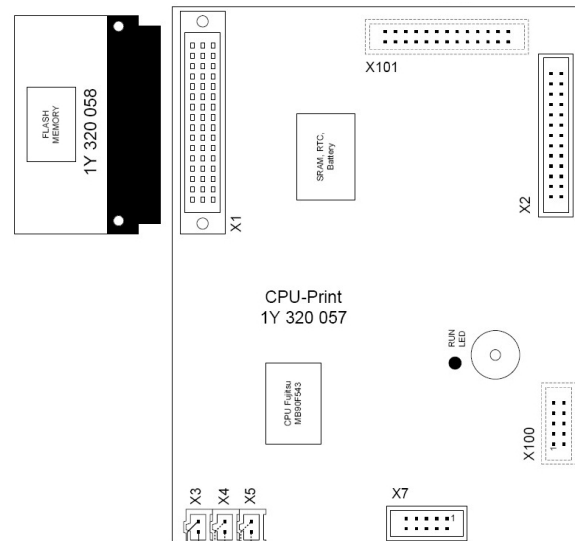

Every time the machine is turned ON, the CPU will pull the information from the Flash Memory and compare it to the information on the CPU board. The coffee machine will prompt the user to either upload the current IFL to XIFL or download XIFL to IFL if any differences are found between the two.

A Back-up of the CPU software and drink configuration files to the Flash Memory is done:

- Every time the coffee machine is turned OFF
- Every time the install card is removed from the card reader
- Every time the adjust card is removed from the card reader
- When you back-up the file using the back-up function in the install-menu
- After every 8 hours of operation

Changing the CPU Board

The CPU board has an external Flash Memory print attached to it. The Flash Memory is used to back up all the machine information, drink configurations and machine software. When replacing the CPU board you must keep the old Flash Memory print and install it on the new CPU board.

Important!

Before changing the CPU board, we recommend you back up the Sinfonia drink configuration file onto your Notebook/PC using the Service Tool FSA.

1. Turn the machine off.
2. Disconnect the machine from the power supply.
3. Exchange the CPU board.
4. Install the Flash Memory print from the old CPU board.
5. Reconnect the machine to the power supply.
6. An acoustic signal occurs.
7. Confirm the request
Download XIFL to IFL
8. An acoustic signal occurs (1 long beep, 2 medium beeps and 2 short beeps)
9. The machine will restart.
10. The download is completed.
11. Turn the machine back on by pushing the power button.

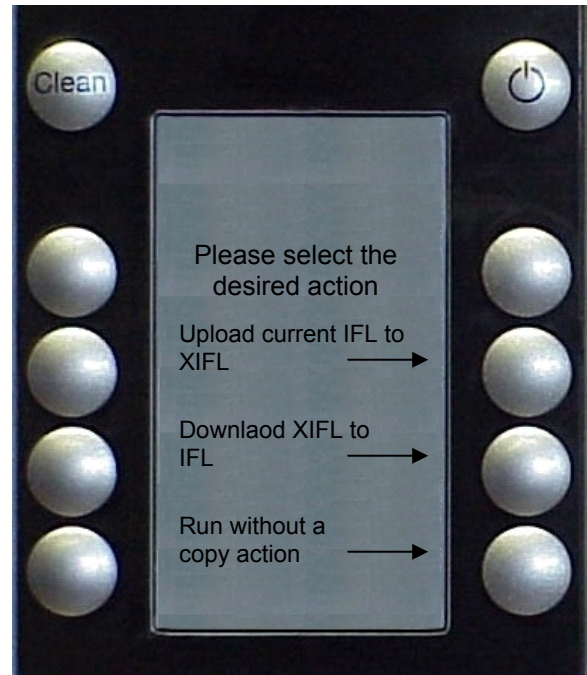

Flash Memory software needs to be installed using the appropriate Service Tool software.

If the download procedure is interrupted, the Flash Memory will be corrupted. The Flash Memory will need to be reflashed with Fujitsu CoreFlashUtility using the Service Tool FSA "Reprogram flash-memory" procedure.

Changing the Flash Memory Print

Before changing the Flash Memory print

- Make sure that you back up the Sinfonia drink configuration file onto your Notebook/PC using the Service Tool.

Important!

*Make sure that you have the newest Sinfonia coffee machine software available for installation.

1. Turn the machine off.
2. Disconnect the machine from the power supply.
3. Exchange the Flash Memory print.
4. Reconnect the machine to the power supply.
5. An acoustic signal occurs.
6. Confirm the request
Upload current IFL to XIFL
7. An acoustic signal occurs (1 long beep, 2 medium beeps and 2 short beeps)
8. The machine will restart.
9. Using the Service Tool, install the newest Sinfonia software.
10. Turn the machine back on by pushing the power button.



Flash Memory software needs to be installed using the appropriate Service Tool software.

If the download procedure is interrupted, the Flash Memory will be corrupted. The Flash Memory will need to be reflashed with Fujitsu CoreFlashUtility using the Service Tool FSA "Reprogram flash-memory" procedure.

Reprogram CPU Flash Memory

Before reprogramming CPU Flash Memory

- Make sure that you back up the Sinfonia drink configuration file onto your Notebook/PC using the Service Tool.

Important!

*Make sure that you have the newest Service Tool FSA software available for installation.

*Make sure that you have the newest Sinfonia FSA coffee machine software available for installation.

After replacing the CPU, it is possible that you will need to reprogram the CPU Flash Memory.

1. Start Service Tool FSA
2. Select Software (Flash) tab
3. Open “Choose software file” window by clicking on the “open file” icon the desired

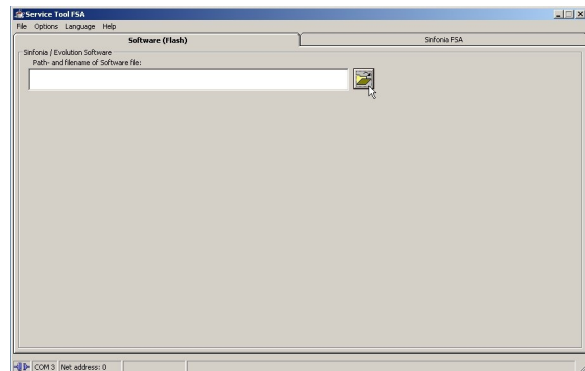

4. Select the correct Sinfonia FSA software file (*.ssw)

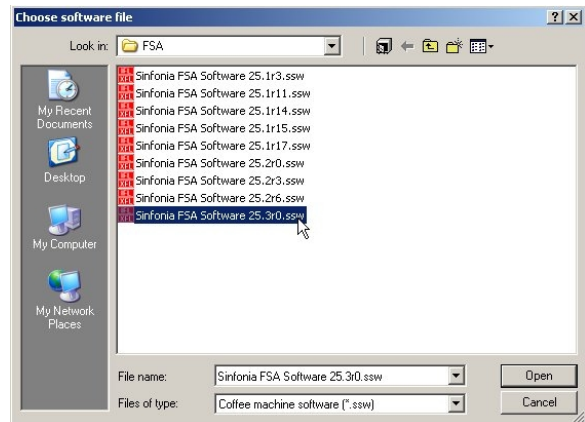

5. Open the software file by clicking on the



6. Select “Options – Reprogram flash-memory on Sinfonia CPU print?”

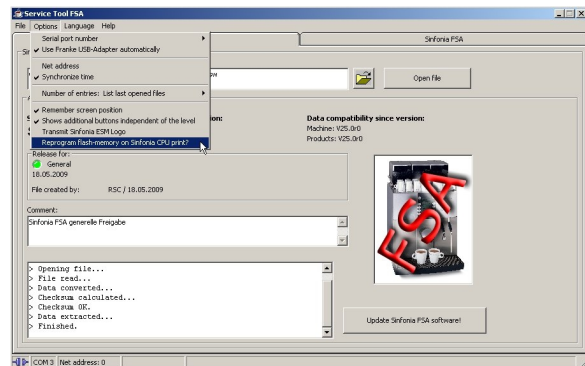

The process will take approx. 15 minutes. DO NOT INTERRUPT THE FLASH PROCESS!

Franke Sinfonia FSA

Technical Training Manual

Programming Instructions – Chapter 6



Franke Coffee Systems
800 Aviation Parkway
Smyrna, TN 37167
(615) 462-4000

Change log

Date	Changes	Author	Change No.	ID
2009-07-20	New Manual Concept	MPH		
2010-02-28	Software changes version 25.03r06	MPH		A
2010-09-28	Software changes version 25.06r12	MPH		B

Publisher:

Franke Kaffeemaschinen AG
 P.O. Box 235
 CH-4663 Aarburg
 Switzerland

www.franke-cs.com

Table of Contents

Change log	2
Table of Contents	3
Programming	6
Inserting the Install Card	6
Programming Navigation.....	6
Entering the PIN Code	7
Install Menu 1 – 2.....	8
Install Menu 3 – 7.....	9
Symbols appearing in the display.....	11
When programming.....	11
1. Set-up	13
1.1 Unit Nr.	13
1.2 Model	14
1.3 Mode	14
1.4 Accounting	15
1.5 Temperatures	15
1.6 Mills	16
1.7 Pressure	16
1.8 Cleaning 1	16
1.9 Cleaning 2	17
1.11 Milk correction	19
1.12 Name	19
1.13 PM (Preventive maintenance)	20
1.14 Service Call	20
1.15 Calibration	21
Programming the Product Buttons	22
2. Product definition	22
2.1 Select Product	22
2.1 Raw Product	23
2.2 Fill level	23
2.3 Key Counters	24
2.4 Outlet variation	24
2.5 Mill quantity	25
2.6 Pressure	25
2.7 Pre-Inject	26
2.8 Temperatures	26
2.9 Preselect	27
2.10 Text	27
3. Adjust Card	28
3.1 Access A Access for managers (Accounting)	28
3.2 Access B Access for operating personnel.....	28
3.3 Access C Access for maintenance personnel	28
3.4 Config	29
3.5 Simulation	29
2. Clock	30
2.1 Date / Time	30
7. Show Counter	30
7.1 Machine Total	30
7.2 Prod. Total	30
7.3 Prod. Normal	30
7.4 Prod. Alt	30
7.5 Prod. Shift	30

7.6	Prod. Shift-Alt	30
7.7	Prod. Extern	30
4.	Fluid System	31
5.	View Counter	32
5.1	Machine	32
5.2	Prod. total	32
5.3	Prod. normal Screen 1/2	32
5.4	Prod. ALT Screen 3/4	32
5.5	Prod. SHIFT Screen 5/6	32
5.6	Prod. SHIFT-ALT Screen 7/8	32
5.7	Prod. extern Level and Option products	32
6.	Clear Counter	33
6.1	Machine Counter	33
6.2	Product Counter	33
7.	Data Backup	33
8.	Check Outputs	34
8.1	Relais 1	34
8.2	Relais 2	34
8.3	FET 1	34
8.4	FET 2	35
8.5	FET 3	35
8.6	FET 4 / Choco	35
8.7	Milk / Res 2	35
8.8	Brewing unit	36
9.	Check Inputs	37
9.1	A/D Channels	37
9.2	Digital Input	38
10.	Pin Code Install	38

Programming

All of the Sinfonia settings can be programmed with the Install Card. Navigation is via the five function keys as shown below. The card contains the chip for the machine and is inserted from below into the card reader; the card must remain there while performing the settings. The first time a new card is used the PIN code has to be entered and confirmed. The PIN code can be entered incorrectly a number of times without it being disabled. If, however, you forget the PIN code, the card is unusable and must be replaced. Once the entry has been confirmed, the card can be removed for 5 minutes without having to re-enter the code; the programming displays the exited menu setting. The described settings can also be made using the Service Tool. (The Service Tool is described in separate instructions).

Inserting the Install Card

The Sinfonia's chip card reader is located on the bottom of the front panel, to the left of the display.

Insert the Install card with the gold chip facing upwards and towards the machine.

If the card is inserted incorrectly, the display will indicate this by displaying "Read chipcard"



Programming Navigation

When using the Install card, five buttons are used to navigate through the programming tree

- A. The "Clean" button:
 - Accesses a parameter
 - Confirms the value of a parameter
 - Enters the value and advances to the next digit when entering the PIN code.
- B. Scrolls the cursor bar up through the parameter.
- C. Scrolls the cursor bar down through the parameter.
- D. Increases the value of a parameter.
- E. Decreases the value of a parameter.
 - Both D & E are used to activate and deactivate a function.

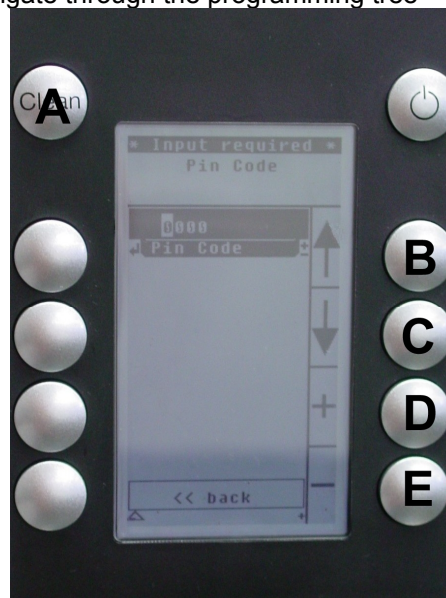

Entering the PIN Code

Once the Install card has been inserted into the card reader, the display will change and prompt you to insert the PIN code.

Use the programming buttons to enter the PIN code for the card inserted. For example, the factory PIN code is 0001. To enter this number, do the following.

1. Press the clean button three times
2. Press the “+” button once to change the fourth 0 to a 1.
3. Press the ↓ button to move the cursor to the Exit Save line.
4. Press the Clean button to enter the PIN code.

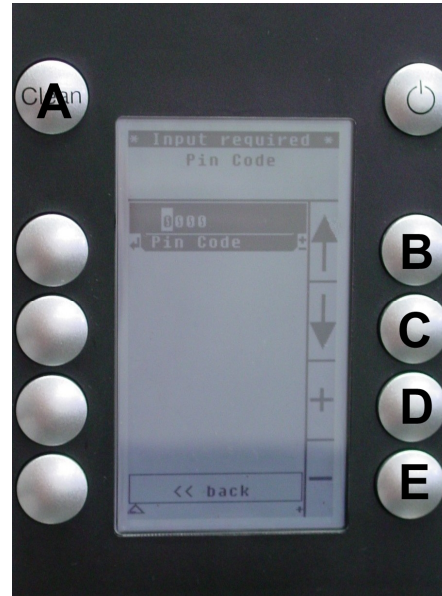

Once the correct PIN code has been entered, the display will change to display the parameters accessible with the Install card.

1 Set-up	Configures the machine's basic operational settings.
2 Prod. Def.	Programs the product buttons, i.e. Dbl Latte.
3 Adjust Card	Allows access to the parameters available when the Adjust card is inserted into the card reader.
4 Fluid-system	Access the “emptying” and “pressure adjustment” parameters.
5 View Counter	Accesses the “history” of the machine, cycle counts, component operational times, etc.
6 CLR Counter	Clears the values of certain values found in the view counter parameter.
7 Data-Backup	Saves the machine's settings and product programming.
8 CheckOutputs	Allows you to test the operation of the machines components.
9 Checkinputs	Allows you to test the input signals from the machine switches and readers.
10 Pin Code	Allows you change the PIN code on the Install card.

Install Menu 1 – 2

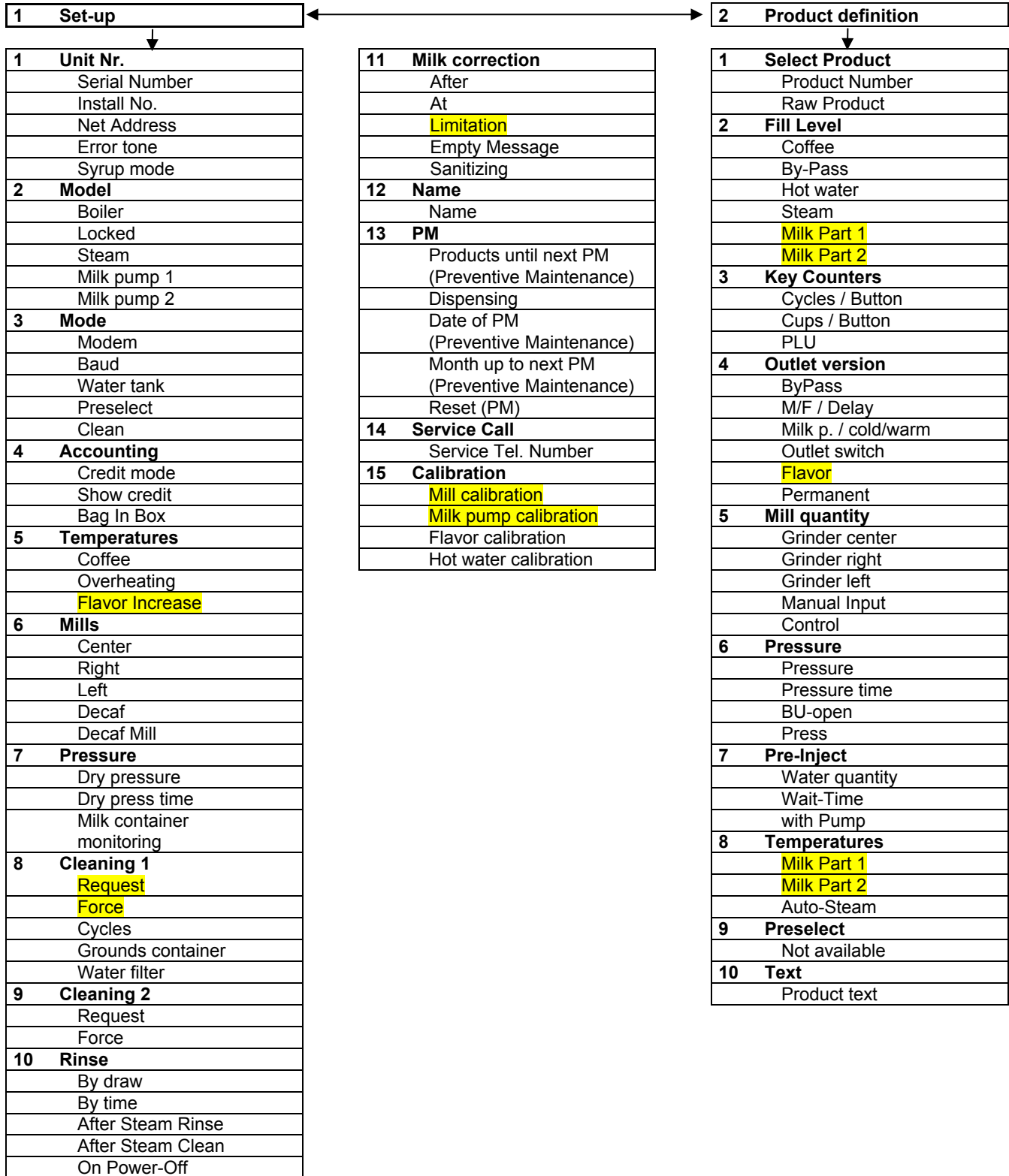

Install Menu 3 – 7

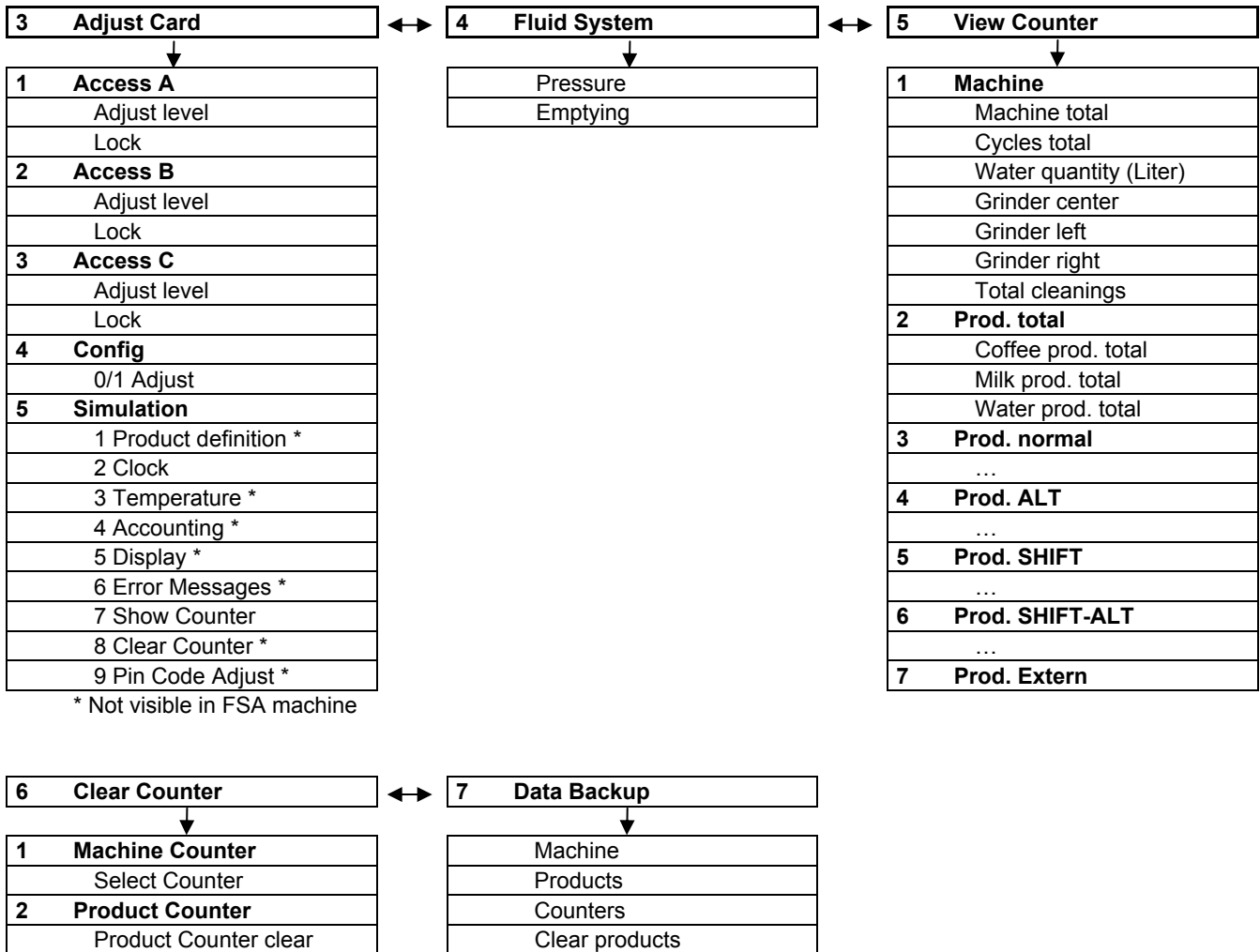

Install Menu 8 – 10

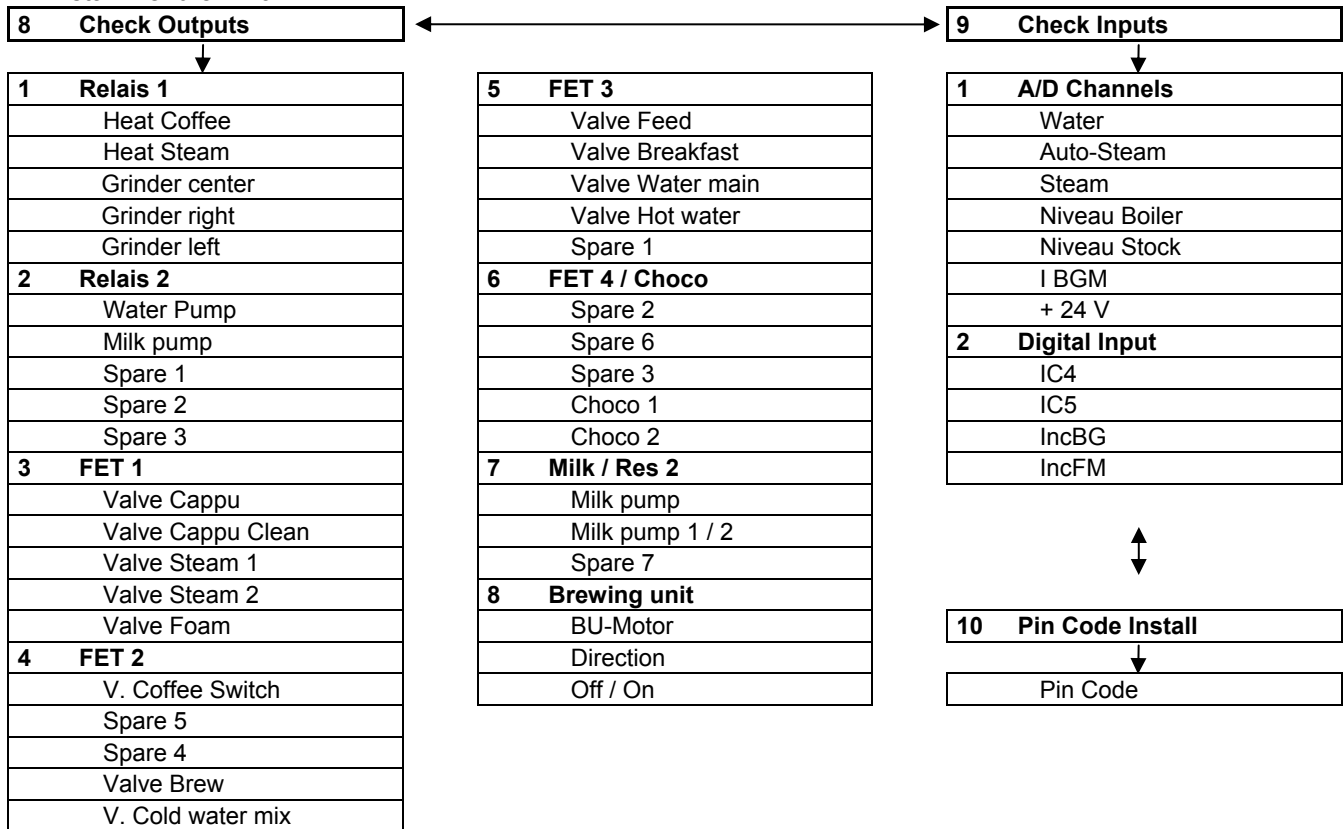

Symbols appearing in the display

In standby mode (ESM)

Internal Flash

Version I	:	25.03r37
Version X	:	25.03r37

External Flash

At start-up

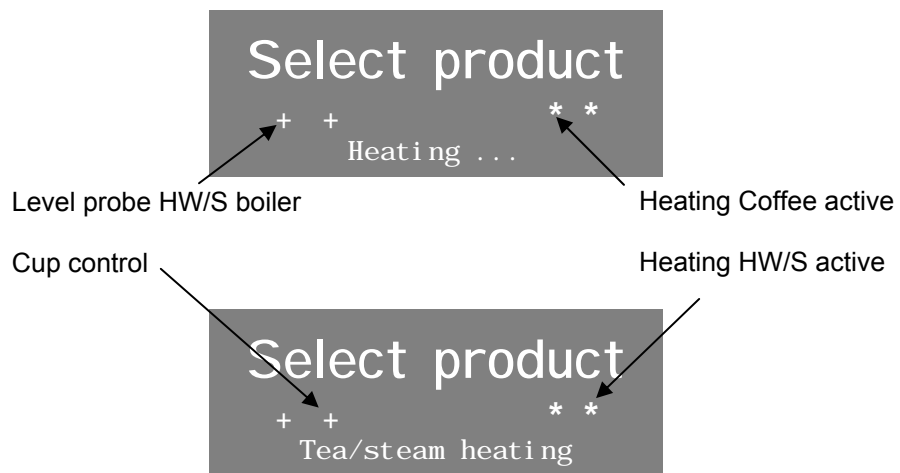

When programming

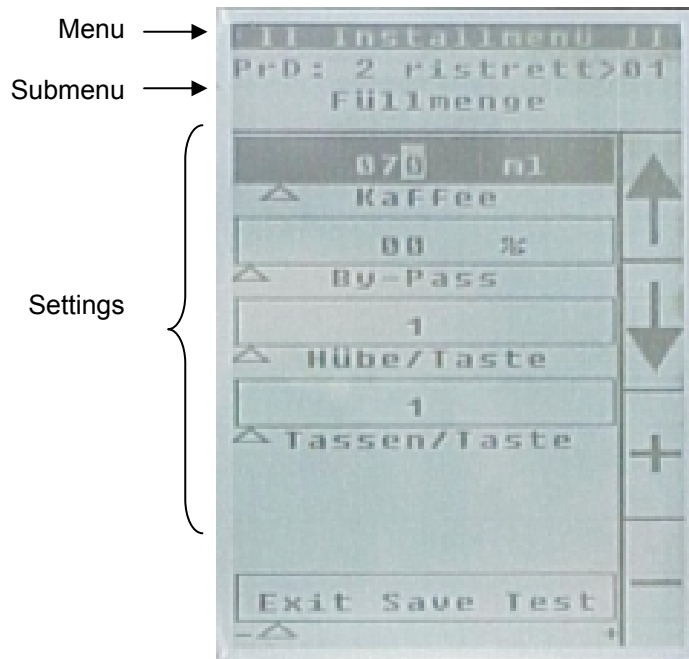



1. Set-up
1.1 Unit Nr.

Serial Number

[1,2,3,4,5,6,7,8,9,0] Indicates the serial number set by the factory.
(First digit = 0)

	Year	Type	Number
3	9	4	00235
	1 = 1980		
	2 = 1990		
3 = 2000	9 = 2009	4 = Sinfonia	

Install No.

[1,2,3,4,5,6,7,8,9,0] Indicates the serial number set by the factory.
Identification for Adjust Card (First digit = 0)

Net Address

[0 – 99]  Used only when networked with other
Coffee machines and in accounting mode
(Setting without network = 00)

Error tone

[no / yes] Yes: Buzzer key:

-  Alternating beep 0.2 sec. ON / 1 sec. OFF
- External RAM
 - Drawer full
 - Grounds door or control panel open
 - Coffee outlet missing
 - Heater error (e.g. NTC short error)
 - Main water error
- Alternating beep 0.2 sec. ON / 5 sec. OFF
- Other errors (e.g. brewing unit motor, no beans, no milk, communication, empty drawer, battery low)

Syrup mode

[no syrup] -
[Parallel] -
[Binary] -

1.2 Model

Boiler

[1 / 2]

Number of boilers present

Locked

[no / yes]

No: For 400V 2P NE connection
 Yes: For 230V 1P NE connection
 Yes: For 208V 1P E UL connection

Steam

[no / yes]

No: HW/S boiler is filled completely
 Yes: Steam wand or milk system present

Milk pump 1

[no / yes]

No: No milk pump
 Yes: With standard milk pump

Milk pump 2

[no / yes]

No: No additional pump
 Yes: With additional pump

1.3 Mode

Modem

[no / yes]

No: No modem connected

Baud

from Software S4S Version 15.8

[96 / 192]

Transmission speed of the modem



Can be set only in the Service Tool up to software standard version 1.9

Water tank

[no / yes]

Yes: Water tank operation monitoring

Preselect

[no / yes]

- Products processed in the sequence in which they are entered
- Deletion with Clean button

 Dispensing according to grounds container or forced cleaning
 Preselection 0 = grounds disposal
 = 99 product/button

 With accounting system only the current product will be cleared

Clean

[Lift / Time]

 Following setting 1.8

1.4 Accounting

Credit mode

[no / yes]

No: No accounting system

Show credit

[no / yes]

No: Only with billing system
 Yes: Also in the Sinfonia display

Bag in Box

[no / yes]

No: Using MUT with gallon jugs
 Yes: Using Bagmilk container

1.5 Temperatures

Coffee

T...°C [10 – 100]
 (Celsius)

Sets the brewing water temperature in the coffee boiler

Overheating

T 2°C [0 – 3]
 (Celsius)

0 for OFF
 1 for max. 2°C
 2 for max. 4°C
 3 for max. 6°C

 Every 10 min. the temperature in the coffee boiler is increased by 1°C

Flavor increase

T...°C [00 – 10]

When selected, the milk temperature is increased to compensate for the cold syrup

1.6 Mills

Center

[no / yes]

Select yes if the Sinfonia is equipped with a center grinder

Right

[no / yes]

Select yes if the Sinfonia is equipped with a right grinder

Left

[no / yes]

Select yes if the Sinfonia is equipped with a left grinder

Decaf

[Off / On]

Assignment of the grinder to additional button

Decaf Mill

[Left / Right]

Assignment of the grinder to additional button

1.7 Pressure

Dry pressure

PWM % [0 – 80]
(Pulse width modulation)

See Settings 2.5 for PWM definition

Dry press time

[0 – 50]
(Tenth of a second)

Dry pressing time of the coffee grounds cake after brewing

Check milk container on cleaning

[no / yes]

The monitoring of the milk sensor is either de-activated or activated during cleaning

1.8 Cleaning 1

Request by time

hhmm [0000 – 2359]
(Hours / Minutes)

Cleaning request by time
If at least one product has been dispensed
0 for disabled

Force by time

hhmm [0000 – 2359]
(Hours / Minutes)

Forced cleaning by time
If at least one product has been dispensed
0 for disabled

or

Request by lifts

lifts [0 – 1000]  0 for disabled

Force by lifts

lifts [0 – 999]  Number of strokes after request
0 for disabled

-  Cancel cleaning:
1. Press and hold the Clean Button to start the Cleaning Cycle.
 2. Power off the unit.
 3. Insert Install Card
 4. Power on unit.
 5. Enter Pin Code and press the Clean button twice.
 6. Unit will enter energy save mode.
 7. Remove Install Card
 8. Power On Sinfonia

Cycles

[4 – 9]  Cycles needed to dissolve the cleaning tablet

Grounds container

piece [0 – 150]  10 pcs. before the programmed number the message “Empty drawer” appears

 When the number is reached, the message “Drawer full” is displayed and it is not possible to dispense coffee products

Water filter

Lit. [0 – 10000] 0 for OFF
(Liter)

 Direct count corresponding to the flow meter for consumption from coffee boiler
Indirect count for consumption from HW/S boiler

1.9 Cleaning 2

Request by lifts

lifts [0 – 1000]  0 for disabled

Force by lifts

lifts [0 – 999]  Number of cycles after request
0 for disabled

1.10 Rinse

By draw

min [0 – 99]
(Minutes)

For coffee and milk products

By time

hrs [0 – 5]
(Hours)

Forced rinsing with continuous dispensing
(If the rinse by draw has not be reached)

After Steam Rinse

[5 – 600]
(Tenth of a second)

Time adjustment and optical check
when using long milk lines (MUT)

Attention with CF1/2

After Steam Clean

[50 – 600]
(Tenth of a second)

Time adjustment and optical check
when using long milk lines (MUT)

Rinse

[Never]

If at least one coffee or milk product
Has been dispensed

[When OFF]
[When ON]

Forced rinsing when switched OFF
Forced rinsing when switched ON

1.11 Milk correction

After

min [0 – 6]
(Seconds)

 The milk quantity correction begins after the programmed time

At

T °C [0 – 6]

 The milk temperature is increased / corrected by the programmed value

Limitation

T °C [0 – 18]

 The max. milk temperature correction is limited to the programmed value

Empty Message

10ml [0 – 50]

 The number of milk/coffee products that can still be dispensed after the empty message from the level sensor

Runtime sanitizing

sec [0 – 120]
(Seconds)

 Enter the time in seconds for runtime of the sanitizing process

1.12 Name

Name

[A, B, C, ...]

A custom text can be displayed when the Sinfonia is in standby mode

Start text entry:
- Press ↓ arrow button

 Text length maximum 14 characters
With Service Tool maximum 18 characters
(Changes after an upload are displayed after switching on the machine)

 Space before and after Euro symbol (€)

Move cursor with:

↑ - up
↓ - down
+ - right
- - left

Finish text entry:
- Move cursor down to "Character selection"

1.13 PM (Preventive maintenance)

Products until next PM

[...]

Show the number of products until the next maintenance

Dispensing

[0 - 100]

Date of PM

[Date]

Date of the last maintenance

Month up to next PM

[0 - 12]

Perform PM message will be displayed when selected maintenance time is reached from date of reset. Select 0 and reset to yes to disable.

Reset

N Y [no / yes]

Resets the maintenance counter above.

1.14 Service Call

Service Tel. number

[...]

The service call telephone number can be entered here

1.15 Calibration**Mill calibration****Grinder center**

150	0.1g	[50 - 300]
-----	------	------------

Grinder right

150	0.1g	[50 - 300]
-----	------	------------

Grinder left

150	0.1g	[50 - 300]
-----	------	------------

Milk pump calibration**Milk pump 1**

130	ml	[10 - 500]
-----	----	------------

Milk pump 2

130	ml	[10 - 500]
-----	----	------------

Flavor calibration

		[...]
--	--	-------

NOT AVAILABLE

Hot water calibration

005	ml	[0 - 999]
-----	----	-----------

Default for machines without hot water outlets is 005ml

Programming the Product Buttons

2. Product definition

2.1 Select Product

Product Number

[0 – 42]



Product buttons FSA

Button	Screen 1	Screen 2	Screen 3	Screen 4	Screen 5	Screen 6	Screen 7	Screen 8
A	1	5	9	13	17	21	25	29
B	2	6	10	14	18	22	26	30
C	3	7	11	15	19	23	27	31
D	4	8	12	16	20	24	28	32
Button	Drink-Modifier							
I	33							
K	34 (n/a)							
L	35	Level						
M	36							
N	37							
O	38							
P	39	Option						
Q	40							
R	41							
S	42							
EXTERN	43-46							



To the following settings applies

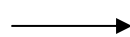

Display corresponds to product selection

2.1 Raw Product

1	[no Product] [Ristretto] [Espresso] [Coffee] [Milk coffee] [Cappuccino] [Macchiato] [Cold milk] [Hot milk] [Frothed milk] [Hot water] [Cold water] [Steam] [Auto-Steam] [Level] [Option] [Prime milk] [External]
---	---

Selecting a new “raw product” will change the drink values to the default product values found on pages 87-88.

2.2 Fill level

Coffee / Water / Steam

000 ml (Milliliter)	[0 – 800]	Coffee product
000 0.1s (Tenth of a second)	[0 – 500]	Water product
0000 0.1s (Tenth of a second)	[0 – 1200]	Steam product

By-Pass

00 % (Percent)	[0 – 80]	 Hot water portion of the coffee fill quantity
-------------------	----------	---

Milk Part 1

000	[0 – 600]	 Products with milk or frothed milk
-----	-----------	--

Milk Part 2

000	[0 – 255]	 Products with two milk parts (e.g. frothed milk for Macchiato)
-----	-----------	---

2.3 Key Counters

Cycles / Button

[0 – 6]

Number of strokes per product

Cups / Button

[1 – 6]

Cup counter per product

PLU

(Product look-up)

[0 – 900]

Product number for accounting system
(The basic setting is consecutive button numbering)

2.4 Outlet variation

ByPass

[Start / End]

Add hot water portion at beginning or end of the brewing process

Milk, Coffee
Milk + Coffee
Coffee, Milk

Milk before coffee delays brewing
Milk with coffee
Coffee before milk delays the milk run time

 sec

(Seconds)

[00 – 50]

Delay time
0 for milk with coffee

Change the outlet variant with the minus button if delay time is 0 seconds

Milk part cold/warm

[- – +]

Temperature of milk part

Syrup

 ml

[1 / 2]

The amount of milk to be remove when the syrup button is selected.

Outlet switch

Option

[no / yes]

Yes: e.g. pot outlet placed on “steam pipe”

Only for coffee products

Permanent

[no / yes]

Yes: Output as long as button is pressed or programmed fill quantity reached

No: Press button once for prog. quantity

Only for milk and water products

2.5 Mill quantity

Grinder center

[0 – 300]

 Brewing chamber capacity max. 15 grams

 If multiple grinders are programmed, the control system actuates first the middle grinder, then the right grinder, then the left grinder (No time reduction!)

Grinder right

[0 – 300]

Grinder left

[0 – 300]

Manual Input

[no / yes]

Yes: Setting performed automatically if all grinders are set with 0 tenth of a second

Control

[no / yes]

Yes: For monitoring bean quantity level
No: Less than 6 grams of mill quantity

 Check done with the incremental encoder of the brewing unit motor

2.6 Pressure

Pressure

[0 – 80]

 With too little PWM the BU motor lacks the required force to overcome the resistance of the piston gasket (Not enough voltage)

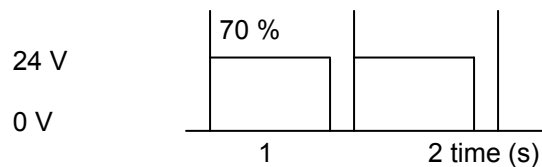
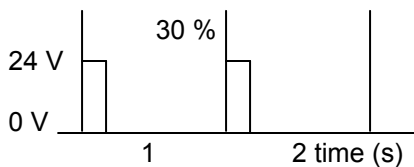

Pressure time

[0 – 50]
(Tenth of a second)

Pressing ground coffee

BU-open

[0 – 20]
(Increments)

Opening the brewing unit for brewing process

Warning: Pay attention to the piston position!

Press

[1 / 2]

1 for one stroke with “dry” coffee cake
2 for double stroke with “wet” coffee cake

2.7 Pre-Inject

Water quantity

[0 – 99]
(Milliliter)

Water amount of the preinfusion is in addition to the fill amount

Wait-Time

[0 – 600]
(Tenth of a second)

Time after preinfusion
(Caution with long waiting time in self-service!)

with Pump

[no / yes]

Yes: Default setting!
No: Prebrewing only with building pressure

2.8 Temperatures

Milk Part 1

[50 – 90]

50 for cold, without steam
51 - 90 for hot, with steam

Milk Part 2

[0 – 100]

0 for cold, without steam
1 - 100 for hot, with steam

Auto-Steam *Option*

[10 – 100]
(Celsius)

2.9 Preselect**Preselect (NOT AVAILABLE)** [no / yes]

2.10 Text**Product text** [A, B, C, ...]

The raw product can be described with custom text



See Settings 2.8 for character selection



Own product texts, as described for software standard version 1.9, are no longer shown on the display



Own products can be displayed only with the Service Tool (Graphic Designer)



It is nevertheless recommended to adapt your own product texts in the product definitions, since they continue to be used in the counter status.

3. Adjust Card

3.1 Access A

Access for managers (Accounting)

3.2 Access B

Access for operating personnel

3.3 Access C

Access for maintenance personnel

Adjust level

[0 – 90]

Customer Menu 1 – 9

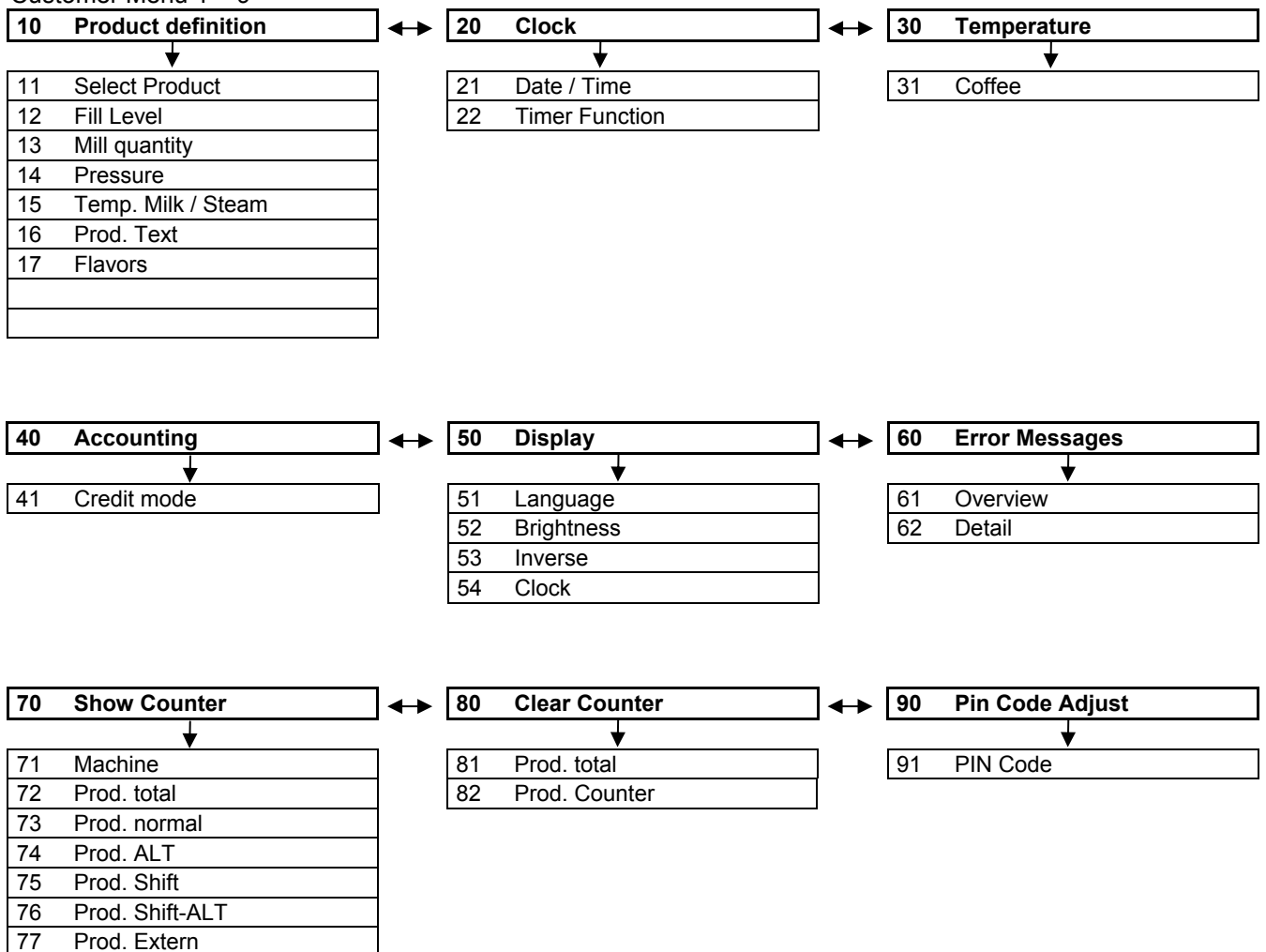

Lock

[no / yes]



A minus number means disabled

Possible display:

10 - 11 12 - 13 - 14
- 15 - 16 - 17 20 etc.

3.4 Config**0 / 1 Adjust** 0/1

[no / yes]

No: On/Off button not disabled

Yes: Switch On/Off only with Adjust - /
Install Card

3.5 Simulation**1 Product definition**

See customer menu settings

2 Clock**3 Temperature****4 Accounting****5 Display****6 Error Messages****7 Show Counters****8 Clear Counters****9 Pin Code Adjust**

The Adjust Card simulated only with Access A

To access the Install menu again, the Install
Card must be taken out of the card reader and
then reinserted

Settings with the Adjust Card

Settings in the Customer Menu for McDonald's are limited to setting Date / Time and Show Counters.

2. Clock

2.1 **Date / Time**

Year, Month, Day, Hour, Minute

7. Show Counter

7.1 **Machine Total**

Machine total
Cycles total
Water quantity total
Grinder Center total hrs.
Grinder Left total hrs.
Grinder Right total hrs.
Total Cleanings

7.2 **Prod. Total**

Total number of coffee products
Total number of milk products
Total number of water products

7.3 **Prod. Normal**

Product Total dispensed from the Small / Medium Menu (Screen 1 & 2)

7.4 **Prod. Alt**

Product Total dispensed from the Large / Sample Menu (Screen 3 & 4)

7.5 **Prod. Shift**

Product Total dispensed from the Special products Small / Medium Menu (Screen 5 & 6)

7.6 **Prod. Shift-Alt**

Product Total dispensed from the Special products Large / Sample Menu (Screen 7 & 8)

7.7 **Prod. Extern**

Total number of products dispensed from the External Menu
(Espresso button and Modifier buttons)

4. Fluid System

Pressure

[no / yes]

Set pump pressure to 8 bar

 Main water valve and pump become active
Brewing valve Y1 opens every 5 sec. for
0.1 sec. to release pressure

Emptying

[no / yes]

Yes: emptying is started
No: stop emptying

 Process takes about 2.5 min. and must be
ended with the minus button

 All valves are active and the pump runs after
10 sec. for 2 sec.

Additional display

65535
(Increments Flowmeter)

Flow meter check

0450
(Resistor level probe)

Boiler check (Values for empty or full)

 ~ 450 = no calcification
~ 600 = calcification

5. View Counter

5.1 Machine

Machine total

[0 – ~]

Without water or steam products

Cycles total

[0 – ~]

Example with date on which the counter was reset.
Don't forget to reset after brew unit replacement.

Water quantity

[0 – ~]
(Liter)

For coffee and water products

Grinder center

Grinder left

Grinder right

[time]
(Hours / Minutes / Seconds)

Total grinder run time.
Don't forget to reset after burr replacement.

Total cleanings

[0 – ~]

5.2 Prod. total

Coffee prod. total

Milk prod. total

Water prod. total

[0 – ~]

- 5.3 Prod. normal Screen 1/2
- 5.4 Prod. ALT Screen 3/4
- 5.5 Prod. SHIFT Screen 5/6
- 5.6 Prod. SHIFT-ALT Screen 7/8
- 5.7 Prod. extern Level and Option products

[0 – ~]

6. Clear Counter

6.1 Machine Counter

Select Counter

[01 – 08]

Each counter must be individually deleted

6.2 Product Counter

Product Counter really clear?

[- – +]

All product counters will be deleted

Exception for counters:
- coffee, milk, and water product totals

These have to be deleted as under Setting 6.1

7. Data Backup

Manual and individual data restore of machine and product configurations and machine counters from Flash memory into RAM (e.g. for machines with the same products)

Automatic data backup:
- when removing the chip card
- when switching off properly
- after 8 hours of operating time (Not standby)

Machine

[no / yes]

Products

[no / yes]

Counters

[no / yes]

Clear products

[no / yes]

Yes: Clears ALL products

8. Check Outputs

[no / yes]

Yes: Output active

No: Output deactivated

8.1 Relais 1

Heat Coffee

Heat Steam

Grinder center

Grinder right

Grinder left

8.2 Relais 2

Water Pump

Milk pump

[1 / 2]



Relay check

Spare 1

Spare 2

Spare 3

8.3 FET 1

Valve Cappu Steam (Y20)

Valve Cappu Clean (Y30)

Valve Steam 1 (Y6)

Valve Steam 2 (Y6')

Valve Foam / Air Valve (Y31)

8.4 FET 2**V. Coffee Switch (Y2)****Spare 5****Spare 4****Valve Brew (Y1)****V. Cold water mix (Y4')**

8.5 FET 3**Valve Feed (Y5)****Valve Breakfast (By-Pass) (Y3)****Valve Water Main (Y33)****Valve Hot water (Y4)****Spare 1**

8.6 FET 4 / Choco**Spare 2****Spare 6****Spare 3****Choco 1****Choco 2**

8.7 Milk / Res 2**Milk pump** PWM % [0 – 100]100 for OFF
001 for full performance**Milk pump 1 / 2** [1 / 2] Pump selection**Spare 7** PWM % [0 – 100]

8.8 Brewing unit

BU-Motor

PWM % [0 – 100]

Desired speed by preselecting pulse width modulation. You must select between 30% and 70% to make the BU move up or down
Frequency of brew unit motor is 12kHz.

Direction

[Up / Down]

Off / On

[Off / On]

Additional display

0000
(Current BU-Motor)

Motor check

Value 138 corresponds to 1 ampere

65535
(Increments BU-Motor)

Motor check

The increment difference between brewing group above and below corresponds to the stroke length = difference IncBG x 0.4 mm

9. Check Inputs

9.1 A/D Channels

Water 0000	[0000 – 9999]	}	{	1024 = ∞ interrupt / 942 ≈ 25°C /
A-Steam 0000	[0000 – 9999]			720 ≈ 70°C / 645 ≈ 80°C / 605 ≈ 85°C /
Steam 0000	[0000 – 9999]			570 ≈ 90°C / 530 ≈ 95°C / 490 ≈ 100°C
Niveau Boiler 0000	[0000 – 9999]			780 ≈ empty / 400-600 ≈ full
Niveau Stock 0000	[0000 – 9999]			Spare
I BGM 0000	[0000 – 9999]			Check at 8.8
+ 24 V 0000	[0000 – 9999]			Jumper on 200V / Frequency = 60Hz

VAC~	VDC-	AD Value
170	22.75	454
180	24.25	517
190	25.7	580
200	27.2	643
210	28.65	705
220	30.13	769
230	31.6	831
240	33.05	985
250	34.52	957
260	36	1018

9.2 Digital Input

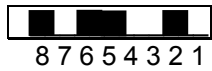

[/]

:Off
 :On

IC 4 Bit	8	Cup control
	7	Panel control
	6	Door control
	5	Outlet control
	4	Accounting
	3	Spare 2
	2	Pressure switch control
	1	Spare 1

IC 5 Bit	8	Spare 5
	7	Tank control
	6	Milk level
	5	Spare 4
	4	Spare opto 2
	3	Spare opto 1
	2	Spare 7
1	Spare 6	

IncBG Check at 8.8

IncFM Check at 4.0

10. Pin Code Install

Pin Code

[0000 – 9999]

Enter new PIN code

Franke Sinfonia FSA

Technical Training Manual

Components / Hydraulic System – Chapter 7

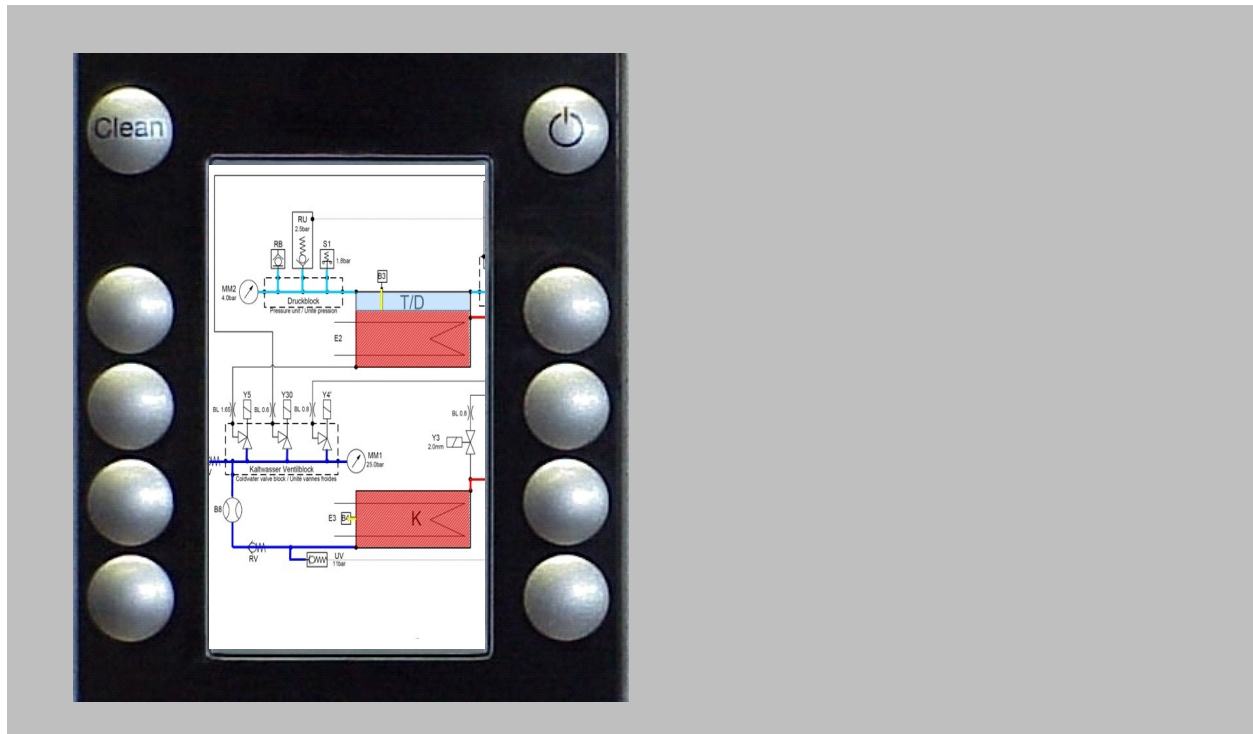

Franke Coffee Systems
800 Aviation Parkway
Smyrna, TN 37167
(615) 462-4000

Change log

Date	Changes	Author	Change No.	ID
2009-07-20	New Manual Concept	MPH		
2010-03-01	Div. changes to contents	MPH		A

Publisher:

Franke Kaffeemaschinen AG
 P.O. Box 235
 CH-4663 Aarburg
 Switzerland

www.franke-cs.com

Table of Contents

Change log	2
Table of Contents	3
Safety Notes	4
Safety	5
Steam System	5
Hydraulic System	5
Machine Overview	6
Internal Components - Right Side	7
Internal Components - Left Side	8
Internal Components - Rear	9
Internal Components - Top	10
Hydraulic System	11
Mains Valve Y33 (Item 1)	12
Pump/Motor Assembly M2 (Item 2)	12
Check Valve RV (Item 3)	12
Cold Water Valve Block (Item 4)	13
Pressure Gauge MM1 (Item 5)	13
Flowmeter B8 (Item 6)	13
“T” Fitting (Item 7)	13
Over-pressure Relief Valve UV (Item 8)	14
By-pass Valve Y3 (Item 9)	14
Coffee Valve Y1	14
Brew Unit	15
Boilers	16
Coffee Boiler E3 (Item 1)	16
Steam Boiler E2 (Item 2)	16
Auto-fill Probe	17
Pressure Block	17
Vacuum Breaker RB (Item 1)	18
Pressure Relieve Valve RU (Item 2)	18
Pressure Switch S1 (Item 3)	18
Pressure Gauge MM2 (Item 4)	18
Hot Valve Block	19
Y20 Cappu Steam Valve (Item 1)	19
Y6 Steam Valve 1 (Item 2)	19
Y6' Steam Valve 2 (Item 3)	19
Y4 Tea Valve (Item 4)	19
Hydraulic Schematics	20
Legend: Waterflow Diagram	21
Sinfonia FSA One-Step MUT Milk System	22
CF components	23
Check Valve Body	23
Outlet Nozzles	23
CF Foaming Unit	24
Milk System CF MUT 4 FSA	25

Safety Notes

The installation, setting, repair and maintenance work described in these instructions must be performed only by service technicians trained by Franke Coffee Systems Americas Inc. and when using original Franke parts!

Observe the following dangers and warnings when servicing coffee machines with live voltage.



DANGER!
Indicates potentially life threatening Danger!
Electrocution caused by coming in contact with live voltage.
Safeguard parts with live voltage against contact.



WARNING!
Indicates risk of injury!
You may suffer injuries due to moving parts crushing fingers and hands.
Secure moving parts against unintentional movement.



CAUTION!
Indicates risk of minor injury!
Avoid burns caused by hot water, steam, hot milk, or milk foam



NOTE!
Indicates possibility of damage to the machine.

Safety

**DANGER**

Steam System

Before performing maintenance on any steam related component, ensure the following:

- Disconnect the machine from the water supply.
- Always disconnect the machine from its power source.
- Empty the machine before performing any work on the boiler system.

**DANGER**

Hydraulic System

Before performing maintenance on any hydraulic related component, ensure the following:

- Disconnect the machine from the water supply.
- Always disconnect the machine from its power source.
- Empty the machine before performing any work on the boiler system.

Machine Overview

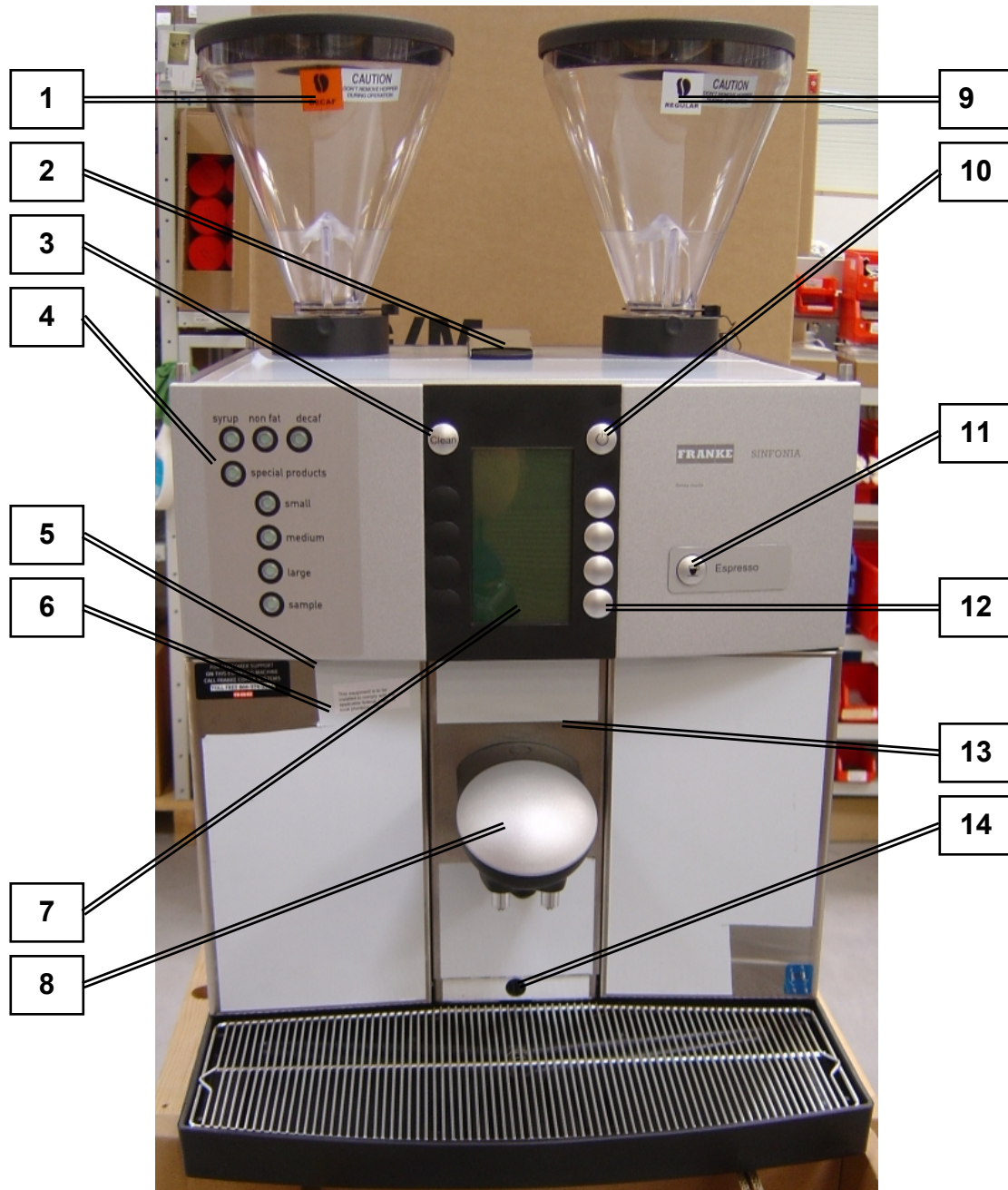

1. Left Hopper
2. Cleaning Tablet Chute
3. Clean Button
4. Preselection Buttons
5. Chip Card Reader
6. Grounds Container Door
7. Display

8. Coffee Outlet
9. Right Hopper
10. Power Button
11. Espresso Product Button
12. Product Buttons
13. Adjustable Outlet
14. Cup Sensor

Internal Components - Right Side

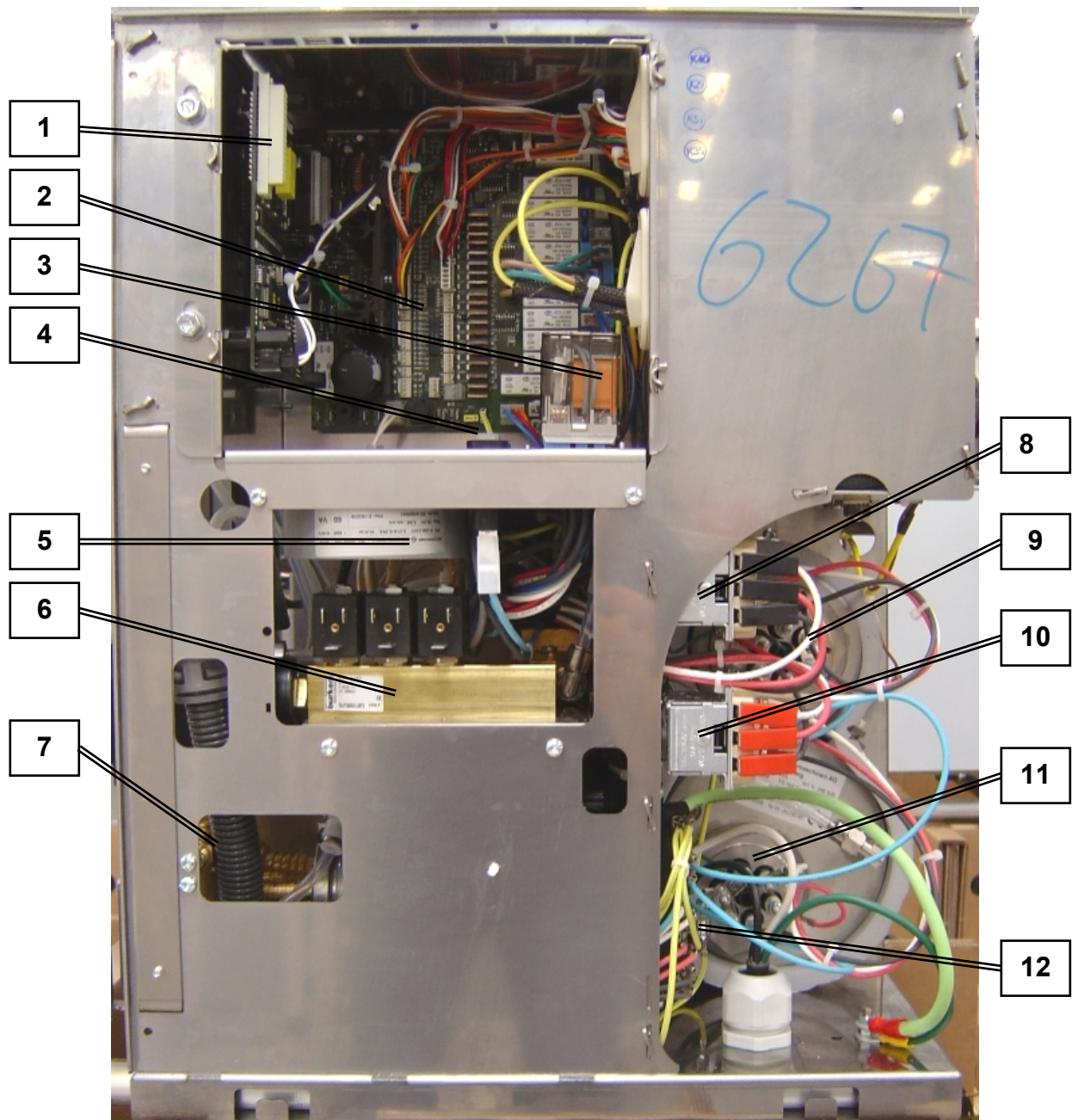

- | | |
|-------------------------|-----------------------------------|
| 1. CPU Print Board | 7. Pump Pressure Adjustment Screw |
| 2. Power Print Board | 8. Coffee Boiler Klixon |
| 3. Heater Relays | 9. Coffee Boiler Heating Element |
| 4. Fuses | 10. Steam Boiler Klixon |
| 5. Stepdown Transformer | 11. Steam Boiler Heating Element |
| 6. Cold Water Block | 12. Terminal Block |

Internal Components - Left Side

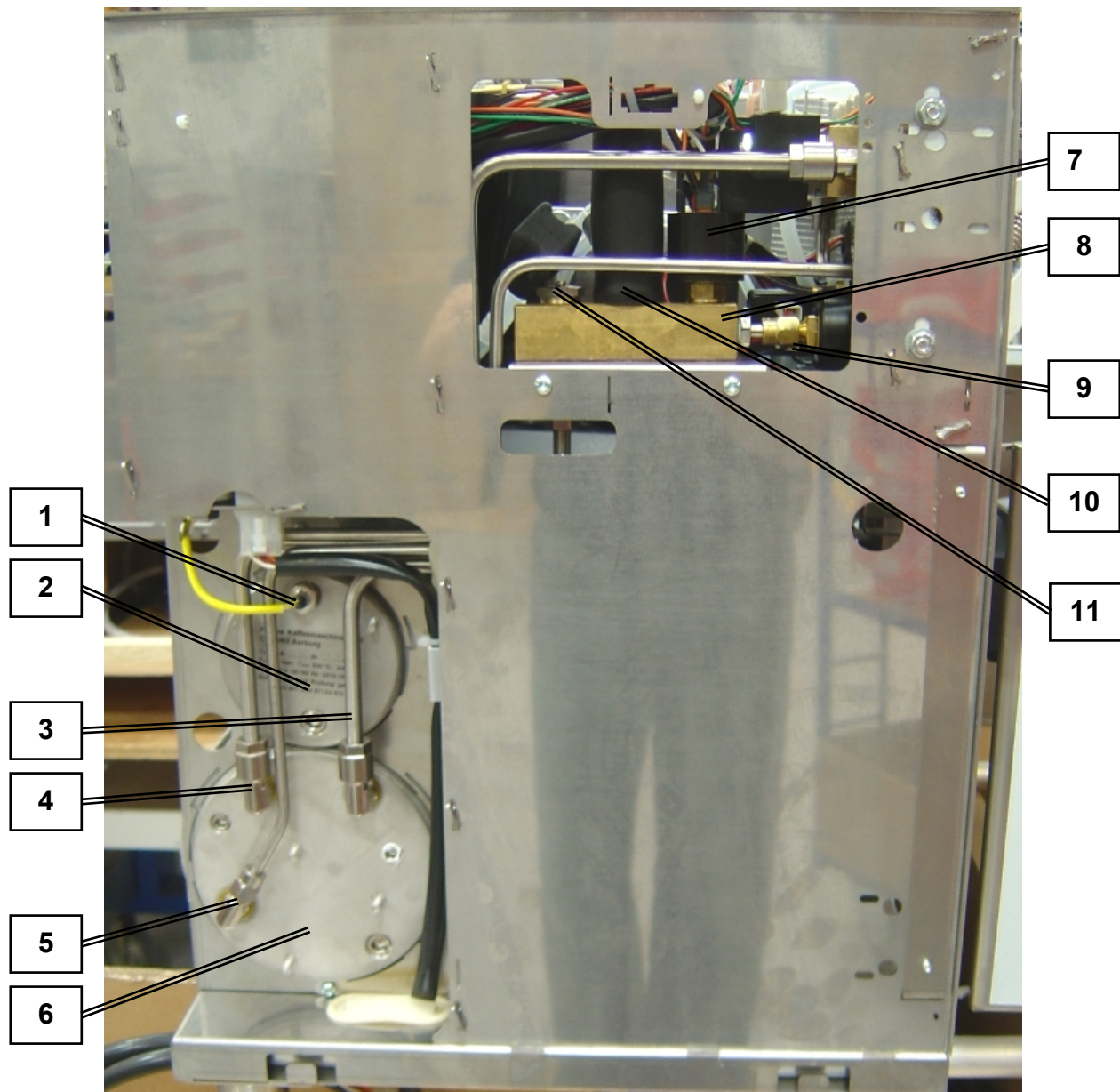

- 1. Coffee Boiler Thermostat
- 2. Coffee Boiler
- 3. Steam tube to pressure block
- 4. Tube to hot valve block
- 5. Hot water to the hot valve block

- 6. Steam Boiler
- 7. Pressure Switch
- 8. Pressure Block
- 9. Pressure Gauge
- 10. Pressure Relief Valve
- 11. Vacuum breaker

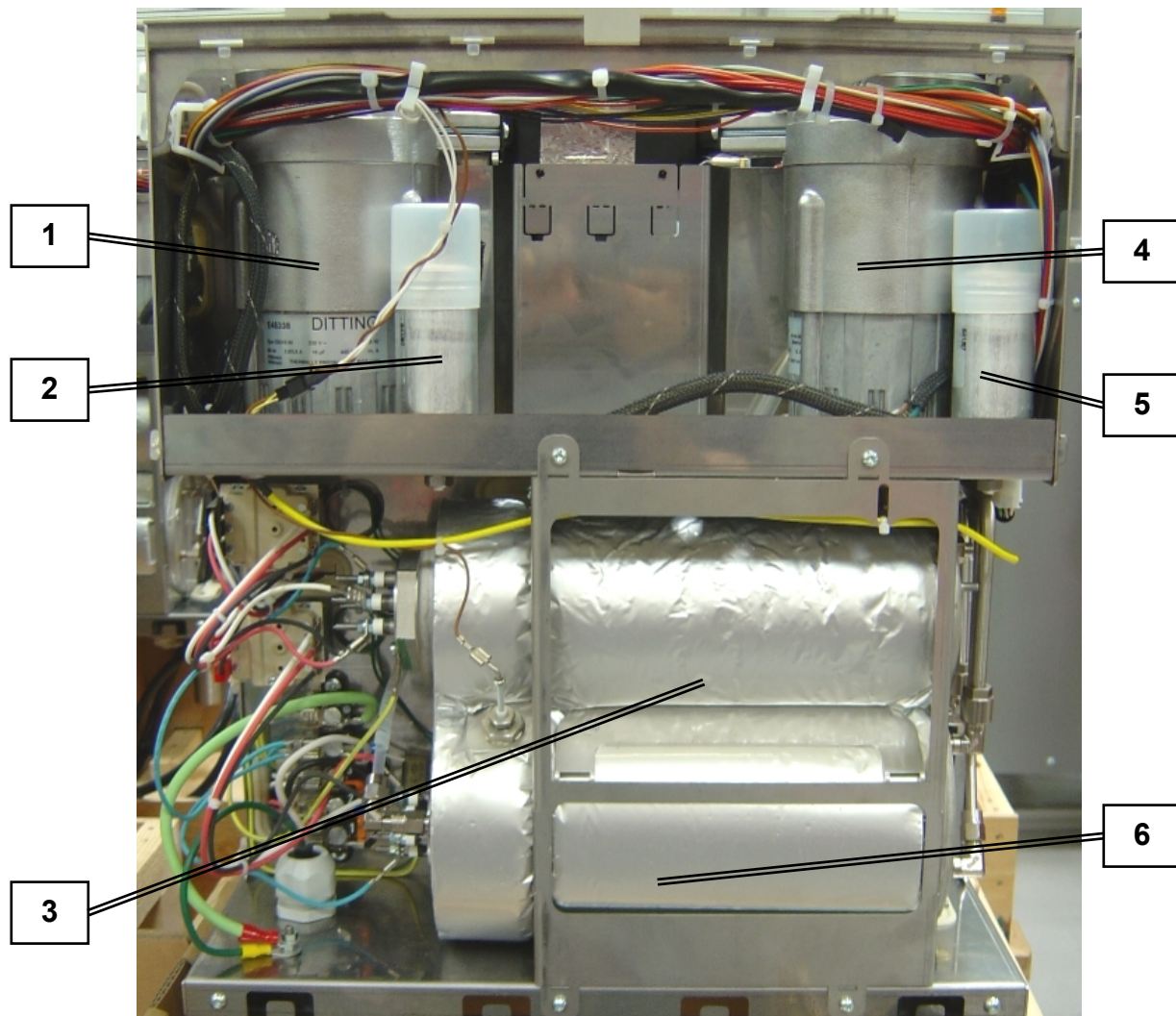
Internal Components - Rear

1. Right Grinder Motor
2. Right Grinder Capacitor
3. Coffee Boiler

4. Left Grinder Motor
5. Left Grinder Capacitor
6. Steam Boiler

Internal Components - Top

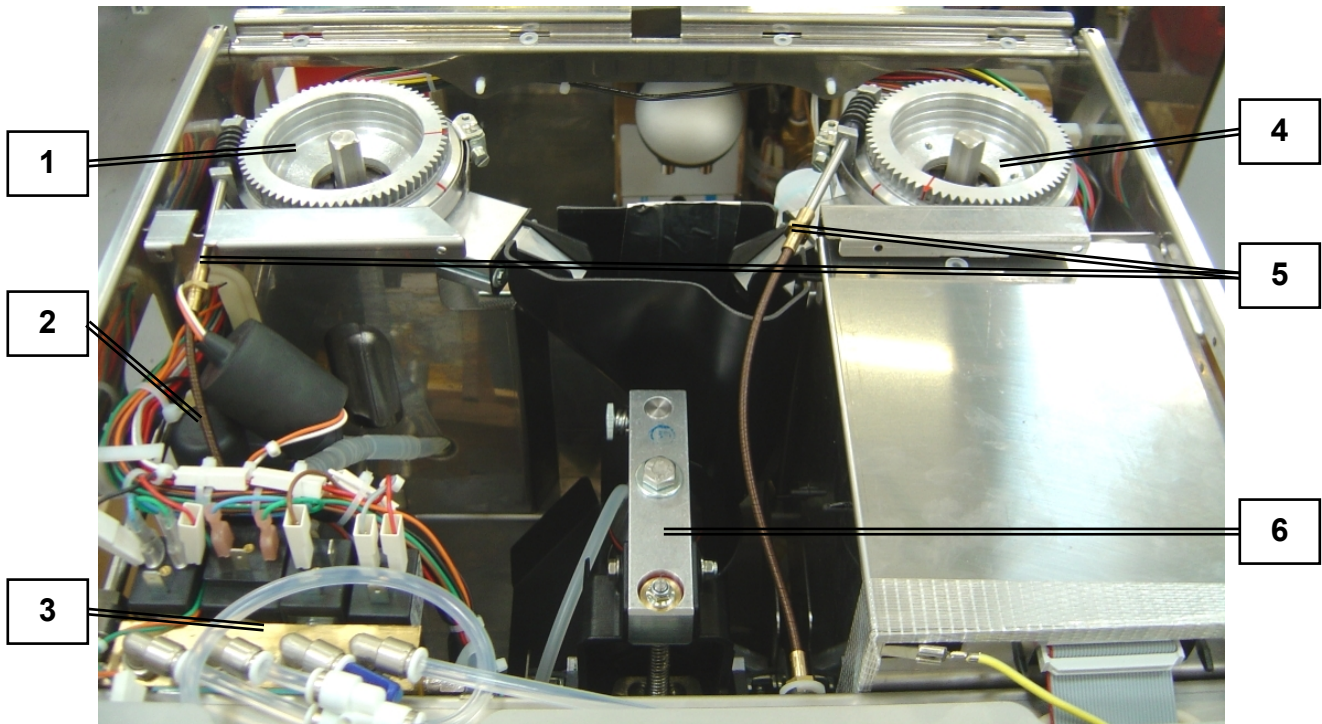

- 1. Left Grinder
- 2. Pressure Relief Valve
- 3. Hot Valve Block

- 4. Right Grinder
- 5. Grind Adjustment Cables
- 6. Brewing Unit

Hydraulic System

Like the Evolution, the Sinfonia uses valve blocks equipped with several valves instead of each valve being equipped with its own body, installed throughout the machine.



The following section follows the order of flow of through the Sinfonia's hydraulic circuit starting with the cold water block, followed by the boilers, the pressure block and finally, the hot valve block.

Mains Valve Y33 (Item 1)

The mains valve is where incoming water enters the Sinfonia.

- The mains valve acts as
 - 1 - a back flow preventer by opening whenever a drink selection is made and then closing again, preventing any water in the machine from traveling back into the inlet water line
 - 2 - as a safety valve that prevents water from leaking through the machine when it not in use.
- It is located behind the door directly behind the tea and steam wands.
- It has a yellow 24vdc coil installed on a plastic body. Use caution when installing the water inlet hose so as not to cross-thread the fitting, damaging the mains valve.

From the outlet of the mains valve, a braided stainless steel water line feeds the incoming water to the inlet of the boost pump.

Pump/Motor Assembly M2 (Item 2)

The pump and motor assembly boosts existing water pressure to the required 8 bar (116 psi) to properly brew espresso.

- The pump is a carbon-vane rotary pump, as used on virtually all espresso machines.
- The pump is factory set and should rarely require adjustment.
- The pump pressure can be adjusted by rotating the adjustment screw clockwise to increase the pressure and counter-clockwise to decrease the pressure.

Check Valve RV (Item 3)

Installed on the outlet fitting of the pump is a check valve, preventing any pressurized water in the Sinfonia from feeding back into the pump and mains valve.

The outlet of the check valve is equipped with a tube that feeds the incoming water to the cold water block.

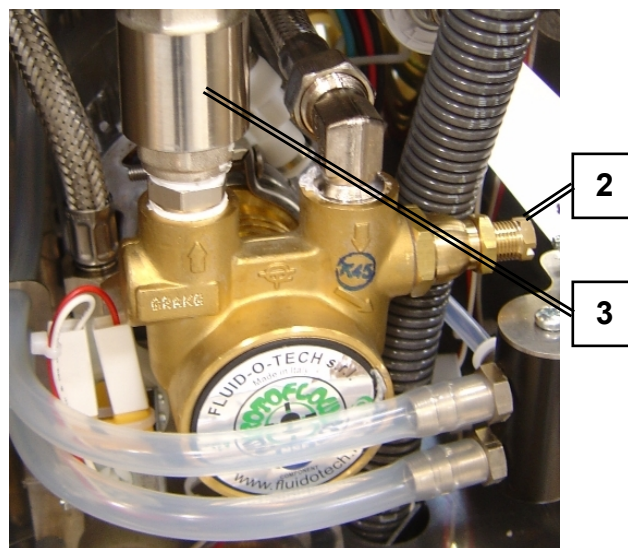

2. Pressure adjustment screw
3. Check Valve

Cold Water Valve Block (Item 4)

The cold water block receives water from the pump and supplies the components requiring cold water.

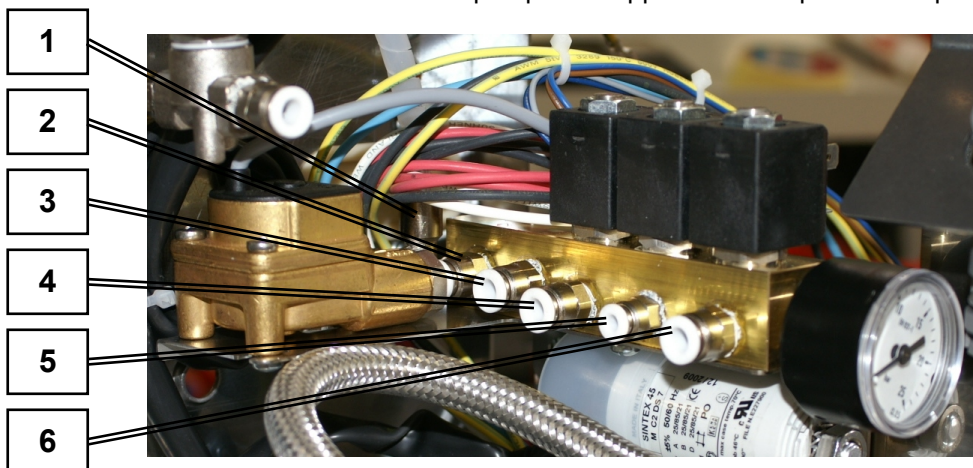

- | | |
|--|---|
| <ol style="list-style-type: none"> 1. Water from the flowmeter to the coffee boiler. 2. Water from the block into the flowmeter. 3. Water into the block from the pump. The block is equipped with three 24vdc valves | <ol style="list-style-type: none"> 4. Feeding Valve (Y5) - supplies cold water to autofill the steam boiler. 5. Cappu Clean Valve (Y30) - supplies water to rinse/clean the CF1 foaming unit. 6. Cold Water Tea Valve (Y4') - Supplies cold water to mix with the hot water tea valve. |
|--|---|

Pressure Gauge MM1 (Item 5)

The pressure gauge indicates the water pressure from the pump. The gauge displays the pressure in units called “bars”. One bar is equal to approximately 14.5 psi.

Flowmeter B8 (Item 6)

The flowmeter consists of the:

- Flowmeter body (2) - which houses the impellor.
- Impellor (3) - a plastic impellor imbedded with two small magnets (4). As water travels through the flowmeter body, it causes the impellor to spin. As the impellor spins, the imbedded magnets rotate under the flowmeter field.
- Field (1) - As the magnets pass under the field, they activate a hall-effect switch which sends a pulse signal to the control board. The number of pulses determines the volume of water that is delivered for the espresso products.

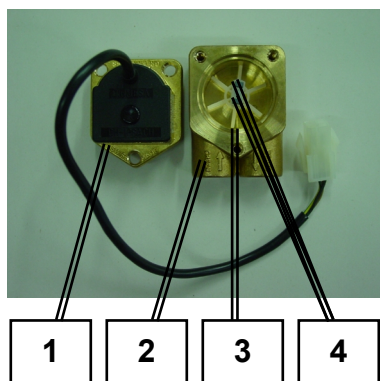

Coffee Boiler “T” Fitting (Item 7)

This “T” fitting diverts cold water to the coffee boiler and to the over-pressure relief valve.

Coffee Boiler Over-pressure Relief Valve UV (Item 8)

The coffee boiler over-pressure relief valve relieves the water pressure into the drip tray if it exceeds 12 bars +/- 1 bar.

By-pass Valve Y3 (Item 9)

The by-pass valve feeds hot water from the coffee boiler into a “y” fitting that then feeds the hot water into the coffee outlet. The by-pass valve allows the end user to produce americano beverage without having to draw water from the hot water wand.

Coffee Valve Y1

The coffee valve is located behind the brew unit, on the left hand side. The coffee valve outlet is equipped with a “male” fitting which connects to the “female” inlet on the brew unit.

The coffee valve opens to allow water to flow into the brew unit to brew espresso. The coffee valve is a 3-way valve in that it allows any pressurized water between the coffee valve and the brew unit to discharge into the drip tray when the valve closes.



Brew Unit BK

The brew unit is where water heated by the coffee boiler infuses the ground coffee to brew espresso.

- The brew unit is modular and the entire unit, along with the coffee outlet, can easily be removed from the Sinfonia for maintenance.

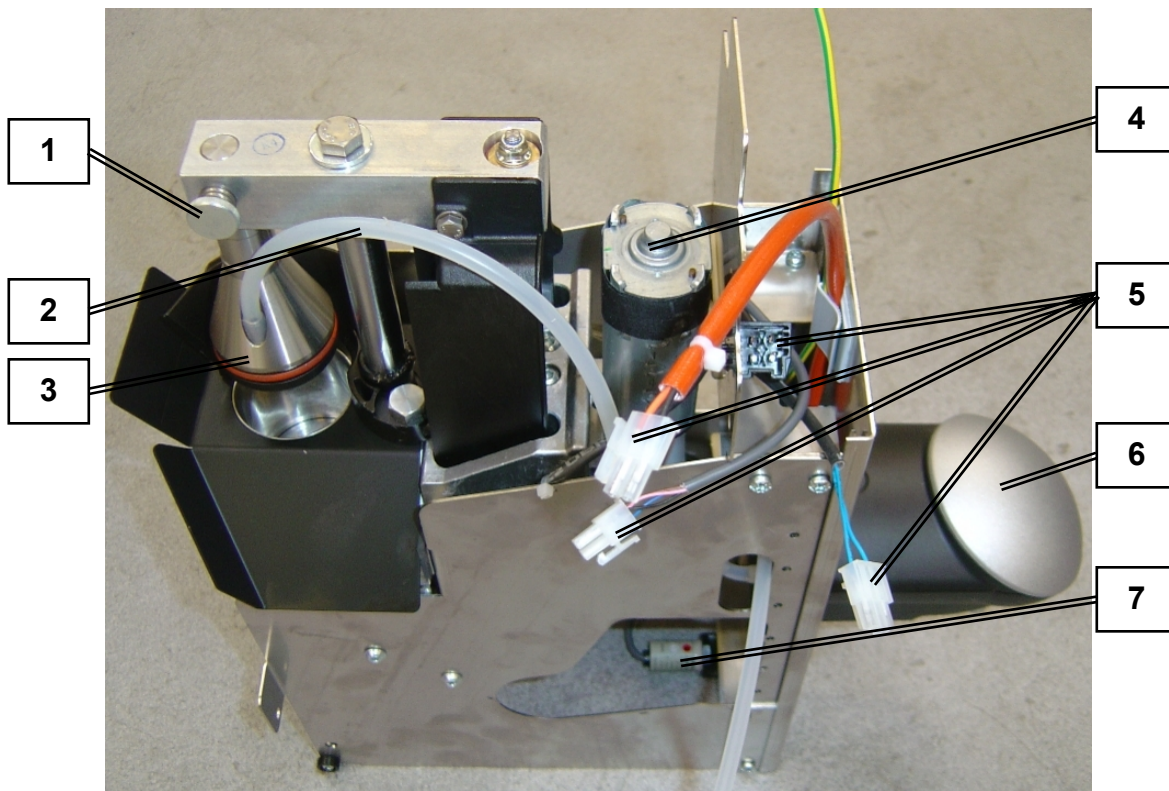

1. Thumb screw
2. Product tube
3. Upper piston

4. Piston motor
5. Piston power and micro-switch wires
6. Coffee outlet
7. Cup Sensor

Boilers

The Sinfonia is equipped with two boilers: a coffee boiler and a steam boiler.

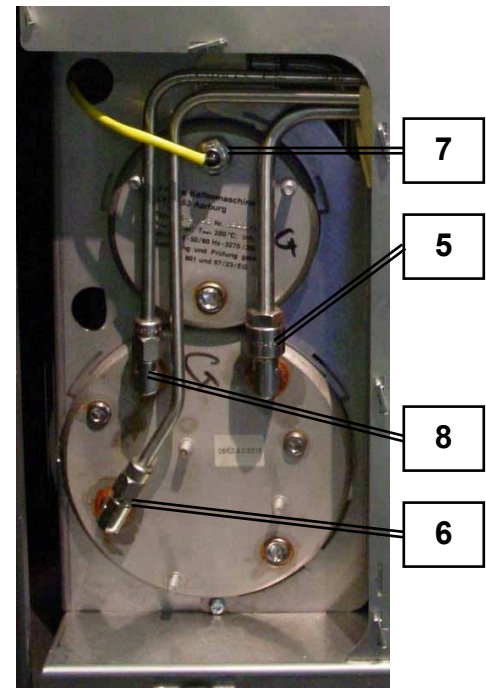
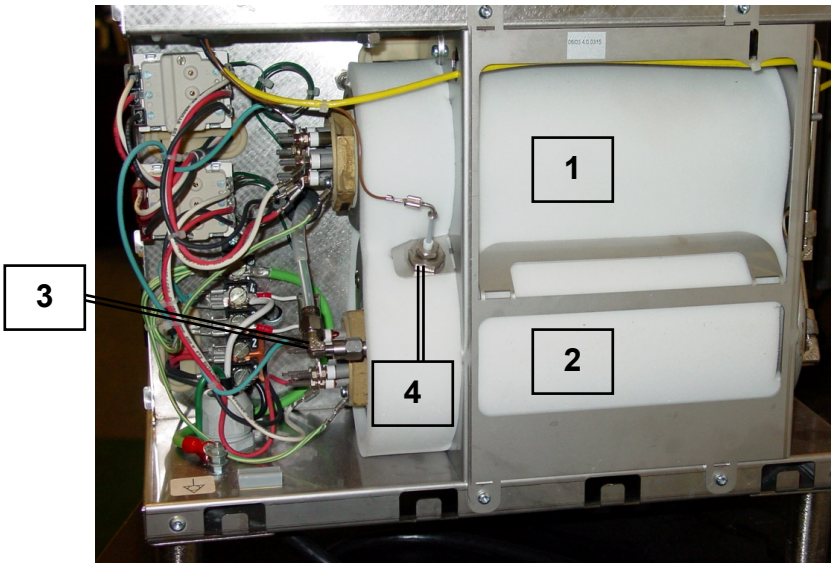

- | | |
|--|--|
| <ul style="list-style-type: none"> 1. Coffee boiler 2. Steam / Hot water boiler 3. Feed inlet 4. Auto-fill level probe | <ul style="list-style-type: none"> 5. Steam feed to pressure block 6. Hot water feed to Hot water/Steam block 7. Thermostat (NTC Temperature probe) 8. Steam feed to Hot water/Steam block |
|--|--|

Coffee Boiler E3 (Item 1)

Heats water for brewing espresso.

- The coffee boiler is completely full of water
- Cold water is fed into the boiler by a tube from the outlet of the flowmeter.
- The water in the boiler is heated to a specific, pre-programmed temperature. The temperature is measured by a thermostat imbedded into the upper left hand side of the boiler. (Item 7)
- The heated water then travels through a teflon tube to the coffee valve and then into the brew unit, when the coffee valve opens.

Steam Boiler E2 (Item 2)

Heats water to provide tea water and steam for preparing milk.

The steam boiler is fed with cold water via a teflon tube flowing from the outlet of the Y5 Steam Feeding Valve. (Item 3)

The water level in the boiler is maintained by the auto-fill probe. (Item 4)

- There are two steam outlets tubes on the left hand side of the boiler. One to feed steam to the pressure block (item 5) and one to feed steam pressure to the hot valve block (item 8)
- There is also a stainless tube, located at the lower left hand section of the steam boiler, (item 6) that feeds hot water to the hot valve block.

Auto-fill Probe B3

Auto-fill probe determines whether or not there is a sufficient level of water in the boiler.

- The metal auto-fill probe sticks down into the boiler approximately 1 3/4 inches.
- The metal auto-fill probe is energized with 1-2vac.
- As the water level rises up, it eventually touches the probe. The 1-2vac of electricity travels through the water, grounding out against the side walls of the boiler.
- As the water level lowers and drops below the probe, the ground signal is interrupted, signaling the control board to activate the feeding valve, filling the boiler with fresh water.

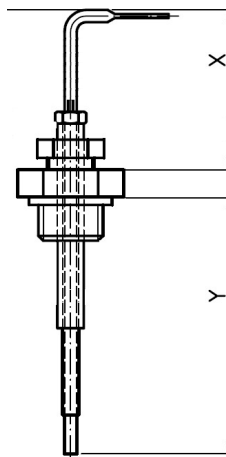

New Auto-fill Probe

- Evolution Top
- Evolution Plus
- **Sinfonia (FSA)**
- Ecopower

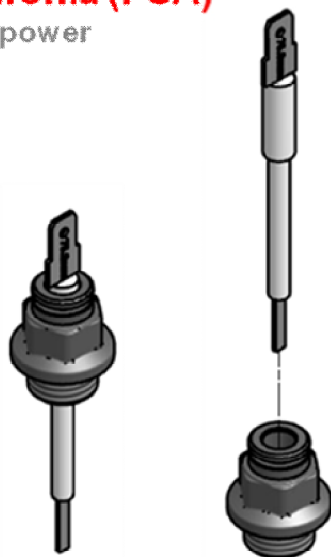

Length = 75 mm / 2.95 inches

- Evolution Basic
- Ecolino
- Swiss Mambo

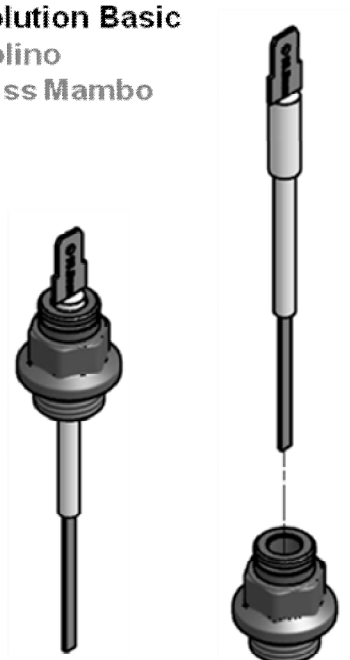

Length = 93.5 mm / 3.68 inches

Pressure Block

The pressure block is a valve block that houses four components:

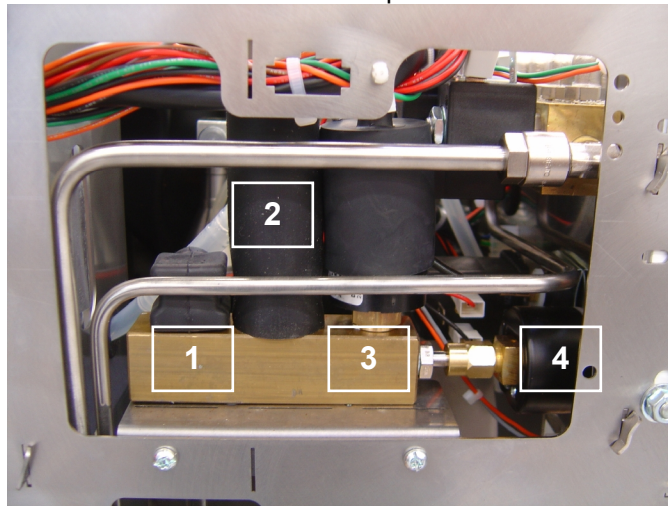

- | | |
|--------------------------|--------------------|
| 1. Vacuum breaker | 3. Pressure switch |
| 2. Pressure relief valve | 4. Pressure gauge |

Vacuum Breaker RB (Item 1)

It allows the boiler to be open to atmosphere when the machine does not contain steam pressure.

- This allows the atmospheric pressure in the boiler and in the room to equalize preventing a vacuum from forming when the boiler cools down.

Pressure Relieve Valve RU (Item 2)

- Releases the pressure in the boiler if it exceeds 2.5 bar.
- The top of the pressure relief valve partially unscrews to allow depressurization of the boiler.
Careful: Temperature exceeds 212°F !!
Ensure that the rubber cap is installed correctly at all times!!

Pressure Switch S1 (Item 3)

The pressure switch maintains the steam pressure in the boiler by opening and closing the electrical circuit to the heater relays.

Note! Adjustment of the pressure switch is not needed. Do not attempt to make any adjustment to the pressure switch. If the steam pressure is maintaining +/- .2 bars of 1.8, replace the pressure switch.

Pressure Gauge MM2 (Item 4)

The pressure gauge reads the steam pressure in the boiler. **Operational pressure for Sinfonia is 1.8 bar.**

Hot Valve Block

The hot valve block houses four 24vdc valves.

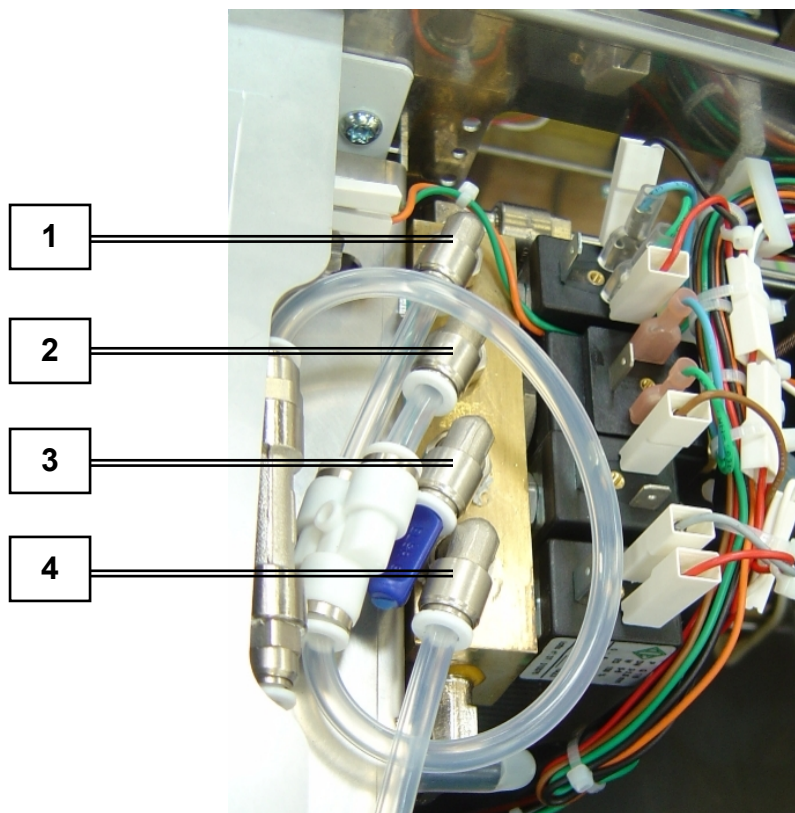

1. Y20 Cappu Steam valve
2. Y6 Steam valve 1

3. Y6' Steam valve 2 (not used)
4. Y4 Hot Tea valve

Y20 Cappu Steam Valve (Item 1)

The cappu steam valve provides steam pressure to the foaming unit to steam milk.

Y6 Steam Valve 1 (Item 2)

Steam valve 1 provides steam pressure to the foaming unit together with the cappu steam valve.

Y6' Steam Valve 2 (Item 3)

Steam valve 2 is not used in the Sinfonia FSA.

Y4 Tea Valve (Item 4)

The “hot” tea valve opens in conjunction with the Y4’ “cold” tea valve every time a rinse or clean cycle is selected. Hot water is cycled out of the hw/steam boiler to circulate fresh water into the boiler.

Legend: Waterflow Diagram

B3	Steam Level
B4	Probe Coffee
B8	Flowmeter Coffee
BK	Scalding head (SC)
BLx	Orifice
E2	Heater Tea/Steam
E3	Heater Coffee
E6	Heater SC
K	Coffee Boiler
M2	Pump
MM1	Manometer 25bar
MM2	Manometer 4bar
P1/P2	Pump Milk 1 and 2
RB	Valve Vacuum
RU	Valve Safety Overpressure 2.5bar
RV	Valve non return Water Pumpe
S1	Steam Pressure Switch
T/D	Tea/Steam Boiler
UV	Valve Safety Overpressure 11bar
Y1	Valve Coffee
Y3	Valve By-Pass (breakfast)
Y4/4'	Valve Tea (hot valve and cold valve)
Y5	Valve Steam Feeding
Y6/6'	Valve Steam1/Steam2
Y20	Valve Steam Cappu
Y30	Valve Cappu-clean
Y31	Valve Air Cappu
Y33	Valve General (Main water valve)
Y35	Valve non return Steam
Y36	Valve non return milk

Sinfonia FSA One-Step MUT Milk System

Franke has designed a milk system that allows two separate types of milk to be supplied to the Sinfonia. The milk containers are housed in a small refrigerator which sits underneath the machine, hence the designation "Milk Under Table", or MUT

Some advantages of the MUT milk system are:

- The ability for "One-Step" preparation of milk-based espresso beverages with the option of selecting two different types of milk.
- The ability to draw from higher volume of milk decreasing the need to re-fill or replace empty milk containers.
- A smaller "foot print" on the counter, as the refrigerator and milk are below the counter.

CF components

Double Pinch Valve

In the CF system, milk foam is created by means of a pinch valve (Y31) opening, allowing air to enter into the foaming unit. When air is introduced to milk while steaming, it creates foam.

Check Valve Body

The check valve (Y20) outlet on the FSA is NOT equipped with a check valve. The check valve body is used only as a "T" to allow steam to go to the milk pumps and to the foamer head at the same time.

The check valve body has a 1.5mm XFMS restrictor installed to reduce the amount of steam that flows to the milk pump for rinsing and preheating.

- 1. Pinch Valve
- 2. Check Valve Body
- 3. Restrictor
- 4. Air Nozzle

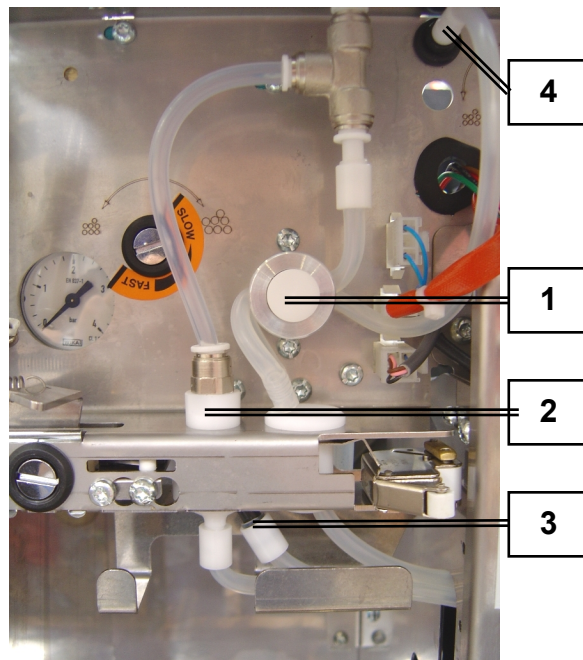

Outlet Nozzles

- 1. Coffee Outlet Nozzle
- 2. Air / Steam Outlet Nozzle
- 3. Steam Outlet Nozzle with Check Valve
- 4. Milk Outlet Nozzle

Remember;
Coffee
Air
Steam
Milk

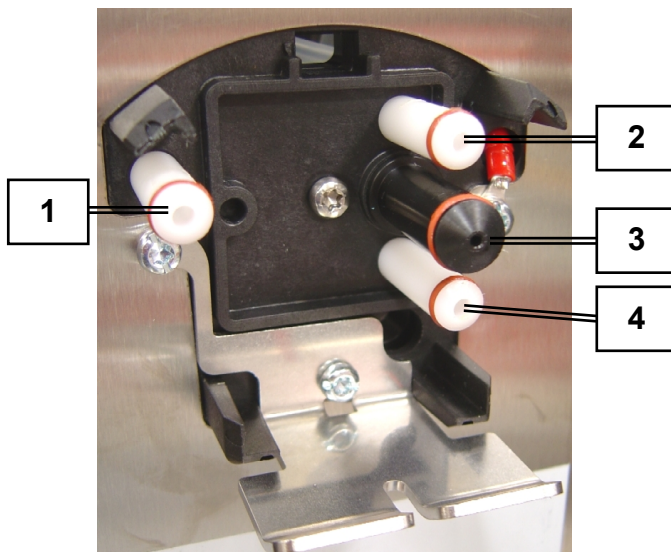

CF Foaming Unit

The CF (Cappuccinatore Franke) foaming unit is where the steam, milk and air come together to produce warm milk and milk foam in Cappuccinos and Lattes.

1. Cappuccino Cover
2. Air Check Valve
3. Cappuccino Foamer Unit
4. Air / Steam / Inlet
5. Steam Inlet
6. Milk Inlet
7. Inline Steam Check Valve

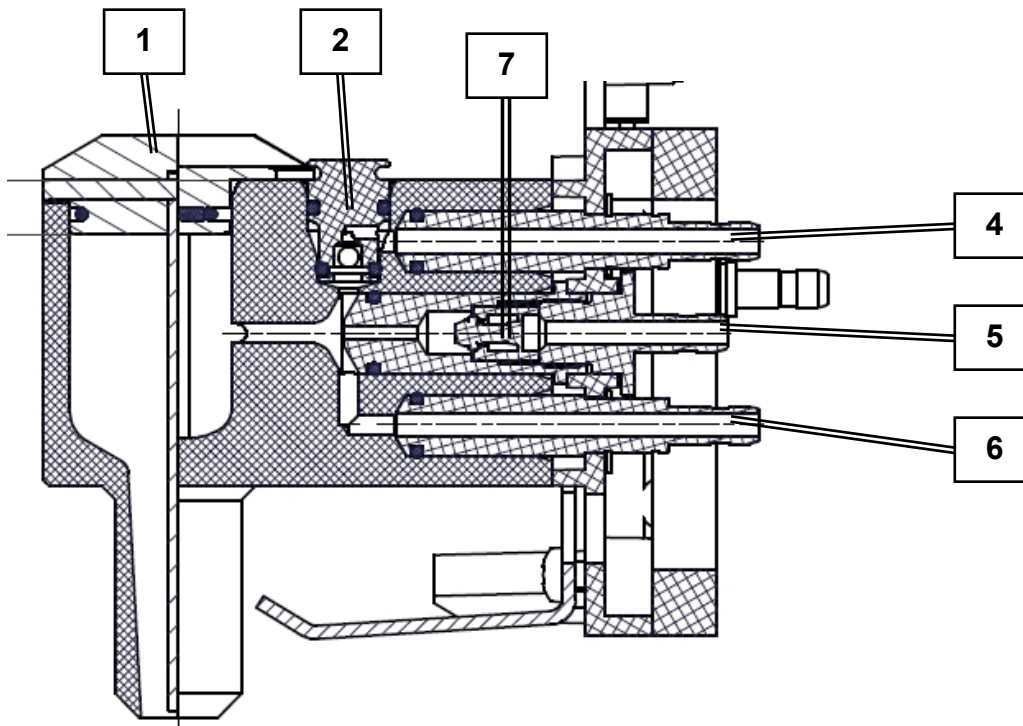
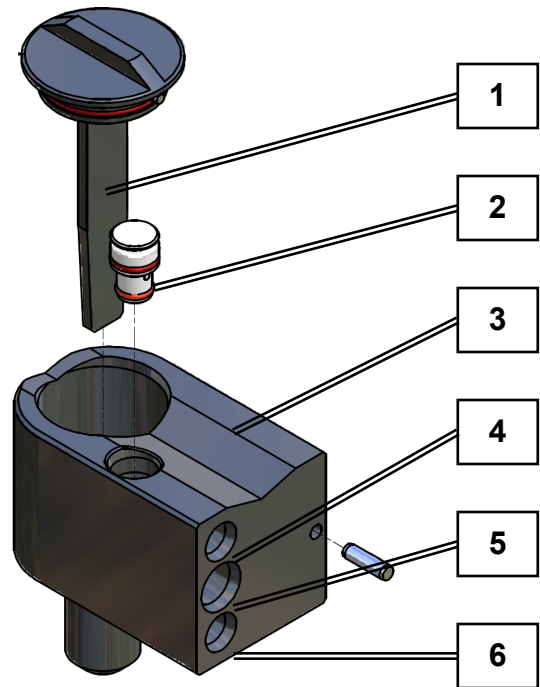

MUT 4 FSA Milk System CF

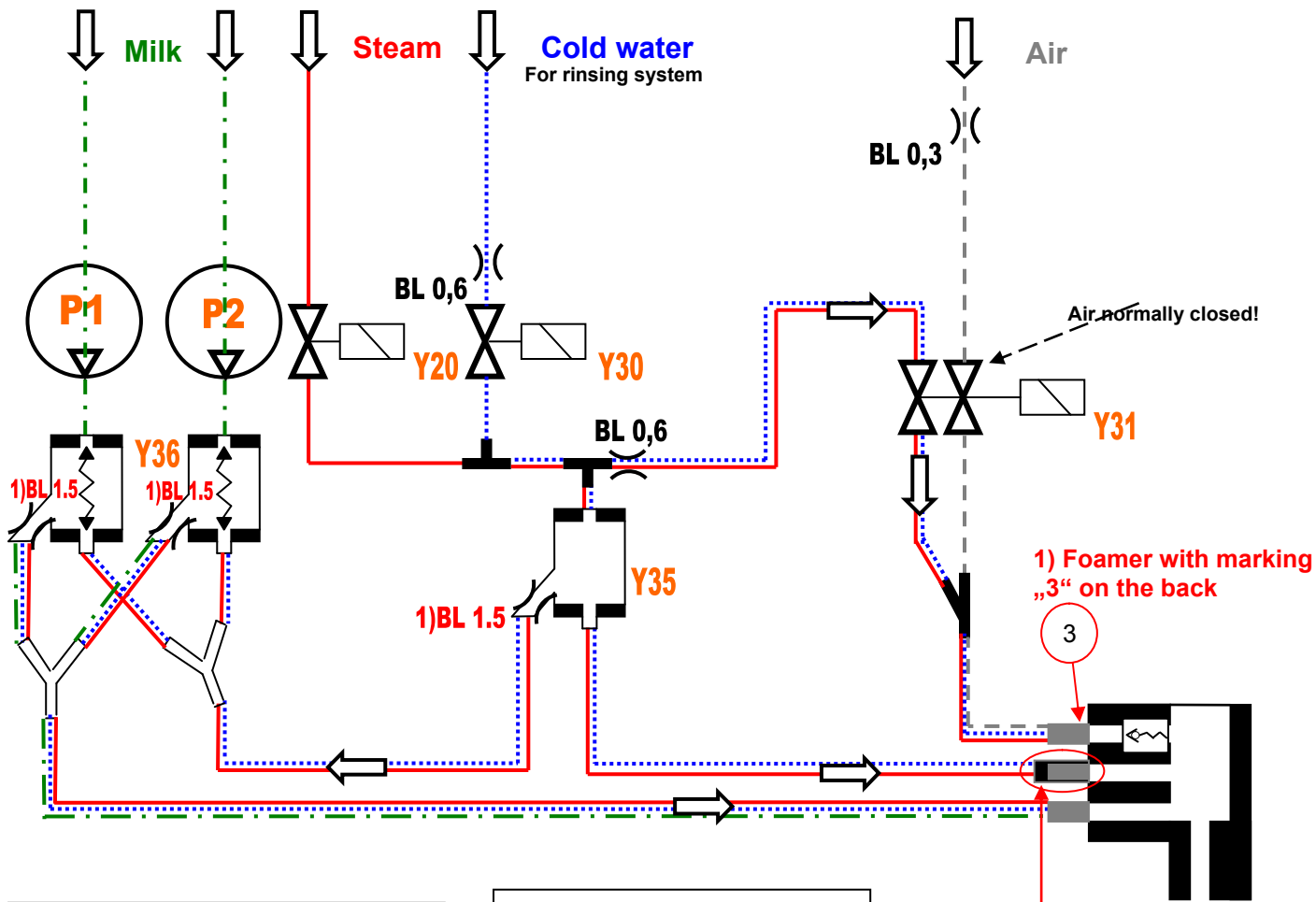

CF

- Foamed milk / Mousse lait
- Hot milk / Lait chaud
- Cold milk / Lait froid

1) BL 1.x XFMS Orifice

- Y20** Valve steam cappu
- Y30** Valve cappu clean
- Y31** Double pinch valve
- Y35** Valve non return steam
- Y36** Valve non return milk
- P1** Pump 1
- P2** Pump 2

1) Coupling 1.8mm black with non return valve



Franke Sinfonia FSA

Technical Training Manual

Electrical System and Schematics – Chapter 8

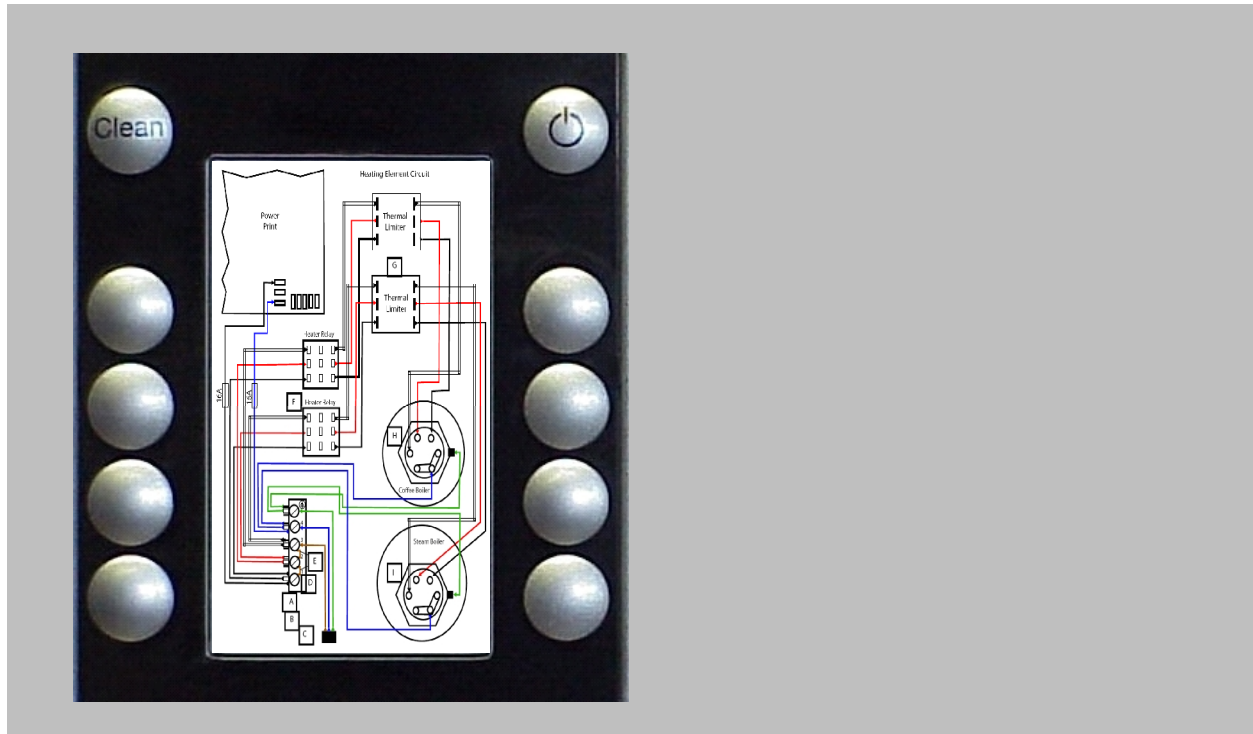

Franke Coffee Systems
800 Aviation Parkway
Smyrna, TN 37167
(615) 462-4000

Change log

Date	Changes	Author	Change No.	ID
2009-07-20	New Manual Concept	MPH		
2010-03-01	Update Schematics Bag Milk (BiB)	MPH		A
2010-09-28	Update electrical wiring color scheme	MPH		B

Publisher:

Franke Kaffeemaschinen AG
 P.O. Box 235
 CH-4663 Aarburg
 Switzerland

www.franke-cs.com

Table of Contents

Change log	2
Table of Contents	3
Safety Notes	4
Safety	5
 Electrical System	5
Electrical System	6
High Voltage System.....	7
High Voltage Wiring.....	7
Main power cord	8
Pump Motor	8
Grinder motors.....	8
Heating Element	8
Brew Unit Block Heater.....	8
Step-down Transformer	9
Heating Element Circuit.....	10
A - Switched Leg	10
B- Un-switched Leg	10
C - Ground Wire	10
D - Terminal Block	10
E - Jumpers	10
F - Heater Relays	10
G - Thermal Limiters	10
H - Coffee Boiler	10
I - Steam Boiler	10
Power Board Wiring (Low voltage and High voltage).....	12
Wiring Diagrams.....	16
Contents	16
Legend.....	16
MUT Electrical Components	24
Milk Print Schematics.....	25
Jumper 4 (JP4).....	25
MUT Milk pumps.....	25

Safety Notes

The installation, setting, repair and maintenance work described in these instructions must be performed only by service technicians trained by Franke Coffee Systems Americas Inc. and when using original Franke parts!

Observe the following dangers and warnings when servicing coffee machines with live voltage.



DANGER!

Indicates potentially life threatening Danger!
Electrocution caused by coming in contact with live voltage.
Safeguard parts with live voltage against contact.



WARNING!

Indicates risk of injury!
You may suffer injuries due to moving parts crushing fingers and hands.
Secure moving parts against unintentional movement.



CAUTION!

Indicates risk of minor injury!
Avoid burns caused by hot water, steam, hot milk, or milk foam



NOTE!

Indicates possibility of damage to the machine.

Safety

**DANGER*****Electrical System***

Before performing maintenance on any electrical related component, ensure the following:

- Always disconnect from its power source before opening the machine.
- Ensure that the machine cannot be accidentally turned ON.
- Never operate a machine that has been damaged or has a damaged power supply cable.
If the power supply cable to this machine is damaged, it must be replaced with an original power cord.
- Ensure that the machine and power cord are not near any hot surfaces such as gas or electric stoves or ovens.
- Ensure that the power cord is not pinched and does not rub against sharp edges. The machine contains electrically conductive parts. Opening the machine can pose risk of death.
- Do not make any modifications to the machine that are not described in the documentation from Franke.
- Repairs should only be made using original replacements and accessory parts.

Electrical System

The electrical system can be separated into three sections:

- High Voltage
- Low Voltage
- Logic Bus

High Voltage System

High Voltage Wiring

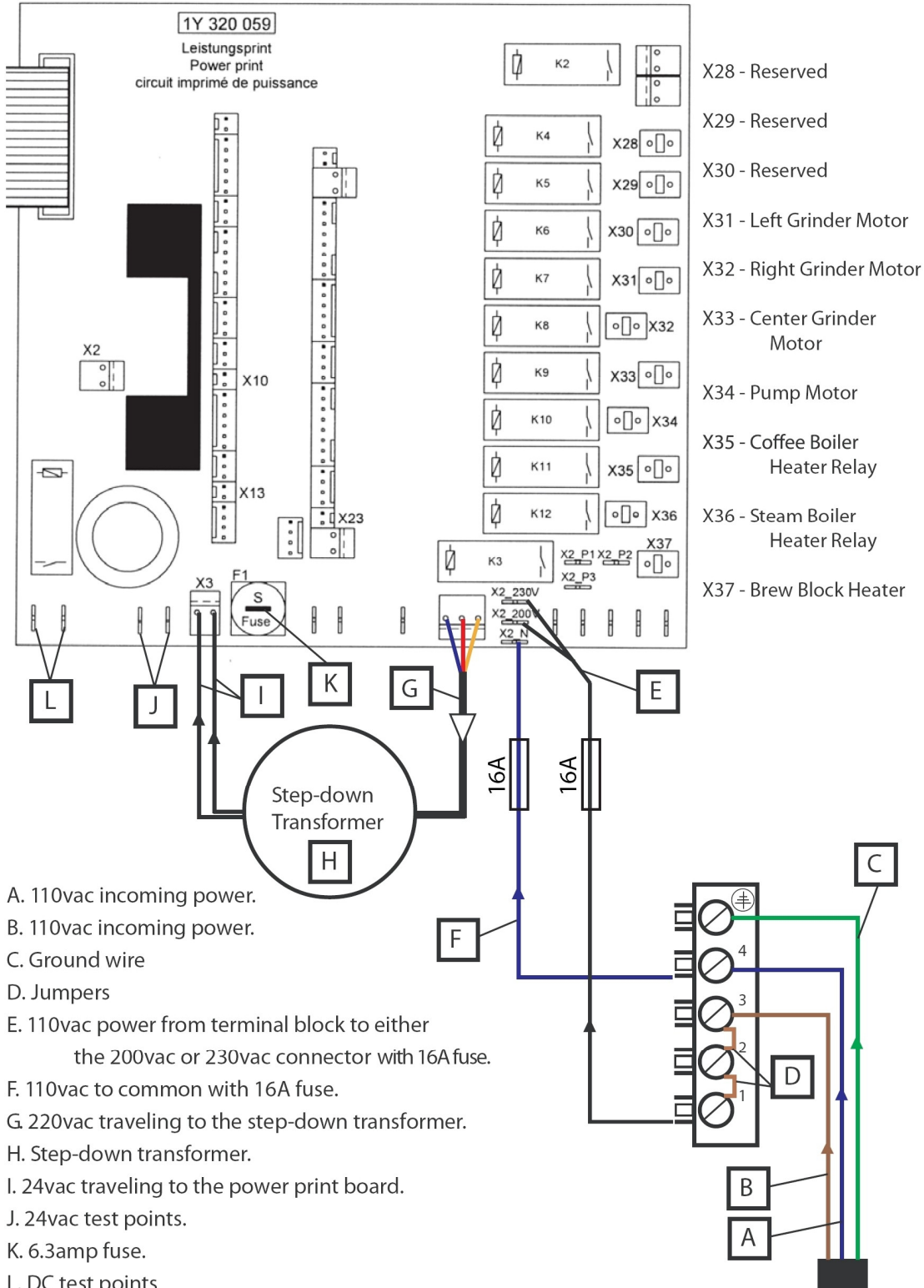

The high voltage system consists of the:

Main power cord

The power cord is a 12-3 cord (white, black & green), carrying 230Vac.

- The power cord travels from the wall outlet to a terminal block located near the rear, right-hand side of the machine.
- A voltage filter is installed onto the terminal block to prevent frequency interference.

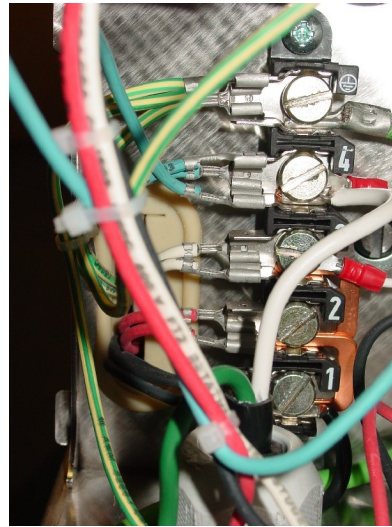

Pump Motor

The pump motor is an air-cooled 230vac motor that spins the pump head to boost incoming water pressure.

- The motor is a capacitor-start motor that is “jump-started” by a 7 μ F (microfarad) capacitor.

Grinder motors

Each grinder is powered by a 230Vac motor.

- The grinder motors are capacitor-start motors and are “jump-started” by a 16 μ F (microfarad) capacitor.

Heating Elements

The Sinfonia has two different heating elements. One for the coffee boiler and one for the steam boiler.

- The coffee boiler element has three legs rated at 230 volts, 3000 watts total, 52.8 Ohms.
- The steam boiler has three legs, rated at 230 volts, 4500 watts total, 39.4 Ohms.
- The heating elements are not interchangeable.



Brew Unit Block Heater

The brew unit is equipped with a 230vac, PTC (Positive Thermal Coefficient) ceramic heater that heats the brew block to 60°C +/- 10% (140°F)

Step-down Transformer

The step-down transformer steps 230Vac down to 24Vac to supply the rectifier for conversion of AC voltage into DC voltage.

- The step-down transformers output voltage can be changed by placing the switched leg from the terminal block onto one of two input connectors on the power board.
- The transformer will output less voltage if the jumper is plugged into the 230V connector.
- The transformer will output more voltage if the jumper is plugged into the 200V connector.
- Incoming Voltage measured between 216V to 240V, use X2_230V connector on power board.
Incoming Voltage measured between 200V to 215V, use X2_200V connector on power board.

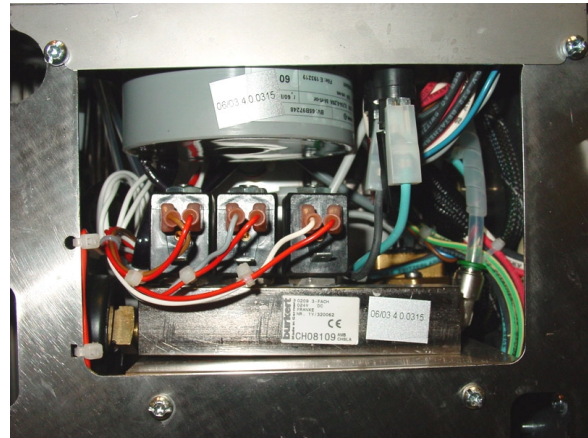

Heating Element Circuit

A - Switched Leg

- The brown wire is one leg of 230Vac from the incoming power cord to position #3 on the terminal block.
- This single black wire is then jumped to positions #2 and #1 to provide three separate legs of 110V.
- These three legs, white, red, and black, then leave the terminal block and travel up to incoming positions on the two heater relays.
- There is an additional black wire leaving the # 1 position of the terminal block that travels up to the power print board to supply the board with one leg of 230Vac.

B- Un-switched Leg

- The white wire is the second leg of 230Vac from the incoming power cord to position # 4 on the terminal block.
- Leaving the terminal block is 3 separate blue wires.
- One blue wire travels to the coffee boiler heating element, where it supplies one leg of constant 110V.
- The second blue wire travels to the steam boiler heating element, where it supplies one leg of constant 110V.
- The third blue wire travels up to the power print board where it supplies the second leg of 230V required to power the machine's other high voltage components.

C - Ground Wire

- The green wire travels to the "ground" position of the terminal block and then leaves the terminal block as four separate wires.
- Two wires travel to the heating elements.
- One travels to the power print board.
- The fourth wire travels up to the machines ground terminal.

D - Terminal Block

- Receives the incoming power from the main power cord and then distributes the power appropriately.

E - Jumpers

- Takes the incoming 110V from the black wire and distributes it to positions # 2 and # 1.

F - Heater Relays

- Receive power from the terminal block. When the relay is closed, by power from the K11 or K12 relays on the power print, the power then travels from the relay to the thermal limiters, and then to the three legs of the heating element.

G - Thermal Limiters

- Are designed to open the electrical circuit to the heating elements if the temperature in the boilers exceeds 165 Celsius.

H - Coffee Boiler

I - Steam Boiler

J - Power Print Board

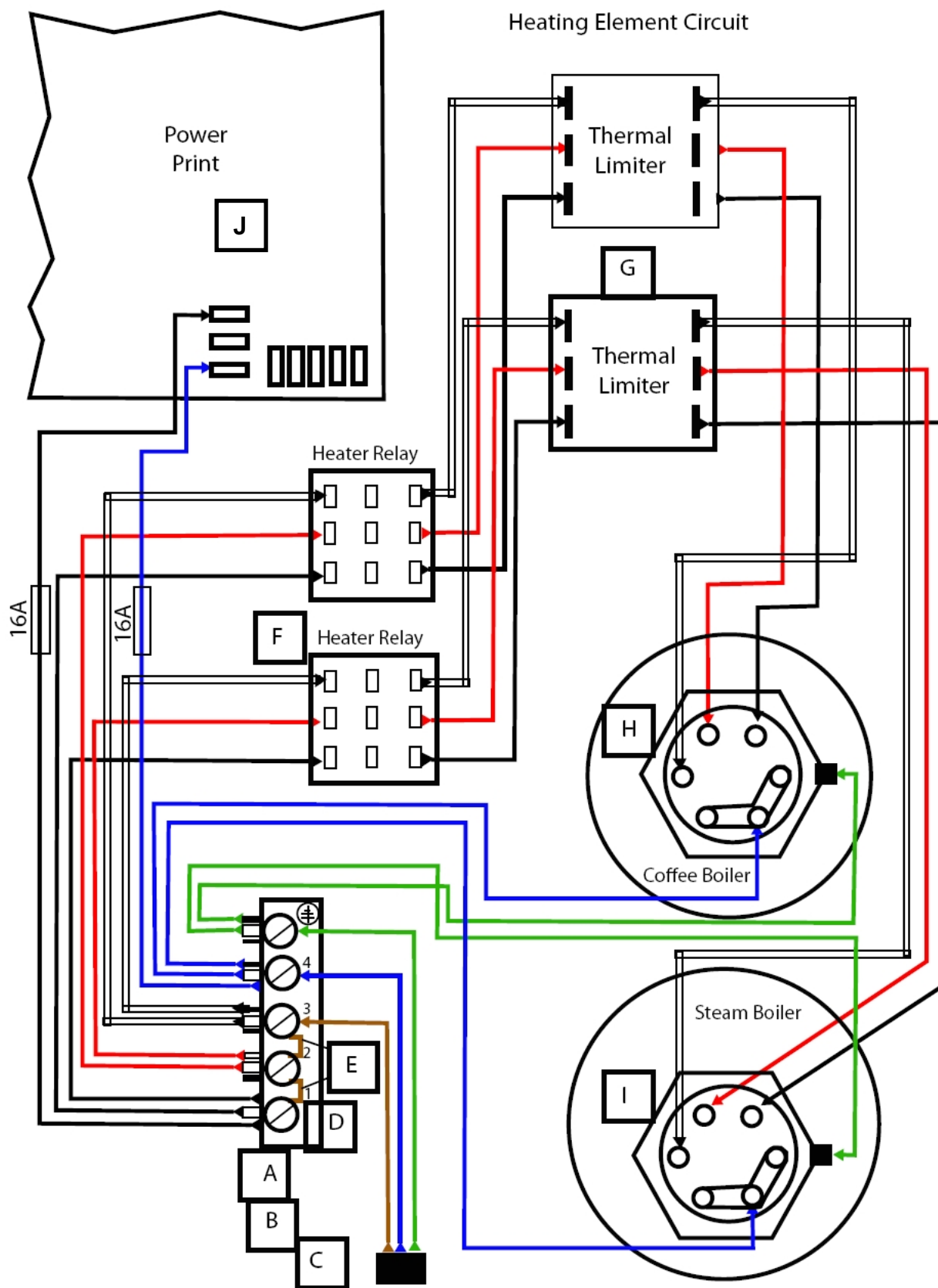

Power Board Wiring (Low voltage and High voltage)

AC power traveling from the step-down transformer is converted into dc voltage by the rectifier. This dc voltage is used to power all of the solenoid valves on the machine as well as the brew piston motor.

The 24Vdc components are powered by triacs. The diagram below indicates which triac powers which component.

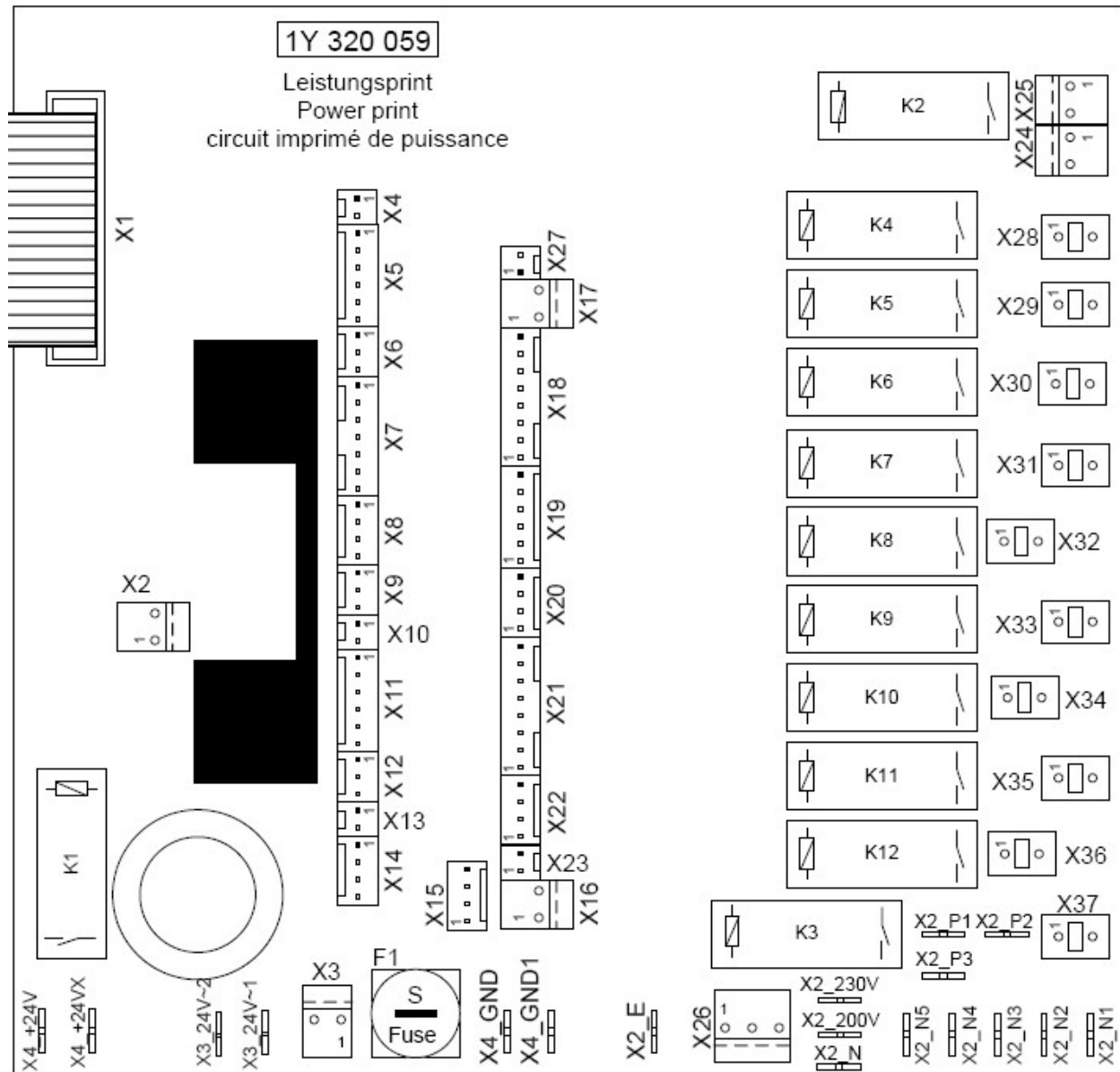

Connector	Pin Number	Wire Color	Description / Function
X2	1	green	Brew group motor
	2	black	Brew group motor
X3	1	white	24VAC from stepdown transformer
	2	white	24VAC from stepdown transformer
X4	1	red	Brew unit increment reader
	2	brown	Brew unit increment reader
X5	1	black	Coffee outlet input
	2	orange	+24V
	3	gray	Grounds container door input
	4	orange	+24V
	5	green	Front door panel input
	6	orange	+24V
X6	1	orange	+24V
	2	green	Cup sensor
	3	black	Ground
X7	1		Reserve input (empty)
	2		+24V (empty)
	3	white	Pressure switch
	4	orange	+24V
	5		Reserve input (empty)
	6		+24V (empty)
	7	brown	Auto-fill probe input
X8 (not used)	1		Accounting system input
	2		+24V
	3		Reserve input
	4		+24V
X9	1	orange	+24V
	2	yellow	Milk level sensor input
	3	black	Coffee outlet input
X10 (not used)	1	black	Fresh water tank input (if used)
	2	orange	+24V Fresh water tank
X11 (not used)	1		Reserve input
	2		+24V
	3		Reserve input
	4		+24V
	5		Reserve input
	6		+24V
X12	1	white	Ground
	2	brown	Flowmeter input
	3	red	+5V

Connector	Pin Number	Wire Color	Description / Function
X13 (not used)	1		Reserve input
	2		Reserve input
X14 (not used)	1		Reserved for optical sensor input
	2		Reserved for optical sensor input
	3		Reserved for optical sensor input
	4		Reserved for optical sensor input
X15 (not used)	1		Reserved for optical sensor input
	2		Reserved for optical sensor input
	3		Reserved for optical sensor input
	4		Reserved for optical sensor input
X16 (not used)	1		Reserve output 1
	2		+24V
X17 (not used)	1		Reserve output 2
	2		+24Vx
X18	1	white	Steam valve 1 output (Y6)
	2	red	+24Vx
	3	brown	Steam valve 2 output (Y6')
	4	red	+24Vx
	5	black	Cappu Steam valve output (Y20)
	6	red	+24Vx
	7	grey	Hot Water Tea valve output (Y4)
	8	red	+24Vx
X19	1		Outlet switch output (empty)
	2		+24Vx (empty)
	3		Reserve output 3 (empty)
	4		+24Vx (empty)
	5	black	Air valve output (Y31)
	6	red	+24Vx
X20 (not used)	1		Reserve output 4
	2		+24Vx
	3		Reserve output 5
	4		+24Vx
X21	1	white	Feeding valve output (Y5)
	2	red	+24Vx
	3	grey	Cappu rinse output (Y30)
	4	red	+24Vx
	5	brown	Cold Water Tea (by-pass) valve output (Y4')
	6	red	+24Vx
	7	white	Coffee valve output (Y1)
	8	brown	+24Vx

Connector	Pin Number	Wire Color	Description / Function
X22	1	white	Mains valve output 4
	2	red	+24Vx
	3	green	By-pass valve output 4
	4	red	+24Vx
X23 (not used)	1	white	Reserve output 6
	2	red	+24Vx
X24	1	grey	Cold milk pump 2
	2	white	Cold milk pump 2
X25	1	red	Cold milk pump 1
	2	blue	Cold milk pump 1
X26	1	blue	Primary power to Step Down Transformer
	2	red	200V
	3	orange	230V
X27 (not used)	1		
	2		
X28 (not used)	1		
	2		
X29 (not used)	1		
	2		
X30 (not used)	1		
	2		
X31	1	brown	Grinder left
	2	blue	Grinder left
X32	1	brown	Grinder right
	2	blue	Grinder right
X33	1	brown	Grinder middle
	2	blue	Grinder middle
X34	1	brown	Water pump
	2	blue	Water pump
X35	1	brown	Heater relay coffee (LR1)
	2	blue	Heater relay coffee (LR1)
X36	1	grey	Heater relay tea/steam (LR2)
	2	blue	Heater relay tea/steam (LR2)
X37	1	black	Brew unit heater
	2	blue	Brew unit heater

Wiring Diagrams

Contents

Mains	463464
Outputs	466517
Outputs Cappu	466516
Inputs	463285
Overview	466511
CPU board with Flash Memory	463289
Output 230 V~	463265
MUT4 Speed	464426
MUT4 Speed BiB	469497

Legend

bn	brown
rt	red
or	orange
gb	yellow
gn	green
bl	blue
gr	grey
ws	white
sw	black
vio	violet

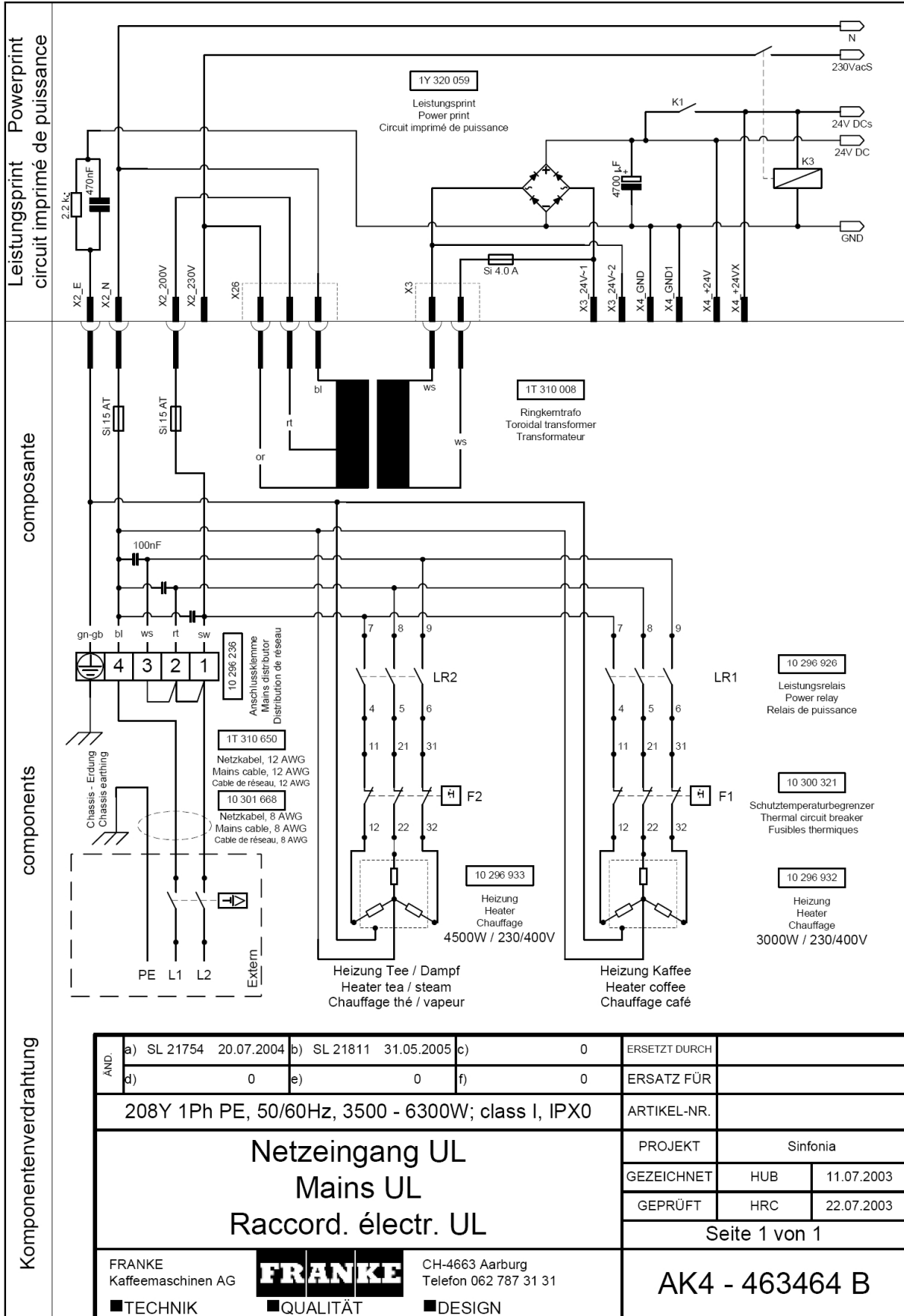

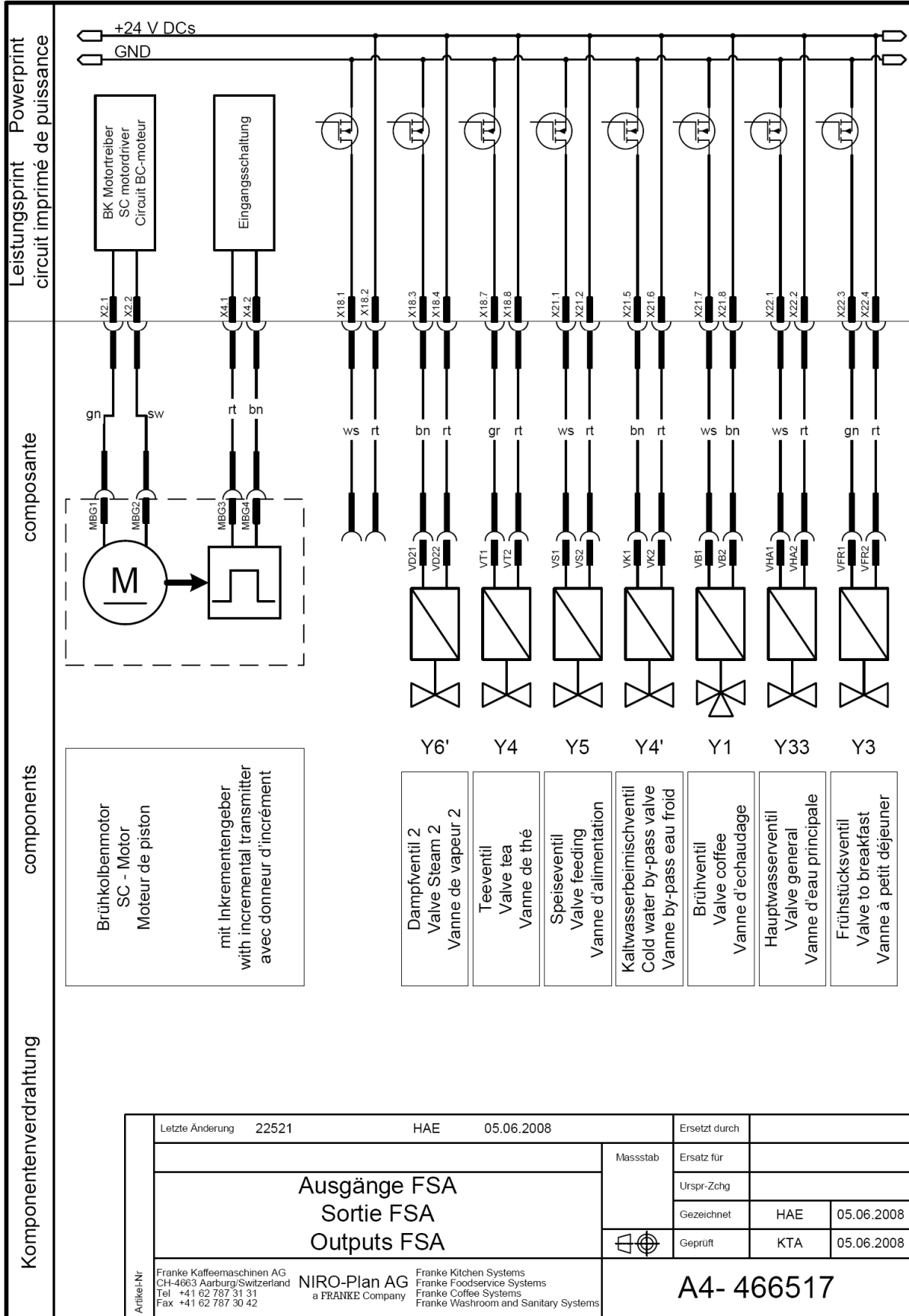

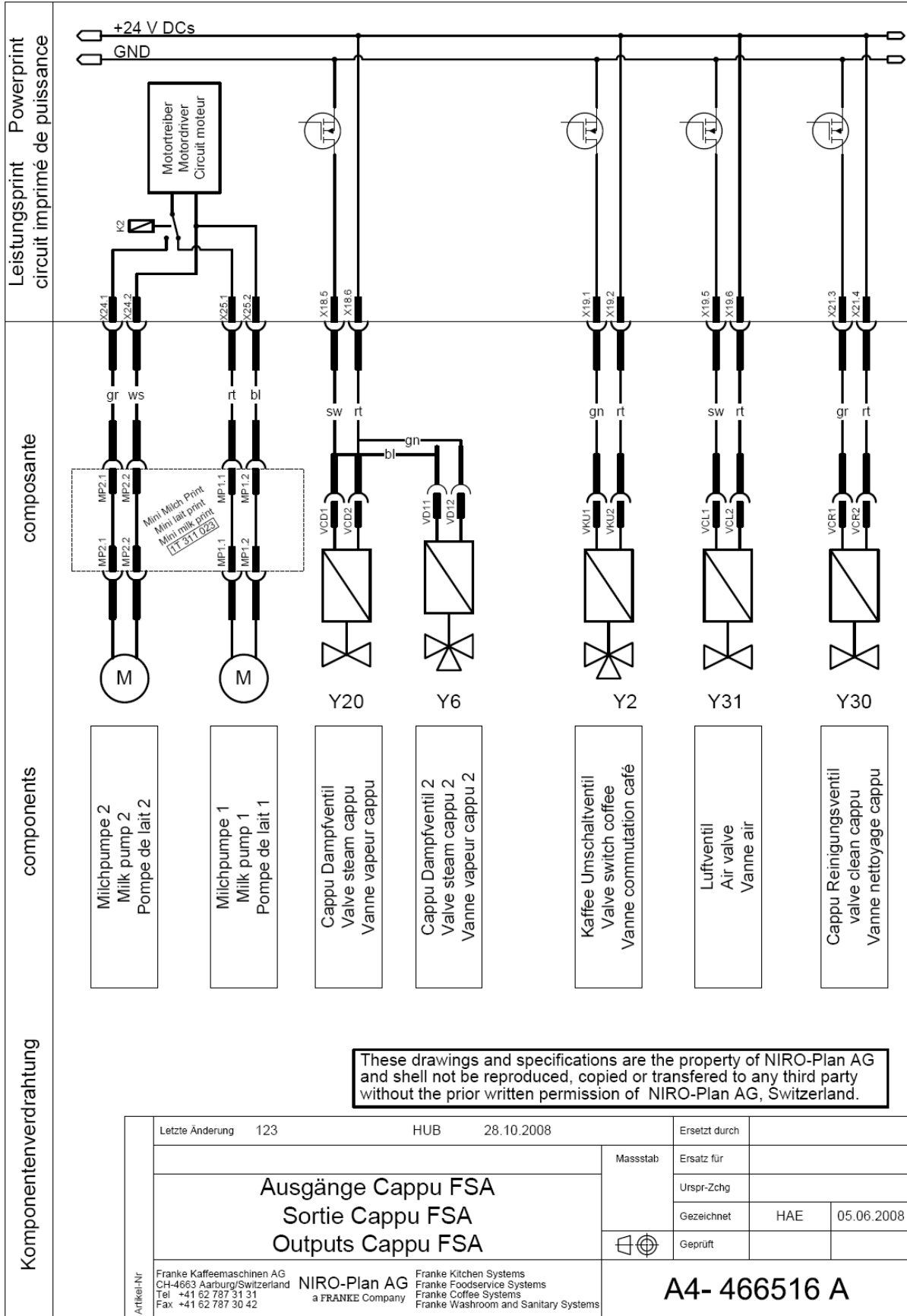

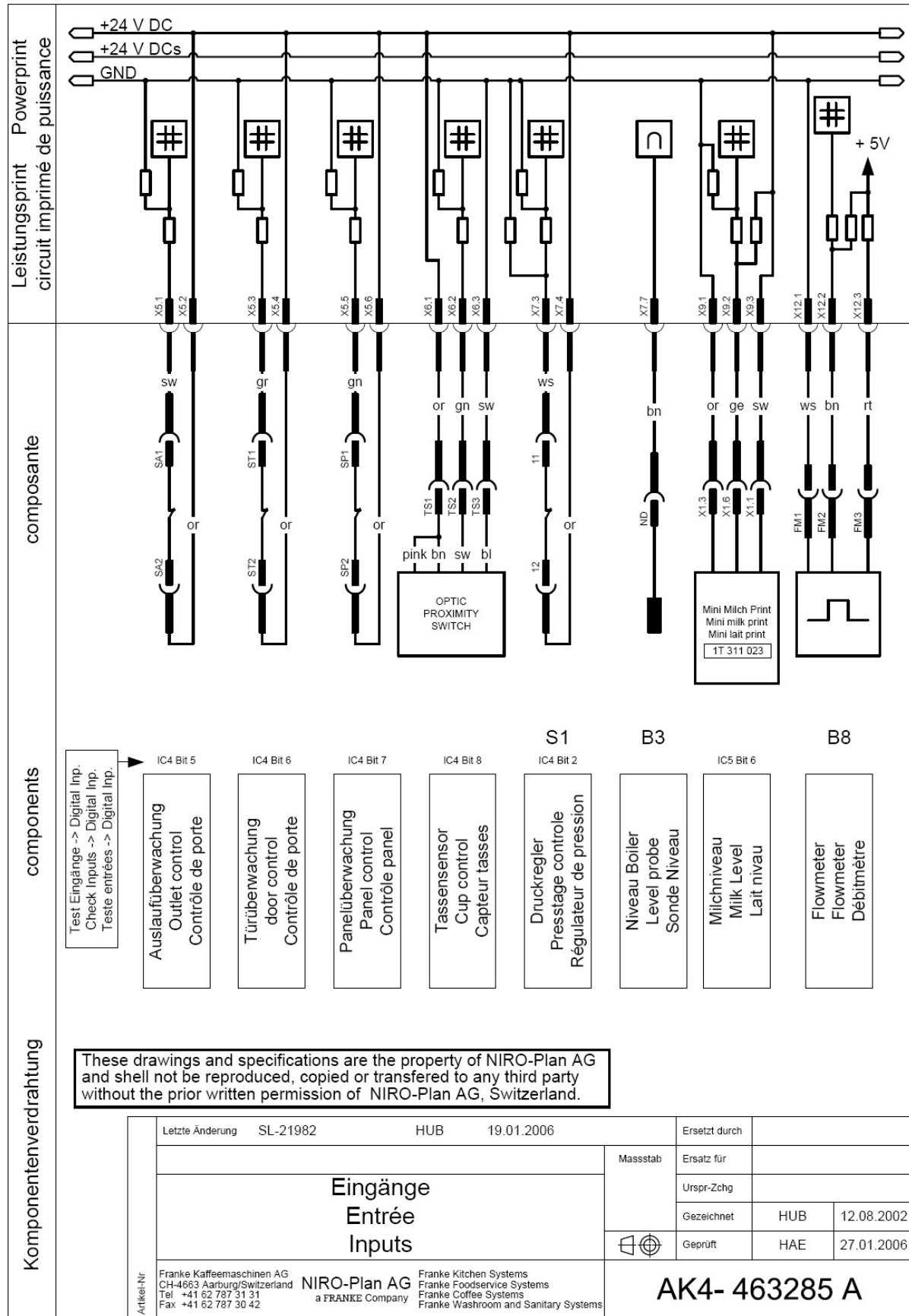

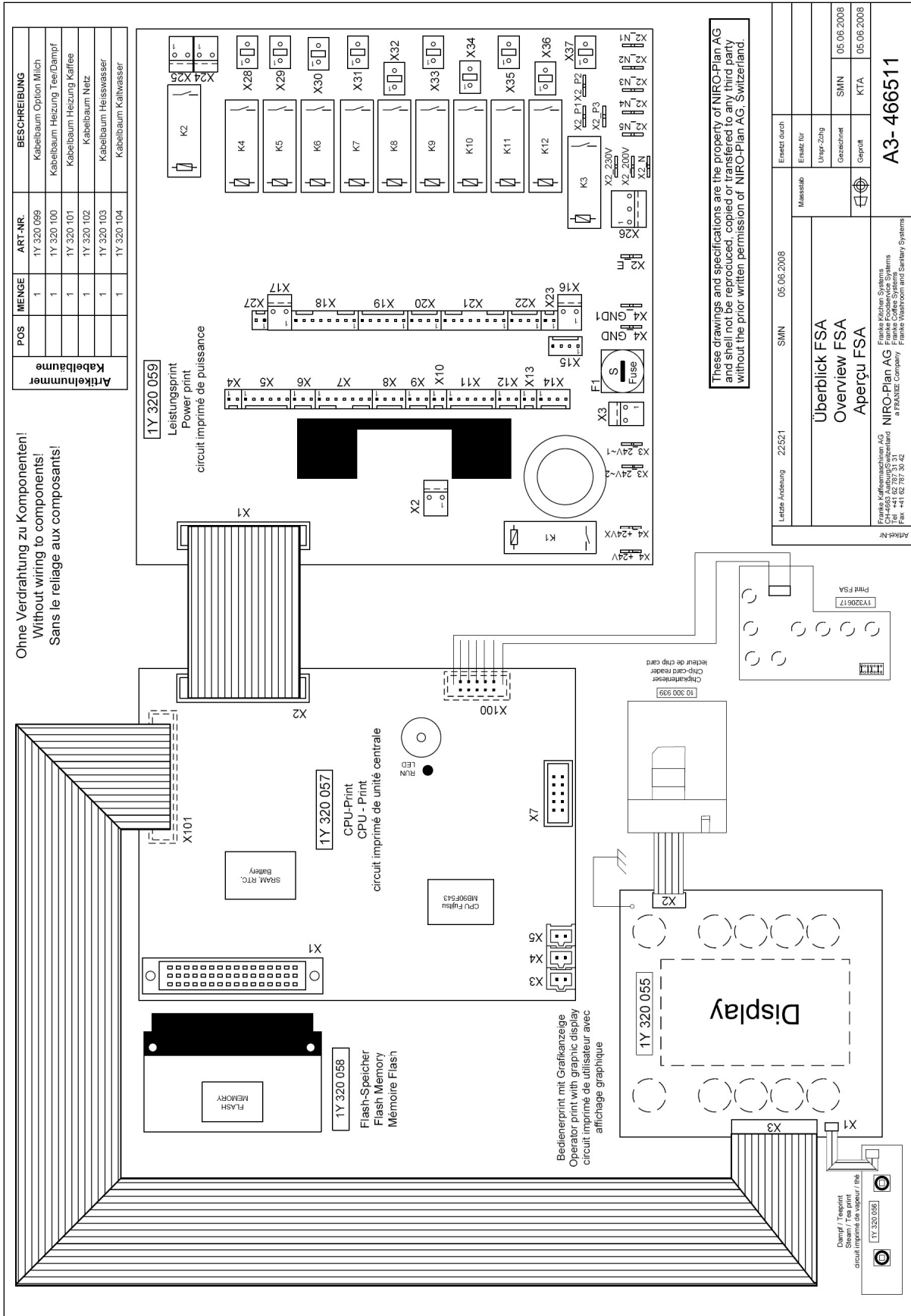

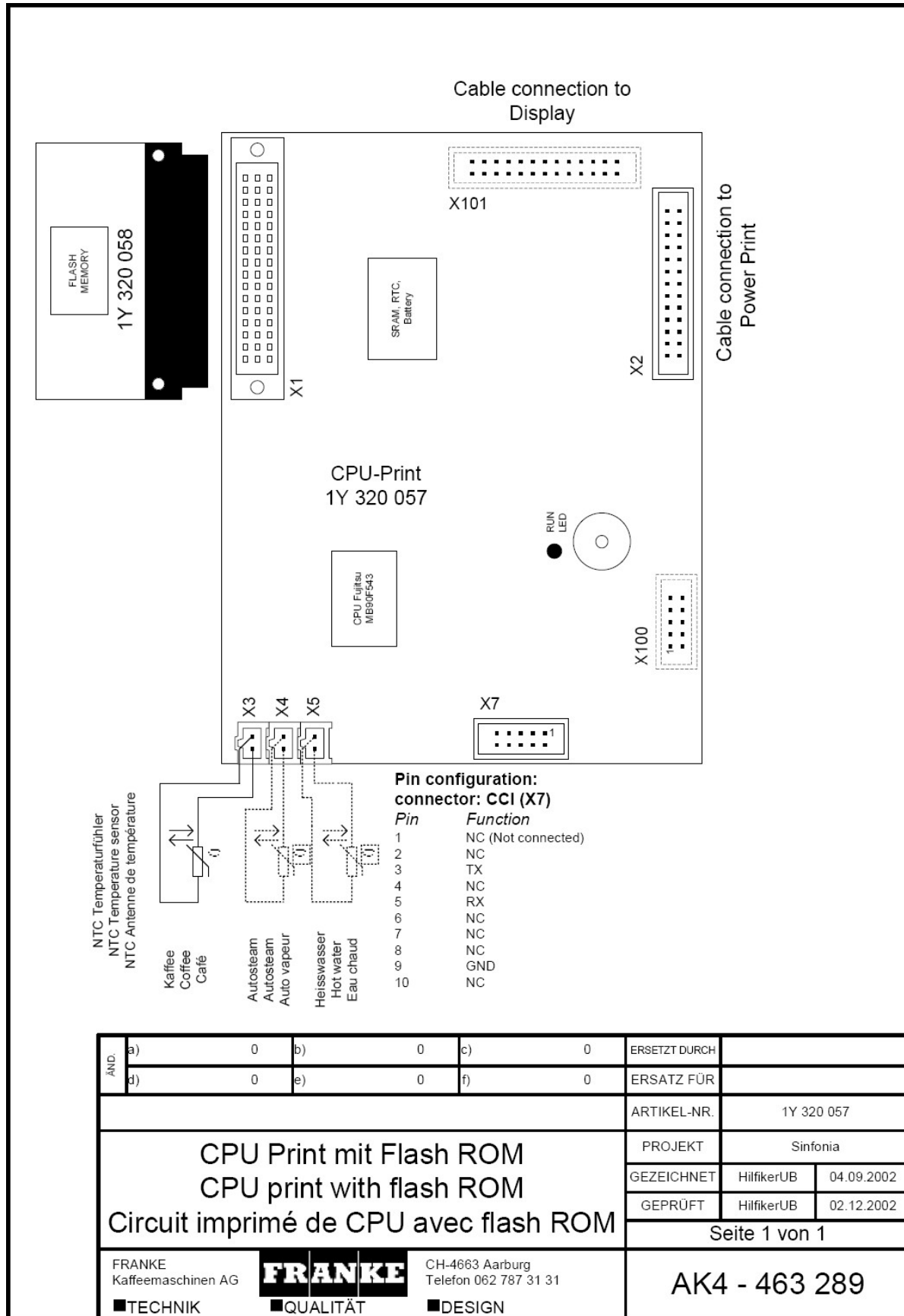

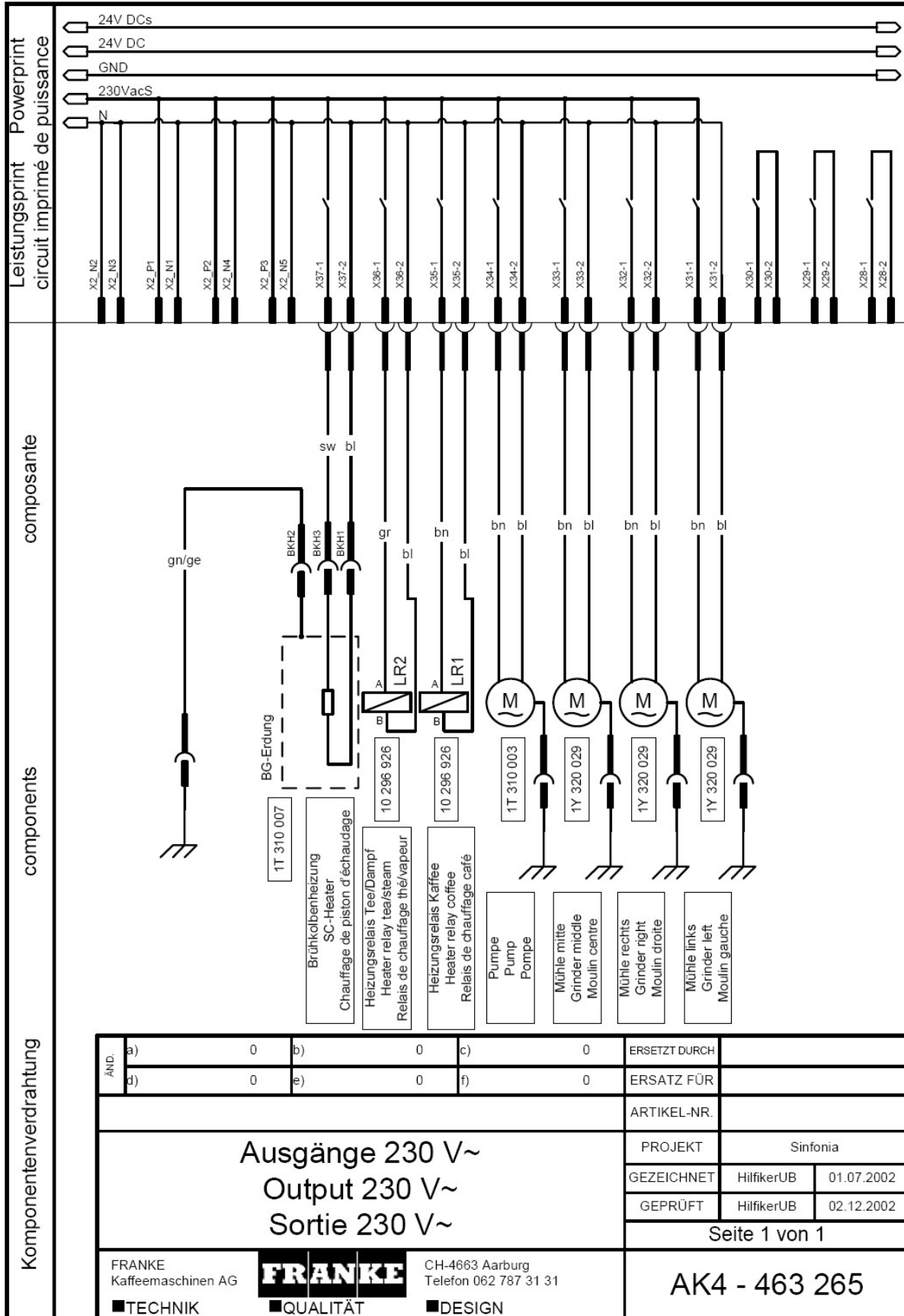

MUT Electrical Components

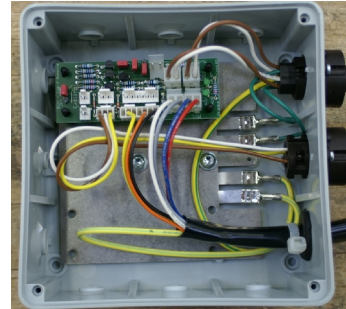
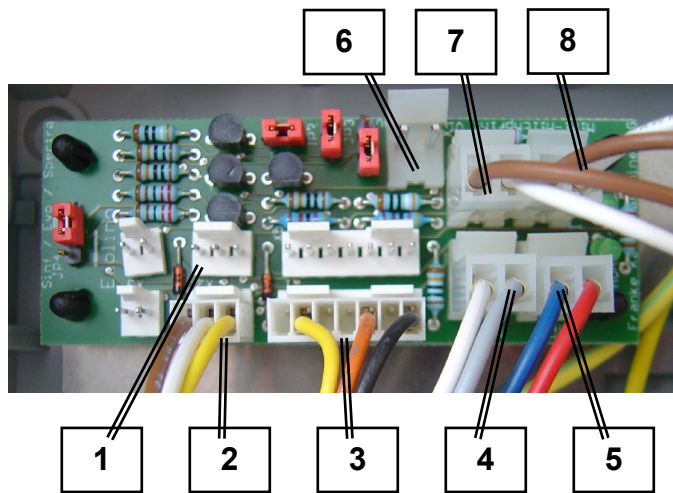

1. Level Sensor 2 (not used)
2. Level Sensor 1 connection from MUT
3. Level Sensor connection from Sinfonia
4. Milk pump 2 connection from Sinfonia

5. Milk pump 1 connection from Sinfonia
6. 24VDC Test Points
7. Milk pump 2 connection to MUT
8. Milk pump 1 connection to MUT

Milk Print Schematics

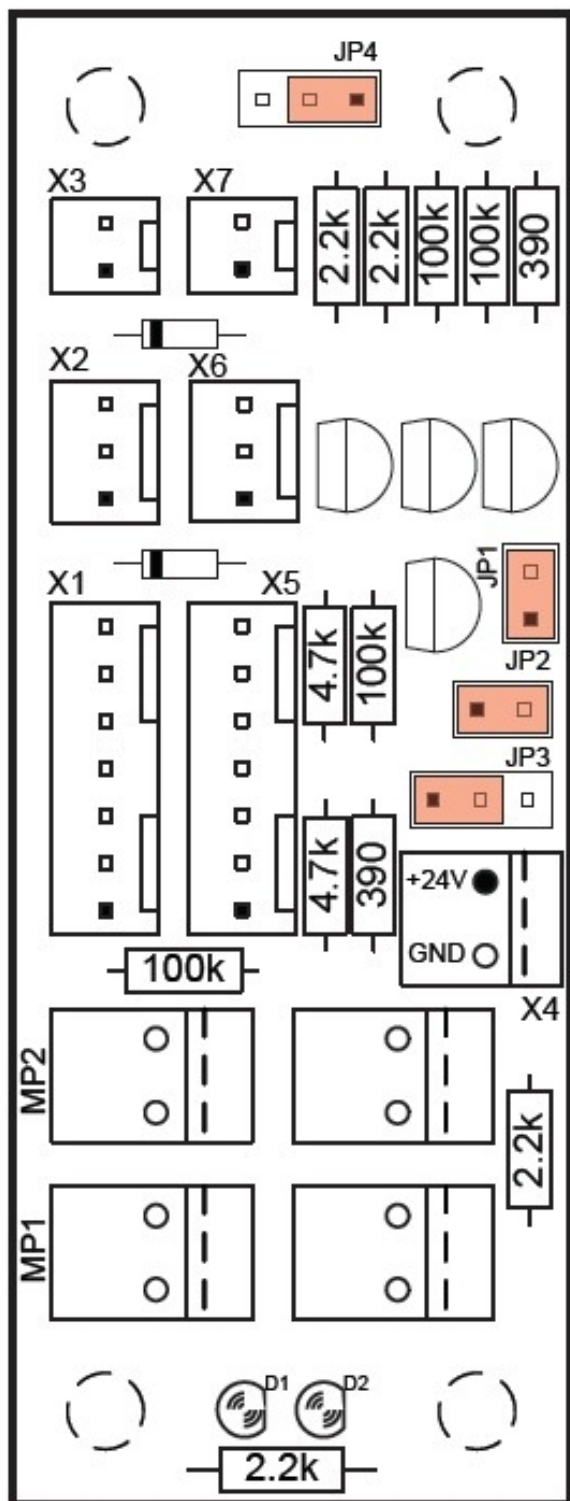

Jumper 4 (JP4)

Set the jumper according to the machine type.

Sinfonia / Evolution / Spectra



Ecolino



MUT Milk pumps

When setting the MP1 and MP2 plugs, it is important that MP1 activates milk pump 1 in the MUT box and MP2 activates milk pump 2 in the MUT box.

You can switch the brown/white connectors to correct any errors in the wiring of the MUT milk pumps.

See following page for correct wiring information.

Connector	Pin Number	Wire Color	Description / Function
X1	1	Black	+24VDC
	2		
	3	Orange	Ground
	4		
	5		
	6	Yellow	Signal Level Sensor to Coffee Machine
	7		
X2	1	Yellow	Ground
	2	White	Signal Level Sensor
	3	Brown	+5VDC
X3 (not used)	1		Reserve Optical Indicator
	2		Reserve
X4	1		Reserve +24VDC
	2		Ground
X5 (not used)	1		Reserve 2 nd Coffee Machine
	2		
	3		
	4		
	5		
	6		
	7		
X6 (not used)	1		Reserve 2 nd Coffee Machine Level Sensor
	2		
	3		
X7 (not used)	1		Reserve Optical Indicator
	2		Reserve
MP1 (Lower pump)	1	Red	+24V PWM Signal (AC signal)
	2	Blue	+24V PWM Signal (AC signal)
MP2 (Upper pump)	1	White	+24V PWM Signal (AC signal)
	2	Grey	+24V PWM Signal (AC signal)

Franke Sinfonia FSA

Technical Training Manual

Certificates and Check Lists – Chapter 9



Franke Coffee Systems
800 Aviation Parkway
Smyrna, TN 37167
(615) 462-4000

Change log

Date	Changes	Author	Change No.	ID
2009-07-20	New Manual Concept	MPH		
2010-03-01	Update Table of Contents (cleaning instructions)	MPH		A

Publisher:

Franke Kaffeemaschinen AG
 P.O. Box 235
 CH-4663 Aarburg
 Switzerland

www.franke-cs.com

Table of Contents

Change log	2
Table of Contents	3
Certificate of Conformity	5
Check Lists	9



Certificate of Conformity

Franke Kaffeemaschinen AG
CH-4663 Aarburg
Schweiz

Tel. ++41 (0)62 787 31 31
Fax ++41 (0)62 787 30 10
Internet www.franke-cs.com



EU/UE KONFORMITÄTSERKLÄRUNG DECLARATION OF CONFORMITY DÉCLARATION DE CONFORMITÉ

Wir
We **Franke Kaffeemaschinen AG**
Nous

(Name des Anbieters) (supplier's name) (nom du fournisseur)

CH - 4663 Aarburg

(Anschrift) (address) (adresse)

erklären in alleiniger Verantwortung, dass das Produkt
declare under our sole responsibility that the product
déclarons sous notre seule responsabilité que le produit

Gewerblicher Kaffeezubereiter
Industrial Coffee Percolator M « Sinfonia »
Cafetière industrielle

M 1M, M 1MH, M 1MHD, M 1MHCF1, M 1MHCF2, M 1MHCF, M 1MHDCF1, M 1MHDCF2, M 1MHDCF
M 2M, M 2MH, M 2MHD, M 2MHCF1, M 2MHCF2, M 2MHCF, M 2MHDCF1, M 2MHDCF2, M 2MHDCF
M 3M, M 3MH, M 3MHD, M 3MHCF1, M 3MHCF2, M 3MHCF, M 3MHDCF1, M 3MHDCF2, M 3MHDCF

(Bezeichnung Typ oder Modell, Los-, Chargen- oder Seriennummer, möglichst Herkunft und Stückzahl)
(name, type or model, lot, batch or serial number, possibly sources and numbers of items)
(nom, type ou modèle, no de lot, d'échantillon ou de série, éventuellement sources et nombre d'exemplaires)

auf das sich diese Erklärung bezieht, mit der / den folgenden Norm(en) oder normativen Dokument(en)
übereinstimmt.
to which this declaration relates is in conformity with the following standard(s) or other normative
document(s).
auquel se réfère cette déclaration est conforme à la (aux) norme(s) ou autre(s) document(s) normatif(s).

Sample of product tested to be in conformity with IEC:
60335-1(ed.4), 60335-2-15(ed.5), 60335-2-64(ed.3), 60335-2-75(ed.2)

Additional standards tested:
Safety: EN 60335-1:02+A1:04+A11:04, EN 60335-2-15:02, EN 60335-2-24:03+A11:04, EN 60335-2-75:04
EMC: CISPR 14-1:00+A1:01+A2:02, CISPR 14-2:01, IEC 61000-3-2:01+A2:04, IEC 60100-3-3:94+A1:01
EN 50366:03, EN 55014-1:00+A1:01+A2:02, EN55014-2:97+A1:01, EN 61000-3-2:00+A2:05,
EN 61000-3-3:95+A1:01
SVGW: W/TPW 113, 126, EN60335

(Titel und/oder Nummer sowie Ausgabedatum der Norm(en) oder der anderen normativen Dokumente)
(title and/or number and date of issue of the standard(s) or other normative document(s))
(titre et/ou no et date de publication de la (des) norme(s) ou autre(s) document(s) normatif(s))

Gemäss den Bestimmungen der Richtlinie(n); following the provisions of Directive(s);
conformément aux dispositions de(s) Directive(s)
(falls zutreffend) (if applicable) (le cas échéant)

97 / 73 / 23 / EWG + 89 / 336 / EWG + 93 / 68 / EWG

Aarburg, 18. August 2006

(Ort und Datum der Ausstellung)
(Place and date of issue)
(Lieu et date)

Geschäftsführung

M. Gyger

(Name und Unterschrift oder gleichwertige Kennzeichnung des Befugten)
(name and signature or equivalent marking of authorized person)
(nom et signature du signataire autorisé)

Leiter Forschung & Entwicklung

P. Stirnimann



Cleaning Instructions

Insert the following documents here:

- Daily Cleaning Instructions McD FSA
 - 1Y320786 – English
 - 1Y320794 – Spanish



1

McDonald's Sinfonia daily cleaning instructions

Preparation

ACCESSORIES REQUIRED:

- 3-COMPARTMENT CLEANING CONTAINER
- FRANKE MILK CLEANER
- FRANKE CLEANING TABLETS
- ANGLED BRUSH + BRUSH SET
- MCD SANITIZER SOAKED TOWEL
- 185 F DEGREE HOT WATER FOR SANITIZING PYROMETER

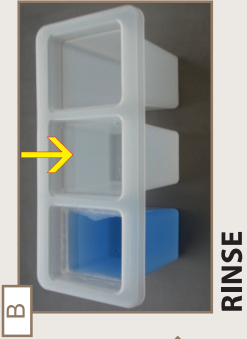

WASH

Ensure a clean 3 compartment cleaning container. Fill the 3 compartments on the cleaning container as follows:

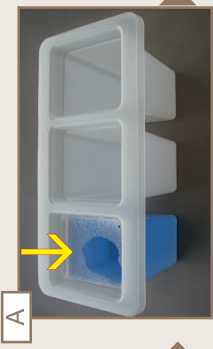

RINSE

WASH

110F - 120F



Ensure the water is 110-degrees F - 120-degrees F using the pyrometer.

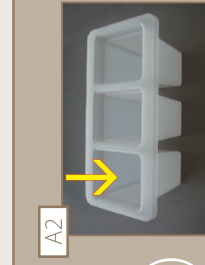

Fill the wash compartment with 110-degrees F - 120-degrees F water.



Fill the measuring bulb with milk cleaner **twice** (1oz per bulb fill), ensuring a total amount of **2oz** (60ml) milk cleaner being poured into the water in the wash compartment of the 3 compartment cleaning container as shown in the picture.

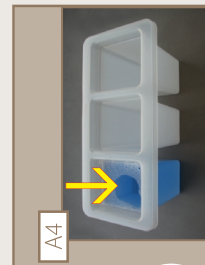

RINSE

Fill the rinse compartment (in the middle) to the fill line with fresh, cold water.

01



Press and hold the clean button for 5 seconds.

Cleaning

The display reads **CLEANING**, the machine beeps. Release the clean button.



The display reads **CLEAN THE BEAN HOPPERS**.

02



Close the hopper slide.

03



Pull the knob to release the hopper from the machine.

2

McDonald's Sinfonia daily cleaning instructions



Lift the hopper up and remove from machine.



Empty beans from hopper and remove the insert.



Wash, rinse and sanitize the hoppers, inserts and lids in the 3-compartment sink. Do not put in the ware washer.



Allow to air dry while continuing to clean. Press CLEAN to continue.



The display reads **EMPTY THE GROUNDS CONTAINER**.



Open the left-hand door and remove the grounds container.



Wipe out any grounds left in the container housing by using the angled brush and a sanitizer soaked towel.



Clean out the grounds container of all coffee grounds. Wash, rinse and sanitize in 3-compartment sink. Reinsert into the machine. Close the door. Do not put in the ware washer.



The display reads **INSERT TABLET**.

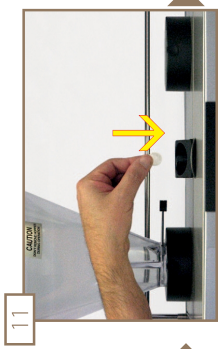

Open the cleaning tablet chute. Lightly drop 1 cleaning tablet. Close the cleaning tablet chute.



Press the Clean button.



The display reads **FILL CLEANER**.

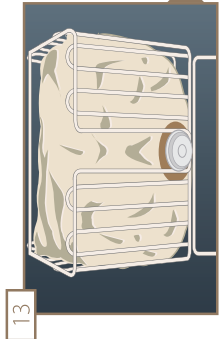

Open refrigerator door. Remove tubes from bulk milk bags and place on clean, sanitizer-soaked towel. Transfer milk bags and racks to walk-in refrigerator.

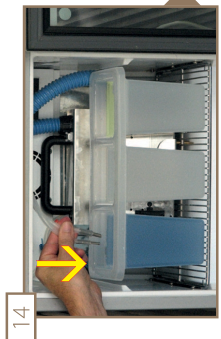

Place the prepared 3-compartment cleaning container in the refrigerator. Place the milk pick-up tubes in the wash compartment.



Press Clean. The wash cycle will start and run for 9 minutes.

Please Rinse

The display reads PLEASE RINSE. The wash cycle is completed.

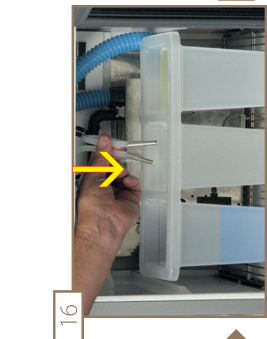

16 Move the milk pick-up tubes from the wash compartment to the rinse compartment.



17 Press the Clean button. The rinse cycle will start and run for 2 minutes.

Fill 185F Water

The display reads FILL 185F WATER. The rinse cycle is completed.

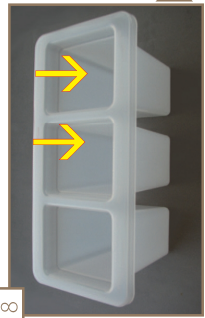

18

Brew a pot of fresh hot water. Fill the rinse compartment and the sanitize compartment with at least 185 F hot water. Ensure the water is 185 F using the pyrometer.

CAUTION

Danger of scalding! The water is hot. Handle with caution!



19 Immediately place one pick up tube in the rinse compartment and one in the sanitize compartment.

CAUTION

Danger of scalding! From hot steam. Handle with caution.

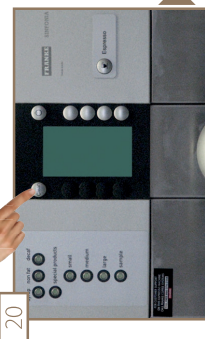

20 Press the Clean button. The sanitize cycle will start and run for 50 seconds per pump to ensure sanitation.

Clean Outlet

The display reads CLEAN OUTLET.



21

Remove the coffee outlet by pressing both thumbs against the outlet and gently pulling toward you.

CAUTION

Danger of scalding! The foamer head could be hot. Handle with caution.



22

Remove the foamer by placing your index finger behind the foamer outlet and firmly pulling towards you.

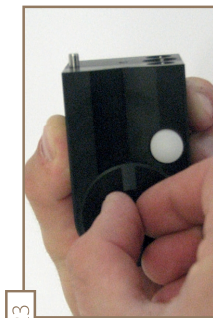

23

Remove the foamer cap by firmly twisting the cap in either direction and pulling up.



24

Remove the white check valve by prying upwards with the ring of the brush set.

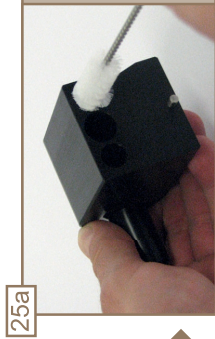

25a

Brush out the air hole.



25b

Brush out the steam hole.



25c

Brush out the milk inlet hole.



25d

Brush out the foamer outlet.



25e

Brush out the "Venturi" hole.

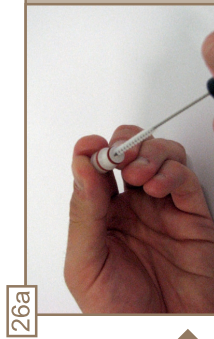

26a

Clean the bottom area of the white check valve with the smallest brush.



26b

Clean the air port on the side.

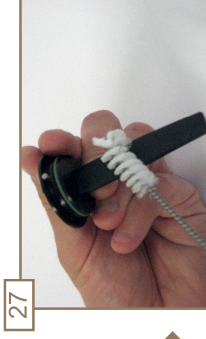

27

Clean the foamer cap.



28

Rinse all of the foamer parts in the rinse compartment of the 3-compartment-sink. Do not put in the ware washer.



29

Sanitize all of the foamer parts in the sanitize compartment of the 3-compartment-sink for 1 minute. Do not put in the ware washer.

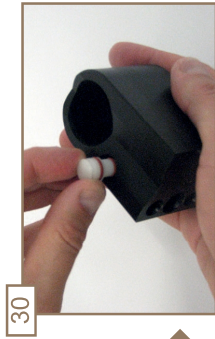

30

Reinsert the white check valve.

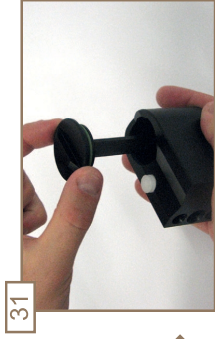

31

Reinsert the foamer cap.



32

Reinstall the foamer.



33

Reinstall the foamer outlet.

CAUTION

Danger of scalding!

The system is rinsing and steaming after attaching the outlet.

Wait until the display reads clean surface.

5

McDonald's Sinfonia daily cleaning instructions



The display reads **CLEAN SURFACE**.
Remove the drip grid, wash, rinse and sanitize it in the three compartment sink.



Clean the drip tray with a brush.

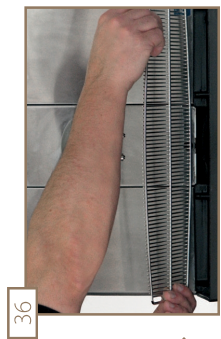

Reinstall the drip grid.



Wipe down the machine with a sanitizer soaked towel.



Make sure the hopper is absolutely dry. Use a clean paper towel to remove any residual moisture.

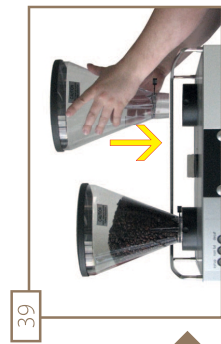

Reinstall the hopper.



Put the insert in the bean hopper.



Remove and empty the cleaning container.
Press the Clean button.



The display reads **WHAT TO DO NEXT?**

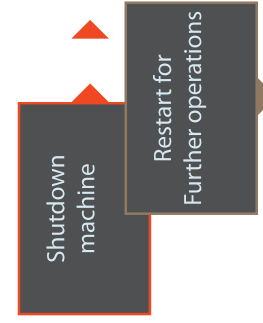

The machine is shutting down.



The machine is rebooting.

The display reads **PLEASE SELECT**.

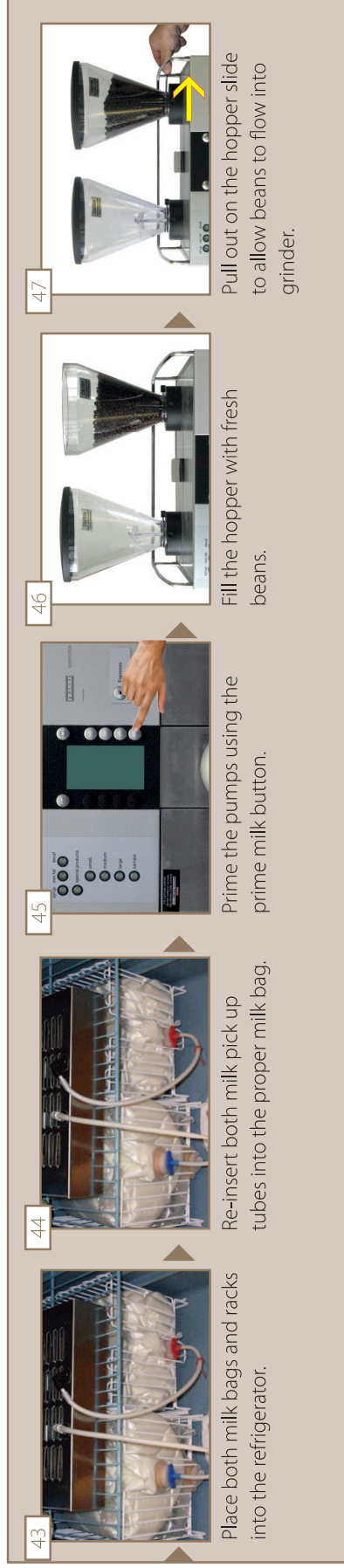

Important Safeguards

⚠ CAUTION

Risk of injury, eye injury and damage to the machine!

Objects in the coffee bean hopper or grinder may splinter and be ejected, leading to damage to the machine or injury.

- You must **only use whole beans to refill the hoppers.**
- **Never put foreign objects into the hoppers.**
- **Never poke any object around in the coffee bean hopper or grinder.**

⚠ CAUTION

Risk of injury!

Reaching into the machine may result in abrasions or crushing injuries from interior components.

- **Only open the machine when daily work requires it as directed in these instructions.** (e.g. to empty the grounds container).
- **Be careful when working on the machine when it is open.**
- **Only certified service personnel should open the machine for any other reasons.**

⚠ CAUTION

Risk of burns!

The coffee outlet and milk dispenser, hot water outlet and steam wand may be extremely hot.

- **Do not touch the dispensers or outlets.**

⚠ CAUTION

Danger of scalding!

During heat-up, normal operation and cleaning hot fluids and steam are dispensed.

- **Keep hands away from the dispensers and outlets during operation.**
- When preparing drinks, the products themselves pose a risk of scalding.
- **Always handle hot drinks properly.**

Preparación

ACCESORIOS NECESARIOS:

RECIPIENTE DE LIMPIEZA CON 3 COMPARTIMENTOS
LÍQUIDO LIMPIADOR DE LECHE FRANKIE
COMPRESIDOS DE LIMPIEZA FRANKIE
CEPILLO ANGULADO + JUEGO DE CEPILLOS
PAÑO IMPREGNADO CON DESINFECTANTE MCD
AGUA A 185F PARA ESTERILIZAR
PIRÓMETRO

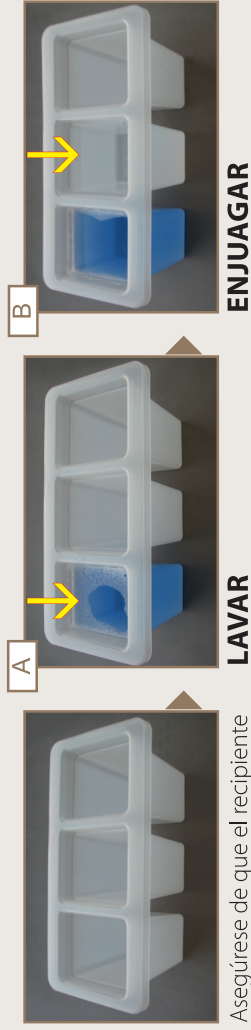

LAVAR

Asegúrese de que el recipiente para limpieza de 3 compartimentos está limpio. Rellene los 3 compartimentos del recipiente de la siguiente manera:

LAVAR

A1 **110F - 120F**



Asegúrese de que el agua está entre 110 y 120 F utilizando el pirómetro.

A2

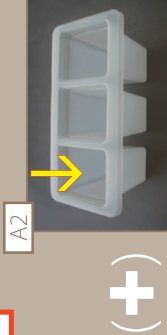

Rellene el compartimento de lavado con agua entre 110 y 120 F.

A3



Rellene el bulbo medidor con líquido limpiador de leche **dos veces** (1 onza [30 ml] por bulbo), de manera que haya un total de **2 onzas** (60 ml) de líquido limpiador de leche en el agua del recipiente de limpieza con 3 compartimentos tal y como muestra la imagen.

A4

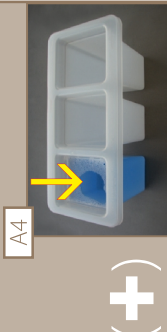

ENJUAGAR

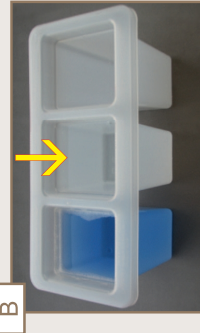

Rellene con agua fría y limpia el compartimento de aclarado (en el centro) hasta la línea de llenado.



01

Presionar el botón de limpieza y mantener durante 5 segundos.



En la pantalla aparece LIMPIEZA, la máquina emite un pitido. Suelte el botón de limpieza.



En la pantalla aparece LIMPIAR TOLVAS.



02

Cierre la tapa de la tolva.



03

Tire del botón para extraer la tolva de la máquina.



Levante la tolva para extraerla de la máquina.



Vacíe los granos de la tolva y retire el inserto.



Lave, aclare y desinfecte las tolvas, insertos y tapas en el recipiente de 3 compartimentos. No colocar en el lavaobjetos.



Dejar que se seque para continuar con la limpieza. Presione LIMPIAR para continuar.



En la pantalla aparece **VACIAR CONT. POSOS**.



Abra la puerta a la izquierda y extraiga el recipiente para posos.

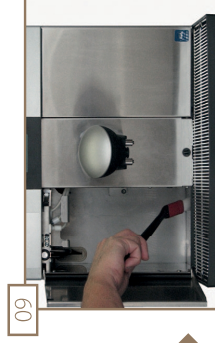

Utilice el cepillo angulado y el paño impregnado con desinfectante para limpiar los restos de posos que queden en el recipiente.



Retirar todos los granos que se encuentren en el recipiente para granos de café. Lavar, enjuagar y desinfectar en el recipiente de 3 compartimentos. Volver a colocar en la máquina. Cerrar la puerta. No colocar en el lavaobjetos.



En la pantalla aparece **INSERTAR PASTILLA**.

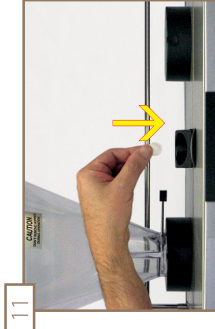

Abra la tolva de comprimidos para limpieza. Introducir con suavidad 1 comprimido de limpieza. Cerrar la tolva de comprimidos para limpieza.



Presionar el botón de Limpieza.



En la pantalla aparece **RELLEN DETERGENTE**.

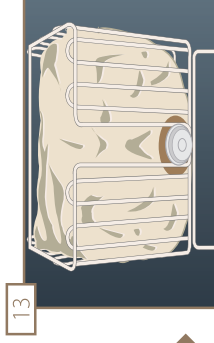

Abra la puerta del refrigerador. Retirar los tubos de los depósitos de leche a granel y colocarlos en un paño empapado en agente esterilizador. Trasladar los depósitos de leche y las rejillas en el frigorífico grande.

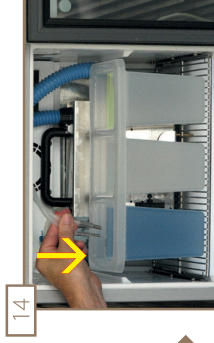

Colocar el recipiente de 3 compartimentos para limpieza ya preparado en el frigorífico.

Colocar los tubos de absorción de leche en el compartimento de lavado.



Presione Limpieza.

Comenzará el ciclo de limpieza que dura 9 minutos.

por favor enjuagar

En la pantalla aparece ENJUAGAR. El ciclo de lavado ha finalizado.

PRECAUCIÓN
¡Peligro de escaldaduras!
El agua está caliente.
¡Proceda con precaución!

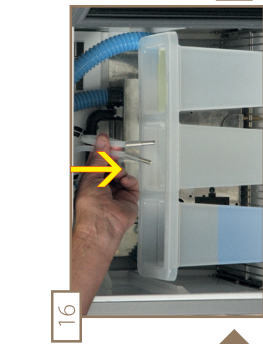

16

Cambie los tubos de absorción de leche del compartimento de lavado al de aclarado.



19

Coloque inmediatamente un tubo aspirador en el compartimento de aclarado y otro en el compartimento de esterilización.



17

Presionar el botón de Limpieza. Comenzará el ciclo de aclarado que dura 2 minutos.



20

Presionar el botón de Limpieza. Comenzará el ciclo de esterilización que dura 50 segundos por bomba para asegurar la completa desinfección.

Rellenar con agua a 185F

En la pantalla aparece RELLENAR CON AGUA A 185FC. El ciclo de aclarado ha finalizado.

PRECAUCIÓN
¡Peligro de escaldaduras!
Por vapor caliente.
Proceda con precaución.

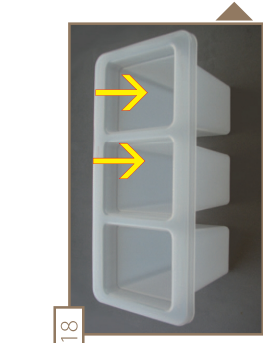

18

Prepare un recipiente con agua caliente limpia. **Rellene el compartimento de aclarado y el de desinfección con agua al menos a 185F.** Asegúrese de que el agua está a una temperatura de 185F utilizando el pirómetro.

Limpier salida

En la pantalla aparece LIMPIAR SALIDA.



21

Retire la salida para café presionando con los dos pulgares contra la salida y tirando con suavidad hacia usted.

PRECAUCIÓN
¡Peligro de escaldaduras!
El espumador podría estar caliente.
Proceda con precaución.



22

Retire el espumador colocando su dedo índice tras la salida de espuma y tirando con firmeza hacia usted.

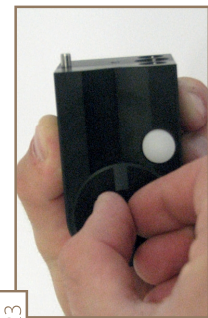

23

Retire la tapa del espumador girándola en varias direcciones y estirando.



24

Retire la válvula de retención blanca levantándola hacia arriba con el anillo del juego de cepillos.

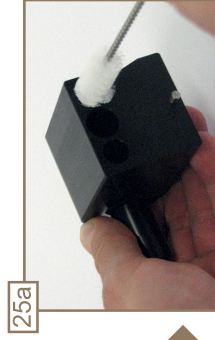

Cepille la salida de aire.

25b



Cepille la salida de vapor.

25c



Cepille la boca de entrada de leche.

25d



Cepille la salida del espumador.

25e



Cepille la salida de "Venturi".

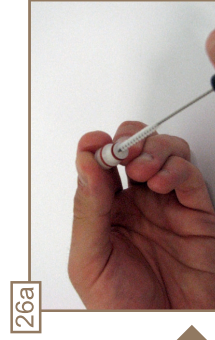

Limpe la base de la válvula de retención blanca con el cepillo más pequeño.

26b



Limpe el puerto de entrada de aire en el lateral.

27



Limpe la tapa del espumador.

28



Enjuagar todas las partes del espumador en el compartimento de aclarado del recipiente para limpieza. No colocar en el lavaobjetos.

29



Esterilice todas las partes del espumador en el compartimento para desinfección del recipiente para limpieza durante 1 minuto. No colocar en el lavaobjetos.

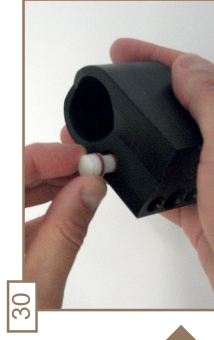

Inserte de nuevo la válvula de retención blanca.

31



Inserte de nuevo la tapa del espumador.

32



Coloque el espumador.

33



Coloque la salida del espumador.

⚠ PRECAUCIÓN

¡Peligro de escaldaduras!
El sistema se aclara y echa vapor tras ajustar la salida. Esperar hasta que en la pantalla aparezca limpiar superficie.



En la pantalla aparece **LIMPIAR SUPERFICIE**. Retirar la rejilla de goteo, lavarla, enjuagarla y desinfectarla en el recipiente de tres compartimentos.



Limpiar la bandeja de goteo con un cepillo.

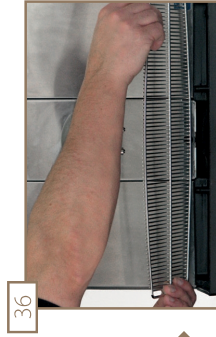

Vuelva a colocar la rejilla de goteo.



Pasar un paño impregnado con desinfectante por la máquina.



Asegurarse de que la tolva está completamente seca. Utilizar una toalla de papel para retirar la humedad residual.



Vuelva a colocar la tolva.



Coloque el inserto en la tolva para granos.



Retirar y vaciar el contenedor de limpieza. Presionar el botón de Limpieza.



En la pantalla aparece **¿QUÉ HACER AHORA?**



La máquina se apaga.

42



La máquina se reinicia.



seleccione

En la pantalla aparece **SELECCIONAR**.

<p>43</p> 	<p>Colocar los dos depósitos de leche y las rejillas en el frigorífico.</p>
<p>44</p> 	<p>Volver a colocar los tubos de absorción de leche en el depósito de leche apropiado.</p>
<p>45</p> 	<p>Prepare las bombas utilizando el botón de preparación de leche.</p>
<p>46</p> 	<p>Rellene la tolva con granos frescos.</p>
<p>47</p> 	<p>Tire de la tapa de la tolva para permitir que los granos entren en el molinillo.</p>

Medidas preventivas importantes

⚠ PRECAUCIÓN

Riesgo de sufrir lesiones, lesiones oculares o daños en la máquina.

- Los objetos presentes en la tolva para granos o en el molinillo pueden astillarse y salir expulsados, pudiendo causar lesiones o daños en la máquina.
- Utilizar solo granos enteros para rellenar la tolva.
 - Nunca ponga objetos extraños en las tolvas.
 - No acerque ningún objeto a la tolva para granos o al molinillo.

⚠ PRECAUCIÓN

Peligro de lesión

El contacto con componentes interiores de la máquina puede causar quemaduras o daños en los componentes.

- Abrir la máquina solo cuando el trabajo diario así lo requiera tal y como se indica en estas instrucciones. (p.ej. vaciar el recipiente para posos).
- Tenga cuidado al trabajar con la máquina cuando esté abierta.
- Solamente el personal del servicio autorizado será el responsable de abrir la máquina por otras razones.

⚠ PRECAUCIÓN

¡Peligro de quemaduras!

La salida de café y el dispensador de leche, la salida de agua caliente y el lateral por donde sale el vapor pueden estar extremadamente calientes.

- No tocar los dispensadores o las salidas.

⚠ PRECAUCIÓN

¡Peligro de escaldaduras!

Mientras la máquina se calienta, ésta opera normalmente y expende líquidos y vapor para limpieza calientes.

- No acerque sus manos a los dispensadores y salidas durante el funcionamiento.
- Cuando prepare bebidas, deberá tener cuidado ya que éstas suponen riesgo de escaldaduras.
- Tenga siempre especial cuidado con las bebidas calientes.

Check Lists

Insert the following documents here:

- Hook-Up Guide check list
- CSS User Guide



Specialty Coffee Machine Franke Sinfonia



Install / Hook-up Guide



Imported exclusively for
McDonald's®

By

Franke Coffee Systems Americas
800 Aviation Parkway
Smyrna, TN 37167
USA Toll Free: 800.537.2653

www.franke.com

Publisher:

Franke Kaffeemaschinen AG
P.O. Box 235
CH-4663 Aarburg
Switzerland

Internet www.franke.com

Document version March 2011. Information is subject to change.

Reproduction of this document, including excerpts, no matter in what form, is prohibited without prior written permission of the publisher.

Images and information in this manual are subject to change to reflect technical improvements if they become necessary.

Table of contents

1	Explanation of symbols.....	4
2	Area of application.....	4
2.1	Service technicians.....	4
2.2	Questions or problems	4
3	For your safety	5
4	Packing list.....	6
4.1	Packing list overview	6
5	Installation	7
6	Schematics	15
7	McDonald's Hook Up Check List.....	18

1 Explanation of symbols

The symbol illustrated to make you aware of a hazard and warning.



Danger indicates potentially life-threatening danger or grave injury.



Warning indicates risk of injury.



Caution indicates risk of minor injury.



Notice indicates possibility of damage to the machine.



This symbol indicates tips, shortcuts and additional information.

2 Area of application

This safety information applies to the entire service technician documentation. Read and understand the present information before performing any work on the machine.

2.1 Service technicians

This documentation has been created exclusively for FRANKE service technicians and authorized partners. It will enable service technicians to perform their tasks on the coffee machine and its add-on units.

These tasks include start-up, programming, maintenance work, troubleshooting and product quality settings.

2.2 Questions or problems

If you encounter questions or problems when working on the machine, contact our Service Hotline:

Phone hotline: USA Toll Free: 800.537.2653

3 For your safety

This documentation has been created exclusively for FRANKE service technicians and authorized partners. It will enable service technicians to perform their tasks on the coffee machine and its add-on units.

These tasks include start-up, programming, maintenance work, troubleshooting and product quality settings.

WARNING

Danger of injury and damage to the machine!

Improperly making changes in the form of retrofits or repairs can lead to injury or damage to the machine.

- ◆ Do not place hands inside the machine if any body panels are removed. Electrical shock could occur.
- ◆ Be sure to read the safety information in the Service folder.
- ◆ Programming and settings may only be undertaken by authorized service technicians.
- ◆ Modifications and repairs may only be undertaken by authorized service technicians.
- ◆ Do not undertake any modifications to the machine that are not described in the documentation provided by FRANKE.

CAUTION

Health hazard from heavy lifting!

Lifting heavy objects can cause injury.

- ◆ Do not lift or move the machine alone.

NOTICE

Damage from improper transport.

Improperly transporting the machine can cause faults or damage.

- ◆ Always transport the machine in an upright position.
- ◆ Transport the machine so that it is protected from the elements, such as rain and moisture.

NOTICE

Damage from using inappropriate tools.

Using inappropriate tools may damage components of the machine and render it unusable.

- ◆ Use the tools recommended by FRANKE.
- ◆ Work within the installation guidelines recommended by FRANKE, if specified.

4 Packing list

4.1 Packing list overview



1Y 320 268	Case with foam insert
1Y 320 683	Cleaning box
1Y 320 695	Cleaning instruction
1Y 320 696	Cleaning instruction (spanish)
1Y 320 697	Foamer cleaning
1Y 320 698	Foamer cleaning (spanish)
1L 301 160	Brush
1L 301 376	Brush set for cappuccinatore compl.
1L 300 158	Stop plate for cups
02 224 402	Washer M4
02 224 002	Hex screw M4
02 221 805	Screw M4x10
BK 300 935	Cleaning tablettts 100 pcs.
BK 301 732	Detergent for milksystems
10 300 924	Adjustcard
10 300 931	Installcard
	Test report

5 Installation

DANGER

Electrocution caused by touching parts with live voltage

- ◆ Safeguard parts with live voltage against contact.

1. Ensure the power receptacle is the L6-30 type and that the power is correct 208V – 230V. **IF NOT – Notify the GC to have the problem remedied!**



fig 1.01

2. Install the leg support and the legs **1** and adjust the height by turning the lower part of the legs. The leg support for the front left can be found inside the cleaning box.

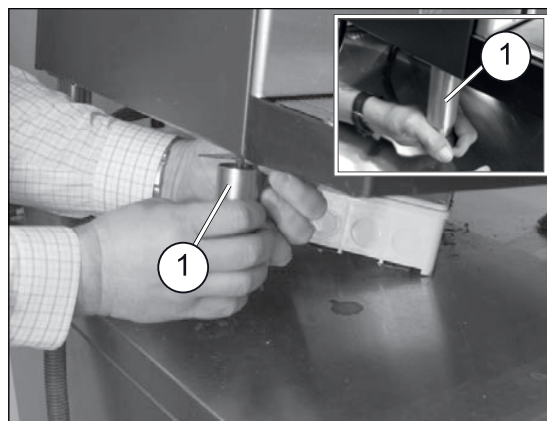

fig 1.02

3. Install quick disconnects onto the water line ❶ feeding the machine
4. Connect the water line ❶ from R/O system to the water line from the machine.

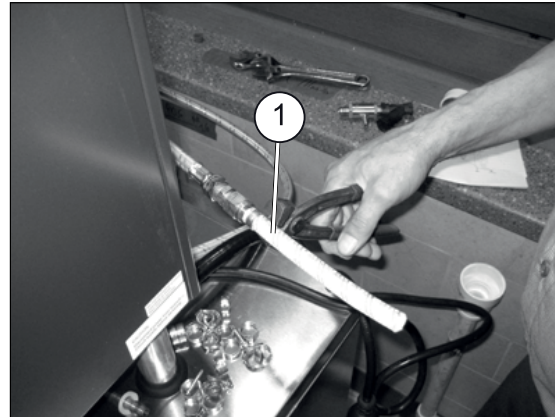

fig 1.03

5. Install the shelf supports ❸ in the fridge. Position the supports 3 notches down from top screw. **There should be enough space to allow for bag milk cages under the shelf.**

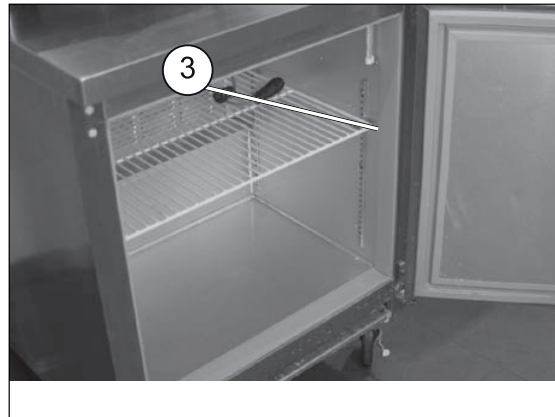

fig 1.04

6. Place the shelf ❶ in the fridge. **There should be enough space to allow for bag milk cages under the shelf.**

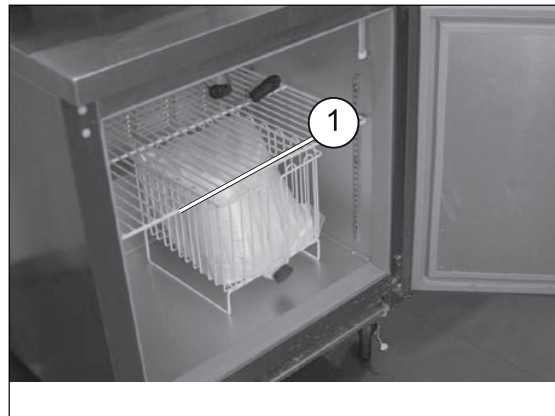

fig 1.05

7. Locate the box ❷ with the MUT unit and remove it.
8. Disconnect the 2 quick connects ❸ from the grey control box and set it aside.

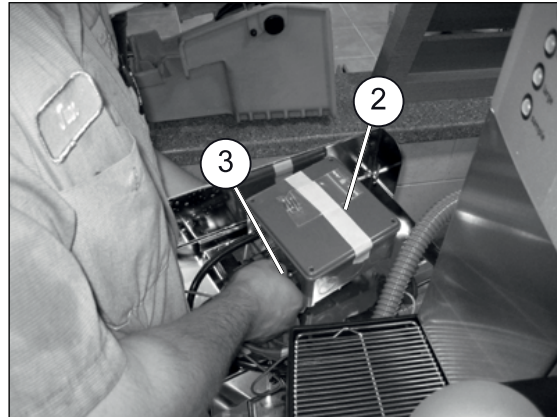

fig 1.06

9. Place the MUT on the shelf with the milk level sensors facing forward.

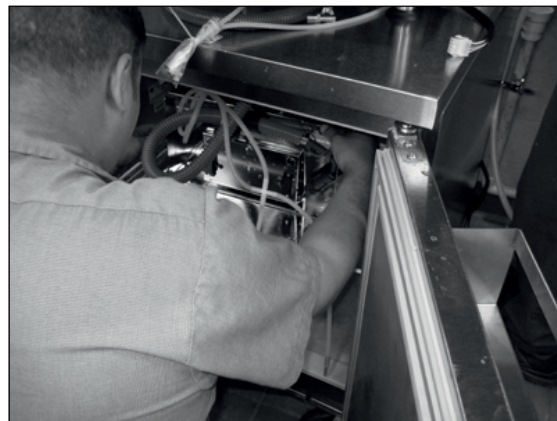

fig 1.07

NOTICE

Damage from machine

Damaging the wirings can cause faults.

- ◆ Be careful not to damage the wire insulation.

10. Route the 2 quick connects **2** through the large hole **3** in the fridge.

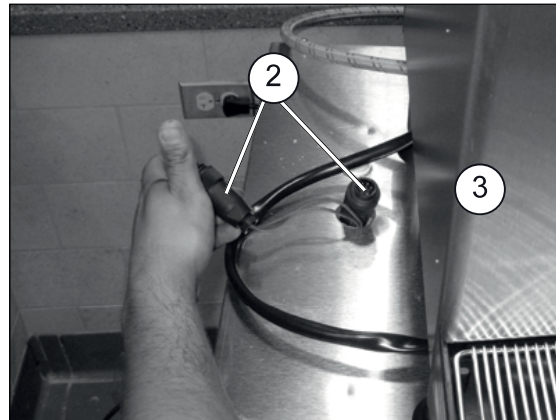

fig 1.08

11. Once both quick connects are through the hole, push the blue or black hose **1** 3-4" through the hole and place the lower grommet so it seats against the inside of the fridge.

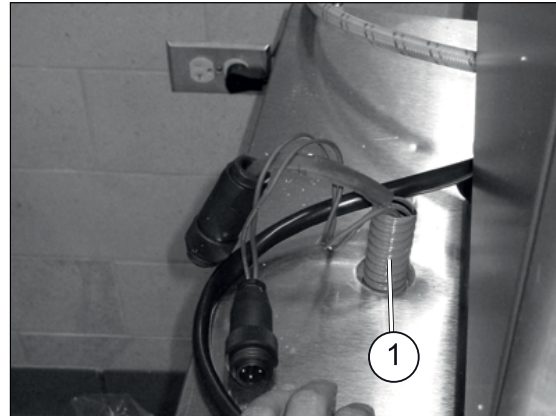

fig 1.09

12. Take the grommet **2** you removed from the blue hose and cut it down one side **3**.
13. Place the grommet **2** around the blue hose **1** and push it into the hole from the top.

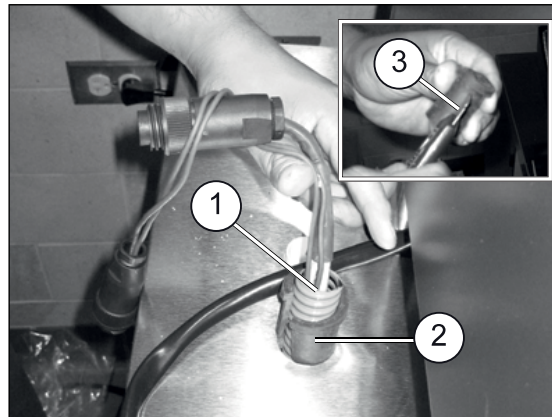

fig 1.10

14. Take the cover off the MUT control box and ensure the fittings are secure.
15. Secure the cover with the screws attached to the lid.

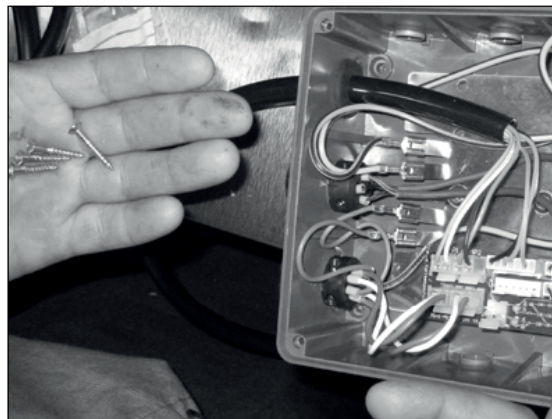

fig 1.11

16. Connect the 2 quick connects to the MUT control box AND the 8-pin connector from the machine to the control box **1**.

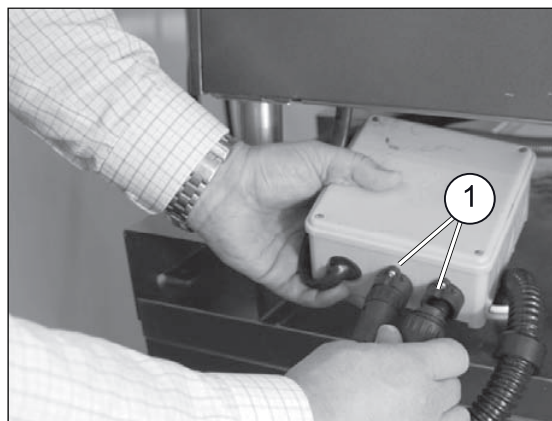

fig 1.12

17. Take the 2 tubes in the grey hose and feed them through the small hole in the fridge.
18. Feed the remainder of the grey hose through the hole ②.

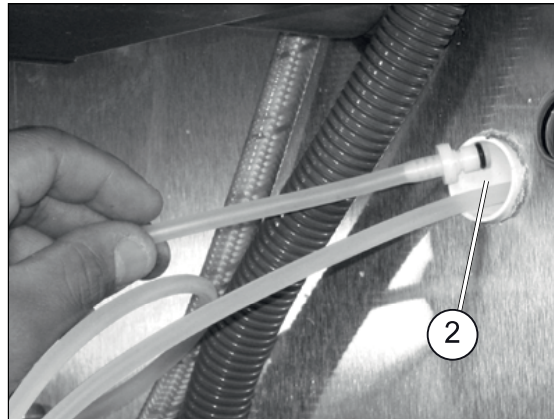

fig 1.13

19. Connect the 2 tubes from the grey hose onto the top of the MUT ①.

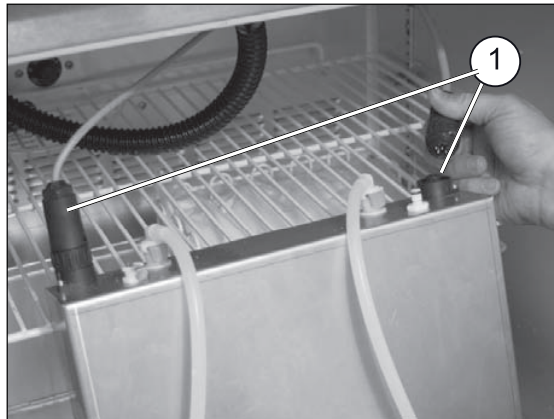

fig 1.14

20. Route the drain hose to the floor sink or drain ②. Cut to the appropriate length if necessary and zip-tie to the drain. Leave extra length for movability and ensure the drain is running downhill.

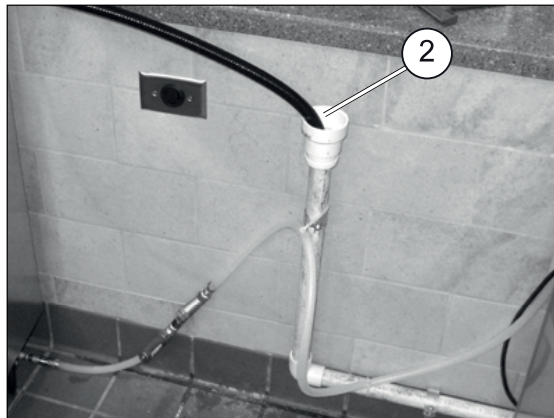

fig 1.15

21. Install the cup rail.



fig 1.16

22. Remove the protective covering from the machine.



fig 1.17

23. Install the hoppers. Decaf is on the left side.



fig 1.18

24. Install the speed rack ② on front of the fridge.
25. Install the anti-tip bracket on the top rear of the fridge.

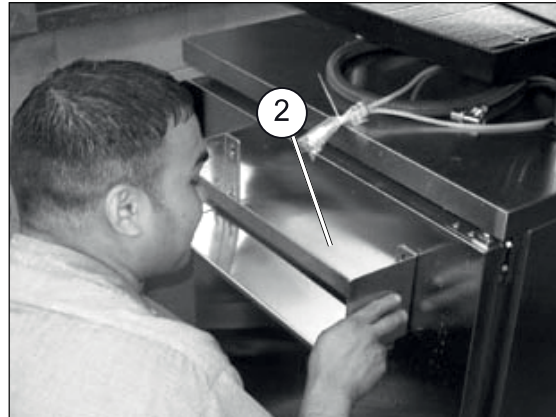
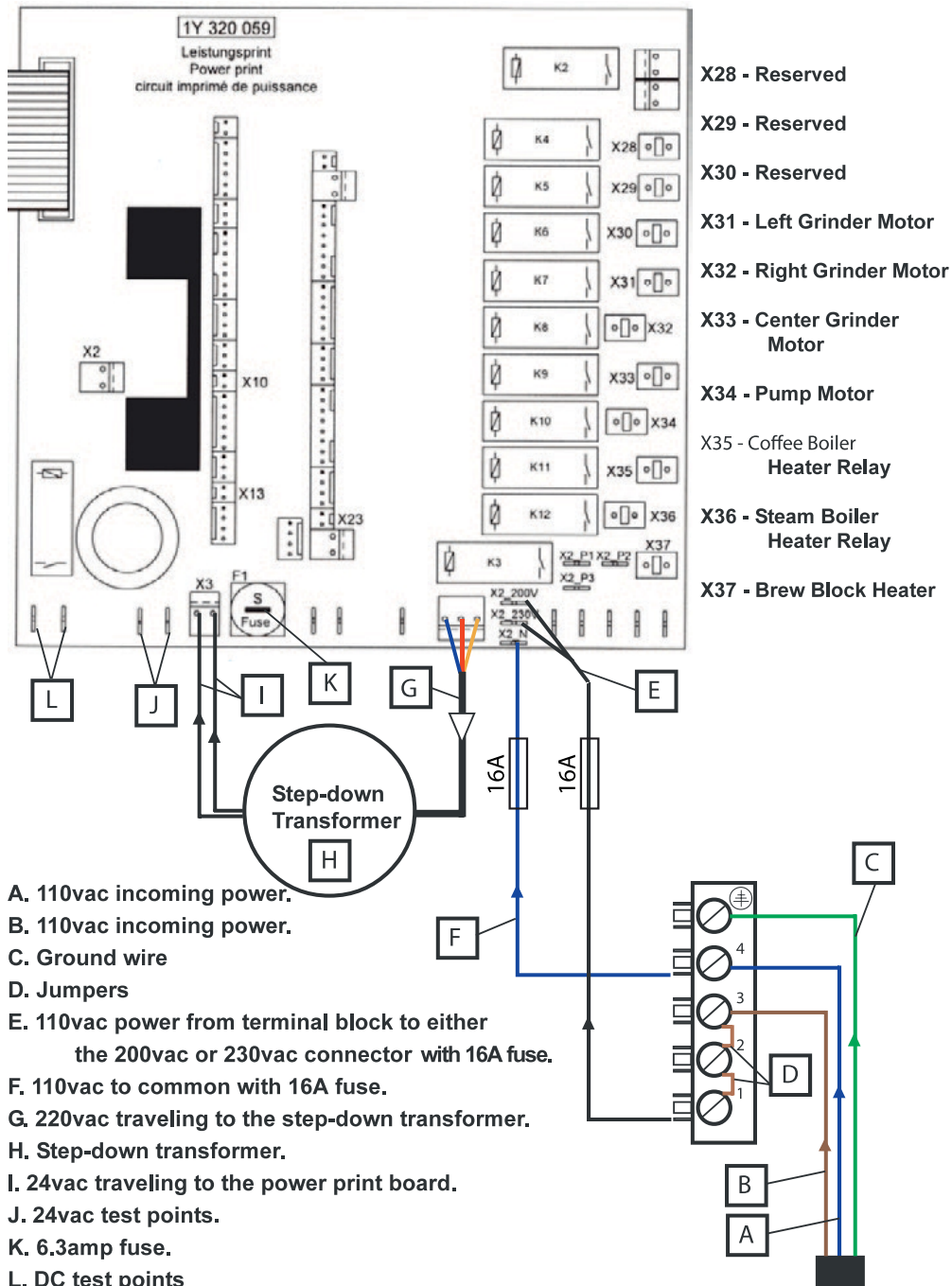
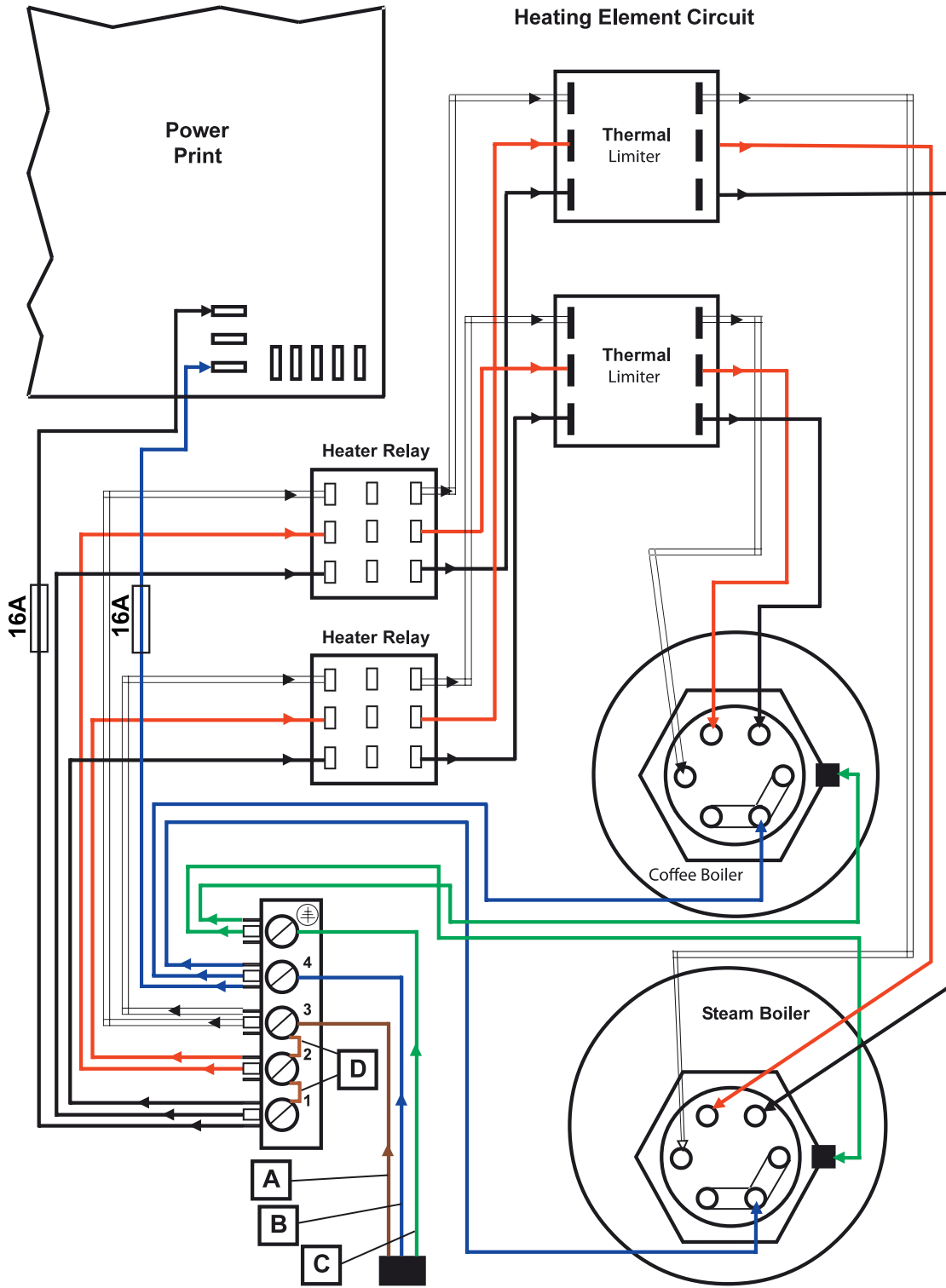

fig 1.19

6 Schematics





7 McDonald's Hook Up Check List

Please fill out completely and fax to (206) 782-4517

Serial number:		Date:	
Store number:		Installer:	

1. Ensure the power receptacle is the L6-30 type and that the power is correct, single-phase, 208V – 230V, 30amp *IF NOT – Notify the GC to have the problem remedied!

2. Have the legs been installed properly and the machine leveled? Check the cleaning box for the leg support for the front left leg. Install if needed.

3. Are the quick disconnects installed onto the water line feeding the machine? Is the water line long enough to pull the machine forward?

4. Is the water line from the coffee machine connected to the water line from R/O system?

5. Have the shelf supports been installed at 3 notchs down from top screw?

6. T here should be enough space to allow for Bag Milk Cages under the shelf

7. Has the MUT been located and placed in the fridge?

8. Is the upper grommet installed on the blue or black hose?

9. Are the 2 quick connects routed through the large hole in the fridge? Be careful to check for damaged or cut wire insulation!

10. Has the blue or black hose been pushed 3-4" through the hole and is the lower grommet seated against the inside of the fridge?

11. Is the grommet placed around the blue or black hose and pushed into the hole from the top?

12. Has a large zip tie been placed around the blue hose just above the grommet?

13. Are the 2 electrical quick disconnects to the MUT control box AND the 8-pin connector from the machine to the control box attached correctly?

14. Are the 2 tubes in the grey hose installed through the small hole in the fridge?

15. Are the 2 tubes from the grey hose connected onto the back of the MUT?

16. Has the drain hose been routed to the floor sink or drain and attached to it using zip-tie? Run water down the drain to ensure that it does NOT back up.

17. Is the cup rail installed?

18. Has the protective covering been removed from the machine?

19. Are both bean hoppers installed with Decaf on the left side?

20. Is the speed rack installed on the front of the fridge?

21. Is the anti tip bracket installed onto the back of the fridge?

Installing Technician:		Store Manager:	
Signature & Date:		Signature & Date:	



A series of horizontal lines for writing, consisting of 25 evenly spaced lines extending across the width of the page.

CSS Users Guide

The screenshot shows a web browser window displaying the Franke Coffee Systems North America website. The browser's address bar shows 'KSS'. The website has a red header with the Franke logo and three images: a coffee machine head, a technician working on a machine, and hands connecting wires. Below the header, there is a search bar with the placeholder text '<Enter search term>' and dropdown menus for '<All Types>' and '<All documents>'. The main content area is divided into two columns: 'New Info Docs and Drawings' and 'Top Links'. The 'New Info Docs and Drawings' column contains a list of documents under 'Info' and 'Drawings' categories. The 'Top Links' column contains a list of links under an 'Info' category. A left sidebar contains navigation links for Product info, After-Sales, Order, Instructions, and New documents/Top Links. At the bottom of the sidebar, there is a login section for 'Mark Weesner' and a version field.

New Info Docs and Drawings				Top Links		
> Info				> Info		
10-Service Information	Sinfonia FSA	04.05.2011	User Guide	KSS	10.11.2010	
10-Service Information	Sinfonia	04.05.2011	QRG New Coffee Outlet	Sinfonia FSA	31.03.2011	
03-Preventive Maintenance US/Canada	Sinfonia FSA	03.05.2011				
> Drawings						
Grinder	Sinfonia	28.04.2011				
Autosteam	Evolution	27.04.2011				

Table of Contents

CSS.....	1
Users Guide	1
Table of Contents.....	3
CSS Coffee Machines Service System.....	5
Starting CSS.....	5
Starting CSS on the Internet.....	5
Navigation	5
CSS Login.....	5
CSS Internet Site.....	6
CSS Overview	7
Navigating in CSS.....	7
After-Sales information	7
Online Parts Catalog	9
Drawings.....	9
Articles List	10
Instructions	11
Instructions	11
Notes.....	13

CSS Coffee Machines Service System

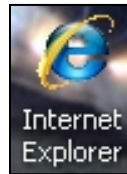

FRANKE

Coffee Machines Service System Login

Server: css.franke.ch

Username:

Password:

Confidentiality Note
The information provided in this website is confidential and intended only for the named user (identified by the personal password provided by Franke). Any unauthorized access or use, particularly making such information available to others is strictly prohibited.

✓ Starting CSS on the Internet

- Ø Start by clicking on the internet explorer icon on your desktop or in your program directory.

✓ Navigation

- Ø Navigate to the Franke Coffee Systems CSS login page.
<http://css.franke.ch>

✓ CSS Login

- Ø Enter your username and password to enter the CSS internet site.
Note: Save this page to your internet favorites for quick access at a later time.

CSS Internet Site

Directory

Search Engine

Latest Docs and Drawings

The screenshot shows the Franke CSS Internet Site interface. The left sidebar contains a menu with categories: Product info, After-Sales, Order, Instructions, New documents/Top Links, and Help. The main content area features a search bar, a table of 'New Info Docs and Drawings', and a 'Top Links' section. A red oval highlights the sidebar menu, the search bar, and the 'New Info Docs and Drawings' table. Arrows point from the labels above to these elements.

New Info Docs and Drawings			
> Info			
01-Service Information	Sinfonia FSA	04.05.2011	
10-Service Information	Sinfonia	04.05.2011	
03-Preventive Maintenance US/Canada	Sinfonia FSA	03.05.2011	
> Drawings			
Grinder	Sinfonia	28.04.2011	
Autoteam	Evolution	27.04.2011	

Top Links		
> Info		
User Guide	KSS	10.11.2011
QRG New Coffee Outlet	Sinfonia FSA	31.03.2011

Navigation in CSS

Product info
www.franke.com

After-Sales
[After-Sales information](#)
[Contact](#)

Order
[Drawings](#)
[Articles list](#)

Instructions
[Coffee machine](#)
[Options/Add on units](#)
[Vending systems](#)
[Diagnosis](#)

New documents/Top Links
[Help](#)

Login as:
 Mark Weesner
[logout](#)

Version

- √ **Product Info**
 - ∅ Takes you to the Franke Coffee Systems Homepage.
- √ **After-Sales**
 - ∅ Contains after-sales information such as software updates, special instructions and service bulletins for Franke Coffee Machines.
 - ∅ Under *contact* you can send a message to Support International. To be used in conjunction with CSS ONLY. Do not send technical questions to this contact email.
- √ **Order**
 - ∅ The purchase order page allows you to look at past and current parts orders
 - § By clicking on *drawings* or *articles list*, you can reach the online parts catalog.
- √ **Instructions**
 - ∅ This will take you to the service manuals and instruction manuals for Franke Coffee Machines.

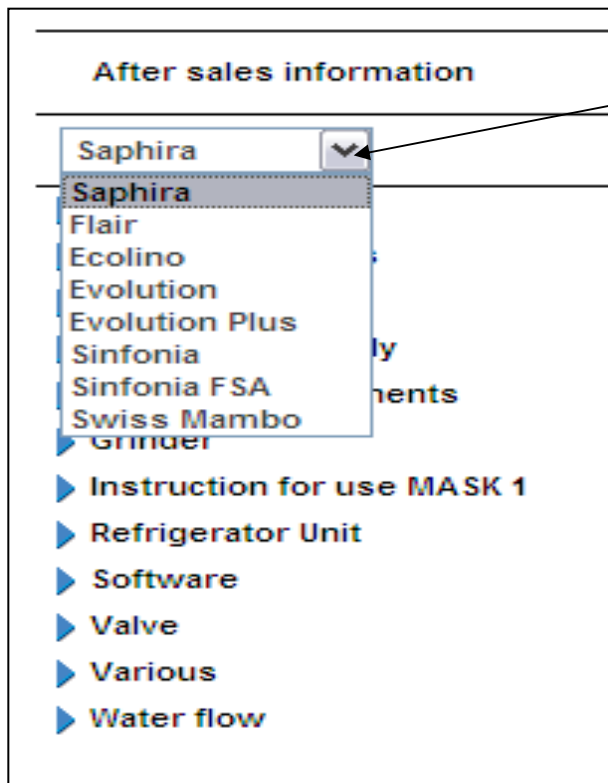

▼ **After Sales**

∅ Open the pull-down menu and select your Franke coffee machine

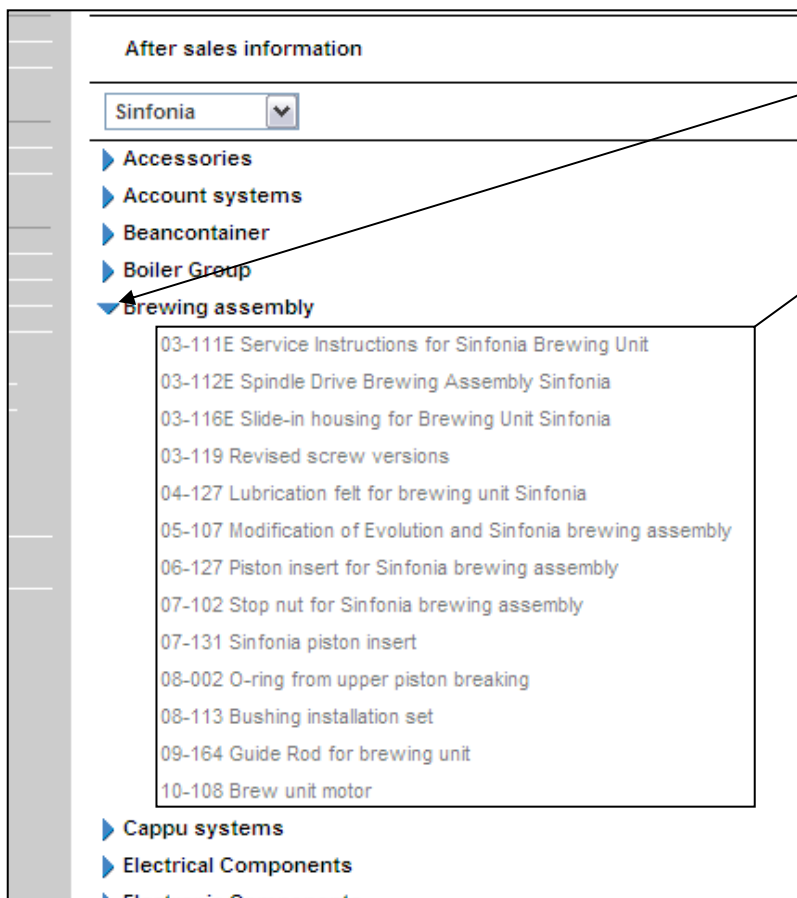

∅ Click on the triangle icon to show details.

∅ Select one of the listed Service Bulletins and click on the link to open to the "Bulletin Download Page"

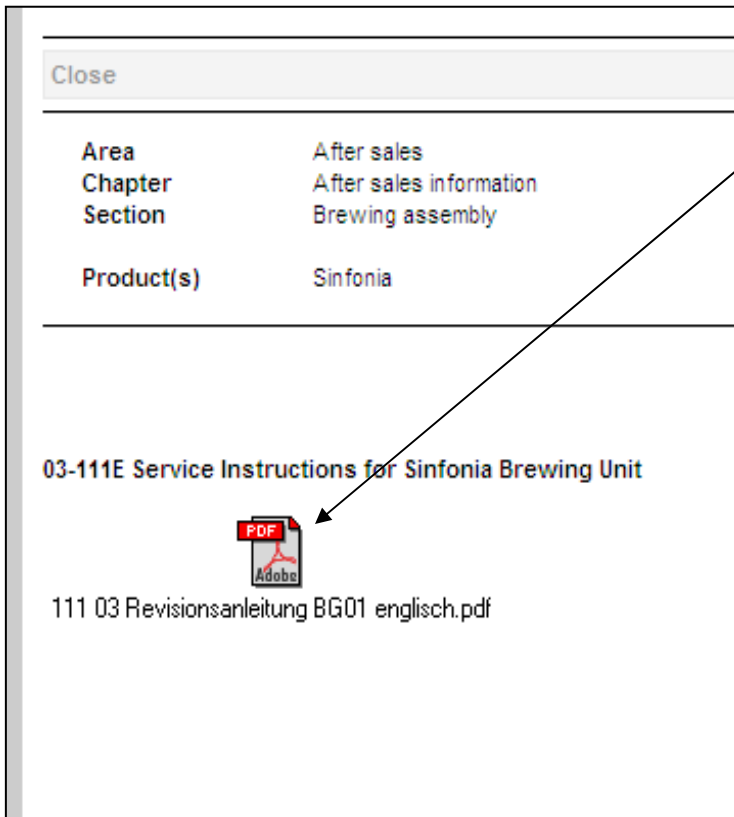

✓ After Sales (continued)

- Ø Click on the “pdf” file to open the file on your computer
- Ø Click on close to return to the previous window.





- Ø To save the file on your computer, click on the “Save file” icon.

Close

Area	After sales
Chapter	After sales information
Section	Software
Product(s)	Sinfonia

09-005 Software update Sinfonia FSA V.25.3 (This document r

 Service Information 09-005.pdf

 Sinfonia FSA Software 25.3r0.ssw

▼ **After Sales (continued)**

- Ø To download software, click on the software icon and a pop up window will prompt you to select and choose the location to save the file to your computer.
- Ø Click on close to return to the previous window.

Online Parts Catalog

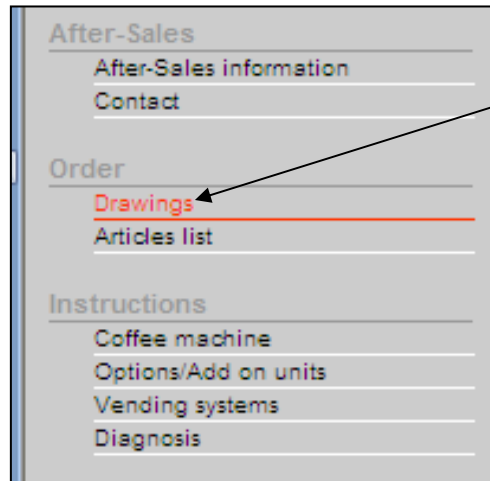

▼ Drawings

Ø Click on drawings to reach the online parts catalog with pictures or drawings of coffee machine parts.

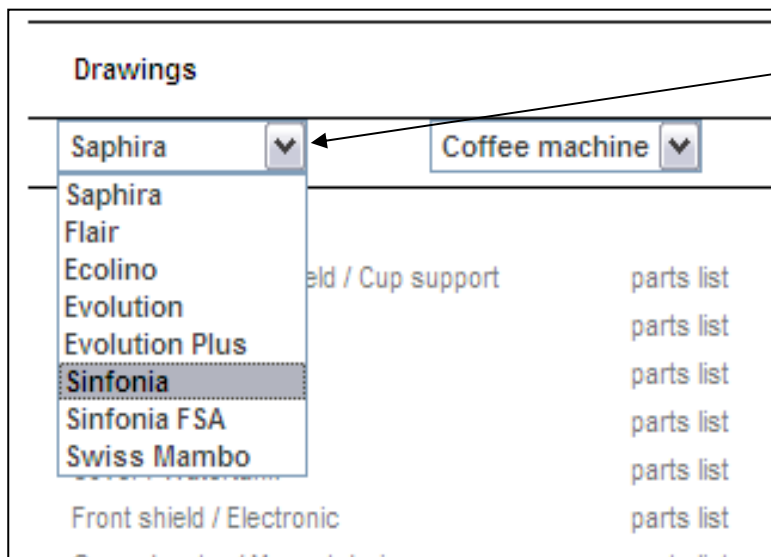

Ø Select your Franke coffee machine in the drop down menu.

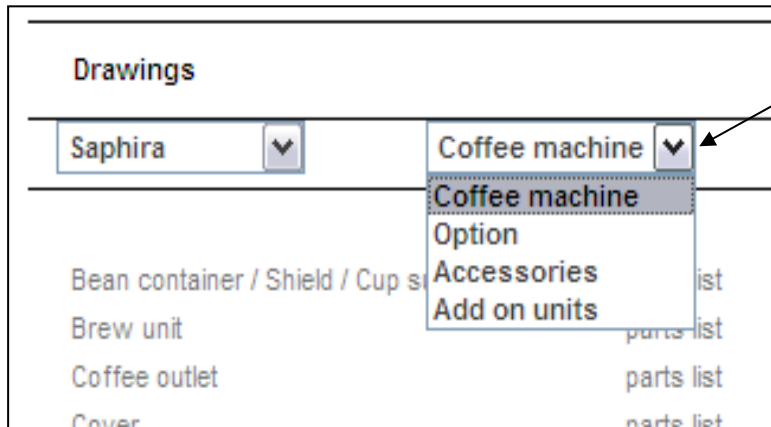

Ø Select accessories, add on units, coffee machine or option in the drop down menu to reach the correct parts catalog page.

Drawings

Sinfonia Coffee machine

- Beancontainer / shield / cup support parts list
- Boiler hotwater,Boiler Coffee parts list
- Brew unit parts list
- Cappu-systems CJ1/CJ2; CT1/CT2; CF1/CF2 parts list
- Coffee outlet parts list
- Cover parts list
- Electronic parts parts list
- Frontpanel parts list
- FSA parts list

▼ **Drawings (Continued)**

∅ To select a drawing, click on a parts group.

∅ To select only the part numbers and their description, click on "parts list" for a specific group.

Back | Only parts list

Title: Electronic parts
Description: Coffee machine
Product(s): Sinfonia

∅ Click on the position number that is associated with a part to find part number and description of part.

Back | Order/Add

Coffee machine Modul	Sinfonia Power PCB / transformer / power connection Electronic parts Evolution Plus
Pos. Number Number	5182 1Y 320 059
Title	Power print without cable
Quantity	<input type="text"/>

∅ Once position number has been selected, the title of the part and its part number for ordering is listed. (example: 1Y 320 059 is a power print without cable)

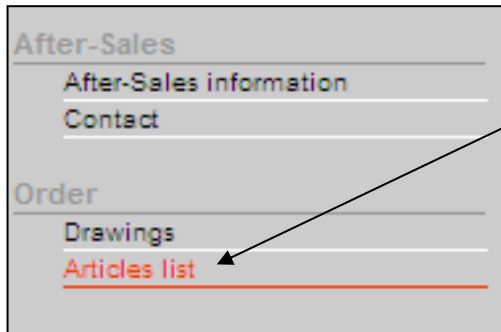

∨ Articles List

∅ Click on the Articles List to reach the parts list menu of the online parts catalog.

Articles

Sinfonia	Autosteam	
Saphira		
Flair		
Ecolino	04 Screw in spout	order
Evolution	48 O-Ring 15,6 x 1,78 mm	order
Evolution Plus	75 Pin guide 6,3mm	order
Sinfonia	20 Torque screw M4x6	order
Sinfonia FSA		
Swiss Mambo		
122	1T 310 134 Fast coupling	order
127	1T 310 024 Valve 3/2	order
133	1L 300 691 Transition nipple	order

∅ Select your Franke Coffee Machine in the pull-down menu.

Articles

Sinfonia	Autosteam	
	Autosteam	
	Back panel	der
	Base refrigeration unit	der
	Bean hopper	der
	Beancontainer / shield / cup support	der
	Beancontainer big	der
	Boiler Coffee	der
	Boiler hotwater	der
	Brew unit	der
	Cappu-systems CJ1/CJ2; CT1/CT2; CF1/CF2	der
	Chill & Cup	der
	Chip Cards	der
	Chocolate dispenser.	der
	Cleaning accessories	der
	Coffee outlet	der
	Cover	der
	Cover / Ground container	der
	Cover / watertank	der
	Cover / watertank	der
	Cup warmer	der
	Drip tray	der
	Electronic parts	der
	Evolution Plus	der
	Fixed water connection	der
	Flavour Station	der
	Foam Master	der
	Frame	der
	Front / outlet system	der
	Front shield / electronic	der

∅ Select the parts group from the pull-down menu on the right to view the parts list for that specific category.

Instructions

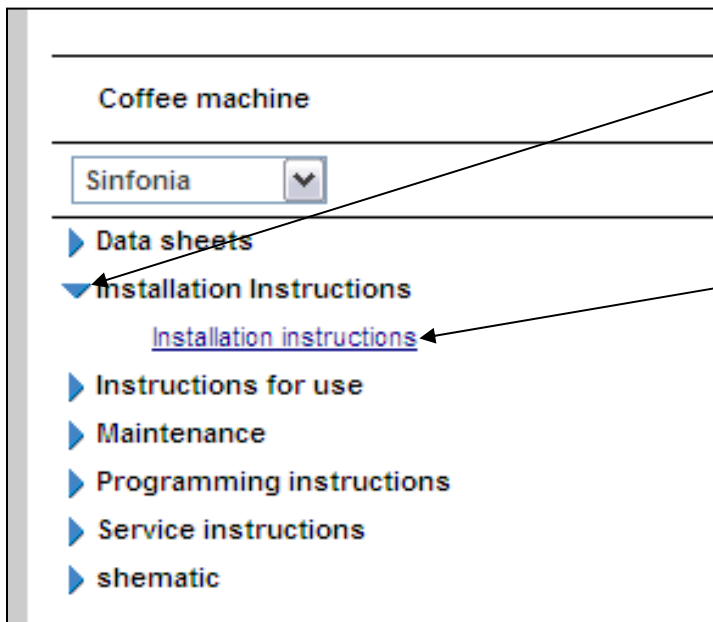
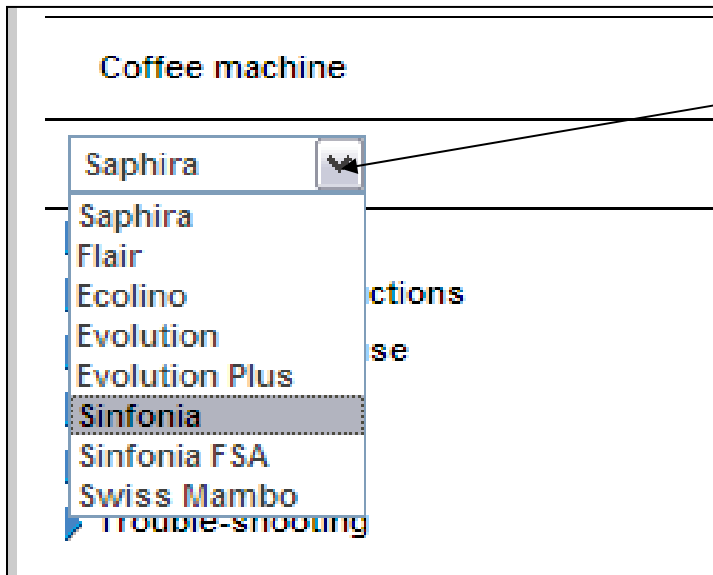
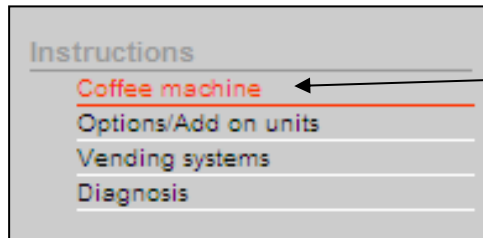

▼ **Coffee Machine**

Ø Click on the Coffee Machine to reach the instructions menu of the CSS.

Ø Select your Franke Coffee Machine in the pull-down menu.

Ø Click on the triangle icon to show details.

Ø Click on the requested document link to open the download page.

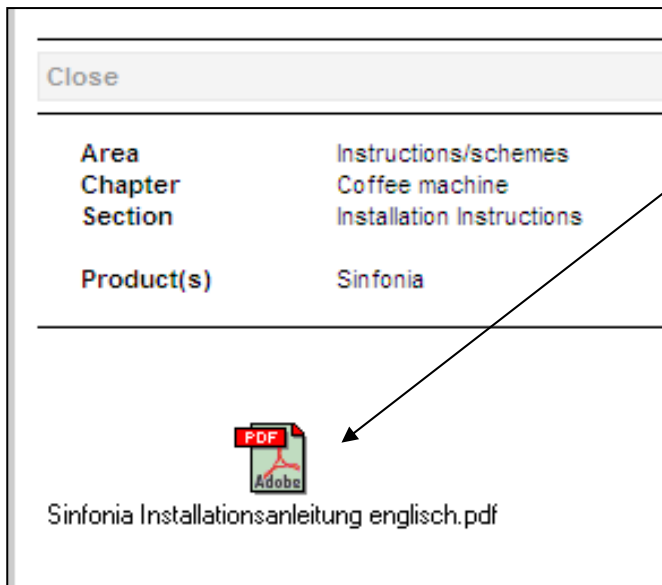

✓ **Coffee Machine
(Continued)**

Ø Click on the pdf file to open the file on your computer.

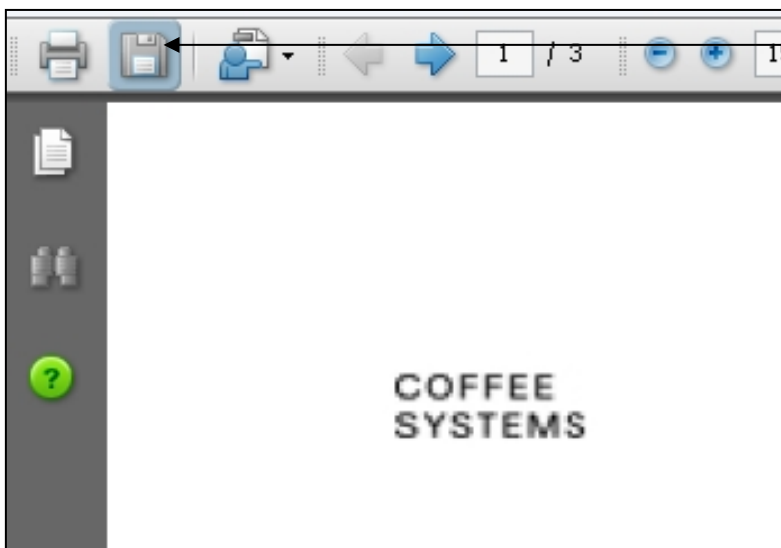

Ø To save the file on your computer, click on the “file save” icon.

Test Questions

Coffee Machine	Part Description	Part Number
Sinfonia	Upper Piston O-Ring	
	Level Probe Steam Boiler	
	Pressure Switch	
	Vacuum Valve	
	Water Pump	
	Mains Valve	
	Flow meter	
	Heater Relay	
Evolution	Upper Piston O-Ring	
	Display Print	
	Power print	
	Brewing Unit	
	Pinch Valve	
Flair	Brewing Unit	
	Encoder	

Find and Download the latest Sinfonia FSA Software (25.1rxx)

Find and Download the Service Information 08-008 (Ceramic Burrs)

Franke Sinfonia FSA

Technical Training Manual

Service Information – Chapter 10

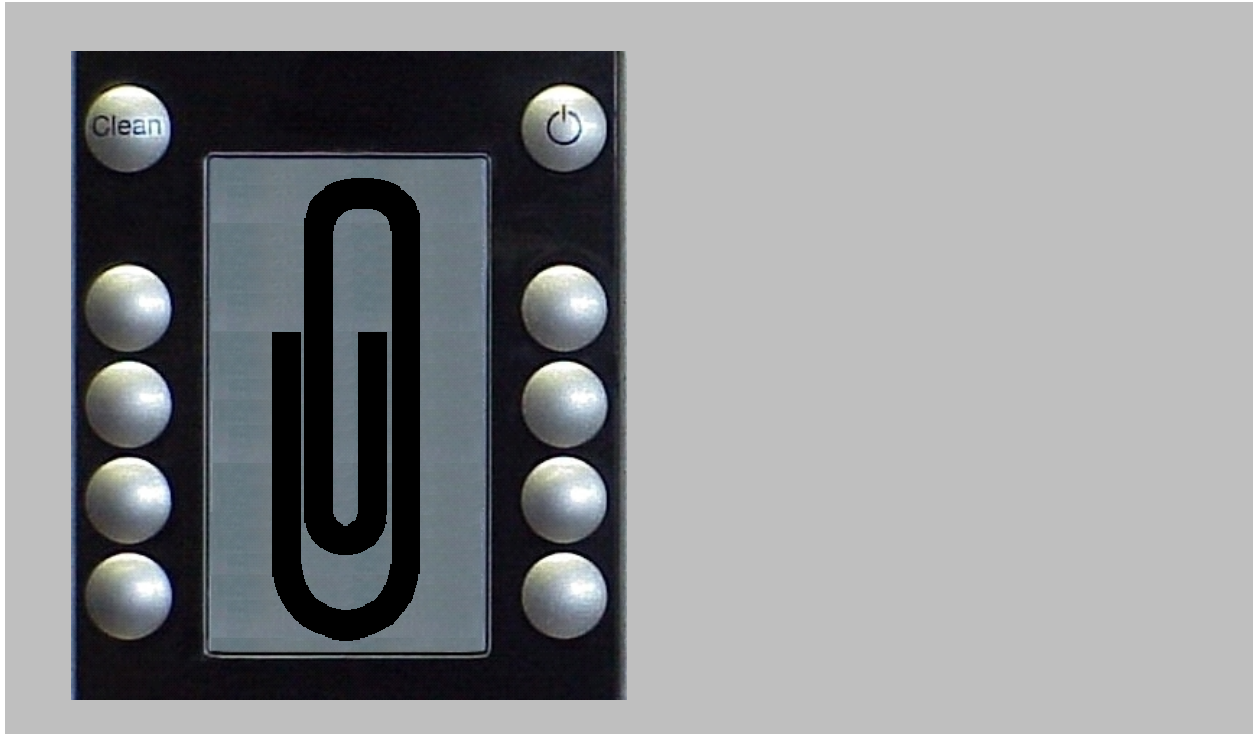

Franke Coffee Systems
800 Aviation Parkway
Smyrna, TN 37167
(615) 462-4000

Change log

Date	Changes	Author	Change No.	ID
2009-07-20	New Manual Concept	MPH		

Publisher:

Franke Kaffeemaschinen AG
 P.O. Box 235
 CH-4663 Aarburg
 Switzerland

www.franke-cs.com

Table of Contents

Change log	2
Table of Contents	3
Service Information Sinfonia / FSA	4



Service Information Sinfonia / FSA

Service Information 09 – 001

Regard: Sinfonia FSA

Validity: 20.03.2009 downwards compatible: no



Warning: Always disconnect the coffee machine from the mains before opening it

Quick-Disconnect “Coffee Stick” for McDonald’s Sinfonia FSA

Previous article
Ø –

New article
Ø CBB 1002 – Coffee Stick

We are currently experiencing a very high rate of calls in which the quick-disconnect on the “coffee stick” becomes disconnected, stopping water flow to the Sinfonia espresso machine.

We’ve found that when the McD crew members move the machine and fridge to clean behind it, the button on the quick-disconnect gets bumped and disconnects, disrupting the water flow.

To help lessen the likelihood of this happening in the future, McDonald’s has asked us to install zip ties under the button to prevent it from being pressed hard enough to disconnect accidentally.

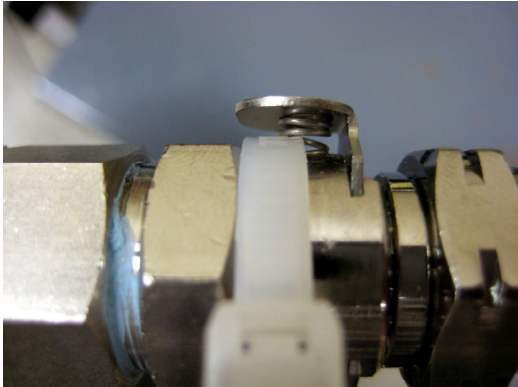

Coffee Stick – CBB 1002 with Zip-Tie

IMPORTANT!
On all future installs, service calls or PM’s we’d like you to install the zip-tie as indicated in the picture above. Ensure the zip-tie is placed in the spring under the button lever. Use a 7.5 or 8” zip-tie as this size is wide enough to remain in place without dislodging from the spring.

Franke Coffee Systems
North America, Inc.
5601 1st Avenue South
Seattle, WA 98108

USA
Phone: +1 206 784 9563
www.franke-cs.com

Author
John Simpson
Account Manager
McDonald’s Account
FCSNA

Authorization
Roman Probst
Product Management
FCSNA

Service Information

09 – 002

Regard: Sinfonia

Validity: 20.04.2009

downwards compatible: yes



Warning: Always disconnect the coffee machine from the mains before opening it

Door Latch Torque Information

Previous article

☛ –

New article

☛ –

We are currently experiencing an increase in calls concerning the malfunction of the door latch on the Sinfonia coffee machine. The door latch will not release, preventing the grounds door from opening, or the door latch will not close, preventing the grounds door from closing.

We've found that the door latch malfunction is due to over tightening in production. This issue has been addressed at the factory beginning with machines manufactured after 2009-03-19 date.

When replacing the door latch, be careful not to over tighten the bolts securing the latch to the frame. Tighten the two nuts to the following torque:

☛ 0.55Nm / 0.4 ft/lb (5.5Ncm / 4.8 in/lb)

IMPORTANT!

We recommend using a torque screwdriver similar to the one in illustration 01



Illustration 01

Torque Increments: 2.0 in. lbs./0.2 Nm

Torque Measure: 2 to 36 in. lbs./0.2 to 4 Nm

Franke Coffee Systems
North America, Inc.
5601 1st Avenue South
Seattle, WA 98108

USA
Phone: +1 206 784 9563
www.franke-cs.com

Author
Peter Mettler
Support International
Franke Coffee Systems

Authorization
Roman Probst
Product Management
FCSNA

Service Information

09 – 003-A (Replaces 09-003)

Regard: Evolution, Sinfonia and Sinfonia FSA

Validity: June 01, 2009 downwards compatible: yes



Warning: Always disconnect the coffee machine from the mains before opening it

New Pressure Switch Trafag (This document replaces Service Information 09-003)

Previous article

➤ 10 300 869 – pressure switch

New article

➤ 1T 311 861 – pressure switch Trafag
 ➤ 1T 311 862 – adapter harness
 (included with 1T 311 861)

The manufacturer Franke has approved a new supplier for the pressure switch used on all Evolution, Sinfonia and Sinfonia FSA coffee machines.

When ordering this new pressure switch (1T311861), the adapter harness is included.

IMPORTANT!

This new pressure switch is preset to 1.8bar and does not require any adjustment at installation.

Do not attempt to make any adjustments to this pressure switch.

If you are dispatched to service an Evolution, Sinfonia or Sinfonia FSA coffee machine to fix a steam pressure issue or to replace a pressure switch during a PM, install only this new Trafag pressure switch.

The older version (part number 300869) is discontinued with immediate effect and should no longer be used on any Franke Evolution, Sinfonia or Sinfonia FSA coffee machines.

Remove covers on pins 11 and 12 to connect adapter harness.
 Pin 11 = white
 Pin 12 = orange



Trafag Pressure switch and adapter harness

Parts Ordering

When ordering the pressure switch for parts stock, order only the new pressure switch.

Parts are available as of June 1, 2009

Franke Coffee Systems
 North America, Inc.
 5601 1st Avenue South
 Seattle, WA 98108

USA
 Phone: +1 206 784 9563
www.franke-cs.com

Author
 Peter Mettler
 Support International
 Franke Coffee Systems

Authorization
 Roman Probst
 Product Management
 FCSNA

Service Information

09 – 006

Regard: Evolution, Sinfonia and Sinfonia FSA

Validity: June 01, 2009 downwards compatible: yes



Warning: Always disconnect the coffee machine from the mains before opening it

New Manometer (pressure gauge) for Steam Pressure Reading

Previous article

Ø 1L 300 962 – manometer 4 bar

New article

Ø 1Y 320 826 – manometer 4 bar

The manufacturer Franke has approved a new supplier for the manometer 4 bar used to measure the pressure in the steam boiler in all Evolution, Sinfonia and Sinfonia FSA coffee machines.

IMPORTANT!

If you are dispatched to service an Evolution, Sinfonia or Sinfonia FSA coffee machine and the manometer 4 bar is found to be damaged, replace it only with the new manometer.



Manometer 4 bar 1Y 320 826

The older version (part number 300962) is discontinued with immediate effect and should no longer be used on any Franke Evolution, Sinfonia or Sinfonia FSA coffee machines.

Parts are available as of June 1, 2009

Franke Coffee Systems
North America, Inc.
5601 1st Avenue South
Seattle, WA 98108

USA
Phone: +1 206 784 9563
www.franke-cs.com

Author
Peter Mettler
Support International
Franke Coffee Systems

Authorization
Roman Probst
Product Management
FCSNA

Device family	Device type	Assembly
Evolution	all	Brewing unit
Sinfonia	all	Brewing unit

Service Information

09-164

Replaces

Change Order

00394

Date

2009-11-23

Guide Rod for brewing unit

Old parts		New parts		Available	Compatible
1T310278	Guide shaft for brewing unit	1T312206	Guide rod for brewing unit	2009-12-02	Yes

Reason for change The material and surface hardness of the guide rod have been adapted. The service life of the guide rod is increased by this measure.

Tools

- none

Additional materials

- none

NOTE

Instead of hard chromium plating, Duralloy will now be **matt** coated.

The new rod will be installed from brewing unit number 52553 upwards.

Available documents	Document number	Document title	Document type
	none		

Author Horst Schneeberger
Support International

Release Heinz Oberholzer
Research & Development

Device family	Device type	Assembly
Spectra	S / X	Grinder
Evolution	All	Grinder
Ecolino	All	Grinder
Ecopower	All	Grinder
Sinfonia	All	Grinder

Service Information

10-106

Replaces

Change Order

00461

Date

2010-06-19

Klüber paste for grinder

Old parts		New parts		Available	Compatible
		1H327583	Klüber paste UH1 84-201 / 1g	Yes	Yes
BK325971	Ceramic grinding wheel kit	BK325971	Ceramic grinding wheel kit	Yes	Yes
BK326566	Fixed-wheel flange incl. sealing ring	BK326566	Fixed-wheel flange incl. sealing ring	Yes	Yes
BK310148	Grinder cutter set Ditting D= 54 mm	BK310148	Grinder cutter set Ditting D= 54 mm	Yes	Yes
BK311725	Conversion kit to ceramic blades Evo	BK311725	Conversion kit to ceramic blades Evo	Yes	Yes
BK320349	Grinder cutter set d=64	BK320349	Grinder cutter set d=64	Yes	Yes

Reason for change Every time the grinder is serviced or the grinder cutters are replaced, the threading and the contact surfaces of the grinder and the adjustment ring have to be cleaned and then coated with Klüber paste. The Klüber paste is in a 1g sachet which is enclosed with the grinder cutter sets/conversion kits listed above.



Klüberpaste
UH 1 84-201

Use only for
adjustment thread

Art.-No. 55105

1g

Fig. 1: Message on the sachet packaging

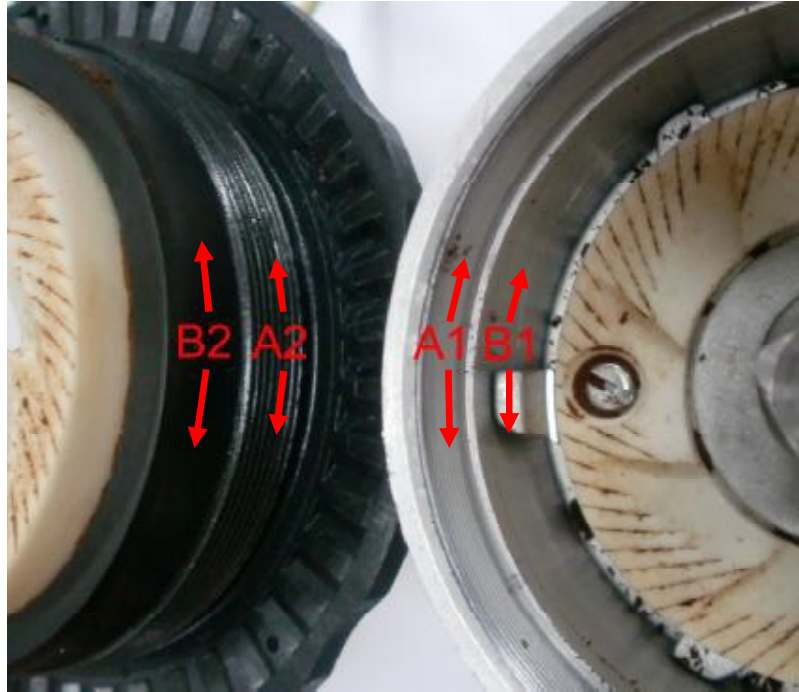

Fig. 2: Threading and contact surfaces

Item	Description
A1	Grinder threading
A2	Adjustment ring threading
B1	Grinder contact surfaces
B2	Adjustment ring contact surfaces

Note The contents of the sachet is enough for one grinder and must be completely applied to the threading and contact surfaces of the grinder.

Author Marcel Portmann
Support International

Release Michael von Däniken
Research & Development

Device family	Device type	Assembly
Ecolino	all	Boiler group
Ecopower	all	Boiler group
Evolution Basic	all	Boiler group
Evolution Top	all	Boiler group
Evolution Plus	all	Boiler group
Sinfonia	all	Boiler group
Sinfonia FSA	all	Boiler group
Swiss Mambo	all	Boiler group

Service Information

10-114

Replaces

Change Order

00474

Date

2010-08-13

Level sensor

Old parts		New parts	Available	Compatible
1L300072	Level sensor	BK320972	Level sensor l=93.5mm	Evolution Basic, Ecolino, Swiss Mambo
		BK320973	Level sensor l=75mm	Evolution Top, Evolution Plus, Sinfonia, Sinfonia FSA, Ecopower

Reason for change More resistant against scaling
Simpler to install/remove

Tools

- Open-ended wrench 12 mm

Additional materials

- None

DANGER

Risk of scalding

Before replacing the level sensor, it is imperative to ensure that the hot water/steam boiler is completely depressurized and has cooled down.

Measures The existing 1L300072 is replaced by 2 level sensors with different lengths. Their surfaces are electropolished, thus reducing their surface roughness. This surface finish reduces scaling adhesion to the probe.

In order to facilitate installation/removal during maintenance, the new level sensor is fixed with a quick-action coupling system.



Fig. 1) Level sensor l = 93.5mm (BK320972)



Fig. 2) Level sensor l = 75mm (BK320973)

NOTE

The next time a level sensor is ordered, it is essential to use as per the instructions in Table 1:

Use in device family:	Level sensor l = 93.5mm BK320972	Level sensor l = 75mm BK320973
Evolution Basic	X	
Evolution Top		X
Evolution Plus		X
Sinfonia		X
Sinfonia FSA		X
Ecolino	X	
Ecopower		X
Swiss Mambo	X	

Table 1: Areas of application of level sensors



Available documents	Document number	Document title	Document type

Author Joerg Braun
Support International

Release Michael von Däniken
Research & Development

Device family	Device type	Assembly
Sinfonia	all	Ground container / drip tray

Service Information

10-116

Replaces

Change Order

00480

Date

2010-03-29

Steam deflection plate

Old parts	New parts	Available	Compatible
	1Y320974	Steam deflection plate	2010-03-16 Yes

Reason for change By installing the steam deflection plate, the steam escaping from the overflow tube is guided to the outside and does not condense in the machine.

Tools • Torx 20

Additional materials • none



Fig. 1: Steam deflection plate 1Y 320 974

Aim The steam deflection plate has been introduced in the production according to the following table.

Coffee machine	Machine number	Start date
Sinfonia, all	00005487	2010-03-16



Available documents	Document number	Document title	Document type
	none		

Author Horst Schneeberger
Support International

Release Michael von Däniken
Research & Development

Device family	Device type	Assembly
Evolution	Basis / Top / Plus	Hot water valve block
Sinfonia	all	Hot water valve block

Service Information

10-119

Replaces

09-130

Change Order

00419 / 00268

Date

2010-03-11

Vacuum valve complete

!!! Replaces Service Information 09-130 !!!

Old parts	New parts	Available	Compatible
1L297158 ¼" vacuum valve (steam)	1T311952 Vacuum valve cpl.	2009-12-04	Yes
1T310422 O-Ring 9.19 x 2.62	1T310422 O-Ring 9.19 x 2.62		

Reason for change The vacuum valve is now made out of PEEK. This change in material prevents the piston inside the valve from sticking.

Tools • none

Additional materials • special grease 1L296804

NOTE

Assembly

The vacuum valve must not be over-tightened during assembly.

- Lubricate the O-ring (A) with a little special grease 1L296804.
- Installation direction distance disc (B) according to the illustration
- Tighten the valve up to the O ring.
- Then tighten with a 1/6 rotation.

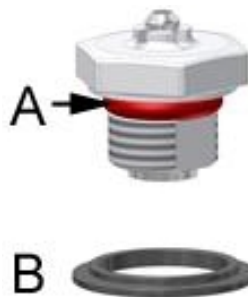

Fig. 1: Vacuum valve 1T311952

A	1T310422	O-ring \varnothing 9.19 x 2.62
B		Distance disc

Aim The vacuum valve was introduced into production based on the following table.

Coffee machine	Machine number	Start date
Evolution (Basic / Top / Plus)	00003709	2009-12-08
Sinfonia	00003592	2009-12-04

Requirements none

Measures none

Available documents	Document number	Document title	Document type
	none		

Author Marco Probst
Support International

Release Michael von Däniken
Research & Development

Device family	Device type	Assembly
Sinfonia	all	Frame

Service Information

10-133

Replaces

Change Order

00477 / 00524

Date

05-31-2010

Optimization of steam block

Old parts		New parts		Available	Compatible
10300349	Y-piece	1T310953	Hose joint piece	05.17.2010	Yes
BK300450	Silicone hose 10 x 1.5 x 740	BK300450	Silicone hose 10x1.5 mm (L = 800 mm)	05.17.2010	Yes
		BK300450	Silicone hose 10x1.5 mm (L = 80 mm)	05.17.2010	Yes
		BK321029	Holder with hose	CW (calendar week) 26	Yes

Reason for change With the new hose layout, the steam is directed more efficiently to the outside of the machine.
The pressure switch is no longer subjected to overheating due to relocation away from pressure block.

CAUTION

Risk of scalding

- Before starting work on the hoses or installing the holder for the pressure block, it is essential to ensure that the hot water / steam boiler is absolutely depressurized and cooled!

1) New hose arrangement for pressure block

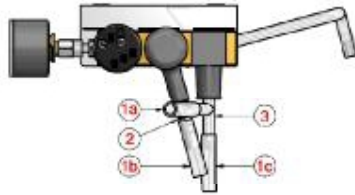

Fig. 1: Piping for pressure block

Item	Item number	Name
1a	BK300450	Silicone hose 10x1.5 mm (L = 80 mm)
1b	BK300450	Silicone hose 10x1.5 mm (L = 500 mm)
1c	BK300450	Silicone hose 10x1.5 mm (L = 800 mm)
2	1T310953	Hose joint piece
3	1Y320596	T - piece

Aim The new piping for the "pressure block" will be introduced into production models as per the following table.

Coffee machine	Machine number	Date of introduction
Sinfonia, all	00006722	05.17.2010

2) Relocation of pressure switch

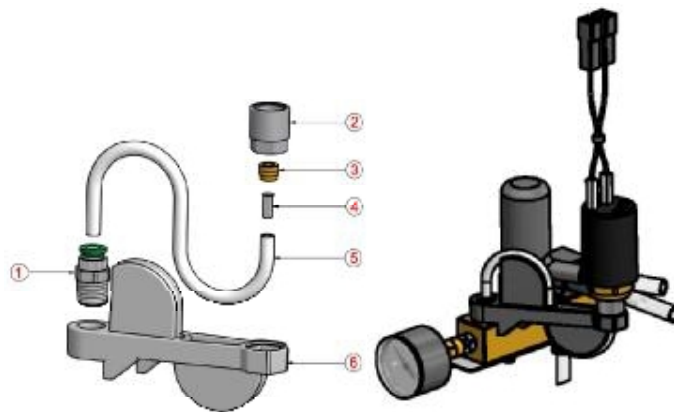

Fig. 2: Holder for pressure switch BK 321 029

Item	Name
1	Plug coupling
2	Connecting nut SO 000216-1/4CV
3	Clamp ring
4	Serto support bracket
5	Teflon hose 6x4 mm (L = 180 mm)
6	Pressure block holder for Sinfonia

Aim The relocation of pressure switch will be introduced into production models as per the following table.

Coffee machine	Machine number	Date of introduction
Sinfonia	00007572	28.06.2010
Sinfonia FSA	00007226	26.06.2010

Author Horst Schneeberger
Support International

Release Reto Haefliger
Research & Development

Device family	Device type	Assembly
Sinfonia	All	Heating unit

Service Information

10-135

Replaces

Change Order

00234

Date

09-06-2010

Pressure block pipe

Old parts		New parts		Available	Compatible
1Y320192	Pressure block pipe	1Y320828	Pressure block pipe	06.09.2010	No
1L301641	Double nipple	1Y320827	Straight screw connection	06.09.2010	No
1T310817	Angle screw connection	1Y320827	Straight screw connection	06.09.2010	No

Reason for change A lot of heat is conducted by the metal pipe between the boiler and pressure block. This can cause calcification of the angled screw-in connection, located on the boiler. The changed pipe design prevents excess heat conduction and simplifies installation. Scaling in the pipe is also clearly visible.

Tools • None

Additional materials • None

Aim From 9 June 2010 (machine serial number: 00007197), the new pipe between the boiler and pressure block will be installed in all Sinfonia coffee machines.

Requirements None

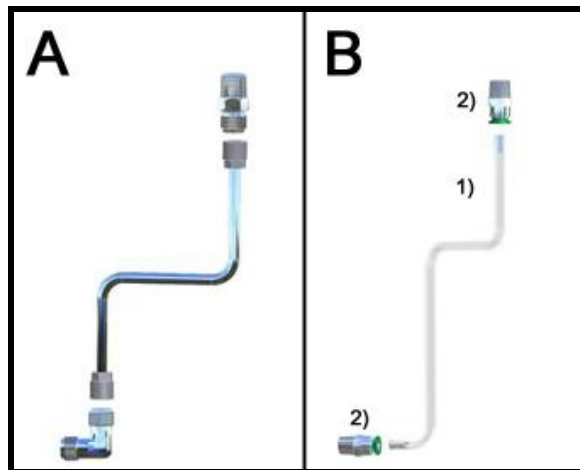

Fig. 1: Pressure block pipe previous / now

A Existing pressure block pipe

B New pressure block pipe

1) Pipe for pressure block (1Y320828) incl. supporting sleeves

2) Straight screw-in connection (1Y320827)

Measures None

Available documents	Document number	Document title	Document type
	None		

Author Marco Probst
Support International

Release Reto Häfliger
Research & Development

Device family	Device type	Assembly
Evolution	All	Waterways
Evolution Plus	All	Waterways
Sinfonia	All	Waterways
Spectra	All	Waterways

Service Information

10-139

Replaces

Change Order

00547

Date

2010-12-09

Threaded elbow fitting

Old parts		New parts		Available	Compatible
1T310134	Plug coupling	1T310134	Plug coupling	2010-12-09	Yes

Reason for change The cylindrical thread makes it possible to tighten the threaded elbow fitting by a defined amount (1T310134).

Tools • None

Additional materials • None

Aim Introduction of the threaded elbow fitting with cylindrical thread and O-ring seal:

Device family	Date of introduction	Machine serial number
Evolution	2010-12-09	00010027
Evolution Plus	2010-12-09	00010027
Sinfonia	2010-12-09	00010027
Spectra	2010-12-09	00010027
Pura	2010-12-09	00010027
Saphira/Flair	2010-12-09	00010027

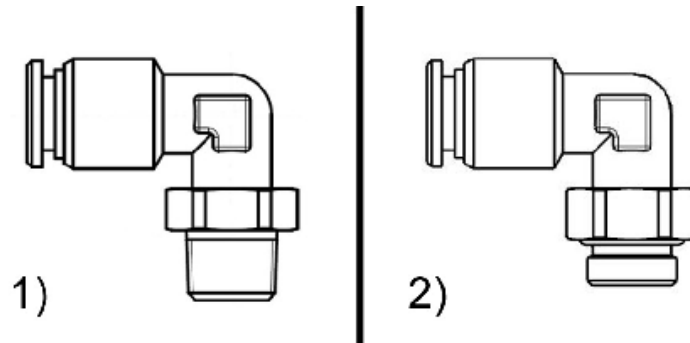

Fig. 1: Threaded elbow fitting 1T310134 (previous/new)

1) Threaded elbow fitting 1T310134, previous (conical thread)

2) Threaded elbow fitting 1T310134, new (metric thread)

Requirements None

Measures None

Available documents	Document number	Document title	Document type
	None		

Author Marco Probst
Support International

Release Michael von Däniken
Research & Development

Device family	Device type	Assembly
Sinfonia	Milk system UL	Milk system CF
Sinfonia	Milk system	Milk system CF
Evolution	Milk system Basic	Milk system CF
Evolution	Milk system Top	Milk system CF
Evolution	Milk system Top Plus	Milk system CF

Service Information

10-141

Replaces

Change Order

00538

Date

2010-08-25

Check valve for milk system CF

Old parts		New parts		Available	Compatible
1H326168	Outlet check valve	1N330103	Check valve	2010-07-28	Yes

Reason for change Complaints about the currently used check valve. Reduction of number of parts. Same check valve as for Evolution, Sinfonia and Pura.



Fig. 1: Check valve 1H326168 (left) and check valve 1N330103 (right)

Available documents	Document number	Document title	Document type
	None		

Author Horst Schneeberger
Support International

Release Michael von Däniken
Research & Development

Device family	Device type	Assembly
Sinfonia	all	Coffee outlet Height adjustment

Service Information

10-142

Replaces

Change Order

00545

Date

2010-08-30

Cable for outlet switch

Old parts	New parts	Available	Compatible
	BK320684	Cable for outlet switch 2010-06-02	Yes
	1Y320900	Cable for REED outlet switch 2010-06-02	Yes

Reason for change The cable included in the cable loom "cable for the outlet switch" is removed from the cable loom and is carried as an individual part.

Measures



Fig. 1: Cable outlet switch **BK320684**



Fig. 2: Cable for REED outlet switch **1Y320900**

Available documents	Document number	Document title	Document type
	TD-102193.doc	Coffee outlet magnet - reed switch mounting	PDF

Author Horst Schneeberger
Support International

Release Michael von Däniken
Research & Development

Device family	Device type	Assembly	Service Information
Evolution	All	Fixed water connection	10-148
Evolution Plus	All	Fixed water connection	Replaces
Sinfonia	All	Fixed water connection	Change Order
Spectra	All	Fixed water connection	00544
Saphira/Flair	Fixed water connection	Fixed water connection	Date 0211-02-01

Metallic hose

Old parts		New parts		Available	Compatible
1L297184	Metallic hose	1L297184	Metallic hose	03.02.2011	Yes

Reason for change Due to the reduction of the hose diameter, the hose is easier to bend and can thus be better positioned during installation

Tools • None

Additional materials • None

Aim Introduction of new armored hose:

Device family	Date of introduction	Machine serial number
Evolution	03.02.2011	00013185
Evolution Plus	03.02.2011	00013185
Sinfonia	03.02.2011	00013188
Spectra	10.02.2011	00013414
Saphira/Flair	16.03.2011	03005514

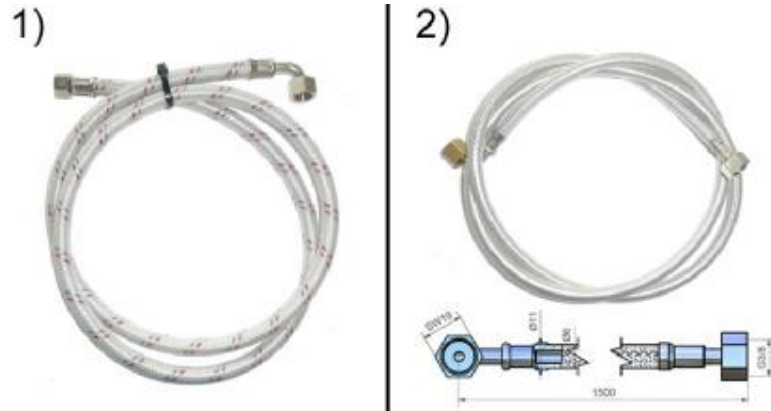

Fig. 1 Comparison of armored hose previous / new

1) Metallic hose previous Ø 8 mm

2) Metallic hose new Ø 6 mm

Requirements None

Measures None

Available documents	Document number	Document title	Document type
	None		

Author Marco Probst
Support International

Release Michael von Däniken
Research & Development

Device family	Device type	Assembly	Service Information
Sinfonia	All	Boiler Hot water Grounds container Drip tray	10-154 Replaces
Evolution	All		Change Order 00566
Spectra	All		Date 2010-09-14

Change in plug coupling

Old parts		New parts		Available	Compatible
BK321029	Pressure block holder	BK321029	Pressure block holder	Jan. 2011	Yes
1T310133	Plug coupling	1T310133	Plug coupling	27.09.2010	No
1T310132	Plug coupling	1T310132	Plug coupling	23.09.2010	No
1Y320655	Overflow pipe FSA complete	1Y320655	Overflow pipe FSA complete	Jan. 2011	No

Reason for change New comestibles regulations in relation to lead and nickel rinsing, of components, in potable water.



Fig. 1: Plug couplings

Item			Available to	Available from
a	1T310132	Plug coupling	22.09.2010	
b	1T310132	Plug coupling		23.09.2010
c	1T310133	Plug coupling	26.09.2010	
d	1T310133	Plug coupling		27.09.2010

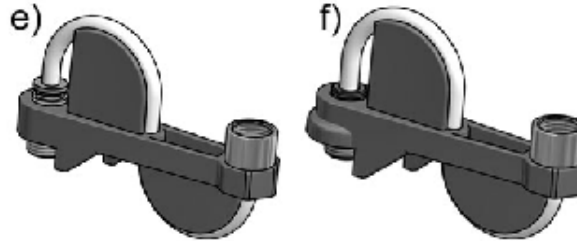

Fig. 2: Pressure block holder

Item	Available to	Available from
e BK321029 Pressure block holder	Jan. 2011	
f BK321029 Pressure block holder		Jan. 2011

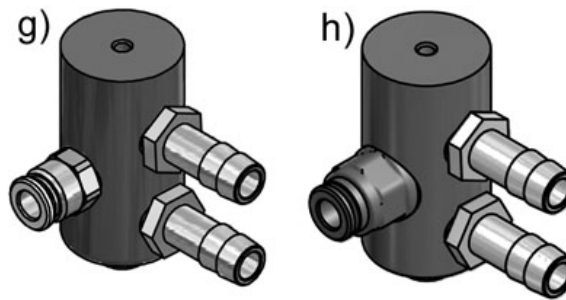

Fig. 3: 1Y320655 overflow pipe FSA complete

Item	Available to	Available from
g 1Y320655 Overflow pipe FSA complete	Jan. 2011	
h 1Y320655 Overflow pipe FSA complete		Jan. 2011

Available documents	Document number	Document title	Document type
	None		

Author Horst Schneeberger
Support International

Release Michael von Däniken
Research & Development

Device family	Device type	Assembly
Evolution	All	Pressure gauge
Evolution Plus	All	Pressure gauge
Sinfonia	All	Pressure gauge
Spectra	All	Pressure gauge

Service Information

10-158

Replaces

Change Order

00580

Date

2011-02-11

Manometer 6 bar

Old parts		New parts		Available	Compatible
1Y320826	Manometer 4 bar	1H327826	Manometer 6 bar	01.02.2011	Yes

Reason for change It must be possible to read the complete test range of the safety valve on the Manometer. In order to test the 4bar security valve on the Spectra, a 6 bar Manometer is needed.

Tools • None

Additional materials • None

Note No material or dimensional change

Aim Introduction of pressure gauge 6 bar:

Device family	Date of introduction	Machine serial number
Evolution	08.02.2011	00013301
Evolution Plus	08.02.2011	00013301
Sinfonia	03.02.2011	00013207
Spectra	01.02.2011	00013144



Abb. 1: Manometer 6bar 1H327826



COFFEE
SYSTEMS

Franke Kaffeemaschinen AG Franke-Strasse 9 4663 Aarburg Switzerland Hotline: +41 62 787 37 37 Fax: +41 62 787 97 37 www.franke.com

Requirements None

Measures None

Available documents	Document number	Document title	Document type
	None		

Author Marco Probst
Support International

Release Michael von Däniken
Research & Development

Device family	Device type	Assembly
E-line	All	Various
Sinfonia	All	Various

Service Information

10-165

Replaces

Change Order

00632

Date

2010-11-02

O-rings

Old parts		New parts		Available	Compatible
BK310192	O-ring D=8.73x1.78	BK310192	O-ring D=8.73x1.78	2010-11-01	Yes
1L301007	O-ring D=6.07x1.78 to outlet	1L301007	O-ring D=6.07x1.78 to outlet	2010-11-01	Yes
1T310646	O-ring D=28.3x1.78	1T310646	O-ring D=28.3x1.78	2010-11-01	Yes

Reason for change New regulations concerning the materials coming into contact with foodstuffs.

There can be differences in color in comparison with the previous O-rings.

Tools

- none

Additional materials

- none

Available documents	Document number	Document title	Document type

Author Horst Schneeberger
Support International

Release Michael von Däniken
Research & Development

Device family	Device type	Assembly
Sinfonia	All	Heating unit

Service Information

11-127

Replaces

Change Order

00622

Date

2011-06-20

Vacuum valve protection cap, washer

Old parts		New parts		Available	Compatible
1Y 320597	Protection cap	1Y 321075	Protection cap type 15-684	20.06.2011	Yes
1T 312653	Washer	1Y 320598	Washer	20.06.2011	Yes

Reason for change Washer: Heat resistance
Protection cap: Heat resistance

- Tools**
- Torque wrench with width across flats of 19 or open-end wrench size 19

DANGER

Risk of scalding

- Before replacing the washer, it is essential to ensure that the hot water/steam boiler is absolutely pressure-free and has cooled down.

Aim The protection cap has been changed to heat-resistant silicone. The color of the protection cap is now gray (previous color: black).
The washer is now made of brass (previous material: polyamide).

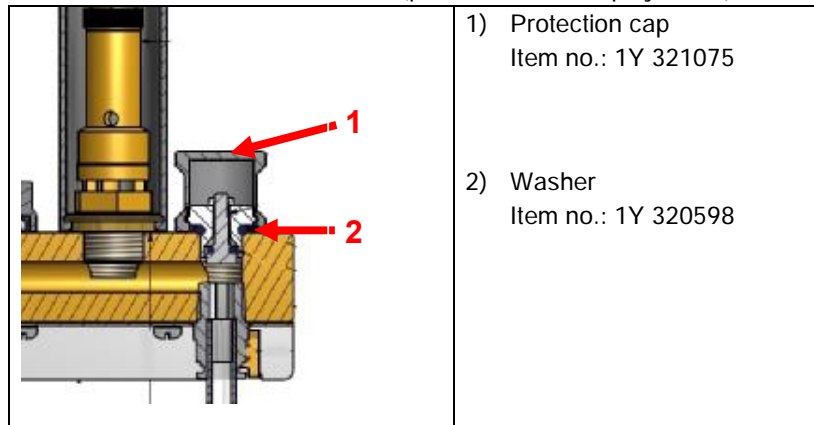

Fig. 1: Section through Sinfonia pressure block

Tightening torque of the vacuum valve: (item no.: 1T 311952)

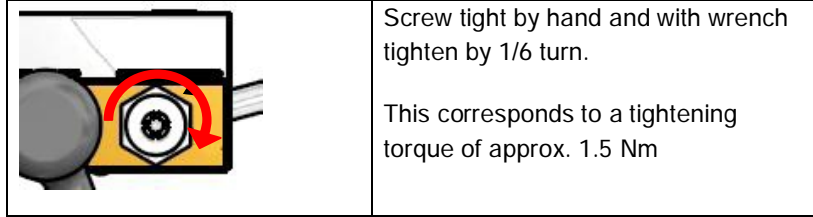

Fig. 2 Section of top of Sinfonia pressure block

Available documents	Document number	Document title	Document type
	none		

Author Joerg Braun
Support International

Release Michael von Däniken
Research & Development

Device family	Device type	Assembly
Evolution	All	Coffee outlet
Sinfonia	All	Coffee outlet

Service Information

11-128

Replaces

Change Order

00835

Date

2011-05-13

Complete outlet with magnet

Old parts	New parts	Available	Compatible
	BK 321079	2011-05-23	In part

Reason for change Spare parts number so that the complete outlet with magnet (Fig. 1) can be ordered for an existing coffee machine.

Tools • None

Additional materials • None

Requirements In the existing coffee machine, the outlet being replaced must also be equipped with a magnet.



Fig. 1: Outlet with magnet, art. no.: BK 321079

Available documents	Document number	Document title	Document type
	None		

Author Jörg Braun
Support International

Approved Michael von Däniken
Research & Development

Device family	Device type	Assembly
Sinfonia	All	Brewing unit

Service Information

11-140

Replaces

Change Order

00679

Date

2011-06-21

Brewing unit 01, drive motor support

Old parts	New parts	Available	Compatible
	1Y321086 Bumpon 3M SJ-5023 black	22.06.2011	Yes

Reason for change If brewing unit 01 moves to the upper stop, it is possible that the toothed belt on the motor pinion jumps. This happens because the DC motor is tilted during torque transmission. At this moment, the belt tension is no longer adequately ensured.

Tools • none

Aim The Bumpon prevents the tilting of the DC motor by forming a support against the outlet guide attachment plate (see Fig. 1).

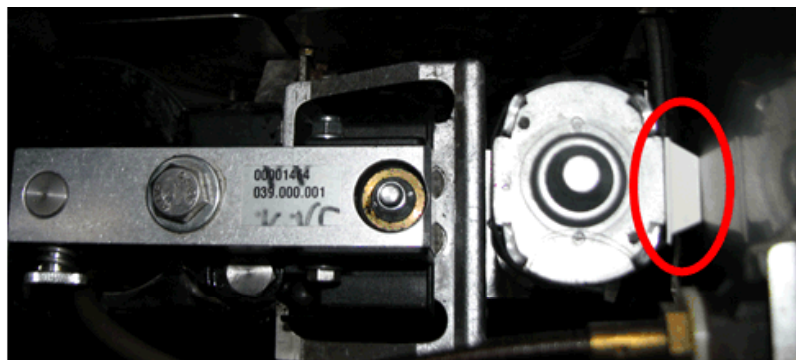

Fig. 1: Sinfonia 01 brewing unit, compl. (item no.: BK320248), now with Bumpon (item no.: 1Y321086)

Note In future, the complete Sinfonia 01 brewing unit (item no.: BK320249) and the DC motor (item no.: 1Y320948) will be equipped with the Bumpon (item no.: 1Y321086) which will also be available as a spare part.

Available documents	Document number	Document title	Document type
	none		

Author Yves Hionas
Technical Product Support

Release Michael von Däniken
Research & Development

Device family	Device type	Assembly
Sinfonia	All	Brewing unit

Service Information
11-147
Replaces
Change Order
00860
Date
2011-07-18

BG01, large toothed wheel

Old parts		New parts		Available	Compatible
1Y320016	Large toothed wheel z=56	1Y321083	Large toothed wheel	2011-07-11	Yes

Reason for Change Lower moment of inertia improves dynamics.

Tool • None

Aim The previous sintered "large toothed wheel z=56" (1Y320016) is being replaced with the die-cast "large toothed wheel" (1Y321083). This plastic is already being used with the pinion on the DC motor (1Y320948).

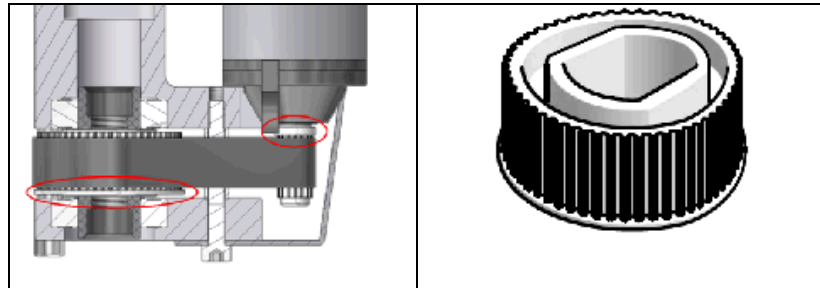

Fig. 1: Mounted large toothed wheel (item no.: 1Y321083)

Fig. 2: Large toothed wheel (item no.: 1Y321083) with a contact surface

Notice The large toothed wheel (1Y321083) must be mounted as displayed in Fig. 1.

Available documents	Document number	Document title	Document type
	None		

Author Yves Hionas
Technical Product Support

Approved Michael von Däniken
Research & Development

Device family	Device type	Assembly
Sinfonia	UL versions	Electronics
Evolution	UL versions	Electronics

Service Information

11-148

Replaces

Change Order

00888

Date

2011-07-30

UL units: fuse modification

Old parts	New parts	Available	Compatible
1Y320401	Fuse FST 5x20 16 A BK 321097	Fuse 6.3x32 16 A with casing	2011-09-19 Yes

Reason for Change New approval requirements.

Tools • None

Aim The fuse FST 5x20 16A (1Y320401) is being replaced with the fuse A12BK 6.3x32. The fuse, however, has different dimensions. To ensure backwards compatibility, the fuse is offered complete with a casing (see Fig. 1).

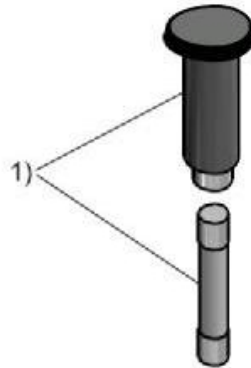

Fig. 1: Fuse ~~6.3x32 16 A~~ with casing (item no.: BK321097)

1) Fuse 6.3x32 16 A with casing (item no.: BK321097)



Available documents	Document number	Document title	Document type
	None		

Author Yves Hionas
Technical Product Support

Approved Michael von Däniken
Research & Development

Device family	Device type	Module
Sinfonia	All	Front panel

Service Information
12-103
Replaces
Change Order
01116
Date
2012-03-15

User print seal; change in material

Old parts		New parts		Available	Compatible
1Y320681	User print seal/HW-D print	1Y320681	User print seal/HW-D print	2012-03-15	Yes
1Y320672	User print with FFSTN display	BK321180	Sinfonia user print	2012-03-15	Yes

Reason for change The seal material previously used ages too quickly and becomes brittle. This can result in an insufficient sealing of the user print.

Tools • None

Aim The new sealing material (PE30) will prevent the seal from becoming brittle, which ensures that the user print is sealed.

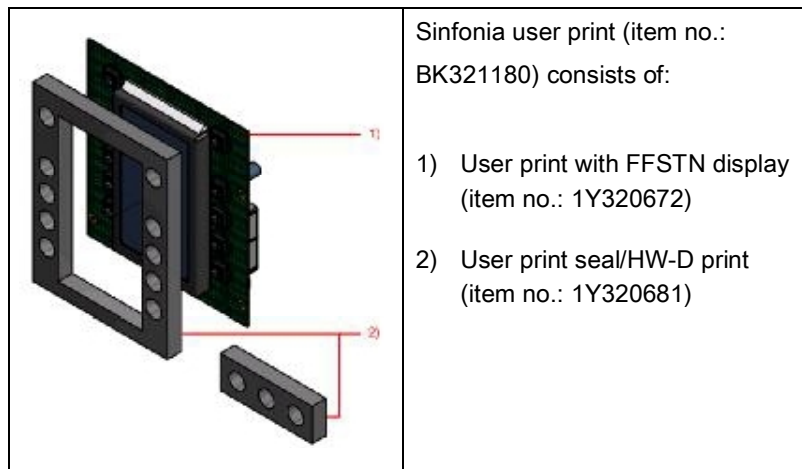

Sinfonia user print (item no.: BK321180) consists of:

- 1) User print with FFSTN display (item no.: 1Y320672)
- 2) User print seal/HW-D print (item no.: 1Y320681)

Fig. 1: Sinfonia user print (item no.: BK321180)

Note The "Sinfonia user print" (BK321180) module is only offered as a replacement part for the user print. The new color (previously: black, new: gray) is the distinctive feature for the "user print seal/HW-D print" (1Y320681).

Available documents	Document number	Document title	Document type
	None		

Author Yves Hionas
Technical Product Support

Release Michael von Däniken
Research & Development

FSA Pressure Switch Relocation Kit

1. Installation of Pressure Switch Relocation Kit

Materials: (List of parts in relocation kit number BK321029)

<u>Part</u>	<u>Description</u>	<u>Amount</u>	<u>Part Number</u>
1	Quick connect	1	1T310133
2	Bracket	1	1Y321028
3	Teflon tube (with connector attached)	180mm	1T310138

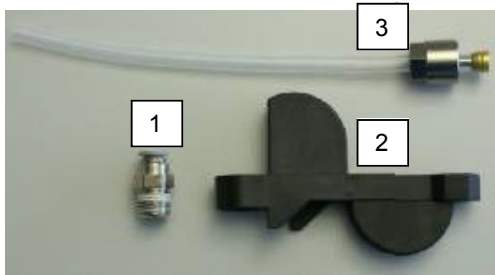

Tools: (Recommended tools for the installation)

<u>Description</u>	<u>Amount</u>	<u>Part Number</u>
T-20 Torx screw driver	1	
14mm open end wrench	1	
17mm open end wrench	1	
19mm open end wrench	1	
27mm open end wrench	1	
Hose pliers	1	BK311955

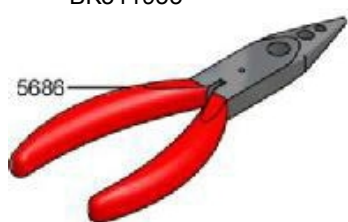

2. Preparation work

1. Depressurize / Empty coffee machine
 - a. Turn OFF water supply
 - b. With install card, enter "Install" menu > 4. Fluid System > Emptying > move cursor to "yes"
 - c. After 2.5 minutes, turn off coffee machine.
 - d. Unplug the coffee machine.
2. Remove the cup tray in the drip tray
3. Remove cup railing
4. Remove left side panel
5. Open grounds container door and remove grounds container
6. Open front panel assembly
7. Loosen the 2 T-20 screws and remove the front top panel

3. Pressure Switch – Removal Relocation Bracket – Installation

3a – CEME Switch

Attention!

If the pressure switch is the CEME brand switch (see picture below), you will need to replace it with the new TRAFAG brand pressure switch. If you have a Trafag switch installed, continue with step 3b (below).



1. Remove the rubber protective cap from the CEME pressure switch.
2. Unplug the two larger electrical connector from the pressure switch.
3. Remove the rubber protective cap from the wiring harness and discard.
4. Unscrew the pressure switch from the pressure block CEME = 17mm open end wrench
5. Clean out the threads of any Teflon tape remains.

3b – Trafag Switch

1. Unplug the two small electrical connector from the pressure switch.
2. Unscrew the pressure switch from the pressure block Trafag = 27mm open end wrench
3. Clean out the threads of any Teflon tape remains.

4. Relocation Bracket – Installation

1. Install the quick connector. For correct installation see the two pictures below.

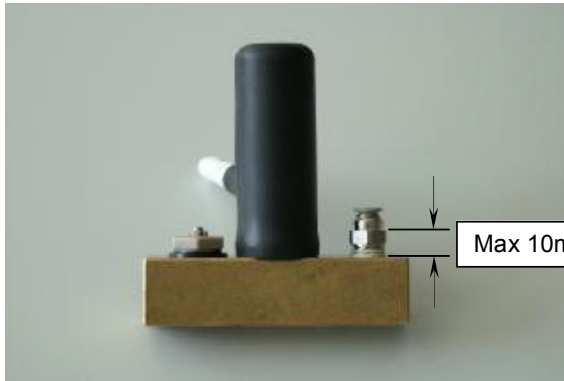

Install the quick connector using a 14mm open end wrench. The connector must be screwed in tightly to prevent leakage. Continue tightening until the distance between upper part of the hex nut and the pressure block is 10mm or less. The bracket must rest on the pressure block when installed correctly.

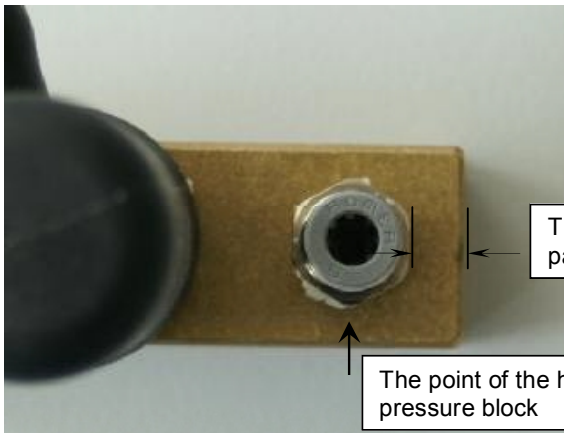

For the bracket to fit correctly, the hex nut on the quick connector must correspond to the picture. Ensure that the flat side of the hex nut is parallel to the end of the pressure block.

The flat side of the hex nut must run parallel to the end of the pressure block

The point of the hex nut must point forward on the pressure block

2. Remove the O-ring from the TRAFAG pressure switch and discard.



3. Install the TRAFAG pressure switch (27mm open end wrench) onto the new bracket. Use a 19mm open end wrench to counter hold the hex on the bracket
!! DO NOT USE THE BRACKET AS A WRENCH !!

4. Run the Teflon tube through the middle hole in the bracket. Do not kink the tube.



5. Install the bracket onto the pressure block.
6. Connect the Teflon tube to the quick connect using the hose pliers BK311955 to hold the tube while pressing it into the quick connector. You can also use a piece of emery cloth to grip the Teflon tube. Make sure that the tube is pushed into the quick release completely.

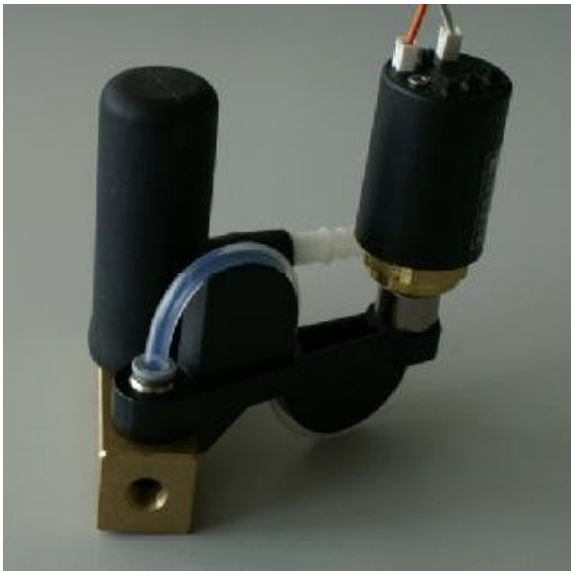

7. Connect the two small connector back to the TRAFAG pressure switch.
 - a. Pin 11 = white
 - b. Pin 12 = orange
8. Connect to the two larger connectors to the wiring harness connectors.
 - c. Orange to orange
 - d. White to white

5. Final Check – Machine Test

1. Close front panel
2. Turn ON water supply
3. Connect power supply – machine will be in ESM (Energy Save Mode)
4. Turn coffee machine ON – machine will initiate self test
5. Allow machine to heat up completely
6. Check pressure switch, Teflon tube and quick connect for possible leakage
7. Check pressure gauge for correct system pressure – 1.8bar

If all systems are functioning properly

1. Install left side panel
2. Install top front panel and tighten the two T-20 screws
3. Insert tablet chute
4. Close front panel



MEMO

Valued Service Partners

Franke Foodservice Systems Inc.
Franke Coffee Systems
800 Aviation Parkway
US-Smyrna, TN 37167
USA

Telephone +1 206 462 7215
www.franke-cs.com

From Ray Peden
Telephone (615) 462-4223
Fax (615) 462-4623
E-mail ray.peden@franke.com

4/13/2010

Pressure Block Troubleshooting and Repair

Dear Valued Service Partners and Associates,

The pressure block is a very critical assembly in the Sinfonia FSA. It controls the pressure in the steam boiler via a pressure switch, prevents vacuums from forming in the steam boiler via a vacuum breaker, vents steam during an over pressure event via a pressure relief valve and also has a dial indicator to show the technician if the boiler is operating at the correct pressure.

Recently, we have been experiencing above average failure rates as well as a concerning number of repeat failures. This memo will provide some important considerations when troubleshooting and repairing the pressure block components. I will also share some tips and tricks for dealing with known issues.

Normal Operating Conditions

During normal operation the Pressure Block's operating temperature should be warm to the touch, but not hot. If you cannot touch your finger to the brass block and leave it there, then there is a problem. Somewhere on the block there is a leak allowing hot steam to deliver thermal energy to the block. Over time, this heat will cause the internal components of the pressure switch to fail.

Abnormal Operating Conditions

A hot pressure block can be caused by a number of reasons. Each one is addressed below. A malfunctioning pressure block can effect drink fill levels and temperatures so an accurate diagnosis is critical to eliminate future problems. Keep in mind that fill levels and temperatures can also be effected by any number of problems such as clogged milk lines, milk pumps, etc. so these must be ruled out as well.

1. Leaking Vacuum Valve – Vacuum valves are prone to a small leak over time when hard water deposits accumulate on the valve preventing it from sealing completely. A new vacuum valve is being released in the EE kit made of PEEK material that is highly resistant to this build-up.
2. Leaking Overpressure Relief Valve – After an overpressure event, or multiple events, the overpressure relief valve can leak due to hard water deposits. This valve must be replaced if it is determined to be leaky.
3. The seal on fittings can become worn over time (or experience a gradual leak due to overtightening) which will cause a poor sealing surface. The fitting and/or supply tube must be replaced in this case.

4. Missing or torn o-rings.
5. Leaking Manometer Connection – After repeated replacements, the fitting connecting the manometer to the block can develop leaks. In this case, a new fitting is required. We now have a new manometer that has a metal faceplate and will not deform, thereby reducing wear and tear by eliminating the need to replace this part.

Please see the photo below for potential leak areas:

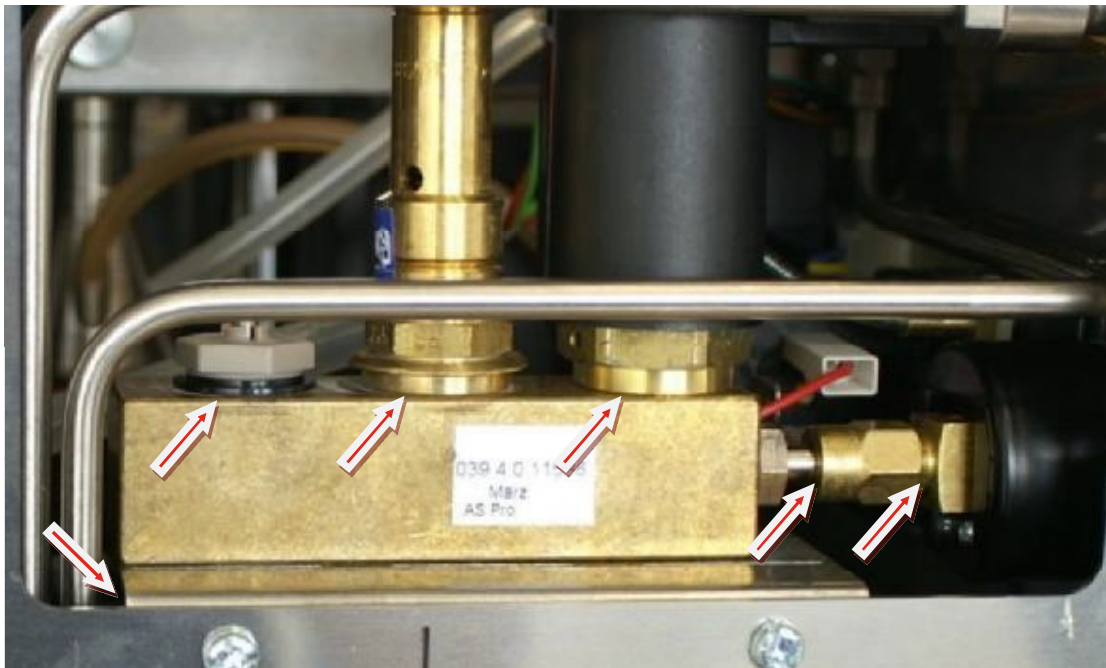

6. Overpressure Events – Overpressure events can be caused by many things. To make matters even more difficult, a hot block can cause overpressure situations itself, further clouding the picture! This can easily become a 'who came first, the chicken or the egg' example. It's easy to see that with the pressure switch directly mounted to the block, it will be subject to heat damage if something goes wrong. Some examples of common overpressure events are as follows:
 - a. Lack of water to the machine – If the coffee stick is disconnected or faulty, or any other situation exists that can cause the machine to be starved of water, the steam boiler can be drained down during drink production or cleaning. A half empty boiler and a massive heater = flash boiling of the water during heating and a rapid overpressure event.
 - b. Too little TDS This event is similar to oversteaming but can be differentiated by two factors:
 - i. The exhaust from the safety valve is a mixture of water and steam
 - ii. The water pump is running

- c. Scaled Autofill Probe – Hard water can scale the autofill probe so the machine cannot recognize the full boiler. This is virtual y the same as b above. Water/steam mixture and running pump. Another way to distinguish these from other oversteaming events is when water is discovered in the front panel, not just condensation.

Note: NivBoil readings can be observed in the Fluid system menu accessed by the install card. Readings should be less than 600 (less than 550 even better). If the reading is high, this indicates scale on the autofill probe or low TDS.

- d. Leaking pressure block See above!
- e. Sticking Relays – Heater relays are proven and reliable. The black carbon build-up is normal and expected. However, if they are not changed annually, they are subject to sticking closed and overpressurizing the boiler. This is easy to troubleshoot using the check outputs or by removing the leads to the pressure switch and seeing if the boiler stops heating and the pressure stops climbing.

Repair

Due to the large number of potential leak sites, a careful repair is crucial. It does little good to replace a pressure switch if the leaks are not addressed as the pressure switch is sure to fail again soon. We are working on a solution to mount the pressure switch away from the pressure block, but until this happens overpressure events that occur from site issues, etc. will continue to cause damage. All we can do is to make sure that the leaks and other issues within our control are addressed correctly.

- C.E.M.E pressure switches – If the machine is under warranty, please replace the old style CEME switch with a new Trafag switch.
- Ensure that there are no leaks and the block is only warm, not hot. **DO NOT LEAVE A REPAIR WITH A HOT BLOCK!!**
- Ensure that the rubber boot, P/N 310928 is over the safety valve is intact and in place. If after EE, there should be a sticker inside the panel below the block showing the correct routing of the exhaust tubing and mounting of the rubber boot. **DO NOT LEAVE A REPAIR WITHOUT A RUBBER BOOT IN PLACE OVER THE SAFETY VALVE!!**

⚠ WARNING

Risk of injury and damage to machine!

The protective cap on the overpressure valve prevents water from splashing the inside of the machine, potentially causing damage to the electronics.

- Make sure that the protective cap is placed correctly on the overpressure valve.

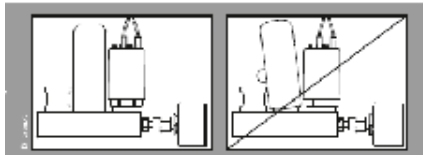

⚠ ADVERTENCIA

Riesgo de lesiones y daños a la máquina!

La tapa protectora de la válvula de sobrepresión impide que el agua salpique el interior de la máquina, que puede causar daños en la electrónica.

- Asegúrese de que el protector de seguridad está colocado correctamente en la válvula de sobrepresión.

- Vacuum Valve – The new PEEK valve must be installed correctly. The instructions can be found on CSS.

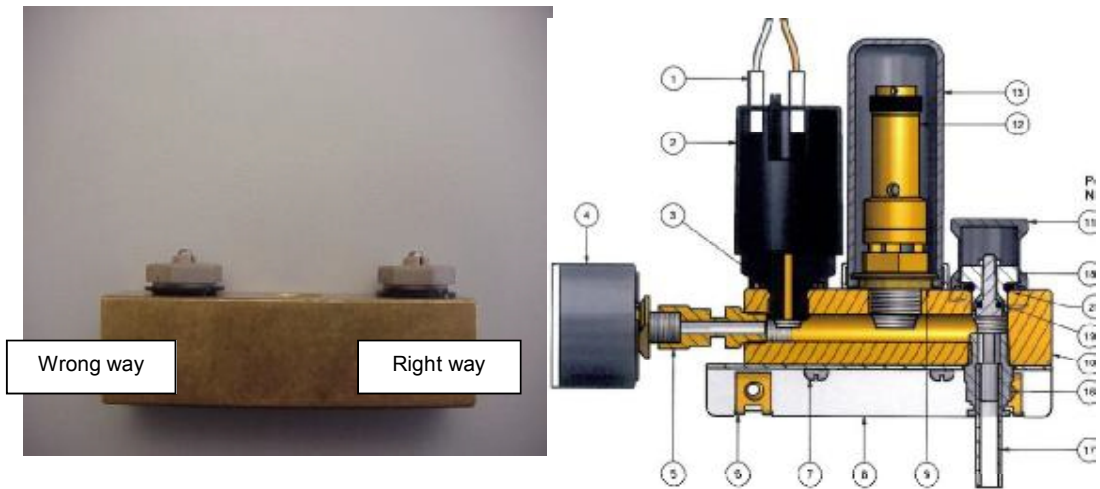

As always, address any questions or concerns to our Technical Services Department.

Kind regards,

Ray Peden
Director of Product Development NA

MEMO: CLARIFICATION OF PLACEMENT OF MUT

From Brian Culver
E-mail Brian.Culver@franke.com

06/17/2010

Dear Service Provider,

You should have received a communication about the proper placement of milk bags in the MUT yesterday. This memo is to provide clarification to the photo attached.

We are aware the placement of the MUT shown below is different from the work instructions you were previously given. A new work instruction is being created, and you will receive it shortly. The new placement of the MUT is to reduce breakage of the connections, provide better flow through the milk tubes, and is more appealing to our customers.

Moving forward, this is the correct way to install the MUT. You do not have to return to any locations to re-install, but please install the MUT and milk bags as shown in the photo below for your next appointments.

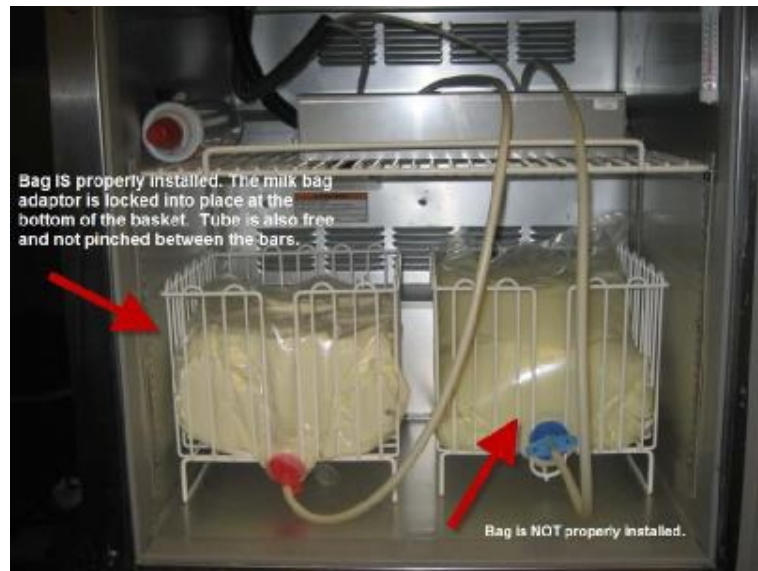

Please contact us with any questions.



**MEMO: ESPRESSO ENHANCEMENT (EE) INFORMATION:
INSTALLATION PROCEDURAL CHANGE REGARDING
NON-FAT MILK SENSOR**

From Brian Culver
E-mail Brian.Culver@franke.com

06/04/2010

Dear Service Provider,

This communication is regarding the NON-FAT milk sensor on the new MUT system. Please read the information below as it is important for proper installation of the MUT system and proceed with this change moving forward.

As stated in previous communication, the WHOLE and NON-FAT milk sensors are set to HIGH for sensitivity. Moving forward, you will need to change the dip switch for the NON-FAT milk sensor to LOW sensitivity. **Do not change the WHOLE milk sensor.** Switching the sensitivity to LOW should eliminate any "No Milk" error codes and any potential call backs related to the placement of the sensor. Please also remember to prime both milk types after changing the dip switch setting.

To restate, please change the dip switch for the NON-FAT milk sensor to LOW sensitivity.

Please contact us with any questions.

Kind regards,

Brian Culver

Water Condition Specifications

The standards for appropriate water condition specification are:

GPG = 1 – 5

PPM = 25 – 100

If the values indicate the water condition is within specification, **STOP** taking measurements and proceed with the PM appointment or reactive service call.

ADDITIONAL MEASUREMENTS (if necessary)

If values for **either** GPG or TDS are beyond specifications, take readings from two other locations in the store:

1. The **sample port** on the **RO system**
2. The **hand sink**

Sample Port on the RO System

1. Obtain a sample of water in a small **McDonald's cup** from the **sample port on the RO system**



2. Follow the instructions included in the **Mavea Test Kit** to measure the temporary hardness in grains per gall (**GPG**)
3. Using the same water sample, follow the instructions included with the **HM Digital TDS-3 meter** to measure the TDS of the water in parts per million (**PPM**)

Hand Sink

1. Obtain another sample of water in a small **McDonald's cup** from the **hand sink**



NOTE: Make sure the water sample is **COLD**. Allow the water to run for at least 30 seconds before obtaining a sample.

1. Follow the instructions included in the **Mavea Test Kit** to measure the temporary hardness in grains per gall (**GPG**)
2. Using the same water sample, follow the instructions included with the **HM Digital TDS-3 meter** to measure the TDS of the water in parts per million (**PPM**)
3. Record all data on the **Franke Equipment Service Work Order** form

TECHNICAL SUPPORT

For further assistance, please contact Technical Support at **800-310-5710**.

NEW COFFEE OUTLET

Sinfonia

Differences between the OLD and NEW coffee outlet:

- The old style coffee outlet is equipped with a microswitch to recognize the proper placement of the outlet on the machine. It is actuated by the tab on the coffee outlet.



- The **new** style coffee outlet has a plastic support piece that contains a magnet below the top part of the outlet. The magnet actuates a reed switch to let the unit know the outlet is in place.



NOTE: The support piece snaps right on the inside of the outlet. The magnet is under the tab.

Troubleshooting Steps:

1. VERIFY the serial number of the machine.

NOTE: Serial numbers starting from 00007016 have the new coffee outlet design; therefore, this should alert you that the coffee outlet has the magnet/reed switch system.

If the serial number is before 00007016, then **STOP** and continue with standard troubleshooting steps.

(If necessary)

If the serial number is 00007016 and above, then continue with the steps below.

2. Ask the caller to remove the coffee outlet and turn it upside down. You will need to have them check and see if the coffee outlet has the Magnet Support piece, as shown below:



NOTE: If the outlet does not have this piece, have the caller check the old outlet that was removed, around the espresso area, and the trash can. This piece should have been removed from the old outlet and attached to the new one.

Required Part Numbers:

Magnet and Support: 312079

Cable to Reed outlet switch: 320900

Reed sensor: 315034

Support reed contact: 312080

Kit: 320928 (includes all of the above)



MEMO

FCSNA Sales
FCSNA Tech Services
FCSNA ROMs

Franke Foodservice Systems Inc.
Franke Coffee Systems
800 Aviation Parkway
US-Smyrna, TN 37167
USA

Telephone +1 206 462 7215
www.franke-cs.com

From Ray Peden
Telephone (615) 462-4223
Fax (615) 462-4623
E-mail ray.peden@franke.com

9/20/2010

Effects Of Hard Water And Chemicals Like Chlorine On Boilers

Dear FCSNA Team,

I want to address the effects of hard and/or chlorinated water on the stainless steel coffee and steam boilers used in our coffee machines. Our coffee machines require all feed water to be properly treated prior to entering the machine. Properly treated as it relates to our coffee machines means:



1. The water must be safe to drink – potable water free of harmful organisms or toxins
2. The water must be between 3-5 gpg (grains per gallon) of temporary (carbonate) hardness*
3. The water must be free of the chlorine that is a common additive of municipal water systems

* This is our standard for water hardness. For specific customers, there may be different agreements in place that supersede this specification (i.e. McDonalds is 50-100ppm)

Why we require potable water is easy to understand, so I won't focus on that. Instead, I will detail the long term damaging effects of hard or chlorinated water and why their removal is so critical in preventing pitting and early failure often associated with stainless steel tanks. Following is the 'cliff notes' version.

Hard Water:

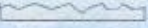
Water is commonly measured for Total Hardness (TDS- total dissolved solids). TDS is a combination of minerals that are 'permanent' and 'temporary', meaning that some of the minerals will come out of solution under heat and pressure to form lime scale and others will not. Because of this, we are only concerned with 'temporary' hardness. The effects of this scale build-up are many. Decreased efficiency of the heating elements (1/8" of scale = 26% reduction of efficiency), fouling of inlet and outlet connections to the boiler, failures of water/steam valves as well as clogging of small orifices throughout the water/steam delivery hydraulics. This scale build-up can be hard to diagnose and very costly to fix.

Thickness of limescale	Loss of efficiency
1/16" 	12%
1/8" 	26%
1/4" 	40%

Chlorine:

Chlorine is an oxidizing molecule that stimulates the corrosion of some metals and alloys. The degree of corrosion is also greater in higher alkaline environments. Chlorine under heat and pressure, when in a boiler full of water, produces hydrochloride gas which is then absorbed back into the water, resulting in hydrochloric acid. Hydrochloric acid along with the additional leftover chlorine both act negatively to the stainless steel boiler.

Stress-corrosion cracking, leaking welds and other degradation is the result of the chlorine and chlorine by-products. Here are some pictures that show this damage:



Summary:

Water filtration is KEY. Even in areas where water is between 3.5 gpg, rest assured that the local municipality has injected enough chlorine to cause significant damage to the boilers. In less than 6 months, the unfiltered water can eat a hole in the boiler, requiring a new boiler and causing damage to other areas of the machine. This memo is meant as an education piece to better equip you all to fully address these issues as they inevitably come up in the field. I am here to address specific cases or to answer additional questions if needed.

Kind regards,

Ray Peden
Director of Product Development NA