

USE 75°C WIRE FOR AMPACITY DETERMINATION
 CRANKCASE HEATER(S) WHEN PROVIDED, MUST BE CONNECTED TO TERMINALS "L1" & "L2" ON CONTACTOR.

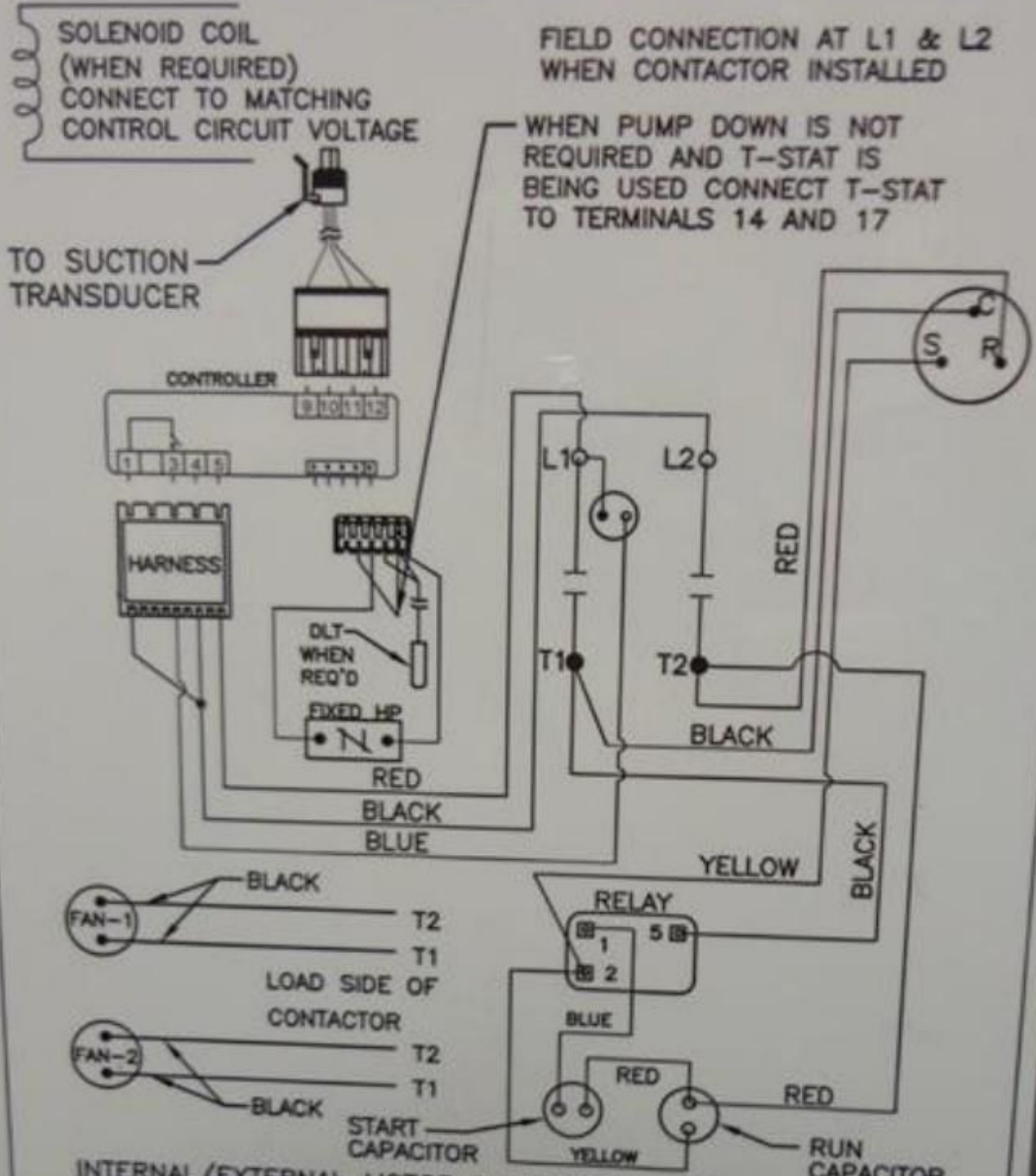

INTERNAL/EXTERNAL MOTOR PROTECTION PROVIDED - ALLOW TIME FOR RESET.
 USE THIS EQUIPMENT ON A GROUNDED SYSTEM ONLY.
 USE COPPER CONDUCTORS ONLY.

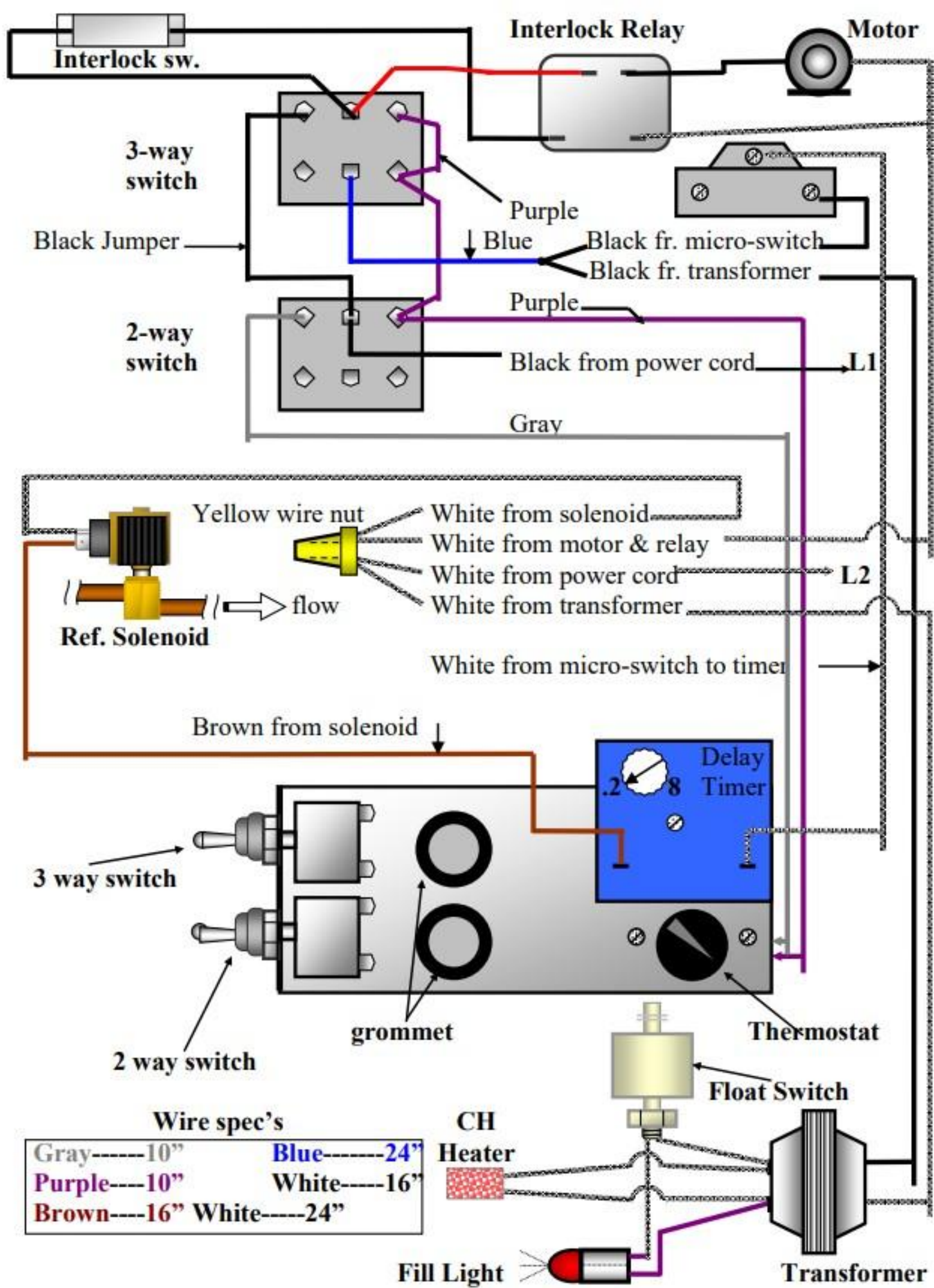

Wire spec's

Gray-----10"	Blue-----24"
Purple-----10"	White-----16"
Brown-----16"	White-----24"

