

INSTALLATION PROCEDURES  
FOR  
REMOTE CONDENSER SYSTEMS

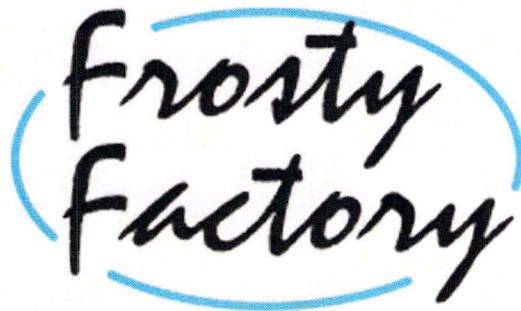

FROSTY FACTORY OF AMERICA, INC.

1-800-544-4071

Contacts: Ralph Pettijohn or Mark Owens

Revised 02-21-2012

Installation responsibility

(Typical)

Customer is to furnish:

1. \_\_\_\_\_(Quantity) dispensing units (evaporators).
2. \_\_\_\_\_(Quantity) condensing units (with sight glass & filter/drier).
3. (1) 5/8" & (1) 3/8" Self-Sealing, Quick Disconnect Refrigerant Coupling included with each dispenser from factory.
4. (1) 5/8" and (1) 3/8" (assembled) copper manifold included with each condenser from factory. (Multiple set-ups only)

Contractor will furnish:

1. Permits.
2. Condenser platform for each condensing unit as per customer and /or local code specifications.
3. Electrical service for each condensing unit corresponding with the requirements specified on the data plate.
4. 7/8" and 3/8" soft copper lines from the condensing units to the manifolds.
5. 7/8" soft copper oil traps. (One per each 10ft. vertical run).
6. 5/8" and 3/8" soft copper loop from the manifold to the quick Disconnect fittings.
7. Suction line insulation (7/8"ID X 1/2" wall). Plus 5/8" on manifold & loop.
8. R404a or R507a refrigerant. (Average amount per condensing unit is 5 to 10 lbs.)
9. Clamps (pipe hangers) Unistrut, fittings and/or other devices necessary to support refrigerant lines.
- 10. Installers: To assemble, solder (Using Quick Connect Fittings provided) leak test and evacuate service lines as required. Installers will also Connect assembled lines to dispensers and test run system (with \*product in the dispenser.) Set final refrigeration charge and product consistency, according to the factory Installation Guide and Service Manual.**
11. Warranty on all Contractors supplied materials and labor as per customer requirements.

Note: Contractor will become familiar with and read all Notes and Cautions in the Installation Guide and refer technical questions to:

Ralph Pettijohn or Mark Owens @:

Frosty Factory of America Inc. 1 (800) 544-4071

\* If product is not available use 5 lbs. sugar dissolved into 4 gallons water as a test mix.

**INSTALLATION GUIDE  
FOR  
REMOTE CONDENSER SYSTEMS**

**DISPENSING UNITS**

- Step 1.** Make sure that the selected location is adequate to support the 225lb.weight of the unit plus the weight of the product in the hopper and cylinder. **At least 6” clearance must be provided behind the units to allow space for quick disconnect fittings and manifolds.**
- Step 2.** Check the unit **data plate** on the rear panel of the machine and be sure that the power supply in the building corresponds with the electrical rating of the unit.
- Step 3.** After placing the unit at the selected location, the dispenser can be **leveled** by turning the lower portion of the legs. The unit should be level front to back as well as left to right.
- Note:** **Dispensing units are shipped from Frosty Factory with an R404 pre-charge.** The installer is encouraged to construct, leak check and pre charge the refrigerant lines before connecting the lines to the dispensers. (The “Quick Connect” fittings will not leak while they are being connected.)
- Step 4.** Attach the refrigerant lines (with Quick Connect fittings) to the rear of the cabinet utilizing the factory manifold. (See attached drawings to view typical installations)

**CONDENSING UNITS**

- Step 1.** Check the selected location, and the local roof mounting codes, for the unit, to insure that racks, braces, flooring foundation, etc. are adequate to support the weight of the unit
- Step 2.** Check the unit data plate to be sure that the electrical rating of the unit corresponds with the power supply of the building.
- Step 3.** Place the condensing unit in the selected position.
- Note:** The use of a suction line filter, **liquid line filter** and **moisture indicator** (Sight glass) is required on all Frosty Factory installations.
- Step 4.** Fabricate and install the liquid and suction lines. When sweat connections are made be sure that copper filings and debris are carefully removed from the tubing before final installation. Do not allow the liquid and suction lines to be opened to the atmosphere longer than 15 minutes.  
**Caution:** Condensing units shipped from Frosty Factory are charged with Nitrogen, which **must be evacuated before charging with refrigerant.**
- Step 5.** Purge the dry air charge from the unit by opening the liquid line outlet fitting for your particular unit. Connect the suction and liquid lines to the unit.
- Step 6.** Pressurize and "leak check" the entire system with an appropriate refrigerant or Nitrogen. Correct any leaks found. Connect a vacuum pump to both the low and high side valves (if provided) and draw a deep vacuum. **DO NOT USE THE MOTOR-COMPRESSOR TO PULL A VACUUM AND DO NOT OPERATE THE MOTOR-COMPRESSOR IN A VACUUM).**
- Step 7.** Break the vacuum with refrigerant and re-evacuate the system. When complete add sufficient R404 (HP62) or R507 (AZ50) refrigerant to bring the pre-charge pressure to approximately 75psi.

**Caution:** Non Azeotropes such as R404 must be charged in the liquid phase only. To avoid compressor damage, liquid must always be charged into the high side or into an accumulator. When charging through the suction side, the refrigerant should always be charged in vapor form. **DO NOT OVERCHARGE THE SYSTEM.** Flood-back can cause severe damage to the compressor.

**Step 8.** Make all electrical connections in accordance with national and local electrical codes. Check to confirm that the **time delay** in the condenser unit is set to approximately **2 minutes**. Determine that the pressure switch has been set to **Cut-in at 35 psi and cutout at 10 psi**.

**Note: Cutout equals Cut-in minus the differential.** Example: with the pressure switches set at 35 psi and 25 psi respectively, the condenser will cut in at 35 psi and cut out at 10 psi. (Some units do NOT use the differential method)

**START-UP (See Dispensing Unit Start-up procedures on page 5.)**

**Note:** The dispensers **must have product** in them prior to start-up in order to establish correct operating pressures. **NEVER** use pure water to test freeze the dispensers. If necessary use a mixture of **5 lbs. sugar and 4 gallons water to prepare an acceptable test mix.**

- Step 1.** When setting initial pressures on remote systems, it is recommended that you operate one dispenser, (only *one side* if dispenser is dual) until initial pressure is set. With suitable mix in the hopper continue to next step.
- Step 2.** On the dispensing unit being charged, turn both switches to the right (snowflake) position. The liquid line solenoid valve will open within 15 seconds. As refrigerant begins to flow through the **dispensing unit** the pressure switch in the **condensing unit** will activate. The condensing unit will start after approximately 2 minutes.
- Step 3.** Begin adding refrigerant immediately after the condenser starts to prevent the condensing pressure from dropping below the 10-psi shut off point. Once ice crystals are visible through the dispenser faceplate, your suction pressure should be set at or slightly above **20 psi**. The sight glass should be clear. The liquid line pressure should be around **250 to 300psi**. depending on outside air temperature. Fill the remaining dispensers with product. Turn both switches to the right (Snowflake) position. When ice crystals are visible check the pressures as described in step 4.
- Step 4.** With pressures set as described, check the low side pressures as follows:  
With **3 evaporators** active the low side pressure should be approx. **40 to 50 psi**;  
With **2 evaporators** active the low side pressure should be approx. **30 to 40 psi**;  
With **1 evaporator** active the low side pressure should be approx. **20 to 25 psi**.
- Step 5.** Allow the entire system to remain OFF for at least 45 minutes. Turn all dispensers ON and re-check the sight glass. Top off until sight glass is clear, as required.

The installation is complete. If applicable, install weather cover on the condensing unit.

## DISPENSING UNIT START-UP

### MACHINE PREPARATION

NOTE: *The space around the machine must be clear at all times for proper airflow!*

1. Plug the electrical cord into a dedicated wall outlet. (Do not allow anything else to be plugged into the same receptacle as the dispensing unit.)
2. If unit has auto-fill option, either connect the mix supply hoses or install the gray plug into the auto-fill fitting at the back of the unit to prevent mix loss. (**Without the gray plug installed or the mix supply hose connected, the entire contents of the hopper will gravity drain onto the floor as soon as the unit is turned ON!**)
3. The machine and parts can now be cleaned and assembled according to the cleaning procedures in section 4 of the manual.

Including;

- A. Install Spring Seal onto the beater bar according to the instructions on the lid.
- B. Insert the Beater bar into the cylinder. While inserting the beater bar, Rotate the beater bar left and right until it is fully engaged into the drive system.
- C. Apply a light film of lubricant on the faceplate O-ring (Round rubber gasket) and press it into the faceplate groove.
- D. Install the Faceplate.
- E. Install Drip tray.

### START-UP

1. Fill hopper with product. (Or a **test mix of 5 pounds of sugar to 4 gallons of water.**)
2. After the freezing chamber is completely full and “bubbling” has stopped, turn both switches to the right (Snowflake position).
3. Product will freeze in 15 to 30 minutes depending on mix temperature, room temperature and outside air temperature.
4. If mix thickness is not satisfactory, turn the TCC screw clockwise for a thicker beverage or counter clockwise for a thinner beverage. Usually about 2 full turns of the TCC screw is sufficient to correct the mix thickness.
5. Refer to operator’s manual for more detailed instructions if needed.

Accessory List  
Remote Models

1. Drip tray
2. Manual
3. Faceplate
4. "Goody Bag"
5. Beater Bar
6. Hopper Cover
7. Drip Tube Brush
8. Quick Disconnect Fittings

\*4 "Goody" Bag" includes:

- Faceplate knobs (4)
- Faucet brush
- Petrol Gel
- Sanitizing packet
- Spare faucet o-rings (2)
- Warranty card

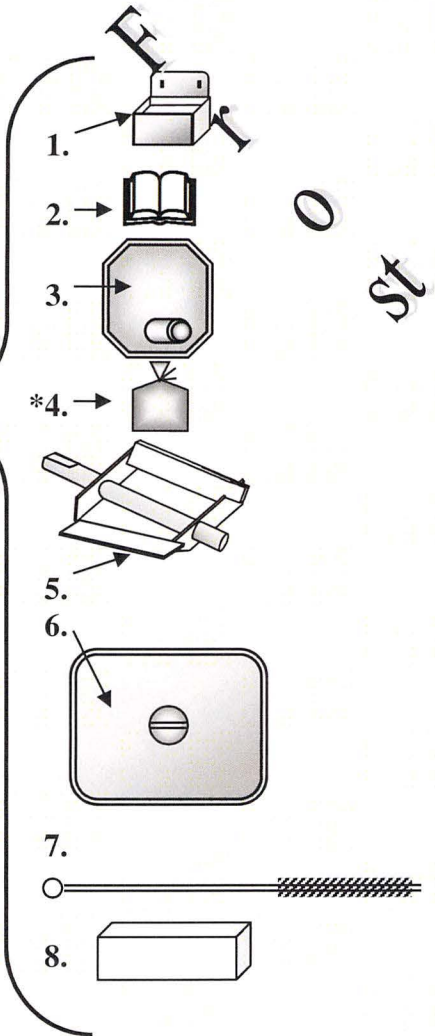
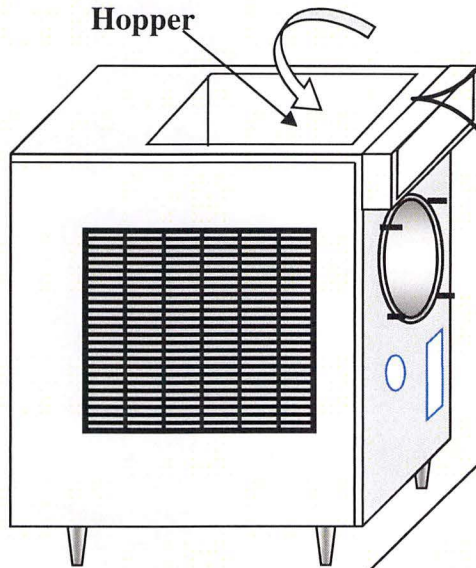

## REFRIGERATION CONNECTIONS-REMOTE

The suction line is 7/8" copper from the condenser to the manifold, and 5/8" copper from the manifold to the dispensers. The pressure line is not shown in the following drawing because it has the **same configuration** as the suction line: Except that **the pressure line is 3/8" copper from the condenser to the manifold** and from the manifold to the dispenser. A "P" trap is required in the pressure line when the vertical drop is greater than 10ft.

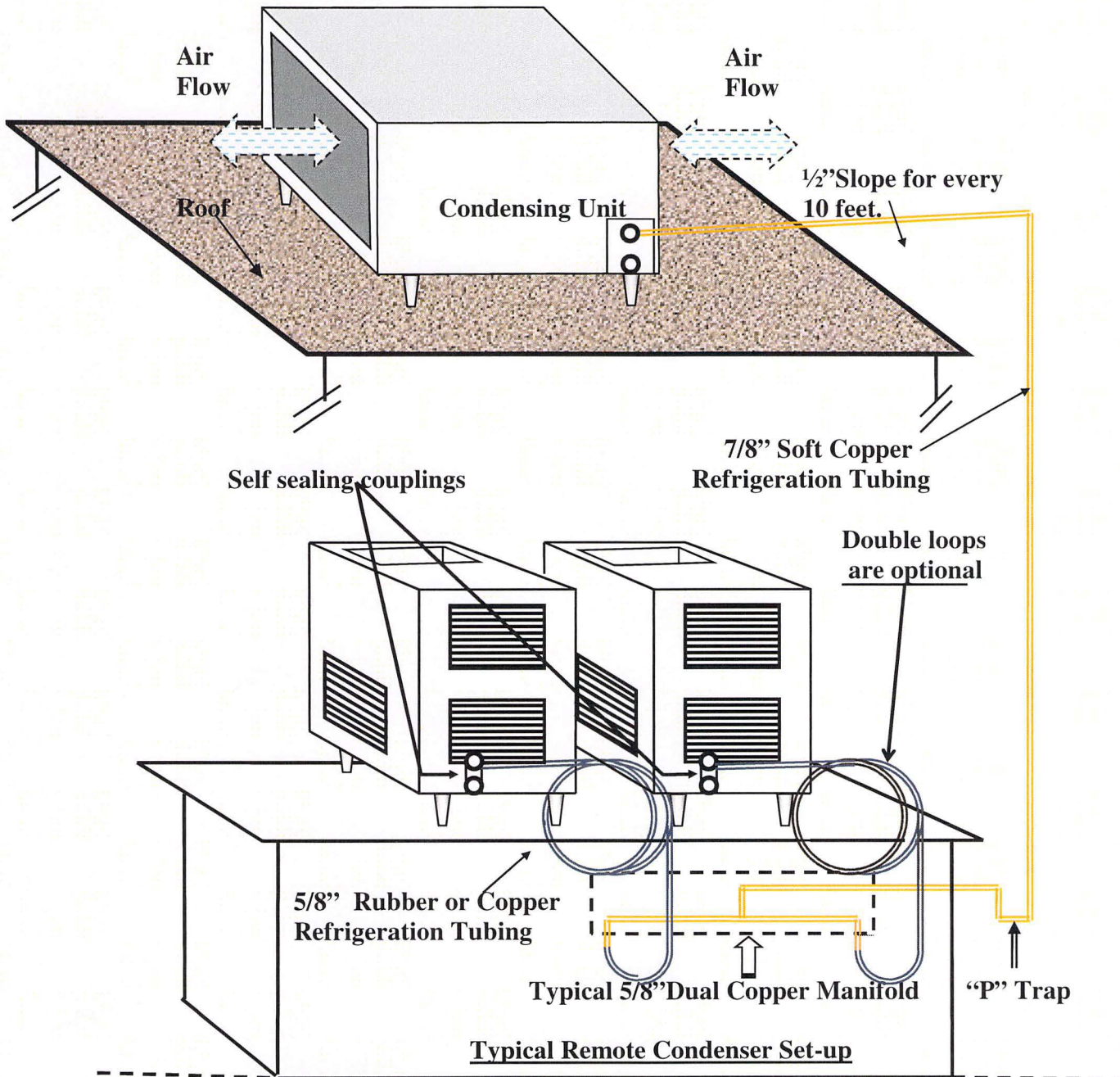

**Aeroquip 5500**  
**Self Sealing Couplings**

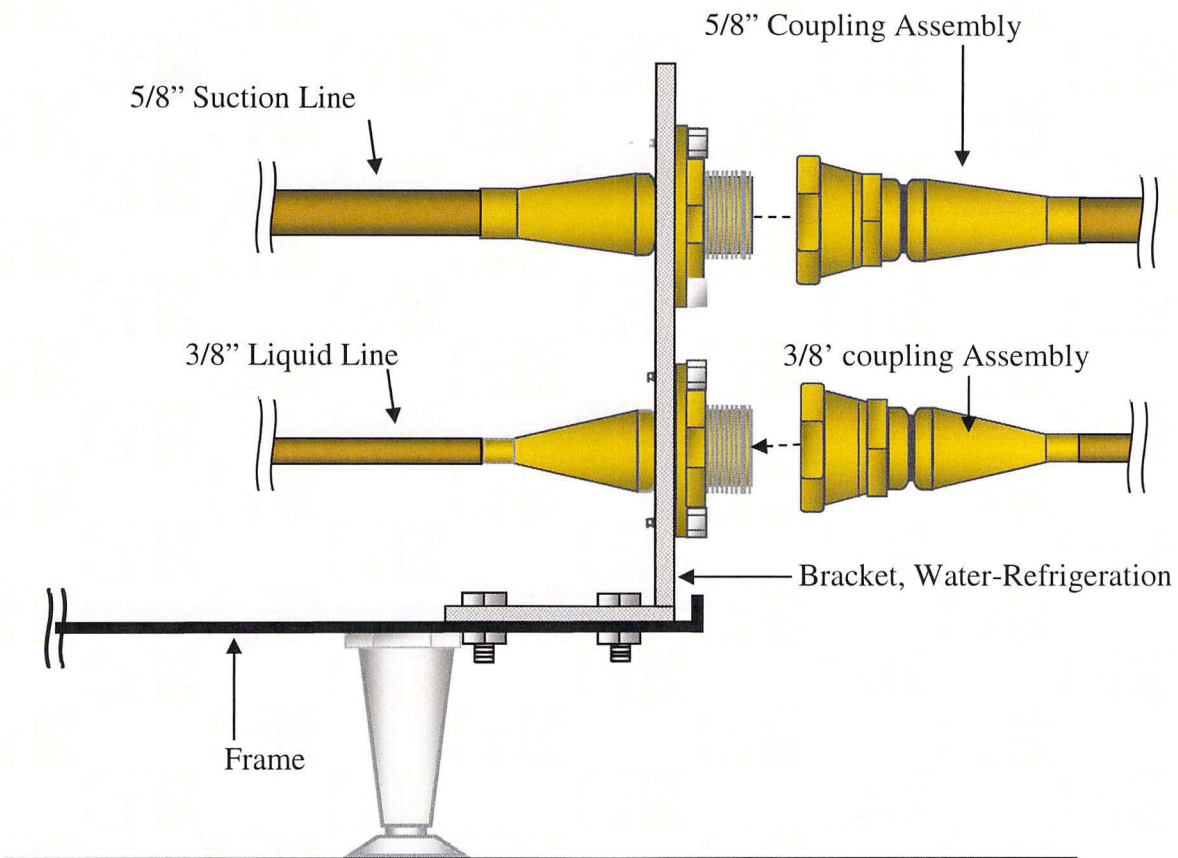

**NOTE:** The assemblies include male and female halves as well as the hold-down washer. The male half is pre-assembled within the dispenser cabinet.

1. Both "female halves" can be soldered onto the main copper lines from the manifold prior to being vacuumed, leak checked and pre-charged.
2. After the service lines are assembled, the "self sealing" couplings can be connected to the dispensers without loss of refrigerant. **Both halves are "self sealing"** and will NOT leak when dis-assembled.

**NOTE:** Use **thread protectors** on male ends until ready to assemble. Any damage to threads will create a leak hazard.

<p>SECTION 7 SPARE PARTS LIST</p>
---------------------------------------

Revised 08/06/07

**7.1 SPARE PARTS FROZEN DRINK MACHINE MODELS 115R**

<u>DESCRIPTION</u>	<u>ITEM NUMBER</u>
Ballast (115v)	F0269
Ballast (220v)	F0536
Bearing Plate	C2306
Bearing, Motor (Obsolete)	F0474
Bearing, Motor	F0738
Beater Bar Assembly, Lg.	C6527
Beater Bar Frame, Lg.	C6509
Beater Bar Spring Seal	F0355
Block, Spacer Lg.	C2308
Brush, Drip Tube, Lg.	F0327
Bulb, 12" Light	F0539
Clip Ring, Lg.	F0330
Clip Ring, Sm.	F0331
Coil, Ref. Solenoid 120Volt	F2526
Coil, Ref. Solenoid 230Volt	F1526
Computer Board, Auto Fill 110Volt	F0577
Computer Board, Auto Fill 220Volt	F0562
Coupling, Assembly 3/8"Ref.	F0913
Coupling, Assembly 5/8"Ref.	F0914
Coupling, Half 3/8"Female	F0912
Coupling, Half 5/8"Female	F0911
Drip Tray	F0195
Drip Tray Insert	F0196
Drip Tray Screws	F0905
Drip Tube Brush	F0327
Drive Belt	F0473
Drive Motor	F732
Drive Motor Assembly	C732
Drive Motor Pulley	F0471
Drive Plate	C4403
Dryer, Liquid Line 5Cu"	F5543
Face Plate with magnet	C6501
Face Plate Bushing	C6522
Face Place Interlock Relay Coil	F0383
Face Plate Knobs	F0262
Faucet Assembly	C6513
Faucet Body	C6513B
Faucet Brush	F0326
Faucet Nut	F0197
Faucet Plunger	C6513P
Faucet Spring	F0564
Fill Light	F0207
Float Clip	F0812

<u>DESCRIPTION</u>	<u>ITEM NUMBER</u>
<b>Flywheel</b>	<b>F6525</b>
<b>Flywheel Bearing</b>	<b>F0267</b>
<b>Heat Sequencer</b>	<b>F0400</b>
<b>High Pressure Switch</b>	<b>F0660</b>
<b>Hopper Cover</b>	<b>F0497</b>
<b>Legs, 4" Stainless</b>	<b>F0800</b>
<b>Microswitch</b>	<b>F0346</b>
<b>Motor Spring Bracket</b>	<b>F1239</b>
<b>Motor Stop Bracket</b>	<b>F1203</b>
<b>O-Ring, Face Plate</b>	<b>F0374</b>
<b>O-Ring, Faucet</b>	<b>F0491</b>
<b>O-Ring, Fill Switch</b>	<b>F0161</b>
<b>Panel Louver</b>	<b>F0254</b>
<b>Panel, Left Side</b>	<b>F6405</b>
<b>Panel, Rear</b>	<b>F6407</b>
<b>Panel, Right Side</b>	<b>F6406</b>
<b>Petro-Gel</b>	<b>F0298</b>
<b>Puller tool (Ceramic ring)</b>	<b>F0012</b>
<b>Pulley, Drive Motor</b>	<b>F0471</b>
<b>Rear Cylinder Brace</b>	<b>F2005</b>
<b>Sanitizer</b>	<b>F0492</b>
<b>Scraper Blade</b>	<b>C6510F</b>
<b>Scraper Blade Spring</b>	<b>F6512</b>
<b>Seal, Ceramic</b>	<b>F0665</b>
<b>Sign Panel</b>	<b>F0170</b>
<b>Stainless Steel Legs</b>	<b>F0800</b>
<b>Starter Base</b>	<b>F0538</b>
<b>Starter, Light</b>	<b>F1009</b>
<b>Switch Nut</b>	<b>F7003</b>
<b>Switch, 2-Position, Bottom</b>	<b>F0417</b>
<b>Switch, 3-Position, Top</b>	<b>F0416</b>
<b>Switch, Fill Light (Float)</b>	<b>F0811</b>
<b>Tension Spring</b>	<b>F0469</b>
<b>Thermostat</b>	<b>F0401</b>
<b>Time Delay (Adjustable)</b>	<b>F4998</b>
<b>Transformer (Multi-volt)</b>	<b>F4995</b>
<b>Valve, Expansion, 3 Gal.</b>	<b>F0529</b>
<b>Valve, Solenoid, 3/8" Ref.</b>	<b>F0526</b>

<p>SECTION 7 SPARE PARTS LIST</p>
---------------------------------------

Revised 08/03/07

**SPARE PARTS FROZEN DRINK MACHINE MODELS (215R)**

<u>DESCRIPTION</u>	<u>ITEM NUMBER</u>
Ballast (115v)	F0269
Ballast (220v)	F0536
Bearing Plate	C2306
Bearing, Motor	F0738
Beater Bar Assembly, Long.	C6530
Beater Bar Frame New Style	C6528
Beater Bar Spring Seal	F0355
Block, Spacer Remote	C2316
Brush, Drip Tube, Sm.	F6526
Bulb, 9" Light	F1237
Clip Ring, Lg.	F0330
Clip Ring, Sm.	F0331
Coil, Ref. Solenoid 120Volt	F2526
Coil, Ref. Solenoid 230Volt	F1526
Computer Board, Auto Fill 110Volt	F0577
Computer Board, Auto Fill 220Volt	F0562
Coupling, Assembly 3/8"Ref.	F0913
Coupling, Assembly 5/8"Ref.	F0914
Coupling, Half 3/8"Female	F0912
Coupling, Half 5/8"Female	F0911
Drain Tube 3/8" Plastic	F0426
Drip Tray	F6603
Drip Tray Insert	F6604
Drip Tray Screws	F0905
Drive Belt	F0473
Drive Motor	F732
Drive Motor Assembly	C732
Drive Motor Pulley	F0471
Drive Plate	C4403
Dryer, Liquid Line 5Cu"	F5543
Face Plate with magnet	C6521
Face Plate Bushing (shouldered)	C6522
Face Plate Knobs	F0262
Faucet Assembly	C6513
Faucet Body	C6513B
Faucet Brush	F0326
Faucet Nut	F0197
Faucet Plunger	C6513P
Faucet Spring	F0564
Fill Light	F0207
Float Clip	F0812
Flywheel	F6524

<u>DESCRIPTION</u>	<u>ITEM NUMBER</u>
Flywheel Bearing	F0267
Hopper Cover sm.	F0498
Legs, 4" Stainless	F0800
Microswitch	F0346
Motor Spring Bracket	F4202A
Motor Stop Bracket	F1203
O-Ring, Face Plate sm	F0357
O-Ring, Faucet	F0491
O-Ring, Fill Switch	F0161
Panel, Left Side	F6436
Panel, Rear	F2006
Panel, Right Side	F6437
Petro-Gel	F0298
Puller tool (Ceramic ring)	F0012
Sanitizer	F0492
Scraper Blade	C6510
Scraper Blade Spring	F6517
Seal, Ceramic	F0665
Starter Base	F0538
Sign Panel	F0316
Spring, Tension Lg.	F0469
Starter, Light	F1009
Switch Nut	F7003
Switch, 2-Position, Bottom	F0417
Switch, 3-Position, Top	F0416
Switch, Fill Light (Float)	F0811
Thermostat	F0401
Time Delay (Adjustable)	F4998
Transformer (Multi-volt)	F4995
Valve, Expansion, 2 Gal.	F0530
Valve, Solenoid, 3/8" Ref.	F0526

<p>SECTION 7 SPARE PARTS LIST</p>
---------------------------------------

Revised 08/06/07

**7.1 SPARE PARTS FROZEN DRINK MACHINE MODELS 235R**

<u>DESCRIPTION</u>	<u>ITEM NUMBER</u>
Ballast (115v)	F0269
Ballast (220v)	F0536
Bearing Plate	C2306
Bearing, Motor (Obsolete)	F0474
Bearing, Motor	F0738
Beater Bar Assembly, Lg.	C6527
Beater Bar Frame, Lg.	C6509
Beater Bar Spring Seal	F0355
Block, Spacer Lg.	C2308
Brush, Drip Tube, Lg.	F0327
Bulb, 12" Light	F0539
Clip Ring, Lg.	F0330
Clip Ring, Sm.	F0331
Coil, Ref. Solenoid 120Volt	F2526
Coil, Ref. Solenoid 230Volt	F1526
Computer Board, Auto Fill 110Volt	F0577
Computer Board, Auto Fill 220Volt	F0562
Coupling, Assembly 3/8"Ref.	F0913
Coupling, Assembly 5/8"Ref.	F0914
Coupling, Half 3/8"Female	F0912
Coupling, Half 5/8"Female	F0911
Drip Tray	F0195
Drip Tray Insert	F0196
Drip Tray Screws	F0905
Drip Tube Brush	F0327
Drive Belt	F0473
Drive Motor	F732
Drive Motor Assembly	C732
Drive Motor Pulley	F0471
Drive Plate	C4403
Dryer, Liquid Line 5Cu"	F5543
Face Plate with magnet	C6501
Face Plate Bushing	C6522
Face Place Interlock Relay Coil	F0383
Face Plate Knobs	F0262
Faucet Assembly	C6513
Faucet Body	C6513B
Faucet Brush	F0326
Faucet Nut	F0197
Faucet Plunger	C6513P
Faucet Spring	F0564
Fill Light	F0207
Float Clip	F0812

<u>DESCRIPTION</u>	<u>ITEM NUMBER</u>
<b>Flywheel</b>	<b>F6525</b>
<b>Flywheel Bearing</b>	<b>F0267</b>
<b>Heat Sequencer</b>	<b>F0400</b>
<b>High Pressure Switch</b>	<b>F0660</b>
<b>Hopper Cover</b>	<b>F0497</b>
<b>Legs, 4" Stainless</b>	<b>F0800</b>
<b>Microswitch</b>	<b>F0346</b>
<b>Motor Spring Bracket</b>	<b>F1239</b>
<b>Motor Stop Bracket</b>	<b>F1203</b>
<b>O-Ring, Face Plate</b>	<b>F0374</b>
<b>O-Ring, Faucet</b>	<b>F0491</b>
<b>O-Ring, Fill Switch</b>	<b>F0161</b>
<b>Panel Louver</b>	<b>F0254</b>
<b>Panel, Left Side</b>	<b>F6405</b>
<b>Panel, Rear</b>	<b>F6407</b>
<b>Panel, Right Side</b>	<b>F6406</b>
<b>Petro-Gel</b>	<b>F0298</b>
<b>Puller tool (Ceramic ring)</b>	<b>F0012</b>
<b>Pulley, Drive Motor</b>	<b>F0471</b>
<b>Rear Cylinder Brace</b>	<b>F2005</b>
<b>Sanitizer</b>	<b>F0492</b>
<b>Scraper Blade</b>	<b>C6510F</b>
<b>Scraper Blade Spring</b>	<b>F6512</b>
<b>Seal, Ceramic</b>	<b>F0665</b>
<b>Sign Panel</b>	<b>F0170</b>
<b>Stainless Steel Legs</b>	<b>F0800</b>
<b>Starter Base</b>	<b>F0538</b>
<b>Starter, Light</b>	<b>F1009</b>
<b>Switch Nut</b>	<b>F7003</b>
<b>Switch, 2-Position, Bottom</b>	<b>F0417</b>
<b>Switch, 3-Position, Top</b>	<b>F0416</b>
<b>Switch, Fill Light (Float)</b>	<b>F0811</b>
<b>Tension Spring</b>	<b>F0469</b>
<b>Thermostat</b>	<b>F0401</b>
<b>Time Delay (Adjustable)</b>	<b>F4998</b>
<b>Transformer (Multi-volt)</b>	<b>F4995</b>
<b>Valve, Expansion, 3 Gal.</b>	<b>F0529</b>
<b>Valve, Solenoid, 3/8" Ref.</b>	<b>F0526</b>

## OPERATION

These cross sectional views of the Aeroquip 5500 Series refrigerant self-sealing coupling illustrate

the connecting and sealing operation of the coupling halves and their valve assemblies.

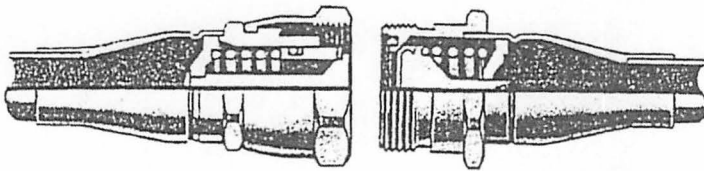

Figure 1  
Coupling Halves Disconnected

### Coupling Halves Disconnected

Coupling halves are disconnected, yet each maintains a perfect seal against refrigerant loss or inclusion of foreign matter. The coupling body ends are formed to permit brazing of standard tubing as required. This assures a leakproof tubing-coupling joint. Spring in 5502 bulkhead half (right unit) presses the poppet against the sealing surface inside the body. In the 5505 tubing half (left unit), the spring actuates a sleeve which seals behind the stem valve face.

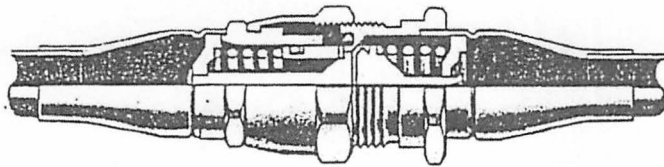

Figure 2  
Coupling Halves Partially Connected

### Coupling Halves Partially Connected

During connection, the body on the 5502 bulkhead half contacts the synthetic seal on the sleeve of the 5505 tubing half. The stem valve head contacts the face of the poppet valve expelling all air. Note that each coupling half is still completely sealed, preventing leakage of refrigerant.

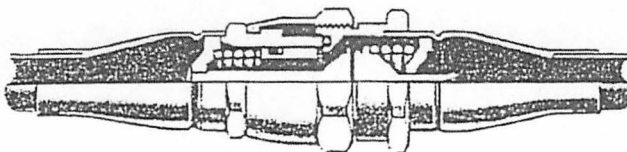

Figure 3  
Coupling Halves Connected

### Coupling Halves Connected

Tightening the union nut draws the coupling halves together, moving the poppet valve and the sleeve to open the fluid passage. When fully coupled, a knife edge metal final seal forms a leakproof joint between the two coupling halves.

8	7	6	5	4	3	2	1
UNIT_MODEL_NUMBER	PUMPDOWN_CAPACITY	ACCUMULATOR_CAPACITY	COMPRESSOR_MODEL_NO				SPECIFICATIONS
FJAM-A252-CFV-076	R404A 17.2 LBS	R404A 6.9 LBS	ZB19KCE-PFV				ES NO. DESCRIPTION
							ES22-122 PACKAGING
							ES81-159 CLEANLINESS
							ES81-250 IDENTIFICATION
							ES92-167 REGULATORY COMPLIANCE

ES NO.	DESCRIPTION
ES22-122	PACKAGING
ES81-159	CLEANLINESS
ES81-250	IDENTIFICATION
ES92-167	REGULATORY COMPLIANCE

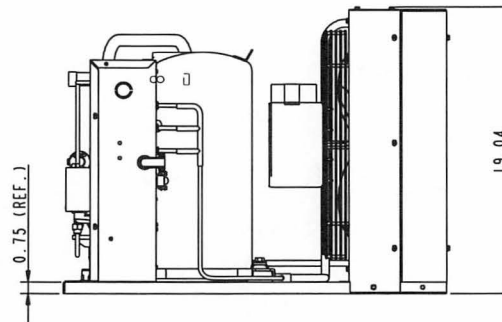
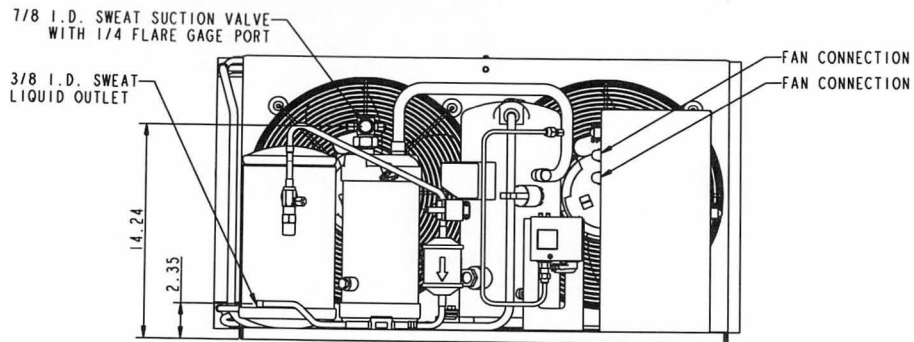
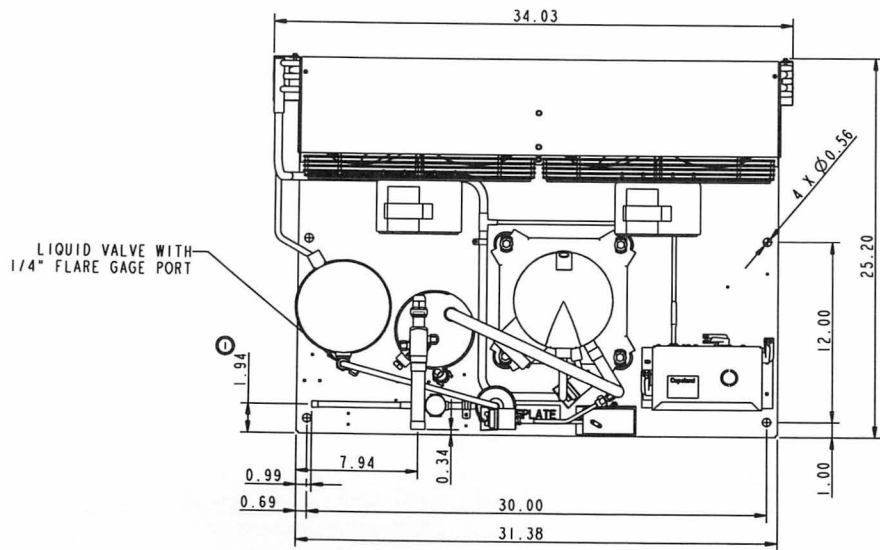

NOTES:

1. PUMPDOWN CAPACITY AT 90% (SEE CHART)
2. ALL OPENINGS MUST BE CAPPED OR PLUGGED.

ECN006351	2	PICTORIALLY UPDATE CLAMP	02-21-13	BAJ	
ECN006351	1	PICTORIALLY UPDATE, DIM WAS: 1.76	01-17-13	BAJ	
ECN006283	0	RELEASED	10-00-12	BAJ	

ENG NOTICE NO.	REV. NO.	REVISIONS	DATE	BY	CHKD	APPR
6		CONFIDENTIALITY NOTICE				

THIS DRAWING AND INFORMATION CONTAINED HEREIN ARE THE EXCLUSIVE PROPERTY OF EMERSON CLIMATE TECHNOLOGIES, INC. AND SHALL BE RETURNED UPON DEMAND AND SHALL NOT BE REPRODUCED IN WHOLE OR IN PART, DISCLOSED TO ANYONE ELSE OR USED, WITHOUT THE WRITTEN CONSENT OF EMERSON CLIMATE TECHNOLOGIES, INC.

DRAWN BY	DATE	SCALE	SUPERSEDES DWG. NO. / REV. NO.
BAJ	10-08-12	1:4	

TITLE	DRAWING NUMBER	SHEET 1 OF 1
REF DWG - WELD UNIT ASSM	496-5702-41	4



INTERPRET PER ASME Y14.5M-1994 AND EMERSON CLIMATE TECHNOLOGIES, INC DESIGN STANDARDS DS2002 DO NOT SCALE DRAWING

THIRD ANGLE PROJECTION

UNLESS OTHERWISE SPECIFIED DIMENSIONS ARE INCH OR (MILLIMETER)

TOLERANCES:  
 2-PLACE ±  
 3-PLACE ±  
 ANGULAR ±

COPYRIGHT EMERSON CLIMATE TECHNOLOGIES, INC. - CONFIDENTIAL

SPECIFICATIONS	
ES NO.	DESCRIPTION
② ES22-122	PACKAGING
③ ES81-159	CLEANLINESS
③ ES81-250	IDENTIFICATION
② ES92-167	REGULATORY COMPLIANCE
③ ES15-143	DECALS

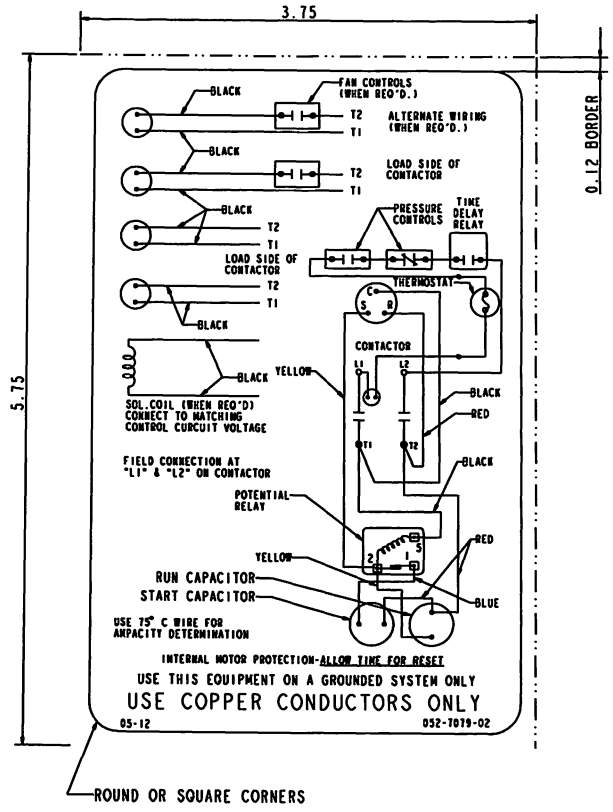

ROUND OR SQUARE CORNERS

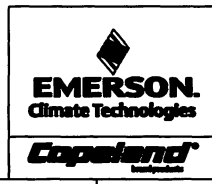

INTERPRET PER ASME Y14.3M-1994 AND EMERSON CLIMATE TECHNOLOGIES, INC. DESIGN STANDARDS DS2002 DO NOT SCALE DRAWING

CRITICAL POINT CHARACTERISTIC

UNLESS OTHERWISE SPECIFIED DIMENSIONS ARE INCHES OR (IN PARENTHESES) TOLERANCES:

2-PLACE ± 0.12  
3-PLACE ±  
ANGULAR ±

ECO/NO/REV	REV. NO.	DESCRIPTION	DATE	BY	CHKD	APPR
ECH005R22	3	REDRAWN, ADDED SPEC & REMOVED NOTE	05-16-12	ASR	TR	
32-9906-086	2	CHANGED FORMAT FOR PROJECT INC	06-06-11	EG	CHE	BST
33-1003-014	1	ADDED COIL	09-19-10	BP	BP	
33-1003-014	0	RELEASED	11-20-03	BP	BP	

6	CONFIDENTIALITY NOTICE	
	THIS DRAWING AND INFORMATION CONTAINED HEREIN ARE THE EXCLUSIVE PROPERTY OF EMERSON CLIMATE TECHNOLOGIES, INC. AND SHALL BE RETURNED UPON DEMAND AND SHALL NOT BE REPRODUCED IN WHOLE OR IN PART DISCLOSED TO ANYONE ELSE OR USED, WITHOUT THE WRITTEN CONSENT OF EMERSON CLIMATE TECHNOLOGIES, INC.	
MATERIAL SPECIFICATION		SUPERSEDES DWG. NO. / REV. NO.
ES15-143	ASR	
DATE	SCALE	DATE FORMAT:
05-16-12	2:1	MM-DD-YY
TITLE	DRAWING NUMBER	SHEET 1 OF 1
DIAGRAM-WIRING	052-7079-02	4

UNCONTROLLED - DO NOT MODIFY

COPYRIGHT EMERSON CLIMATE TECHNOLOGIES, INC. - CONFIDENTIAL

**Emerson Climate Technologies**  
**Integrated Products Division**  
**60Hz Air - Cooled Unit Performance**  
**Release Date:18/08/2003**

**Unit Model:** FJAM-A25Z-CFV-076  
**Compressor:** ZB19KCE-PFV-230  
**Condenser:** 066-0319-02 x 1  
**Fan Motor:** 050-0265-08 x 2  
**Fan Blade:** 083-0034-02 x 2  
**Unit Dimensions:** 25.2``L x 34.0``W x 19.0``H

**Refrigerant:** R-404A  
**Return Gas Temp. (°F):** 65  
**Subcooling (°F):** 5  
**Air Flow Rate (CFM):** 2170  
**Fan Motor Power (Watt):** 420  
**Unit Dwg. No:** 496-5702-41

**Performance: 90°F Ambient Air Temperature**

<u>Evap Temp</u> (°F)	<u>Capacity</u> (Btu/hr):	<u>Power</u> (Watts):	<u>EER</u> (Btu/Wh):	<u>Cond. Temp.</u> (°F)	<u>Temp. Diff.</u> (°F)	<u>Refr. Pd.</u> (Psi)
-5	13,000	2,670	4.9	105.3	15.3	1.2
0	14,400	2,710	5.3	106.7	16.7	1.1
5	16,000	2,740	5.8	107.4	17.4	1.5
10	17,600	2,780	6.3	108.6	18.6	1.7
15	19,300	2,820	6.8	109.9	19.9	2.0
20	21,100	2,860	7.4	111.2	21.2	2.3
25	23,000	2,900	7.9	112.5	22.5	2.7

**Performance: 100°F Ambient Air Temperature**

<u>Evap Temp</u> (°F)	<u>Capacity</u> (Btu/hr):	<u>Power</u> (Watts):	<u>EER</u> (Btu/Wh):	<u>Cond. Temp.</u> (°F)	<u>Temp. Diff.</u> (°F)	<u>Refr. Pd.</u> (Psi)
-5	11,900	2,950	4.0	114.7	14.7	1.2
0	13,200	3,000	4.4	116.0	16.0	1.1
5	14,600	3,020	4.8	116.7	16.7	1.5
10	16,100	3,060	5.3	117.8	17.8	1.7
15	17,700	3,100	5.7	118.9	18.9	2.0
20	19,400	3,140	6.2	120.1	20.1	2.3
25	21,200	3,190	6.6	121.4	21.4	2.7

**Performance: 110°F Ambient Air Temperature**

<u>Evap Temp</u> (°F)	<u>Capacity</u> (Btu/hr):	<u>Power</u> (Watts):	<u>EER</u> (Btu/Wh):	<u>Cond. Temp.</u> (°F)	<u>Temp. Diff.</u> (°F)	<u>Refr. Pd.</u> (Psi)
-5	10,800	3,270	3.3	124.2	14.2	1.4
0	11,900	3,320	3.6	125.5	15.5	1.2
5	13,200	3,340	4.0	126.0	16.0	1.8
10	14,600	3,380	4.3	127.1	17.1	2.0
15	16,000	3,420	4.7	128.1	18.1	2.3

**Performance 7072**

20	17,600	3,470	5.1	129.2	19.2	2.7
25	19,200	3,510	5.5	130.4	20.4	3.1

**Performance: 120°F Ambient Air Temperature**

<u>Evap. Temp</u> <u>(°F)</u>	<u>Capacity</u> <u>(Btu/hr):</u>	<u>Power</u> <u>(Watts):</u>	<u>EER</u> <u>(Btu/Wh):</u>	<u>Cond. Temp.</u> <u>(°F)</u>	<u>Temp. Diff.</u> <u>(°F)</u>	<u>Refr. Pd.</u> <u>(Psi)</u>
-5	9,530	3,620	2.6	133.6	13.6	1.5
0	10,600	3,670	2.9	134.8	14.8	1.3
5	11,800	3,690	3.2	135.3	15.3	1.9
10	13,000	3,730	3.5	136.2	16.2	2.2
15	14,300	3,770	3.8	137.2	17.2	2.5
20	15,700	3,820	4.1	138.2	18.2	2.8
25	17,200	3,860	4.5	139.2	19.2	3.1

**Performance      7072**

# FJAM-A25Z-CFV-076

HFC, R-404A, 60Hz, 1- Phase, 208/230 V



Availability : Custom US OEM Or Wholesaler

## Service Parts

<u>Reference</u>	<u>Component</u>	<u>Quantity</u>	<u>Description</u>
1	ZB19KCE-PFV-930	1	WELD COMP
4	940-0001-79	1	RELAY-POTENTIAL KIT
6	545-0025-00	1	SHROUD - ASSM
9	083-0034-01	2	BLADE-FAN
10	566-1180-00	1	CONDENSER GROUP
11	577-0421-01	1	TANK-ACCUMULATOR ASSM
13	024-0217-00	2	GUARD-FAN
14	943-0153-00	1	230V ELEC UNIT CONTROL
14	943-0155-00	1	230V EUC W/FAN CYCLING
17	074-7088-00	1	BRACKET-CONTROL MTG
22	050-0265-00	2	MOTOR-FAN
29	066-0319-00	1	CONDENSER-AIR
30	914-0036-03	1	CAP START KIT
31	914-0037-36	1	RUN CAP KIT
36	998-0510-99	1	SERV VALVE KIT 1 1/8 SWT
37	985-7031-01	1	HP CONTROL KIT
39	577-0056-01	1	RECEIVER
43	039-0026-02	1	TRANSDUCER - PRESSURE
47	998-0085-04	1	FANCYCL OUT/IN 185/235
48	998-0085-05	1	FANCYCL OUT/IN 215/265
49	998-0085-06	1	HIPRESS OUT/IN 440/325
51	998-7022-02	1	DISCH LINE T'STAT
53	912-2025-02	1	CONTACTOR KIT
61	929-0113-00	1	HOT KEY CABLE DLT SENSOR
61	929-0114-00	1	EL UNIT CTL SUC PRE TRAN
61	929-0114-01	1	EUC COND TEMP CABLE KIT

Ralph Pettijohn

Page 1 of 1

07/12/2016

# FJAM-A25Z-CFV-076

HFC, R-404A, 60Hz, 1- Phase, 208/230 V



**Production Status:** Custom US OEM Or Wholesaler

## Fan Blades

Part Number:	083-0034-02	Pitch:	Diameter (in):
Qty of Blades per Unit:	2	Rotation:	UI No:
No of Blades:		Bore (in):	Status:
Notes:			
<u>Vendor Name</u>	<u>Vendor Part No</u>		

## Fan Motor

Fan Motor Part No:	050-0265-08	Motor Size (Watts):	Motor Voltage:
Quantity of Motors/Unit:	2	UL Amps:	

## A

Part Number:	577-0421-01	UI No:	294	Ref. Inlet (in):	1.25-12 RL
Qty Per Unit:	1	Status:		Ref. Outlet (in):	0.75 S
Capacity (lbs):	6.11	Length (in):	12.5	Water Inlet (in):	
		Diameter (in):	5.0	Water Outlet (in):	
<u>Vendor Name</u>	<u>Vendor Part No</u>	<u>Pressure (psi)</u>			
REFRIGERATION RESEARCH INC	RRDN	355.0			

## Compressor

Model:	ZB19KCE-PFV-230	Oil Type:	POE
LoLRA:		Init Oil Charge:	49
HiLRA:	73.0	RLA(MCC/1.4):	17.9
Half Winding LRA:			

## Base Valves

<u>Part Number:</u>	<u>Quantity</u>
510-0133-11	1
510-7062-00	1

Ralph Pettijohn

Page 1 of 1

07/12/2016

# FJAM-A25Z-CFV-076

HFC, R-404A, 60Hz, 1- Phase, 208/230 V



**Availability :** Custom US OEM Or Wholesaler

## Mechanical

Unit Height (in):	19.0
Unit Length (in):	25.2
Unit Width (in):	34.0
Ship Weight (lbs):	212.0
Condensor Type:	Air
CopeVap Water Storage:	NA
Liquid Connection Size (in)/Type:	3/8 S
Suction Connection Size (in)/Type:	7/8 S
Discharge Line Size(in):	0.5
Water Inlet (in):	
Water Outlet (in):	
Oil Type:	POE
Oil Recharge Amount (oz):	49

## Electrical

Max Fuse Size:	40
Min Circuit Ampacity:	25.2
Compressor:	ZB19KCE-PFV-230
Compressor LRA - Low:	
Compressor LRA - High:	73.0
Compressor LRA - Half winding:	
Compressor RLA:	17.9
UL:	
UL File #:	
UL Guide Card:	
Amps Per Motor:	
Fan Motor Quantity:	2

## Air - Cooled Unit Performance

Release Date:	18-Aug-2003	Return Gas Temp. (°F):	65
Compressor:	ZB19KCE-PFV-230 x 1	Subcooling (°F):	5
Performance No:	7072	Air Flow Rate (CFM)	2170

### 90°F Ambient Air Temperature

<u>Evap Temp</u> (°F)	<u>Unit Capacity</u> (Btu/hr)	<u>Cond. Temp.</u> (°F)	<u>Temp. Diff.</u> (°F)	<u>EER</u> (Btu/Wh):
-5	13,000	105.3	15.3	4.9
0	14,400	106.7	16.7	5.3
5	16,000	107.4	17.4	5.8
10	17,600	108.6	18.6	6.3
15	19,300	109.9	19.9	6.8
20	21,100	111.2	21.2	7.4
25	23,000	112.5	22.5	7.9

# Remote Wire Drawing 2014

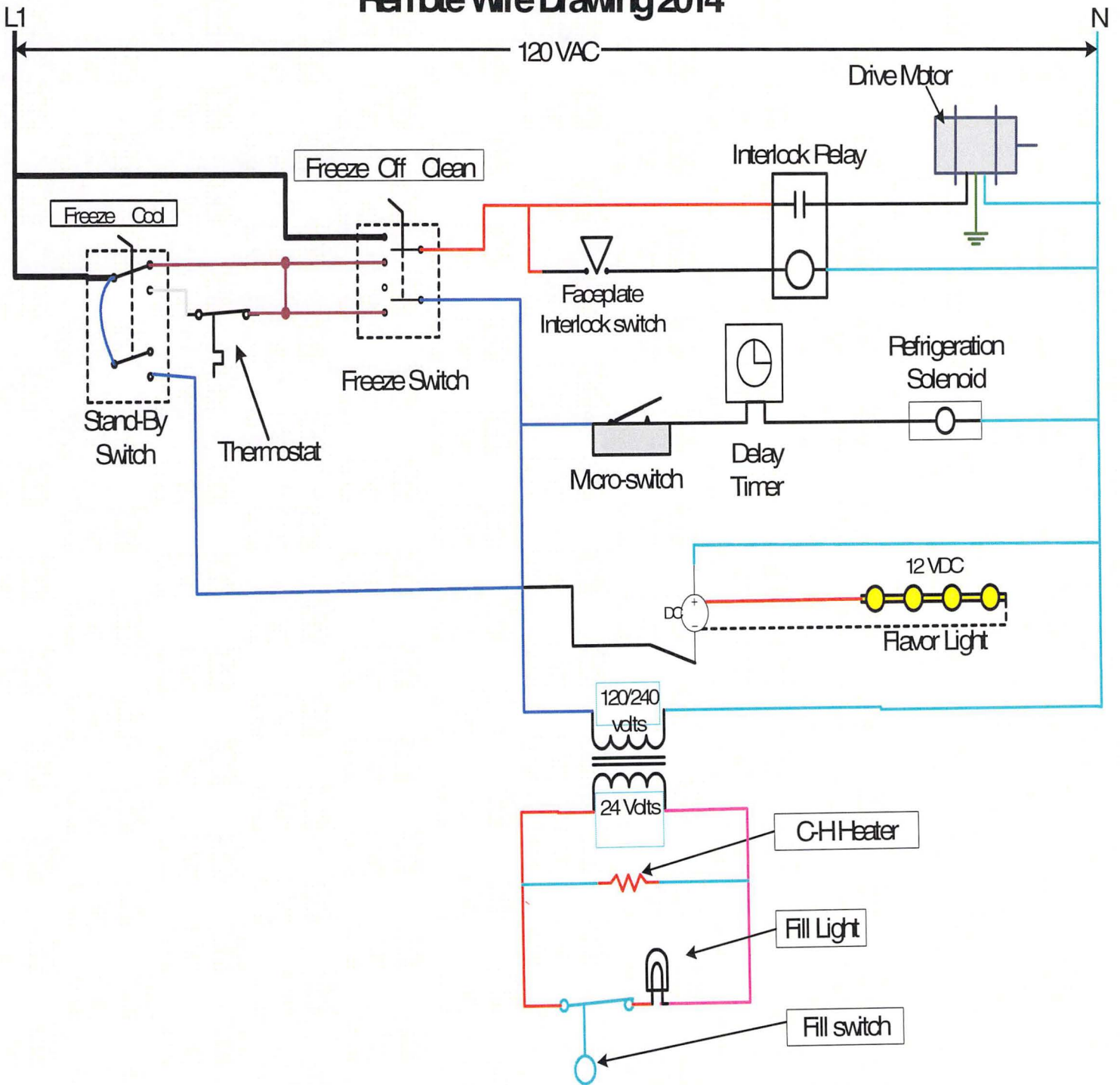

**Engineering Recommendation on:  
REFRIGERANT LINE SIZES FOR REMOTE SYSTEMS  
(R12, R22, R502, R134a and R404A  
Commercial Refrigeration)**

**No. ER-8  
Revised 6-16-99**

**In the selection of gas line sizes, the design engineer should be guided by the following criteria:**

- 1. Assurance of adequate velocity thus insuring oil return capability. (The tube size must be limited to maintain velocities no lesser than 750 fpm for horizontal and down flow and no lesser than 1500 fpm for up flow.)**
- 2. Assurance of acceptable pressure drop. (The tube size should be limited to maintain velocities no greater than 1500 fpm for horizontal and down flow and no greater than 2500 fpm for up flow.)**
- 3. Assurance of satisfactory sound level. (The tube size should be limited to maintain velocities no greater than 3000 fpm.)**
- 4. Assurance of minimum tubing cost. (The tube size should be as small as possible while satisfying the three points mentioned above.)**

**In an attempt to aid the engineer on this subject, we have prepared ready reference tables of suggested line sizes. These sizes have been selected in accordance with the above outlined rules.**

**These tables show recommended suction line sizes for installations where that line is horizontal or down flow. In the event the suction line is up flow, use "one standard size" smaller.**

**EXAMPLE: Where a 7/8" diameter tube is recommended on the table for horizontal or down flow, the recommended size for up flow would be 3/4" diameter.**

**(Continued)**

Engineering Recommendation on:  
**REFRIGERANT LINE SIZES FOR REMOTE SYSTEMS**  
**(R12, R22, R502, R134a and R404A**  
**Commercial Refrigeration)**

No. ER-8  
 Revised 6-16-99

**Table V R404A**

Cond Unit Capacity At System Evaporator Design Temperature	Suction Line Sizes					Liquid Line Sizes
	BTU/Hr.	-40°F	-20°F	0°F	+20°F	
1,200	1/2	3/8	3/8	3/8	3/8	1/4
2,400	5/8	1/2	1/2	3/8	3/8	1/4
3,600	3/4	5/8	1/2	1/2	3/8	1/4
4,800	7/8	3/4	5/8	1/2	1/2	1/4
6,000	1 1/8	7/8	3/4	5/8	1/2	1/4
7,200	1 1/8	7/8	3/4	5/8	1/2	1/4
8,400	1 1/8	7/8	3/4	5/8	1/2	1/4
9,600	1 3/8	1 1/8	7/8	3/4	5/8	1/4
10,800	1 3/8	1 1/8	7/8	3/4	5/8	3/8
12,000	1 3/8	1 1/8	7/8	3/4	5/8	3/8
18,000	1 5/8	1 3/8	1 1/8	7/8	3/4	3/8
24,000	2 1/8	1 5/8	1 3/8	1 1/8	7/8	1/2
36,000	2 5/8	2 1/8	1 5/8	1 3/8	1 1/8	1/2
48,000	2 5/8	2 1/8	2 1/8	1 5/8	1 1/8	1/2
60,000	3 1/8	2 5/8	2 1/8	1 5/8	1 3/8	5/8
72,000	3 5/8	2 5/8	2 5/8	2 1/8	1 5/8	5/8

Tecumseh Engineering Department

/mmr

Typical 5/8" Suction Manifold  
for 3 Dispenser set-up.

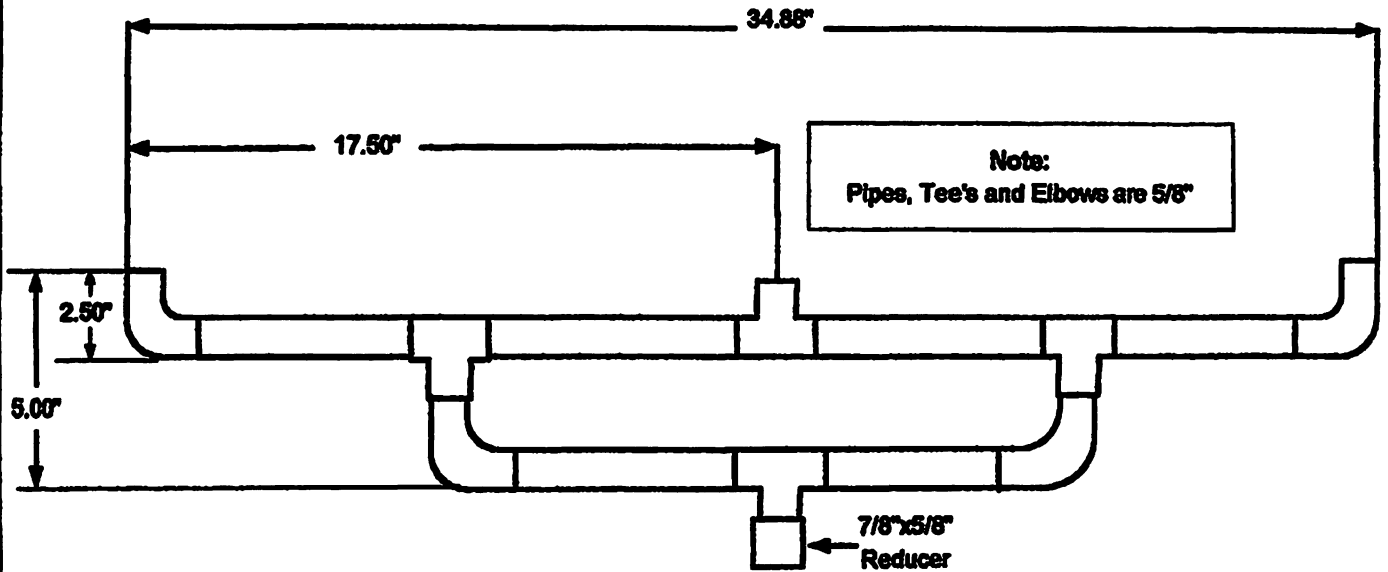

Note:  
Pipes, Tee's and Elbows are 3/8"

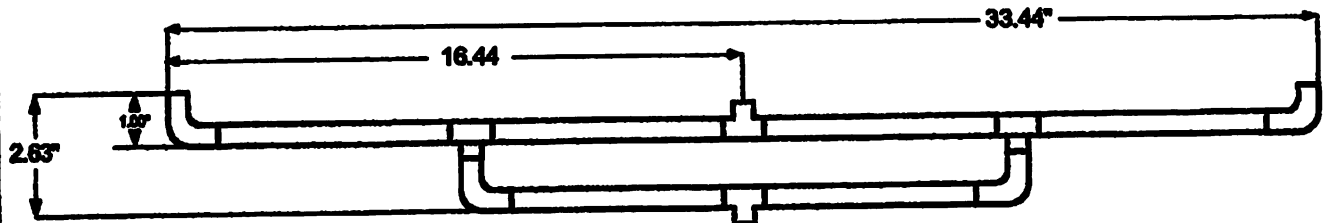

Typical 3/8" High side manifold  
for 3 Dispenser set-up.

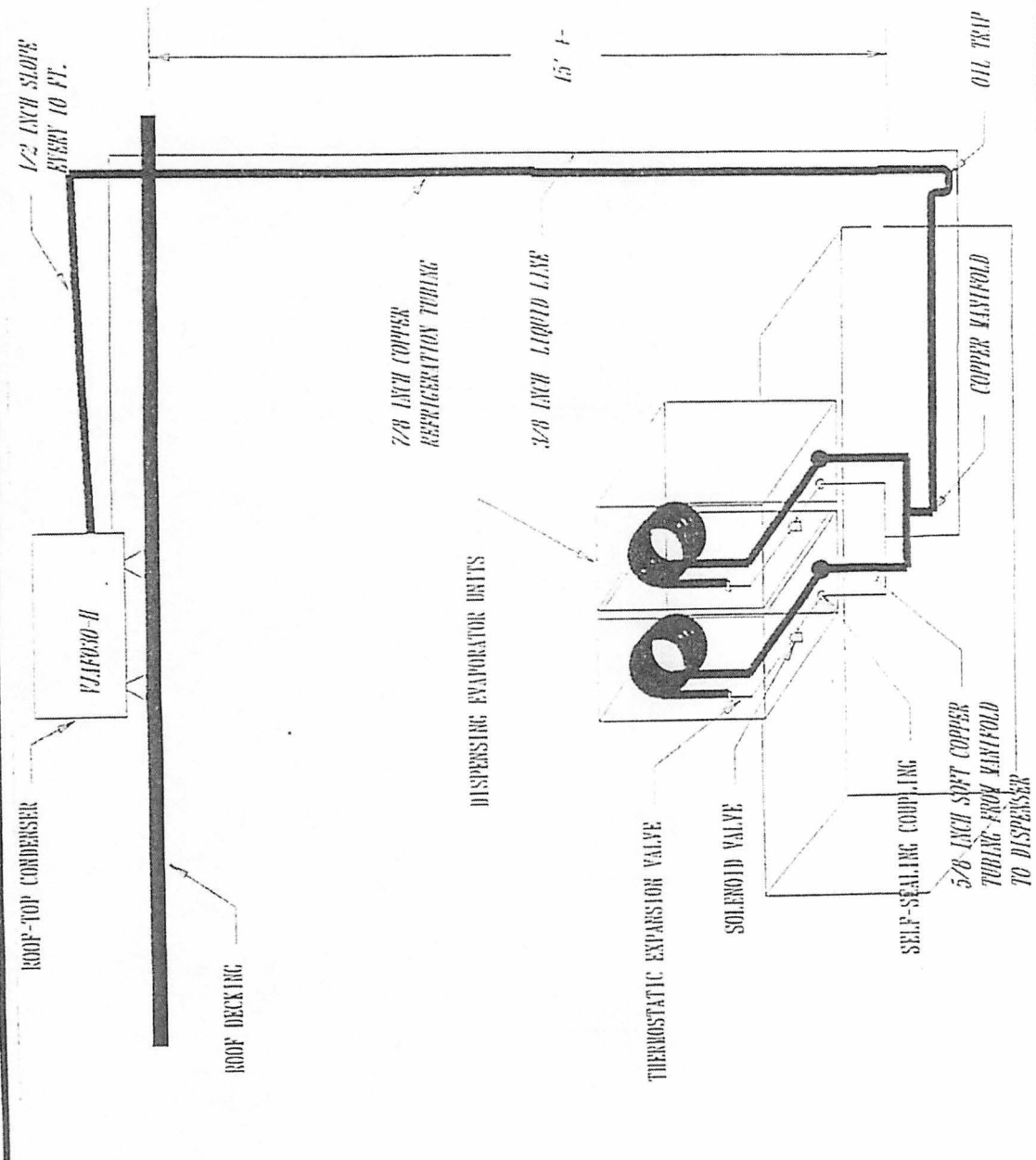

FROSTY FACTORY OF AMERICA

MATERIAL DRAWN #

SCALE .03

TITLE R/W/P/E

REVIS

PART NO. DATE 1-10-05

2051081

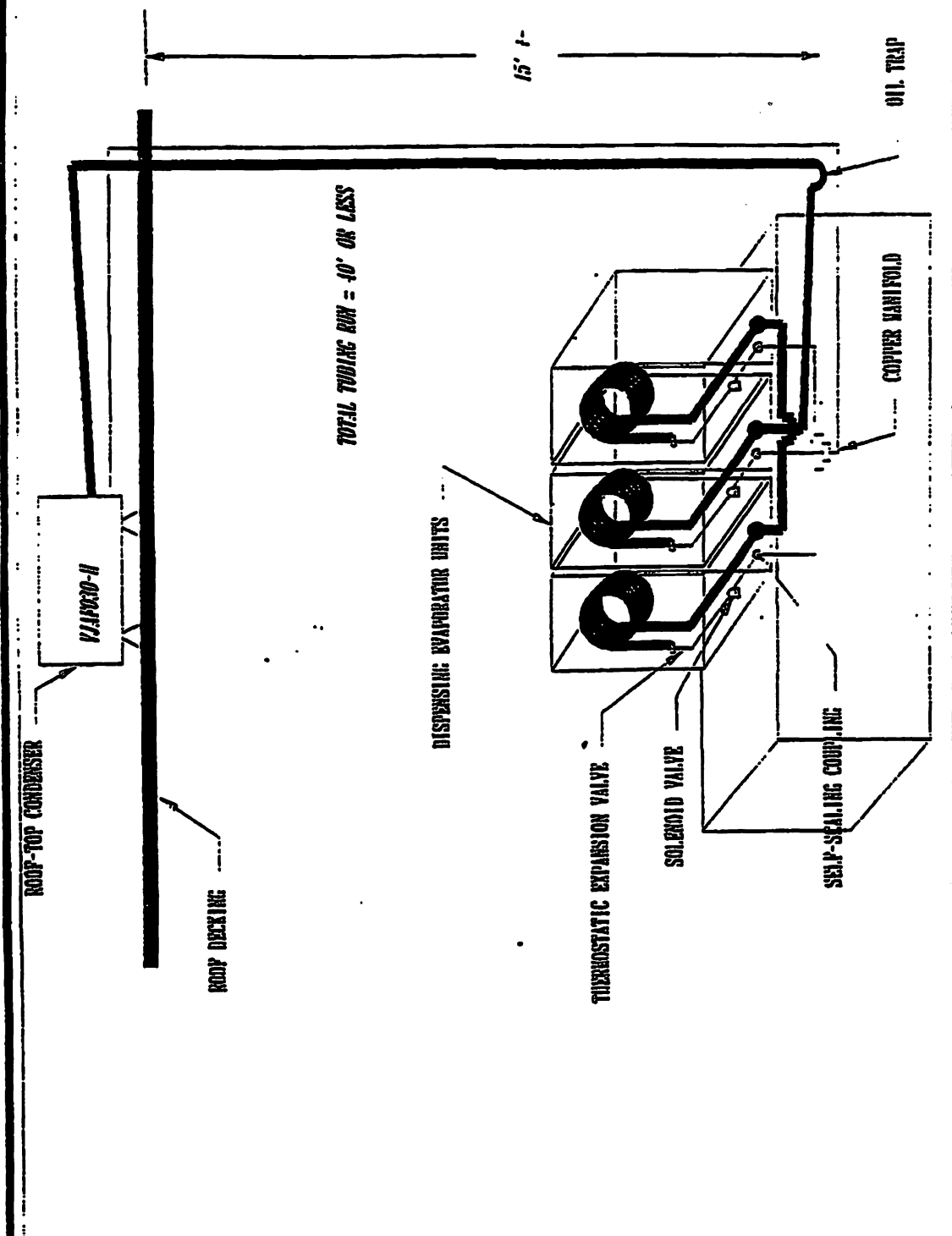

**FROSTY FACTORY  
OF AMERICA**

**MATERIAL**  
**DRAWN #**

**SCALE .07**

**TITLE** *REWRITE*

**REVIS**

**PART NO.**  
**DATE 1-10-55**

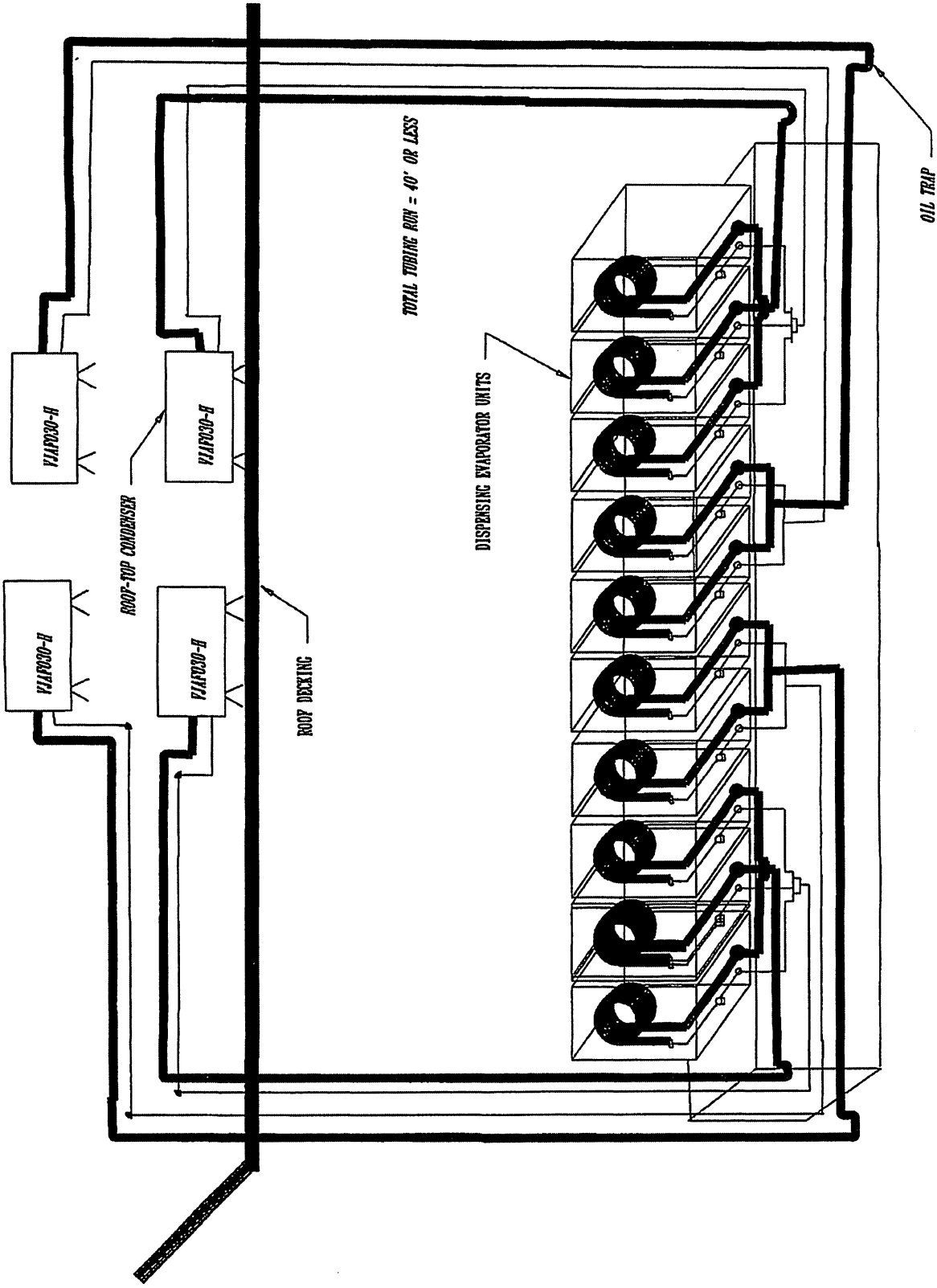

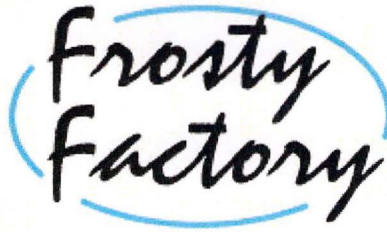

## WARRANTY

*Frosty Factory of America, Inc., the warrantor, providing that the conditions set forth herein are met by the Purchaser-User, warrants to the original purchaser-user that Frosty Factory Frozen Drinks machines, herein referred to as the "unit" is free from defects in factory workmanship and materials. This warranty is for the period of one year on all components of the unit with the exception of the compressor and the evaporator, which has a warranty period of five years. Also excluded are normal maintenance items i.e. O-rings, seals, belts, etc. During the warranty periods, Frosty Factory of America, Inc., agrees to repair or replace (at its option) without cost to purchaser-user except transportation charge any part or parts of said unit proved to the satisfaction of Frosty Factory of America, Inc. to be defective when sold. The warrantor shall not be responsible for any expenses incurred for service or repairs performed by a person or entity other than the Warrantor, unless specifically authorized by the Warrantor, and the repair falls in the 1 year labor warranty period. Past 1 year, service calls or repairs other than those covered by the conditions set forth in this Warranty will be made at the expense of the original Purchaser-User.*

*This warranty is in lieu of all other warranties, express or implied, including any warranties of merchantability or fitness for a particular use, and releases Frosty Factory of America, Inc. from all other obligations whatever. Frosty Factory of America, Inc. neither assumes nor authorizes any other person to assume from the warrantor any other liability in connection with the identified unit. This warranty is not assignable. "Original Purchaser-User" shall mean only such person or entity for which the identified unit is originally purchased and installed. Return of the OWNER'S WARRANTY CARD to the Warrantor is required for warranty coverage. If not received by the warrantor, warranty coverage begins the date of shipment.*

*All inquiries to our Factory about unit must be accompanied by the unit serial number.*

*This warranty does not apply to damage to said unit occurring in transit, or damage caused by unauthorized alternations, fire, accidents, artificially generated electric currents, Acts of God, misuse or abuse, or by any other cause whatsoever other than defects in Factory workmanship or material. This warranty does not apply to damage or loss of any products, refrigerant, property, or loss of income or profits due to the malfunctioning of said unit, nor to transportation or special charges for state sales or other taxes. This warranty also does not cover issues that are caused by lack of maintenance that is to be performed weekly as per cleaning instructions, nor is the adjustment of the viscosity for product thickness.*

01/2016