

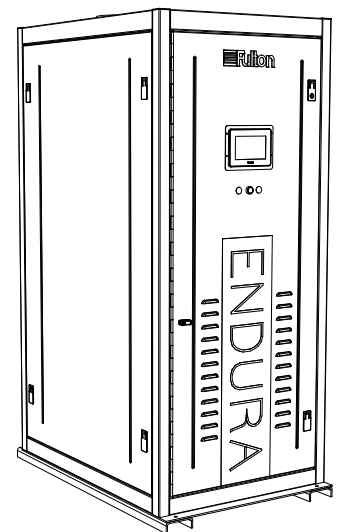

INSTALLATION, OPERATION AND MAINTENANCE MANUAL

Endura (EDR)
Condensing Hydronic Boilers
750,000 - 2,000,000 BTU/HR
Featuring PURE Control™



Serial/ National Board Number _____

Model _____

Fulton Order _____

Owner _____

Site Name _____

Date _____

DIGITAL MANUAL:



Scan to download the latest digital copy of this manual



Introduction	1-1
Overview	1-2
Warnings & Cautions.....	1-2
Disclaimers and Local Codes	1-2
Technology Terminology	1-3
Installation	2-1
Product Overview.....	2-2
Placement & Rigging	2-3
Clearances and Serviceability	2-5
Install Boiler Trim	2-5
Install Water Piping.....	2-6
VARIABLE PRIMARY PIPING ARRANGEMENT	2-7
PRIMARY-SECONDARY PIPING ARRANGEMENT.....	2-10
Meet Water Chemistry Requirements.....	2-11
PREVENT OXYGEN CONTAMINATION.....	2-12
ELIMINATE SYSTEM AIR	2-12
Fill the Boiler With Water	2-12
Gas Supply Piping	2-12
INLET GAS PRESSURE	2-13
GAS PRESSURE REQUIREMENTS.....	2-13
LINE GAS PRESSURE REGULATION.....	2-13
GAS PIPING INSTALLATION	2-14
COMPONENTS REQUIRING VENTILATION TO THE OUTDOORS	2-15
Install Condensate Drain Trap.....	2-17
SINGLE BOILER DRAIN TRAP	2-17
MULTIPLE BOILERS SHARING A COMMON DRAIN TRAP	2-17
Install pH Neutralization Kit.....	2-21
Venting Requirements	2-22
Combustion Air Intake	2-23
COMBUSTION AIR SUPPLY FROM THE BOILER ROOM.....	2-24
COMBUSTION AIR DUCTED FROM THE OUTDOORS.....	2-25
Combustion Air Filter	2-26
Flue Gas Exhaust Venting	2-26
Common Flue Gas Venting Layouts.....	2-28
COMMON VENTING EXHAUST BACKFLOW PREVENTION.....	2-30
Venting Terminations	2-30
WALL THIMBLE INSTALLATION	2-31
ROOF VENT TERMINATION.....	2-31
SIDE WALL VENT TERMINATION.....	2-31
Removing an Existing Boiler	2-35
Assembly of Fulton Multi-Skid Systems.....	2-35
Electrical Connections and Devices	2-37
JUNCTION BOX LOCATIONS FOR FIELD WIRING	2-42
ELECTRICAL AND CONTROLS OPTIONS.....	2-42
LEAD/LAG INTEGRATED SEQUENCING WIRING.....	2-42
INTEGRATION WITH THE MODSYNC SEQUENCING SYSTEM	2-43

SUPPLIER HEADER TEMPERATURE SENSOR.....	2-43
OUTDOOR AIR TEMPERATURE SENSOR KIT	2-43
DOMESTIC HOT WATER (DHW) TEMPERATURE SENSOR.....	2-44
MOTORIZED ISOLATION VALVE CONTROL	2-44
AUXILIARY SAFETY INTERLOCK FOR EXTERNAL DEVICE.....	2-44
VARIABLE SPEED SYSTEM PUMP CONTROL	2-44
DEDICATED BOILER PUMP CONTROL	2-44
ALTERNATE COMMUNICATION PROTOCOL GATEWAY	2-45
REMOTE BOILER ENABLE/DISABLE.....	2-45
REMOTE ANALOG SETPOINT	2-45
GENERAL ALARM CONTACT.....	2-45
LOW WATER CUT OFF.....	2-45
BOILER STATUS CONTACT	2-45
BOILER DEMAND CONTACT	2-45
EMERGENCY STOP (E-STOP)	2-45

Operation	3-1
Perform Pre-Start-Up Inspection.....	3-2
Fill and Purge the System.....	3-2
Commission The Boiler.....	3-3
SYSTEM DESIGN AND BOILER OPERATION.....	3-3
Adjusting and Verifying Combustion	3-4
Combustion Parameters.....	3-6
Siemens LMV3 Control	3-8
BEFORE MODIFYING LMV PARAMETERS.....	3-10
ADJUSTING FUEL/AIR CURVE.....	3-10
STEPS TO ENTER PARAMETERS	3-11
MANUAL CONTROL (MANUAL REQUEST FOR OUTPUT)	3-12
PARAMETER BACKUP	3-13
PARAMETER RESTORE	3-14
Using the Fulton PURE Control® Interface.....	3-16
NAVIGATION.....	3-16
Fulton PURE Control® Menu Screens.....	3-17
BOILER CONTROL.....	3-14
BOILER STATUS	3-14
SAFETY DEVICE STATUS.....	3-14
OPERATOR CONTROL	3-14
BOILER HISTORY	3-15
ALARM HISTORY	3-15
MAINTENANCE LOG.....	3-15
ISOLATION VALVE.....	3-15
PRIMARY PUMP	3-15
SECONDARY PUMPS	3-16
LEAD/LAG.....	3-16
LEAD/LAG CONFIGURATION	3-16
PID CONTROL	3-17
LOCAL PID	3-17
LOW FIRE HOLD.....	3-17

FREEZE PROTECTION	3-17
OUTLET MONITORING.....	3-17
COLD START.....	3-17
SETPOINT	3-18
SETPOINT CONFIGURATION.....	3-18
OUTDOOR RESET.....	3-18
BMS ANALOG (4-20MA AND 0-10VDC).....	3-18
SCHEDULING.....	3-18
TRENDING	3-18
ADMIN.....	3-19
SYSTEM CONFIGURATION	3-19
SENSOR STATUS.....	3-19
AUXILIARY CONFIGURATION.....	3-19
UNIVERSAL DATA CONFIGURATION	3-19
USER CONFIGURATION	3-19
Commissioning Mode	3-20
Perform Test of Limit Controls.....	3-20
Perform Test of Low Gas Pressure Switch.....	3-20
Perform Test of High Gas Pressure Switch.....	3-20

Maintenance **4-1**

General.....	4-2
Daily Inspection Schedule	4-2
Weekly Maintenance Schedule	4-2
Tool List	4-3
Monthly Maintenance Schedule.....	4-4
Procedure for Inspecting the Air Inlet Filter	4-4
Replacing or Updating the Boiler Control.....	4-4
Annual Maintenance Schedule.....	4-5
Removing and Cleaning the Flame Rod	4-6
Removing and Cleaning Burner Assembly	4-6
Verification of Ignition Gap	4-8
After All Repairs and Maintenance	4-9
Parts Diagrams.....	4-10
Troubleshooting.....	4-17

Service **5-1**

Pre-Commissioning Installation Checklist.....	5-3
Installation & Operation "Start-Up" Report	5-5
Annual Maintenance Checklists	5-7
Notes	5-17

INTRODUCTION

1

INSTALLATION

2

OPERATION

3

MAINTENANCE

4

SERVICE DOCUMENTS

5

Overview

Prior to shipment, the following inspections and tests are completed to ensure the highest standards of quality:

- Material inspections
- Manufacturing process inspections
- American Society of Mechanical Engineers (ASME) welding and hydrostatic test inspection
- Gas train leak test
- Hipot test and electrical inspection
- Test fire operating and safety tests
- Final inspection
- Crating inspection

This Installation, Operation and Maintenance Manual is provided as a guide to the correct operation and maintenance of your Fulton equipment, and should be read in its entirety and be made permanently available to the personnel responsible for the operation of the boiler. It should not, however, be considered as a complete code of practice, nor should it replace existing codes or standards which may be applicable. Fulton reserves the right to change any part of this manual without notice.

Installation, start-up, and maintenance of this equipment can be hazardous and requires trained, qualified installers and service personnel. **Trained personnel are responsible for the installation, operation, and maintenance of this product, and for the safety assurance of installation, operation, and maintenance processes. Do not install, operate, service or repair any component of this equipment unless you are qualified and fully understand all requirements and procedures. Trained personnel refers to those who have successfully completed Fulton Service School training specific to this product.**

Installers, technicians, and operating personnel must, at all times, observe all warnings, cautions, and notes in literature, on stickers and labels, and any additional safety precautions that apply. Follow all safety codes and wear appropriate safety protection. Follow all jurisdictional codes and consult any jurisdictional authorities prior to installation.

Warnings & Cautions

WARNINGS and CAUTIONS appear in various chapters of this manual. It is critical that all personnel read and adhere to all information contained in WARNINGS and CAUTIONS.

- WARNINGS must be observed to prevent serious injury or death to personnel.
- CAUTIONS must be observed to prevent damage or destruction of equipment or loss of operating effectiveness.

All Warnings and Cautions are for reference and guidance purposes, and do not substitute for required professional training, conduct, and strict adherence to applicable jurisdictional/professional codes or regulations.

Regulatory and Standards Conformity

Installation of the equipment shall conform to all the requirements or all national, state and local codes established by the Authorities Having Jurisdiction (AHJ) or, in the absence of such requirements, in the US to the National Fuel Gas Code ANSI Z223.1/NFPA 54 latest edition, the National Electric Code (NEC) NFPA 70 latest edition, and the requirements in this manual. The AHJ should be consulted prior to installation.

When required by local codes, the installation must conform to the American Society of Mechanical Engineers Safety Code for Controls and Safety Devices for Automatically Fired Boilers (ASME CSD-1). The controls and safety devices of this boiler meet the requirements set forth in the ASME CSD-1 standard. The Manual Reset High Limit (MRHL) provided with this boiler is listed to UL 353 per ASME CSD-1 requirements.

AXA XL requires compliance with ASME CSD-1 up to 12,500,000 BTU/hr. XL Catlin, GE GAP, and IRI have been replaced by AXA XL.

FM Global follows ASME CSD-1 requirements. FM Global will accept any UL or ETL listed and labeled packaged boiler up to and including 2,500,000 BTU/hr without requiring FM Global approved components. FM Global requires boilers with capacities above 2,500,000 BTU/hr and up to 12,500,000 BTU/hr use FM Global approved components when applicable and available.

The boiler pressure vessel is manufactured and stamped in accordance with ASME Boiler and Pressure Vessel Code, Section IV for a maximum allowable working pressure and operating temperature of 160 psig and 210°F (99°C) respectively.

Input ratings and efficiency have been certified by AHRI based on standard test procedures prescribed by the United States Department of Energy.

Technology Terminology

Term	Definition
AFS	Air Filter Switch
ALM	Accurate Lambda Meter, a wideband O2 sensor controller
ANSI	American National Standards Institute, an organization that oversees the development of voluntary consensus standards in the United States
AC	Alternating Current
AS	Air Switch
ASME	American Society of Mechanical Engineers, an organization that sets internationally recognized industrial and manufacturing codes and standards that enhance public safety
BAC	BACnet building integration protocol
BAS, BMS	Building Automation Systems, also known as BMS, Building Management System
BTU	British Thermal Unit
BTU/HR	BTU per Hour, 1 BTU/hr = 0.29 W
CFH, SCFH	Cubic Feet Per Hour, Standard Cubic Feet Per Hour, 1 CFH = 0.028 m3/hr
CSR	Condensate Safety Relay
DC	Direct Current
DHW	Domestic Hot Water
DMM	Digital Multimeter
ECM	Electronically Commutated Motor
E-Stop	Emergency Stop
Ethernet	A wired networking technology that enables devices to communicate efficiently, commonly used in local and wide-area networks.
Firmware	Low-level software that provides essential instructions for hardware and bridges hardware with higher-level software
Flame-by-Wire	A system which replaces conventional combustion controls with electronic signals to actuators
GND	Ground
GUI	Graphical User Interface
HGP(S)	High Gas Pressure (Switch)
HMI	Human Machine Interface, the hardware and software components for operator interaction
Hydronic	A comfort heating or cooling system that uses water or glycol blends as the heat transfer medium
ID (I.D.)	Inside Diameter
ILK	Interlock
IOM	Installation, Operation and Maintenance Manual
IT	Ignition Transformer
LCI	Limit Control Input on the flame safeguard
LGP(S)	Low Gas Pressure (Switch)
LMV	Siemens Burner Management (Flame Safeguard) Control
LWCP	Low Water Cut-off Probe
LWSR	Low Water Safety Relay
Manometer	A tool used to measure the pressure of gases or liquids, typically a U-shaped tube filled with liquid to indicate pressure differences

Term	Definition
MBH	1,000 BTU per Hour
MMBH	1,000,000 BTU per Hour
Modbus	A communication protocol for industrial automation that allows devices to communicate over a network
MRHL, HLTC	Manual Reset High Limit, also referred to as High Limit Temperature Control
MV	Main gas valve
MV Downstream	Main gas valve downstream setpoint gas pressure
NC (N.C.)	Normally Closed
NFPA	National Fire Protection Association
NO (N.O.)	Normally Open
NOx	Nitrogen oxides, primarily nitric oxide (NO) and nitrogen dioxide (NO ₂), produced during combustion processes
NPT	National Pipe Thread
NTC	10k Ohm Thermistor, a type of temperature sensor
O2	Oxygen, typically used in the context of excess Oxygen in the combustion flue gases
OAT	Outdoor Air Temperature
OCI	Operator Control Interface
OD (O.D.)	Outside Diameter
OTC	Operating Temperature Control
PN, P/N	Part Number
PB	Push Button
PCB	Printed Circuit Board
PID	Proportional, Integral, Derivative
PLC	Programmable Logic Controller
POC	Proof of Closure
PPM	Parts per Million
Primary Pump	A dedicated boiler circulator circulator pump used in primary-secondary piping arrangements
Process Variable	The real-time value measured from the system, such as temperature or pressure, which the PID controller continuously monitors to maintain the process
PS, PSU	DC Power Supply (Unit)
PSI	Pounds per Square Inch
PURE Control	Fulton's integrated boiler control system that optimizes temperature control and lead/lag functionality, manages internal boiler systems, and integrates with automation systems
PWM	Pulse Width Modulation
QRA	An Ultra Violet Flame Scanner
RS-485	A serial communication standard that enables communication between multiple devices
RTD	Resistance Temperature Detectors, a type of temperature sensor
SAS	An actuator used for automatic gas pressure setpoint adjustment of the SKP regulator
Secondary Pump	The pump(s) used to circulate flow through the building system loop, in variable primary arrangements secondary pump(s) also circulate flow through the boilers
Setpoint	The desired temperature or pressure target value that the PID controller adjusts system inputs in order to reach and maintain
SKP	An electro-hydraulic gas safety shut off actuator

Term	Definition
SIB	Signal Interface Board
SM	Servo Motor or Stepper Motor, used for various motion control functions
Software	High level user-interaction application
SOLA	Honeywell or Resideo Flame Safeguard Control
VAC	Volts Alternating Current
VDC	Volts Direct Current
VFD, VSD	Variable Frequency Drive or Variable Speed Drive, used to control the speed of an AC motor
W	Watts
W.C.	Water Column, used as a measurement of pressure as Inches of Water Column, "W.C.
XF	AC Power Transformer

PAGE INTENTIONALLY LEFT BLANK

INTRODUCTION

1

INSTALLATION

2

OPERATION

3

MAINTENANCE

4

SERVICE DOCUMENTS

5

WARNING

All information in this manual is for reference and guidance purposes, and does not substitute for required professional training, conduct, and strict adherence to applicable jurisdictional/professional codes and regulations.

CAUTION

The standard configuration for this boiler is certified for indoor installation only.

This boiler is not designed for use in systems where water is continuously replenished. The warranty is valid for closed loop systems only.

Fulton cannot be held responsible for the selection, engineering, installation, or sizing of any additional equipment or components of the hydronic heating system.

Product Overview

Prior to the performance of installation, operation, or maintenance procedures, personnel should become familiar with the equipment (Table 1 and Figure 1) and its components.

The Fulton Endura hot water boiler is an automatic, fuel-fired, ultra high-efficiency boiler. Combustion air supply may be ducted to the boiler from the outdoors or utilize conventional methods.

The boiler is capable of sidewall venting when the appropriate venting materials are used, and when permitted by local code requirements.

This boiler is ETL listed and labeled to Underwriters Laboratories (UL) Edition 7 UL Standard for Safety Commercial-Industrial Gas Heating Equipment for indoor installation. The boiler heat exchanger is manufactured and bears the "H" stamp in accordance with American Society of Mechanical Engineers (ASME) Boiler and Pressure Vessel Code, Section IV for a maximum allowable working pressure and temperature of 160 psi and 210° F (99° C) respectively. It is hydrostatically tested, test fired and shipped as a complete packaged unit.

Fuel, water and electrical connections are similar to other boilers of this type.

Please be aware of which burner and control configuration has been designed specifically for your application.

This boiler is to be installed as part of a hydronic heating system. A qualified engineer must be consulted for the selection of the equipment and components of the heating system. Various system conditions can result in incorrect heat distribution to users of the heating system.

Each Endura Boiler is supplied with the following:

- Integrated combustion supervision and temperature operating control
- Operating and high temperature probe(s) in pressure vessel
- Low water probe(s) in pressure vessel
- ASME safety relief valve
- Installation, Operation, and Maintenance Manual
- Test fire report
- Wiring diagram
- Temperature and pressure (T&P) gauge

The customer should examine the equipment for any damage. It is the responsibility of the installer to ensure all parts supplied with the equipment are fitted in a correct and safe manner.

Placement & Rigging

Proper placement of your Fulton product is essential. Attention paid to the following points will save a great deal of difficulty in the future. Correct placement is the first step to trouble-free installation, operation, and maintenance.

Adhere to the following for placement and rigging:

1. Check building specifications for permissible floor loading. Use Table 1 for unit reference.
2. Conform to all the requirements of all national, state and local codes established by the authorities having jurisdiction and/or the U.S. to the National Fuel Gas Code, latest edition. Authorities having jurisdiction should be consulted before installations are made. Where required by local codes, the installation must conform to American Society of Mechanical Engineers Safety Code for Controls and Safety Devices for Automatically Fired Boilers (ASME CSD-1).
3. Since an external electrical source is utilized, the boiler, when installed, must be electrically ground in accordance with the National Electric Code, American National Standards Institute (ANSI) National Fire Protection Association (NFPA) 70, latest edition.
4. The boiler is designed for room temperatures above 32°F (0°C) and not exceeding 120°F (48.9°C)
5. Install so that all system components are protected from water (dripping, spraying, rain, etc.) and debris (dry wall dust, insulation particles, etc.) during boiler operation and service.
6. Install on a level, non-combustible surface in the vertical position. Concrete is strongly recommended. The surface must be elevated a minimum of 4" (102 mm) above the floor. Do not install the boiler on springs.
7. Provide combustion and ventilation air in accordance with applicable provisions of local building codes or: USA – NFPA 54/ANSI Z223.1, Section 5.3, Air for Combustion and Ventilation.
8. Locate the boiler so that the combustion air supply and exhaust piping between the boiler and outside wall/roof are within the maximum lengths for horizontal or vertical venting if sealed combustion will be used. See **Clearances and Serviceability section** of this manual.



WARNING

All information in this manual is for reference and guidance purposes, and does not substitute for required professional training, conduct, and strict adherence to applicable jurisdictional/professional codes and regulations.

Competent personnel in accordance with all applicable local codes should carry out the installation of the Fulton equipment. All state and jurisdictional codes beyond the scope of the applicable ASME Boiler and Pressure Vessel Codes, for its corresponding classification, should be followed in all cases. Jurisdictional authorities must be consulted prior to installation.

A competent rigger experienced in handling heavy equipment should handle rigging your equipment into position.

The equipment must be installed on a non-combustible surface.

Failure to provide required and safe access to the equipment could impede commissioning and maintenance. Service technicians are instructed not to commence commissioning if hazardous conditions exist.

Failure to provide proper minimum clearances between equipment and combustible materials may result in fire.



CAUTION

Do not allow weight to bear on equipment components to prevent damage.

Do not use to directly heat swimming pool.

TABLE 1 - BOILER DIMENSIONS AND OPERATING SPECIFICATIONS

Specifications	EDR	750	1000	1500	2000
Rated Input Capacity ¹	MBTU/HR	750	1,000	1,500	2,000
Output at AHRI-1500 conditions	MBTU/HR	728	953	1,402	1,874
Fuel Consumption at Capacity ²	FT3/Hr	735	980	1,471	1,961
Nat. Gas Pressure Required ³	W.C.	4-28	4-28	4-28	4-28
Full Load Amps ⁴ (120/1/60)	AMP	10	10	20	20
Minimum Circuit Ampacity	AMP	12.5	12.5	25	25
Water Content	GAL	50	50	104	102
Dry Weight	LBS	1,430	1,430	2,260	2,360
Operating Weight	LBS	1,848	1,848	3,128	3,210
Dimensions	EDR	750	1000	1500	2000
A. Boiler Width	IN	28	28	33.9	33.9
B. Boiler Height	IN	67.8	67.8	80	80
C. Boiler Depth	IN	50.2	50.2	60.6	60.6
Connections	EDR	750	1000	1500	2000
D. Flue Gas Vent ⁵ (dia)	IN	6	6	6	8
E. Combustion Air Inlet ⁵ (dia)	IN	6	6	8	8
F. Water Inlet (dia)	IN	2	2	4	4
G. Water Outlet (dia)	IN	2	2	4	4
H. Gas Inlet (dia)	IN	1	1	1.5	1.5
I. Condensate Drain (dia)	IN	1	1	1	1
Minimum Clearance	EDR	750	1000	1500	2000
J. Front	IN	36	36	36	36
K. Rear	IN	24	24	24	24
L. Top	IN	18	18	18	18
M. Sides	IN	1	1	1	1

NOTES:

- 1) May be operated up to 10,000 feet elevation, and up to 1,000 feet elevation at 80° F without de-rate. Consult your Fulton Representative for capacities at higher elevation.
- 2) Applies to natural gas with a calorific value of 1,020 BTU per FT3.
- 3) Standard natural gas configurations only. Alternate or custom configurations may have different requirements; always review the boiler nameplate before installation.
- 4) Standard electrical configurations only. Alternate or custom configurations may have different requirements; always review the boiler nameplate before installation. Voltages lower than 120V can result in decreased output capacity.
- 5) An appliance adapter may be required.
- 6) Specifications and dimensions are approximate and for reference only. Fulton practices continuous product improvement and reserves the right to change specifications and/or dimensions without notice.

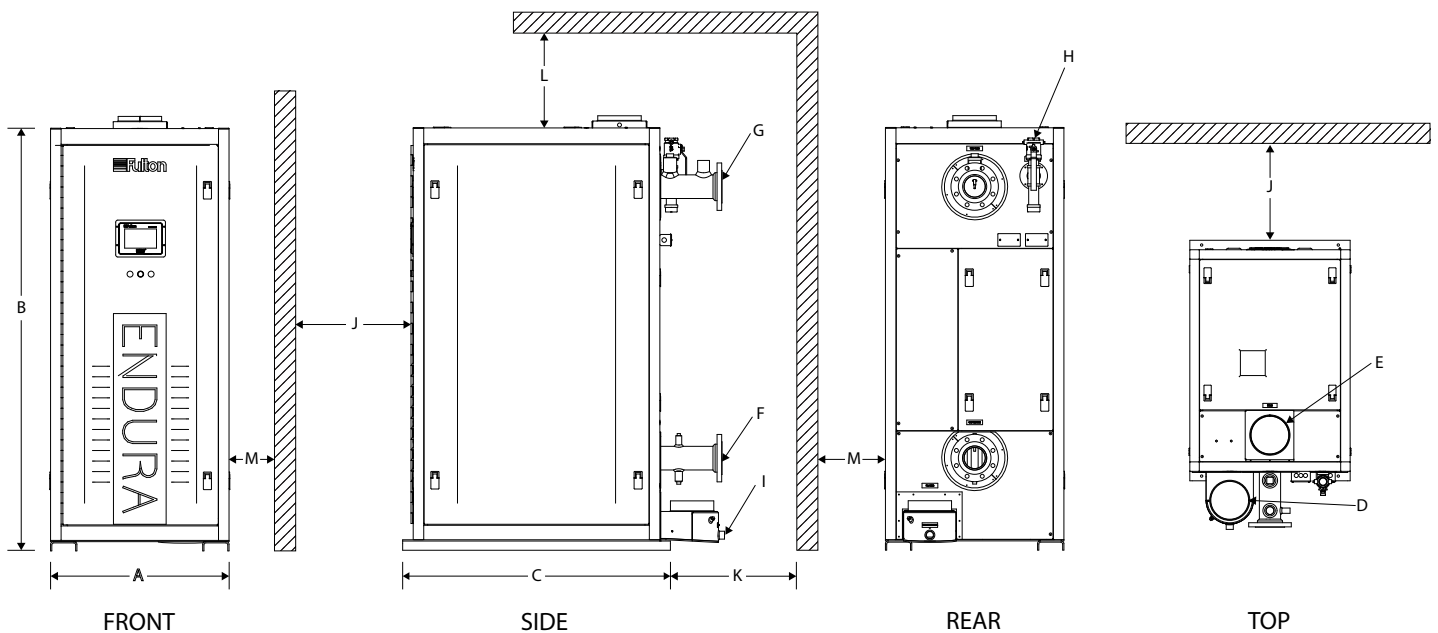

FIGURE 1 - VIEWS OF ENDURA HYDRONIC BOILER

Clearances and Serviceability

Adhere to the following for clearances and serviceability:

1. All local and national codes (NFPA, ANSI, UL, CSA, ASME) must be followed for proper clearances and serviceability of your boiler. Authorities having jurisdiction should be consulted before installations are made.
2. Appropriate front, back, side and top clearances must be maintained (Figure 1). This will allow access around the equipment to facilitate maintenance and a safe work environment. A 1-inch (25.4 mm) side clearance is acceptable between any number of boilers. Custom configurations may not allow 1-inch (25.4 mm) side clearance. Although a 1 inch (25.4 mm) side clearance is permitted, allowing 24 inches (610 mm) will facilitate and expedite maintenance and any advanced troubleshooting.
 - *NOTE: Side panels are latched; however, maintenance and service does not require boiler access through side panels. All maintenance and service can be performed from front, rear, and top of boiler.*
3. Ensure the installation provides sufficient clearance and visibility for access to all labels, inspection points, the safety relief valve, and for maintenance.
4. Do not mount boiler room accessories or other components directly to the boiler cabinet frame or jacket panels as this may impede maintenance.

Install Boiler Trim

Each Endura boiler is supplied with a safety relief valve sized in accordance with ASME requirements. Adhere to the following installation requirements:

1. The safety relief valve (Figure 2) must:
 - » Be connected to the coupling located in the top of the boiler.
 - » Be installed in the upright vertical position.
- *NOTE: Safety relief valve size is determined by trim pressure and is supplied in the trim kit along with appropriate bushing, inlet and outlet sizes. See Table 2.*

2. The discharge pipe must:

- » Not have a diameter less than the full area of the valve outlet.
- » Be as short and straight as possible and so arranged as to avoid undue stress on the valve.
- » Be supported by means other than the safety valve itself.
- » Be piped to avoid danger of scalding personnel.

- *NOTE: Each boiler is equipped with a pressure-temperature gauge to be installed in the outlet piping section of the boiler. Gauge must not be isolated from the boiler by any valve.*

TABLE 2 - SAFETY RELIEF VALVE INLET AND OUTLET SIZES

Model	Trim Pressure PSI (kPa)	Inlet Size inch (mm)	Outlet Size inch (mm)
EDR-750	30 (206.84)	1 (25.4)	1 1/4 (31.75)
EDR-1000	60 (413.69)	3/4 (19.05)	1 (25.4)
	100 (689.48)	3/4 (19.05)	1 (25.4)
EDR-1500	125 (861.84)	3/4 (19.05)	1 (25.4)
	160 (1103.16)	3/4 (19.05)	1 (25.4)
EDR-2000	30 (206.84)	1 1/4 (31.75)	1 1/2 (38.1)
	60 (413.69)	1 (25.4)	1 1/4 (31.75)
	100 (689.48)	3/4 (19.05)	1 (25.4)
	125 (861.84)	3/4 (19.05)	1 (25.4)
	160 (1103.16)	3/4 (19.05)	1 (25.4)

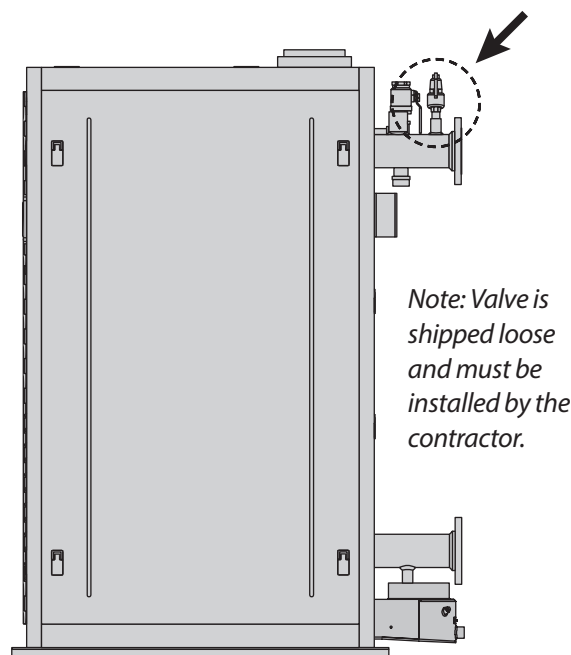

FIGURE 2 - SAFETY VALVE LOCATION

WARNING

All information in this manual is for reference and guidance purposes, and does not substitute for required professional training, conduct, and strict adherence to applicable jurisdictional/professional codes and regulations.

The discharge from the safety relief valve must be arranged to ensure no danger of scalding personnel, or equipment damage.

Provisions must be made to properly pipe the safety relief discharge away from the boiler to the point of discharge.

No shutoff of any kind shall be placed between the safety relief valve and the boiler, or in the discharge pipe between the valve and the atmosphere. Doing so may cause an explosion from overpressure.

The hydronic system should never be flushed while the boiler is attached to the system since the debris could accumulate in the boiler and block water from passing through the heat exchanger.

NOTE

The upper water connection on the back of the boiler is the outlet connection. The lower water connection on the rear of the boiler is the inlet connection.

Install Water Piping

All water supplies contain some solids, dissolved gases or dissolved minerals. These may cause corrosion, deposition and/or fouling of equipment. To prevent these contaminants from impacting boiler performance, valve operation and general pipe longevity, you must analyze and treat each installation uniquely.

Adhere to the following for water piping installation (see Figures 4 – 7):

- Manual isolation valves are recommended on both water connections for ease of service.
- Install piping so that the boiler is not supporting any piping load.
- Install manual purging valves in all loops and zones.
- Install a pressure-reducing (automatic fill) valve in the cold water fill line to the boiler system.
- To prevent scale and corrosion in boiler and associated piping, make up water must be kept to a minimum. This is best achieved by ensuring immediate repair of all leaks and maintaining system pressure.
- Check that the proposed operation of zone valves, zone circulator(s) and diverting valves will not isolate air separator(s) and/ or expansion tank(s) from the boiler.
- Provide at least 6 inches (152 mm) clearance from hot water pipes to combustibles.
- When used with a refrigeration system, install the boiler so that the chilled medium is piped in parallel with the boiler with appropriate valves to prevent the chilled medium from entering the boiler. If the boilers are connected to heating coils (located in air handling units) where they may be exposed to refrigerated air circulation, such boiler piping systems must be equipped with flow control valves or other automatic means to prevent gravity circulation of the boiler water during the cooling cycle.
- Include the following in the mechanical equipment in the hydronic heating system:
 - » *An automatic pressure activated water make up valve with back flow preventer. It must be set to maintain required Net Positive Suction Head (NPSH) for re-circulating pumps, a positive system pressure at the highest point of at least 5-10 PSIG, and should be designed to add water to the system at the outlet of the boiler but should not be fed directly into the boiler.*
 - » *Air removal equipment, including an air separator and automatic breather valves, along with a functioning expansion tank. Each must be designed to system specifications.*
- Install filtration in the common loop or per boiler to remove particulates if appropriate. A #4 or finer mesh size is required.

- Install bypass chemical feeder for corrosion inhibitor maintenance if appropriate.
- Install corrosion coupon holder to assess corrosion inhibitor performance if appropriate.
- Before installing an Endura boiler into a hydronic loop, be sure that the system piping and any other components of the system are clean and free of debris and any foreign matter. The hydronic system must be completely flushed prior to installing the boiler.

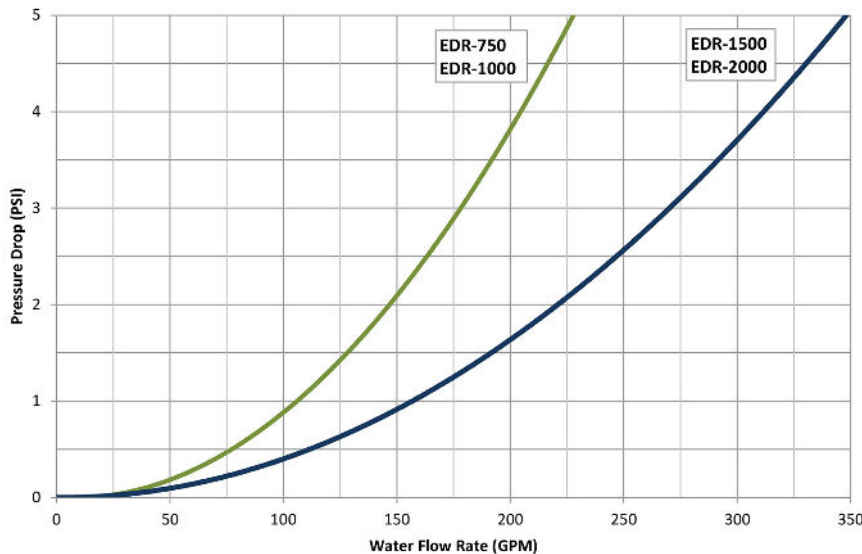

FIGURE 3 - TYPICAL WATER SIDE PRESSURE DROP

■ Variable Primary Piping Arrangement

Endura boilers are designed for installation in variable primary flow piping arrangements (see Figures 4 and 5), sometimes referred to as full flow systems. This arrangement eliminates temperature mixing associated with primary-secondary piping, thereby delivering the lowest temperature water directly to the boiler return connections and increasing thermal efficiency of the condensing boiler plant.

Adhere to the following for variable primary piping arrangements:

- Select secondary (system) pump(s) with sufficient total dynamic head for the pressure drop of the loop at design flow. See Figure 3 for the boiler water pressure drop. This boiler will automatically perform a safe shutdown in the event of a low flow condition; however, proper design flow is required to deliver heat to the users and prevent nuisance lockouts.
- Install a motorized isolation valve per boiler. This eliminates flow through idle boilers accordance with ASHRAE 90.1-2013 (6.5.4.3.2). Blending of unheated supply water impacts temperature control and can cause manual reset high temperature lockouts. Use only one motorized isolation valve per boiler; two-position type actuator, open or closed. It is acceptable to install the valve on either the inlet or the outlet piping of each boiler, but never both. Select a valve actuator with a cycle time of 45 seconds or less. Do not install modulating isolation valves on boiler piping.

⚠ WARNING

All information in this manual is for reference and guidance purposes, and does not substitute for required professional training, conduct, and strict adherence to applicable jurisdictional/professional codes and regulations.

Ensure all labels on the boiler are legible. All connections and safety devices, both mechanical and electrical, must be kept clean, with ease of access for inspection, use and maintenance.

Do not store or use gasoline or other flammable vapors and liquids or corrosive materials in the vicinity of this or any other appliances.

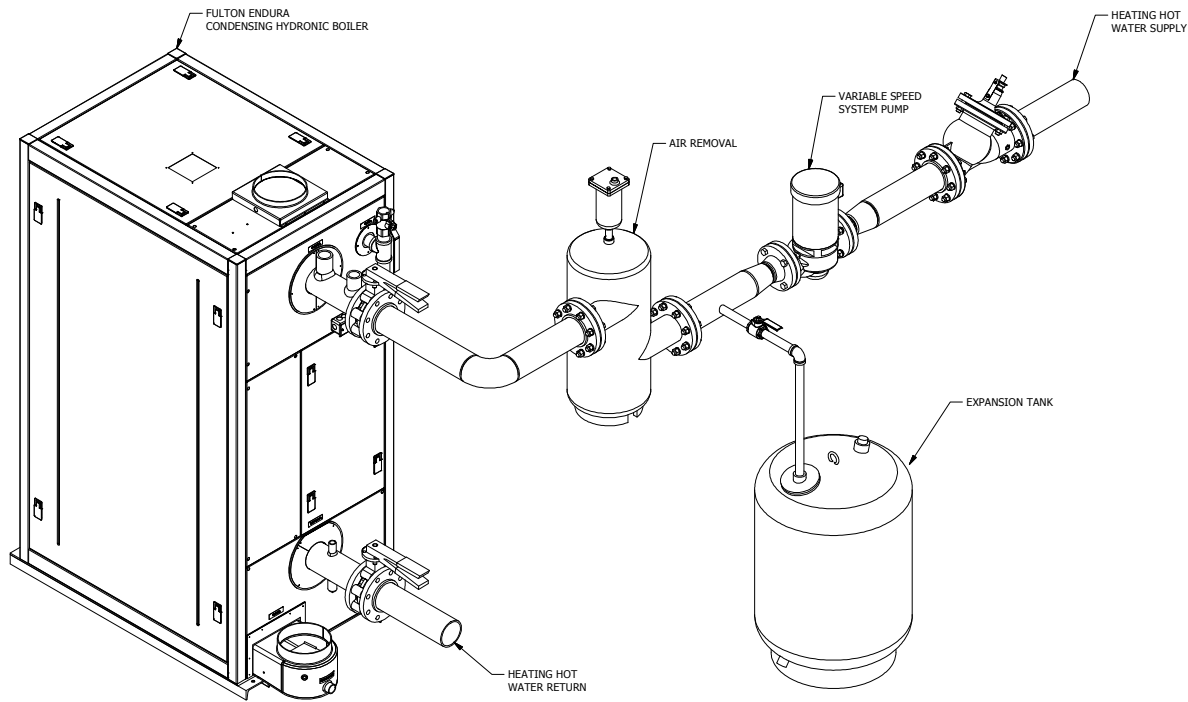

FIGURE 4 - SAMPLE PIPING LAYOUT, PRIMARY ONLY VARIABLE FLOW PIPING; SINGLE BOILER

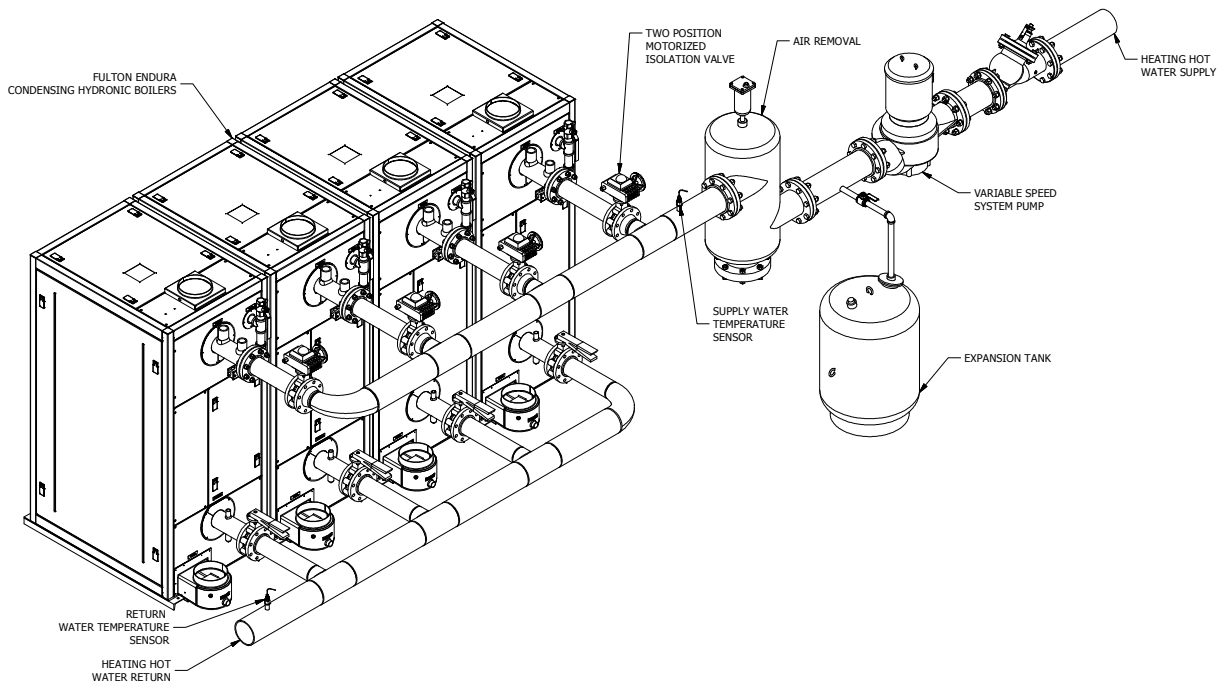

FIGURE 5 - SAMPLE PIPING LAYOUT, PRIMARY ONLY VARIABLE FLOW PIPING; MULTIPLE BOILERS

Note: Sample piping layout (P&ID) is a general representation of system installation. Good practice should be used in system design, including but not limited to adequate pipe/valve sizing and natural flow path for system water.

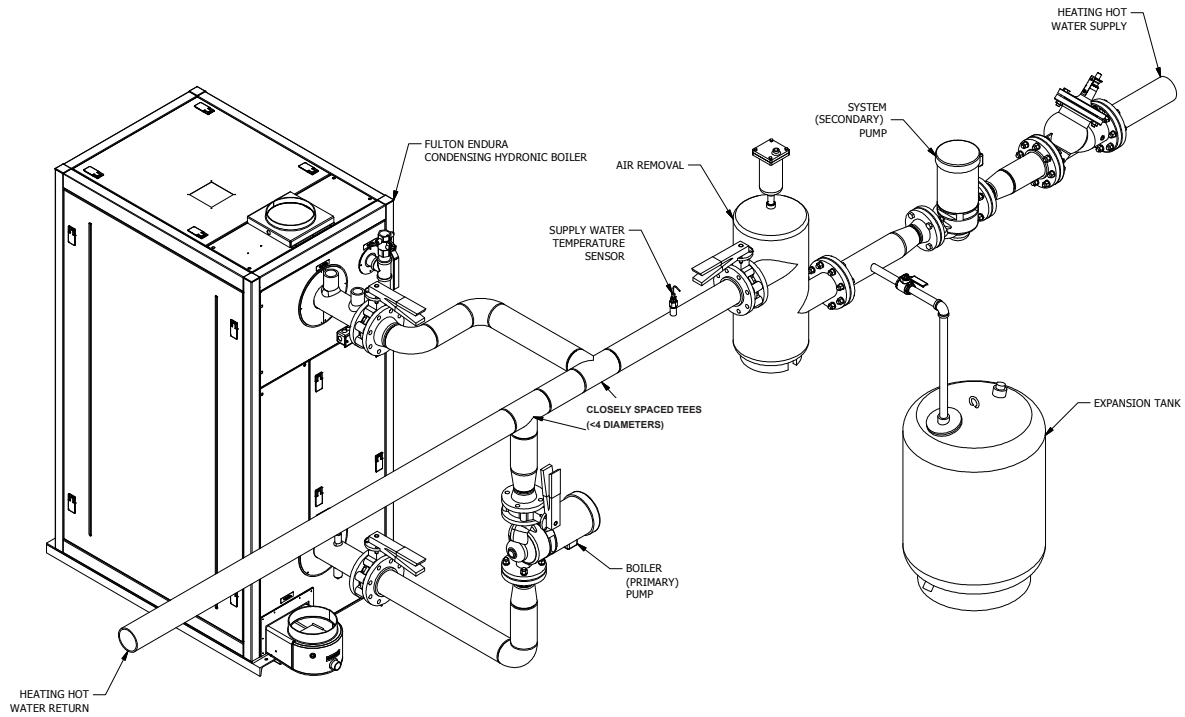

FIGURE 6 - SAMPLE PIPING LAYOUT, PRIMARY - SECONDARY PIPING; SINGLE BOILER

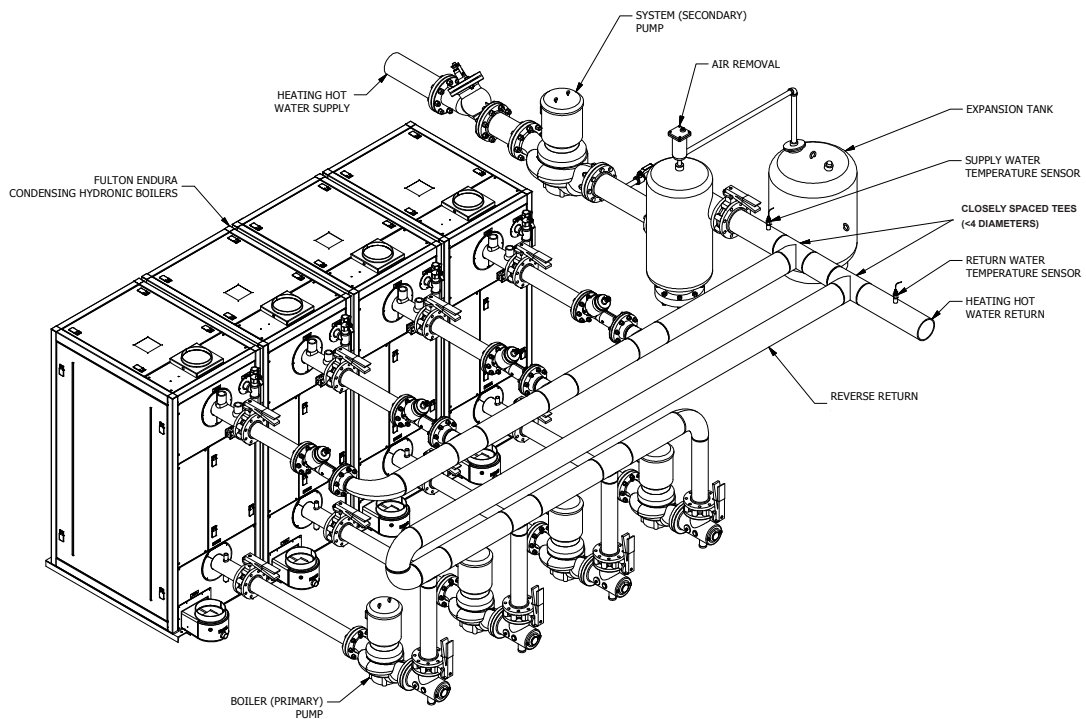

FIGURE 7 - SAMPLE PIPING LAYOUT, PRIMARY - SECONDARY PIPING; MULTIPLE BOILERS

Note: Sample piping layout (P&ID) is a general representation of system installation. Good practice should be used in system design, including but not limited to adequate pipe/valve sizing and natural flow path for system water.

WARNING

All information in this manual is for reference and guidance purposes, and does not substitute for required professional training, conduct, and strict adherence to applicable jurisdictional/professional codes and regulations.

Do not use matches, candles, flame or other sources of ignition to check for gas leaks.

- Ensure flow paths in the hydronic loop and residual heat in the pressure vessel is adequately dispersed for sufficient time after the burner is disabled. The valve control system must be capable of leaving the lead boiler valve open at all times.
- Use a reverse return header to balance flow across the boilers where reverse return cannot be used, it is recommended to install a balancing valve per boiler.
- Do not install three-way mixing valves or minimum temperature protection: This boiler does not have a minimum return water temperature requirement.
- Install system bypass valve(s) at or after the last coil(s), do not install bypass valves directly after the secondary (system) pump(s).

■ Primary-Secondary Piping Arrangement

It is acceptable to install this boiler in a primary-secondary arrangement, although this arrangement is not required. See Figures 6 and 7. Primary-secondary arrangements are used to decouple the water flow of the primary (boiler) loop from the secondary (system) loop. Blending occurs in the shared piping region.

Adhere to the following for primary-secondary piping arrangements:

- Typical decoupling methods include closely spaced tees, a buffer tank, or a hydraulic separator. Where using closely spaced tees, separate by four pipe diameters or less.
- Install the dedicated boiler circulator on the inlet side of the boiler, pumping into the return connection. Select pump(s) with sufficient total dynamic head for the pressure drop of the loop at design flow. See Figure 3 for the boiler water pressure drop.

In addition to the above, adhere to the following for multiple boiler systems:

- A check valve is required per boiler. Motorized isolation valves are not an acceptable substitute for check valves.
- Use a single common supply and a single common return connection into the secondary (system) piping. Do not use separate connections for each boiler into the secondary piping.
- Use a reverse return primary header to balance flow across the boilers. Where reverse return cannot be used, it is recommended to install a balancing valve per boiler.

Meet Water Chemistry Requirements

System water chemistry requirements are as follows:

- pH: Range of 8.5 - 10.5
- Oxygen: Less than 250 ppb (operating condition)
- Total Iron/Copper: Less than 5 ppm
- Corrosion Inhibitor: Capable of maintaining iron corrosion rates <2 mpy. Due to changing environmental restrictions a non-heavy metal ALL ORGANIC inhibitor is recommended which is designed for multi metal systems including ferrous metals and yellow metals such as copper and brass.
- Chloride: Less than 200 ppm
- Hardness: Less than 3.5 grains per gallon (60 ppm) in make-up/fill water. Calcium buildup on heating surfaces is not covered under warranty.

Adhere to the following:

1. Refer to your water conditioning or chemical treatment supplier for analysis and recommendations for proper system conditions.
2. Follow a program with appropriate monitoring and maintenance of system water conditions as provided by your water conditioning or chemical treatment supplier.
3. If RO/DI water is used as a source for hydronic loop water or makeup water, it must be neutralized to a pH of 8.5 - 10.5 prior to entering the boiler. Failure to neutralize the RO/DI water will void the pressure vessel warranty and may cause high general corrosion rates.
 - The system must have an automatic pH controller to monitor and log the levels. This must be independent of other chemical feed systems.
 - Makeup water pH range must be 7.5 - 8.8; the boiler water must be maintained within pH range of 8.5 - 10.5.
4. Operate the boiler in a closed-loop system using water or water/glycol (not requiring a make-up water supply). A large amount of improperly treated make-up water can cause premature failure of the heat exchanger resulting from scale build up. Scale build up will reduce the efficiency and useful life of the boiler and is not covered under warranty.
5. For freeze protection, an inhibited propylene glycol is recommended. The maximum concentration is 50% glycol by volume. Only use mixtures formulated for hydronic systems. DOWFROST™ HD is recommended. Do not use automotive glycol.
6. At a minimum, the hydronic fluid should be checked for glycol concentration and pH once a year, or per glycol manufacturer schedule. A refractometer is recommended.



WARNING

All information in this manual is for reference and guidance purposes, and does not substitute for required professional training, conduct, and strict adherence to applicable jurisdictional/professional codes and regulations.

If the water supply must be temporarily disconnected from the condensate drain trap, the boilers must be turned off to prevent accidental flue gas emission into the boiler room.



CAUTION

Some soap used for leak testing is corrosive to certain types of metals. Clean all piping thoroughly after completing the leak check.

Proper water filtration and treatment are essential to ensure the longevity and efficiency of the boiler. Failure to adhere to water quality requirements will reduce the useful life of any boiler. Water side damage or failure of the heat exchanger is not covered under warranty. This includes but is not limited to damage from particulates, foreign matter, debris, excess oxygen, glycol degradation, fouling, scale buildup, and corrosion.

If the piping system attached to this unit will be chemically cleaned, the boiler must be disconnected from the system and a bypass installed so that the chemical cleaning solution does not circulate through the boiler. If cleaning is desired, flush the boiler with clean domestic water only.

■ Prevent Oxygen Contamination

There are several ways to prevent boiler water oxygen contamination:

- Minimize system leaks to minimize make up water requirement.
- Do not use open tanks or fittings.
- Do not use oxygen permeable materials anywhere in the water system.
- Repair leaks in the system quickly.
- Eliminate fittings wherever possible.
- Use air elimination devices in system piping.

■ Eliminate System Air

► *NOTE: There are no built-in boiler air eliminating features.*

Adhere to the following for air elimination:

1. The installation of an air separator and air eliminator (air vent) is required.
2. To prevent scale corrosion in boiler and associated piping, make up water must be kept to a minimum. This is best achieved by ensuring immediate repair of all leaks and that system pressure is maintained.
3. If a sealed diaphragm-type expansion tank is used, install an air eliminator in the hot water piping at the air separator on the suction side of the system circulator(s).
4. If an air cushion type expansion tank is used, pipe tank directly into boiler supply on the suction side of the system circulator(s).
5. On multi-zoned systems (or a system with both space and domestic water heating), air elimination must be provided either in the common piping or on every loop.
6. When the boiler is installed at a higher level than baseboard radiation (if used), air elimination must be provided directly above the unit.

Fill the Boiler With Water

To be sure that the boiler is not air-bound, open the pressure-relief valve located at the rear of the boiler. Leave the relief valve open until a steady flow of water is observed. Close the valve and finish filling the system.

Gas Supply Piping

This boiler features a gas fired fully modulating burner requiring gas delivery at a relatively constant pressure and calorific content. This ensures efficient and reliable combustion. Do not modify the gas train.

The gas train (See Figure 8) pressure requirements are detailed on the boiler data plate, located at the rear of the boiler.

This boiler is factory test fired and combustion is adjusted per the factory Test Fire Report.

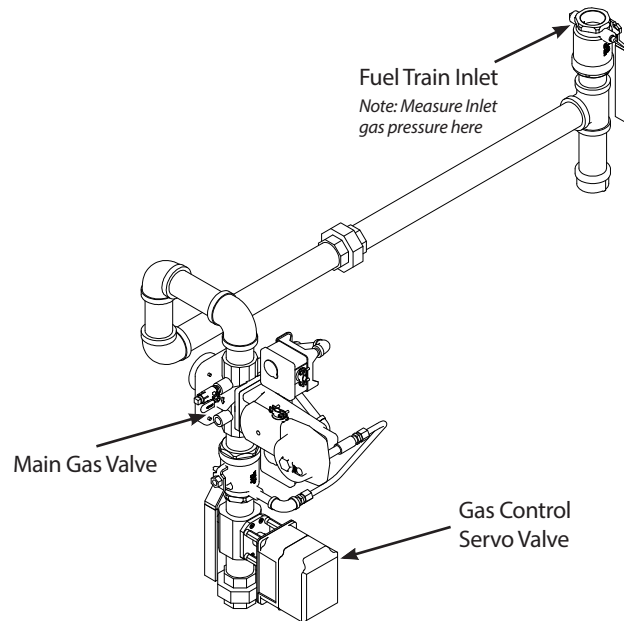

FIGURE 8 - TYPICAL GAS TRAIN
(VARIES BY SIZE/MODEL)

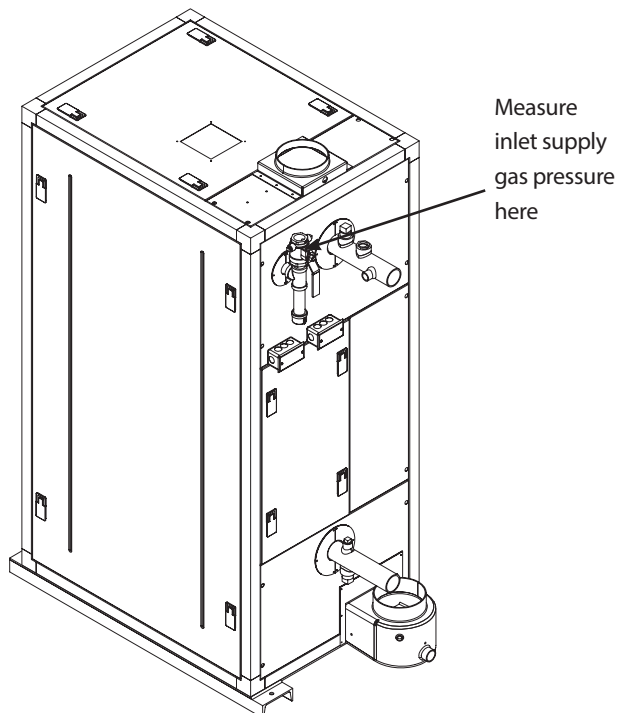

FIGURE 9 - MEASURING INLET GAS PRESSURE

■ Inlet Gas Pressure

Adhere to the following:

- Static inlet gas pressure: Measure while boiler is idle. Verify pressure is within allowable range.
- Dynamic inlet gas pressure: Measure while boiler is in operation at maximum firing rate. Verify pressure is within allowable range.
- The gas delivery system must provide a stable and consistent pressure across the entire turndown range, including light off and idle conditions.
- Maximum inlet gas pressure drop from static to dynamic must not exceed 15%, or the maximum allowable by local code (CSA B149 clause 6.3.2 for Canada). The stricter of the two shall apply.

■ Gas Pressure Requirements

The minimum gas pressure required is 4"W.C. For gas pressures exceeding 28"W.C. (14"W.C. Canada), a step down regulator (not supplied) must be installed in the gas supply piping.

■ Line Gas Pressure Regulation

When inlet gas pressure exceeds 28"W.C. (14"W.C. Canada), a line gas pressure regulator is required to step the gas pressure down below maximum pressure.

Proper selection and installation of a gas pressure regulator is essential in providing conditions for efficient and reliable combustion. Adhere to the following guidelines when selecting and installing a gas pressure regulator:

- A line pressure regulator listed and labeled to ANSI Z21.80/CSA 6.22 is recommended. Lock-up is defined as an outlet pressure not more than 150% or 5" W.C., whichever is greater, above the setpoint after a downstream safety shutoff valve closes within 2 seconds. Appliance regulators are not a substitution for line gas pressure regulators and must not be used.
- A gas pressure relief valve may be required for overpressure protection, refer to the local code(s) adopted by the AHJ.
- A sediment trap is recommended prior to the inlet of the regulator.
- If the level of pipe system cleanliness is unacceptable or unknown, it is recommended that a gas filter be installed prior to the regulator.
- On the outlet of the regulator: Install a straight and uninterrupted section of pipe matching regulator connection size with a minimum length of 10 pipe diameters prior to any valves or fittings.
- When installed in close proximity to an appliance, some regulators may experience oscillation (hunting) or an outlet pressure spike when demand ends. Provide adequate volume by locating the regulator a recommended minimum of 10 total linear feet of pipe from boiler fuel train inlet. Consult the regulator manufacturer for installation requirements.
- The body size should never be larger than the pipe size. However, a properly sized regulator may be smaller than the pipe size.
- The inlet pressure used for sizing should be measured directly at the regulator inlet. Measurements taken at any other point may be subject to losses associated with upstream piping.
- Consult the regulator manufacturer for orifice selection.
- If two or more springs are available for a particular outlet pressure in the desired range use the spring with the lower range for better accuracy.

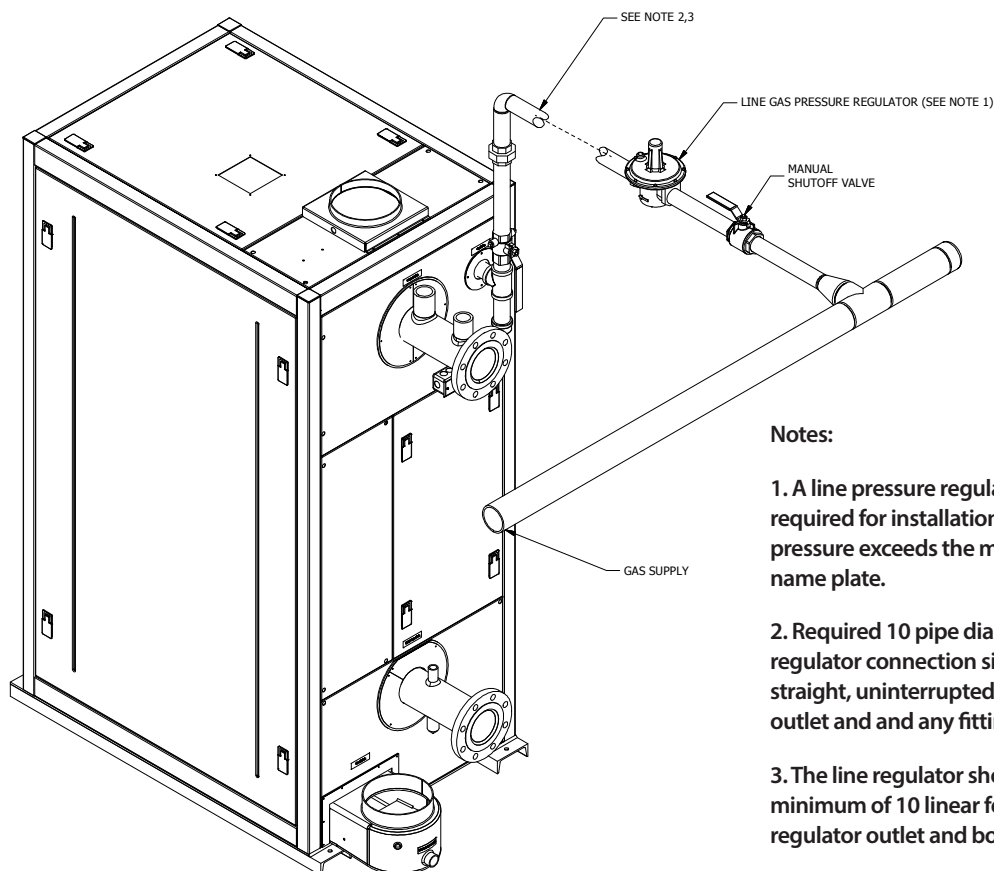

FIGURE 10 - ENDURA SINGLE BOILER GAS SUPPLY PIPING

- For multiple boiler installations it is recommended that an individual line gas pressure regulator be used to step-down the gas pressure at each boiler. Where a single regulator is used for multiple boilers the regulator must be appropriate for the entire gas delivery turndown range. This includes all boilers on at full fire to one boiler on at low fire (see Figure 12).

Gas Piping Installation

Field gas piping must be installed in accordance with NFPA 54 National Fuel Gas Code, ANSI Z223.1, and any other local codes which may apply. Adhere to the following for gas piping installation:

1. See Table 3 for required natural gas pipe size, based on overall length of pipe from the meter plus equivalent length of all fittings. Approximate sizing may be based on 1,020 BTU for 1 cubic foot of natural gas. See Figures 6 and 7 for piping arrangements.
2. Piping must be of the proper size to ensure adequate gas supply. It is typical for gas delivery piping to be up-sized one or several diameters larger than boiler gas inlet size.

Notes:

1. A line pressure regulator (not provided) is required for installations where the supply gas pressure exceeds the maximum on the boiler name plate.
2. Required 10 pipe diameters equivalent to the regulator connection size. This pipe must be straight, uninterrupted pipe between regulator outlet and any fittings, valves, or elbows.
3. The line regulator should be installed with a minimum of 10 linear feet of pipe between the regulator outlet and boiler fuel train inlet.

3. The pipe and the fittings used must be new and free of dirt or other deposits.
4. When making gas-piping joints, use a sealing compound resistant to the fuel gas serving the boiler.
5. Install a manual gas shutoff valve and union (not supplied) prior to the boiler.
6. Piping must be installed such that no piping stresses are transmitted to the boiler. The boiler cannot be used as a pipe anchor.
7. All gas piping connections must be pressure-tested and checked for leaks before being placed into service. Test with compressed air or inert gas if possible.
8. The boiler gas train must be disconnected at the boiler manual shutoff valve from the gas supply piping system during any pressure testing of the system at pressures in excess of 1.0 psig (28 inch W.C.).

TABLE 3 - SCH 40 PIPE NATURAL GAS CAPACITY

Nominal Pipe Size	ID	Equivalent Pipe Length		Max Capacity in ft ³ of natural gas per hour. 14"wc pressure. Pressure drop of 0.5"wc. Equivalent length of pipe (feet)						
		90 Elb Feet (meter)	Tee Feet (meter)	20	40	60	80	100	150	200
1-1/4 (31.75)	1.380 (35.05)	3.45 (1.05)	6.9 (2.10)	950	-----	-----	-----	-----	-----	-----
1-1/2 (38.1)	1.610 (40.89)	4.02 (1.22)	8.04 (2.45)	1460	990	810	-----	-----	-----	-----
2 (50.8)	2.067 (52.50)	5.17 (1.57)	10.3 (3.13)	2750	1900	1520	1300	1150	950	800
2-1/2 (63.5)	2.469 (62.71)	6.16 (1.87)	12.3 (3.74)	4350	3000	2400	2050	1850	1500	1280
3 (76.2)	3.068 (77.92)	7.67 (2.33)	15.3 (4.66)	7700	5300	4300	3700	3250	2650	2280
4 (101.6)	4.026 (102.26)	10.10 (3.07)	20.2 (6.15)	15800	10900	8800	7500	6700	5500	4600
6 (152.4)	6.07 (154.17)	10.10 (3.07)	23.60 (7.19)	-----	-----	-----	-----	20220	16503	12766
8 (203.2)	7.98 (202.69)	13.30 (4.05)	29.10 (8.86)	-----	-----	-----	-----	41200	33660	29128

9. After completing pressure testing and obtaining any necessary approvals from the AHJ, introduce gas service and purge gas piping in accordance with local codes. Do not purge their contents into a confined space or where fuel gas can accumulate.
10. The boiler gas train has been factory leak tested however, fittings may loosen during shipment and installation. After gas piping is completed and before wiring installation is started, all piping connections (factory and field) must be carefully checked for gas leaks.. Use a soap and water solution or combustible gas detector. A GAS-Mate® 0119 or equivalent is recommended.
 - Each component must have a separate vent line to the outdoors. Vent lines must not be manifolded or combined with any other vent or exhaust systems.
 - Start with the vent connection size and as soon as it is practical, increase the pipe size one diameter. For every ten feet of vent, increase the pipe size one diameter. Never reduce the vent size.
 - Protect the vent termination from debris, dust and insects. Install the vent termination above the snow line and point down to prevent ingress of water. The termination must be a minimum of 3 ft (0.9 m) from a source of ignition.

Components Requiring Ventilation to the Outdoors

The SKP25 regulating gas valve has independent certification as a ventless regulator and does not require ventilation to the outdoors. The port marked "AIR" on the actuator is not a gas vent connection, connecting a vent line to this port may cause operational issues.

An authority having jurisdiction (AHJ) may not permit the use of a vent limiter on some or all components. If venting is required, use the following general guidelines:

- Drill an appropriately sized penetration for each vent line through the topmost panel on the rear of the boiler cabinet (Figure 11). Do not install any vent lines through removable latching panels. Properly seal around the pipe with silicone to maintain a sealed cabinet and ensure combustion air will not bypass the filter.

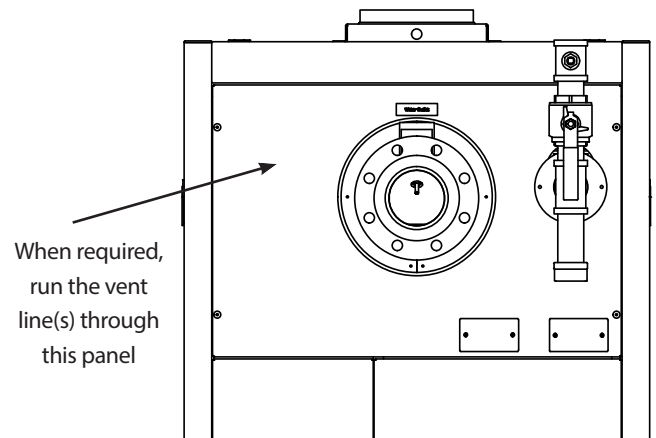
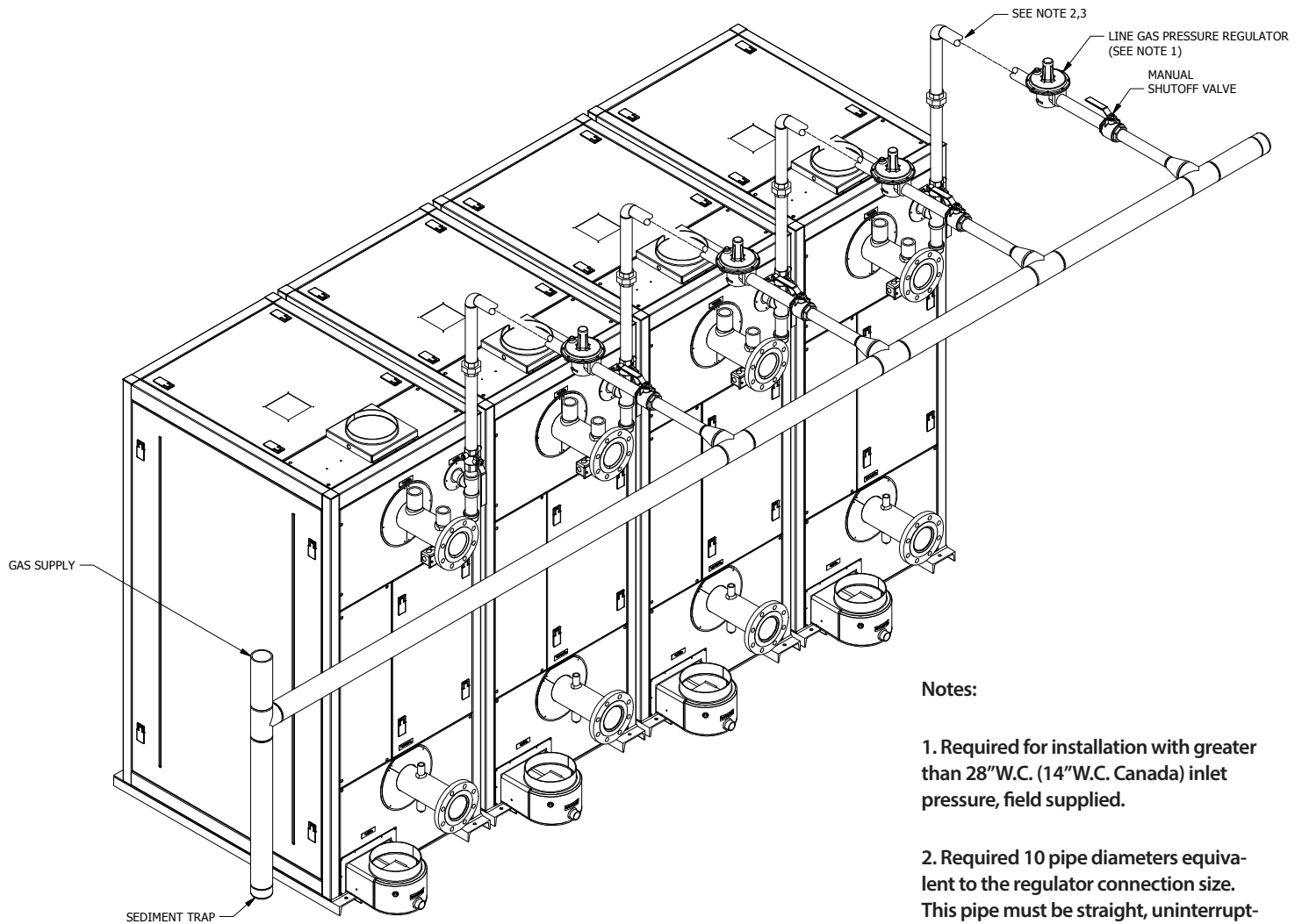

FIGURE 11 - TOPMOST REAR PANEL



Notes:

1. Required for installation with greater than 28" W.C. (14" W.C. Canada) inlet pressure, field supplied.
2. Required 10 pipe diameters equivalent to the regulator connection size. This pipe must be straight, uninterrupted pipe between regulator outlet and any fittings, valves, or elbows.
3. The line regulator should be installed with a minimum of 10 linear feet of pipe between the regulator outlet and boiler fuel train inlet.

FIGURE 12 - ENDURA MULTIPLE BOILER GAS SUPPLY PIPING

Install Condensate Drain Trap

A condensate drain trap is intended for use with the Fulton Endura boiler.

■ Single Boiler Drain Trap

The single boiler condensate drain trap is Fulton Part Number 4-57-005500. The drain trap must be configured one per boiler, with a maximum of 4,000,000 mm BTU total. (See Figures 13 and 15).

Adhere to the following for installation:

1. The 1 inch (25.4 mm) condensate drain will be reduced and connected to the 3/4 inch (19.05 mm) inlet on the base of the drain trap.
2. A condensate collecting tank and condensate pump will be required if a floor drain is not available to collect condensate (collecting tank and pump are not supplied with the boiler).
3. All piping (Figure 13) must be CPVC, galvanized, or stainless steel, and be free of leaks. Copper, carbon steel/iron pipe, or PVC are not acceptable.
4. The drain trap must be installed below the boiler condensate drain outlet.
5. Connect the 3/4 inch (19.05 mm) trap outlet to an appropriate waste line following applicable codes. The 3/4 inch (19.05 mm) drain connection on the drain tank must be the highest point prior to going to the drain. Failure to keep drain piping lower than this point will result in overflow of the drain tank. Slope the drain pipe away at a minimum pitch of 1 inch (25.4 mm) for every 12 feet (3.65 m).

► *NOTE: Ensure piping will not be exposed to freezing temperatures.*

■ Multiple Boilers Sharing A Common Drain Trap

The multiple boiler condensate drain trap is Fulton Part Number 4-57-000440. The maximum number of units to attach per condensate drain trap is 12,000,000 BTU total. (See Figures 14 and 16).

Adhere to the following for installation:

1. The boiler 1 inch (25.4 mm) condensate drain will be connected to the 1 inch (25.4 mm) inlet on the drain trap. One or more drain lines may be connected to this inlet (max of 12 MM BTU per drain).
2. If the water supply must be temporarily disconnected, the boilers must be turned off to prevent accidental flue gas emission into the boiler room.
3. The condensate drain cover must be kept on at all times, except during maintenance of the drain. This drain should be checked regularly in your boiler maintenance schedule.
4. A condensate collecting tank and condensate pump will be required if a floor drain is not available to collect condensate (collecting tank and pump are not supplied with the boiler.)
5. All piping (Figure 14) must be CPVC, galvanized, or stainless steel, and be free of leaks. Copper, carbon steel/iron pipe or PVC are not acceptable.
6. Connect 1 inch (25.4 mm) condensate drain(s) (at the rear of the boiler), to the 1 inch (25.4 mm) inlet at the base of the drain tank. The header must be below the condensate outlet of the boiler, and must remain flooded during operation.
7. Connect the 1.5 inch (38.1 mm) drain outlet to an appropriate waste line following applicable codes. The 1.5 inch (38.1 mm) drain connection on the drain tank must be the highest point prior to going to the drain. Failure to keep drain piping lower than this point will result in overflow of the drain tank. Slope the drain pipe away at a minimum pitch of 1 inch (25.4 mm) for every 12 feet (3.65 m).
8. Attach a 1/4" water supply to the compression fitting on the float. The water line must be connected to an uninterruptible supply. Fulton recommends connecting it before the "fast fill" valve to the boiler supply but after the back flow preventer to avoid contamination of a potable water supply. Maximum allowable water pressure to the compression fitting is 100 PSI (689.5 kPa).

► *NOTE: Ensure piping will not be exposed to freezing temperatures.*

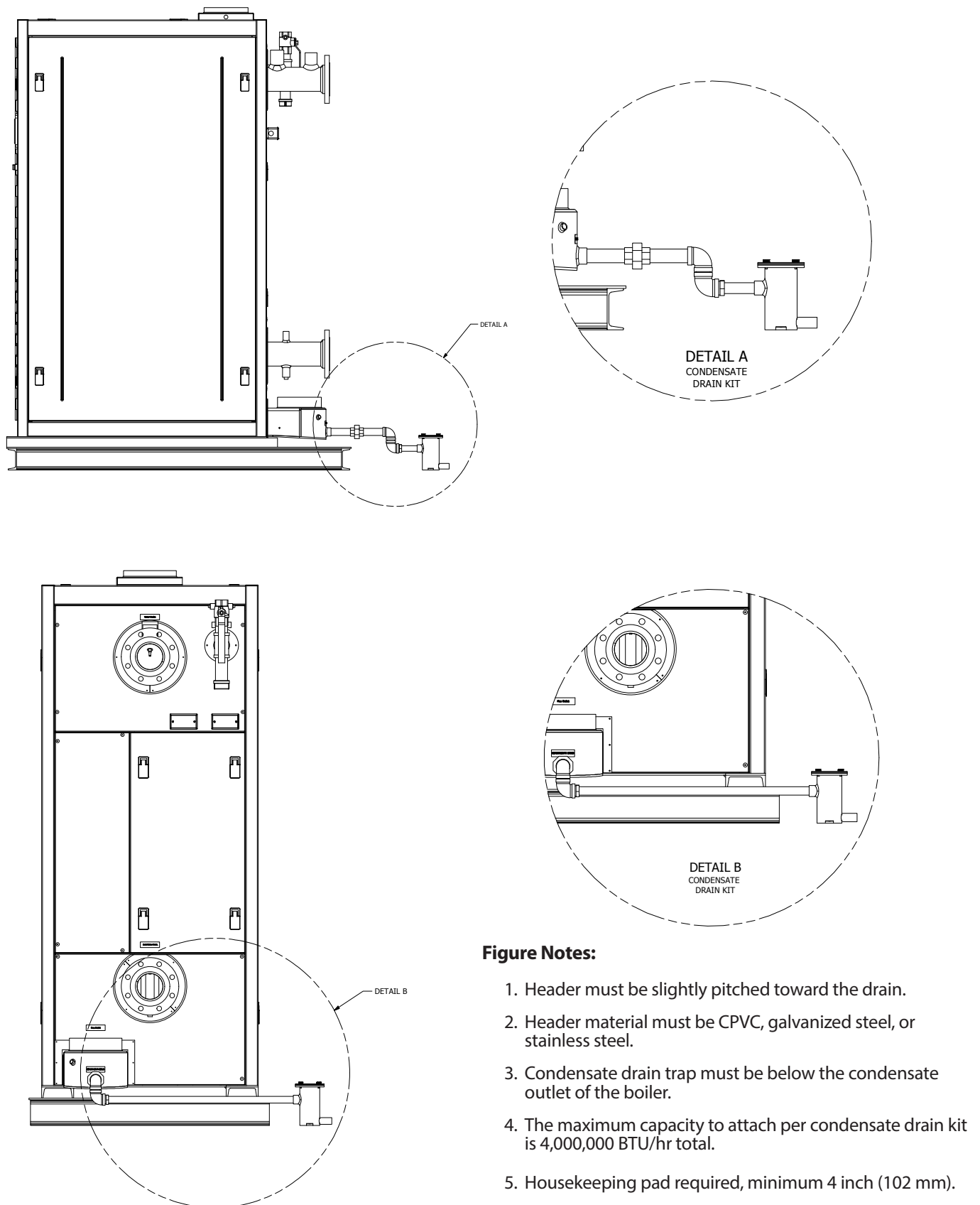

FIGURE 13 - CONDENSATE DRAIN PIPING FOR INDIVIDUAL ENDURA BOILER

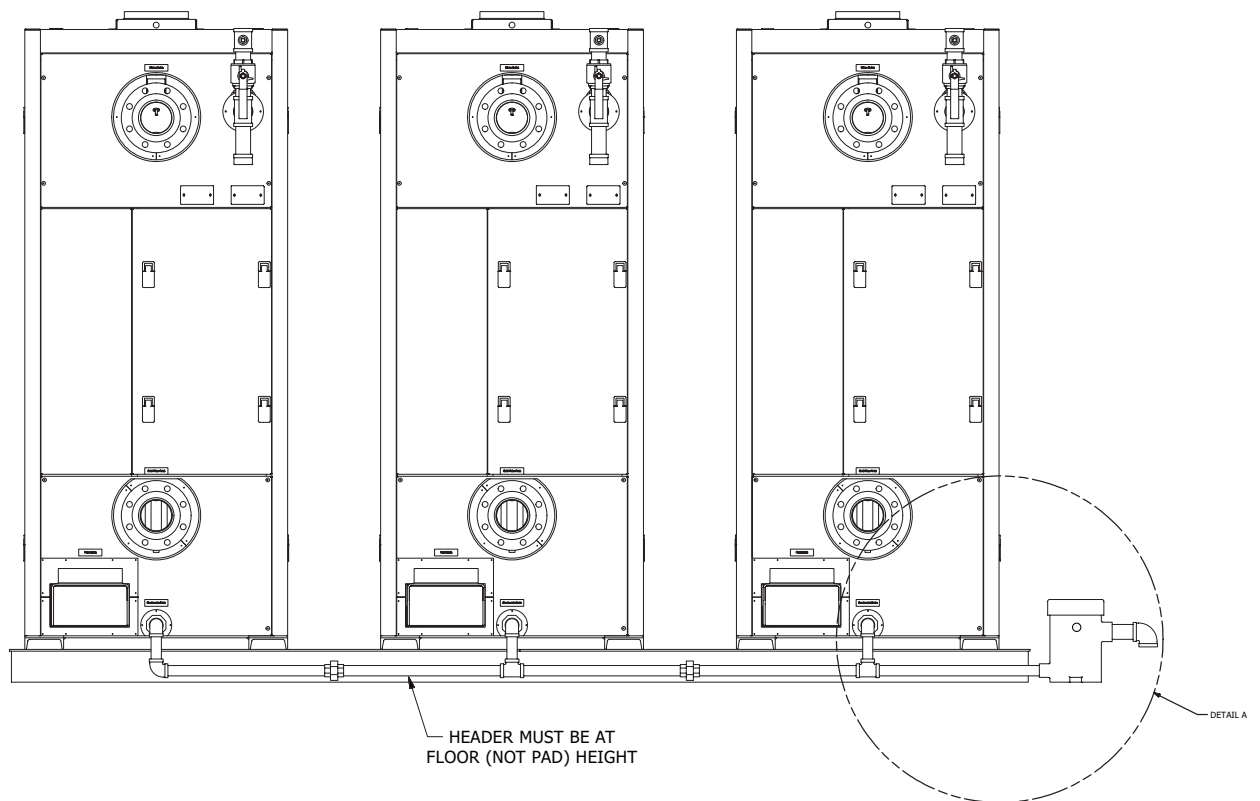

Figure Notes:

1. Header must be slightly pitched toward the drain.
2. Header material must be CPVC, galvanized steel, or stainless steel.
3. Header should be taken to the lowest point possible and remain flooded during operation.
4. The condensate drain trap outlet must be below the condensate outlet if the boiler.
5. For multiple boiler installation, maintain minimum pipe size of one inch (25.4 mm) for the header piping.
6. The maximum capacity to attach per multiple boiler condensate drain trap is 12,000,000 BTU/hr total.
7. Housekeeping pad required, minimum 4 inch (102 mm).

0.25" (U.S.) tapping provided for water connection to maintain water seal.

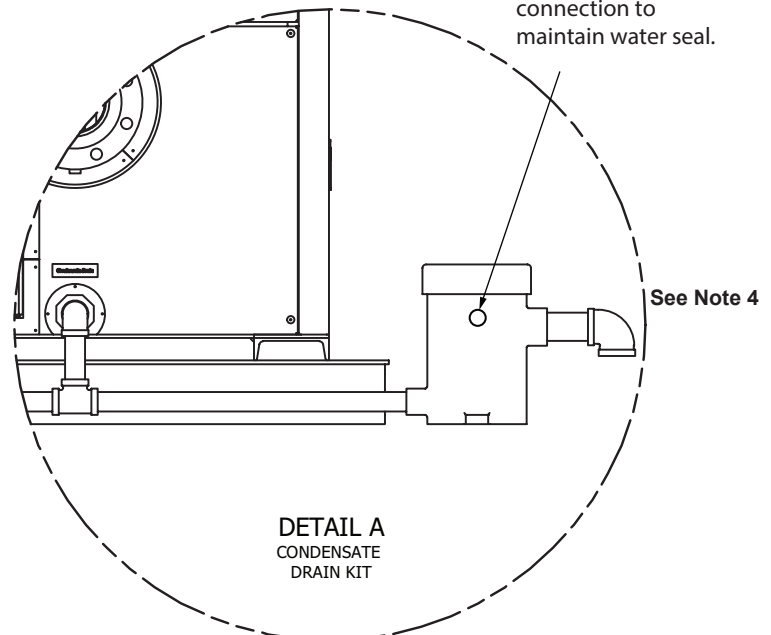

FIGURE 14 - CONDENSATE DRAIN PIPING FOR MULTIPLE ENDURA BOILERS

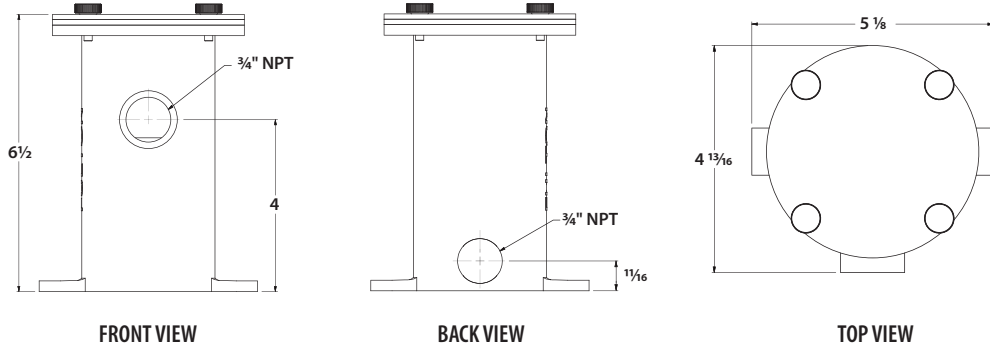

FIGURE 15 - SINGLE BOILER CONDENSATE DRAIN TRAP

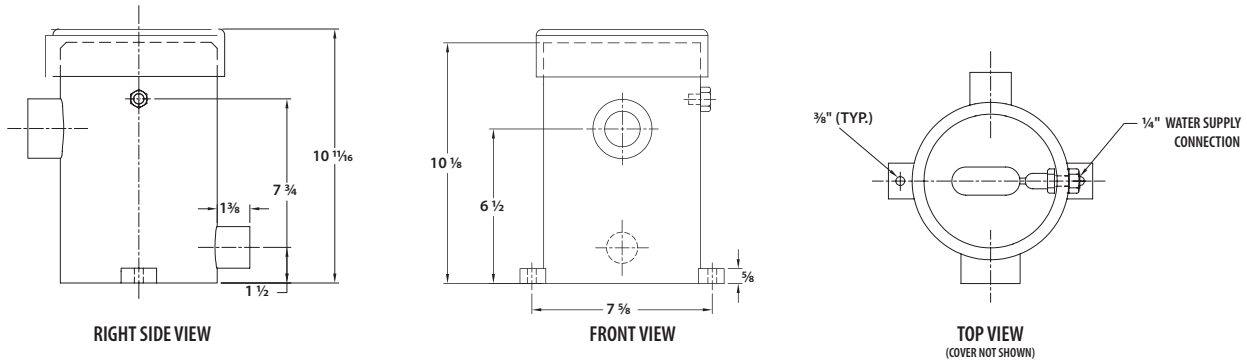

FIGURE 16 - MULTIPLE BOILER CONDENSATE DRAIN TRAP

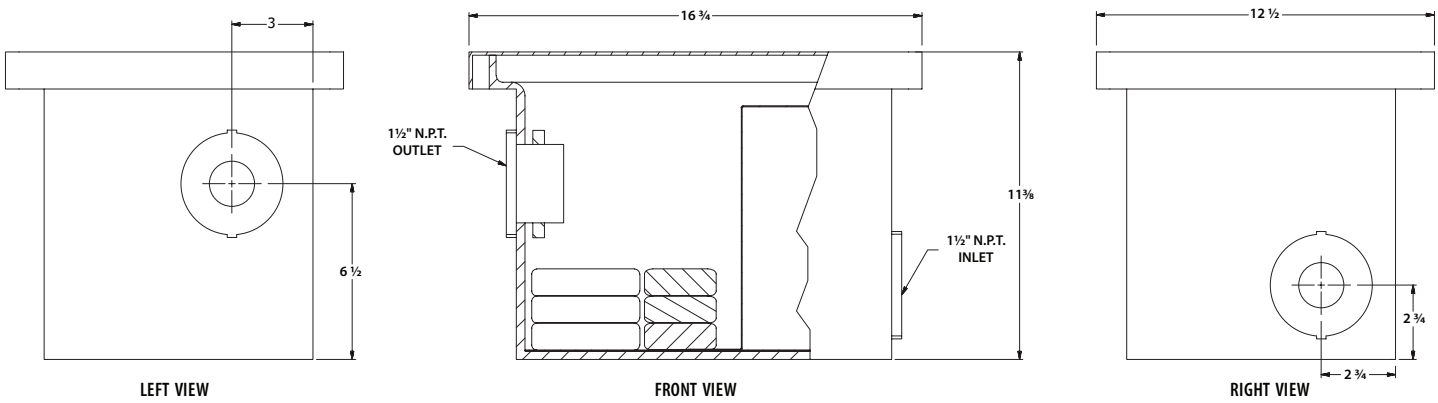

FIGURE 17 - FULTON PH NEUTRALIZING KIT

Install pH Neutralization Kit

The pH Neutralization Kit is a Fulton-provided kit designed to bring the pH level of the boiler’s condensate to a more neutral level. It is not a replacement or alternative for the Condensate Drain Trap. See Figures 17 and 18.

Adhere to the following for pH Kit installation:

1. Use CPVC, stainless, or galvanized pipe and fittings to connect condensate trap to kit.

2. Connect kit downstream of Condensate Drain Trap. See Figure 18.
3. Pipe outlet to appropriate drain. It is acceptable to use PVC or CPVC on the outlet to drain.
4. Check condensate pH periodically.

► **NOTE:** Replacement bags are available from your Fulton local representative. The medium in the container will neutralize the condensate up to 12,000,000 BTU/hr for approximately 6 months. (Fulton Part No. [2-30-001580](#))

MULTIPLE BOILER ASSEMBLY

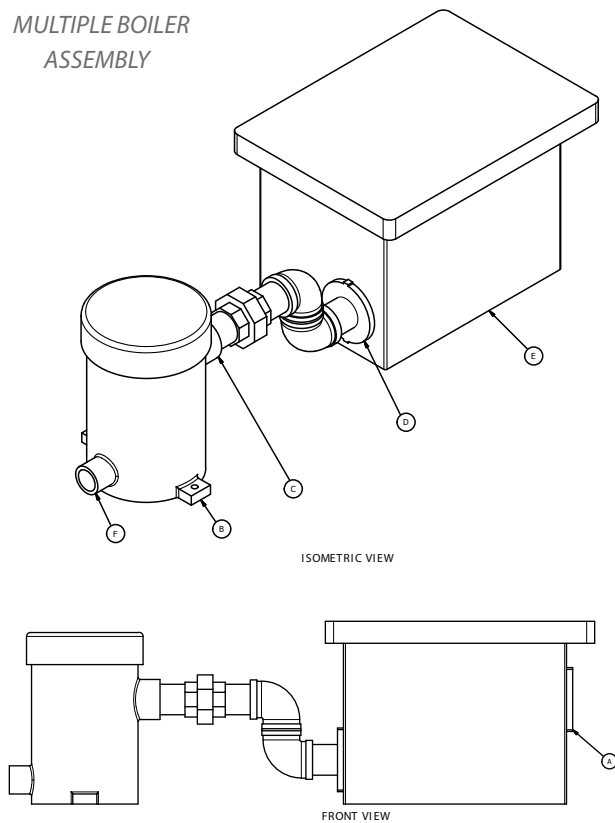

SINGLE BOILER ASSEMBLY

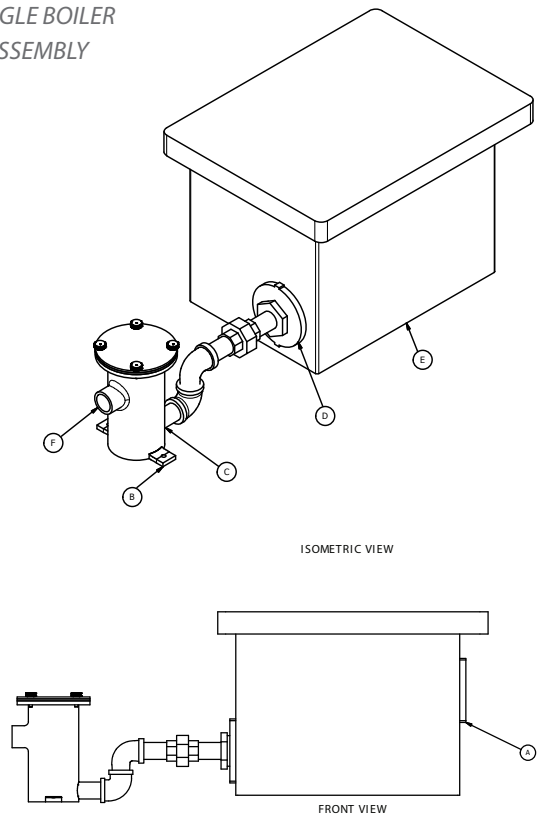

	Multiple Boilers	Individual Boiler
(A) pH Kit Outlet	1 1/2"	1 1/2"
(B) Condensate Drain Trap	4-57-000440	4-57-005500
(C) Drain Outlet	1 1/2"	3/4"
(D) pH Kit Inlet	1 1/2"	1 1/2"
(E) pH Neutralization Kit	4-50-000008	4-50-000008
(F) Drain Inlet	1"	3/4"
Neutralizing Media	2-30-001580	2-30-001580

FIGURE 18 - FIELD CONNECTIONS FOR CONDENSATE DRAIN TO PH NEUTRALIZATION TANK

WARNING

All information in this manual is for reference and guidance purposes, and does not substitute for required professional training, conduct, and strict adherence to applicable jurisdictional/professional codes and regulations.

CAUTION

Ensure there is not a negative pressure in the boiler room. The boiler room pressure must be neutral relative to the outdoors.

Particulate matter or chemicals (example: chlorine, fluorine, perchlorethylene, halogenated compounds) in the combustion air supply to the boiler will cause damage or failure to the burner. High-risk situations for particulate matter to be in the air include construction and maintenance activities. See Table 5.

Venting Requirements

TABLE 4 - GENERAL VENTING PRESSURE REQUIREMENTS

<p>Maximum Combined Pressure Loss: Net total absolute values of friction losses ("delta-p") of both the combustion air intake duct (if used) and flue gas exhaust vent systems must not exceed this value.</p>	1.50 "W.C.
<p>Maximum Negative Draft: The stack effect (draft, negative vent pressure) as measured at the boiler flue gas outlet relative to the room pressure must not exceed this value.</p>	- 0.04 "W.C.
<p>Typical Maximum Equivalent Length (CAI): Approximate maximum equivalent length of the combustion air intake (CAI) system. Equivalent lengths can vary by manufacturer, material, installation methods and site conditions. Consult your vent supplier for more details.</p>	100 feet
<p>Typical Maximum Equivalent Length (Flue Gas Vent): Approximate total maximum equivalent length of the flue gas vent system. Equivalent lengths can vary by manufacturer, material, installation methods and site conditions. Consult your vent supplier for more details.</p>	100 feet
<p>Mechanical Room Pressure: Ensure there is not a negative pressure in the boiler room. For safe and reliable operation, the mechanical space ventilation system should maintain a neutral pressure relative to the outdoors.</p>	0.0 "W.C.

Adhere to the following venting requirements:

1. This boiler can operate to the combined intake and flue exhaust pressure drops without altering standard capacities: See Table 4.
2. The combined venting system draft pressure readings at the boiler exhaust connection and air intake connection cannot exceed the maximum values stated in Table 4; and must remain relatively stable throughout all operating conditions, including the ignition sequence.

► *NOTE: Venting pressure is the combined result of frictional pressure drop and natural draft (stack effect) in the combustion air intake piping (if used) and flue gas exhaust system.*

3. Drastic draft changes during operation may result in the generation of excessive carbon monoxide or soot, which may affect operational reliability and condition of burner, ignition assembly, or other combustion system components leading to increased maintenance or replacement of these items.
4. The equivalent length method is not a substitution for good engineering practices for determining acceptability of a vent system due to varying burner modulation rates, ambient air temperatures, and flue gas temperatures, among other factors. Combustion air intake piping (if used) must be accounted for in an analysis of the venting system.
5. If the maximum positive pressure loss is exceeded, the boiler may have to be de-rated or require the installation of draft accessories such as an engineered exhaust assist fan to prevent operational issues from

occurring. If the maximum negative pressure is exceeded due to excessive natural draft (stack effect), the exhaust system may require the use of draft accessories such as a fixed-position balancing baffle or modulating overdraft damper. Draft accessories must be appropriate for Category II/IV installations and are not included with the boiler. Consult your venting supplier for recommendations.

6. Adhere to local and jurisdictional codes and regulations, which may differ from recommendations and diagrams contained in this manual.
7. Site specific conditions not addressed in this manual may require additional precautions or design considerations. Consult your local Fulton Representative and venting supplier for recommendations.

► **NOTE:** Consult your venting pipe supplier for assistance with sizing of vent materials and other potentially required accessories.

8. The layout of the piping used for air intake and exhaust must be done in a way that facilitates smooth travel and natural flow.
9. A pressure drop calculation is an acceptable method for evaluating theoretical draft, but is not enough information to fully validate combustion air intake and flue gas exhaust vent systems. The designer and installer must use good practice and remain cognizant of important factors that cannot be captured by a pressure drop calculation such as local code requirements, accessibility for inspection and maintenance, aesthetic concerns, flue gas recirculation, stagnant vapor plumes, prevailing wind direction, nearby mechanical equipment and other design considerations as detailed in this manual. Some recommendations:
 - Avoid sharp turns, boot tees, bullhead tees, back-to-back 90 degree elbows, and short radius elbows.
 - Avoid extensive direction changes (flue gases being required to turn around).
 - Never direct flue stacks in a downward direction.

Combustion Air Intake

Adhere to the following for installation:

1. It is the responsibility of the designer and installer of the venting system to guarantee the prevention of flue gas recirculation (flue gases being drawn into a boiler's combustion air supply, or flue gases moving backward through an idle boiler).
2. The installation of room exhaust fans in a boiler room should be avoided. An exhaust fan or similar equipment can create down draft in the stack or restrict the burner's air supply, resulting in poor combustion or life safety hazard.
3. It is essential that only fresh air is allowed to enter the combustion air system. Foreign substances, such as combustible volatiles in the combustion system can create hazardous conditions.



WARNING

All information in this manual is for reference and guidance purposes, and does not substitute for required professional training, conduct, and strict adherence to applicable jurisdictional/professional codes and regulations.



CAUTION

Ensure there is not a negative pressure in the boiler room. The boiler room pressure must be neutral relative to the outdoors.

Particulate matter or chemicals (example: chlorine, fluorine, perchlorethylene, halogenated compounds) in the combustion air supply to the boiler will cause damage or failure to the burner. High-risk situations for particulate matter to be in the air include construction and maintenance activities. See Table 5.

The boiler must not be installed in the same room as refrigeration containing equipment such as a chiller or heat pump unless a refrigerant detector is installed and interlocked with the boiler to shut down the burner in the event of refrigerant leakage. This requirement must be met for all installations including where combustion air is ducted from the outdoors.

⚠ WARNING

Do not terminate venting into an enclosed area.

Never use open flame or smoke from a cigarette, cigar, or pipe as a testing method during boiler installation, operation, or maintenance.

Foreign substances, such as combustible volatiles in the combustion system can create hazardous conditions. If foreign substances can enter the air stream, the boiler combustion air inlet must be piped to an outside location.

- Particulate matter (example: sheetrock, fiberglass, cement, plaster board, dirt, dust, lint) or chemicals (example: chlorine, sulfur, freon, fluorine, perchlorethylene, halogenated compounds) in the combustion air supply to the boiler will cause damage or failure to the heat exchanger and/or burner, and is not covered under warranty. High-risk situations for particulate matter to be in the air include construction and maintenance activities. See Table 5.

► *NOTE: Pool and laundry room air may be contaminated with chlorine or fluorine compounds. If allowed to enter the combustion air supply, these contaminants will significantly increase the acidity of flue gas condensate, potentially damaging heat transfer surfaces. Damage to the heat exchanger due to poor combustion air quality is not covered under warranty.*

- Ensure there is not negative pressure in the boiler room. The boiler room pressure must be neutral relative to the outdoors.

TABLE 5 - PRODUCTS/CONTAMINANTS TO AVOID

Products to avoid	Products containing chloro/flouorocarbons; chlorine-based products; calcium chloride products, sodium chloride products, paint and varnish removers, hydrochloric acid, muriatic acid, cements, glues, antistatic fabric softeners, Freon, drywall particles, dirt, fiberglass
Areas with the potential to have contaminants	Dry cleaning/laundry areas; swimming pools; repair shops; processing plants; manufacturing plants; active construction sites; chemical storage; food processing plants; farms, cooling towers, chillers

■ Combustion Air Supply From the Boiler Room

Adhere to the following for installation:

- Adequate combustion air and ventilation must be supplied to the boiler room in accordance with local codes and NFPA54/ANSI Z233.1, Section 9.3, Air for Combustion and Ventilation or CSA-B149.1 for Canada. The minium net free area requirements in Table 6 may not supersede local and jurisdictional codes and regulations where there codes and regulations require an openingQ of greater net free area. The boiler room must meet the NFPA criteria for a non-confined space. See Figure 23.
- Verify combustion air is taken from the outdoors and not from the inhabited or occupied spaces within the building. Ensure space and nearby products are evaluated for the potential of combustion air contaminants. See Table 5.
- For installations providing two permanent openings directly communicating with the outdoors, the minimum net free area of each opening is 1 in² per 4,000 BTU/hr of the total input capacity of the combined burners located in the boiler room. Ensure a high opening commences within 12 inches of the ceiling, and a low opening commences within 12 inches of the floor. See Table 6.
- For installations providing a single permanent opening directly communicating with the outdoors, the minimum net free area of the opening is 1 in² per 3,000 BTU/hr of the total input capacity of the combined burners located in the boiler room. See Table 6.

- For multiple boiler installations, multiply the number of boilers by required net free area per boiler.

TABLE 6 - MAKE-UP AIR VENTILATION OPENINGS

Boiler Input Capacity (MBTU/HR)	Two Openings Min. Net Free Area Each (SQFT)		Single Opening Only Min. Net Free Area (SQFT)
	Low	High	
750	1.3	1.3	1.7
1000	1.8	1.8	2.3
1500	2.6	2.6	3.5
2000	3.5	3.5	4.6

- The net free area required for the boiler(s) is in addition to the combustion or ventilation air supply requirements of other equipment sharing the same space such as water heaters, generators, air compressors, or other boilers. The boiler room must have an opening or openings not less than the total net free area required for all types of equipment.
- Consider the blocking effects of louvers, grills, and screens on the net free area of each opening. Ensure ventilation openings are unobstructed.
- Where mechanical combustion air supply systems are used, such as a combustion air supply fan or a motorized louver, they must be interlocked with the boiler control panel to prove operation prior to burner ignition and during burner operation. Where manual louvers are used, ensure they are fully open prior to operating the boiler(s).
- A 90° elbow is recommended on the air inlet to prevent debris falling into the cabinet.

■ Combustion Air Ducted from the Outdoors

The combustion air supply may be ducted to the air inlet of the boiler.

Adhere to the following for installation:

- An adapter (not supplied with boiler) may be required to connect the boiler air inlet to the combustion air ducting/piping.
- **NOTE:** The weight of combustion air intake piping must not be supported by the boiler. Ensure air intake piping is externally supported on hangers or straps.
- The boiler room must not contain contaminated air.
 - The combustion air intake termination must be located as to not be subjected to the intake/exhaust effects of other mechanical equipment such as other fuel-fired heating equipment, loading docks, generators, air handling systems, and cooling towers.
 - Ensure the boiler room air is maintained at a dew point temperature below the temperature of the combustion air. Failure to provide adequate ventilation or control dew point temperature may result in water or ice build-up on the combustion air piping, leading to increased maintenance or damage to boiler components.
 - Insulating the combustion air intake duct is not recommended.
 - The air intake system must be designed to prevent any moisture from draining to the boiler. Slope the air intake duct down away from the boiler. See Figure 24.

⚠ WARNING

All information in this manual is for reference and guidance purposes, and does not substitute for required professional training, conduct, and strict adherence to applicable jurisdictional/professional codes and regulations.

⚠ CAUTION

Ensure there is not a negative pressure in the boiler room. The boiler room pressure must be neutral relative to the outdoors.

Particulate matter or chemicals (example: chlorine, fluorine, perchlorethylene, halogenated compounds) in the combustion air supply to the boiler will cause damage or failure to the burner. High-risk situations for particulate matter to be in the air include construction and maintenance activities. See Table 5.

WARNING

All information in this manual is for reference and guidance purposes, and does not substitute for required professional training, conduct, and strict adherence to applicable jurisdictional/professional codes and regulations.

CAUTION

Do not use insulation on polypropylene materials. Use of insulation may elevate pipe wall temperatures, resulting in the potential for vent material failure.

NOTE

Listing precludes direct vent witness test.

7. Air Intake pipes and fittings shall be Schedule 40 PVC pipe or smooth-walled galvanized steel. All Schedule 40 PVC pipe, fittings, primer and cement must conform to American National Standard Institute and the American Society for Testing and Materials (ANSI/ASTM standards) per pipe manufacturer's requirements.
8. Intake PVC piping must be assembled using cement. This will ensure that the intake is air tight and will not allow contaminants from the boiler room into the boiler. The cement must be free flowing and contain no lumps, undissolved particles or any foreign matter that adversely affects the joint strength or chemical resistance of the cement. The cement must not show gelation, stratification, or separation that cannot be removed by stirring.
9. Adhere to procedure for cementing joints (per ASTM D2855).
10. Avoid sidewall exhaust with roof terminated intake air. This may lead to reverse stack effect when the boiler is idle.

Combustion Air Filter

The air filter requires monthly maintenance and, at minimum, annual replacement. See **Maintenance** section of this manual.

Flue Gas Exhaust Venting

This boiler is equipped with a vent connection at the lower rear of the boiler.

Adhere to National Fuel Gas Code (ANSI Z223.1) and the following for installation:

1. This boiler is a Category II/IV appliance, thus requiring special gas vent material appropriate for condensing, positive pressure applications. Any venting material supplied for the Endura boiler must be AL29-4C or 316L/444 SS, listed and labeled to UL 1738, and guaranteed appropriate for the application by the manufacturer and supplier of the venting. It is also acceptable to vent as Category II condensing, negative pressure, for which an upsized diameter is typically required.
2. Where allowed by the authority having jurisdiction (AHJ), the exhaust may be vented using Schedule 40 PVC, Schedule 40 CPVC, or Polypropylene listed and labeled to UL 1738 or ULC S636. If venting with Schedule 40 PVC, at minimum the first 8 inches of pipe must be Schedule 40 CPVC, see Figure 19 and Table 8. Do not insulate plastic exhaust vents. Canada only: Schedule 40 PVC, CPVC, or Polypropylene vent materials must be listed and labeled to ULC S636.
3. Do not use boot tees or bullhead tees. Use inline condensate drains in place of boot tees at the bottom of a vertical rise.
4. Barometric dampers are physically open to the mechanical space. When used in a condensing boiler application with negative pressure (Category II) exhaust vent, the design must prevent flue gas condensate from draining down the outside of the stack or dripping into the space. For installation using a barometric damper, verify the air openings meet the

requirements in Table 6, and a spill switch and a Carbon Monoxide detector are installed and interlocked with the boiler(s). Barometric dampers must never be used in a positive pressure (Category IV) exhaust or ducted combustion air application.

5. Refer to Table 7 for acceptable vent materials and temperature limits. The use of cellular core PVC/CPVC or Radel® (polyphenylsulfone) in venting systems is prohibited.
6. A stainless steel adapter (not supplied) specific to vent manufacturer type and material will be required. See Table 8 and Figure 19. Consult the venting supplier for guidance.
7. Adequate provision must be made to support the weight of the exhaust venting. It must not be supported by the boiler exhaust connection.
8. Following the venting manufacturer’s instructions for installation of flue gas venting.
9. Horizontal runs must allow for flue gas condensate to drain back with a minimum upward pitch of ¼” (7 mm) per foot (300 mm) run. Failure to do so can create a condensate pocket, which can result in an inoperative boiler. There must be no low spots in the exhaust vent, as this can also result in a condensate pocket.
10. The boiler control will automatically disable and reset the burner should the flue gas temperature exceed the stack material type setting. This may be field adjusted (See Operation) for installations utilizing a material in Table 7 approved for higher flue gas temperatures. To prevent the likelihood of alarms caused by approaching venting material limitations, it is suggested to use AL 29-4C, 316L, or Polypropylene in applications where return water temperatures can exceed 140°F .
11. If stack drains are installed, they must be pitched back to the condensate drain trap, minimum pitch of ¼” (7 mm) per foot (300 mm) run.

TABLE 7 - ACCEPTABLE EXHAUST VENTING MATERIALS

Venting Material	AL-294C (UL1738)	316L SS (UL1738)	Polypropylene (UL 1738)	Sch. 40 CPVC	Sch. 40 PVC
Maximum Flue Gas Temperature	600° F (315° C)	550° F (287° C)	230° F (110° C)	200° F (93° C)	158° F (70° C)



WARNING

Fulton accepts no liability for installation of any venting, including the selection of venting materials. Maximum allowable flue gas operating temperatures may vary by manufacturer. Consult the venting supplier for maximum allowable temperatures.

WARNING

Fulton accepts no liability for installation of any venting, including the selection of venting materials. Maximum allowable flue gas operating temperatures may vary by manufacturer. Consult the venting supplier for maximum allowable temperatures.

TABLE 8 - FULTON PART NUMBERS FOR FLUE GAS EXHAUST ADAPTERS

Manufacturer	Line	Stack Material	Part/Catalog Number	
			EDR-750-1500	EDR-2000
M&G DuraVent®	FasNSeal®	AL29-4C	810010020	810010021
M&G Security	SecureStack® Pro	304/316 SS	SSD6FEDRUK	SSD8FEDRUK
Schebler	eVent™	AL29-4C	EVD-AKFE-06R	EVD-AKFE-08R
Selkirk® HeatFab®	Saf-T Vent®	AL29-4C	CCA06EDR	CCA08EDR
Jeremias®	GOV	444 SS	DWKL-FBA-EDR6	DWKL-FBA-EDR8
Metal-Fab, Inc.	CORR/GUARD®	AL29-4C	6FCSSBAI	8FCSSBAI
NovaFlex Z-Flex®	Z-Vent®	AL29-4C	2SVSAEDR6	2SVSAEDR8
NovaFlex Z-Flex®	Z-Dens®	Polypropylene	2ZDAEDR6	2ZDAEDR8
Centrotherm	InnoFlue®	Polypropylene	ISSA0606 & ISVIB06	ISSA0808 & ISVIB08
M&G DuraVent®	PolyPro®	Polypropylene	810010023	810010025
M&G DuraVent®	OEM for Endura	CPVC / PVC	Fulton 4-50-071005	Fulton 4-50-072005

Note: This table lists factory approved flue gas venting adapters; other manufacturers may be used provided they meet the special gas vent requirements of this boiler.

Common Flue Gas Venting Layouts

It is possible to combine the air intake and/or exhaust venting of multiple Endura boilers. The pressure drop across the entire common system, the combined total of both air intake and exhaust, must comply with the draft pressure requirements for an individual boiler, see Table 4.

Refer to Figure 20 and adhere to the following for installation:

1. Consult your venting supplier for guidance in designing common vented installations. The system must be thoroughly evaluated by a professional using accepted engineering practices to prevent backflow of exhaust gases through idle boilers.
2. This boiler is not approved for common venting with other equipment, such as steam boilers, water heaters, generators, and other types of equipment.
3. The AHJ may require the installation of a CO detector interlocked with the boiler(s), this is recommended best practice even where not required.
4. A constant diameter common header is recommended. Do not use the static regain method.
5. A minimum 1/4" rise per foot run is required for horizontal sections.
6. Where individual stacks transition into the common header, a 45 degree reducing tee or elbow in the direction of flow is recommended. Straight-in or 90 degree tees must not be used.
7. Precautions must be taken to ensure that the draft pressure at each boiler is maintained within in the required range (refer to Table 4) throughout all conditions while also maintaining a slight negative draft pressure in the

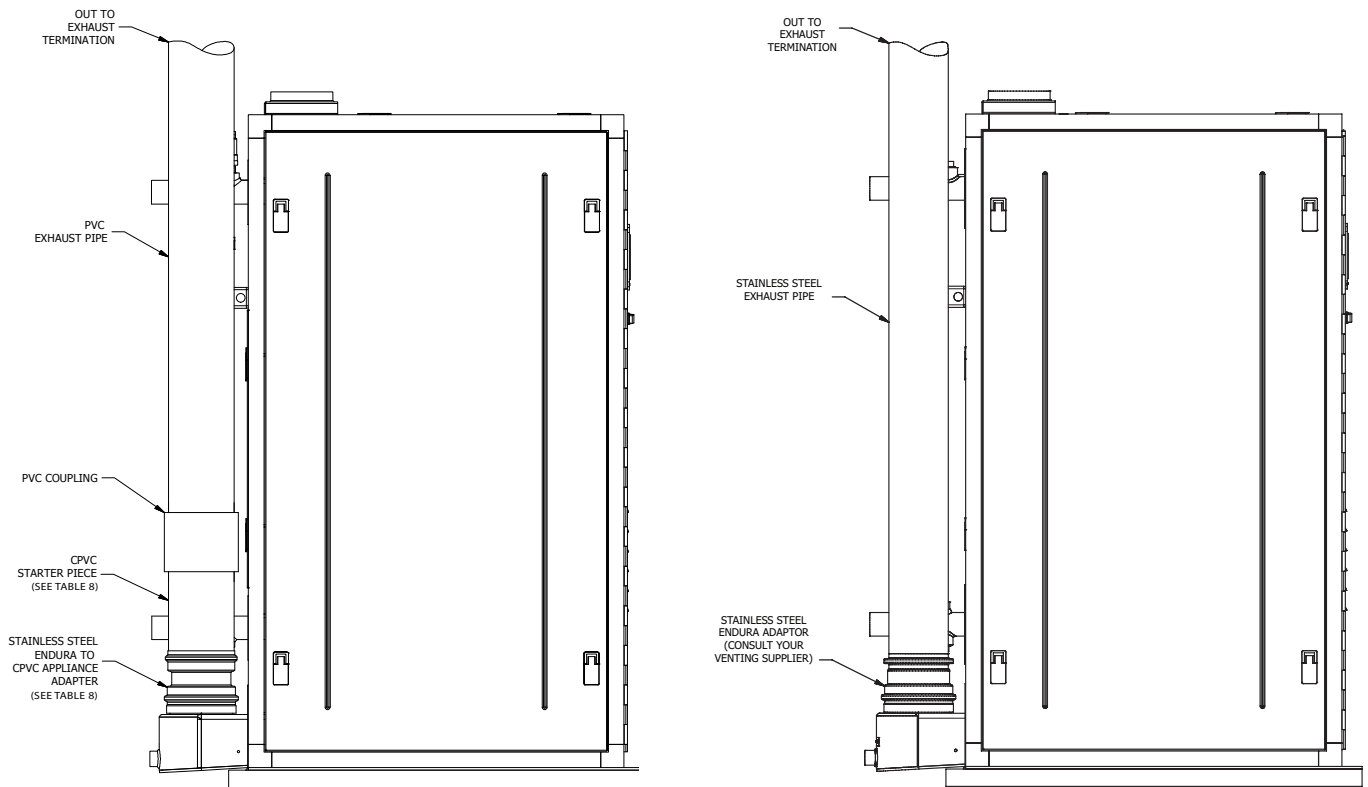
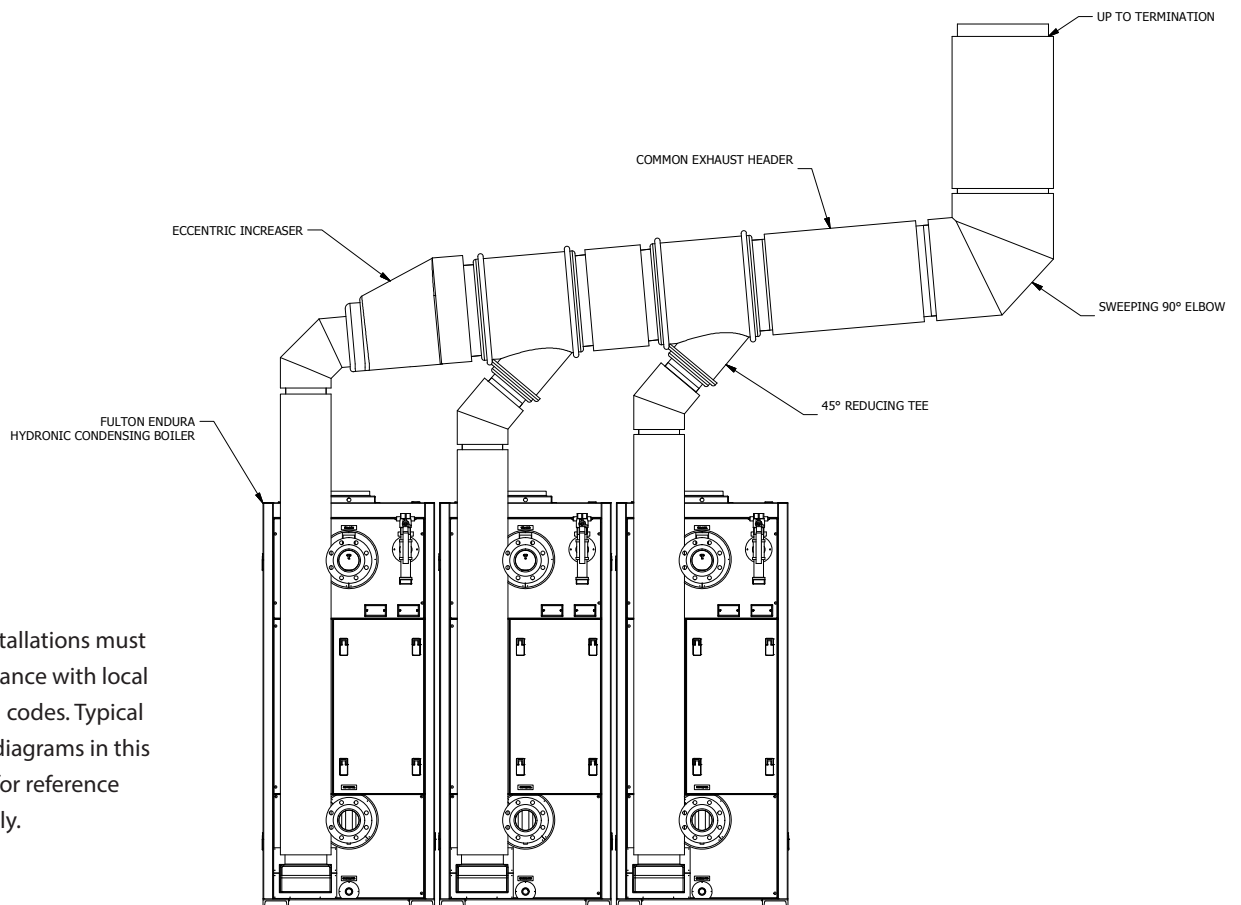

FIGURE 19 - ENDURA EXHAUST VENTING



Note: All installations must be in compliance with local and national codes. Typical installation diagrams in this manual are for reference purposes only.

FIGURE 20 - ENDURA COMMON EXHAUST VENTING; TYPICAL INSTALLATION GUIDELINES

WARNING

All information in this manual is for reference and guidance purposes, and does not substitute for required professional training, conduct, and strict adherence to applicable jurisdictional/professional codes and regulations.

CAUTION

Ensure there is not a negative pressure in the boiler room. The boiler room pressure must be neutral relative to the outdoors.

Particulate matter or chemicals (example: chlorine, fluorine, perchlorethylene, halogenated compounds) in the combustion air supply to the boiler will cause damage or failure to the burner. High-risk situations for particulate matter to be in the air include construction and maintenance activities. See Table 5.

common exhaust header. Consider all possible operating conditions of the exhaust system specific to the application, including:

- Low and high flue gas temperatures
- Low and high ambient air temperatures
- All boilers operating at their maximum input rating capacity
- One boiler in the system operating at the low fire position
- No boilers on, pre-purge and ignition

8. Consider the natural draft effects associated with vertical exhaust vent rise. Over-draft control accessories, such as modulating stainless steel dampers, may be required to mitigate a negative pressure exceeding the value in Table 4. An undersized common exhaust vent or pressure drop due to the horizontal run can create a positive pressure common exhaust situation which may require a mechanical draft assist (exhaust fan) system.

When designing a draft system for a quantity of two or more boilers, the following items must be considered and addressed by the parties responsible for designing and providing that system:

■ Common Venting Exhaust Backflow Prevention

1. When combining the exhaust vents of multiple Endura boilers, the system must be designed to guarantee flue gas and exhaust will not backflow through an idle boiler. This requires appropriately sizing a Category II common exhaust vent to maintain a slight negative draft pressure of -0.01 to -0.04"wc throughout all operating conditions when one or more boilers are idle.
2. It is recommended to install individually piped intake vents or use neutral pressure boiler room air with a common exhaust system. For common exhaust vent applications also combining combustion air intake (CAI) ducts into a common duct, it is necessary to upsize the common CAI duct for a negligible pressure loss.
3. If the common exhaust configuration does not allow for a stable negative pressure under all operating conditions then a mechanical draft assist system, such as a variable speed exhaust fan, may be required.

Venting Terminations

Adhere to National Fuel Gas Code (ANSI Z223.1) and the following for installation:

1. Do not terminate the venting in an enclosed area. Care must be taken when selecting the type and orientation of the terminations.
2. All vent pipes and fittings must be installed with appropriate air space clearances to combustibles. These air space clearances apply to indoor or outdoor vents—whether they are open, enclosed, horizontal or vertical or pass through floors, walls, roofs, or framed spaces (See Figures 22, 23 and 24). The air space clearances should be observed to joists, studs, sub floors, plywood, drywall or plaster enclosures, insulating sheathing, rafters, roofing, and any other material classed as combustible.

- To prevent the possible re-circulation of flue gases, the vent designer must take into consideration such things as prevailing winds, eddy zones, building configurations, etc. Adverse conditions effect operation reliability and durability of the boiler(s).
- The required minimum air space clearances also apply to electrical wires and any kind of building insulation.
- Listed termination parts must be used.
- Select the air intake point of penetration where a minimum of 1/4" per foot (6.35 mm per .3 m) upward pitch can be maintained.
- It is recommended to install a mesh bird screen, with minimum 1/2" by 1/2" openings, at the combustion air intake termination. Climates subject to extreme cold may require alternate configurations to provide an increased surface area, such a cylindrical basket screens. Consult your venting supplier for recommendations.
- It is important to locate the exhaust termination in such a way that it does not become blocked due to snow, ice, and other natural or man-made obstructions. If terminating into a prevailing wind, direct elbow upward. Avoid areas (example: courtyards) where swirling high winds may be present.

■ Wall Thimble Installation

Adhere to the following for installation (see Figure 21):

- Insert the thimble through the wall from the outside.
- Secure the outside flange to the wall with nails or screws, and seal with adhesive material.

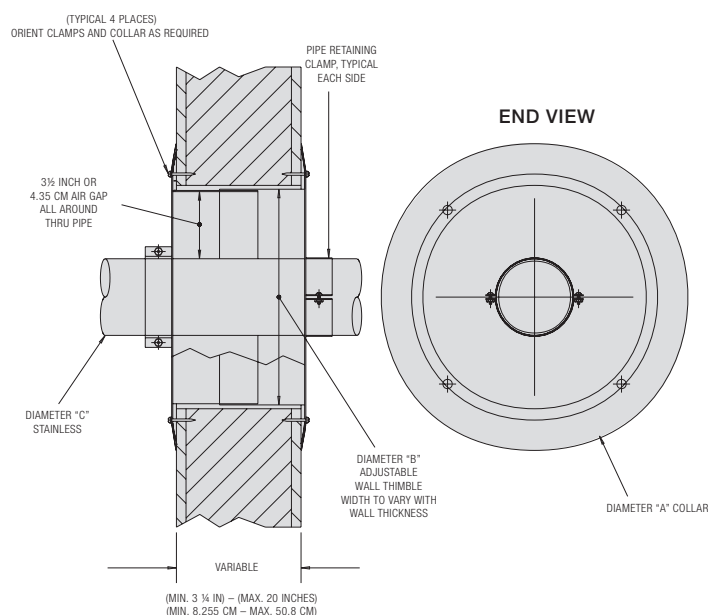

FIGURE 21- WALL THIMBLE INSTALLATION

- Install the inside flange to the inside wall, secure with nails or screws, and seal with adhesive material.
- Pass the vent pipe through the thimble from the outside and join to the rest of the vent system. Seal the pipe to the thimble flange with adhesive material.
- Install two pipe retaining clamps around the intake as well as vent pipes on both ends of the wall thimble (on the inside and outside of the wall) through which intake and vent pipes are passed. They will prevent the intake and vent pipes from being pushed or pulled.

■ Roof Vent Termination

Adhere to the following for installation (see Figure 22 and 23):

- The minimum vent height should extend at least 3 feet (0.9 m) above the roof, or at least 2 feet (0.6 m) above the highest part of any structure within 10 feet of the vent.
- When installing inlet and exhaust terminations above the roof, the exhaust outlet must be installed 4 feet (1.22 m) minimum above and 4 feet (1.22 m) minimum downwind from air supply inlet to prevent exhaust recirculation. Greater separation is strongly recommended.
- The use of rain caps on the flue gas exhaust termination is not recommended. Rain caps contribute to ice buildup, stagnant vapor plumes, flue gas recirculation (FGR) and excess vent restriction. See Figure 22 and 23.

■ Side Wall Vent Termination

Adhere to the following for installation (see Figure 24):

► **NOTE:** The vent termination is joined to the vent pipe outside the wall. Use the same joining procedures for vent pipe and fittings.

- When penetrating a non-combustible wall, the hole through the wall must be large enough to maintain the pitch of the vent and provide sealing. Use adhesive material to seal around the vent on both sides of the wall. When penetrating a combustible wall, a wall thimble must be used.
- High-wind areas may require special termination consideration. See Figure 24.
- The termination of the vent system must be at least 12 inches (30.48 cm) above the finished grade, or at least 12 inches (30.48 cm) above normal snow accumulation level (for applicable geographical areas).

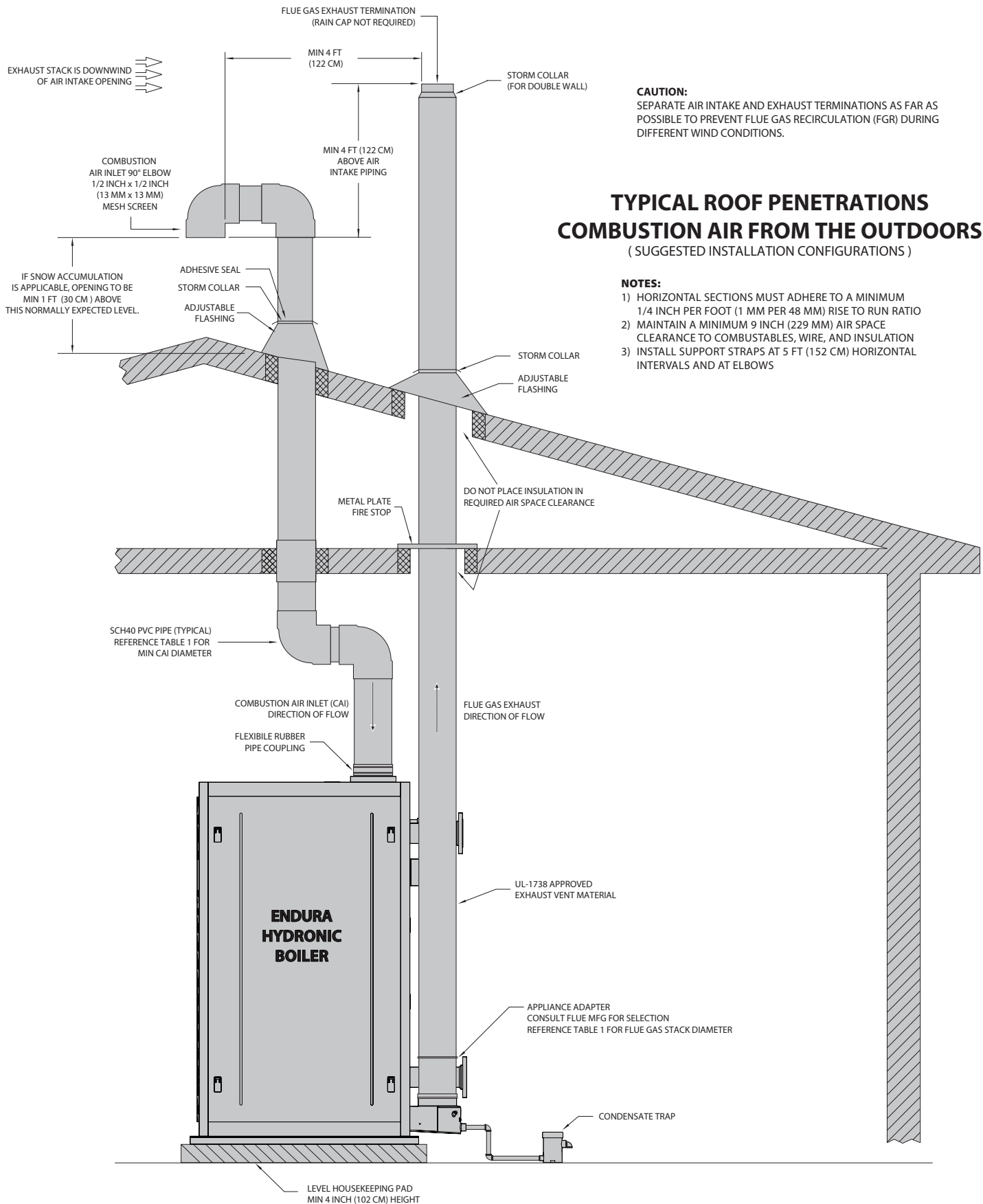
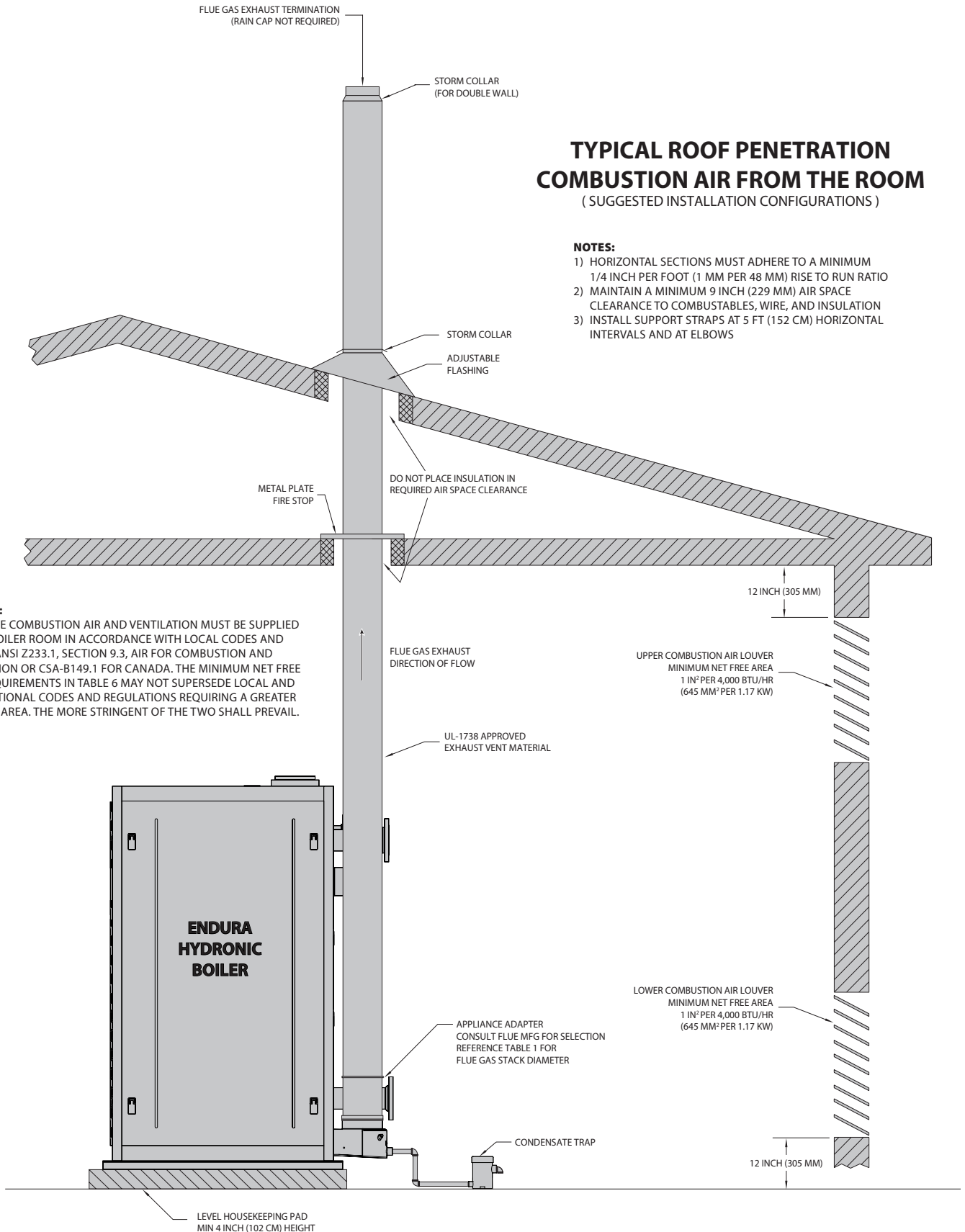

FIGURE 22 - ROOF PENETRATION DETAILS



TYPICAL ROOF PENETRATION
COMBUSTION AIR FROM THE ROOM
(SUGGESTED INSTALLATION CONFIGURATIONS)

- NOTES:**
- 1) HORIZONTAL SECTIONS MUST ADHERE TO A MINIMUM 1/4 INCH PER FOOT (1 MM PER 48 MM) RISE TO RUN RATIO
 - 2) MAINTAIN A MINIMUM 9 INCH (229 MM) AIR SPACE CLEARANCE TO COMBUSTIBLES, WIRE, AND INSULATION
 - 3) INSTALL SUPPORT STRAPS AT 5 FT (152 CM) HORIZONTAL INTERVALS AND AT ELBOWS

CAUTION:
ADEQUATE COMBUSTION AIR AND VENTILATION MUST BE SUPPLIED TO THE BOILER ROOM IN ACCORDANCE WITH LOCAL CODES AND NFPA54/ANSI Z233.1, SECTION 9.3, AIR FOR COMBUSTION AND VENTILATION OR CSA-B149.1 FOR CANADA. THE MINIMUM NET FREE AREA REQUIREMENTS IN TABLE 6 MAY NOT SUPERSEDE LOCAL AND JURISDICTIONAL CODES AND REGULATIONS REQUIRING A GREATER NET FREE AREA. THE MORE STRINGENT OF THE TWO SHALL PREVAIL.

FIGURE 23 - ROOF PENETRATION WITH COMBUSTION AIR LOUVERS DETAILS

TYPICAL SIDE WALL PENETRATIONS (SUGGESTED INSTALLATION CONFIGURATIONS)

NOTES:

- 1) HORIZONTAL SECTIONS MUST ADHERE TO A MINIMUM 1/4 INCH PER FOOT (1 MM PER 48 MM) RISE TO RUN RATIO
- 2) MAINTAIN A MINIMUM 9 INCH (229 MM) AIR SPACE CLEARANCE TO COMBUSTIBLES, WIRE, AND INSULATION
- 3) INSTALL SUPPORT STRAPS AT 5 FT (152 CM) HORIZONTAL INTERVALS AND AT ELBOWS

CAUTION:

SEPARATE AIR INTAKE AND EXHAUST TERMINATIONS AS FAR AS POSSIBLE TO PREVENT FLUE GAS RECIRCULATION (FGR) DURING DIFFERENT WIND CONDITIONS.

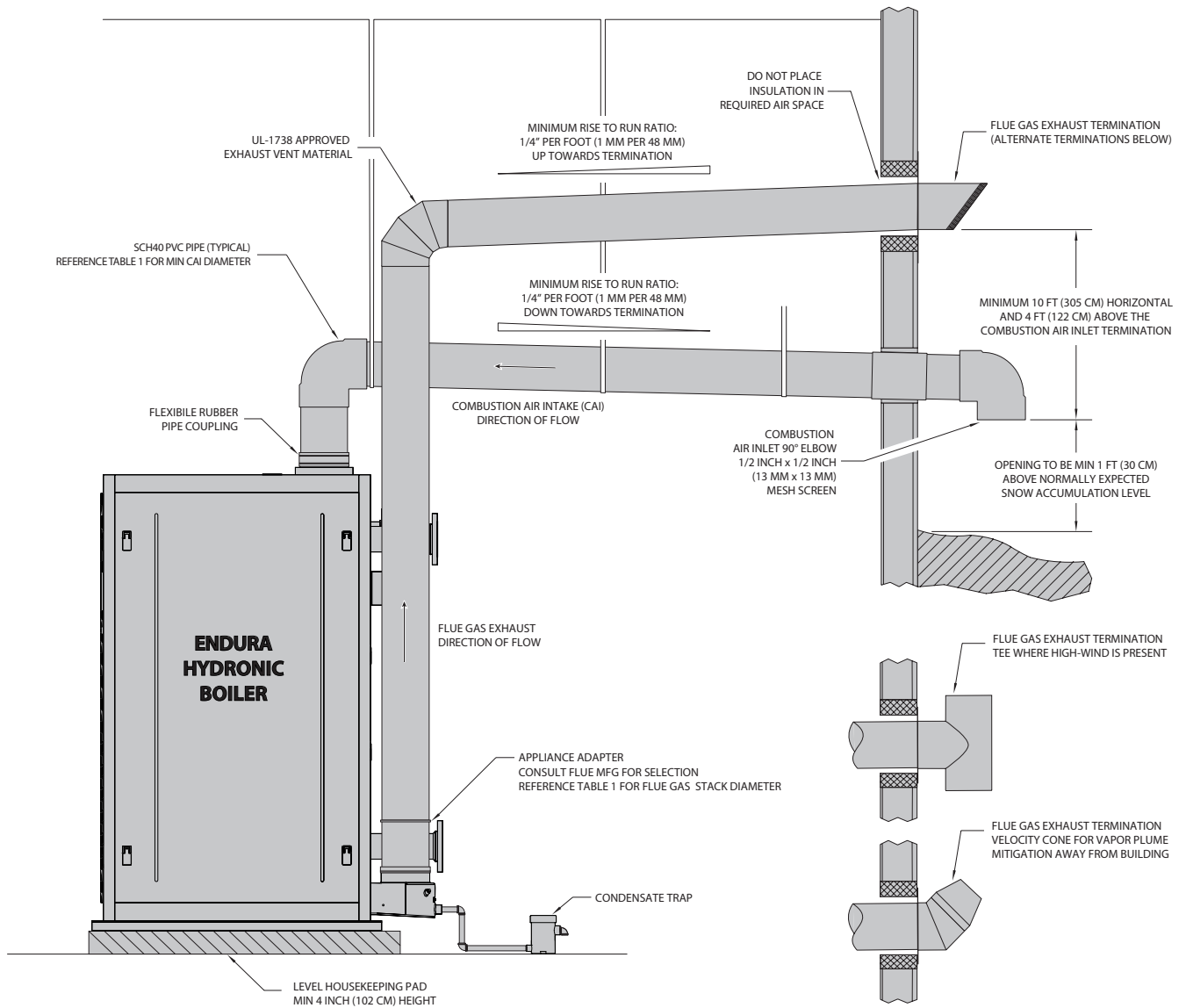
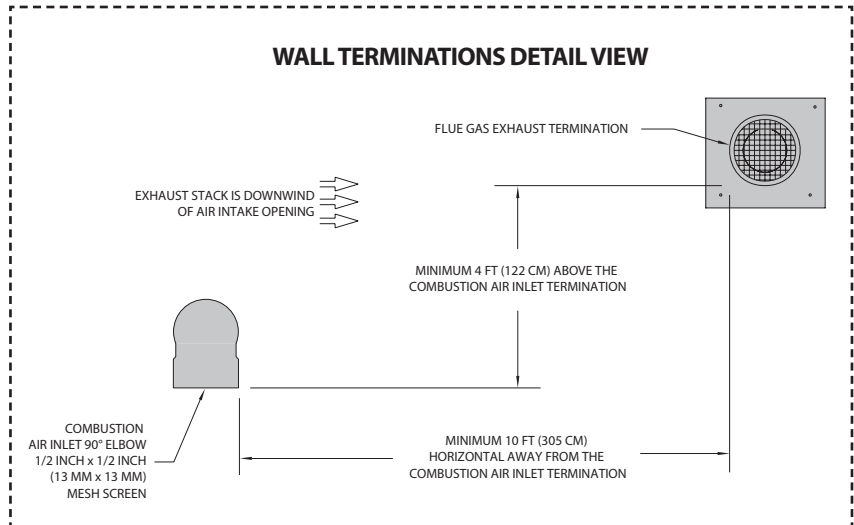

FIGURE 24 - SIDEWALL PENETRATIONS DETAIL

4. The termination of the vent system shall not be located over traffic areas such as public walkways, or over an area where condensate or vapor could create a nuisance or hazard.
 5. Do not terminate below operable windows and building openings unless exception is granted by the authority having jurisdiction.
 6. The vent terminations must be at least 4 ft (1.22 m) horizontally from electric meters, gas meters, regulators, and relief equipment.
 7. When installing inlet and exhaust terminations on the same wall, the exhaust outlet must be installed 4 feet (1.22 m) minimum above and 10 feet (3.05 m) minimum downwind from air supply inlet to prevent flue gas recirculation. Greater separation is strongly recommended.
 8. Under certain wind conditions, some building materials may be affected by flue products expelled in close proximity to unprotected surfaces. Sealing or shielding of the exposed surfaces with a corrosion resistant material (such as an aluminum sheet) may be required to prevent staining or deterioration. Flue should be directed away from surfaces, if possible.
- exhausts, so they will operate at maximum speed. Do not operate a summer exhaust fan. Close fireplace dampers.
4. Place the appliance being inspected in operation. Follow the lighting instructions. Adjust the thermostat so that the appliance will operate continuously.
 5. Test for spillage at the draft hood relief opening after 5 minutes of main burner operation. Do not use the flame of a match or candle or smoke from a cigarette, cigar or pipe.
 6. After it has been determined that each appliance remaining connected to the common venting system properly vents when tested as outlined above, return doors, windows, exhaust fans, fireplace dampers and any other gas-burning appliance to their previous conditions of use.
 7. Any improper operation of the common venting system should be corrected so the installation conforms with the National Fuel Gas Code, ANSI Z223.1. When resizing any portion of the common venting system, the common vent system should be resized to approach the minimum size as determined using the appropriate tables.

Removing an Existing Boiler

When an existing boiler is removed from a common venting system, the common venting system is likely to be too large for proper venting of the appliances remaining connected to it.

At the time of removal of an existing boiler, while the other appliances remaining connected to the common venting system are not in operation, the following steps should be followed with each appliance remaining connected to the common venting system placed in operation:

1. Seal any unused openings in the common venting system.
2. Visually inspect the venting system for proper size and horizontal pitch and determine that there is no blockage or restriction, leakage, corrosion or other deficiency, which could cause an unsafe condition.
3. Insofar as is practical, close all building doors and windows and all doors between the space in which the appliances remaining connected to the common venting system are located and other spaces of the building. Turn on clothes dryers and any appliances not connected to the common venting system. Turn on any exhaust fans, such as range hoods and bathroom

Assembly of Fulton Multi-Skid Systems

Adhere to the following for multi-skid engineered systems:

1. Refer to the Fulton mechanical/electrical drawings during assembly.
2. Ensure that equipment orientation allows for operation interface and maintenance.
3. Align the skids as shown on the drawings ensuring that skid fasteners (skid joint angles) are matched. The skid joint angles are a matched set and the edges of the fasteners should be exactly aligned.

► *NOTE: Do not bolt the skids to the housekeeping pad/floor until all of the piping has been reassembled and tightened.*

4. Ensure the skids are level and flat before fastening the skids together with the supplied bolts. The skids should be leveled front to back, side to side and corner to corner. Failure to properly level the skids will result in piping misalignment. A level or laser level should be used to verify skid alignment (when a standard

WARNING

All information in this manual is for reference and guidance purposes, and does not substitute for required professional training, conduct, and strict adherence to applicable jurisdictional/professional codes and regulations.

level is used, the length should be appropriate for the skid). If assembling multi-component support stands, attach sections using the supplied bolts through the tank frame mounting plates. These should be hand tight until all of the piping is assembled.

► *NOTE: Note: skids are leveled at the factory using a laser level.*

5. Connect the piping between the skids by matching the union connections and/or flange stamps and tightening. Refer to the mechanical drawing as necessary to confirm location of spool pieces etc. as the flange stamps are shown on the drawing in hexagonal callouts. The flange stamps should be matched and aligned (the flange stamps should be directly across from one another. Rotating a flange will result in piping misalignment). Bolts should be hand tight until all of the piping is assembled. Refer to the appropriate instructions to tighten the flanges to the required torque specifications. Support pipe runs as required.
6. Ensure that a low point drain is installed in the piping.
7. Connect the conduit runs between the skids and tighten conduit connectors.
8. Locate the supplied wiring for the equipment and pull wiring through the appropriate conduit runs. Electrical wires are labeled for easy landing. Connect all wiring per the Fulton supplied electrical drawings.
9. If a header is supplied, mount the header as shown in the mechanical drawing.

► *NOTE: For piping supplied in sections, make up and connect hand tight until all sections are in place to ensure sections align properly. Sections are match marked for reassembly.*

10. Tighten all connections, including threaded and flanged factory connections which may loosen during shipment.
11. Pneumatically test the piping (at 15 psig [103 kPa] maximum) prior to filling the systems.
12. Check bolts and connections for tightness after the first heat up cycle. Retorquing may be required.

Electrical Connections and Devices

The boiler is designed to operate within the following limits at the connection terminals:

- AC power supplied is within +/- 5% of the boiler rated voltage with the rated frequency applied; or AC power supplied is within +/- 5% of the rated frequency and with the rated voltage; or a combined variation in voltage and frequency of +/-5% (sum of absolute values) of rated values.

Full Load Amps (FLA) is the measured amperage for the boiler at its maximum operating condition at rated voltage. The type of breaker/fusing selected, in combination with the FLA, will affect proper circuit sizing/protection. Please refer to your state's adoption of NEC or the authority having jurisdiction for proper sizing/selection.

A connection box is provided on the back of the unit for high voltage wiring. A separate connection box is provided for low voltage and communication wiring. Do not run Building Management System (BMS) or any other communication wiring into the high voltage box.

The Endura cabinet has removable panels to facilitate access. Do not run conduit through or over access panels.

Adhere to the following when making electrical connections:

1. Install wiring in accordance with NEC Sec. 110.3(B) or CSA C22.1 for Canada for a maximum recommended branch circuit voltage drop of 3% and a maximum total voltage drop for a combination of both branch circuit and feeder not to exceed 5%.
2. Install wiring and ground in boiler in accordance with authority having jurisdiction or in absence of such requirements National Electrical Code, ANSI/NFPA 70.
3. Connect power to the boiler using connectors rated for the minimum in Table 1, and are compliant with local electrical codes.
4. Provide separate power supplies for external devices. Do not power external devices (example: isolation valves, draft systems) through the boiler.



WARNING

All information in this manual is for reference and guidance purposes, and does not substitute for required professional training, conduct, and strict adherence to applicable jurisdictional/professional codes and regulations.



CAUTION

Operating outside electrical requirements may de-rate the boiler and/or damage electrical components. There is no warranty on components that fail due to improper electrical service.

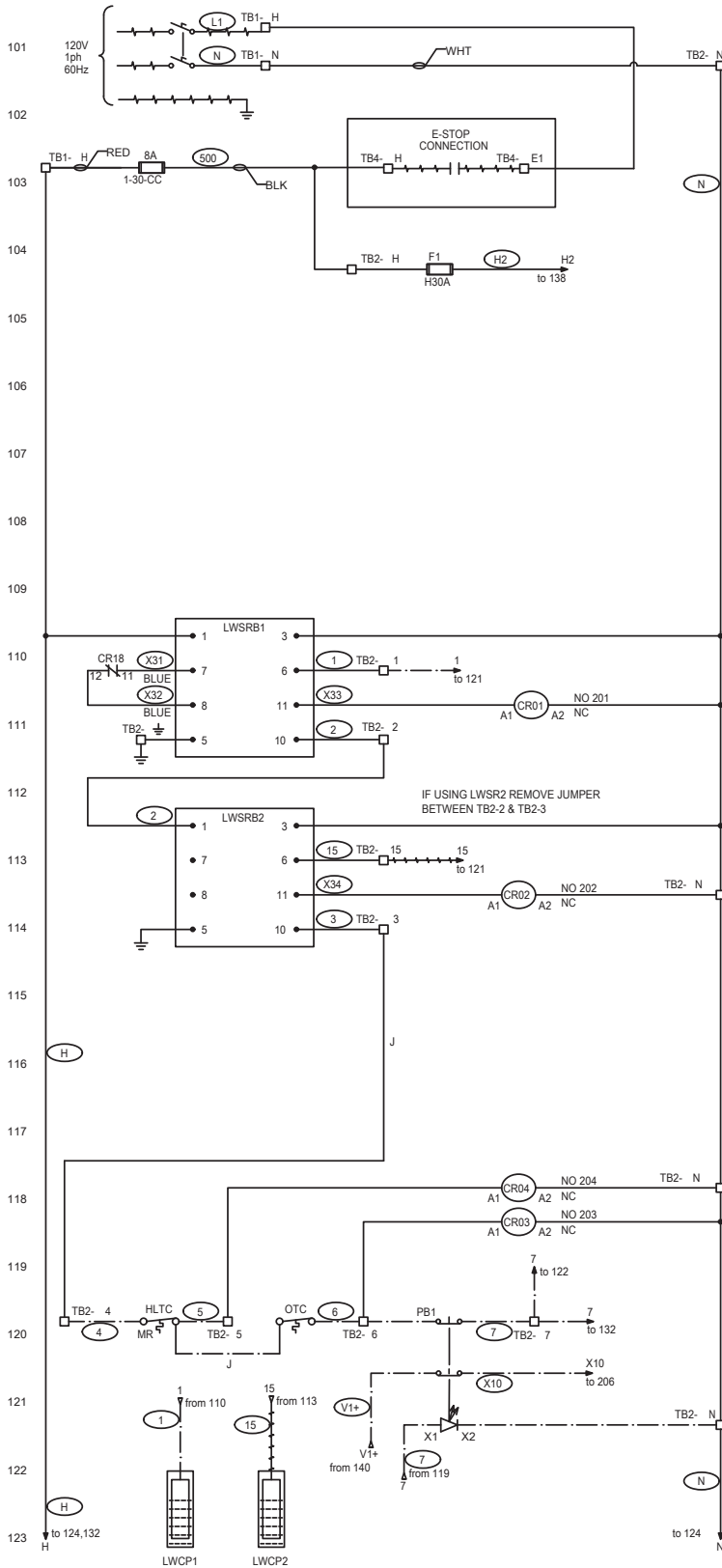

REFERENCE DESIGNATION

ITEM	DESCRIPTION	TAGS	QTY
1	PROOF OF CLOSURE	POC	1
2	LOW WATER CUTOFF PROBE	LWCP1 LWCP2	2
3	FLAME ROD	FR	1
4	MAIN GAS VALVE	MV1	1
5	COMBUSTION AIR SWITCH	AS	1
6	BLOWER MOTOR	BM	1
7	OPERATING TEMPERATURE CONTROL	OTC	1
8	HIGH LIMIT TEMP CONTROL	HLTC	1
9	WATER LEVEL SAFETY RELAY 120VAC	LWSR1	1
10	11 PIN RELAY BASE	LWSRB1 LWSRB2	2
11	SIEMENS PLUG CONNECTOR SET	FPPS	1
12	FLAME PROGRAMMER LMV36 120VAC	FP	1
13	15.6KVA TRANSFORMERS	IT1	1
14	HIGH GAS PRESSURE SWITCH	HGP	1
15	LOW GAS PRESSURE SWITCH	LGP	1
16	FUEL SERVO MOTOR	SM2	1
17	1 POLE 30 AMP FUSE HOLDER CLASS CC	1-30-CC	1
18	30 AMP CUBEFUSE HOLDER TCFH30N	H30A	1
19	CUBE FUSE	F1	1
21	RS232-RS485 MODULE CVM(OCI)	CVM(OC1)	1
22	1 POLE SIGNAL RELAY 120VAC	CR01 CR02 CR03 CR04	4
23	COLOR SCREEN	HMIPLC	1
24	MODULE 2	MODULE 2	1
25	MODULE 3	MODULE 3	1
26	MODULE 4	MODULE 4	1
27	PLC CPU MODULE	MODULE CPU	1
28	N.O. LIGHTED PUSH BUTTON	PB1	1
29	CONTACT BLOCK	CB	1
30	24VDC SLIM LINE 1 POLE CONTROL RELAY	CR06 CR08 CR09 CR10 CR11 CR12 CR13 CR14 CR16 CR18 CR19	11
31	LED LIGHT 120VAC	LED	1
32	MODULE 1	MODULE 1	1
33	ETHERNET HUB	EH	1
34	GROUND BLOCK UT4 PE PHOENIX	SHLD	1
35	CONTROL RELAY 24VDC	CR07 CR15	2
20	POWER SUPPLY 120VAC - 24VDC	PS	1
36	STAINLESS STEEL PT100 SENSOR	RTD1 RTD3	2
37	BRASS PT100 SENSOR	RTD2 RTD4	2

EDR 750 - 2000 PURE CONTROL REFERENCE ONLY ELECTRICAL SCHEMATIC DIAGRAM

NOTE: ALWAYS REFER TO THE SCHEMATIC INSIDE YOUR BOILER FOR THE PRINT SPECIFIC TO YOUR BOILER

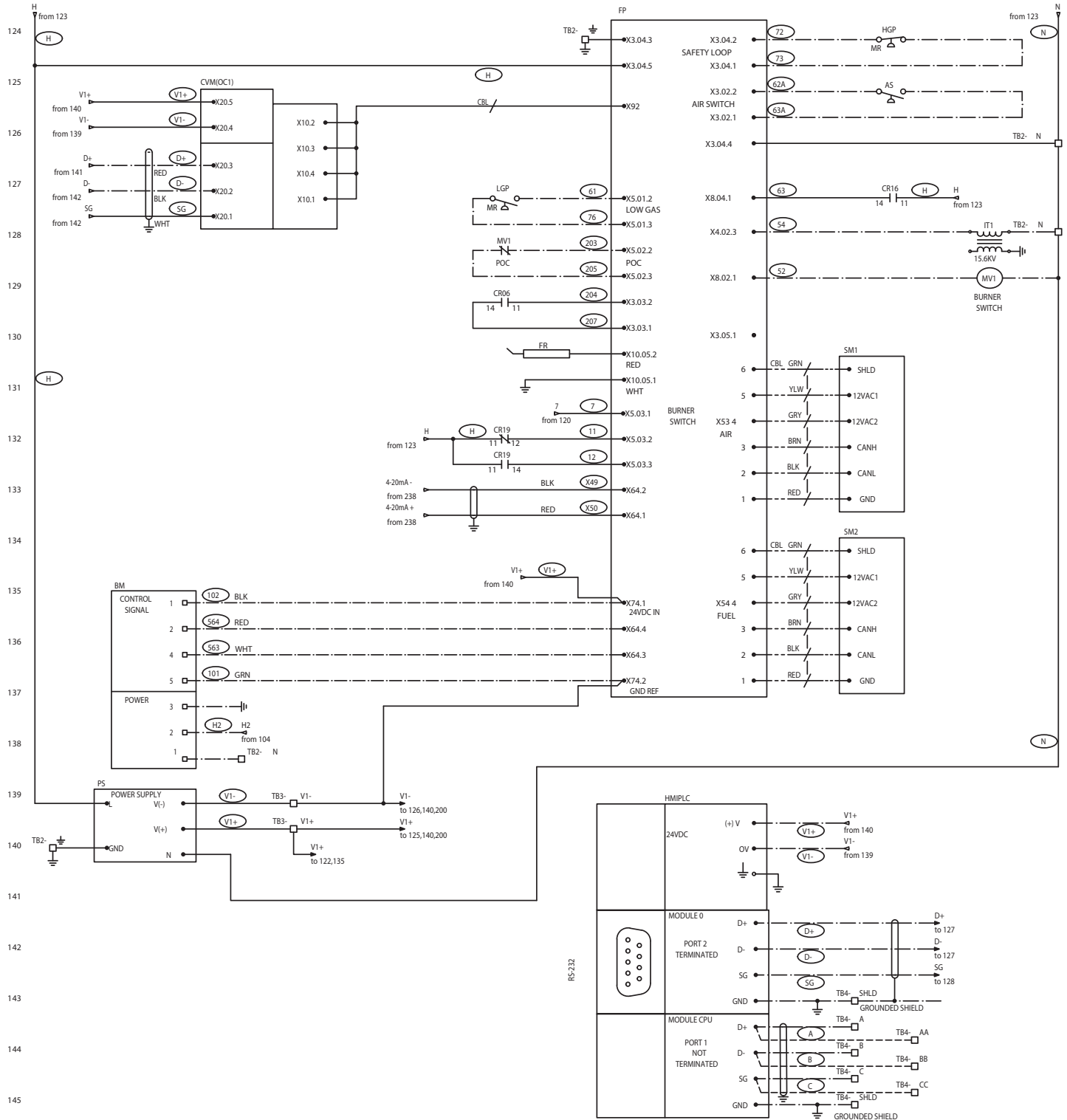

EDR 750 - 2000 PURE CONTROL REFERENCE ONLY ELECTRICAL SCHEMATIC DIAGRAM (CONTINUED)

NOTE: ALWAYS REFER TO THE SCHEMATIC INSIDE YOUR BOILER FOR THE PRINT SPECIFIC TO YOUR BOILER

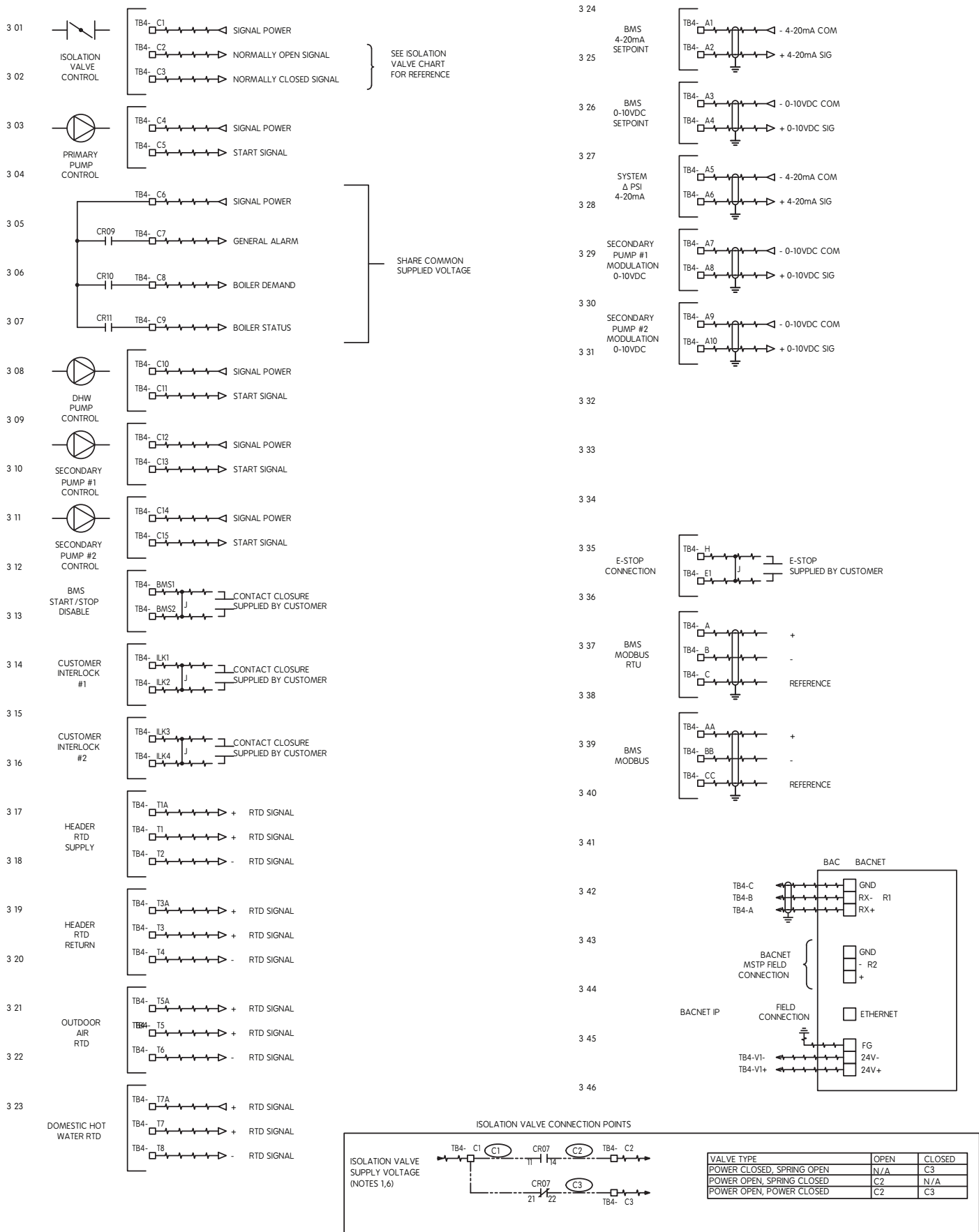

EDR 750-2000 PURE CONTROL REFERENCE ONLY FIELD CONNECTIONS

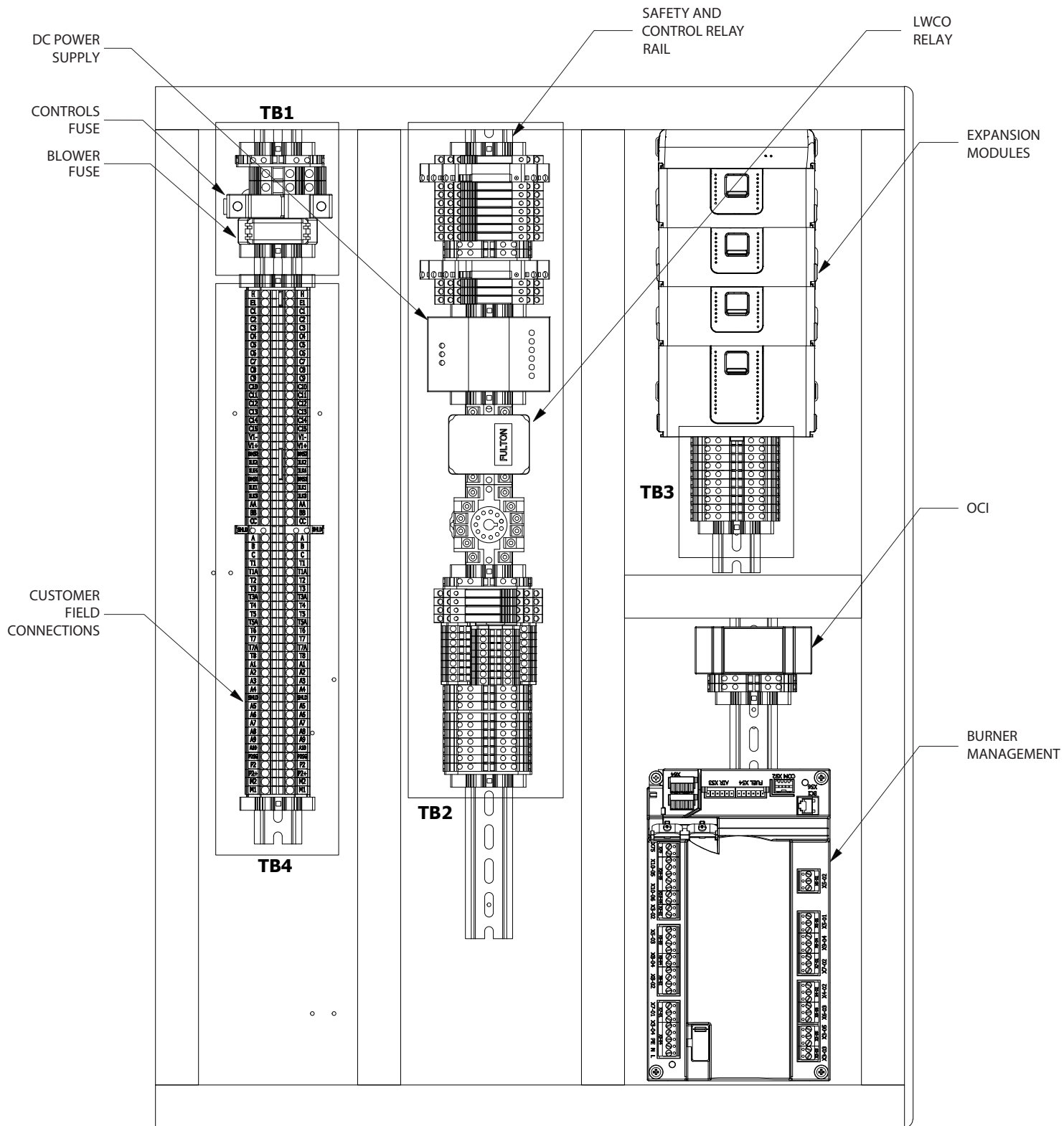

FIGURE 25 - ELECTRICAL CONTROLS LAYOUT
(REFERENCE ONLY, LAYOUT MAY VARY)

■ Junction Box Locations for Field Wiring

Factory mounted junction boxes (Figure 26) are provided at the rear of the boiler for routing field wiring to the boiler control panel. Do not run wiring directly through the removable or hinged panels doors.

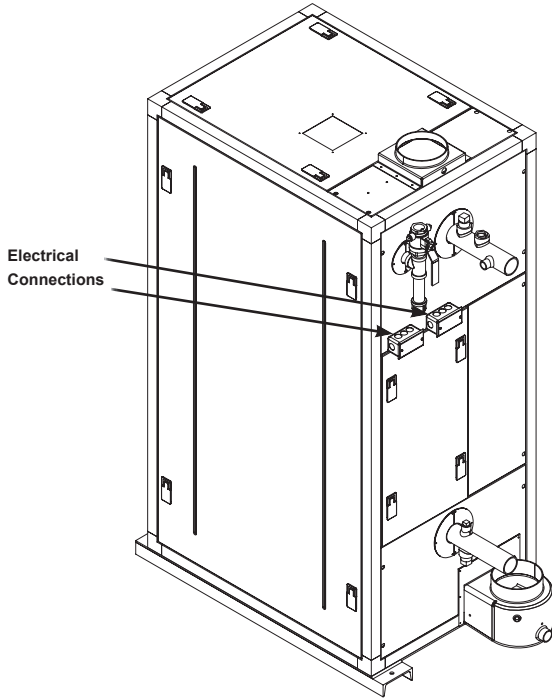

FIGURE 26—LINE VOLTAGE AND LOW VOLTAGE JUNCTION BOX LOCATIONS (TYPICAL)

■ Electrical and Controls Options

The electrical and controls options required and supplied will vary depending on the unique requirements and piping arrangements of the hydronic system. Refer to the separate Technical Data Sheet or Manual of each device for additional instructions. See **Electrical Schematic Diagrams** for locations of field wiring connections on the below electrical devices and controls options. Refer to the separate **Technical Data Sheet** or **Manual** of each device for additional instructions.

The rating of each external device contact is the maximum allowable amperage of the contact. The total Full Load Amps (FLA) of external devices wired to the boiler power circuit cannot exceed 1A.

► LEAD/LAG INTEGRATED SEQUENCING WIRING

1. The Fulton PURE Control™ includes integrated sequencing capabilities. When utilized, the boiler control system will automatically stage boilers and operate burner firing rates in parallel as necessary to maintain a hydronic setpoint.

2. The lead boiler and all lag boilers are rotated automatically.
3. The supply header temperature sensor is used as the Lead/Lag process variable and is required. Wire the sensor to a boiler "Header RTD Supply" connection and install downstream of the boilers in the common supply water header for proper operation of the sequenced plant.
4. Additional devices and sensors may be required, and will vary by application.
5. Communication between the boilers is performed using an Ethernet/IP network field wired with Cat5e or Cat6 cabling. An 8P8C ("RJ45") female connector port is provided on the boiler. Two boilers may be directly connected. For installations of 3 to 10 boilers a 10/100 Ethernet switch is required.
6. See the **Operation** section for information on programming this feature.
7. Available as an option from the factory is a 16-port Ethernet switch with a 120VAC power adapter using a standard NEMA 1-15 plug, this device is intended for field installation in a clean dry area such as a networking closet, rack, or panel enclosure. For complete instructions, refer to the **Technical Data** sheet for 2-45-315010 prior to installation.

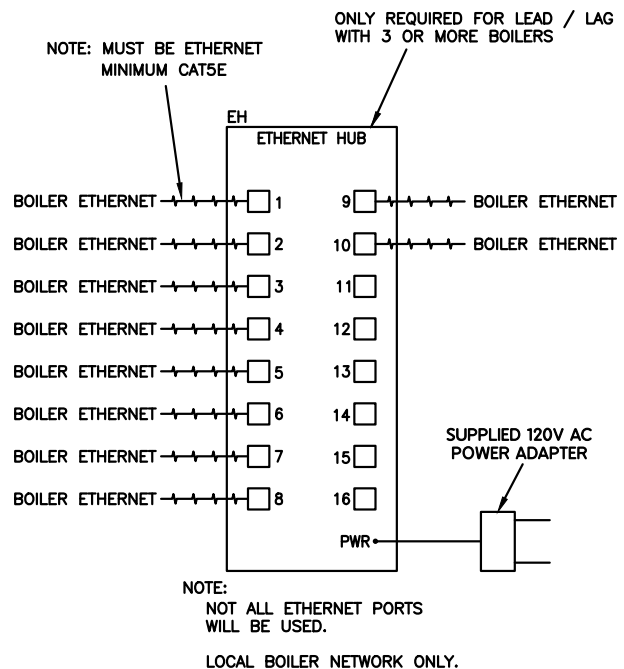

FIGURE 27 - ETHERNET-IP FIELD WIRING FOR 2-45-315010

8. Also available as an alternative option from the factory is a 5-port 24VDC Ethernet switch that may be field DIN rail mounted inside of the boiler cabinet. For complete instructions, refer to the **Technical Data** sheet for 2-45-315044 prior to installation.
9. Refer to the **Hydronic PURE Control™ User Manual for complete** instructions.

► INTEGRATION WITH THE MODSYNC SEQUENCING SYSTEM

Reference the **User Manual** and Electrical Schematic for the ModSync Sequencing System. Communication requires shielded three-wire twisted Belden 3106A or equivalent. Shield must be grounded at one end only and tied directly to Earth ground.

► SUPPLER HEADER TEMPERATURE SENSOR

1. A hydronic supply sensor and 1/2" NPT well (Part # 4-30-000510) is used for temperature control. This is a 3-wire PT100 RTD with Class B tolerance.
2. This sensor is required for any multiple boiler installation utilizing the integrated sequencing (lead/lag) capabilities.
3. This sensor is required for single boiler installations with primary-secondary piping arrangements to monitor the secondary (system) loop.
4. The sensor monitors hydronic loop temperature in the common supply piping as a process variable for sequencing and modulation purposes. The control uses this information when comparing actual loop temperature to setpoint.
5. It is field installed downstream of the boilers in the common supply water header. The well must be directly in the path of flow and not isolated with a valve to provide an accurate temperature reading. Do not install the supply header temperature sensor in the return water header.
6. See Figures 4 – 7 for the proper installation location in hydronic piping.
7. When extending the wire lead, use 18 to 22awg twisted 3 conductor stranded copper with insulated jacket. Ensure connections are tight with no shorts. Soldered and heat shrink tubing connections are recommended. Never use wire nuts to join lead to extension.

8. If the System Supply value becomes unavailable across the Universal Data system, boilers configured for Lead/Lag will lack a process variable and will automatically failsafe to local temperature control operation. For added redundancy, one or more additional header sensors may be wired to additional boilers in the Lead/Lag plant and configured as Local Network Providers of System Supply.
9. For complete instructions, refer to the **Technical Data** sheet for 4-30-000510 prior to installation.

► OUTDOOR AIR TEMPERATURE SENSOR KIT

1. If outdoor air temperature reset capabilities are to be utilized, an outdoor air temperature sensor kit (PN 4-30-000500) is required and field wired to a boiler. This is a 3-wire PT100 RTD with Class B tolerance.
2. An outdoor air temperature sensor kit is not required if using fixed water temperature operation, or if the boiler control is receiving an external hydronic setpoint signal over a communication protocol or analog signal.
3. The sensor must be installed on a north facing exterior wall, in a location that will not be exposed to direct sunlight or influenced by other mechanical equipment.
4. Mount in the vertical position, sensor sheath pointing downward.
5. When extending the wire lead, use 18 to 22awg twisted 3 conductor stranded copper with insulated jacket. Ensure connections are tight with no shorts. Soldered and heat shrink tubing connections are recommended. Never use wire nuts to join lead to extension.
6. For complete instructions, refer to the **Technical Data** sheet for 4-30-000500 prior to installation.

▶ DOMESTIC HOT WATER (DHW) TEMPERATURE SENSOR

1. This boiler is capable of providing indirect domestic hot water through a heat exchanger. A domestic hot water temperature sensor (PN 4-30-315300) is used for this application. The boiler is for closed loop applications only; open loop must not be directly heated by the boiler.
2. The sensor may be installed in the domestic hot water constant recirculation supply piping, or the domestic hot water storage tank.
3. See the **Operation** section for programming DHW priority. Refer to the **Hydronic PURE Control™ User Manual** for complete instructions.
4. When extending the wire lead, use 18 to 22awg twisted 2 conductor stranded copper with insulated jacket. Ensure connections are tight with no shorts. Soldered and heat shrink tubing connections are recommended. Never use wire nuts to join lead to extension.
5. For complete instructions, refer to the **Technical Data** sheet for 4-30-315300 prior to installation.

▶ MOTORIZED ISOLATION VALVE CONTROL

1. A control relay is provided as standard in the boiler control panel to operate a two-position motorized isolation valve. Contacts are rated for up to 30A at 24V or 120V. The valve type may be either power-open / power-close, power-open / spring-close, or spring-open / power-close. Do not power the actuator using the boiler control power supplies.
2. Select a valve actuator with a cycle time from close to open, and open to close, of 45 seconds or less. Do not use slower valve actuators as they may result in system issues such as manual reset lockouts or poor temperature control response.
3. A motorized isolation valve is used in variable primary piping arrangements, in accordance with ASHRAE 90.1-2013, to prevent flow from traveling through idle boilers.
4. The lead boiler motorized isolation valve must be field programmed to remain open when all boilers are idle to provide a path of flow in the hydronic system. See the **Operation** section for programming motorized isolation valve control. Refer to the **Hydronic PURE Control™ User Manual** for complete instructions.

▶ AUXILIARY SAFETY INTERLOCK FOR EXTERNAL DEVICE

1. When the boiler receives a call for heat, the startup sequence first checks for a completed interlock circuit. If the circuit is open, the boiler control will not begin ignition sequence until it is closed.
2. A jumper is factory installed in the interlock circuit. For applications requiring a safety interlock, this jumper may be removed with terminals wired into the dry contacts of an external device.
3. The interlock contacts provide a 24 VDC signal. **Do not apply an external power source to the interlock contacts; wire only to dry contacts.**
4. Typical uses for the safety interlock include but are not limited to: motorized isolation valve end switches, proof of exhaust draft assist fan operation, motorized air intake louvers.
5. Multiple safety interlocks may be used, wired in series.
6. Interlocks may be renamed for simpler troubleshooting.

▶ VARIABLE SPEED SYSTEM PUMP CONTROL

1. The boiler controller provides start/stop and variable speed control for two system (secondary) pumps, one duty plus one backup, with automation rotation. The pumps cannot be powered directly through the boiler panel; a variable speed drive (not provided) is required.
2. Pump modulation is provided via a 0-10 VDC output signal for each pump.
3. The pump start/stop contacts have a maximum rating of 6 Amps at 120 VAC.

▶ DEDICATED BOILER PUMP CONTROL

1. Some installations may utilize primary-secondary piping arrangements instead of variable primary piping arrangements. In these instances, the boiler (primary) loop is decoupled from the system (secondary) loop, and a dedicated boiler pump will be required to provide flow through the boiler.
2. The boiler controller provides a dedicated boiler pump start/stop signal only; the pump cannot be powered through the boiler panel. An external motor starter or variable speed drive (not provided) is required to control the circulator pump.
3. The pump contact has a maximum rating of 6 Amps at 120 VAC.
4. Can be modulated only if system pump feature is not used. A 0-10 VDC output is provided.

▶ ALTERNATE COMMUNICATION PROTOCOL GATEWAY

Reference the **Protonode Start-Up Guide** for for BACnet protocol.

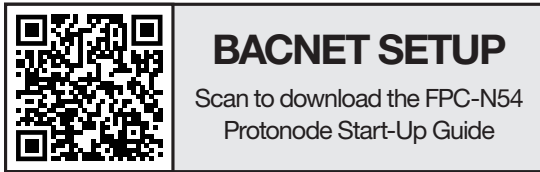

Communication between the boilers and the Protonode requires shielded three-wire twisted Belden 3106A or equivalent. To access the full points list of each boiler, the Modbus side of the Protonode wiring must be daisy-chained to all boilers. Shield must be grounded at one end only and tied directly to Earth ground. The Protonode may be powered by the 24VDC power supply in the boiler (V1+, V1-) or the power may be supplied by the Building Automation System. The Protonode requires field configuration through the Web GUI after installation.

▶ REMOTE BOILER ENABLE/DISABLE

1. A contact may be utilized to enable and disable each boiler individually. Remove the jumper and wire to remote control panel.
2. Closing the contact enables the boiler to start. When the contact is open, the boiler will remain in a disabled state.

▶ REMOTE ANALOG SETPOINT

1. An external hydronic loop setpoint signal may be sent using an analog signal. This may be either 4-20 mA or 0-10 VDC.
2. When using integrated lead/lag functionality, the setpoint signal may be sent to one boiler only.

▶ GENERAL ALARM CONTACT

A dry contact is provided for annunciation of a general alarm condition. It is rated for 6 Amps maximum.

▶ AUXILIARY(2ND) LOW WATER CUT OFF

1. This hydronic boiler includes one factory installed low water cut off (LWCO) device in compliance with CSD-1. Some authorities having jurisdiction (AHJ) may require the use of a 2nd (auxiliary) LWCO.
2. Where required, a probe type LWCO (P/N 4-30-000330) may be installed in the outlet piping of the boiler. The probe must not be isolated from the boiler by any valve.
3. Remove the jumper, and wire the external LWCO to the associated terminals. Install the LWCO relay.
4. Alternate LWCO devices may be used. They are wired to the same terminal blocks.

▶ FIELD DRAFT CONTROL SYSTEM

1. For connection to a field supplied mechanical draft control system which requires an enable signal from the boiler, install a 24VDC relay (not provided) to the UID-W1616R Module 4 digital output 14 contact. PURE Control v3.2.0.0 or later is required.
2. Do not use "Boiler Demand" or "Boiler Status" field connection contacts to enable a remote draft control system. These contacts are not suitable for this purpose.
3. This boiler includes devices which have been tested and certified to safely shutdown the burner in the event of an obstructed or blocked flue gas exhaust vent, including a draft system not satisfying the operating requirements of the boiler for safe performance. Therefore, wiring the draft control system to the boiler interlock circuit is not required. Where an interlock is required by the AHJ, wire in series to the LMV X3.02.1 to X3.02.2 air switch circuit. This is a 120VAC circuit, therefore ensure the draft control system provides a dry contact suitable for 120VAC. The draft system must close the interlock contact within 30 seconds of being enabled. Opening the interlock circuit during run will result in a manual reset lockout alarm.
4. LMV timings may require adjustment depending on the manufacturer, type, and installation of the draft control system. Consult the draft control provider and Fulton technical service for further support.

 **WARNING**

All information in this manual is for reference and guidance purposes, and does not substitute for required professional training, conduct, and strict adherence to applicable jurisdictional/professional codes and regulations.

▶ BOILER STATUS CONTACT

A dry contact is provided for remote monitoring of boiler status. When the main gas valve is enabled, the contact is closed.

▶ BOILER DEMAND CONTACT

A dry contact is provided for remote monitoring of boiler demand. When the boiler has a call for heat, the contact is closed.

▶ EMERGENCY STOP (E-STOP)

1. A contact is provided to perform an emergency shutdown of the boiler. Remove the jumper and wire to an emergency shutdown switch or remote control panel.
2. Opening the contact will shut down the boiler.
3. The E-Stop contact provides a 120 VAC signal. **Do not apply an external power source to the E-Stop contacts; wire only to dry contacts.**

INTRODUCTION

1

INSTALLATION

2

OPERATION

3

MAINTENANCE

4

SERVICE DOCUMENTS

5

⚠ WARNING

All information in this manual is for reference and guidance purposes, and does not substitute for required professional training, conduct, and strict adherence to applicable jurisdictional/professional codes and regulations. Failure to follow instructions may result in a fire or explosion, causing property damage, personal injury, or loss of life.

This boiler is equipped with an ignition device, which automatically lights the burner. Do not try to light the burner by hand.

Do not store or use gasoline or other flammable vapors and liquids in the vicinity of this or any other appliances.

*Use only your hand to turn the valve handle. Never use tools. If the knob will not turn by hand, don't try to repair it. Call a qualified service technician. **FORCE OR ATTEMPTED REPAIR MAY RESULT IN A FIRE OR EXPLOSION.***

WHAT TO DO IF YOU SMELL GAS • Do not try to light any appliance. • Do not touch any electrical switch; do not use any phone in your building. • Immediately call your gas supplier from a neighbor's phone. Follow the gas supplier's instructions. • If you cannot reach your gas supplier, call the fire department.

A qualified installer, service agency or the gas supplier, must perform installation and service.

Do not use this boiler if any part has been under water. Immediately call a qualified service technician to inspect the boiler and to replace any impacted part of the control system.

Perform Pre-Start-Up Inspection

Prior to start-up, perform the following:

1. If you smell gas:
 - Do not try to light any appliance.
 - Do not touch any electrical switch; do not use any phone in your building.
 - Immediately call your gas supplier from a neighbor's phone.
2. Ensure the boiler is located with the proper clearances as shown in the **Clearances and Serviceability** section of this manual.
3. Ensure that relief valves have been properly piped to floor drains.
4. Ensure flue gas from the boiler is properly vented.
5. Ensure the water system has been flushed and is free of debris.
6. Ensure combustion air openings are not obstructed in any way and have adequate capacity.
7. Ensure there are no flammable liquids, materials or hazardous fumes present in the environment.
8. Ensure nothing was damaged or knocked loose during installation and/or shipment.
9. Inspect the main gas train and trim assembly to be sure they were not damaged during shipment and/or installation.

Fill and Purge the System

Completely fill and purge the heating system as follows:

1. Close combination shutoff/purge valve in supply, all drain cocks, the shutoff valve for the pressure reducing (fill) valve, and all manual air vents.
2. Open a system valve, or fill through a drain connection.
3. Water will now begin to fill the system. Open the safety relief valve. Continue filling until a constant stream of water (no bubbling) is discharged from the safety relief valve.
4. At this point, the system has been initially filled. However, air pockets may still remain at high points in the system and in heating loops above the level of the safety relief valve. It is quite possible, depending on the particular system that all piping above the safety relief valve still contains air. If manual vents are installed on the system high points, these should be opened to vent these locations. When only water is discharged from all vents, the initial purging is complete.
5. With the gas shutoff valve closed, turn on power to the boiler and operate the circulator. Circulate the system water for approximately 30 minutes to move all air to the automatic air separation point.
6. Check temperature/pressure indicator reading, which should equal the pressure-reducing (fill) valve set pressure. No more water should be entering the system. Close the shutoff valve on the cold-water fill line.

7. Visually inspect all pipe joints and equipment connections for leaks. If necessary, drain system, repair leaks and refill/purge the system. If no pressure drop is detected for a period of two hours under pressure, the system may be considered watertight.
8. When purging is completed, make sure the following are open— combination shut-off/purge valve, shutoff valve to pressure reducing (fill valve), shutoff valve in cold water fill line, and shutoff valve in return line.
9. Make sure the following are closed - all drain cocks, the vent on the combination shutoff-purge valve, & all manual vents. Reset zone valves to normal mode of operation and turn off power to boiler.
10. Open fuel shutoff valve, allowing fuel to flow to boiler.

Commission The Boiler

Adhere to the following when commissioning the boiler:

1. Verify with authorized personnel that the gas lines have been purged and leak tested. Do not proceed without verification.
 2. Familiarize all personnel on all aspects of boiler use, safety, and contents of this manual. This includes, but is not limited to, the use of the controls, lighting, and shutdown procedures.
 3. Review the unit-specific burner and control schematics, and follow appropriate instructions.
- **NOTE:** *Warranty coverage is valid only if the boiler is commissioned (“started up”) by a factory authorized service technician with a valid Certificate of Authorization. The commissioning agency must successfully complete and return the Installation and Operation Checklist report (“Start-up Report”) to Fulton within twelve (12) weeks of start-up. Combustion and maintenance records detailing compliance with the Installation, Operation and Maintenance manual must be produced for warranty consideration.*

■ System Design and Boiler Operation

The boiler must be installed in an appropriately designed system per **Installation** section of this manual.

1. The boiler shall be operated/controlled to ensure the boiler does not cycle more than 12,000 times per year and the temperature differential across the boiler does not exceed 100°F (56°C).
2. Site specific conditions including combustion air temperature, elevation, fuel temperature, calorific value of the fuel, combustion air system design, exhaust system design, voltage fluctuations and other factors will impact boiler performance.
3. Performance factors affected may include but are not limited to input/output ratings, efficiency, modulation rates and emissions.
4. The Fulton factory Test Fire Report should be used as a point of reference in commissioning settings for the boilers in the field, however a factory certified service technician should account for all site conditions when finalizing operational settings.



WARNING

Do not attempt to start the boiler for any testing before filling and purging the boiler. A dry fire will seriously damage the boiler and may result in property damage or personnel injury and is not covered by warranty.

Before commissioning the boiler, verify with authorized personnel that the gas lines have been purged.

Never attempt to operate a boiler that has failed to pass all the safety checks.



CAUTION

Do not use this equipment if any part has been under water or subjected to heavy rains/water. Immediately call a qualified service technician to inspect the equipment and to replace any part of the control system and/or gas control(s) which have been under water.

The thermal shock warranty does not cover damage due to cyclic fatigue.

Never leave an opened manual air vent unattended. In the event an opened vent is left unattended, water damage could occur.



NOTE

Turndown: *Wind effects on combustion air supply and exhaust terminations, natural draft “stack effect”, and gas delivery systems (among other site factors) will ultimately determine what turndown settings are optimal for each application. Use a calibrated gas flow meter (not supplied) to measure burner input rates. Consult your local manufacturer’s representative or service organization with factory authorization specific to the Endura product line for guidance.*

Adjusting and Verifying Combustion

This boiler features Fulton's Flame-by-Wire® electronic air-fuel ratio combustion control with integrated O2 Compensation™ technology. These systems simplify start-up and maintenance, minimize energy use, and autonomously tune the burner air-fuel ratio, automatically optimizing for seasonality.

Correct initial air-fuel adjustment is essential for the efficient and reliable operation of any boiler. After installation and before placing the boiler into service, a qualified technician must perform a combustion analysis and adjustment as necessary, also known as combustion commissioning. Periodic analysis, adjustment, and verification of the combustion system per the schedule in the **Maintenance** section will ensure many years of safe and reliable service. The qualified technician holding a valid Certificate of Authorization should adhere to the following instructions.

■ Preparations Before Setting Combustion

1. Prepare a printed or digital copy of the appropriate form. Use the **Installation & Operation "Start-Up" Report (I&O)** when commissioning new equipment, and the **Annual Maintenance Checklist (MX)** for maintenance.
2. Prepare the required tools, refer to the **Tool List** in the **Maintenance** section for the complete list. At a minimum this will include a Slack Tube® or equivalent manometer, a Siemens AZL23 display and cable, a combustion analyzer, a digital multimeter, and necessary hand tools.
3. Wear proper Personal Protective Equipment (PPE) in accordance with site requirements.
4. Verify the boiler installation including fuel, power, venting, water pressure and flow are installed and operating in accordance with this manual. Ensure pumps and any motorized isolation valves are functional.
5. Open the front door of the boiler to gain access to necessary hardware and test port locations. Removal of additional cabinet panels may be necessary.
6. Verify the combustion analyzer is within calibration, inserted into the boiler flue gas vent test port and set to the proper fuel type. Insert the combustion analyzer a maximum of 2" (50 mm) into the test port. If inserted too far O2% readings may be unstable.

7. Record the static (boiler idle) incoming gas pressure at the test port location shown in Figure 8 and Figure 9. Incoming gas pressure is also referred to as supply, site, or inlet gas pressure.
8. Verify the software version is up to date. If a newer version of the software is available, update before continuing. Refer to the **PURE Control™ User Manual** for instruction.
9. Navigate to the Technician screen. A password is required which is provided to authorized technicians who have completed service training.
10. Configure the Venting Material and Site Elevation parameters per site criteria.
11. Confirm the boiler model and size are properly configured.

■ Lighting the Burner and Setting Combustion

► *NOTE: Commissioning the boiler on Propane (LPG) requires additional considerations. Do not operate a boiler pre-configured for Natural Gas on Propane, even for temporary heat, until an authorized technician has successfully completed the fuel conversion. Contact factory technical service prior to commissioning on Propane. Refer to Table 10 for Propane.*

1. Navigate to the PURE Control Commissioning screen.
2. Connect the AZL cable to the LMV3 flame safeguard and then connect the other end of the cable to the AZL.
3. Refer to the **Siemens LMV3 Control** section of this manual for instruction on using the AZL at the 400 parameter level.
4. Use the AZL to start the boiler and hold the burner at the low fire (P1) position.
5. Remove the brass cap on the Siemens SKP25 factory gas train main regulator. Use a flat blade screwdriver to adjust the MV Downstream pressure within compliance of Table 9. MV Downstream is measured at the ball valve test port directly downstream of the SKP25.
6. Re-install the brass cap. Adjustments to MV Downstream are only made at P1.

7. Do not set the P1 Gas Position to a lower degree than the value on the factory Test Fire Report. It is however acceptable to increase the Gas Position. To increase O₂% at P1 do not reduce the Gas Position, instead increase the Air Position and/or Blower Position.
 8. Verify minimum blower discharge pressures at P0 and P1 are met, increase the Blower Position(s) where necessary to account for site venting.
 9. To set Intake Manifold pressure, adjust the Air Position and/or Blower Position. Intake Manifold pressure is measured from the front of the air damper manifold assembly.
 10. After verifying Intake Manifold pressure, adjust the Gas Position to set O₂%.
 11. Measure, adjust and then verify all combustion curve points (P0-P9) meet the specifications in Table 9.
 12. Verify the dynamic (P9, high fire) incoming gas pressure meets both the range on the data plate at the rear of the boiler and does not drop more than 15% from the static incoming gas pressure measurement previously recorded. If an excessive incoming gas pressure drop is observed this is typically due to undersized field gas piping and/or an undersized field line pressure regulator. For reliable operation, the installing contractor must resolve gas pressure issues. Recommission the boiler after gas pressure issues are successfully resolved.
 13. After finishing combustion adjustment and verification tap the "Set O₂ Compensation Temperature Value" button on the boiler commissioning screen while the boiler is firing at the P9 (high fire) position. This will set the combustion air temperature value for the O₂ Compensation system.
 14. Carefully check for gas leaks along the field gas piping, factory gas train, pre-mix system (blower discharge region) and exhaust collection and disposal systems. A GAS-Mate® 0119 combustible gas detector or equivalent is recommended. The detection level must not exceed Level 1 (500 ppm), measurements below Level 1 are considered a safe and acceptable condition.
 15. Ensure all parameters at all points are documented on the I&O or MX form.
 16. Once commissioning is completed, tap on the "Complete Commissioning" button and stop the burner.
- ### ■ Verifying Safeties and Ignition Reliability
1. EDR-750/1000 Only: Verify the manifold Air Switch is set to -0.8"W.C.
 2. EDR-1500/2000 Only: Verify the manifold Air Switch is set to -0.4"W.C.
 3. Verify the Low Gas Pressure Switch is set between 3.0 to 5.0"W.C.
 4. Verify the High Gas Pressure Switch is set between 3.0 to 5.0"W.C.
 5. Verify Operating and High Limit Aquastat settings.
 6. Start the boiler and allow main flame to establish, then stop the boiler to disable the burner. Repeat this test a minimum of 10 consecutive times to verify reliable ignition.
- ### ■ Upon Successful Completion
1. Save PURE Control User Settings to the SD Card, refer to the **PURE Control User Manual**.
 2. Replace all test port plugs using the appropriate thread sealant.
 3. Re-install or close any open cabinet panels.
 4. Place the boiler into automatic operation and adjust setpoint to verify the boiler is responding accordingly with quiet, repeatable, and reliable combustion.
 5. Complete all remaining installation details, safety checks and measurements on the appropriate I&O or MX form. Do not skip this critically important step or leave fields blank. Maintaining accurate and complete records facilitates future service and troubleshooting.
 6. Leave a copy of the I&O or MX form with the boiler or the appropriate site contact. Retain a copy for your records in a safe location.
 7. For new equipment start-up, warranty coverage is valid only if the I&O form is successfully completed and returned to the Fulton factory service coordinator within twelve weeks of start-up.
- *NOTE: Accurate and complete combustion and maintenance records detailing compliance with the Installation, Operation and Maintenance manual must be produced for warranty consideration.*

Combustion Parameters

For safe, reliable, and efficient performance, operate the burner in accordance with the following combustion parameters:

TABLE 9 - NATURAL GAS COMBUSTION PARAMETERS

EDR-750		P0	P1	P2	P3	P4	P5-P6	P7-P8	P9
MV Downstream ²	"WC		1.95 to 2.05						
Fan Discharge ²	"WC	≥ 0.4	≥ 0.1						≤ 5.7
Manifold ²	"WC	-2.4	-2.5 to -3.5	-2.5 to -3.5	-2.5 to -3.5	-2.5 to -3.5	-2.5 to -3.5	-2.5 to -3.5	-2.5 to -3.5
O2 (Natural Gas)	%	4.9 to 5.3	8.3 to 7.9	7.3 to 7.7	7.3 to 7.7	6.6 to 7.0	5.8 to 6.2	5.8 to 6.2	5.8 to 6.2
Gas Position	Deg	≥ 21.9	≥ 12.5						≤ 49.8
Air Position	Deg	≥ 24.0	≥ 15.9						≤ 55.8
VSD Position	Deg	≥ 45.3	≥ 55.0						≤ 80.9

EDR-1000		P0	P1	P2	P3	P4	P5-P6	P7-P8	P9
MV Downstream ²	"WC		1.95 to 2.05						
Fan Discharge ²	"WC	≥ 0.4	≥ 0.1						≤ 10.6
Manifold ²	"WC	-2.1	-2.4 to -3.4	-2.8 to -3.8	-2.5 to -3.5	-2.5 to -3.5	-2.5 to -3.5	-2.5 to -3.5	-2.5 to -3.5
O2 (Natural Gas)	%	4.8 to 5.2	7.9 to 8.3	7.4 to 7.8	6.6 to 7.0	5.9 to 6.3	5.8 to 6.2	5.6 to 6.2	5.6 to 6.0
Gas Position	Deg	≥ 21.9	≥ 12.1						≤ 55.5
Air Position	Deg	≥ 28.6	≥ 19.5						≤ 64.0
VSD Position	Deg	≥ 41.6	≥ 53.4						≤ 97.0

EDR-1500		P0	P1	P2	P3	P4	P5-P6	P7-P8	P9
MV Downstream ²	"WC		2.75 to 2.85						
Fan Discharge ²	"WC	≥ 0.6	≥ 0.2						≤ 12.3
Manifold ²	"WC	-1.4 to -1.8	-1.4 to -1.8	-1.4 to -1.9	-1.4 to -1.8	-1.4 to -1.8	-1.5 to -1.9	-1.5 to -1.9	-1.5 to -1.9
O2 (Natural Gas)	%	5.3 to 5.7	8.6 to 9.0	6.5 to 6.9	6.4 to 6.8	6.3 to 6.7	6.2 to 6.6	6.0 to 6.5	6.0 to 6.4
Gas Position	Deg	≥ 14.8	≥ 8.0						≤ 45.7
Air Position	Deg	≥ 26.8	≥ 18.3						≤ 73.1
VSD Position	Deg	≥ 43.6	≥ 39.4						≤ 97.0

EDR-2000		P0	P1	P2	P3	P4	P5-P6	P7-P8	P9
MV Downstream ²	"WC		2.75 to 2.85						
Fan Discharge ²	"WC	≥ 0.4	≥ 0.1						≤ 12.3
Manifold ²	"WC	-1.5 to -1.9	-1.3 to -1.7	-1.5 to -1.9	-1.4 to -1.8	-1.4 to -1.8	-1.4 to -1.8	-1.4 to -1.8	-1.5 to -1.9
O2 (Natural Gas)	%	5.2 to 5.6	8.6 to 9.0	6.4 to 6.8	6.2 to 6.6	6.3 to 6.7	5.7 to 6.1	5.6 to 6.0	5.5 to 5.9
Gas Position	Deg	≥ 16.1	≥ 7.9						≤ 50.5
Air Position	Deg	≥ 30.5	≥ 18.1						≤ 87.0
VSD Position	Deg	≥ 34.5	≥ 38.8						≤ 97.0

Notes:

- 1) Never decrease gas position at P1, ensure minimum blower discharge is met.
- 2) Measurements should be recorded using a Slack Tube[®] manometer or equivalent. The use of a digital manometer is not recommended.
- 3) The commissioning technician must account for installation and location variances, such as venting arrangements, wind effects, elevation and emissions regulations, which will ultimately determine the appropriate settings for the application.
- 4) These parameters are for natural gas operation only.

TABLE 10 - PROPANE COMBUSTION PARAMETERS

EDR-750		P0	P1	P2	P3	P4	P5-P6	P7-P8	P9
MV Downstream ²	"WC		1.95 to 2.05						
Fan Discharge ²	"WC								≤ 5.1
Manifold ²	"WC	-1.9 to -2.3	-1.9 to -2.3	-1.9 to -2.3	-1.9 to -2.3	-1.9 to -2.3	-1.9 to -2.3	-1.9 to -2.3	-1.9 to -2.3
O2 (Propane)	%	4.1 to 4.5	6.8 to 7.2	6.6 to 7.0	6.5 to 6.9	6.4 to 6.8	6.2 to 6.7	6.2 to 6.7	6.1 to 6.6
Gas Position	Deg	≥ 19.2	≥ 18.9						≤ 40.1
Air Position	Deg	≥ 28.7	≥ 31.2						≤ 58.5
VSD Position	Deg	≥ 41.7	≥ 41.7						≤ 72.0

EDR-1000		P0	P1	P2	P3	P4	P5-P6	P7-P8	P9
MV Downstream ²	"WC		1.95 to 2.05						
Fan Discharge ²	"WC								≤ 9
Manifold ²	"WC	-1.9 to -2.3	-1.9 to -2.3	-1.9 to -2.3	-1.9 to -2.3	-1.9 to -2.3	-1.9 to -2.3	-1.9 to -2.3	-1.9 to -2.3
O2 (Propane)	%	4.1 to 4.5	6.8 to 7.2	6.6 to 7.0	6.5 to 6.9	6.4 to 6.8	6.2 to 6.7	5.8 to 6.2	5.3 to 5.7
Gas Position	Deg	≥ 19.2	≥ 18.9						≤ 46.5
Air Position	Deg	≥ 28.7	≥ 31.2						≤ 65.3
VSD Position	Deg	≥ 41.7	≥ 41.7						≤ 87.3

EDR-1500 Derate ⁵		P0	P1	P2	P3	P4	P5-P6	P7-P8	P9
MV Downstream ²	"WC		1.20 to 1.40						
Fan Discharge ²	"WC								≤ 9
Manifold ²	"WC	-2.9 to -3.3	-2.5 to -2.9	-2.6 to 3.0	-2.7 to -3.1	-2.7 to -3.1	-2.7 to -3.1	-2.7 to -3.1	-2.8 to -3.2
O2 (Propane)	%	3.2 to 3.6	6.8 to 7.2	6.6 to 7.0	6.4 to 6.8	6.1 to 6.5	5.8 to 6.4	5.6 to 6.1	5.5 to 5.9
Gas Position	Deg	≥ 18.2	≥ 18.2						≤ 32.2
Air Position	Deg	≥ 36.5	≥ 41.4						≤ 59.9
VSD Position	Deg	≥ 46.7	≥ 44.2						≤ 76.3

EDR-2000		P0	P1	P2	P3	P4	P5-P6	P7-P8	P9
MV Downstream ²	"WC		1.20 to 1.40						
Fan Discharge ²	"WC								≤ 14
Manifold ²	"WC	-2.9 to -3.3	-2.5 to -2.9	-2.7 to 3.2	-2.7 to 3.2	-2.7 to 3.2	-2.6 to -3.2	-2.7 to -3.1	-2.7 to 3.2
O2 (Propane)	%	3.2 to 3.6	6.8 to 7.2	6.5 to 6.9	6.1 to 6.5	5.9 to 6.3	5.5 to 6.1	5.3 to 5.8	5.0 to 5.4
Gas Position	Deg	≥ 18.2	≥ 18.2						≤ 38.0
Air Position	Deg	≥ 36.5	≥ 41.4						≤ 68.1
VSD Position	Deg	≥ 46.7	≥ 44.2						≤ 93.3

Notes:

- 1) Never decrease gas position at P1, ensure minimum blower discharge is met.
- 2) Measurements should be recorded using a Slack Tube® manometer or equivalent. The use of a digital manometer is not recommended.
- 3) The commissioning technician must account for installation and location variances, such as venting arrangements, wind effects, elevation and emissions regulations, which will ultimately determine the appropriate settings for the application.
- 4) These parameters are for propane operation only.
- 5) Listed parameters are for model EDR-2000 de-rated to 1,500 MBH input.

WARNING

Non-Fulton product information is for reference purposes only. No Fulton document should substitute for full review of documentation available from the component manufacturer.

CAUTION

Commissioning/Start up by a non-Fulton authorized person will void the product warranty.

Please read these instructions and post in an appropriate place near the equipment. Maintain in good legible condition.

When commissioning is complete, the control must be placed into automatic mode.

Never operate a natural gas configured boiler on propane, even for temporary heat. Boilers factory test fired on natural gas must be converted by an authorized service technician before operating on propane.

Siemens LMV3 Control









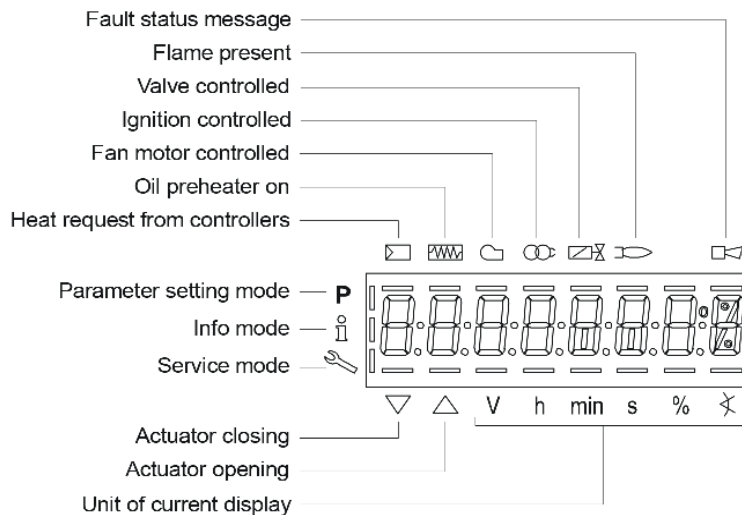
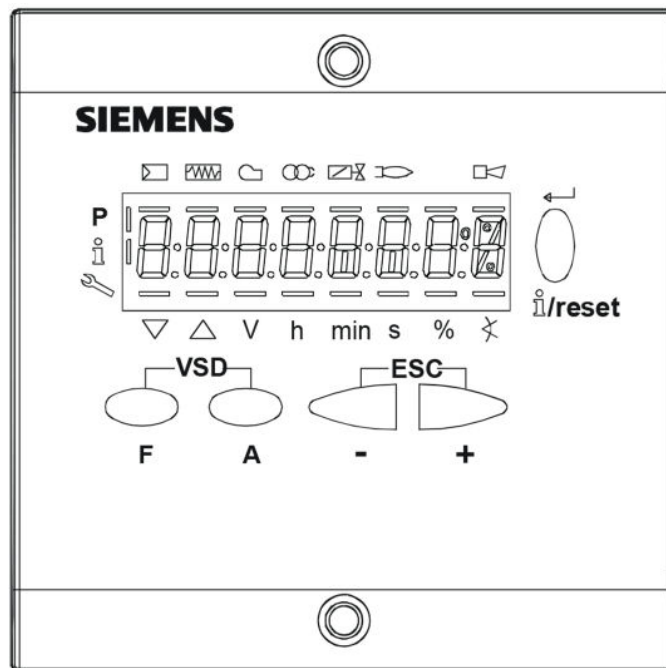







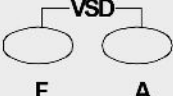

The Siemens LMV3 system is a fully packaged burner management system, linkageless control and first out annunciator.

A Siemens AZL display or ACS410 software will be required (not provided) for the authorized service technician to perform configuration of the LMV3.

The left and right arrow keys are used for scrolling through the menu and changing controller parameters. Pressing the *Enter* button accepts the menu and parameter changes. It is possible to return to the main menu at any time by repeatedly pressing ESC (*Escape*). See Figure 27.

FIGURE 27 - SIEMENS AZL DISPLAY

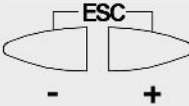

Button	Function
	Button F - For adjusting the fuel actuator (keep  depressed and adjust the value by pressing  or )
	Button A - For adjusting the air actuator (keep  depressed and adjust the value by pressing  or )
	Buttons A and F: VSD function - For changing to parameter setting mode P (press simultaneously  and  plus  or )
	Info and Enter button - For navigating in info or service mode * Selection (symbol flashing) (press button for <1 s) * For changing to a lower menu level (press button for 1...3 s) * For changing to a higher menu level (press button for 3...8 s) * For changing the operating mode (press button for >8 s) - Enter in parameter setting mode - Reset in the event of fault - One menu level down
	- button - For decreasing the value - For navigating during curve adjustments in info or service mode
	+ button - For increasing the value - For navigating during curve adjustments in info or service mode
	+ and - button: Escape function (press  and  simultaneously) - No adoption of value - One menu level up

■ Before Modifying LMV Parameters

The boiler must be placed in "Commissioning Mode" before modifying any LMV parameters. Set-up must be fully completed prior to automatic operation of the boiler.

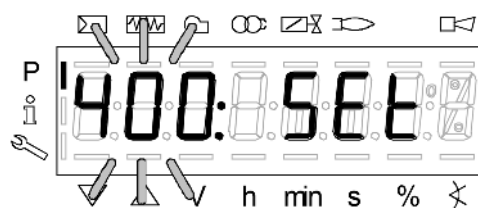
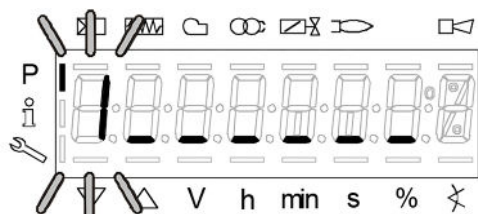
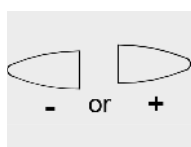
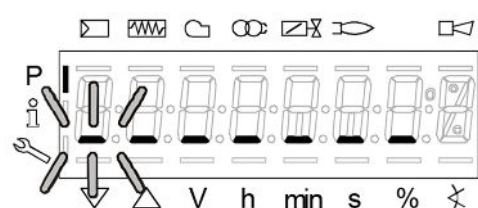
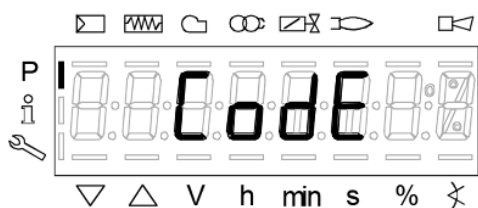
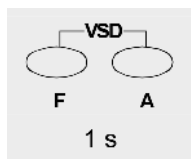

- 1) Press and hold the "F" and "A" buttons simultaneously.
 - a. "Code" will be displayed.
- 2) When releasing "F" and "A", 7 bars appear the first of which flashes.
- 3) Press the "-" or "+" button to select the first number of the national board number and press enter (i/reset) button after each selected number.

► **NOTE: The service password is "00000."**

- 4) After entry of the last number, the password must be confirmed by pressing enter (i/reset) button.
- 5) After correct entry of password, PArA appears for a maximum of 2 seconds.
- 6) Parameter 400 will flash.
 - a. Use the "-" or "+" button for scrolling to the desired parameter.
 - b. Press the enter (i/reset) button to enter the selected parameter level.

■ Adjusting Fuel/Air Curve

► **NOTE:** Fulton Endura boilers are factory test fired and pre-programmed with values in the fuel/air curve (P0-ignition to P9-high fire).

With the burner on, follow the below steps for making field changes to the fuel/air curve points. A calibrated flue gas analyzer is required to complete these steps and must be properly inserted into the boiler flue exhaust vent while making changes to the fuel/air curve points. The boiler controller must be placed in Commissioning Mode before making any adjustments.

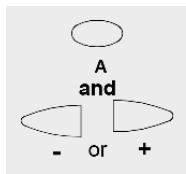
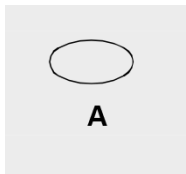
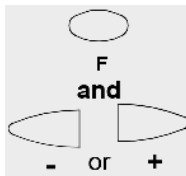
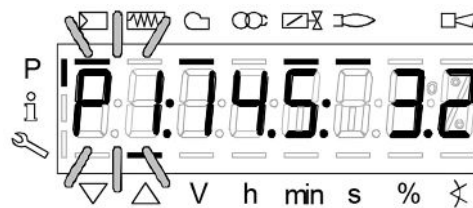
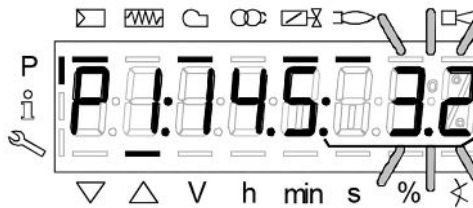
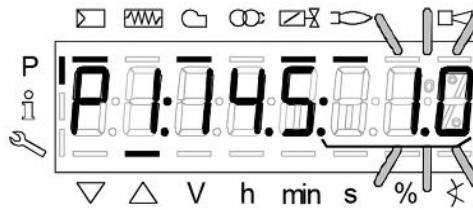
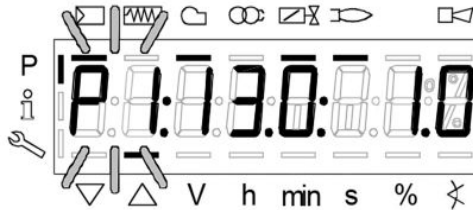
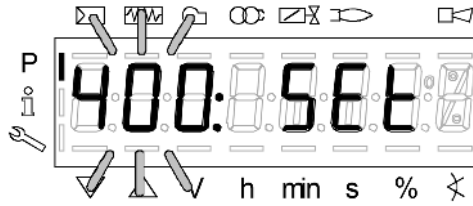

Steps to Enter Parameters

1) Confirm position of the fuel selection switch where applicable.

2) Enter the password and parameter "400" will flash.

3) Press the enter (i/reset) button 2 times.

a. "P1" will flash and the curve point will be displayed.

► **NOTE:** P0 is the ignition position. Verify proper combustion at the ignition position.

4) With "P1" flashing the fuel or air actuator may be individually selected for combustion adjustments.

a. For the fuel actuator keep the "F" button depressed and press the "-" or "+" button to adjust the fuel actuator.

i. Any changes are automatically saved.

ii. Release the "F" button.

b. For the air actuator keep the "A" button depressed and press the "-" or "+" button to adjust the air actuator.

i. Any changes are automatically saved.

ii. Release the "A" button.

c. With "P1" flashing use the "+" for the next curve point and the "-" for going back to the previous curve point.

d. Repeat steps "a." and "b." above if changes are required at any other curve point.

Manual Control (Manual Request for Output)

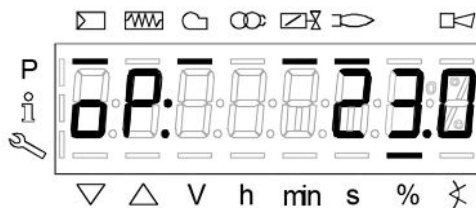
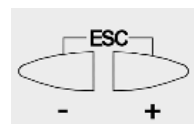
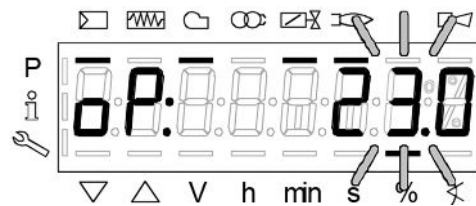
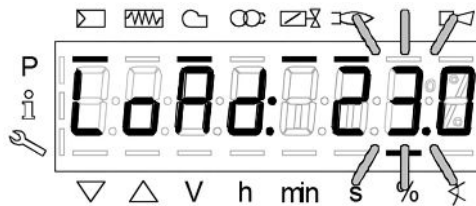
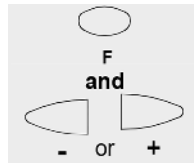
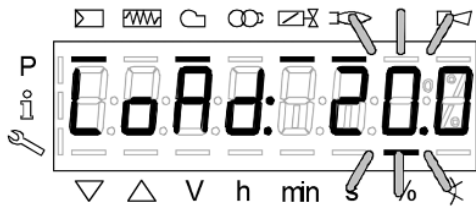
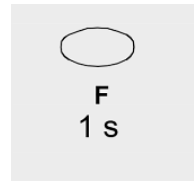
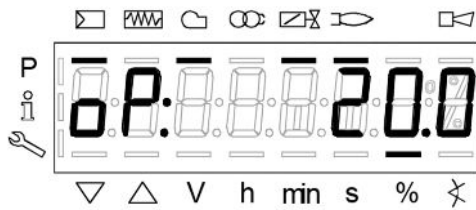

- 1) Burner is in operation mode.
 - a. The display shows oP: on the left, the percentage of the current output on the right.
- 2) Press and Hold the F button for 1 second.
 - a. The display shows LoAd; the current output flashes.
- 3) Still holding the F button press the – or + to adjust the required output in manual.
 - a. The display shows LoAd; still holding the F button the new output flashes.
- 4) Release the F button.
 - a. The current manual output flashes; oP: is still displayed on the left solid indicating that manual control is activated.
- 5) Press and hold the – and + for 3 seconds to return to automatic mode.
 - a. The output will no longer flash, oP: will be displayed on the left solid and the operating percentage will be displayed on the right.

Parameter Backup

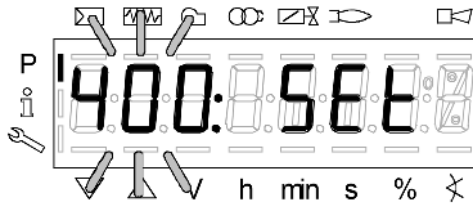

1. Press and hold "F" and "A" until Code is displayed.
 - a. Then enter unit national board number press enter once complete.

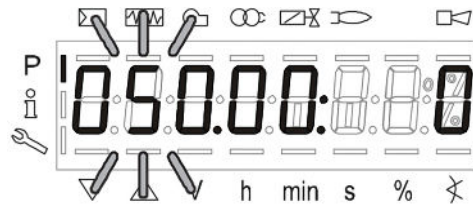

2. "400: Set" will be displayed
 - a. Press the "-" arrow three times until "000: Int" is displayed.
 - b. Press the Enter button to get into "100: Int" parameters.

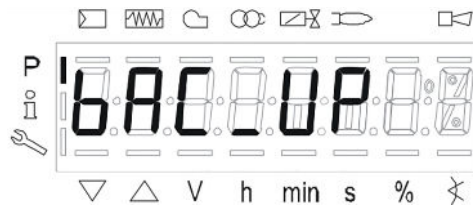

3. Backup procedure:
 - a. Press the "+" button and go to P-050 (050 will be flashing).
 - b. Press enter > bAC_uP is displayed.
 - c. Press enter > 0 is displayed.
 - d. Press "+" button and 1 is flashing
 - e. Press enter, after about 5 seconds a 0 appears on the display indicating the end of the backup process.

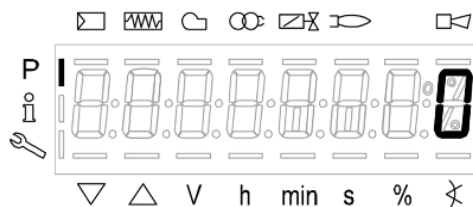

- **NOTE:** If an error occurs during the backup process, a negative value is displayed. For troubleshooting, go to error code 137 to view diagnostic code.

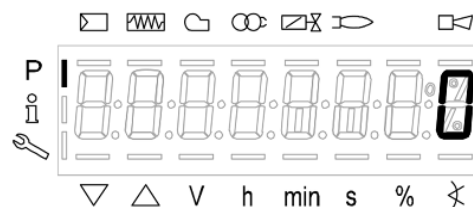
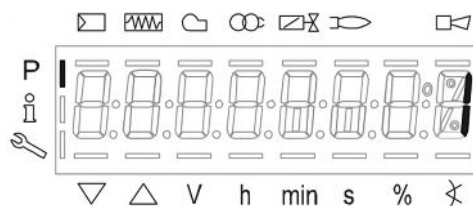

Approx.
5 s

Parameter Restore

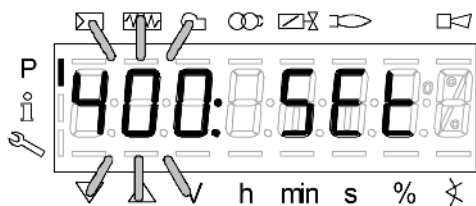

1. Press and hold "F and A" until Code is displayed
 - a. Then enter unit national board number press enter once complete.
2. "400: Set" will be displayed

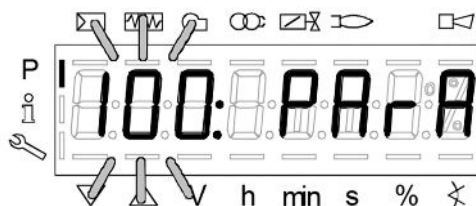

- a. Press the "-" arrow two times until "100: PAR A" is displayed.
- b. Press the Enter button to get into "100" parameters.
- c. Press the "+" arrow until parameter 113 is reach enter into the parameter and record the Burner ID#.
- d. This is required for performing the Restore process.

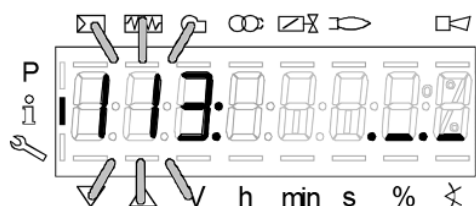

3. Restore procedure:
 - a. Go to "000: Int" parameter enter in and go to P-050 (050 will be flashing).

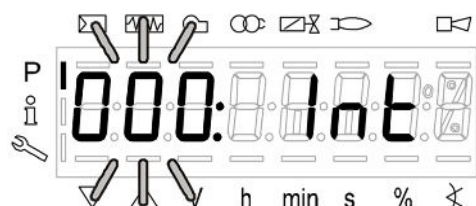

- b. Press enter > bAC_uP is displayed.
- c. Press "+" button to select "rEstorE".
- d. Press enter > 0 is displayed.
- e. Press "+" button and 1 is flashing

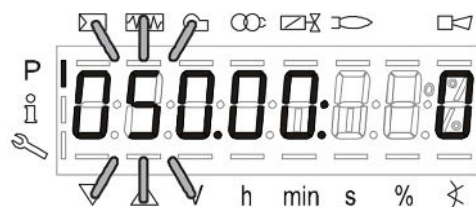
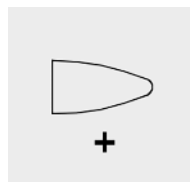

- **NOTE:** If an error occurs during the Restore process, a negative value is displayed. For troubleshooting, go to error code 137 to view diagnostic code.

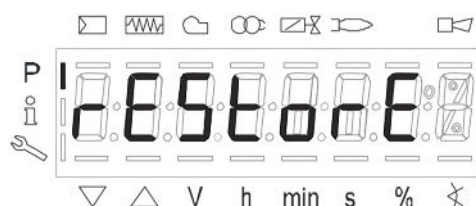
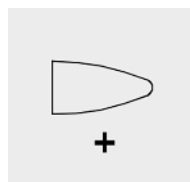
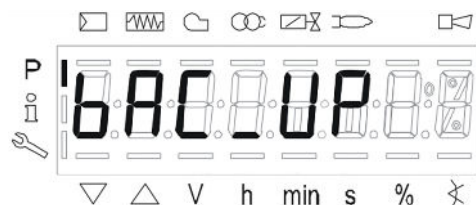

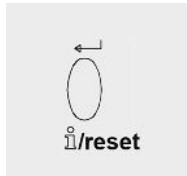

Approx.
5 s

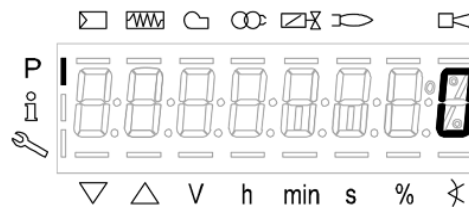
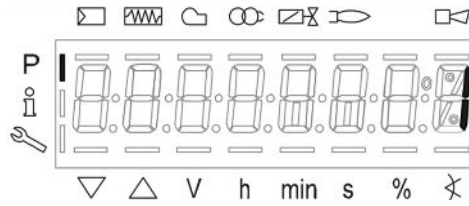
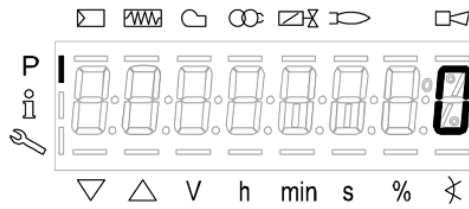

WARNING

All information in this manual is for reference and guidance purposes, and does not substitute for required professional training, conduct, and strict adherence to applicable jurisdictional/professional codes and regulations.

Non-Fulton product information is for reference purposes only. No Fulton document should substitute for full review of documentation available from the component manufacturer.

WARNING

All information in this manual is for reference and guidance purposes, and does not substitute for required professional training, conduct, and strict adherence to applicable jurisdictional/professional codes and regulations.

Non-Fulton product information is for reference purposes only. No Fulton document may substitute for full review of documentation available from the component manufacturer.

CAUTION

A temperature exceeding 104°F** (40 C) in the boiler room may cause premature failure of electrical components. Provisions should be made to maintain an ambient temperature of 104°F** (40 C) or less.

**Pumps, PLC or ModSync panels may require lower ambient temperatures or additional cooling.

This hydronic heating boiler is not suitable for use as a domestic water heater. Do not heat potable water, such as used for showers, sinks, dishwashers, or washdown process directly through the boiler.

Using the PURE Control® Interface

Reference the **PURE Control User Manual** for detailed instructions on the controls system. The boiler control system features an integrated color touchscreen display through which many commissioning and operation tasks are performed, including temperature control and lead-lag configuration. The graphical interface is navigated by touch using your finger or a stylus. The screenshots and information in this section will guide you through the menu screens.



ENDURA PURE CONTROL USER MANUAL

Scan to download the Endura PURE Control User Manual

■ Navigation

The Main Menu (“Dashboard”) groups screens where functions are accessed into the following categories: Boiler, Lead/Lag, PID, Temperature, Circulation, Alarm History, Configuration and Tech Tools. To enter a category, tap the tile. The Boiler and Alarm History tiles are live, and will display operating information when applicable.

While on a screen, return to the Main Menu at any time by clicking the menu button located at the top left. While on the Main Menu, return to the screen in use by tapping the X button located at the top left.

Screens are context sensitive for ease of use, meaning selections made will dynamically change the user interface and display relevant functions.

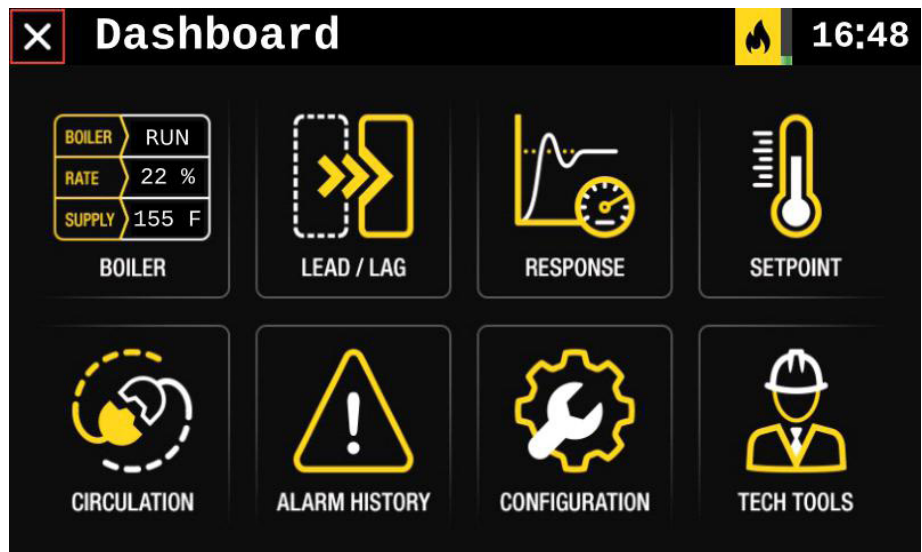

PURE Control® Menu Screens

■ Boiler

General individual boiler and ancillary functionality is accessed through this category.

▶ STATUS

Summarizes detailed operating information and sensor status for the boiler.

▶ DEMAND

Devices will either have a green circle to the left indicating closed circuit or a red circle indicating the device is open. The device indicated as the "open limit" is the first device in the safety circuit open and should be the first device addressed during troubleshooting.

Call for heat requires at least one condition to be green. If all are gray, the boiler will remain in an idle (standby) condition.

▶ CONTROL

When in Automatic Control, the temperature controller will modulate the burner to a firing rate necessary to achieve the setpoint. To enter Manual Control, tap the "Automatic Control" button, and it will change to "Manual Control." Enter a "Manual Firing Rate" in the box, and press OK to confirm. When finished with maintenance or testing, return to this screen and place the boiler back into Automatic Control.

▶ HISTORY

Various data points of operational history including run hours, power-on hours, cycles, and estimated (calculated) efficiency are summarized on this screen.

■ Alarm History

This screen provides a chronological list of alarms. Pressing the "View Alarm Info" button will expand a selected alarm for additional information and troubleshooting tips.

■ Circulation

Contacts are provided for a boiler motorized isolation valve, a primary (dedicated boiler) pump or secondary (system) pumps, and a domestic hot water (DHW) pump.

Each contact may be placed in manual control or automatic. In automatic control, a Close Delay Timer can be set to keep the boiler valve or boiler pump contact closed for the prescribed time when a boiler no longer has a call for heat. The Delta T Close Delay feature will hold the contact closed until residual heat is removed from the heat exchanger and the Delta T drops to the selected value. When enabled, both



WARNING

All information in this manual is for reference and guidance purposes, and does not substitute for required professional training, conduct, and strict adherence to applicable jurisdictional/professional codes and regulations.

Non-Fulton product information is for reference purposes only. No Fulton document should substitute for full review of documentation available from the component manufacturer.

WARNING

All information in this manual is for reference and guidance purposes, and does not substitute for required professional training, conduct, and strict adherence to applicable jurisdictional/professional codes and regulations.

Non-Fulton product information is for reference purposes only. No Fulton document should substitute for full review of documentation available from the component manufacturer.

conditions must be satisfied. For variable primary flow applications utilizing motorized isolation valves, select to enable one contact to always remain closed when lead/lag is used.

The primary (dedicated boiler) pump contact closes upon local burner demand, and opens upon the prescribed delay settings.

The secondary (system) pump contact is closed at all times while the boiler plant is enabled and allowed to run, even while no burners are operating. This contact opens upon the prescribed delay settings. The boiler pump function is disabled when the system pump function is utilized. System pump control features duty/standby and PID speed control functionality. Refer to the User Manual for details.

The DHW pump contact closes upon DHW heat demand, and opens upon the prescribed delay settings.

■ Lead/Lag

▶ CONFIGURATION

Integrated multiple boiler sequencing “Lead/Lag” is configured and monitored through this category. Ensure the boilers are on a private Ethernet/IP network shared with no other devices before continuing setup.

To function properly on the network, the **Local Ethernet/IP Address** of each boiler must be configured per the following:

Boiler 1 – 192.168.1.100	Boiler 6 – 192.168.1.105
Boiler 2 – 192.168.1.101	Boiler 7 – 192.168.1.106
Boiler 3 – 192.168.1.102	Boiler 8 – 192.168.1.107
Boiler 4 – 192.168.1.103	Boiler 9 – 192.168.1.108
Boiler 5 – 192.168.1.104	Boiler 10 – 192.168.1.109

Wire the boiler in accordance with the instructions detailed in the Installation section. Wiring for the Ethernet/IP network will change based on the number of boilers in the system. For systems with two boilers, a single Ethernet cable can be wired directly between the boilers. For systems with more than two boilers, each boiler will require an Ethernet home run back to the Ethernet switch (ships loose in trim kit when ordered).

Set the Number of Boilers field to the number of boilers to be controlled. These steps must be completed at each boiler. Ensure the **Universal Data**, is properly configured for data sources.

- *Lead/Lag priority* determines how the boilers are sequenced, either by cycles only, hours only, or an optimized algorithm.
- *Number of boilers* displays how many boilers the Lead/Lag system expects to have under control.
- *Lead start* is how far below setpoint before the lead boiler turns on.
- *Lead stop* is how far above setpoint before the lead boiler turns off.

► COMMUNICATION

View the status of lead/lag network communication.

► UNIVERSAL DATA

The Universal Data system allows the boilers to share vital data over the Ethernet/IP Boiler Network without having to wire individual sensors to each boiler, or write commands to each boiler. Configure the Universal Data sources at each boiler, for that specific boiler.

- Physically Wired – The control will look to its own I/O inputs for the information it needs and will then share that information with the Boiler Network.
- Boiler Network – The control will look to the local Ethernet/IP network for the information it needs. In order for this to work, one boiler will need to share that information with the network setup as either physically wired or BMS network.
- BMS Network – The control will look to the Building Management Network for the information that it needs and will share it with the rest of the boiler network.
- Please note that each signal/sensor can be independently configured, meaning one boiler could provide a setpoint to the boiler network, and another could provide the system header temperature, for instance.

■ PID

Proportional Integral Derivative (PID) control is used to modulate the burner or burners as a response to heat demand in the system. Proper setup of the PID specific to your application is necessary and will directly impact temperature response. In typical applications a full-passive response is desired, this will reduce boiler cycling, reduce maintenance, and prevent temperature overshoots.

The Local PID slider is used for local demands, when the boiler is operating in standalone mode.

The Lead/Lag PID is used when utilizing the integrated Lead/Lag functionality. Ensure the Lead/Lag PID is configured to the same setting on each boiler in the plant, failure to do so many result in unexpected temperature response when the Network Originator changes.

Local PID and firing rate modifiers are accessed in this category.

► PID OVERRIDES

Low Fire Hold will lock the burner at a low fire rate after ignition for a set period of time.

Two stages of freeze protection are provided. Stage 1 is only available if the boiler



WARNING

All information in this manual is for reference and guidance purposes, and does not substitute for required professional training, conduct, and strict adherence to applicable jurisdictional/professional codes and regulations.

Non-Fulton product information is for reference purposes only. No Fulton document should substitute for full review of documentation available from the component manufacturer.

 **WARNING**

All information in this manual is for reference and guidance purposes, and does not substitute for required professional training, conduct, and strict adherence to applicable jurisdictional/professional codes and regulations.

Non-Fulton product information is for reference purposes only. No Fulton document should substitute for full review of documentation available from the component manufacturer.

(primary) pump is enabled in a primary secondary piping system. When the boiler vessel water temperature falls below a configured temperature, the boiler (primary) pump will be enabled until the set temperature has been reached.

Stage 2 enables the burner if the boiler vessel water temperature falls below a configured temperature. The burner is held at low fire until the set temperature has been reached.

► *NOTE: If a high temperature condition occurs exceeding the high limit setting the boiler will require a manual reset.*

The Soft Limit acts to prevent nuisance manual reset high limit trips. If the boiler outlet temperature exceeds the soft limit, the burner will be driven to low fire until the outlet temperature is reduced to the value assigned in the Soft Limit Reset.

Cold Start allows the boiler to slowly reach temperature when receiving a demand at a cold water condition as configured. When enabled, this will take priority over the PID until the configured time or the configured boiler water temperature is reached.

► ANTI-CYCLE

This function is an override of burner demand, and not the PID while the burner is in operation. When enabled, the timer begins a count-down when the heat demand ends, and the burner will not be re-enabled until the anti-cycle timer expires.

■ Temperature

The boiler or multiple boiler system will maintain supply water temperature based on a setpoint temperature. This setpoint can come from a variety of sources, including by calculation from an outdoor air temperature sensor, a remote signal from the Building Management System (BMS), or from a static manually entered setpoint.

► SETPOINT

The Setpoint Source allows for the selection between the various setpoint sources available.

When in Outdoor Reset mode, the control will automatically calculate the hydronic loop setpoint based on the settings configured on the **Outdoor Reset** screen.

BMS Analog will monitor the 4-20mA contact for a remote setpoint signal. Enter the linearization settings to properly scale the signal to the desired temperature setpoints.

When in Modbus mode, the control will maintain setpoint based on the Modbus RTU write point. Protocol conversion gateways are available for alternate communication protocols including BACnet and LonWorks.

Local (Fixed) is used for static setpoints.

▶ OUTDOOR RESET

Separately entries are available for Occupied and Unoccupied modes.

The hydronic loop temperature setpoint will be calculated based on configured outdoor air and setpoint high and low temperature values. When the outdoor air temperature reaches a warm weather shutdown Outdoor Air Cutoff temperature, the boilers will be disabled until outdoor air temperature has decreased by the value assigned in the Cutoff Reset.

▶ SCHEDULING

The Scheduling system allows for the operator to configure when the normal (occupied) setpoint will be maintained. When outdoor reset is enabled, the normal setpoint curve will establish setpoint during these time frames with the setback (unoccupied) setpoint curve establishing setpoint for all other times.

■ Configuration

Functions are used during initial commissioning, troubleshooting and other tasks.

▶ SYSTEM CONFIGURATION

The System Configuration screen is used for saving (backup) and loading of program settings. The backup battery status is shown in the bottom right of the screen. Loss of power without an operational battery will result in lost program settings.

▶ SENSORS

An overview of boiler and auxiliary sensor status is available on this screen. Sensor offset values may be configured for calibration purposes.

▶ USER CONFIGURATION

An administrator password can be assigned to the control to prevent unauthorized access. The selected screens will require entry of the administrator password prior to access. The password may be up to 10 characters in length.



WARNING

All information in this manual is for reference and guidance purposes, and does not substitute for required professional training, conduct, and strict adherence to applicable jurisdictional/professional codes and regulations.

Non-Fulton product information is for reference purposes only. No Fulton document should substitute for full review of documentation available from the component manufacturer.

 **WARNING**

All information in this manual is for reference and guidance purposes, and does not substitute for required professional training, conduct, and strict adherence to applicable jurisdictional/professional codes and regulations.

Testing Safety Devices

■ Perform Test of Limit Controls

1. Reduce the high temperature limit to a lower setting and start the boiler. Allow water temperature to rise until the boiler locks out.
2. Allow the boiler to cool and acknowledge the alarm. Reset the high limit device, this condition requires a manual reset.
3. Set the high temperature limit to 200°F or a value at least 10-20°F above setpoint.

■ Perform Test of Low Gas Pressure Switch

1. With the boiler running, turn up the low gas pressure switch setting until a lock out occurs.
2. Acknowledge the alarm, return to the factory recommended setting and reset the switch.

■ Perform Test of High Gas Pressure Switch

1. With the boiler running, turn down the high gas pressure switch setting until a lock out occurs.
2. Acknowledge the alarm, return to the factory recommended setting and reset the switch.

■ Perform Test of Low Water Cut Off

1. From the Alarm History screen, tap the "Test Low Water" button. Observe the light switching off on the Low Water Cut Off Relay.
2. Acknowledge the alarm to reset the Low Water Cut Off relay. This condition requires a manual reset.

■ Perform Test of Manifold Air Switch

1. Increase the air switch setting to the maximum value and attempt to run the boiler. A lock out should occur during pre-purge.
2. Acknowledge the alarm, return to the factory recommended setting and reset the switch.

INTRODUCTION

1

INSTALLATION

2

OPERATION

3

MAINTENANCE

4

SERVICE DOCUMENTS

5

WARNING

All information in this manual is for reference and guidance purposes, and does not substitute for required professional training, conduct, and strict adherence to applicable jurisdictional/professional codes and regulations.

Prior to any maintenance concerning electrical components of this equipment, ensure electrical supply to the equipment is disconnected. Label all wires prior to disconnection; wiring errors may cause improper and hazardous operation.

Follow all proper lockout/tagout procedures for service.

Before beginning any maintenance, ensure area is free of any combustible materials and other dangers.

*What to do if you smell gas:
Do not try to light the appliance.
Do not touch any electrical switch.
Do not use any phone in the building.
Leave building and contact gas supplier from neighbor's phone. If you cannot reach gas supplier, phone the fire department.*

After initial start-up by qualified personnel, linkage, control settings, and fuel pressures should not be readjusted.

CAUTION

All maintenance procedures should be completed by trained personnel. Appropriate training and instructions are available from the Fulton Service Department at (315) 298-5121 or your local Fulton Heating Solutions Representative.

In order to meet warranty conditions, ensure all appropriate maintenance activities are performed.

General

This boiler has been designed to provide years of trouble free performance. To ensure continued safety and efficiency of the boiler, please follow the maintenance and inspection directions outlined in this section of the manual.

Daily, Weekly and Monthly Maintenance and Inspection are considered good practice for any boiler, and are applicable to the full line of Endura boilers. It is also good practice for any boiler installation to perform a thorough review of the overall system on a regular basis, and after any maintenance procedures. Any potential issues should be noted and followed up on to ensure safety and reliability of all relevant equipment. System review items may include:

- Looking for discoloration of any painted equipment, boiler jacket panels, and/or insulation used in system piping.
- Carefully checking for gas leaks using a combustible gas detector during commissioning and regular inspections; a GASMate® 0119 or equivalent is recommended. This includes, but is not limited to: Gas delivery system, gas train fittings, pressure switches, gas valves, regulators, conduit connections to gas devices, and pre-mix delivery components.
- Looking for evidence of leaks including the air intake/exhaust systems, boilers, hydronic system piping, pumps, valves and other system components.
- Once boilers are running, making sure there are no flue gases around the boilers, or in the boiler room.

► *NOTE: Combustion analysis and adjustment schedule can vary based on boiler application and seasonal conditions. Biannual or quarterly adjustment may be optimal in some applications—for example, systems operating as both winter heat and summer reheat.*

Daily Inspection Schedule

Daily inspection must include the following:

1. Observe operating temperature and general conditions.
2. Make sure that the flow of combustion and ventilating air to the boiler is not obstructed.
3. Make sure the boiler area is free and clear of any combustible materials, including flammable vapors and liquids.

Weekly Inspection Schedule

Weekly maintenance must include the following:

1. Observe the conditions of the main flame. Correct fuel/air adjustment is essential for the efficient and reliable operation of this boiler. If an adjustment to the combustion is necessary, the flue gas composition should be checked with a carbon dioxide (CO₂) or oxygen (O₂) analyzer to set conditions.

Tool List

To complete routine preventative maintenance or repairs, certain tools and supplies will be required that are not provided with the boiler. The qualified service technician should be prepared with the following tools and supplies.

- Siemens AZL23.00A9 with Connector Cable
- Digital Multimeter (DMM) with True RMS
- 16GB or larger USB Flash Drive (FAT32 format only) with the current PURE Control™ Software
- Maintenance Checklist Form and Pen/Pencil
- Slack Tube® Manometer or Equivalent
- GAS-Mate® Combustible Gas Leak Detector or Equivalent
- Calibrated Flue Gas Analyzer
- Calibrated Calipers
- Calibrated Torque Wrench
- Calibrated Torque Screwdriver with T25 Drive
- Pipe Wrenches
- Crescent Adjustable Wrench
- Blade (Flat-Head), Phillips, and Torx Screwdriver Sets
- Close Quarters Angled Phillips Screwdriver
- Socket Wrench
- SAE Socket Set
- SAE Deep Socket Set
- Metric Socket Set
- Metric Deep Socket Set
- SAE Wrench Set
- Metric Wrench Set
- 9/16" Crowfoot Wrench
- Metric Allen/Hex Key Wrench or Socket Set
- Grade #00 Very Fine Steel Wool Pad
- Super O-Lube or Equivalent
- Permatex® Dielectric Grease or Equivalent
- Loctite® LB8150 Silver Grade Anti-Seize or Equivalent
- Loctite® C5-A Copper Anti-Seize or Equivalent
- Hercules® Megaloc® Thread Sealant or Equivalent
- Portable Shop Vacuum
- Compressed Air with Blow Gun Nozzle
- Appropriate Personal Protective Equipment (PPE)
- Lockout-Tagout (LOTO) Tags



WARNING

All information in this manual is for reference and guidance purposes, and does not substitute for required professional training, conduct, and strict adherence to applicable jurisdictional/professional codes and regulations.

Prior to any maintenance concerning electrical components of this equipment, ensure electrical supply to the equipment is disconnected. Label all wires prior to disconnection; wiring errors may cause improper and hazardous operation.

Follow all proper lockout/tagout procedures for service.

Before beginning any maintenance, ensure area is free of any combustible materials and other dangers.

*What to do if you smell gas:
Do not try to light the appliance.
Do not touch any electrical switch.
Do not use any phone in the building.
Leave building and contact gas supplier from neighbor's phone. If you cannot reach gas supplier, phone the fire department.*

After initial start-up by qualified personnel, linkage, control settings, and fuel pressures should not be readjusted.



CAUTION

All maintenance procedures should be completed by trained personnel. Appropriate training and instructions are available from the Fulton Service Department at (315) 298-5121 or your local Fulton Heating Solutions Representative.

In order to meet warranty conditions, ensure all appropriate maintenance activities are performed.

WARNING

Personnel performing burner assembly maintenance must wear appropriate respiratory protection. Failure to do so may result in the inhalation of refractory ceramic fibers.

CAUTION

All information in this manual is for reference and guidance purposes, and does not substitute for required professional training, conduct, and strict adherence to applicable jurisdictional/professional codes and regulations.

All maintenance procedures should be completed by trained personnel. Appropriate training and instructions are available from the Fulton Service Department at (315) 298-5121 or your local Fulton Heating Solutions Representative.

In order to meet warranty conditions, ensure all appropriate maintenance activities are performed.

Burner gaskets must not be reused. Gasket is designed for one-time use only.

Using nuts and washers not provided by Fulton can lead to flue gas leakage and cause damage to the studs.

Follow proper safety precautions when using a ladder.

Monthly Maintenance Schedule

Monthly maintenance must include the following:

1. Test high-limit control by reducing setting below the operating temperature; burner should shut off. After readjusting the setpoint, reset the control.
2. Test operating temperature control by reducing temperature setting as necessary to check burner operation.
3. Check flue gas temperature at outlet. If there is a temperature increase over previous readings, the probable cause is soot or water-scale build-up on the tubes. Consult Fulton Heating Solutions immediately if there is a concern.
4. Test low gas pressure switch and high gas pressure switch utilizing the procedure in **Operation** section of this manual.
5. Inspect the combustion air inlet filter. If dust, lint or debris has accumulated, replace the filter.

Procedure for Inspecting the Air Inlet Filter

Proceed as follows:

1. Remove the filter. The filter sits in the slot above the cabinet.
2. If debris has plugged or contaminated the filter, the filter must be replaced.
 - *NOTE: Operating the burner with the combustion air filter removed will void the burner warranty. A clean filter of the same Fulton part number (type, size and style) must be installed while the boiler is in operation.*
3. Return the filter to its original position in the slot.

Replacing or Updating the Boiler Control

Only update the software or firmware when directed by the factory. Lead/Lag integration requires the same firmware and software version on all units.

It is recommended to always update to the latest software when commissioning new boilers.

Annual Maintenance Schedule

Annual maintenance must be performed prior to each heating season, and includes but is not limited to the following tasks, which must be done by a factory trained technician:

1. Prepare the Annual Preventative Maintenance Kit
 - EDR-750/1000 kit P/N 4-50-081000
 - EDR-1500/2000 kit P/N 4-50-082001
2. Inspect the fuel train, burner and control panel to be sure components are free of debris and are properly attached to the boiler.
3. Replace the combustion air filter with a new filter of the same Fulton part number (type, size and style).
4. Examine the venting system (air intake and exhaust piping).
 - Check all joints and pipe connections for tightness.
 - Check piping for corrosion or deterioration.
 - Check that the piping is clear of debris.
 - Check that the condensate drain system is functioning.
5. Inspect the hydronic heating system for other problems.
6. Leak test the gas valves.
7. Clean the low water cut-out probe on the water outlet pipe. This can be accessed via the top removable panel.
8. Remove and inspect burner. Clean as necessary. See **Removing and Cleaning Burner** section of this manual.
9. Replace the flame rod.
10. Replace the ignition electrode assembly.
11. Address any open factory Service Bulletins.
12. Update the PURE Control software to the latest version.
13. Check the cabinet for leaks that would allow unfiltered combustion air to enter the cabinet. Any leaks should be taped or caulked. Damaged gaskets must be replaced.
14. Test relief valve per manufacturer instructions by lifting the lever for 5 seconds and allowing the valve to snap shut. Please see the manufacturer's recommendations on the relief valve tag.
15. Perform combustion analysis and adjust if necessary. A low O₂ level recess or harmonic can indicate a need for burner service.



WARNING

All information in this manual is for reference and guidance purposes, and does not substitute for required professional training, conduct, and strict adherence to applicable jurisdictional/professional codes and regulations.

Never use open flame or other sources of ignition to check for gas leaks.

Ensure boiler is off and cooled, with proper lockout - tagout per local codes prior to service and maintenance.



CAUTION

Use caution when using any cleaning solutions. Refer to local regulations for proper cleaning solution disposal.

Do not allow dust or dirt to accumulate around the boiler.

WARNING

All information in this manual is for reference and guidance purposes, and does not substitute for required professional training, conduct, and strict adherence to applicable jurisdictional/professional codes and regulations.

Never use open flame or other sources of ignition to check for gas leaks.

Ensure boiler is off and cooled, with proper lockout - tagout per local codes prior to service and maintenance.

CAUTION

Use caution when using any cleaning solutions. Refer to local regulations for proper cleaning solution disposal.

Do not allow dust or dirt to accumulate around the boiler.

Removing and Cleaning the Flame Rod

This boiler uses an ionization electrode flame rod (2-20-082010) for proof of burner flame during light-off and normal run. An inspection of the flame rod is required as part of the annual maintenance.

Replace the flame rod immediately if any of the following are observed:

- The electrode geometry is warped
- Severe corrosion is present on the electrode
- The porcelain or insulator area of the flame rod is cracked, chipped, or damaged.
- The spade terminal is corroded

Dust, carbon build up, or minor rust on the electrode surface can reduce the reliability of the flame rod. Clean the electrode using a grade #00 very fine steel wool pad.

Reinstall the flame rod in the combustion chamber. Verify the electrode is no more than 1/8" (3 mm) and a minimum of 1/16" (1.5 mm) from the surface of the burner head. Sight clearance to the burner through the ignition hole.

Removing and Cleaning Burner Assembly

Disassemble, inspect, and clean as follows:

1. Remove power and turn off gas supply. Allow the boiler to cool.
2. With the door open, place a ladder in front of the unit.
 - *NOTE: The top of the electrical panel is not a step; it should not be used to support a person's weight.*
3. Remove wires from ignition assembly.
4. Remove ignition assembly.
5. Remove the flame rod.
6. Remove the (4) bolts between the fan transition and the premix elbow. Do not removed the fan transition from the blower discharge.
7. Remove the (8) nuts and washers on burner flange.
 - *NOTE: Due to unique hardware specifications, alternate hardware must not be substituted. If hardware is lost or damaged, contact your Fulton representative for replacement.*

8. Remove premix elbow.
9. Remove burner flange top gasket.
10. Remove burner by pulling up, making sure not to scrape the sides of the burner. Place burner aside, flange side down.

► *NOTE: Do not use liquids or brushes when cleaning the burner.*

11. Vacuum any visible debris inside the burner. Compressed air may also be used, in moderation, to clean the pores of the woven material. Use the following guidelines:
 - Dislodge any particulate matter from the burner surface matrix, keeping the air nozzle about 2" from the burner's surface and blowing straight down the surface. Gently move the nozzle back and forth length-wise above the surface. Avoid blowing air tangentially across the surface as this may cause damage to burner surface. Allow particulate matter to fall from the burner through the air/gas inlet. A vacuum may be used at the air/gas inlet to assist in removing particulate matter.
12. If any burner damage is detected, contact your Fulton Representative.

Reassemble in reverse order as follows:

1. Replace the fan discharge transition to premix elbow O-ring and apply Super O-Lube (P/N [2-12-000661](#)) to the O-ring.
 - EDR-750/1000 O-ring P/N [2-12-000236](#)
 - EDR-1500/2000 O-ring P/N [2-12-000235](#)
2. Replace upper and lower burner flange gaskets.
 - EDR-750/1000 burner gaskets P/N [2-12-0001270](#) (2 each)
 - EDR-1500/2000 burner gaskets P/N [2-12-0001260](#) (2 each)
3. Apply belleville washers so that they crown in middle; do not substitute nuts or washers with unapproved hardware.
4. Apply anti-seize to burner flange studs and torque to 23 ft-lbs. A torque adaptor will be required and should be used at 90° from the wrench handle.
5. Torque blower discharge to premix elbow nuts to 19 ft-lbs.
6. Reinstall ignitor or new ignitor. See **Verification of Ignition Gap** for instructions.
7. Apply CA-5 copper anti-seize to the flame rod hardware threads and install at no more than 1/8" (3.2 mm) and no less than 1/16" (1.6 mm) from the burner.
8. Ensure door and all latches are closed when complete.



WARNING

All information in this manual is for reference and guidance purposes, and does not substitute for required professional training, conduct, and strict adherence to applicable jurisdictional/professional codes and regulations.

Never use open flame or other sources of ignition to check for gas leaks.

Ensure boiler is off and cooled, with proper lockout - tagout per local codes prior to service and maintenance.



CAUTION

Use caution when using any cleaning solutions. Refer to local regulations for proper cleaning solution disposal.

Do not allow dust or dirt to accumulate around the boiler.

⚠ WARNING

All information in this manual is for reference and guidance purposes, and does not substitute for required professional training, conduct, and strict adherence to applicable jurisdictional/professional codes and regulations.

Never use open flame or other sources of ignition to check for gas leaks.

Ensure boiler is off and cooled, with proper lockout - tagout per local codes prior to service and maintenance.

⚠ CAUTION

Use caution when using any cleaning solutions. Refer to local regulations for proper cleaning solution disposal.

Do not allow dust or dirt to accumulate around the boiler.

Verification of Ignition Gap

This boiler uses a direct spark ignition electrode assembly (ignitor). Replacement of the ignitor is required as part of the annual maintenance. Inspection and adjustment of the ignitor is recommended as routine maintenance.

1. Remove ignition electrode assembly (ignitor). Visually check that the insulators are clean.
2. Replace with a new ignitor when performing annual maintenance.
 - EDR-750/1000 ignitor P/N [2-20-000135](#)
 - EDR-1500/2000 ignitor P/N [2-20-072000](#)
3. For re-installation or installation of a new ignitor, verify with calibrated calipers that there is a gap between electrodes greater than 0.100" (2.54 mm) and less than 0.125" (3.175 mm). See Figure 28.

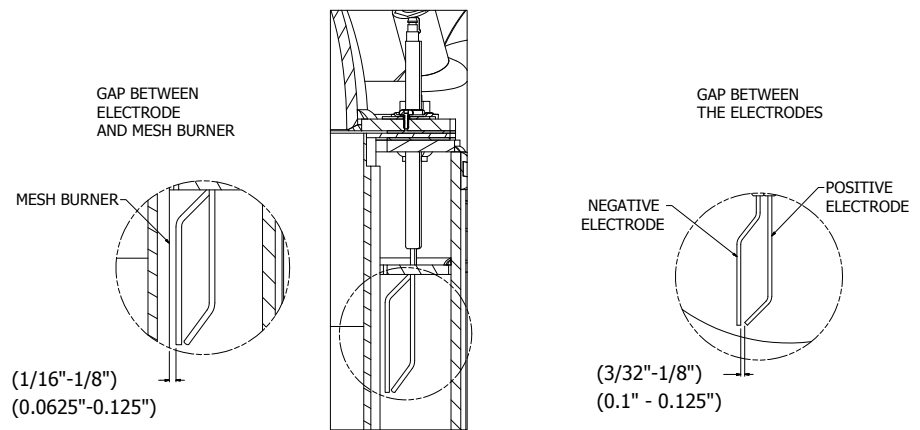

FIGURE 28 - IGNITOR GAP TOLERANCES

4. Install the ignitor on the burner flange: Apply anti-seize compound to ignitor screws and tighten in place using a torque-rated screwdriver to 8 inch-pounds. Use only a new gasket assembly, Fulton P/N [2-12-001261](#).
5. Remove the sight glass, flame scanner, and heat block. Position a light to shine into the combustion chamber through the sight glass as required.
6. Verify the burner head to ignitor gap with the use of a borescope. For borescopes equipped with a mirror, insert the end straight down into the combustion chamber at least 6" (152 mm) to view the ignitor from the side and bottom. For borescopes not equipped with a mirror, bend and angle the camera to obtain a necessary view.

7. Visually verify the ignition position relative to the burner head.
 - The negative electrode must not be touching or resting on the burner head.
 - The two electrodes must not be touching. See Figure 76.
 - The burner to ignition gap tolerance is 0.0625" (1.588 mm) to 0.125" (3.175 mm), it should appear visually similar to the electrode gap. See Figure 76.
8. Remove the borescope and reinstall the heat block, flame scanner, and sight glass. Apply new thread sealant to all applicable connections.

After All Repairs and Maintenance

1. Perform all Safety Checks as described in the **Operation** section.
 2. Fire the boiler and perform a full combustion verification. Make adjustments as necessary.
 3. Complete the "Installation and Operation Report" or "Annual Maintenance Checklist" and retain in the boiler's service history records.
- *NOTE: Accurate and complete combustion and maintenance records detailing compliance with the Installation, Operation and Maintenance manual must be produced for warranty consideration.*

WARNING

All information in this manual is for reference and guidance purposes, and does not substitute for required professional training, conduct, and strict adherence to applicable jurisdictional/professional codes and regulations.

Never use open flame or other sources of ignition to check for gas leaks.

Ensure boiler is off and cooled, with proper lockout - tagout per local codes prior to service and maintenance.

CAUTION

Use caution when using any cleaning solutions. Refer to local regulations for proper cleaning solution disposal.

Do not allow dust or dirt to accumulate around the boiler.

Parts Diagrams

ITEM	PART NUMBER	DESCRIPTION	QTY
1	2-12-315004	1/8"ID x 1/4"OD ABRASION RESISTANT, FLEXIBLE NEOPRENE TUBING	1
2	2-20-00023	3" WATER LEVEL PROBE	1
3	2-22-000048	1/4" STAR WASHER	1
4	2-22-000389	10-32 X 25mm BOLT, 18.8 STAINLESS	2
5	2-30-000205	IMMERSION WELL, COPPER, 1/2" SPUD, 3/8" X 3" MAX BULB, 1-1/2" INSULATION, WITH MOUNTING CLAMP	2
6	2-30-071039	7" X 7" X 1" METAL MESH WASHABLE SYNTHETIC AIR FILTER	1
7	2-30-315001	PSF 100A PRESSURE SENSOR 2" SETTING	1
8	2-35-000263	1/4" X 1/8" 150# BUSHING	1
9	2-35-315001	1/8" HOSE ID X 1/8" NPT BRASS BARBED FITTING	1
10	2-40-000251	OPERATING LIMIT AQUASTAT (100-240F)	1
11	2-40-000294	HIGH LIMIT AQUASTAT WITH MANUAL RESET (100-200F)	1
12	2-40-000976	TRANSFORMER 120V 50 / 60 Hz 15.6KVPK SECONDARY 28 MA	1
13	2-45-000423	FEMALE NYLON EXPANDED INSULATED CONNECTOR, 16-14 AWG	3
14	2-45-000431	EYELET WIRE RING TERMINAL, 16-14 AWG NYLON EXPANDED INSULATION (14RB-14)	3
15	2-45-000513	MOLEX RECEPTACLE- 2 CIRCUITS - DUAL ROW MINI FIT	3
16	2-50-315110	EDR, EDR+ AQUASTAT BRACKET	1
17	2-50-315301	STAINLESS STEEL PT100 SENSOR, HEX14, 1/4"NPT, 9.5 X 45MM	1
18	2-50-315302	BRASS PT100 SENSOR, HEX14, 1/4"NPT, 9.5 X 45MM	2
19	5-11-000018	18" LONG HIGH VOLTAGE IGNITION CABLE WITH 1/4" FEMALE CONNECTIONS	1

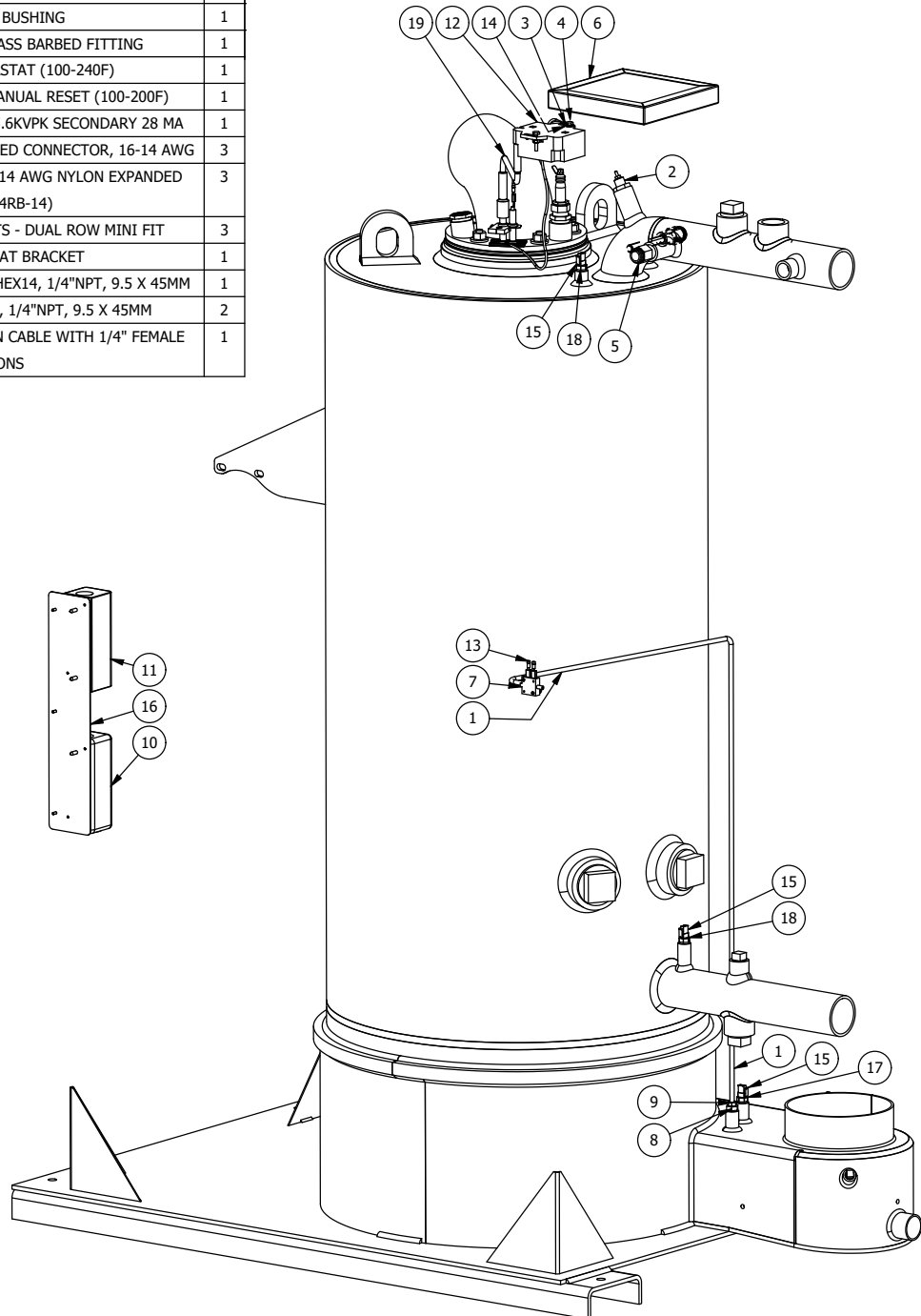

FIGURE 29 - INSTRUMENTATION AND DEVICES (EDR-750/1000)

ITEM	PART NUMBER	DESCRIPTION	QTY	ITEM	PART NUMBER	DESCRIPTION	QTY
1	2-12-315004	1/4" X 1/8" ID FLEXIBLE NEOPRENE TUBING	1	9	2-40-000294	HIGH LIMIT AQUASTAT WITH MANUAL RESET (100-200F)	1
2	2-20-000023	3" WATER LEVEL PROBE	1	10	2-40-000976	TRANSFORMER 120V 50 / 60 Hz 15.6KVPK SECONDARY 28 MA	1
3	2-22-000048	1/4" STAR WASHER	1	11	2-45-000513	MOLEX RECEPTACLE- 2 CIRCUITS - DUAL ROW MINI FIT	3
4	2-22-000389	10-32 X 25mm BOLT, 18.8 STAINLESS	2	12	2-45-315027	DOUBLE-CRIMP FEMALE NYLON EXPANDED FULLY INSULATED CONNECTOR, 16-14 AWG	2
5	2-30-000205	IMMERSION WELL, COPPER, 1/2" SPUD, 3/8" X 3" MAX BULB, 1-1/2" INSULATION, WITH MOUNTING CLAMP	2	13	2-50-315110	EDR, EDR+ AQUASTAT BRACKET	1
6	2-30-315001	PSF 100A PRESSURE SENSOR 2" SETTING	1	14	2-50-315301	STAINLESS STEEL PT100 SENSOR, HEX14, 1/4"NPT, 9.5 X 45MM	1
7	2-35-315005	1/8" HOSE ID X 1/4" NPT SS BARBED FITTING	1	15	2-50-315302	BRASS PT100 SENSOR, HEX14, 1/4"NPT, 9.5 X 45MM	2
8	2-40-000251	OPERATING LIMIT AQUASTAT (100-240F)	1	16	5-11-000018	18" LONG HIGH VOLTAGE IGNITION CABLE WITH 1/4" FEMALE CONNECTORS	1

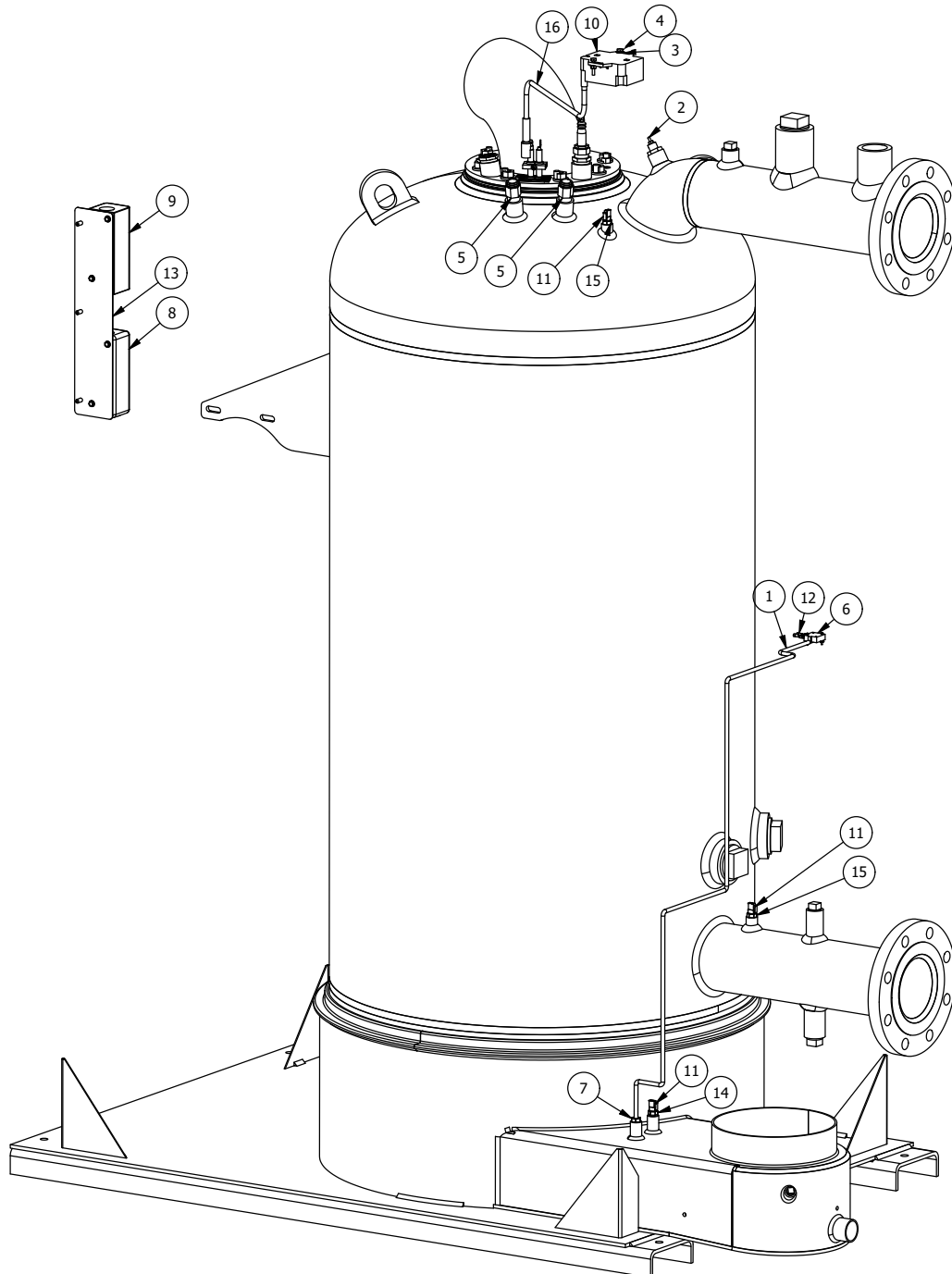

FIGURE 30 - INSTRUMENTATION AND DEVICES (EDR-1500/2000)

ITEM	PART NUMBER	DESCRIPTION	QTY	U.O.M.	ITEM	PART NUMBER	DESCRIPTION	QTY	U.O.M.
1	2-30-000002	1" N.P.T. GAS VALVE VGG10.254U	1	EA.	19	2-35-001634	1/4" N.P.T. X 3/8" COMPRESSION STAINLESS STEEL FITTING	2	EA.
2	2-30-000113	1" UL GAS BALL VALVE W/ DUAL SIDE TAPS	2	EA.	20	2-40-000387	LOW GAS PRESSURE SWITCH W/ MANUAL RESET 1"-20" WC	1	EA.
3	2-30-000282	1/4" FNPT X 1/4" MNPT BALL VALVE CSA	1	EA.	21	2-40-000390	HIGH GAS PRESSURE SWITCH W/ MANUAL RESET 2"-20" WC	1	EA.
4	2-35-000129	1" X 2" - NPT SCH 40 NIPPLE	3	EA.	22	2-40-000884	AIR/GAS RATIO VALVE 120V	1	EA.
5	2-35-000130	1" X 3" - NPT SCH 40 NIPPLE	2	EA.	23	2-40-001089	1" MED PORT ALUMINUM BUTTERFLY VALVE	1	EA.
6	2-35-000223	1" THREADED TEE	1	EA.	24	2-45-000048	TWO SCREW STRAIN RELIEF T&B	4	EA.
7	2-35-000269	1/4" THREADED ELBOW	3	EA.	25	5-10-081532	ENDURA 750K / 1000K PURE GAS TRAIN SENSE LINE	1	EA.
8	2-35-000271	1" THREADED ELBOW	3	EA.					
9	2-35-000284	1" 150# CARBON STEEL UNION	2	EA.					
10	2-35-000286	1" 150# THREADED CAP	1	EA.					
11	2-35-000371	1/4" X 2" - NPT SCH 80 NIPPLE	4	EA.					
12	2-35-000728	1" X 5" - NPT SCH 40 NIPPLE	2	EA.					
13	2-35-000944	1/4" X 5" - NPT SCH 80 NIPPLE (SA-53 - ERW)	1	EA.					
14	2-35-001021	1" X 20" - NPT SCH 40 NIPPLE	1	EA.					
15	2-35-001230	1/4" BRASS SQUARE HEAD PLUG	1	EA.					
16	2-35-001425	1" X 2 1/2" - NPT SCH 40 NIPPLE	1	EA.					
17	2-35-001430	1" X 9" - NPT SCH 40 NIPPLE	1	EA.					
18	2-35-001555	1" X 12" - NPT SCH 40 NIPPLE	1	EA.					

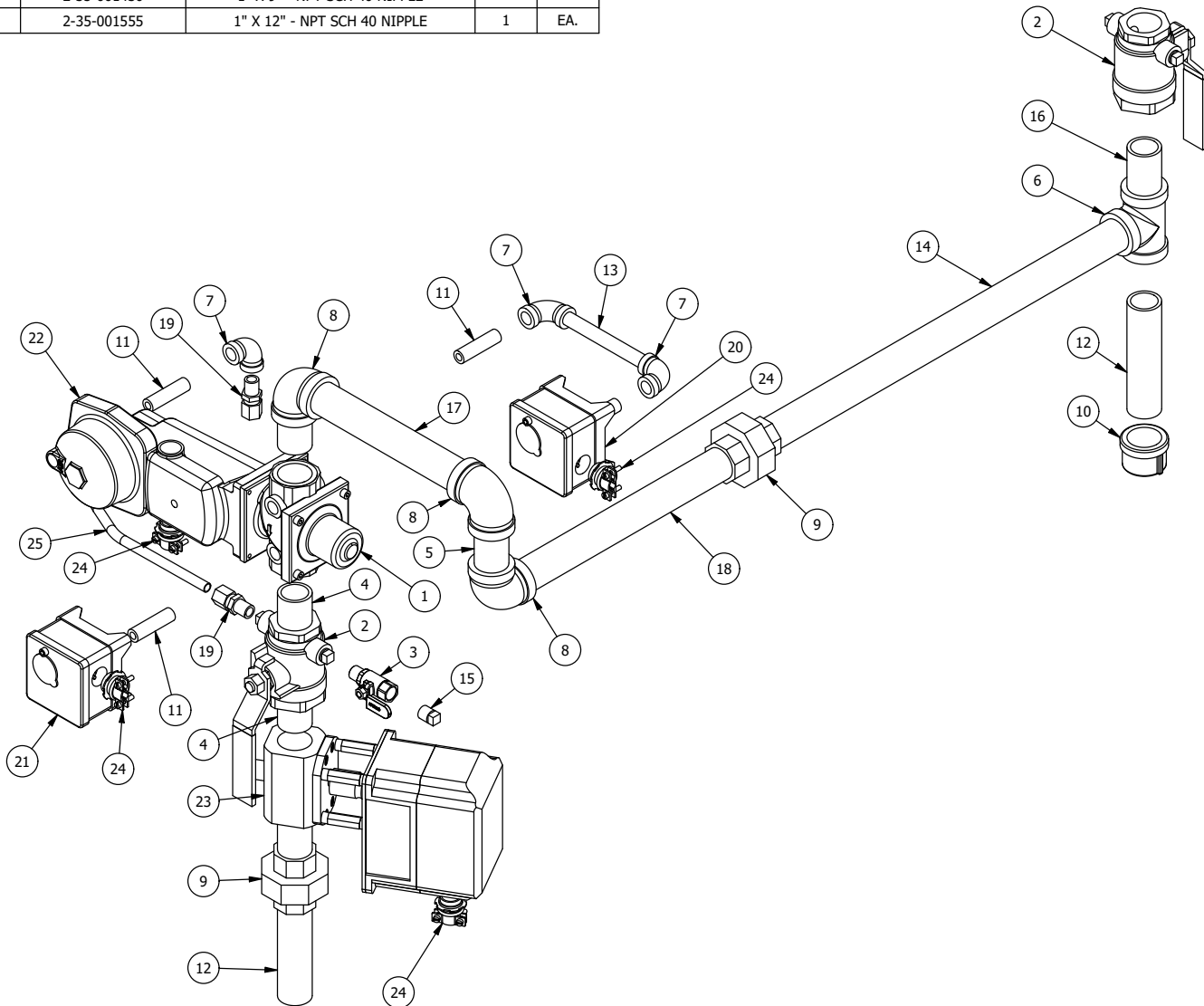

FIGURE 31 - GAS TRAIN (EDR-750/1000)

ITEM	PART NUMBER	DESCRIPTION	QTY	ITEM	PART NUMBER	DESCRIPTION	QTY
1	2-22-000215	#8 USS FLAT WASHER - ZINC PLATED	4	20	2-35-001230	1/4" BRASS SQUARE HEAD PLUG	1
2	2-22-000294	8-32 STOP NUT - NYLON INSERT - STEEL	4	21	2-35-001362	1 1/2" X 16" - NPT SCH 40 NIPPLE	1
3	2-22-315013	#8-32 X 1/2" SOCKET HEAD CAP SCREW	4	22	2-35-001364	1 1/2" X 22 1/2" - NPT SCH 40 NIPPLE	1
4	2-30-000003	1 1/2" N.P.T.GAS VALVE VGG10.404U	1	23	2-35-001440	1 1/2" X 2 1/2" - NPT SCH 40 NIPPLE	5
5	2-30-000115	1 1/2" UL GAS BALL VALVE W/ DUAL SIDE TAPS	1	24	2-35-001441	1 1/2" X 3 1/2" - NPT SCH 40 NIPPLE	1
6	2-30-000115	1 1/2" UL GAS BALL VALVE W/ DUAL SIDE TAPS	1	25	2-35-001443	1 1/2" X 5 1/2" - NPT SCH 40 NIPPLE	1
7	2-30-000282	1/4" FNPT X 1/4" MNPT BALL VALVE CSA	1	26	2-35-001634	1/4" N.P.T. X 3/8" COMPRESSION STAINLESS STEEL FITTING	2
8	2-35-000150	1 1/2" X 3" - NPT SCH 40 NIPPLE	1	27	2-40-000387	LOW GAS PRESSURE SWITCH W/ MANUAL RESET 1"-20" WC	1
9	2-35-000166	1 1/4" X 2 1/2" - NPT SCH 40 NIPPLE	1	28	2-40-000390	HIGH GAS PRESSURE SWITCH W/ MANUAL RESET 2"-20" WC	1
10	2-35-000178	1/4" 3000# FULL COUPLING	1	29	2-40-000884	AIR/GAS RATIO VALVE 120V	1
11	2-35-000225	1 1/2" THREADED TEE	1	30	2-40-002104	1 1/2" MEDIUM PORT BUTTERFLY VALVE	1
12	2-35-000269	1/4" THREADED ELBOW	5	31	2-45-000048	TWO SCREW STRAIN RELIEF T&B	4
13	2-35-000274	1 1/2" THREADED ELBOW	3	32	5-10-081531	EDR 1500, 2000 PURE GAS TRAIN SENSE LINE	1
14	2-35-000288	1 1/2" 150# THREADED CAP	1	33	5-10-081579	ENDURA GAS TRAIN LOW GAS PRESSURE SWITCH BRACE	1
15	2-35-000296	1 1/2" 150# CARBON STEEL UNION	2				
16	2-35-000371	1/4" X 2" - NPT SCH 80 NIPPLE	6				
17	2-35-000536	1/4" X 4" - NPT SCH 80 NIPPLE	2				
18	2-35-000804	1 1/2" X 5" - NPT SCH 40 NIPPLE	1				
19	2-35-001100	1 1/2" X 1 1/4" 150# REDUCING COUPLING	1				

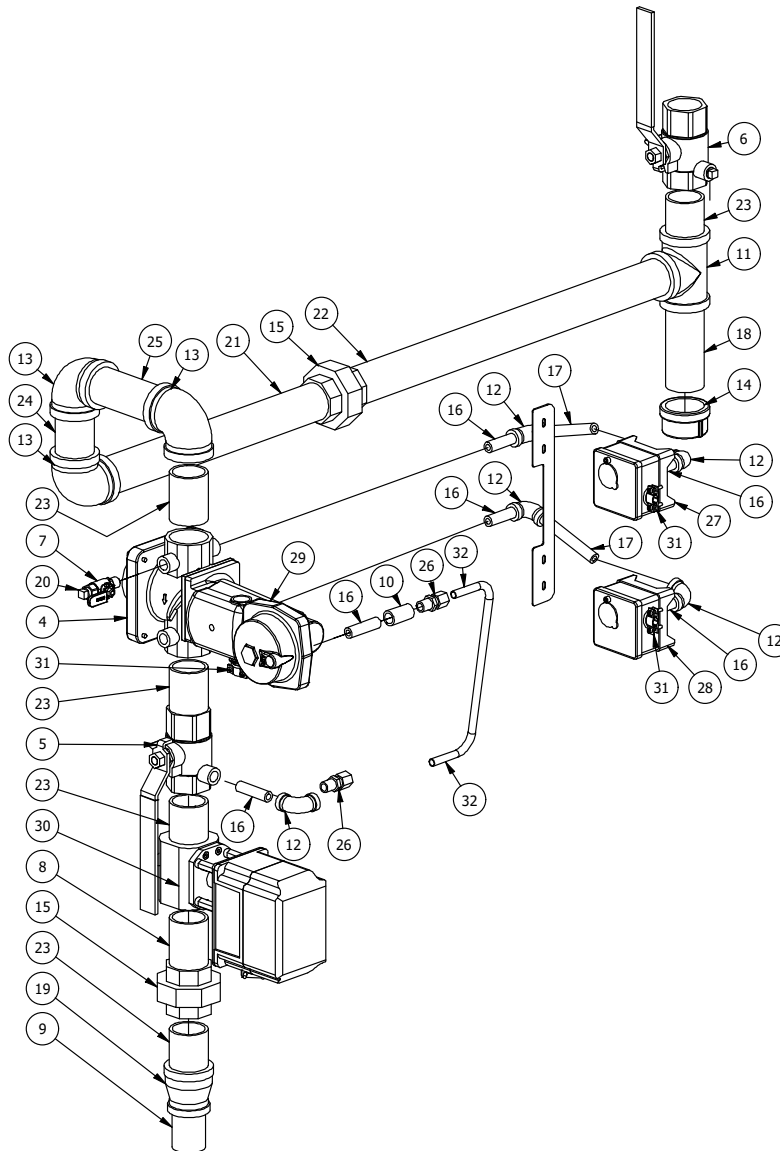

FIGURE 32 - GAS TRAIN (EDR-1500/2000)

ITEM	PART NUMBER	DESCRIPTION	QTY	ITEM	PART NUMBER	DESCRIPTION	QTY
1	2-40-000423	11 PIN RELAY BASE	2	17	2-45-000810	DIN RAIL END ANCHOR (35MM)	10
2	2-40-000474	LMV3 PLUG CONNECTION SET	1	18	2-45-000816	PUSH-IN TERMINAL BLOCK JUMPER - 2 (6MM)	1
3	2-40-000476	LMV36.520A1 120V SINGLE FUEL BURNER CONTROL	1	19	2-45-000817	PUSH-IN TERMINAL BLOCK JUMPER - 3 (6MM)	2
4	2-40-001421	FULTON HI/LO WATER RELAY	1	20	2-45-000818	PUSH-IN TERMINAL BLOCK JUMPER - 4 (6MM)	3
5	2-45-000371	1 POLE 30 AMP DEAD FRONT FINGERSAFE FUSE HOLDER	1	21	2-45-000830	SINGLE CIRCUIT, 35A TERMINAL BLOCK (22GA. - 10GA.)	53
6	2-45-000384	KLDR 8AMP 600 VAC TIME DELAY FUSE	1	22	2-45-000912	RS232-RS485 MODULE CVM(OCT)	1
7	2-45-000580	30 AMP FINGERSAFE FUSE BLOCK COVER	1	23	2-45-001095	AB 700 - TBJ20R JUMPER 20 POLE FOR 700 - HL BLOCKS	2
8	2-45-000583	30 AMP CLASS J SINGLE POLE FINGERSAFE FUSE HOLDER	1	24	2-45-001095	AB 700 - TBJ20R JUMPER 20 POLE FOR 700 - HL BLOCKS	1
9	2-45-000618	8 WAY NEUTRAL JUMPER	1	25	2-45-001095	AB 700 - TBJ20R JUMPER 20 POLE FOR 700 - HL BLOCKS	1
10	2-45-000803	SINGLE CIRCUIT TERMINAL BLOCK END CAP	4	26	2-45-001235	1 POLE SIGNAL RELAY 120VAC	4
11	2-45-000804	SINGLE CIRCUIT, 2 CONNECTION, 30A TERMINAL BLOCK (30GA. - 10GA.)	14	27	2-45-315004	IO SLIM	2
12	2-45-000805	SINGLE CIRCUIT, 2 CONNECTION GROUND TERMINAL BLOCK (30GA. - 10GA.)	13	28	2-45-315005	IO WIDE	1
13	2-45-000806	SINGLE CIRCUIT, 2 CONNECTION TERMINAL BLOCK END CAP	11	29	2-45-315011	1 POLE SIGNAL RELAY 24VDC	11
14	2-45-000807	DUAL CIRCUIT, 35A TERMINAL BLOCK (26GA. - 10GA.)	5	30	2-45-315121	IO SLIM	1
15	2-45-000808	DUAL CIRCUIT TERMINAL BLOCK END CAP	1	31	2-45-315124	EXP END UNIT	1
16	2-45-000809	SINGLE CIRCUIT, 65A TERMINAL BLOCK (18GA. - 6GA.)	2	32	2-45-315901	POWER SUPPLY 120VAC - 24VDC	1
				33	2-45-880400	CONTROL RELAY 24VDC	2
				34	5-10-081590	PURE ELECTRICAL BACK PANEL	1
				35	2-45-000517	750/1000 PURE 15 AMP CUBE FUSE TCF15	1
					2-45-000535	1500/2000 PURE 25 AMP CUBE FUSE TCF25	

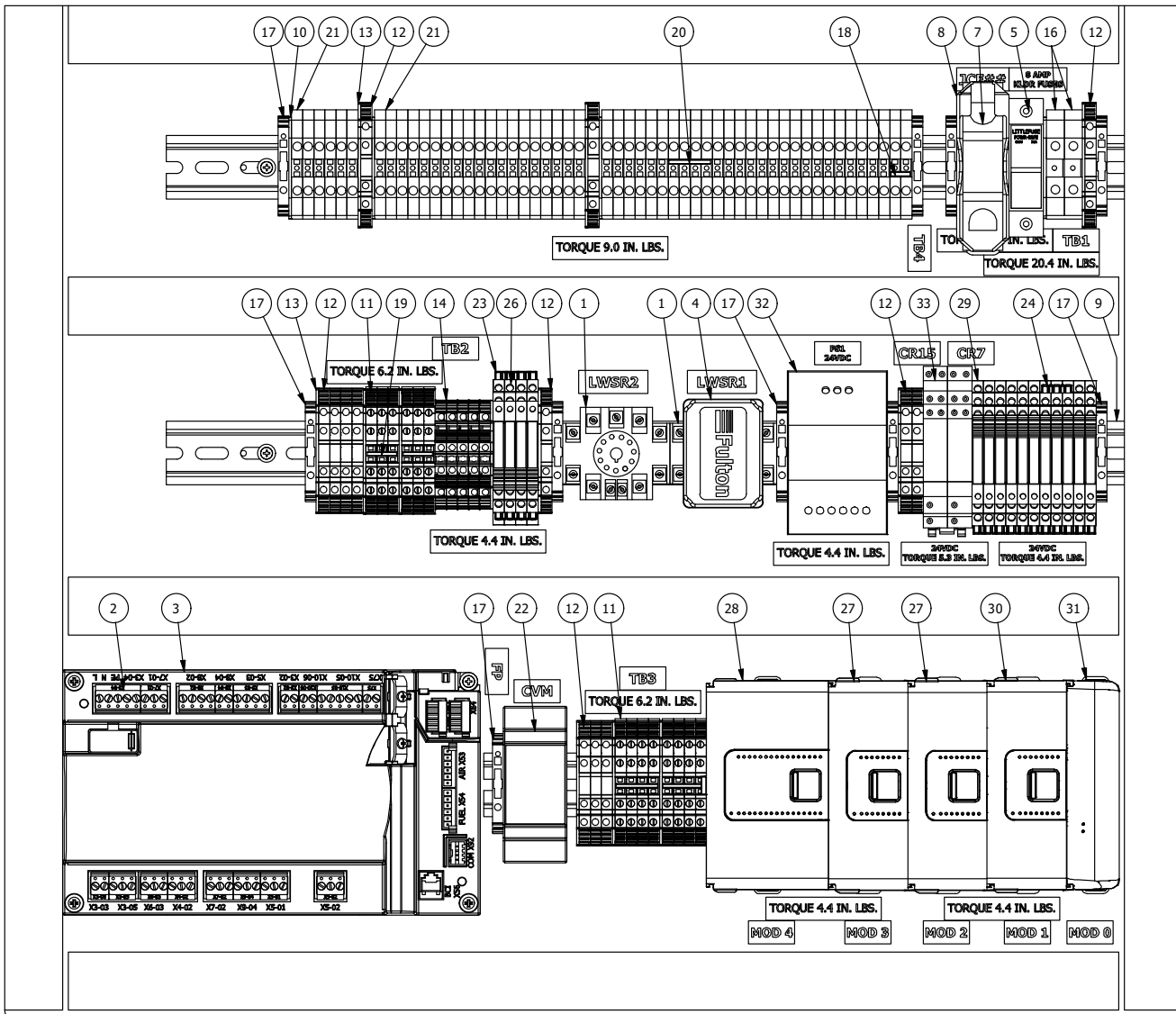

FIGURE 33 - ELECTRICAL CONTROLS (EDR-750 TO 2000)

ITEM	PART NUMBER	DESCRIPTION	QTY	U.O.M.	ITEM	PART NUMBER	DESCRIPTION	QTY	U.O.M.
1	2-10-000012	1/4" OD X .17 ID BLACK NYLON TUBING	1	FT.	26	2-22-420023	M5 X 0.8MM X 20MM LG. CLASS 12.9 SOCKET HEAD CAP SCREW	4	EA.
2	2-12-000012	3/4" NPT SIGHT OBSERVATION PORT	1	EA.					
3	2-12-000236	4 3/4" X 1/8" O-RING, VITON FLUOROELASTOMER	1	EA.	27	2-30-001266	PRESSURE SWITCH	1	EA.
4	2-12-001261	DIRECT SPARK IGNITION GASKET	1	EA.	28	2-30-071000	110mm ID X 3mm DIAMETER O-RING, NBR70	1	EA.
5	2-12-001270	ENDURA 1000K BURNER GASKET	2	EA.	29	2-30-081000	8.9 120VAC SINGLE PHASE PWM BLOWER WITH CLOSED LOOP RPM CONTROL	1	EA.
6	2-20-082010	EDR PURE FLAME ROD ASSEMBLY	1	EA.					
7	2-22-000001	1/4-20 HEX NUT, GR. 5	4	EA.	30	2-35-000260	3/4" X 1/2" 150# BUSHING	1	EA.
8	2-22-000002	5/16-18 HEX NUT, GR. 5	6	EA.	31	2-35-000306	1/4" 3000# PLUG	1	EA.
9	2-22-000011	1/4-20 X 1 1/4" HHCS, SAE GR. 5 BOLT	4	EA.	32	2-35-001368	1/4" NPT X 1/4" OD TUBE PUSH-TO-CONNECT TEE	1	EA.
10	2-22-000039	1/4" USS FLAT WASHER	8	EA.	33	2-35-001378	1/4" PUSH-TO-CONNECT PLUG	1	EA.
11	2-22-000040	5/16" USS FLAT WASHER	18	EA.	34	2-35-315001	1/8" HOSE ID X 1/8" NPT BRASS BARBED FITTING	1	EA.
12	2-22-000040	5/16" USS FLAT WASHER	6	EA.	35	2-40-071000	ENDURA 750K / 1000K MESH BURNER	1	EA.
13	2-22-000045	1/4" MEDIUM LOCK WASHER	4	EA.	36	2-40-081000	SIEMENS PBA	1	EA.
14	2-22-000046	5/16" MEDIUM LOCK WASHER	6	EA.	37	2-45-000061	FORK WIRE TERMINAL, 18-14 GA., BLUE	3	EA.
15	2-22-000101	5/16-18 X 1" HHCS, SAE GR. 5 BOLT	4	EA.	38	2-45-000513	MOLEX RECEPTACLE- 2 CIRCUITS - DUAL ROW MINI FIT	1	EA.
16	2-22-000215	#8 USS FLAT WASHER - ZINC PLATED	2	EA.	39	2-45-001016	MOLEX 16 AWG FEMALE TERMINAL PIN	2	EA.
17	2-22-000294	8-32 STOP NUT - NYLON INSERT - STEEL	2	EA.	40	2-50-315301	STAINLESS STEEL PT100 SENSOR	1	EA.
18	2-22-000351	3/8" BELLEVILLE WASHER	6	EA.	41	5-10-081581	EDR PURE PRESSURE SWITCH MOUNT	1	EA.
19	2-22-000386	3/8-16 HEX NUT, GR.8	6	EA.	42	5-10-081586	ENDURA 750K / 1000K PURE PBA BRACKET (PBA SIDE)	1	EA.
20	2-22-000390	10-32 X 3/8" LONG S.S. TORX SCREW	2	EA.	43	5-10-081587	ENDURA 750K / 1000K PURE PBA BRACKET (PV SIDE)	1	EA.
21	2-22-000394	5/16-18 HEX NYLOC NUT, GR. 5	4	EA.	44	5-10-C71090	ENDURA 0750 / 1000K BLOWER TRANSITION	1	EA.
22	2-22-000428	M5 X 0.8 - HEX NYLOC NUT, CLASS 8	4	EA.	45	5-10-C72010	ENDURA, ALL SIZES DIRECT SPARK IGNITION PLATE	1	EA.
23	2-22-000467	5/16-18 X 1 1/4" HHCS, SAE GR. 5 BOLT	6	EA.	46	5-20-071003	ENDURA DIRECT SPARK IGNITION ASSEMBLY WITH ENDURA IGNITER BRIDGE	1	EA.
24	2-22-315013	#8-32 X 1/2" SOCKET HEAD CAP SCREW	2	EA.					
25	2-22-420002	M8-1.25 x 12mm CLASS 10.9 BUTTON HEAD CAP SCREW	6	EA.	47	5-30-C71000	ENDURA 750K / 1000K BURNER ELBOW ASSEMBLY	1	EA.

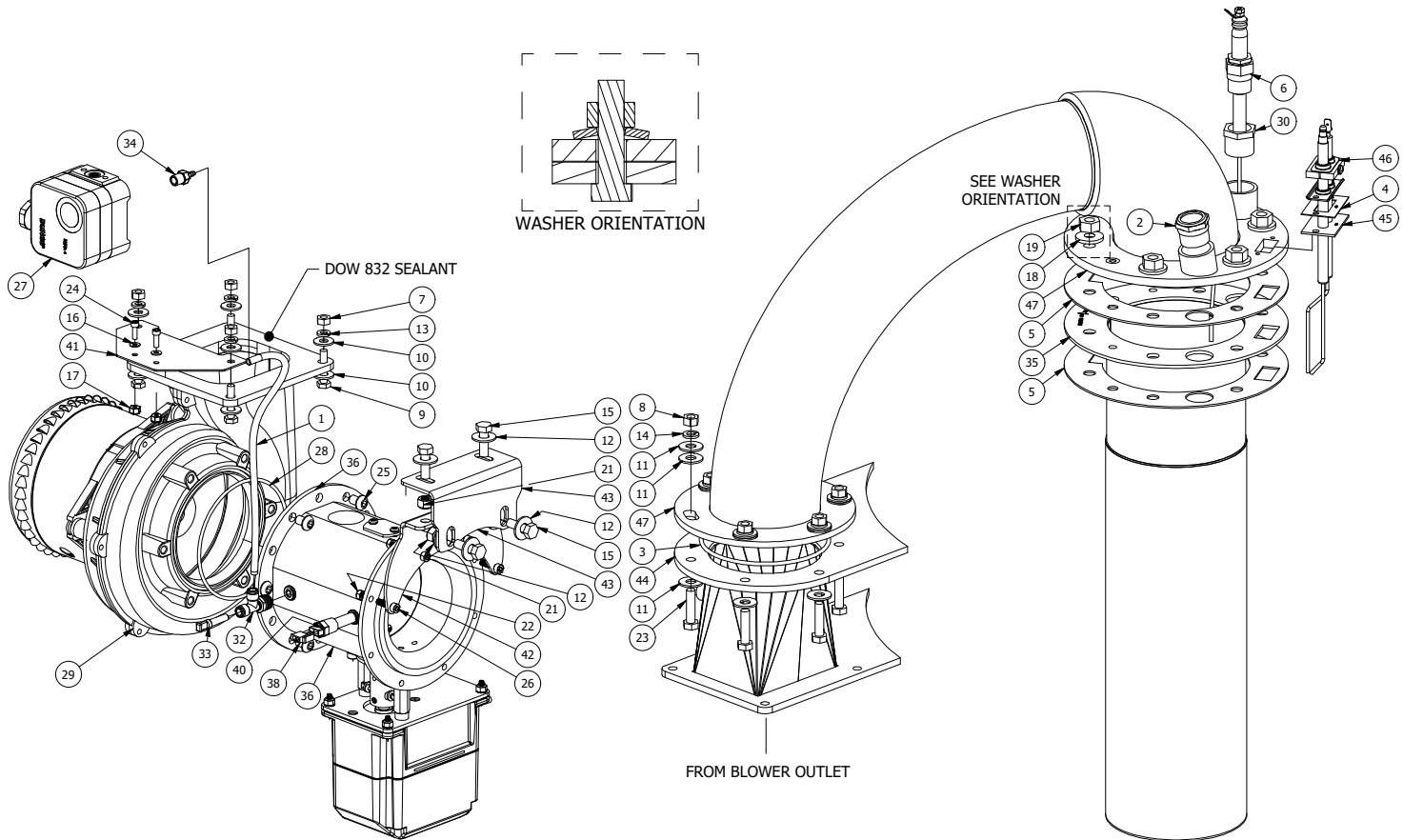

FIGURE 34 - BURNER AND PRE-MIX ASSEMBLY (EDR-750/1000)

ITEM	PART NUMBER	DESCRIPTION	QTY	ITEM	PART NUMBER	DESCRIPTION	QTY
1	2-10-00012	1/4" OD X .17 ID BLACK NYLON TUBING	1	31	2-22-420023	M5 X 0.8MM X 20MM LG. CLASS 12.9 SOCKET HEAD CAP SCREW	4
2	2-12-00012	3/4" NPT SIGHT OBSERVATION PORT	1				
3	2-12-000191	LOCTITE C5-A COPPER ANTI-SEIZE	1	32	2-23-000406	TAMPER PROOF TORQUE MARK, YELLOW	1
4	2-12-000235	5 3/4" OD X 1/8" O-RING, VITON FLUOROELASTOMER	1	33	2-30-001266	PRESSURE SWITCH	1
5	2-12-000661	O-RING LUBE	1	34	2-30-071646	12.3" 120 VAC SINGLE PHASE PWM BLOWER	1
6	2-12-001260	ENDURA 1500K / 2000K BURNER GASKET	2	35	2-30-072000	175mm ID X 4mm DIAMETER O-RING, NBR70	1
7	2-12-001261	DIRECT SPARK IGNITION GASKET	1	36	2-35-000260	3/4" X 1/2" 150# BUSHING	1
8	2-20-082010	EDR PURE FLAME ROD ASSEMBLY	1	37	2-35-000306	1/4" 3000# PLUG	1
9	2-22-000001	1/4-20 HEX NUT, GR. 5	6	38	2-35-001368	1/4" NPT X 1/4" OD TUBE PUSH-TO-CONNECT TEE	1
10	2-22-000002	5/16-18 HEX NUT, GR. 5	6	39	2-35-001371	1/8" NPT X 1/4" OD TUBE PUSH-TO-CONNECT ADAPTER	1
11	2-22-000011	1/4-20 X 1 1/4" HHCS, SAE GR. 5 BOLT	6	40	2-35-001378	1/4" PUSH-TO-CONNECT PLUG	1
12	2-22-000039	1/4" USS FLAT WASHER	12	41	2-40-000111	HEAT CONDUCTING COMPOUND	1
13	2-22-000040	5/16" USS FLAT WASHER	18	42	2-40-000976	TRANSFORMER 120V 50 / 60 Hz 15.6KVPK SECONDARY 28 MA	1
14	2-22-000040	5/16" USS FLAT WASHER	6				
15	2-22-000045	1/4" MEDIUM LOCK WASHER	6	43	2-40-071500	ENDURA MESH BURNER	1
16	2-22-000046	5/16" MEDIUM LOCK WASHER	6	44	2-40-072310	SIEMENS VA33-111A-D6220A9	1
17	2-22-000048	1/4" STAR WASHER	1	45	2-45-000061	FORK WIRE TERMINAL, 18-14 GA., BLUE	3
18	2-22-000101	5/16-18 X 1" HHCS, SAE GR. 5 BOLT	4	46	2-45-000513	MOLEX RECEPTACLE- 2 CIRCUITS - DUAL ROW MINI FIT	1
19	2-22-000215	#8 USS FLAT WASHER - ZINC PLATED	2	47	2-45-000916	TYCO FEMALE TERMINAL FOR BLOWER	1
20	2-22-000294	8-32 STOP NUT - NYLON INSERT - STEEL	2	48	2-45-000917	MOLEX 5 POLE PLUG FOR PWM BLOWER	1
21	2-22-000351	3/8" BELLEVILLE WASHER	8	49	2-45-001016	MOLEX 16 AWG FEMALE TERMINAL PIN	7
22	2-22-000386	3/8-16 HEX NUT, GR.8	8	50	2-45-001328	TYCO 12-10 AWG FEMALE TERMINAL PIN	3
23	2-22-000388	10-32 FLANGE STOP NUT - NYLON INSERT - STAINLESS	2	51	2-50-315301	STAINLESS STEEL PT100 SENSOR	1
24	2-22-000389	10-32 X 25mm BOLT, 18.8 STAINLESS	2	52	5-10-081576	EDR 1500, 2000 PURE PBA BRACKET (PBA SIDE)	1
25	2-22-000390	10-32 X 3/8" LONG S.S. TORX SCREW	2	53	5-10-081577	EDR 1500, 2000 PURE PBA BRACKET (PV SIDE)	1
26	2-22-000394	5/16-18 HEX NYLOC NUT, GR. 5	4	54	5-10-081581	EDR PURE PRESSURE SWITCH MOUNT	1
27	2-22-000428	M5 X 0.8 - HEX NYLOC NUT, CLASS 8	4	55	5-11-000018	18" LONG HIGH VOLTAGE IGNITION CABLE	1
28	2-22-000467	5/16-18 X 1 1/4" HHCS, SAE GR. 5 BOLT	6	56	5-20-072000	ENDURA EDR-1500 / EDR-2000 DIRECT SPARK IGNITION	1
29	2-22-315013	#8-32 X 1/2" SOCKET HEAD CAP SCREW	2	57	5-20-C71590	ENDURA 1500K / 2000K MACHINED BLOWER TRANSITION	1
30	2-22-420002	M8-1.25 x 12mm CLASS 10.9 BUTTON HEAD CAP SCREW	6	58	5-30-C71500	ENDURA 1500K / 2000K BURNER ELBOW ASSEMBLY	1

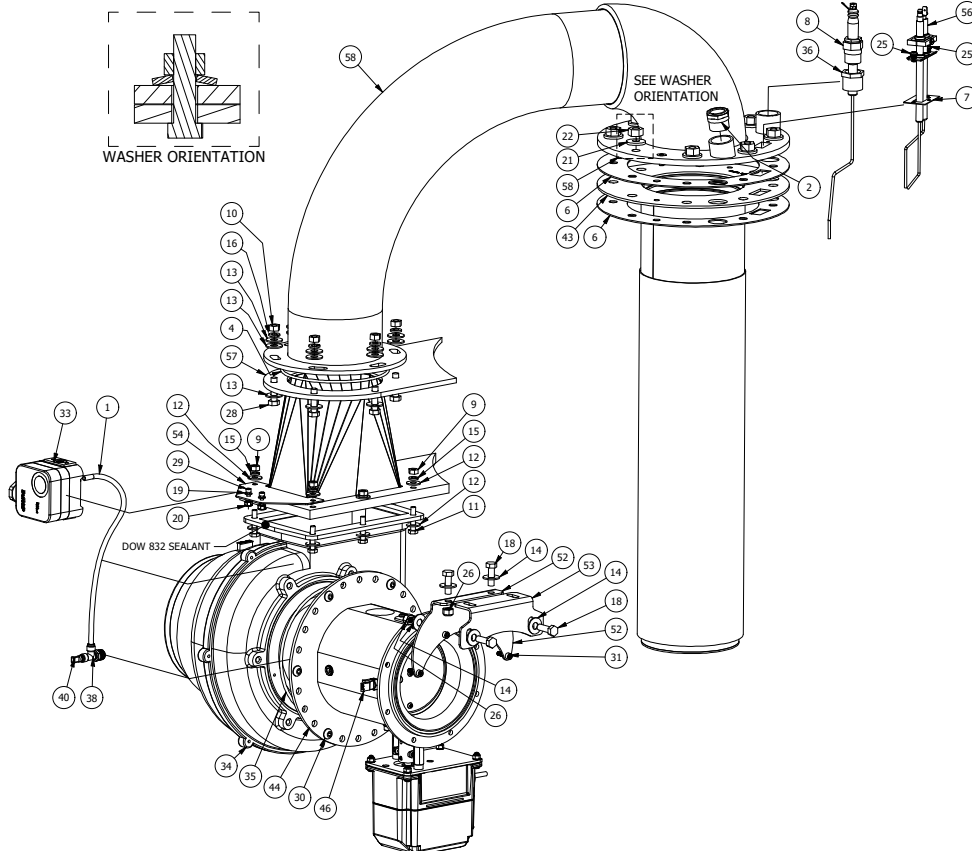

FIGURE 35 - BURNER AND PRE-MIX ASSEMBLY (EDR-1500/2000)

Troubleshooting

Use the following table as a guide to troubleshooting your boiler. For further support, record the boiler National Board #, Error Code, Diagnostic Code, and Phase of the alarm occurrence(s) and contact your local Fulton Representative.

PROBLEM	CAUSE	CHECK
No Power / Control Does not Illuminate	Power / Wiring / Connections	<p>Check fusing and replace as necessary.</p> <p>Cycle power to the boiler.</p> <p>Measure incoming voltage to boiler and verify it is in compliance with 120VAC requirements.</p> <p>Verify control power supply voltage.</p> <p>Verify all power plugs are fastened securely to control devices.</p> <p>Verify that the display mounting clips are not over tightened.</p> <p>Verify wiring between terminal blocks, power supplies and control devices.</p>
Nuisance Manual Reset High Temperature Limit Lockouts	Controller/Settings	<p>Verify the setting on the mechanical Manual Reset High Limit (MRHL) device, it must always be higher than the sum of the temperature setpoint plus off hysteresis value. The factory recommended setting is 200°F.</p> <p>Check the supply temperature setpoint setting parameter in the boiler control or Building Management System setpoint signal where applicable. The closer the setpoint setting is to the MRHL setting, the higher the likelihood of a lockout.</p>
	Installation	<p>Verify balancing valves (if used) have been properly commissioned.</p> <p>For modular boiler plants, ensure piping is configured reverse return where the first boiler in is the last boiler out. If the piping configuration is not reverse return, balancing valves should be installed and properly commissioned to ensure each boiler is receiving relatively equal water flow.</p> <p>Verify the boiler is receiving enough flow at the current heat demand for the given hydronic fluid type and desired delta-T. If calibrated flow meters are not available, flow rate can be approximated by calculation by observing the delta-T across the boiler heat exchanger at a given firing rate. See the Fulton "Calculating Flow Rate" Engineering Guide for more details.</p>
Blocked Exhaust Switch Lockouts	Installation	<p>Measure draft pressure at the flue gas outlet of the boiler during pre-purge, steady-state high fire, and post-purge conditions. The measurement must not exceed the maximum value listed in Table 4. If the stack pressure is exceeded, remove flue rain caps or velocity cones (if installed) and measure again.</p> <p>Verify any horizontal flue gas vent runs maintain minimum upward pitch.</p> <p>Inspect the horizontal venting sections for low spots. There must not be any low spots in the flue gas vent.</p> <p>Long flue gas vent runs may require stack drains to prevent condensate build up.</p> <p>Verify the boiler housekeeping pad height is a minimum of 4-inches (102 mm). Shorter pad heights may require a field installed condensate pump.</p> <p>Verify the condensate drain trap is installed at floor level, not boiler pad level.</p> <p>Verify the condensate drain lines maintain minimum downward pitch.</p> <p>Where an exhaust overdraft damper is installed:</p> <ul style="list-style-type: none"> · Verify the opening speed is sufficient to prevent a pressure spike in the exhaust vent when the boiler cycle starts or ends. · Verify the damper is not installed too close to the boiler flue outlet connection.
	Maintenance	<p>Inspect the flue gas vent for obstructions, such as rodents, debris, excessive RTV, improperly seated gaskets, or ice build up at the termination.</p> <p>Inspect the flue gas condensate drain lines, trap and neutralizer tank for obstructions.</p>

PROBLEM	CAUSE	CHECK
Boiler Excessively Cycling	Controller/Software	<p>Consult Fulton technical support to verify the latest software version is installed on the PURE Control.</p> <p>Verify boiler is configured for automatic operation.</p> <p>Verify temperature setpoint and on/off hysteresis settings are appropriate at each boiler. A tighter hysteresis band will increase cycling, relax (increase) this band to reduce cycling.</p> <p>Verify PID settings are appropriate for boiler application. Note that there are different PID settings for Local and for Lead/Lag operation. Verify these settings are correct and matching on each boiler installed.</p> <p>If a Building Automation is commanding temperature setpoint to the boiler(s), ensure that any setpoint changes are infrequent and slowly stepped in small increments/decrements. Rapid changes in temperature setpoint may cause boiler short cycling.</p>
Main Flame Failure	Maintenance	<p>Verify combustion parameters at all combustion points P1-P9. Adjust as necessary.</p> <p>Verify sufficient supply gas pressure within the requirements of the data plate at the rear of the boiler. Ensure gas pressure does not drop more than 15% between static (idle) and dynamic (high fire).</p> <p>Verify manifold gas pressure is within the specified requirements. Refer to the factory Test Fire Report included with the boiler. Note: Test Fire Report parameters are used as a reference point, site conditions will ultimately dictate what parameters are appropriate for safe and reliable operation.</p> <p>Inspect burner, clean according to maintenance instructions if dirty.</p> <p>Inspect combustion air filter. Replace if dirty.</p> <p>Verify flame rod wiring and operation; replace as needed.</p> <p>Using a manometer, measure the draft pressure at the boiler flue gas exhaust outlet connection during idle, trial for ignition, low fire and high fire. At all conditions the draft pressure must be within the limits specified in Table 4.</p> <p>Inspect the intake termination. Ensure it is not obstructed by ice, snow, or debris. Ensure the intake termination is not subjected to high wind.</p> <p>Inspect the flue gas exhaust termination. Ensure it is not obstructed by ice, snow, or debris. Ensure the flue gas exhaust termination is not subjected to high wind.</p> <p>Ensure Flue Gas Recirculation (FGR) is not occurring by visually witnessing the interaction of the exhaust and intake terminations during boiler main flame run. FGR will be evidenced by a vapor plume in the immediate vicinity of the intake termination. If occurring, this must be immediately corrected.</p> <p>Possible solutions for FGR include:</p> <ul style="list-style-type: none"> • Removing the exhaust termination rain cap (if installed) • Installing an exhaust termination velocity cone • Increasing the height of the exhaust termination • Increasing the horizontal separation of the intake to the exhaust termination <p>Verify the boiler room is at a neutral pressure relative to the outdoors.</p> <p>Verify no other mechanical equipment intake or exhaust is installed near the boiler combustion air intake, such as other boilers, water heaters, air handling equipment, cogen units and or cooling towers.</p>
CPU Error Displayed	Electrical/Wiring	<p>Verify all modules clipped into the back of display are fastened completely and securely.</p> <p>Replace CPU module and/or display.</p>

PROBLEM	CAUSE	CHECK
Temperature(s) Not Displaying Properly	Controller/Settings	Reset retained tags and reload user defaults. If an update was just performed, verify the correct software type for the boiler model and hardware was installed.
	Electrical/Wiring	If all temperatures are not displaying properly, verify all expansion modules are communicating and that Link and Power LEDs are illuminated green. Verify wiring to and from appropriate I/O modules. Verify temperature sensor operation. Replace sensor wiring on I/O module with a known working sensor to determine possibility of failed sensor or failed I/O module.
Errors During Program Update	Controller/Settings	Refer to the PURE Control User Manual for details regarding program updates. A 16GB or larger flash drive formatted to FAT32 only is required when performing a software update. If a "Version Mismatch: UniLogic/UniStream Firmware" screen is prompted while performing the program update, continue performing the update as outlined in Section 4 of the PURE Controls Addendum. If further issues are experienced, contact Fulton technical support
No SD Card Error	Controller/Settings	Install/Replace SD card with a capacity of 4GB or larger. Reference PURE Control User Manual for more information on SD card.
Burner Harmonic or Resonance	Maintenance	Inspect air filter, replace if dirty. Verify combustion at all operating points. Inspect burner, clean according to maintenance instructions if dirty.
Moisture collecting inside the combustion blower	Boiler / Maintenance	This is caused by moisture in the flue gas vent being pulled in the reverse flow direction during an off cycle. If a common manifold flue gas vent is installed, measure the pressure of the common manifold at each condition (idle, light off, low fire, high fire) using a slack-tube manometer. The common flue should always be maintained at a slight negative draft pressure. A positive pressure can push exhaust gases and moisture in the reverse direction. Inspect the boiler room space for ventilation fans. If present, confirm the fans are intake fans pushing air into the space. Exhaust type fans should never be used in a boiler room as they can draw a negative pressure in the space. Using a slack-tube manometer, verify the boiler room pressure is neutral relative to the outdoors. If the room is measured to be in a negative, this must be resolved. Where boilers are using room combustion air provided by openings communicating directly with the outdoors, verify the wall openings meet or exceed the net free area requirements detailed in Table 6. Be sure to take into account the blocking effects of grills and louvers.
Combustion blower does not start unless power cycled	Installation	For safety purposes, the blower will lockout if the maximum permitted ambient air temperature is exceeded. Ensure ambient air temperature does not exceed 120°F (48°C). Outdoor installations exposed to direct sun may require special considerations, such as a field installed cabinet cooling fan, to reduce the temperature inside the boiler cabinet.

PROBLEM	CAUSE	CHECK
Air Switch Lockouts	Controller/Settings	<p>Open the Alarm history, tap the row # of the air switch (AS) alarm, and tap "Info" to view detailed information. Document the detailed alarm information.</p> <p>Refer to the Siemens LMV3 Control section of this manual for instruction on using the AZL at the 400 parameter level. Run the boiler at each point while using a manometer to verify the manifold pressure meets Table 9 at all combustion points. If the manifold is not met at a point, first increase the manifold pressure, then correct the air/fuel ratio to obtain the proper O2%.</p> <p>If AS alarms are repeatedly occurring at low firing rates, ensure the minimum blower discharge pressure listed in Table 8 is met. For high wind areas, long or complex venting arrangements, consider increasing P1 blower discharge pressure then re-tune manifold and O2%.</p>
	Installation	<p>Verify combustion air intake (intake) and flue gas venting (vent) arrangements comply with this manual. Pay particular attention to termination styles, location(s) and separation.</p> <p>Verify intake and vent terminations are protected from wind effects. For sidewall terminations, verify they are covered with a tee or 90 degree elbow, terminations should not point directly sideways.</p> <p>Verify the boiler room pressure is neutral relative to the outdoors. The boiler room must not be under negative pressure.</p> <p>Where an exhaust damper is installed:</p> <ul style="list-style-type: none"> • Verify the opening speed is sufficient to prevent a pressure spike in the exhaust vent when the boiler cycle starts or ends. • Verify the damper is not installed too close to the boiler flue outlet connection. • If issues persist, lock the overdraft damper into the fully open position and observe if air switch alarms continue. If air switch alarms do not reoccur while the damper is locked into the full open position, contact the draft control provider for further troubleshooting instruction.
	Maintenance	<p>Verify the combustion blower is operating properly. If the blower requires a power cycle to start, refer to blower troubleshooting steps.</p> <p>Inspect intake and vent for obstructions. Use a manometer to verify the sum of both intake and vent pressures complies with Table 4.</p>
	Electrical/Wiring	<p>Verify the AS setting is -0.8 "W.C. for EDR-1500/2000 models, and -0.4 "W.C. for EDR-750/1000 models.</p> <p>Verify switch operation. Verify wiring to the switch and X3.02.1, X3.02.2 on the flame safeguard.</p>

PROBLEM	CAUSE	CHECK
Blocked Exhaust Alarm	Installation	<p>Verify minimum housekeeping pad height of 4" (102 mm) is met. If the minimum pad height is not met, a flue gas condensate pump may be required.</p> <p>Verify condensate drain lines are installed correctly:</p> <ul style="list-style-type: none"> • Maintains minimum downward pitch of 1 inch (25 mm) per 12 feet (3.65 m). • Common headers drop down to floor level, and are not installed at boiler drain or housekeeping pad level. <p>Verify the condensate drain trap is installed correctly:</p> <ul style="list-style-type: none"> • Placed on the floor, not the housekeeping pad, and not elevated off the floor. • With the correct direction and orientation. Fulton offers multiple styles of condensate drain traps, with different installation requirements. <p>Verify the flue gas vent is installed correctly:</p> <ul style="list-style-type: none"> • Vent maintains minimum pitch of ¼ inch (7 mm) rise per foot (305 mm) run and does not have any low spots. • A rain cap is not installed, rain caps are not recommended. • A vent condensate drain is installed directly after the boiler connection.
	Maintenance	<p>Verify flue gas vent drains are functional and not clogged.</p> <p>Verify the vent termination is not blocked by debris or ice.</p> <p>Verify vent sections are not blocked by excessive RTV or gaskets.</p> <p>Verify condensate drain lines are clear and not clogged.</p>

PAGE LEFT INTENTIONALLY BLANK

INTRODUCTION

1

INSTALLATION

2

OPERATION

3

MAINTENANCE

4

SERVICE DOCUMENTS

5

PAGE INTENTIONALLY LEFT BLANK



PRE-COMMISSIONING INSTALLATION CHECKLIST

NOTE:
TO BE COMPLETED BY INSTALLING CONTRACTOR.

DATE	
CONTACT NAME	
BOILER MODEL	

JOB SITE NAME	
PHONE NUMBER	
BOILER NB/SERIAL #(s)	

ELECTRICAL & COMMUNICATION:

Electrical wiring to the boiler terminated and tested?	<input type="checkbox"/> YES	<input type="checkbox"/> NO
Voltage matches the data plate on the rear of the boiler? (120V 60Hz 1Ø)	<input type="checkbox"/> YES	<input type="checkbox"/> NO
Control wiring for lead/lag is terminated and tested?	<input type="checkbox"/> YES	<input type="checkbox"/> NO <input type="checkbox"/> N/A
Building automation wiring is terminated and tested?	<input type="checkbox"/> YES	<input type="checkbox"/> NO <input type="checkbox"/> N/A

SYSTEM PIPING

All hydronic piping to the boiler is completed and leak tested?	<input type="checkbox"/> YES	<input type="checkbox"/> NO
All hydronic piping has been fully flushed? <i>Note: Chemical cleaning must bypass the boiler; clean water flush must have strainers at the boiler inlet</i>	<input type="checkbox"/> YES	<input type="checkbox"/> NO
Circulating pumps are wired, tested, and ready for operation?	<input type="checkbox"/> YES	<input type="checkbox"/> NO
Motorized boiler isolation valves are wired, tested, and fully operational?	<input type="checkbox"/> YES	<input type="checkbox"/> NO <input type="checkbox"/> N/A

FLUE GAS EXHAUST VENT AND COMBUSTION AIR INTAKE:

Flue vent meets material type and requirements detailed in the IOM?	<input type="checkbox"/> YES	<input type="checkbox"/> NO
Flue and combustion air terminations meet minimum separation requirements and are installed to prevent flue gas recirculation?	<input type="checkbox"/> YES	<input type="checkbox"/> NO
Condensate drain is completed and meets IOM installation requirements?	<input type="checkbox"/> YES	<input type="checkbox"/> NO
Combustion air louvers meet minimum SQFT detailed in IOM?	<input type="checkbox"/> YES	<input type="checkbox"/> NO <input type="checkbox"/> N/A
Mechanical draft controls are powered, tested, and fully operational?	<input type="checkbox"/> YES	<input type="checkbox"/> NO <input type="checkbox"/> N/A

FUEL PIPING

Supply gas piping and regulators are properly sized to ensure adequate gas supply under all operating conditions? (Idle, Light Off, High Fire, etc.)	YES	NO
Use a manometer to measure the gas pressure at the fuel train inlet:	_____	INCHES WC
Does the measured gas pressure meet the requirement listed on the data plate on the rear of the boiler?	YES	NO
Gas vents are individually run, properly upsized every 10 feet, and terminated to atmosphere if required by Authority Having Jurisdiction?	<input type="checkbox"/> YES	<input type="checkbox"/> NO <input type="checkbox"/> N/A
Gas regulators installed minimum 10 feet of pipe from the boilers?	<input type="checkbox"/> YES	<input type="checkbox"/> NO <input type="checkbox"/> N/A

SITE SIGN-OFF	
PRINT NAME	

DATE:	
TITLE:	

When complete, return a copy to your Fulton Representative and/or the service organization performing commissioning ("start-up") services.

PAGE INTENTIONALLY LEFT BLANK



**ENDURA (EDR)
INSTALLATION & OPERATION
“START-UP” REPORT**

NOTE:

TO BE COMPLETED BY A FACTORY AUTHORIZED TECHNICIAN HOLDING A VALID ENDURA (EDR) CERTIFICATE OF REGISTRATION. WARRANTY COVERAGE IS VALID ONLY IF THIS FORM IS SUCCESSFULLY COMPLETED AND RETURNED TO FULTON WITHIN TWELVE WEEKS OF START-UP.

DATE	
TECHNICIAN	
TECH. COMPANY	
TECH CERTIFICATE #	
BOILER MODEL	
NATIONAL BOARD #	

FULTON REP.	
CUSTOMER	
CONTACT NAME	
CITY, STATE	
PHONE NUMBER	
E-MAIL	

GENERAL:

Boiler room air pressure (Note: Must be neutral pressure)		INCHES WC
Flue gas condensate drain maintains minimum slope and trap height?	<input type="checkbox"/> YES <input type="checkbox"/> NO	
Water fill pressure at the boiler outlet/supply connection (>12 PSI)		PSI

COMBUSTION-AIR SUPPLY FROM BOILER ROOM ONLY:

If boiler room, what is the Upper Louver Size? (In inches)	LENGTH _____	HEIGHT _____
If boiler room, what is the Lower Louver Size?	LENGTH _____	HEIGHT _____
Combustion air louver type	<input type="checkbox"/> FIXED	<input type="checkbox"/> MOTORIZED
If motorized, are they interlocked with the boilers?	<input type="checkbox"/> YES	<input type="checkbox"/> NO <input type="checkbox"/> N/A

COMBUSTION-AIR SUPPLY DUCTED DIRECTLY TO BOILER ONLY:

Combustion air intake material type (e.g.: PVC, Spiral Metal Duct, etc.)	
Air intake termination location	<input type="checkbox"/> ROOFTOP <input type="checkbox"/> SIDEWALL
Intake configuration	<input type="checkbox"/> INDIVIDUAL <input type="checkbox"/> COMMON
Combustion air intake ducting diameter	_____ INCHES
Combustion air intake ducting length	_____ FEET
Combustion air intake elbow quantity	45'S _____ 90'S _____
Horizontal separation between intake and exhaust termination	_____ FEET
Vertical separation between intake and exhaust termination	_____ FEET

FLUE GAS EXHAUST VENT CONFIGURATION:

Flue gas exhaust vent material type (e.g. Stainless, Polypropylene, etc.)	
Exhaust termination location	<input type="checkbox"/> ROOFTOP <input type="checkbox"/> SIDEWALL
Exhaust configuration	<input type="checkbox"/> INDIVIDUAL <input type="checkbox"/> COMMON
Venting inside diameter	_____ INCHES
Total Venting length (Rise + Run)	_____ FEET
Vertical rise only	_____ FEET
Elbows quantity	45'S _____ 90'S _____
Is an exhaust fan installed?	<input type="checkbox"/> YES <input type="checkbox"/> NO
Exhaust fan setpoint pressure	_____ INCHES WC
Common vent pressure with all boilers at (Note: Do not measure at boiler flue outlet)	HIGH FIRE _____ LOW FIRE _____
Does the boiler have a modulating draft damper?	<input type="checkbox"/> YES <input type="checkbox"/> NO
Does the common exhaust have a modulating draft damper?	<input type="checkbox"/> YES <input type="checkbox"/> NO <input type="checkbox"/> N/A

CONTROLS:

Boiler setpoint source (i.e. BMS, OAT, 4-20mA, Local)	_____		
Is the boiler configured for internal lead/lag?	<input type="checkbox"/> YES	<input type="checkbox"/> NO	
Motorized isolation valve wired and functional? (Note: Variable-Primary only)	<input type="checkbox"/> YES	<input type="checkbox"/> NO	<input type="checkbox"/> N/A
Dedicated primary pump wired and functional? (Note: Primary-Secondary only)	<input type="checkbox"/> YES	<input type="checkbox"/> NO	<input type="checkbox"/> N/A
Software update performed?*	<input type="checkbox"/> YES	<input type="checkbox"/> NO	
Software version in use:	VERSION: _____		

**Do not skip this step unless instructed by the factory.*

SAFETY CHECKS: Check all safeties below for proper operation and document the final settings.

DEVICE	SETTING	OPERATIONAL
Low Water Safety		
Air Switch		
Low Gas Pressure Switch		
High Gas Pressure Switch		
Blocked Exhaust Switch		

DEVICE	SETTING	OPERATIONAL
High Temperature Limit		
Fuel Train Leak Test		
Blower/Premix Leak Test		

COMBUSTION SETTINGS: Fuel Type is: *Natural Gas* *Propane*

FIRING POSITION:	P0 LIGHT	P1	P2	P3	P4	P5	P6	P7	P8	P9 100%
Fuel Position										
Air Position										
Blower Position										
Blower Ampere										
Incoming Voltage										
Supply Gas Pressure (InWC)*										
Manifold Gas Pressure (InWC)*										
MV Downstream Gas (InWC)*										
Fan Discharge Pressure (InWC)*										
Analyzer O2%										
CO2 %										
CO ppm										
NOx @ 3%										
Room Ambient Temp. °F										
Combustion Air Temp. °F										
Stack Temperature °F										
Stack Draft (InWC)*										
Inlet Water Temp. °F										
Outlet Water Temp. °F										
Main Flame Signal										

** Use only a Slack Tube® Manometer or equivalent. The use of a digital manometer is not recommended.*

When complete, please keep this form with the boiler, store a record copy in a safe location, and return a copy to Fulton:

Fulton
ATTN: Service Coordinator
972 Centerville Road
Pulaski, New York 13142

Phone: (315) 298-5121 • Fax: (315) 298-6390



ENDURA (EDR)
ANNUAL MAINTENANCE CHECKLIST

NOTE:

TO BE COMPLETED BY A FACTORY AUTHORIZED TECHNICIAN HOLDING A VALID ENDURA (EDR) CERTIFICATE OF REGISTRATION.

DATE	
TECHNICIAN	
TECH. COMPANY	

TECH CERTIFICATE #	
BOILER MODEL	
BOILER NB/SERIAL #	

ANNUAL MAINTENANCE:

Burner head removed and visually inspected	<input type="checkbox"/>	COMPLETE
Burner head cleaned (air only)	<input type="checkbox"/>	COMPLETE
Burner head reinstalled with new gaskets	<input type="checkbox"/>	COMPLETE
Burner flange hardware torqued to spec (see Section 4 of IOM)	<input type="checkbox"/>	COMPLETE
Low water probe(s) removed, cleaned, and reinstalled	<input type="checkbox"/>	COMPLETE
Combustion air inlet filter replaced with new	<input type="checkbox"/>	COMPLETE
Flame rod inspected and cleaned, or replaced	<input type="checkbox"/>	COMPLETE
Direct spark ignition replaced with new and gap properly set	<input type="checkbox"/>	COMPLETE
Special gas vent system and condensate drains inspected	<input type="checkbox"/>	COMPLETE
Combustion air intake system inspected	<input type="checkbox"/>	COMPLETE
Safety relief valve tested, replaced if it does not fully reseal	<input type="checkbox"/>	COMPLETE
Open factory Service Bulletin(s) addressed (where applicable)	<input type="checkbox"/>	COMPLETE
Software updated to the latest version (unless otherwise instructed by the factory)	<input type="checkbox"/>	COMPLETE
Safety checks table completed		(fill in tables below)
Combustion verification completed, adjust as necessary		(fill in tables on reverse side)

WATER CHEMISTRY: *Verify water chemistry is within specified limits, correct where required*

pH (8.5-10.5)	_____	
Oxygen (<250 ppb)	_____	ppb
Iron/Copper (<5 ppm)	_____	ppm
Chloride (<200 ppm)	_____	ppm
Hardness (<60 ppm)	_____	ppm
Glycol %	_____	%
Water fill pressure at the boiler outlet/supply connection (>12 psi)	_____	psi

CONTROLS:

Software Version in Use	VERSION: _____
-------------------------	----------------

SAFETY CHECKS: *Check all safeties below for proper operation and document the final settings.*

DEVICE	SETTING	OPERATIONAL
Low Water Safety		
Air Switch		
Low Gas Pressure Switch		
High Gas Pressure Switch		
Blocked Exhaust Switch		

DEVICE	SETTING	OPERATIONAL
High Temperature Limit		
Fuel Train Leak Test		
Blower/Premix Leak Test		

COMBUSTION SETTINGS: Fuel Type is: *Natural Gas* *Propane*

FIRING POSITION:	P0 LIGHT	P1	P2	P3	P4	P5	P6	P7	P8	P9 100%
Fuel Position										
Air Position										
Blower Position										
Blower Ampere	▣	▣	▣	▣	▣	▣	▣	▣	▣	
Incoming Voltage	▣	▣	▣	▣	▣	▣	▣	▣	▣	
Supply Gas Pressure (InWC)*			▣	▣	▣	▣	▣	▣	▣	
Manifold Gas Pressure (InWC)*										
MV Downstream Gas (InWC)*			▣	▣	▣	▣	▣	▣	▣	
Fan Discharge Pressure (InWC)*			▣	▣	▣	▣	▣	▣	▣	
Analyzer O2%										
CO2 %										
CO ppm										
NOx @ 3%										
Room Ambient Temp. °F		▣	▣	▣	▣	▣	▣	▣	▣	
Combustion Air Temp. °F		▣	▣	▣	▣	▣	▣	▣	▣	
Stack Temperature °F	▣	▣	▣	▣	▣	▣	▣	▣	▣	
Stack Draft (InWC)*										
Inlet Water Temp. °F	▣		▣	▣	▣	▣	▣	▣	▣	
Outlet Water Temp. °F	▣		▣	▣	▣	▣	▣	▣	▣	
Main Flame Signal										

* Use only a Slack Tube® Manometer or equivalent. The use of a digital manometer is not recommended.

OPERATING HISTORY

Boiler Online Hours	
Boiler Run Hours	
Boiler Cycles	

When complete, please keep this form with the boiler and store a record copy in a safe location. Accurate and complete combustion and maintenance records detailing compliance with the Installation, Operation, and Maintenance Manual must be produced for warranty consideration. Please use photocopies or consult your local Fulton Representative for additional copies of this form.



ENDURA (EDR)
ANNUAL MAINTENANCE CHECKLIST

NOTE:

TO BE COMPLETED BY A FACTORY AUTHORIZED TECHNICIAN HOLDING A VALID ENDURA (EDR) CERTIFICATE OF REGISTRATION.

DATE	
TECHNICIAN	
TECH. COMPANY	

TECH CERTIFICATE #	
BOILER MODEL	
BOILER NB/SERIAL #	

ANNUAL MAINTENANCE:

Burner head removed and visually inspected	<input type="checkbox"/>	COMPLETE
Burner head cleaned (air only)	<input type="checkbox"/>	COMPLETE
Burner head reinstalled with new gaskets	<input type="checkbox"/>	COMPLETE
Burner flange hardware torqued to spec (see Section 4 of IOM)	<input type="checkbox"/>	COMPLETE
Low water probe(s) removed, cleaned, and reinstalled	<input type="checkbox"/>	COMPLETE
Combustion air inlet filter replaced with new	<input type="checkbox"/>	COMPLETE
Flame rod inspected and cleaned, or replaced	<input type="checkbox"/>	COMPLETE
Direct spark ignition replaced with new and gap properly set	<input type="checkbox"/>	COMPLETE
Special gas vent system and condensate drains inspected	<input type="checkbox"/>	COMPLETE
Combustion air intake system inspected	<input type="checkbox"/>	COMPLETE
Safety relief valve tested, replaced if it does not fully reseal	<input type="checkbox"/>	COMPLETE
Open factory Service Bulletin(s) addressed (where applicable)	<input type="checkbox"/>	COMPLETE
Software updated to the latest version (unless otherwise instructed by the factory)	<input type="checkbox"/>	COMPLETE
Safety checks table completed		(fill in tables below)
Combustion verification completed, adjust as necessary		(fill in tables on reverse side)

WATER CHEMISTRY: *Verify water chemistry is within specified limits, correct where required*

pH (8.5-10.5)	_____	
Oxygen (<250 ppb)	_____	ppb
Iron/Copper (<5 ppm)	_____	ppm
Chloride (<200 ppm)	_____	ppm
Hardness (<60 ppm)	_____	ppm
Glycol %	_____	%
Water fill pressure at the boiler outlet/supply connection (>12 psi)	_____	psi

CONTROLS:

Software Version in Use	VERSION: _____
-------------------------	----------------

SAFETY CHECKS: *Check all safeties below for proper operation and document the final settings.*

DEVICE	SETTING	OPERATIONAL
Low Water Safety		
Air Switch		
Low Gas Pressure Switch		
High Gas Pressure Switch		
Blocked Exhaust Switch		

DEVICE	SETTING	OPERATIONAL
High Temperature Limit		
Fuel Train Leak Test		
Blower/Premix Leak Test		

COMBUSTION SETTINGS: Fuel Type is: *Natural Gas* *Propane*

FIRING POSITION:	P0 LIGHT	P1	P2	P3	P4	P5	P6	P7	P8	P9 100%
Fuel Position										
Air Position										
Blower Position										
Blower Ampere	▣	▣	▣	▣	▣	▣	▣	▣	▣	
Incoming Voltage	▣	▣	▣	▣	▣	▣	▣	▣	▣	
Supply Gas Pressure (InWC)*			▣	▣	▣	▣	▣	▣	▣	
Manifold Gas Pressure (InWC)*										
MV Downstream Gas (InWC)*			▣	▣	▣	▣	▣	▣	▣	
Fan Discharge Pressure (InWC)*			▣	▣	▣	▣	▣	▣	▣	
Analyzer O2%										
CO2 %										
CO ppm										
NOx @ 3%										
Room Ambient Temp. °F		▣	▣	▣	▣	▣	▣	▣	▣	
Combustion Air Temp. °F		▣	▣	▣	▣	▣	▣	▣	▣	
Stack Temperature °F	▣	▣	▣	▣	▣	▣	▣	▣	▣	
Stack Draft (InWC)*										
Inlet Water Temp. °F	▣		▣	▣	▣	▣	▣	▣	▣	
Outlet Water Temp. °F	▣		▣	▣	▣	▣	▣	▣	▣	
Main Flame Signal										

* Use only a Slack Tube® Manometer or equivalent. The use of a digital manometer is not recommended.

OPERATING HISTORY

Boiler Online Hours	
Boiler Run Hours	
Boiler Cycles	

When complete, please keep this form with the boiler and store a record copy in a safe location. Accurate and complete combustion and maintenance records detailing compliance with the Installation, Operation, and Maintenance Manual must be produced for warranty consideration. Please use photocopies or consult your local Fulton Representative for additional copies of this form.



ENDURA (EDR)
ANNUAL MAINTENANCE CHECKLIST

NOTE:

TO BE COMPLETED BY A FACTORY AUTHORIZED TECHNICIAN HOLDING A VALID ENDURA (EDR) CERTIFICATE OF REGISTRATION.

DATE	
TECHNICIAN	
TECH. COMPANY	

TECH CERTIFICATE #	
BOILER MODEL	
BOILER NB/SERIAL #	

ANNUAL MAINTENANCE:

Burner head removed and visually inspected	<input type="checkbox"/>	COMPLETE
Burner head cleaned (air only)	<input type="checkbox"/>	COMPLETE
Burner head reinstalled with new gaskets	<input type="checkbox"/>	COMPLETE
Burner flange hardware torqued to spec (see Section 4 of IOM)	<input type="checkbox"/>	COMPLETE
Low water probe(s) removed, cleaned, and reinstalled	<input type="checkbox"/>	COMPLETE
Combustion air inlet filter replaced with new	<input type="checkbox"/>	COMPLETE
Flame rod inspected and cleaned, or replaced	<input type="checkbox"/>	COMPLETE
Direct spark ignition replaced with new and gap properly set	<input type="checkbox"/>	COMPLETE
Special gas vent system and condensate drains inspected	<input type="checkbox"/>	COMPLETE
Combustion air intake system inspected	<input type="checkbox"/>	COMPLETE
Safety relief valve tested, replaced if it does not fully reseal	<input type="checkbox"/>	COMPLETE
Open factory Service Bulletin(s) addressed (where applicable)	<input type="checkbox"/>	COMPLETE
Software updated to the latest version (unless otherwise instructed by the factory)	<input type="checkbox"/>	COMPLETE
Safety checks table completed		(fill in tables below)
Combustion verification completed, adjust as necessary		(fill in tables on reverse side)

WATER CHEMISTRY: *Verify water chemistry is within specified limits, correct where required*

pH (8.5-10.5)	_____	
Oxygen (<250 ppb)	_____	ppb
Iron/Copper (<5 ppm)	_____	ppm
Chloride (<200 ppm)	_____	ppm
Hardness (<60 ppm)	_____	ppm
Glycol %	_____	%
Water fill pressure at the boiler outlet/supply connection (>12 psi)	_____	psi

CONTROLS:

Software Version in Use	VERSION: _____
-------------------------	----------------

SAFETY CHECKS: *Check all safeties below for proper operation and document the final settings.*

DEVICE	SETTING	OPERATIONAL
Low Water Safety		
Air Switch		
Low Gas Pressure Switch		
High Gas Pressure Switch		
Blocked Exhaust Switch		

DEVICE	SETTING	OPERATIONAL
High Temperature Limit		
Fuel Train Leak Test		
Blower/Premix Leak Test		

COMBUSTION SETTINGS: Fuel Type is: *Natural Gas* *Propane*

FIRING POSITION:	P0 LIGHT	P1	P2	P3	P4	P5	P6	P7	P8	P9 100%
Fuel Position										
Air Position										
Blower Position										
Blower Ampere	▣	▣	▣	▣	▣	▣	▣	▣	▣	
Incoming Voltage	▣	▣	▣	▣	▣	▣	▣	▣	▣	
Supply Gas Pressure (InWC)*			▣	▣	▣	▣	▣	▣	▣	
Manifold Gas Pressure (InWC)*										
MV Downstream Gas (InWC)*			▣	▣	▣	▣	▣	▣	▣	
Fan Discharge Pressure (InWC)*			▣	▣	▣	▣	▣	▣	▣	
Analyzer O2%										
CO2 %										
CO ppm										
NOx @ 3%										
Room Ambient Temp. °F		▣	▣	▣	▣	▣	▣	▣	▣	
Combustion Air Temp. °F		▣	▣	▣	▣	▣	▣	▣	▣	
Stack Temperature °F	▣	▣	▣	▣	▣	▣	▣	▣	▣	
Stack Draft (InWC)*										
Inlet Water Temp. °F	▣		▣	▣	▣	▣	▣	▣	▣	
Outlet Water Temp. °F	▣		▣	▣	▣	▣	▣	▣	▣	
Main Flame Signal										

* Use only a Slack Tube® Manometer or equivalent. The use of a digital manometer is not recommended.

OPERATING HISTORY

Boiler Online Hours	
Boiler Run Hours	
Boiler Cycles	

When complete, please keep this form with the boiler and store a record copy in a safe location. Accurate and complete combustion and maintenance records detailing compliance with the Installation, Operation, and Maintenance Manual must be produced for warranty consideration. Please use photocopies or consult your local Fulton Representative for additional copies of this form.



ENDURA (EDR)
ANNUAL MAINTENANCE CHECKLIST

NOTE:

TO BE COMPLETED BY A FACTORY AUTHORIZED TECHNICIAN HOLDING A VALID ENDURA (EDR) CERTIFICATE OF REGISTRATION.

DATE	
TECHNICIAN	
TECH. COMPANY	

TECH CERTIFICATE #	
BOILER MODEL	
BOILER NB/SERIAL #	

ANNUAL MAINTENANCE:

Burner head removed and visually inspected	<input type="checkbox"/>	COMPLETE
Burner head cleaned (air only)	<input type="checkbox"/>	COMPLETE
Burner head reinstalled with new gaskets	<input type="checkbox"/>	COMPLETE
Burner flange hardware torqued to spec (see Section 4 of IOM)	<input type="checkbox"/>	COMPLETE
Low water probe(s) removed, cleaned, and reinstalled	<input type="checkbox"/>	COMPLETE
Combustion air inlet filter replaced with new	<input type="checkbox"/>	COMPLETE
Flame rod inspected and cleaned, or replaced	<input type="checkbox"/>	COMPLETE
Direct spark ignition replaced with new and gap properly set	<input type="checkbox"/>	COMPLETE
Special gas vent system and condensate drains inspected	<input type="checkbox"/>	COMPLETE
Combustion air intake system inspected	<input type="checkbox"/>	COMPLETE
Safety relief valve tested, replaced if it does not fully reseal	<input type="checkbox"/>	COMPLETE
Open factory Service Bulletin(s) addressed (where applicable)	<input type="checkbox"/>	COMPLETE
Software updated to the latest version (unless otherwise instructed by the factory)	<input type="checkbox"/>	COMPLETE
Safety checks table completed		(fill in tables below)
Combustion verification completed, adjust as necessary		(fill in tables on reverse side)

WATER CHEMISTRY: *Verify water chemistry is within specified limits, correct where required*

pH (8.5-10.5)	_____	
Oxygen (<250 ppb)	_____	ppb
Iron/Copper (<5 ppm)	_____	ppm
Chloride (<200 ppm)	_____	ppm
Hardness (<60 ppm)	_____	ppm
Glycol %	_____	%
Water fill pressure at the boiler outlet/supply connection (>12 psi)	_____	psi

CONTROLS:

Software Version in Use	VERSION: _____
-------------------------	----------------

SAFETY CHECKS: *Check all safeties below for proper operation and document the final settings.*

DEVICE	SETTING	OPERATIONAL
Low Water Safety		
Air Switch		
Low Gas Pressure Switch		
High Gas Pressure Switch		
Blocked Exhaust Switch		

DEVICE	SETTING	OPERATIONAL
High Temperature Limit		
Fuel Train Leak Test		
Blower/Premix Leak Test		

COMBUSTION SETTINGS: Fuel Type is: *Natural Gas* *Propane*

FIRING POSITION:	P0 LIGHT	P1	P2	P3	P4	P5	P6	P7	P8	P9 100%
Fuel Position										
Air Position										
Blower Position										
Blower Ampere	▣	▣	▣	▣	▣	▣	▣	▣	▣	
Incoming Voltage	▣	▣	▣	▣	▣	▣	▣	▣	▣	
Supply Gas Pressure (InWC)*			▣	▣	▣	▣	▣	▣	▣	
Manifold Gas Pressure (InWC)*										
MV Downstream Gas (InWC)*			▣	▣	▣	▣	▣	▣	▣	
Fan Discharge Pressure (InWC)*			▣	▣	▣	▣	▣	▣	▣	
Analyzer O2%										
CO2 %										
CO ppm										
NOx @ 3%										
Room Ambient Temp. °F		▣	▣	▣	▣	▣	▣	▣	▣	
Combustion Air Temp. °F		▣	▣	▣	▣	▣	▣	▣	▣	
Stack Temperature °F	▣	▣	▣	▣	▣	▣	▣	▣	▣	
Stack Draft (InWC)*										
Inlet Water Temp. °F	▣		▣	▣	▣	▣	▣	▣	▣	
Outlet Water Temp. °F	▣		▣	▣	▣	▣	▣	▣	▣	
Main Flame Signal										

* Use only a Slack Tube® Manometer or equivalent. The use of a digital manometer is not recommended.

OPERATING HISTORY

Boiler Online Hours	
Boiler Run Hours	
Boiler Cycles	

When complete, please keep this form with the boiler and store a record copy in a safe location. Accurate and complete combustion and maintenance records detailing compliance with the Installation, Operation, and Maintenance Manual must be produced for warranty consideration. Please use photocopies or consult your local Fulton Representative for additional copies of this form.



ENDURA (EDR)
ANNUAL MAINTENANCE CHECKLIST

NOTE:

TO BE COMPLETED BY A FACTORY AUTHORIZED TECHNICIAN HOLDING A VALID ENDURA (EDR) CERTIFICATE OF REGISTRATION.

DATE	
TECHNICIAN	
TECH. COMPANY	

TECH CERTIFICATE #	
BOILER MODEL	
BOILER NB/SERIAL #	

ANNUAL MAINTENANCE:

Burner head removed and visually inspected	<input type="checkbox"/>	COMPLETE
Burner head cleaned (air only)	<input type="checkbox"/>	COMPLETE
Burner head reinstalled with new gaskets	<input type="checkbox"/>	COMPLETE
Burner flange hardware torqued to spec (see Section 4 of IOM)	<input type="checkbox"/>	COMPLETE
Low water probe(s) removed, cleaned, and reinstalled	<input type="checkbox"/>	COMPLETE
Combustion air inlet filter replaced with new	<input type="checkbox"/>	COMPLETE
Flame rod inspected and cleaned, or replaced	<input type="checkbox"/>	COMPLETE
Direct spark ignition replaced with new and gap properly set	<input type="checkbox"/>	COMPLETE
Special gas vent system and condensate drains inspected	<input type="checkbox"/>	COMPLETE
Combustion air intake system inspected	<input type="checkbox"/>	COMPLETE
Safety relief valve tested, replaced if it does not fully reseal	<input type="checkbox"/>	COMPLETE
Open factory Service Bulletin(s) addressed (where applicable)	<input type="checkbox"/>	COMPLETE
Software updated to the latest version (unless otherwise instructed by the factory)	<input type="checkbox"/>	COMPLETE
Safety checks table completed		(fill in tables below)
Combustion verification completed, adjust as necessary		(fill in tables on reverse side)

WATER CHEMISTRY: *Verify water chemistry is within specified limits, correct where required*

pH (8.5-10.5)	_____	
Oxygen (<250 ppb)	_____	ppb
Iron/Copper (<5 ppm)	_____	ppm
Chloride (<200 ppm)	_____	ppm
Hardness (<60 ppm)	_____	ppm
Glycol %	_____	%
Water fill pressure at the boiler outlet/supply connection (>12 psi)	_____	psi

CONTROLS:

Software Version in Use	VERSION: _____
-------------------------	----------------

SAFETY CHECKS: *Check all safeties below for proper operation and document the final settings.*

DEVICE	SETTING	OPERATIONAL
Low Water Safety		
Air Switch		
Low Gas Pressure Switch		
High Gas Pressure Switch		
Blocked Exhaust Switch		

DEVICE	SETTING	OPERATIONAL
High Temperature Limit		
Fuel Train Leak Test		
Blower/Premix Leak Test		

COMBUSTION SETTINGS: Fuel Type is: *Natural Gas* *Propane*

FIRING POSITION:	P0 LIGHT	P1	P2	P3	P4	P5	P6	P7	P8	P9 100%
Fuel Position										
Air Position										
Blower Position										
Blower Ampere	▣	▣	▣	▣	▣	▣	▣	▣	▣	
Incoming Voltage	▣	▣	▣	▣	▣	▣	▣	▣	▣	
Supply Gas Pressure (InWC)*			▣	▣	▣	▣	▣	▣	▣	
Manifold Gas Pressure (InWC)*										
MV Downstream Gas (InWC)*			▣	▣	▣	▣	▣	▣	▣	
Fan Discharge Pressure (InWC)*			▣	▣	▣	▣	▣	▣	▣	
Analyzer O2%										
CO2 %										
CO ppm										
NOx @ 3%										
Room Ambient Temp. °F		▣	▣	▣	▣	▣	▣	▣	▣	
Combustion Air Temp. °F		▣	▣	▣	▣	▣	▣	▣	▣	
Stack Temperature °F	▣	▣	▣	▣	▣	▣	▣	▣	▣	
Stack Draft (InWC)*										
Inlet Water Temp. °F	▣		▣	▣	▣	▣	▣	▣	▣	
Outlet Water Temp. °F	▣		▣	▣	▣	▣	▣	▣	▣	
Main Flame Signal										

* Use only a Slack Tube® Manometer or equivalent. The use of a digital manometer is not recommended.

OPERATING HISTORY

Boiler Online Hours	
Boiler Run Hours	
Boiler Cycles	

When complete, please keep this form with the boiler and store a record copy in a safe location. Accurate and complete combustion and maintenance records detailing compliance with the Installation, Operation, and Maintenance Manual must be produced for warranty consideration. Please use photocopies or consult your local Fulton Representative for additional copies of this form.

No part of this Installation, Operation, and Maintenance manual may be reproduced in any form or by any means without permission in writing from Fulton Group N.A., Inc.

Fulton Thermal Corporation is part of Fulton Group N.A., Inc., a global manufacturer of steam, hot water and thermal fluid heat transfer systems. Fulton Steam Solutions, Inc. & Fulton Heating Solutions, Inc. are now Fulton Thermal Corporation.

© Fulton Group N.A., Inc. 2025



972 Centerville Road, Pulaski, NY 13142
Call: (315) 298-5121 • Fax: (315) 298-6390



www.fulton.com

EDR-PURE-IOM-250219