

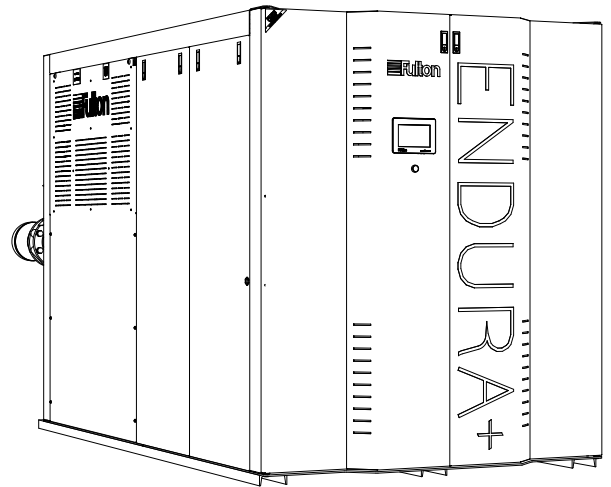

INSTALLATION, OPERATION, AND MAINTENANCE MANUAL

Endura+ (EDR+)
Condensing Hydronic Boilers
8,000,000 - 12,000,000 BTU/HR



Serial/ National Board Numbers _____

Model _____

Fulton Order _____

Owner _____

Site Name _____

Date _____



PAGE LEFT INTENTIONALLY BLANK

Introduction	1-1	Operation	3-1
Overview	1-2	Perform Pre-Start-Up Inspection.....	3-2
Warnings & Cautions.....	1-2	Fill and Purge the System.....	3-2
Disclaimers and Local Codes	1-2	Commission The Boiler.....	3-3
Installation	2-1	SYSTEM DESIGN AND BOILER OPERATION	3-3
Product Overview.....	2-2	TURNDOWN	3-4
Massachusetts Installations	2-2	Operation Modifiers	3-4
Placement & Rigging	2-3	Siemens LMV3 Control	3-4
Clearances and Serviceability	2-5	BEFORE MODIFYING LMV PARAMETERS.....	3-6
Install Boiler Trim	2-5	STEPS TO ENTER PARAMETERS	3-6
Install Water Piping.....	2-6	ADJUSTING FUEL/AIR CURVE	3-6
VARIABLE PRIMARY PIPING ARRANGEMENT	2-7	PARAMETER BACKUP	3-9
PRIMARY-SECONDARY PIPING ARRANGEMENT.....	2-10	PARAMETER RESTORE	3-10
Meet Water Chemistry Requirements.....	2-11	Using the Endura+ PURE Control™ Interface	3-12
PREVENT OXYGEN CONTAMINATION.....	2-12	NAVIGATION.....	3-12
ELIMINATE SYSTEM AIR	2-12	Endura+ PURE Control™ Menu Screen Functions	3-13
Fill the Boiler with Water.....	2-12	BOILER CONTROL.....	3-13
Gas Supply Piping	2-12	LEAD/LAG.....	3-16
INLET GAS PRESSURE	2-12	PID CONTROL	3-17
LINE GAS PRESSURE REGULATION.....	2-13	SETPOINT	3-18
GAS PIPING INSTALLATION	2-13	SCHEDULING	3-18
MULTIPLE BOILER INSTALLATION.....	2-15	TRENDING.....	3-18
COMPONENTS REQUIRING VENTILATION TO THE OUTDOORS	2-15	ADMIN.....	3-19
Install Condensate Drain Trap.....	2-16	Commissioning Mode	3-20
Install pH Neutralization Kit.....	2-18	Perform Test of Limit Controls	3-20
Venting Requirements	2-19	Perform Test of Low Gas Pressure Switch	3-20
Combustion Air Intake	2-20	Perform Test of High Gas Pressure Switch.....	3-20
COMBUSTION AIR SUPPLY FROM THE BOILER ROOM.....	2-21	General Operation of the Boiler	3-20
COMBUSTION AIR DUCTED FROM THE OUTDOORS.....	2-22	Maintenance	4-1
Combustion Air Filter	2-23	General.....	4-2
Flue Gas Exhaust Venting	2-23	Daily Maintenance and Inspection Schedule	4-2
Common Flue Gas Venting Layouts.....	2-25	Weekly Maintenance and Inspection Schedule	4-2
COMMON VENTING EXHAUST BACKFLOW PREVENTION.....	2-25	Monthly Maintenance and Inspection Schedule.....	4-3
Venting Terminations.....	2-26	Replacing the Combustion Air Inlet Filter	4-3
WALL THIMBLE INSTALLATION	2-30	Replacing or Updating the Boiler Control	4-3
ROOF VENT TERMINATION.....	2-30	Annual Maintenance and Inspection Schedule	4-4
SIDE WALL VENT TERMINATION.....	2-31	O ₂ Compensation Measurement.....	4-4
Removing an Existing Boiler	2-31	Removing, Inspecting and Cleaning Burner	4-5
Assembly of Fulton Multi-Skid Systems.....	2-32	Inspecting the Pilot Ignition Assembly.....	4-6
Electrical Connections and Devices	2-33	After All Repairs and Maintenance	4-7
JUNCTION BOX LOCATIONS FOR FIELD WIRING	2-36	Troubleshooting	4-10
ELECTRICAL AND CONTROLS OPTIONS.....	2-36		

Service Documents **5-1**

Pre-Commissioning Installation Checklist 5-3
Installation & Operation Report..... 5-5
Annual Maintenance Report(s)..... 5-7
Notes 5-17

INTRODUCTION

1

INSTALLATION

2

OPERATION

3

MAINTENANCE

4

SERVICE DOCUMENTS

5

Overview

Prior to shipment, the following inspections and tests are made to ensure the highest standards of manufacturing for our customers:

- Material inspections
- Manufacturing process inspections
- American Society of Mechanical Engineers (ASME) welding inspection
- ASME hydrostatic test inspection
- Electrical components inspection
- Operating test
- Final engineering inspection
- Crating inspection

This manual is provided as a guide to the correct operation and maintenance of your Fulton equipment, and should be read in its entirety and be made permanently available to the staff responsible for the operation of the boiler. It should not, however, be considered as a complete code of practice, nor should it replace existing codes or standards which may be applicable. Fulton reserves the right to change any part of this installation, operation and maintenance manual.

Installation, start-up, and maintenance of this equipment can be hazardous and requires trained, qualified installers and service personnel. **Trained personnel are responsible for the installation, operation, and maintenance of this product, and for the safety assurance of installation, operation, and maintenance processes. Do not install, operate, service or repair any component of this equipment unless you are qualified and fully understand all requirements and procedures. Trained personnel refers to those who have successfully completed Fulton Service School training specific to this product.**

When working on this equipment, observe all warnings, cautions, and notes in literature, on stickers and labels, and any additional safety precautions that apply. Follow all safety codes and wear appropriate safety protection. Follow all jurisdictional codes and consult any jurisdictional authorities prior to installation.

Warnings & Cautions

WARNINGS and CAUTIONS appear in various chapters of this manual. It is critical that all personnel read and adhere to all information contained in WARNINGS and CAUTIONS.

- WARNINGS must be observed to prevent serious injury or death to personnel.
- CAUTIONS must be observed to prevent damage or destruction of equipment or loss of operating effectiveness.

All Warnings and Cautions are for reference and guidance purposes, and do not substitute for required professional training, conduct, and strict adherence to applicable jurisdictional/professional codes or regulations.

Disclaimers and Local Codes

Installation of the equipment shall conform to all the requirements or all national, state and local codes established by the authorities having jurisdiction or, in the absence of such requirements, in the US to the National Fuel Gas Code ANSI Z223.1/NFPA 54 latest edition, and the specific instructions in this manual. Authorities having jurisdiction should be consulted prior to installation.

When required by local codes, the installation must conform to the American Society of Mechanical Engineers Safety Code for Controls and Safety Devices for Automatically Fired Boilers (ASME CSD-1).

The boiler heat exchanger is manufactured and stamped in accordance with ASME Boiler and Pressure Vessel Code, Section IV for a maximum allowable working pressure and operating temperature of 160 psig and 210°F (99°C) respectively.

INTRODUCTION

1

INSTALLATION

2

OPERATION

3

MAINTENANCE

4

SERVICE DOCUMENTS

5

WARNING

All information in this manual is for reference and guidance purposes, and does not substitute for required professional training, conduct, and strict adherence to applicable jurisdictional/professional codes and regulations.

CAUTION

The standard configuration for this boiler is certified for indoor installation only.

This boiler is not designed for use in systems where water is continuously replenished. The warranty is valid for closed loop systems only.

Fulton cannot be held responsible for the selection, engineering, installation, or sizing of any additional equipment or components of the hydronic heating system.

Always verify gas type and pressure ratings for your boiler by viewing the boiler name plate.

Product Overview

Prior to the performance of installation, operation, or maintenance procedures, personnel should become familiar with the equipment (Table 1 and Figure 1) and its components.

The Fulton Endura+ (EDR+) hot water boiler is an automatic, fuel-fired, ultra high-efficiency boiler. Combustion air supply may be ducted to the boiler from the outdoors or utilize conventional methods.

The boiler is capable of sidewall venting when the appropriate venting materials are used, and when permitted by local code requirements.

This boiler is ETL listed and labled to Underwriters Laboratories (UL) Edition 7 UL Standard for Safety Commercial-Industrial Gas Heating Equipment for indoor installation. The boiler heat exchanger is manufactured and bears the "H" stamp in accordance with American Society of Mechanical Engineers (ASME) Boiler and Pressure Vessel Code, Section IV for a maximum allowable working pressure and temperature of 160 psi and 210°F (99°C) respectively. It is hydrostatically tested, test fired and shipped as a complete packaged unit.

Fuel, water and electrical connections are similar to other boilers of this type.

Please be aware of which burner and control configuration has been designed specifically for your application.

This boiler is to be installed as part of a hydronic heating system. A qualified engineer must be consulted for the selection of the equipment and components of the heating system. Various system conditions can result in incorrect heat distribution to users of the heating system.

Each Endura+ Boiler is supplied with the following:

- Integrated combustion supervision and temperature operating controls
- Operating and high temperature probe(s) in pressure vessel
- Low water probe(s) in pressure vessel
- ASME safety relief valve
- Installation, Operation, and Maintenance Manual
- Test fire report
- Wiring diagram
- Temperature and pressure (T&P) gauge

The customer should examine the equipment for any damage. It is the responsibility of the installer to ensure all parts supplied with the equipment are fitted in a correct and safe manner.

Massachusetts Installations

Boilers installed in Massachusetts must have the following:

- A gas pressure regulator installed upstream of the gas train provided by the manufacturer or installing contractor.
- Two safety shutoff valves, in series, one of which is of the type incorporating a valve seal overtravel interlock when the maximum firing rate per combustion chamber exceeds 5,000,000 BTU/hour.

Placement & Rigging

Proper placement of your Fulton product is essential. Attention paid to the following points will save a great deal of difficulty in the future. Correct placement is the first step to trouble-free installation, operation, and maintenance.

Adhere to the following for placement and rigging:

1. Check building specifications for permissible floor loading. Use Table 1 for unit reference.
2. Conform to all the requirements of all national, state and local codes established by the authorities having jurisdiction and/or the U.S. to the National Fuel Gas Code, latest edition. Authorities having jurisdiction should be consulted before installations are made. Where required by local codes, the installation must conform to American Society of Mechanical Engineers Safety Code for Controls and Safety Devices for Automatically Fired Boilers (ASME CSD-1).
3. Since an external electrical source is utilized, the boiler, when installed, must be electrically ground in accordance with the National Electric Code, American National Standards Institute (ANSI) National Fire Protection Association (NFPA) 70, latest edition.
4. The boiler is designed for room temperatures above 32°F (0°C) and not exceeding 120°F (48.9°C).
5. Install so that all system components are protected from water (dripping, spraying, rain, etc.) and debris (dry wall dust, insulation particles, etc.) during boiler operation and service.
6. Install on a level, non-combustible surface. Concrete or steel is recommended. The surface must be elevated a minimum of 4" (102 mm) above the floor. The use of shims may be required to ensure the boiler is level. Do not install the boiler on springs.
7. Provide combustion and ventilation air in accordance with applicable provisions of local building codes or: USA – NFPA 54/ANSI Z223.1, Section 5.3, Air for Combustion and Ventilation.
8. Locate the boiler so that the combustion air supply and exhaust piping between the boiler and outside wall/roof are within the draft pressure requirements for horizontal or vertical venting. See **Clearances and Serviceability section** of this manual.



WARNING

All information in this manual is for reference and guidance purposes, and does not substitute for required professional training, conduct, and strict adherence to applicable jurisdictional/professional codes and regulations.

Competent personnel in accordance with all applicable local codes should carry out the installation of the Fulton equipment. All state and jurisdictional codes beyond the scope of the applicable ASME Boiler and Pressure Vessel Codes, for its corresponding classification, should be followed in all cases. Jurisdictional authorities must be consulted prior to installation.

A competent rigger experienced in handling heavy equipment should handle rigging your equipment into position.

The equipment must be installed on a non-combustible surface.

Failure to provide required and safe access to the equipment could impede commissioning and maintenance. Service technicians are instructed not to commence commissioning if hazardous conditions exist.

Failure to provide proper minimum clearances between equipment and combustible materials may result in fire.



CAUTION

Do not allow weight to bear on equipment components to prevent damage.

Do not use to directly heat a swimming pool.

TABLE 1 - BOILER DIMENSIONS AND OPERATING REQUIREMENTS

Specifications	EDR+	8000	10000	12000
Rated Input Capacity ¹	MBH	8,000	10,000	12,000
Minimum Input at Low Fire	MBH	400	400	400
Output at BTS-2000 conditions	MBH	7,568	9,450	11,508
Fuel Consumption at Capacity ²	SCFH	7,884	9,804	11,764
Nat. Gas Pressure Required ³	W.C.	8 - 28	8 - 28	8 - 28
Variable Water Flow	GPM	150 - 1400	150 - 1400	150 - 1400
Full Load Amps ⁴ (460/3/60)	AMP	46	46	46
Typical High Fire Amps ⁴ (460/3/60)	AMP	18	20	24
Typical Low Fire Amps ⁴ (460/3/60)	AMP	0.9	0.9	0.9
Water Content	GAL	360	360	360
Dry Weight	LBS	11,500	11,500	11,500
Operating Weight	LBS	14,502	14,502	14,502
Dimensions	EDR+	8000	10000	12000
A. Boiler Width	IN	66	66	66
B. Boiler Height	IN	79	79	79
C. Boiler Depth	IN	127	127	127
D. Flue Gas Stack ⁵ (dia)	IN	22	22	22
E. Combustion Air Inlet ⁵ (dia)	IN	18	18	18
F. Water Inlet/Outlet (dia)	IN	8	8	8
Minimum Clearance	EDR+	4000	10000	12000
G. Front	IN	36	36	36
H. Rear	IN	36	36	36
I. Top	IN	18	18	18
J. Sides	IN	24	24	24

¹Endura+ boilers may be operated up to 10,000 feet elevation, and up to 1,000 feet elevation at 80° F without de-rate. Consult your Fulton Representative for capacities at higher elevation.

²Applies to natural gas with a calorific value of 1,010 BTU per FT3.

³Standard natural gas configurations only. Alternate or custom configurations may have different requirements; always review the boiler nameplate before installation.

⁴Standard electrical configurations only. Alternate or custom configurations may have different requirements; always review the boiler nameplate before installation.

⁵An appliance manifold adapter is required.

NOTE: Specifications and dimensions are approximate and for reference only. Fulton practices continuous product improvement and reserves the right to change specifications and/or dimensions without notice.

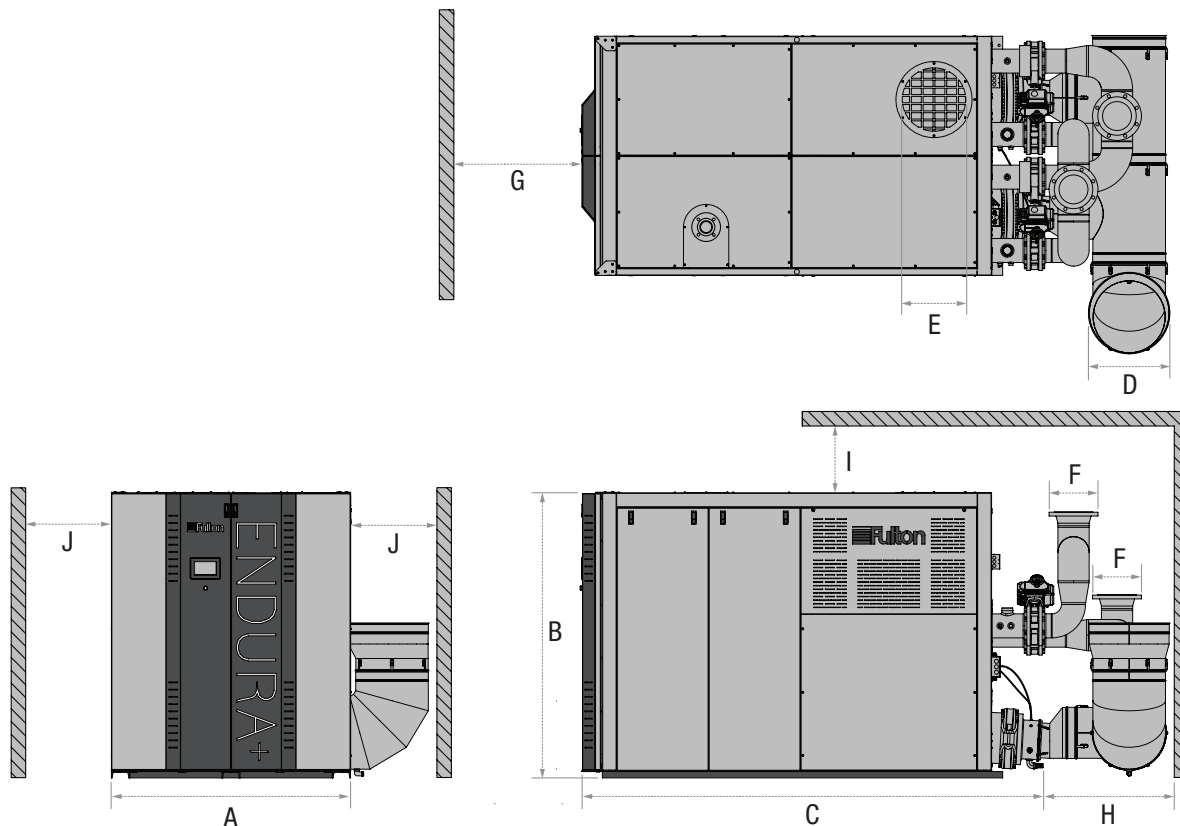

FIGURE 1 - SERVICE CLEARANCE

Clearances and Serviceability

Adhere to the following for clearances and serviceability:

1. All local and national codes (NFPA, ANSI, UL, CSA, ASME) must be followed for proper clearances and serviceability for your boiler or heater. Authorities having jurisdiction should be consulted before installations are made.
2. Appropriate front, back, side and top clearances must be maintained (Figure 1) to allow access around the equipment to facilitate maintenance and a safe work environment.
3. Ensure all labels on the boiler will be fully visible for maintenance and inspection.
4. Do not place or install any boiler room accessories, or other components, on the Endura+ cabinet panels.

Install Boiler Trim

Each packaged boiler is supplied with safety relief valves sized in accordance with ASME requirements. Adhere to the following installation requirements:

1. The safety relief valve (Figure 2) must:
 - » Be connected to the coupling located in the outlet of each heat engine module.
 - » Be installed in the upright vertical position.

- *NOTE: Safety relief valve size is determined by trim pressure and is supplied in the trim kit. For inlet and outlet sizes, see Table 2.*

TABLE 2 - SAFETY RELIEF VALVE INLET AND OUTLET SIZES (x2)

Model	Trim Pressure PSI (kPa)	Inlet Size inch (mm)	Outlet Size inch (mm)
EDR+ 8000	30 (206.84)	2 (50.8)	2 1/2 (63.5)
	60 (413.69)	1 1/2 (38.1)	2 (50.8)
EDR+ 10000	100 (689.48)	1 1/2 (38.1)	1 1/2 (38.1)
	125 (861.84)	1 1/4 (31.8)	1 1/4 (31.8)
EDR+ 12000	160 (1103.16)	1 (25.4)	1 1/4 (31.8)

2. The discharge pipe must:
 - » Not have a diameter less than the full area of the valve outlet.
 - » Be as short and straight as possible and so arranged as to avoid undue stress on the valve.
 - » Be supported by means other than the safety valve itself.
 - » Be piped to avoid danger of scalding personnel.

- *NOTE: Each module is supplied with a pressure-temperature gauge to be installed in the outlet piping section of the boiler. Gauge must not be isolated from the boiler by any valve.*

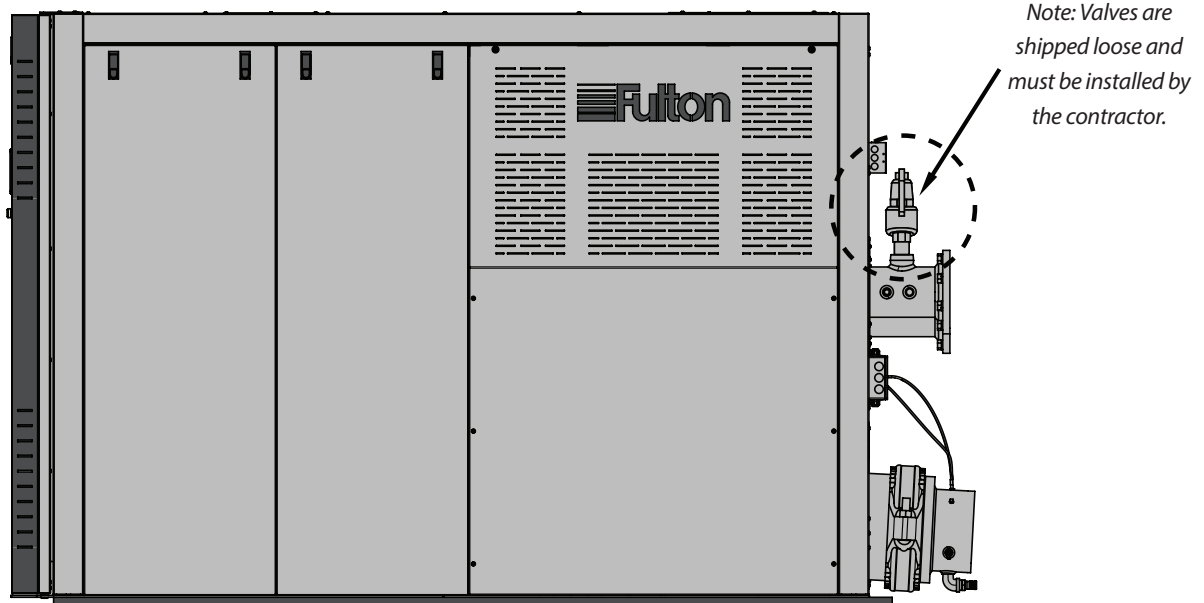

FIGURE 2 - SAFETY VALVE INSTALLATION LOCATION

WARNING

All information in this manual is for reference and guidance purposes, and does not substitute for required professional training, conduct, and strict adherence to applicable jurisdictional/professional codes and regulations.

The discharge from the safety relief valve must be arranged to ensure no danger of scalding personnel, or equipment damage.

Provisions must be made to properly pipe the safety relief discharge away from the boiler to the point of discharge.

No shutoff of any kind shall be placed between the safety relief valve and the boiler, or in the discharge pipe between the valve and the atmosphere. Doing so may cause an explosion from overpressure.

The hydronic system should never be flushed while the boiler is attached to the system since the debris could accumulate in the boiler and block water from passing through the heat exchanger.

For water-only systems, the water pressure at the boiler outlet must be 12 psi or greater at all times while the boiler is in operation. For systems using up to 50% glycol, a minimum of 30 psi is required at the boiler outlet.

Install Water Piping

All water supplies contain some solids, dissolved gases or dissolved minerals. These may cause corrosion, deposition and/or fouling of equipment. To prevent these contaminants from impacting boiler performance, valve operation and general pipe longevity, you must analyze and treat each installation uniquely.

Adhere to the following for water piping installation (see Figures 4 – 7):

- Manual isolation valves are recommended on both water connections for ease of service.
 - Install piping such that the boiler is not supporting any piping load.
 - Install manual purging valves in all loops and zones.
 - Install a pressure-reducing (automatic fill) valve in the cold water fill line to the boiler system.
- **NOTE: For water-only systems, the water pressure at the boiler outlet must be 12 psi or greater at all times while the boiler is in operation. For systems using up to 50% glycol, a minimum of 30 psi is required at the boiler outlet.**
- To prevent scale and corrosion in boiler and associated piping, make up water must be kept to a minimum. This is best achieved by ensuring immediate repair of all leaks and that system pressure is maintained.
 - Check that the proposed operation of zone valves, zone circulator(s) and diverting valves will not isolate air separator(s) and/ or expansion tank(s) from the boiler.
 - Provide at least 6 inches (152 mm) clearance from hot water pipes to combustibles.
 - When used with a refrigeration system, install the boiler so that the chilled medium is piped in parallel with the boiler with appropriate valves to prevent the chilled medium from entering the boiler. If the boilers are connected to heating coils (located in air handling units) where they may be exposed to refrigerated air circulation, such boiler piping systems must be equipped with flow control valves or other automatic means to prevent gravity circulation of the boiler water during the cooling cycle.
 - Include the following in the mechanical equipment in the hydronic heating system:
 - » *An automatic pressure activated water make up valve with back flow preventer.* It must be set to maintain required 12 psi or greater at boiler outlet, Net Positive Suction Head (NPSH) for re-circulating pumps, a positive system pressure at the highest point of at least 5-10 PSIG, and should be designed to add water to the system at the outlet of the boiler but should not be fed directly into the boiler.
 - » *Air removal equipment, including an air separator and automatic breather valves, along with a functioning expansion tank.* Each must be designed to system specifications.

- Boiler connection dimensions are for reference and not for construction purposes. Pre-fabricating boiler piping is not recommended.
- Install filtration in the common loop or per boiler to remove particulates. A #4 or finer mesh size is required.
- Install bypass chemical feeder for corrosion inhibitor maintenance if required to comply with water chemistry requirements.
- Install corrosion coupon holder to assess corrosion inhibitor performance if required to comply with water chemistry requirements.
- Before installing the boiler into a hydronic loop, be sure that the system piping and any other components of the system are clean and free of debris, ferrous oxide (magnetite), and any foreign matter. The hydronic system must be completely flushed prior to installing the boiler.

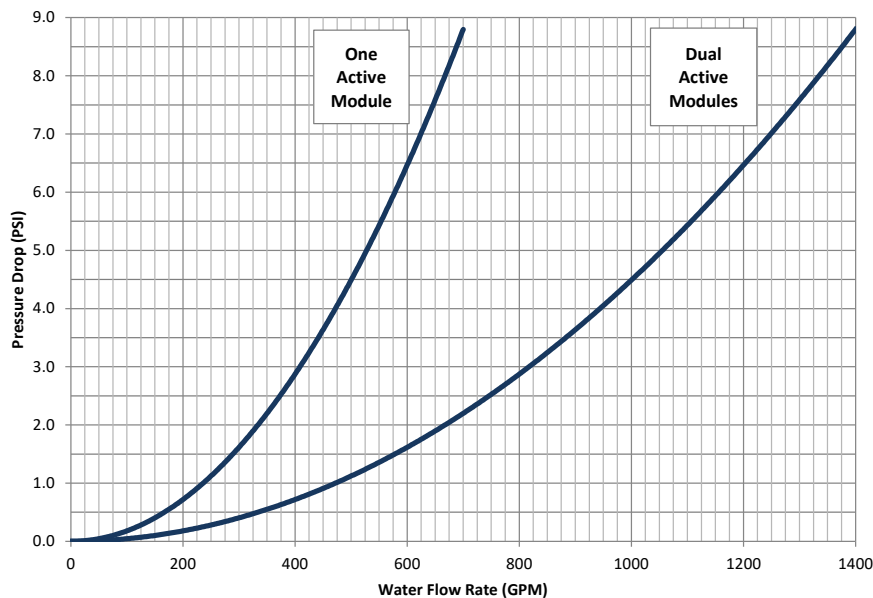

FIGURE 3 - TYPICAL WATER SIDE PRESSURE DROP

■ Variable Primary Piping Arrangement

This boiler is designed for installation in variable primary flow piping arrangements (see Figures 4 and 5), sometimes referred to as full flow systems. This arrangement eliminates temperature mixing associated with primary-secondary piping, thereby delivering the lowest temperature water directly to the boiler return connections and optimizing thermal efficiency potential of the condensing boiler plant.

Adhere to the following for variable primary piping arrangements:

- Select secondary (system) pump(s) with sufficient total dynamic head for the pressure drop of the loop at design flow. See Figure 3 for the boiler water pressure drop. This boiler will automatically perform a safe shutdown in the event of a low flow condition; however, proper design flow is required to deliver heat to the users and prevent nuisance lockouts.



WARNING

All information in this manual is for reference and guidance purposes, and does not substitute for required professional training, conduct, and strict adherence to applicable jurisdictional/professional codes and regulations.

Ensure all labels on the boiler are legible. All connections and safety devices, both mechanical and electrical, must be kept clean, with ease of access for inspection, use and maintenance.

Do not store or use gasoline or other flammable vapors and liquids or corrosive materials in the vicinity of this or any other appliances.

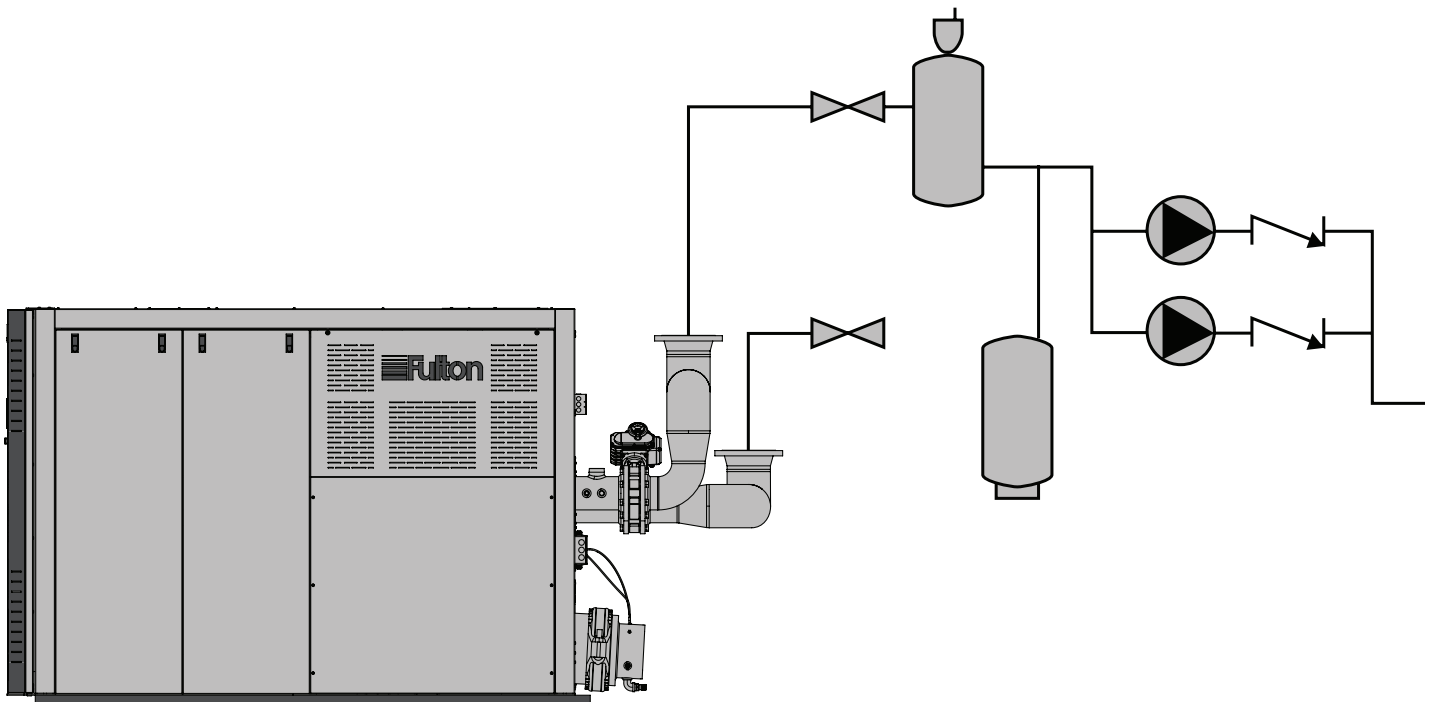

FIGURE 4 - SAMPLE PIPING LAYOUT, PRIMARY ONLY VARIABLE FLOW PIPING; SINGLE BOILER

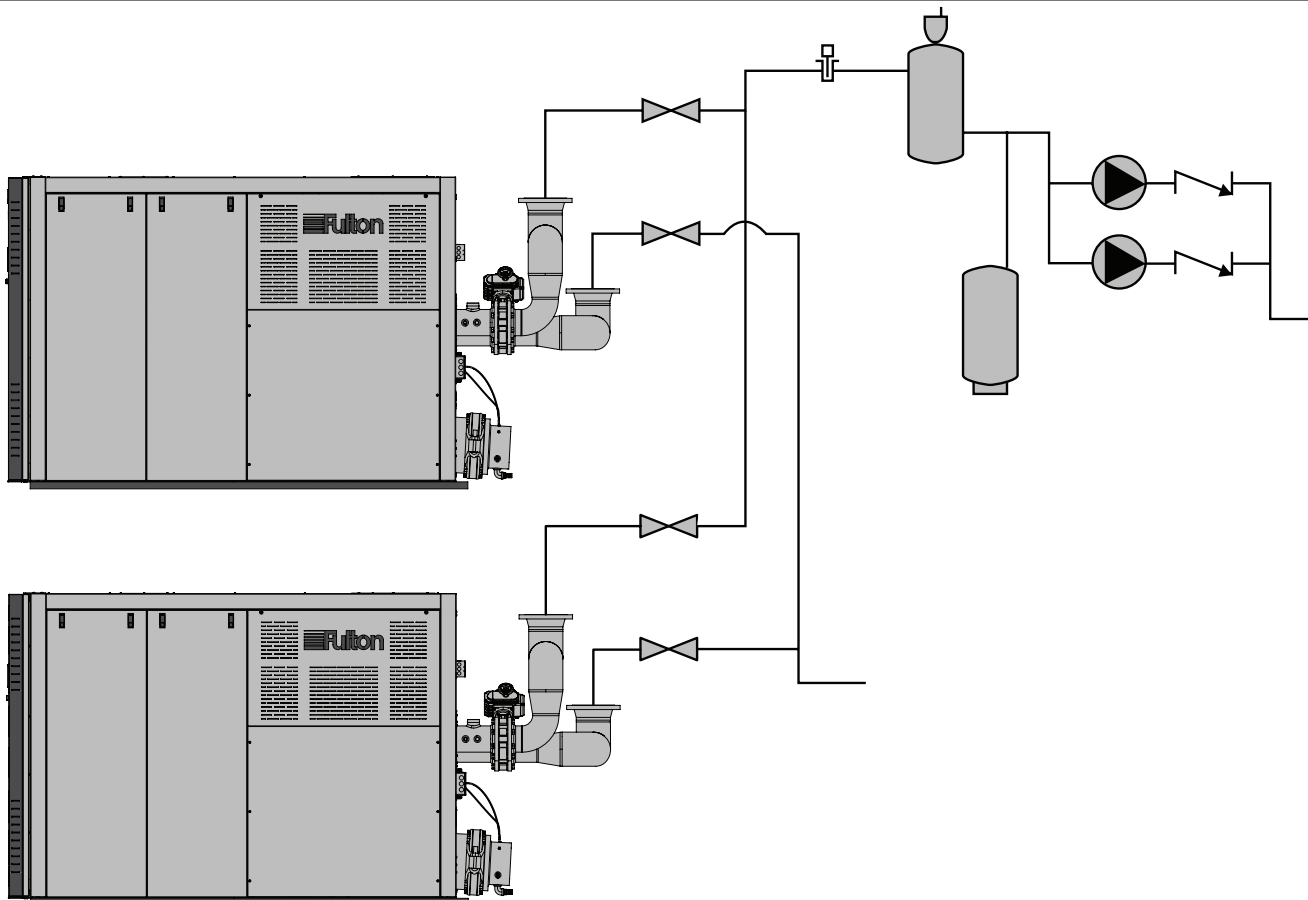

FIGURE 5 - SAMPLE PIPING LAYOUT, PRIMARY ONLY VARIABLE FLOW PIPING; MULTIPLE BOILERS

Note: Sample piping layout (P&ID) is a general representation of system installation. Good practice should be used in system design, including but not limited to adequate pipe/valve sizing and natural flow path for system water.

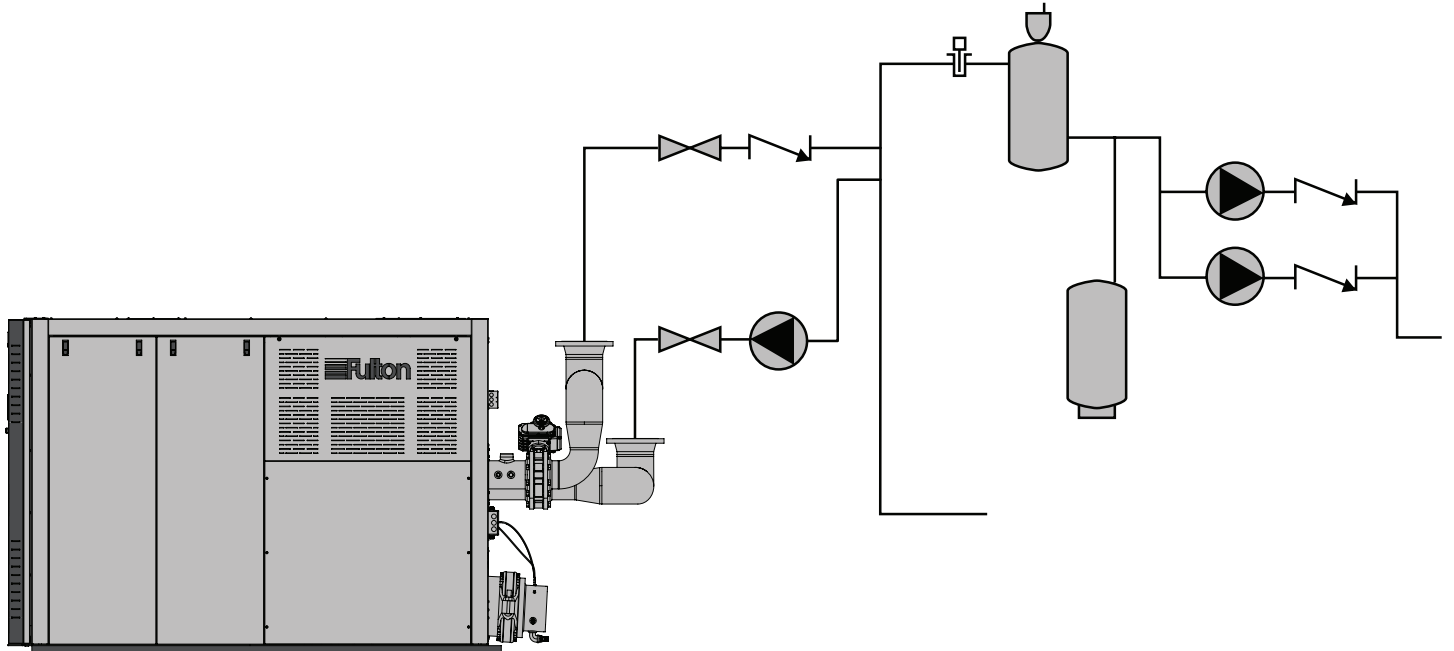

FIGURE 6 - SAMPLE PIPING LAYOUT, PRIMARY - SECONDARY PIPING; SINGLE BOILER

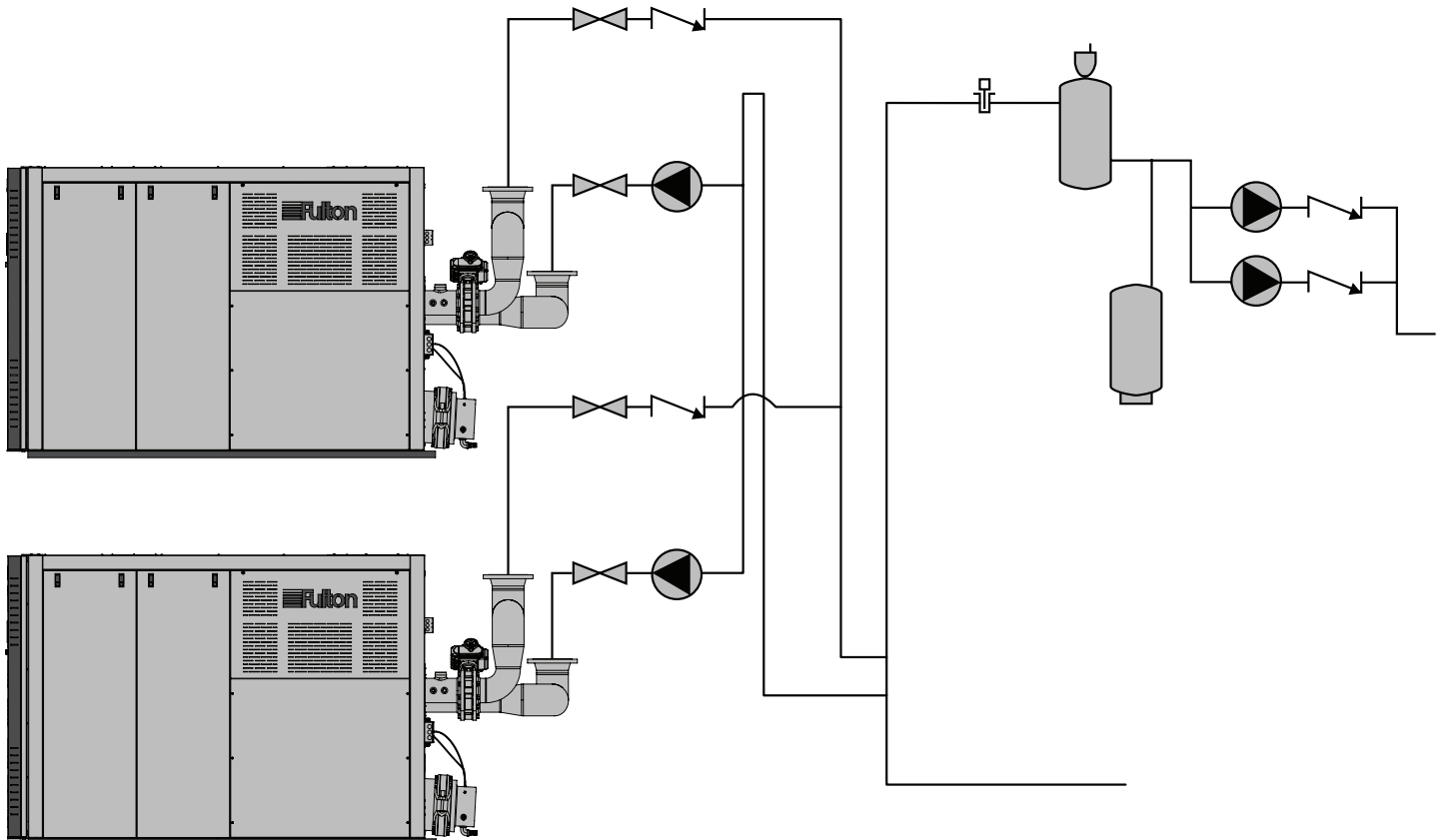

FIGURE 7 - SAMPLE PIPING LAYOUT, PRIMARY - SECONDARY PIPING; MULTIPLE BOILERS

Note: Sample piping layout (P&ID) is a general representation of system installation. Good practice should be used in system design, including but not limited to adequate pipe/valve sizing and natural flow path for system water.

WARNING

All information in this manual is for reference and guidance purposes, and does not substitute for required professional training, conduct, and strict adherence to applicable jurisdictional/professional codes and regulations.

Do not use matches, candles, flame or other sources of ignition to check for gas leaks.

CAUTION

Ensure process fluid (water) side of the boiler remains above of 32°F (0°C) while in storage or operation.

- A motorized isolation valve is factory wired per heat engine. This eliminates flow through idle boilers in accordance with ASHRAE 90.1-2013 (6.5.4.3.2). Blending of unheated supply water impacts temperature control and can cause manual reset high temperature lockouts. Do not install motorized isolation valves on the boiler return piping. Do not install modulating valves on boiler piping.
- Ensure flow paths in the hydronic loop and residual heat in the pressure vessel is adequately dispersed for sufficient time after the burner is disabled. The valve control system must be capable of leaving the lead boiler valve open at all times.
- Use a reverse return header to balance flow across the boilers. Where reverse return cannot be used, it is recommended to install a balancing valve per boiler.
- Do not install three-way mixing valves or minimum temperature protection. This boiler does not have a minimum return water temperature requirement.
- Install system bypass valve(s) at or after the last coil(s), do not install bypass valves directly after the secondary (system) pump(s).

■ Primary-Secondary Piping Arrangement

It is acceptable to install this boiler in a primary-secondary arrangement, although this arrangement is not required. See Figures 6 and 7. Primary-secondary arrangements are used to decouple the water flow of the primary (boiler) loop from the secondary (system) loop. Blending occurs in the shared piping region.

Adhere to the following for primary-secondary piping arrangements:

- Typical decoupling methods include closely spaced tees, a buffer tank, or a hydraulic separator. Where using closely spaced tees, separate by four pipe diameters or less.
- Install the dedicated boiler circulator on the inlet side of the boiler, pumping into the return connection. Select pump(s) with sufficient total dynamic head for the pressure drop of the loop at design flow. See Figure 3 for the boiler water pressure drop.

In addition to the above, adhere to the following for multiple boiler systems:

- A check valve is required per boiler. Motorized isolation valves are not an acceptable substitute for check valves
- Use a single common supply connection and a single common return connection into the secondary (system) piping. Do not use separate connections for each boiler into the secondary piping.
- Use a reverse return primary header to properly balance flow across the boilers. Where reverse return cannot be used, it is recommended to install a balancing valve per boiler.

Meet Water Chemistry Requirements

System water chemistry requirements are as follows:

- pH: Range of 8.5 - 10.5
- Oxygen: Less than 250 ppb (operating condition)
- Total Iron/Copper: Less than 5 ppm
- Corrosion Inhibitor: Capable of maintaining iron corrosion rates <2 mpy. Due to changing environmental restrictions, a non-heavy metal ALL ORGANIC inhibitor is recommended which is designed for multi-metal systems including ferrous metals and yellow metals such as copper and brass.
- Chloride: Less than 200 ppm
- Hardness: Less than 3.5 grains per gallon (60 ppm) in make-up/fill water. Calcium buildup on heating surfaces is not covered under warranty.

Adhere to the following:

1. Refer to your water conditioning or chemical treatment supplier for analysis and recommendations for proper system conditions.
 2. Follow a program with appropriate monitoring and maintenance of system water conditions as provided by your water conditioning or chemical treatment supplier.
 3. If RO/DI water is used as a source for hydronic loop water or makeup water, it must be neutralized to a pH of 8.5 - 10.5 prior to entering the boiler. Failure to neutralize the RO/DI water will void the pressure vessel warranty and may cause high general corrosion rates.
 - The system must have an automatic pH controller to monitor and log the levels. This must be independent of other chemical feed systems.
 - Makeup water pH range must be 7.5 - 8.8; the boiler water must be maintained within pH range of 8.5 - 10.5.
 4. Operate the boiler in a pressurized closed-loop system using water or water/glycol solution. A large amount of improperly treated make-up water can cause premature failure of the heat exchanger resulting from scale build up. Scale build up will reduce the efficiency and useful life of the boiler and is not covered under warranty.
 5. For freeze protection, an inhibited propylene glycol is recommended. The maximum concentration is 50% glycol by volume. Only use mixtures formulated for hydronic systems. DOWFROST™ HD is recommended. Do not use automotive glycol.
- **NOTE:** For systems using up to 50% glycol, a minimum of 30 psi is required at the boiler outlet.
6. At a minimum, the hydronic fluid should be checked for glycol concentration and pH once a year, or per glycol manufacturer schedule. A refractometer is recommended.

WARNING

All information in this manual is for reference and guidance purposes, and does not substitute for required professional training, conduct, and strict adherence to applicable jurisdictional/professional codes and regulations.

If the water supply must be temporarily disconnected from the condensate drain trap, the boilers must be turned off to prevent accidental flue gas emission into the boiler room.

CAUTION

Some soap used for leak testing is corrosive to certain types of metals. Clean all piping thoroughly after completing the leak check.

Care needs to be taken to eliminate oxygen from the water system, as excess oxygen in the system will reduce the life of any boiler. The boiler warranty does not cover heat exchanger replacement due to oxygen contamination of boiler water.

Heat exchanger failure due to inappropriate water quality, foreign matter or debris damage is not covered under the warranty.

If the piping system attached to this unit will be chemically cleaned, the boiler must be disconnected from the system and a bypass installed so that the chemical cleaning solution does not circulate through the boiler. If cleaning is desired, flush the boiler with clean domestic water only.

■ Prevent Oxygen Contamination

There are several ways to prevent boiler water oxygen contamination:

- Minimize system leaks to minimize make up water requirement
- Do not use open tanks or fittings
- Do not use oxygen permeable materials anywhere in the water system
- Repair leaks in the system quickly
- Eliminate fittings wherever possible
- Use air elimination devices in system piping

■ Eliminate System Air

► *NOTE: No built-in boiler air eliminating features exist.*

Adhere to the following for air elimination:

1. The installation of an air separator and air eliminator (air vent) is required.
2. If a sealed diaphragm-type expansion tank is used, install an air eliminator in the hot water piping at the air separator on the suction side of the system circulator(s).
3. If an air cushion type expansion tank is used, pipe tank directly into boiler supply on the suction side of the system circulator(s).
4. On multi-zoned systems (or a system with both space and domestic water heating), air elimination must be provided either in the common piping or on every loop.
5. When the boiler is installed at a higher level than heating coils (e.g., a penthouse boiler room), air elimination must be provided directly above the boiler.

Fill the Boiler with Water

To be sure that the boiler is not air-bound, open the pressure-relief valve located at the rear of the boiler. Leave the relief valve open until a steady flow of water is observed. Close the valve and finish filling the system.

Gas Supply Piping

This boiler features a gas fired fully modulating burner requiring delivery of gas at a relatively constant pressure and calorific content. This ensures efficient and reliable combustion.

The gas train (see Figure 8) pressure requirements are detailed in Table 1 and on the boiler name plate located at the rear of the boiler. Do not modify the factory gas train.

► *NOTE: Alternate or custom configurations may have different requirements; always review the boiler nameplate before installation.*

This boiler is factory test fired and combustion is adjusted per the factory test fire report.

■ Inlet Gas Pressure

Adhere to the following:

- *Static inlet gas pressure:* Measure while boiler is idle. Verify pressure is within allowable range.
- *Dynamic inlet gas pressure:* Measure while boiler is in operation at maximum firing rate. Verify pressure is within allowable range.
- The gas delivery system must provide a stable and consistent pressure across the entire turndown range, including light off and idle conditions.
- Maximum inlet gas pressure drop from static to dynamic must not exceed 15%, or the maximum allowable by local code (CSA B149 clause 6.3.2 for Canada). The stricter of the two shall apply.

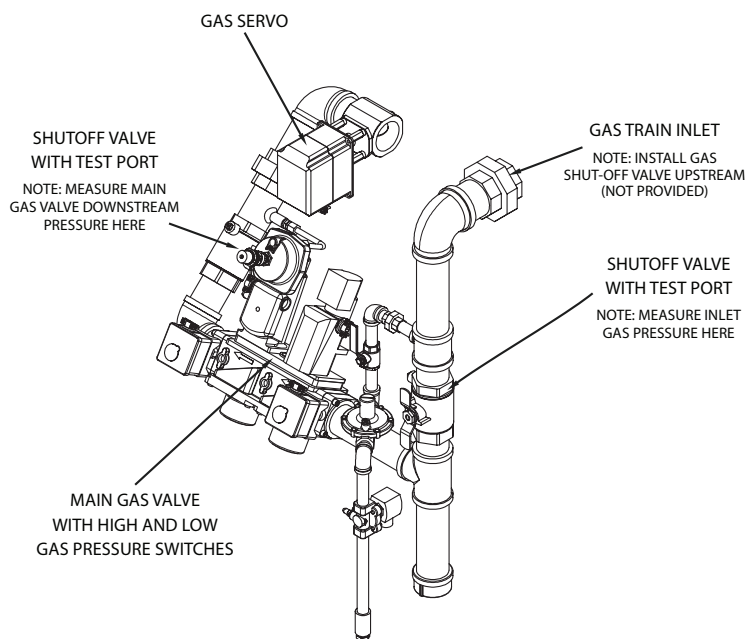

FIGURE 8 - TYPICAL GAS TRAIN PER MODULE
(VARIES BY SIZE/MODEL)

Line Gas Pressure Regulation

When inlet gas pressure exceeds the maximum on the boiler name plate, a line gas pressure regulator is required to step the gas pressure down to an acceptable pressure. See Figure 9.

Proper selection and installation of a gas pressure regulator is essential in providing conditions for efficient and reliable combustion. Adhere to the following guidelines when selecting and installing a gas pressure regulator:

- A line pressure regulator listed and labeled to ANSI Z21.80/CSA 6.22 is recommended. Lock-up is defined as an outlet pressure not more than 150% or 5" W.C., whichever is greater, above the setpoint after a downstream safety shutoff valve closes within 2 seconds. Appliance regulators are not a substitution for line gas pressure regulators and must not be used.
- A gas pressure relief valve may be required for overpressure protection, refer to the local code(s) adopted by the AHJ.
- A sediment trap is recommended prior to the inlet of the regulator.
- If the level of pipe system cleanliness is unacceptable or unknown, install a gas filter prior to the regulator.
- On the outlet of the regulator: Install a straight and uninterrupted section of pipe matching regulator connection size with a minimum length of 10 pipe diameters prior to any valves or fittings.
- When installed in close proximity to an appliance, some regulators may experience oscillation (hunting) or an outlet pressure spike when demand ends. Provide adequate volume by locating the regulator

a recommended minimum of 10 total linear feet of pipe from boiler fuel train inlet. Consult the regulator manufacturer for installation requirements.

- The body size should never be larger than the pipe size. However, a properly sized regulator may be smaller than the pipeline.
- The inlet pressure used for sizing should be measured directly at the regulator inlet. Measurements taken at any other point may be subject to losses associated with upstream piping.
- Consult the regulator manufacturer for orifice selection.
- If two or more springs are available for a particular outlet pressure in the desired range use the spring with the lower range for better accuracy.

Gas Piping Installation

Field gas piping must be installed in accordance with NFPA 54 National Fuel Gas Code, ANSI Z223.1, and any other local codes which may apply.

Adhere to the following for gas piping installation:

1. See Table 3 for required natural gas pipe size, based on overall length of pipe from the meter plus equivalent length of all fittings. Approximate sizing may be based on 1,020 BTU for 1 cubic foot of natural gas. See Figures 6 and 7 for piping arrangements.
2. Piping must be of the proper size to ensure adequate gas supply. It is typical for gas delivery piping to be upsized one or several diameters larger than boiler gas inlet size.

TABLE 3 - SCH 40 PIPE NATURAL GAS CAPACITY

Nominal Pipe Size	ID	Equivalent Pipe Length		Max Capacity in ft ³ of natural gas per hour at 14" WC pressure. Pressure drop of 0.5" WC. Equivalent length of pipe (feet)						
		90 Elb Feet (meter)	Tee Feet (meter)	20	40	60	80	100	150	200
1-1/4 (31.75)	1.380 (35.05)	3.45 (1.05)	6.9 (2.10)	950	-----	-----	-----	-----	-----	-----
1-1/2 (38.1)	1.610 (40.89)	4.02 (1.22)	8.04 (2.45)	1460	990	810	-----	-----	-----	-----
2 (50.8)	2.067 (52.50)	5.17 (1.57)	10.3 (3.13)	2750	1900	1520	1300	1150	950	800
2-1/2 (63.5)	2.469 (62.71)	6.16 (1.87)	12.3 (3.74)	4350	3000	2400	2050	1850	1500	1280
3 (76.2)	3.068 (77.92)	7.67 (2.33)	15.3 (4.66)	7700	5300	4300	3700	3250	2650	2280
4 (101.6)	4.026 (102.26)	10.10 (3.07)	20.2 (6.15)	15800	10900	8800	7500	6700	5500	4600
6 (152.4)	6.07 (154.17)	10.10 (3.07)	23.60 (7.19)	-----	-----	-----	-----	20220	16503	12766
8 (203.2)	7.98 (202.69)	13.30 (4.05)	29.10 (8.86)	-----	-----	-----	-----	41200	33660	29128

3. The pipe and the fittings used must be new and free of dirt or other deposits.
4. When making gas-piping joints, use a sealing compound resistant to the fuel gas serving the boiler.
5. Install a manual gas shutoff valve (not supplied) prior to the boiler.
6. Piping must be installed such that no piping stresses are transmitted to the boiler. The boiler cannot be used as a pipe anchor.
7. All gas piping connections must be pressure-tested and checked for leaks before being placed into service. Test with compressed air or inert gas if possible.
8. The boiler gas train must be disconnected at the boiler manual shutoff valve from the gas supply piping system during any pressure testing of the system at pressures in excess of 2.0 psig (55 inch W.C.).
9. After completing pressure testing and obtaining any necessary approvals from the AHJ, introduce gas service and purge gas piping in accordance with local codes.

Do not purge their contents into a confined space or where fuel gas can accumulate

10. The boiler gas train has been factory leak tested, however, fittings may loosen during shipment or installation. After gas piping is completed and before wiring installation is started, all piping connections (factory and field) must be carefully checked for gas leaks. Use a soap and water solution or combustible gas detector. A GAS-Mate® 0119 or equivalent is recommended.

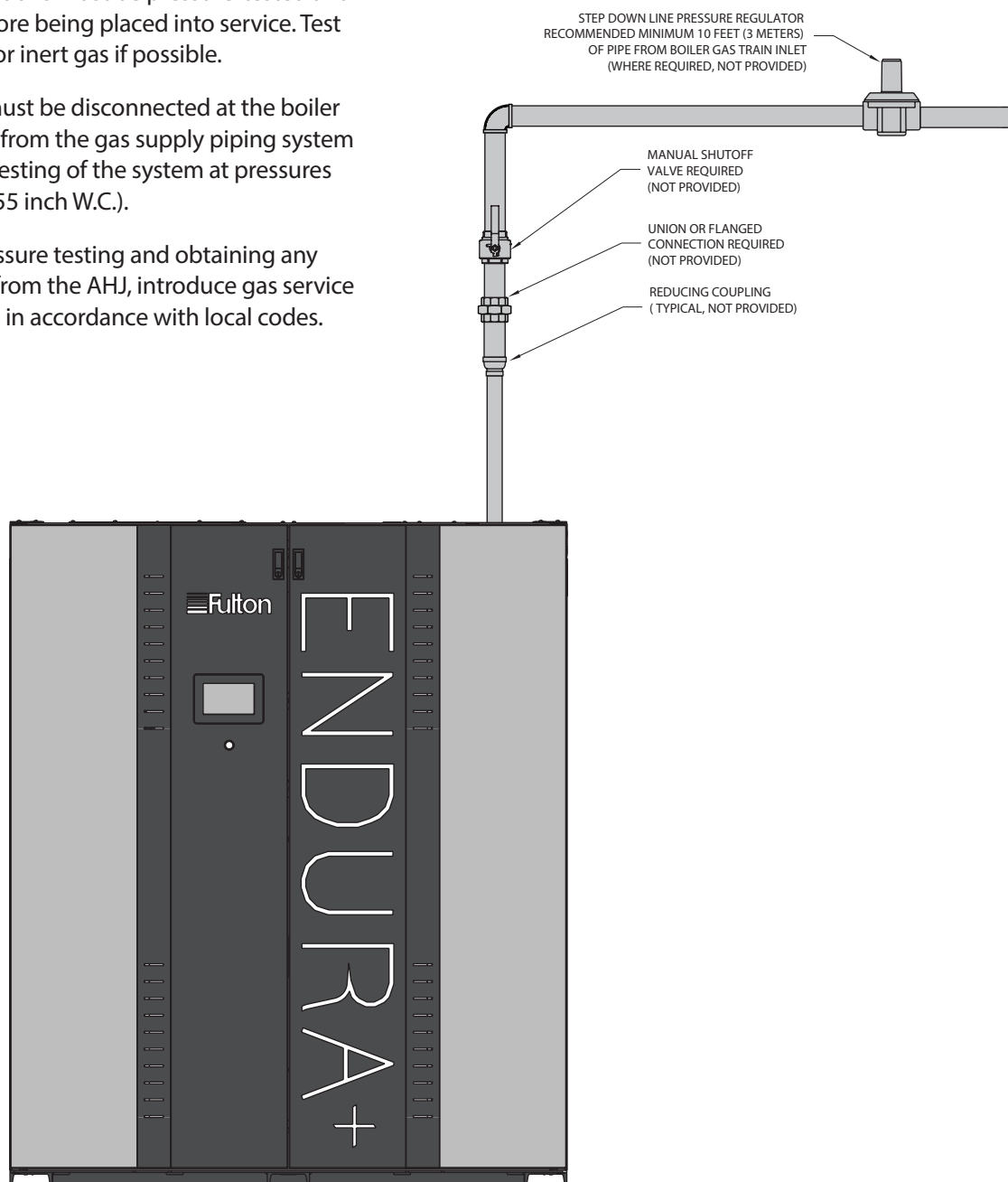

FIGURE 9 - FIELD GAS SUPPLY PIPING

■ Multiple Boiler Installation

When gas supply pressure exceeds the maximum on the boiler name plate, a line gas pressure regulator is required. It is recommended that an individual regulator be used at each boiler.

When a single regulator is used for multiple boilers, the regulator must be appropriate for the entire gas delivery flow (CFH) turndown range. This includes all boilers on at full fire to one boiler on at low fire.

■ Components Requiring Ventilation to the Outdoors

► *NOTE: The port marked "AIR" on the SKP25 actuator cannot be used as a gas vent connection. Connecting a vent line to this port may cause operational issues.*

The following do not require ventilation to the outdoors, as there is a vent limiter in use:

- Regulator on the pilot line.

An authority having jurisdiction (AHJ) may not permit the use of a vent limiter on some or all components. If venting is required, use the following general guidelines:

- Drill an appropriately sized penetration for each vent line of the boiler cabinet. Do not install any vent lines through removable latching panels. Properly seal around the pipe with sensor safe silicone.
- Each component must have a separate vent line to the outdoors. Vent lines must not be manifolded or combined with any other vent or exhaust systems.
- Start with the vent connection size and as soon as it is practical, increase the pipe size one diameter. For every ten feet of vent, increase the pipe size one diameter. Never reduce the vent size.
- Protect the vent termination from debris, dust and insects. Install the vent termination above the snow line and point down to prevent ingress of water. The termination must be a minimum of 3 ft (0.9 m) from a source of ignition.



WARNING

All information in this manual is for reference and guidance purposes, and does not substitute for required professional training, conduct, and strict adherence to applicable jurisdictional/professional codes and regulations.

WARNING

All information in this manual is for reference and guidance purposes, and does not substitute for required professional training, conduct, and strict adherence to applicable jurisdictional/professional codes and regulations.

CAUTION

An uninterruptible water supply is required for the multiple boiler condensate trap and shall be connected to the ¼" (U.S. only) compression fitting. The water supply maintains a water level in the drain kit to prevent accidental flue gas emission into the boiler room.

Install Condensate Drain Trap

A condensate drain trap is intended for use with the Fulton Endura+ boiler.

The boiler condensate drain trap is Fulton Part Number 4-57-000440. The maximum capacity to attach per condensate drain trap is 12 MMBH total. (See Figures 10 and 11).

Adhere to the following for installation:

1. A flexible condensate drain hose must be installed between the boiler and any piping anchored to the floor. Ensure there are no low spots.
2. The Fulton Endura+ boiler 1 inch (25.4 mm) condensate drain outlets will be connected to the 1 inch (25.4 mm) inlet on the drain trap. Use a common header pipe at floor level.
3. If the water supply must be temporarily disconnected, the boilers must be turned off to prevent accidental flue gas emission into the boiler room.
4. The condensate drain cover must be kept on at all times, except during maintenance of the drain. This drain should be checked regularly in your boiler maintenance schedule.
5. A condensate collecting tank and condensate pump will be required if a floor drain is not available to collect condensate (collecting tank and pump are not supplied with the boiler.)
6. All piping (Figure 10) must be CPVC, high-temperature silicone tubing, galvanized, or stainless steel, and be free of leaks. Copper, carbon steel/iron pipe or PVC are not acceptable.
7. Connect 1 inch (25.4 mm) condensate drain(s) (at the rear of the boiler), to the 1 inch (25.4 mm) inlet at the base of the drain tank. The header must be below the condensate outlet of the individual boiler, and must remain flooded during operation.
8. Connect the 1.5 inch (38.1 mm) drain outlet to an appropriate waste line following applicable codes. The 1.5 inch (38.1 mm) drain connection on the drain tank must be the highest point prior to going to the drain. Failure to keep drain piping lower than this point will result in overflow of the drain tank. Slope the drain pipe away at a minimum pitch of 1 inch (25.4 mm) for every 12 feet (3.65 m).
9. Attach a ¼" water supply to the compression fitting on the float. The water line must be connected to an uninterruptible supply. Install before the "fast fill" valve to the boiler supply—but after the back flow preventer—to avoid contamination of a potable water supply. Maximum allowable water pressure to the compression fitting is 100 PSI (689.5 kPa).
10. Ensure condensate drain piping will not be exposed to freezing temperatures.

Figure Notes:

1. Header must be slightly pitched toward the drain.
2. Header material must be CPVC, high-temperature silicone tubing, galvanized steel, or stainless steel.
3. Header should be taken to the lowest point possible and remain flooded during operation.
4. The condensate drain trap outlet must be below the condensate outlet of the boiler.
5. Maintain minimum pipe size of one inch (25.4 mm) for the header piping.
6. The maximum capacity of the boiler condensate drain trap is 12 MMBH total.
7. Housekeeping pad required, minimum 4" (102 mm).

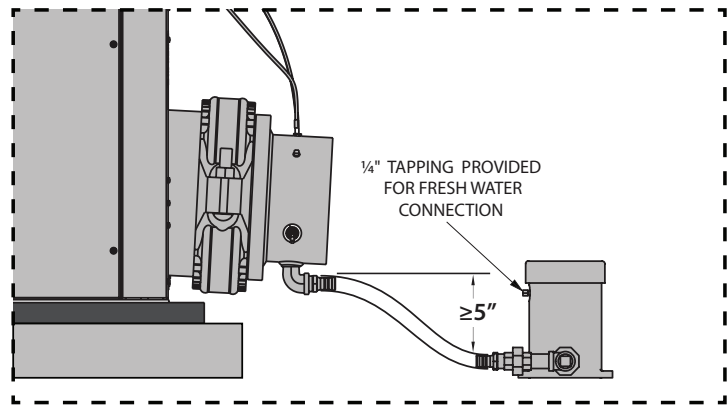
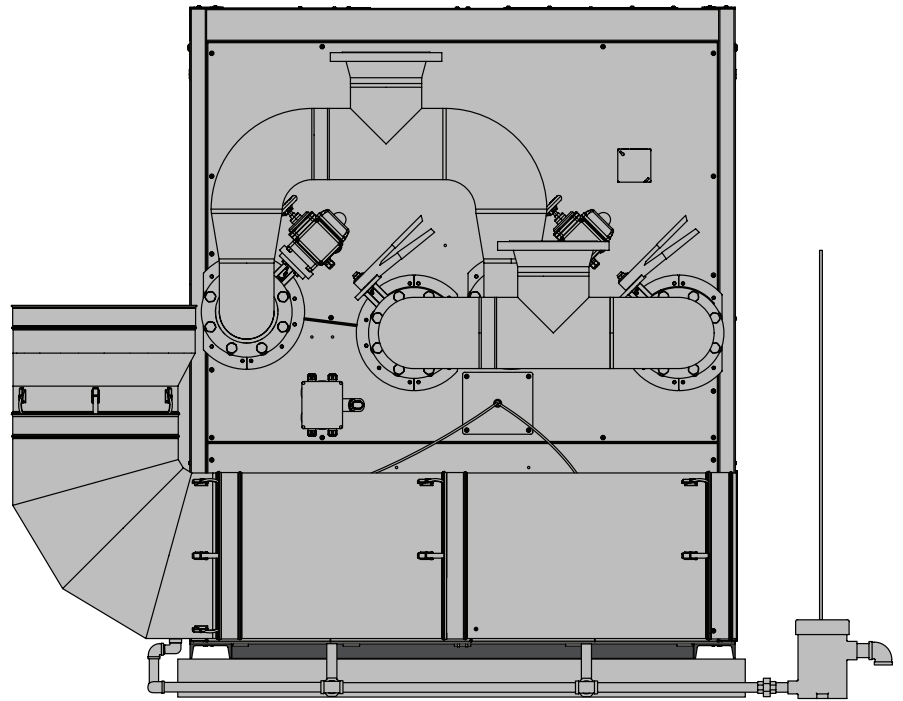

SIDE VIEW

FIGURE 10 - CONDENSATE DRAIN PIPING

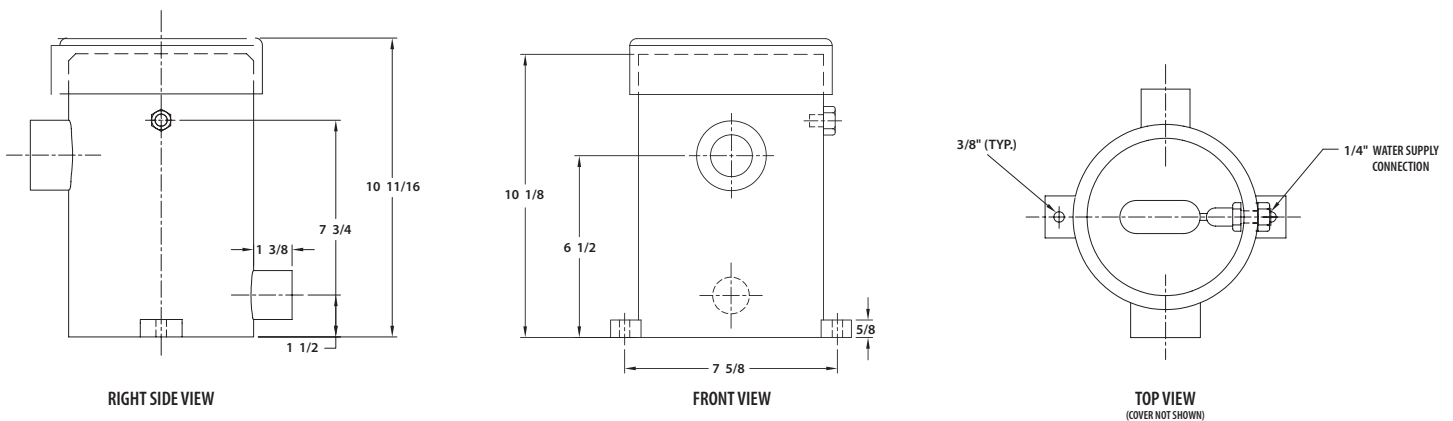

FIGURE 11 - MULTIPLE BOILER CONDENSATE DRAIN TRAP

Install pH Neutralization Kit

The pH Neutralization Kit uses a consumable medium to bring the pH level of the boiler's condensate to a more neutral level. It is not a replacement or alternative for the Condensate Drain Trap. See Figures 12 and 13.

Adhere to the following for pH Kit installation:

1. Use CPVC, high-temperature silicone tubing, stainless, or galvanized pipe and fittings to connect condensate trap to kit.
2. Connect kit downstream of Condensate Drain Trap. See Figure 14.

3. Pipe outlet to appropriate drain. It is acceptable to use PVC or CPVC on the outlet to drain.
4. Check condensate pH periodically.

► **NOTE:** Replacement bags are available from your Fulton local representative. The medium in the container will neutralize the condensate of 12 MMBH for approximately 6 months. (Fulton Part No. [2-30-001580](#))

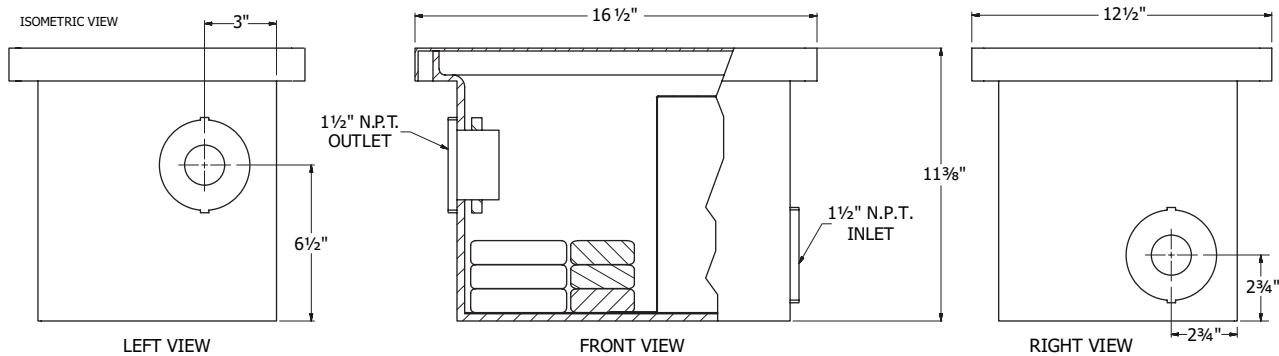
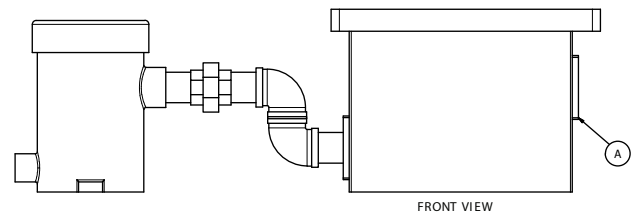
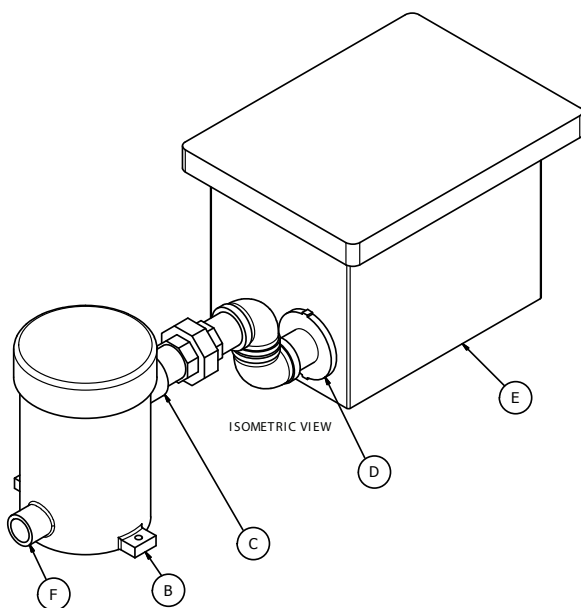

FIGURE 12 - FULTON PH NEUTRALIZING KIT



	Multiple Boilers
(A) pH Kit Outlet	1 1/2"
(B) Condensate Drain Trap	4-57-000440
(C) Drain Outlet	1 1/2"
(D) pH Kit Inlet	1 1/2"
(E) pH Neutralization Kit	4-50-000008
(F) Drain Inlet	1"
Neutralizing Media	2-30-001580

FIGURE 13 - FIELD CONNECTIONS FOR CONDENSATE DRAIN TRAP TO PH NEUTRALIZATION TANK

Venting Requirements

Adhere to the following venting requirements:

1. This boiler can operate to the combined intake and flue exhaust pressure drops without altering standard capacities: See Table 4.
 2. The combined venting system draft pressure readings at the boiler exhaust connection and air intake connection cannot exceed the maximum values stated in Table 4; and must remain relatively stable throughout all operating conditions, including the ignition sequence.
- *NOTE: Venting pressure is the combined result of frictional pressure drop and natural draft (stack effect) in the combustion air intake piping (if used) and flue gas exhaust system.*
3. Drastic draft changes during operation may result in the generation of excessive carbon monoxide or soot, which may affect operational reliability and condition of burner, ignition assembly, or other combustion system components leading to increased maintenance or replacement of these items.
 4. The equivalent length method is not a substitute for good engineering practice for determining acceptability of a vent system due to varying burner modulation rates, ambient air temperatures, and flue gas temperatures, among other factors. Combustion air intake piping (if used) must be accounted for in an analysis of the venting system.
 5. If the maximum positive pressure loss is exceeded, the boiler may have to be de-rated or require the installation of draft accessories such as an engineered exhaust assist fan to prevent operational issues from occurring. If the maximum negative pressure is exceeded due to excessive natural draft (stack effect), the exhaust system may require the use of draft accessories such as a fixed-position balancing baffle or modulating overdraft damper. Draft accessories must be appropriate for Category II/IV installations and are not included with the boiler. Consult your venting supplier for recommendations.
 6. Where modulating overdraft dampers are used, individually vent each heat engine in place of the factory exhaust manifold kit, and use one damper per heat engine. Each damper must receive its enable signal from the respective heat engine combustion blower (fan) enable circuit.
 7. Adhere to local and jurisdictional codes and regulations, which may differ from recommendations and diagrams contained in this manual.
 8. Site specific conditions not addressed in this manual may require additional precautions or design considerations. Consult your local Fulton Representative and venting supplier for recommendations.
- *NOTE: Consult your venting pipe supplier for assistance with sizing of vent materials and other potentially required accessories.*
9. The layout of the piping used for air intake and exhaust must be done in a way that facilitates smooth travel and natural flow.



WARNING

All information in this manual is for reference and guidance purposes, and does not substitute for required professional training, conduct, and strict adherence to applicable jurisdictional/professional codes and regulations.



CAUTION

An uninterrupted water supply is required for the multiple boiler condensate trap and shall be connected to the ¼" (U.S. only) compression fitting. The water supply maintains a water level in the drain kit to prevent accidental flue gas emission into the boiler room.

WARNING

Do not terminate venting into an enclosed area.

Never use open flame or smoke from a cigarette, cigar, or pipe as a testing method during boiler installation, operation, or maintenance.

Foreign substances, such as combustible volatiles in the combustion system can create hazardous conditions. If foreign substances can enter the air stream, the boiler combustion air inlet must be piped to an outside location.

10. A pressure drop calculation is an acceptable method for evaluating theoretical draft, but is not enough information to fully validate combustion air intake and flue gas exhaust vent systems. The designer and installer must use good practice and remain cognizant of important factors that cannot be captured by a pressure drop calculation such as local code requirements, accessibility for inspection and maintenance, aesthetic concerns, flue gas recirculation, stagnant vapor plumes, prevailing wind direction, nearby mechanical equipment and other design considerations as detailed in this manual. Some recommendations:
 - Avoid sharp turns, boot tees, bullhead tees, back-to-back 90 degree elbows, short radius elbows.
 - Avoid extensive direction changes (flue gases being required to turn around).
 - Never direct flue stacks in a downward direction.

TABLE 4 - GENERAL VENTING PRESSURE REQUIREMENTS

Endura+ Model Number	Maximum Negative Draft	Maximum Combined Pressure Loss
EDR+8000	-0.10" W.C.	+1.00" W.C.
EDR+10000	-0.10" W.C.	+1.00" W.C.
EDR+12000	-0.10" W.C.	+1.00" W.C.

Combustion Air Intake

Adhere to the following for installation:

1. It is the responsibility of the designer and installer of the venting system to guarantee the prevention of flue gas recirculation (flue gases being drawn into a boiler's combustion air supply, or flue gases moving backward through an idle boiler).
2. The installation of room exhaust fans in a boiler room should be avoided. A boiler room exhaust fan or similar equipment can create down draft in the stack or restrict the burner's air supply which will result in poor combustion or life safety hazard.
3. It is essential that only fresh air is allowed to enter the combustion air system. Foreign substances, such as combustible volatiles in the combustion system can create hazardous conditions.
4. Particulate matter or chemicals (example: chlorine, sulfur, freon, fluorine, perchlorethylene, halogenated compounds) in the combustion air supply to the boiler will cause damage or failure to the heat exchanger and/or burner and is not covered under warranty. High-risk situations for particulate matter to be in the air include construction and maintenance activities. See Table 5.

► *NOTE: Pool and laundry room air may be contaminated with chlorine or fluorine compounds. If allowed to enter the combustion air supply, these contaminants will significantly increase the acidity of flue gas condensate, potentially damaging heat transfer surfaces. Damage to the heat exchanger due to poor combustion air quality is not covered under warranty.*

TABLE 5 - PRODUCTS/CONTAMINANTS TO AVOID

Products to avoid	Products containing chloro/flouorocarbons; chlorine-based products; calcium chloride products, sodium chloride products, paint and varnish removers, hydrochloric acid, muriatic acid, cements, glues, antistatic fabric softeners, Freon, drywall particles, dirt, fiberglass.
Areas with the potential to have contaminants	Dry cleaning/laundry areas; swimming pools; repair shops; processing plants; manufacturing plants, active construction sites; chemical storage; food processing plants; farms; chillers; cooling towers.

5. Ensure there is not a negative pressure in the boiler room. The boiler room pressure must be neutral relative to the outdoors.

■ Combustion Air Supply From the Boiler Room

Adhere to the following for installation:

1. Adequate combustion air and ventilation must be supplied to the boiler room in accordance with local codes and NFPA54/ANSI Z233.1, Section 9.3, Air for Combustion and Ventilation or CSA-B149.1 for Canada. The minimum net free area requirements in Table 6 may not supersede local and jurisdictional codes and regulations where there codes and regulations require an opening of greater net free area. The boiler room must meet the NFPA criteria for a non-confined space. See Figure 16.
2. Verify combustion air is taken from the outdoors and not from the inhabited or occupied spaces within the building. Ensure space and nearby products are evaluated for the potential of combustion air contaminants. See Table 5.
3. For installations providing two permanent openings directly communicating with the outdoors, the minimum net free area of each opening is 1 in² per 4,000 BTU/hr of the total input capacity of the combined burners located in the boiler room. A high opening and a low opening is required. Ensure the high opening commences within 12 inches of the ceiling, and the low opening commences within 12 inches of the floor. See Table 6.
4. For installations providing a single permanent opening directly communicating with the outdoors, the minimum net free area of the opening is 1 in² per 3,000 BTU/hr of the total input capacity of the combined burners located in the boiler room. See Table 6.

TABLE 6 - MAKE-UP AIR VENTILATION OPENINGS

Boiler Input Capacity (MBTU/HR)	Two Openings - Min. Net Free Area Each (SQFT)		Single Opening Only Min. Net Free Area (SQFT)
	Low	High	
8000	13.8	13.8	18.6
10000	17.6	17.6	23.2
12000	20.8	20.8	28.0

5. For multiple boiler installations, multiply the number of boilers by required net free area per boiler.

WARNING

All information in this manual is for reference and guidance purposes, and does not substitute for required professional training, conduct, and strict adherence to applicable jurisdictional/professional codes and regulations.

CAUTION

Oxygen sensors are susceptible to silicone poisoning, which can cause premature degradation. Use only "sensor safe" silicone around the boiler and on combustion air supply materials.

Should the boiler be operated during active construction, it is recommended to remove the Oxygen sensor and plug the port. The Oxygen sensor may be reinstalled after the combustion air quality is no longer potentially contaminated by construction particulates or chemicals.

WARNING

All information in this manual is for reference and guidance purposes, and does not substitute for required professional training, conduct, and strict adherence to applicable jurisdictional/professional codes and regulations.

CAUTION

Do not use insulation on polypropylene materials. Use of insulation may elevate pipe wall temperatures, resulting in the potential for vent material failure.

Ensure there is not negative pressure in the boiler room. The boiler room pressure must be neutral relative to the outdoors.

NOTE

Listing precludes direct vent witness test.

6. The net free area required for the boiler(s) is in addition to the combustion or ventilation air supply requirements of other equipment sharing the same space such as water heaters, generators, air compressors, or other boilers. The boiler room must have an opening or openings not less than the total net free area required for all types of equipment.
7. Consider the blocking effects of louvers, grills, and screens on the net free area of each opening. Ensure ventilation openings are unobstructed.
8. Where mechanical combustion air supply systems are used, such as a combustion air supply fan or a motorized louver, they must be interlocked with the boiler control panel to prove operation prior to burner ignition and during burner operation. Where manual louvers are used, ensure they are fully open prior to operating the boiler(s).

■ Combustion Air Ducted from the Outdoors

The combustion air supply may be ducted to the air inlet of the boiler.

Adhere to the following for installation:

1. An adapter kit (factory option) is required to connect the boiler air inlet to the combustion air piping. Use a rubber coupling to connect the air inlet adapter to the air intake piping.
 - *NOTE: The weight of combustion air intake piping must not be supported by the boiler. Ensure air intake piping is externally supported on hangers or straps.*
2. The boiler room must not contain contaminated air.
3. The combustion air intake termination must be located as to not be subjected to the intake/exhaust effects of other mechanical equipment such as other fuel fired heating equipment, loading docks, generators, air handling systems, and cooling towers.
4. Ensure the boiler room air is maintained at a dew point temperature below the temperature of combustion air. Failure to provide adequate ventilation or control dew point temperature may increase maintenance or damage boiler components.
5. The air intake system must be designed to prevent any moisture from draining to the boiler. Slope the air intake duct down away from the boiler. See Figures 15 and 17.
6. Air Intake pipes and fittings shall be Schedule 40 PVC pipe or smooth-walled galvanized steel. All Schedule 40 PVC pipe, fittings, primer and cement must conform to American National Standard Institute and the American Society for Testing and Materials (ANSI/ASTM standards) per pipe manufacturer's requirements.
7. Intake PVC piping must be assembled using cement. This will ensure that the intake is air tight and will not allow contaminants from the boiler room into the boiler. The cement must be free flowing and contain no lumps, undissolved particles or any foreign matter that adversely affects the joint strength or chemical resistance of the cement. The cement must not show gelation, stratification, or separation that cannot be removed by stirring.
8. Adhere to procedure for cementing joints (per ASTM D2855).
9. Avoid sidewall exhaust with roof-terminated intake air. This may lead to reverse stack effect when the boiler is idle.

Combustion Air Filter

The air filter requires monthly inspection and, at minimum, annual replacement. See **Maintenance** section of this manual.

Flue Gas Exhaust Venting

This boiler is equipped with vent connections at the lower rear of the boiler.

Adhere to National Fuel Gas Code (ANSI Z223.1) and the following for installation:

1. This boiler is a Category II/IV appliance, thus requiring Special Gas Vent material appropriate for condensing, positive pressure applications. Any venting material supplied for the Endura+ boiler must be AL29-4C or 316L/444 SS, listed and labeled to UL 1738, and guaranteed appropriate for the application by the manufacturer and supplier of the venting. It is also acceptable to vent the boiler as a Category II condensing, negative pressure, for which an upsized diameter is typically required.
2. Where allowed by the authority having jurisdiction (AHJ), the exhaust may be vented using polypropylene listed and labeled to UL 1738 or ULC S636. Do not insulate polypropylene exhaust vents.
3. Do not use boot tees or bullhead tees. Use inline condensate drains in place of boot tees at the bottom of a vertical rise.
4. Barometric dampers are physically open to the mechanical space. When used in a condensing boiler application with negative pressure (Category II) exhaust vent, the design must prevent flue gas condensate from draining down the outside of the stack or dripping into the space. For installation using a barometric damper, verify the air openings meet the requirements in Table 6, and a spill switch and a CO detector are installed and interlocked with the boiler(s). Barometric dampers must never be used in a positive pressure (Category IV) exhaust or a direct vent sealed combustion application.
5. The use of PVC/CPVC or Radel® (polyphenylsulfone) in venting systems is prohibited.
6. A flue adapter (not supplied) specific to vent manufacturer type and material may be required. Consult the venting supplier for guidance.
7. Adequate provision must be made to support the weight of the exhaust venting. It must not be supported by the boiler exhaust connection.
8. Follow the venting manufacturer's instructions for installation of flue gas venting.
9. Horizontal vents must allow for flue gas condensate to drain back to the boiler exhaust connection with a minimum pitch of ¼" (7 mm) per foot (300 mm) run. Failure to do so can create a condensate pocket, which can result in an inoperative boiler. There must be no low spots in the exhaust vent, as this can also result in a condensate pocket.
10. The boiler control will automatically disable and reset the burner should the flue gas temperature exceed the stack limit setting. The stack material parameter may be field adjusted (See **Operation**).



WARNING

Fulton accepts no liability for installation of any venting, including the selection of venting materials. Maximum allowable flue gas operating temperatures may vary by manufacturer. Consult the venting supplier for maximum allowable temperatures.

Barometric dampers must never be used in a positive pressure exhaust or direct vent sealed combustion application.



CAUTION

This boiler comes standard with a factory flue gas exhaust manifold kit. Where opting out of using the factory exhaust manifold kit, the heat engines must be vented individually or if manifolded the installation must include a minimum of 10 ft (3 m) of 14 in (356 mm) internal diameter flue gas vent before joining into a manifold.

WARNING

All information in this manual is for reference and guidance purposes, and does not substitute for required professional training, conduct, and strict adherence to applicable jurisdictional/professional codes and regulations.

CAUTION

Improper design or installation of a Category II common flue gas exhaust vent layout resulting in positive pressure in the common vent can result in flue gas and carbon monoxide spillage into the boiler room, causing property damage, personal injury, or death.

Do not use insulation on polypropylene materials. Use of insulation may elevate pipe wall temperatures, resulting in the potential for vent material failure.

Ensure there is not negative pressure in the boiler room. The boiler room pressure must be neutral relative to the outdoors.

11. If stack drains are installed, they must be properly pitched and combined with the boiler flue gas condensate drain piping into the condensate drain trap.

Common Flue Gas Venting Layouts

It is possible to combine the air intake and/or exhaust venting of multiple Endura+ boilers. The pressure drop across the entire common system, the combined total of both air intake and exhaust, must comply with the draft pressure requirements for an individual boiler, see Table 4.

Refer to Figure 14 and adhere to the following for installation:

1. Consult your venting supplier for guidance in designing common vented installations. The system must be thoroughly evaluated by a professional using accepted engineering practices to prevent backflow of exhaust gases through idle boilers.
2. This boiler is not approved for combined venting with other equipment such as steam boilers, water heaters, generators, and other types of equipment.
3. The AHJ may require the installation of a CO detector interlocked with the boiler(s), this is recommended best practice even where not required.
4. A constant diameter common header is recommended. Do not use the static regain method.
5. A minimum 1/4" rise per foot run is required for horizontal sections.
6. Where individual stacks transition into the common header, a 45 degree reducing tee or elbow in the direction of flow is recommended. Straight-in or 90 degree tees must not be used.
7. Precautions must be taken to ensure that the draft pressure at each boiler is maintained within in the required range (refer to Table 4) throughout all conditions while also maintaining a slight negative draft pressure in the common exhaust header. Consider all possible operating conditions of the exhaust system specific to the application, including:
 - Low and high flue gas temperatures
 - Low and high ambient air temperatures
 - All boilers operating at their maximum input rating capacity
 - One boiler in the system operating at the low fire position
 - No boilers on, pre-purge and ignition
8. Consider the natural draft effects associated with vertical exhaust vent rise. Over-draft control accessories, such as modulating stainless steel dampers, may be required to mitigate a negative pressure exceeding the value in Table 4. An undersized common exhaust vent or pressure drop due to horizontal run can create a positive pressure common exhaust situation which may require a mechanical draft assist (exhaust fan) system.

When designing a draft system for a quantity of two or more Endura+ boilers, the following items must be considered and addressed by the parties responsible for designing and providing that system:

Figure 14 Notes:

1. All installations must be in compliance with local and national codes. This is a typical arrangement for reference purposes only. Actual installations may require alternate or additional components which are not shown for clarity.
2. This drawing is not for construction purposes.
3. Adhere to clearance and installation requirements.
4. The common exhaust header should be maintained at a slight negative pressure within the requirements of the boiler. A positive pressure common header will require draft accessories to guarantee flue gases cannot travel backward through an idle boiler. A constant diameter common header is recommended. Do not use the static regain method.
5. A minimum 1/4" rise per foot run is required.
6. A 45° reducing tee or elbow in the direction of flow is recommended. Straight or 90° tees must not be used.
7. Do not use boot tees or bull head tees.
8. Endura+ boilers cannot be common vented with other equipment.

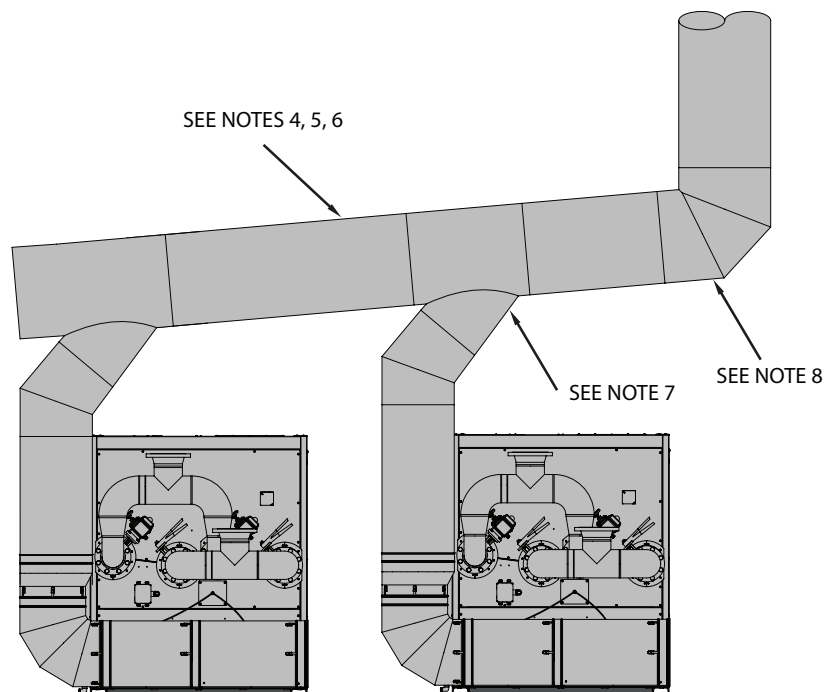

FIGURE 14 - TYPICAL COMMON FLUE GAS EXHAUST VENT LAYOUT

■ Common Venting Exhaust Backflow Prevention

1. When combining multiple exhaust vents, the system must be designed to guarantee flue gas exhaust will not backflow through an idle boiler. This requires appropriately sizing a Category II common exhaust vent to maintain a slight negative draft pressure of -0.01 to -0.10" W.C. throughout all operating conditions when one or more boilers are idle..
2. It is recommended to install individually piped intake vents or use neutral pressure boiler room air with a common exhaust system. For common exhaust vent applications also combining combustion air intake (CAI) ducts into a common duct, it is necessary to upsize the common CAI duct for a negligible pressure loss.
3. If the common exhaust configuration does not allow for a stable negative pressure under all operating conditions, a mechanical draft assist system, such as a variable speed exhaust fan, may be required.

WARNING

All information in this manual is for reference and guidance purposes, and does not substitute for required professional training, conduct, and strict adherence to applicable jurisdictional/professional codes and regulations.

CAUTION

Improper design or installation of a Category II common flue gas exhaust vent layout resulting in positive pressure in the common vent can result in flue gas and carbon monoxide spillage into the boiler room, causing property damage, personal injury, or death.

Do not use insulation on polypropylene materials. Use of insulation may elevate pipe wall temperatures, resulting in the potential for vent material failure.

Ensure there is not negative pressure in the boiler room. The boiler room pressure must be neutral relative to the outdoors.

Venting Terminations

Adhere to the National Fuel Gas Code (ANSI Z223.1) and the following for installation:

1. Do not terminate the venting in an enclosed area. Care must be taken when selecting the type and orientation of the terminations.
2. All vent pipes and fittings must be installed with appropriate air space clearances to combustibles. These air space clearances apply to indoor or outdoor vents—whether they are open, enclosed, horizontal or vertical or pass through floors, walls, roofs, or framed spaces (See Figures 15, 16, and 17). The air space clearances should be observed to joists, studs, sub floors, plywood, drywall or plaster enclosures, insulating sheathing, rafters, roofing, and any other material classed as combustible.
3. To prevent the possible re-circulation of flue gases, the vent designer must take into consideration such things as prevailing winds, eddy zones, building configurations, etc. Adverse conditions effect operation reliability and durability of the boiler(s).
4. The required minimum air space clearances also apply to electrical wires and any kind of building insulation.
5. Listed termination parts must be used.
6. Select the air intake point of penetration where a minimum of 1/4" per foot (6.35 mm per .3 m) upward pitch can be maintained.
7. It is recommended to install a mesh bird screen, with minimum 1/2" by 1/2" openings, at the combustion air intake termination. Climates subject to extreme cold may require alternate configurations to provide an increased surface area, such as cylindrical basket screens. Consult your venting supplier for recommendations.
8. It is important to locate the exhaust termination in such a way that it does not become blocked due to snow, ice, and other natural or man-made obstructions. If terminating into a prevailing wind, direct elbow upward. Avoid areas (example: courtyards) where swirling high winds may be present.
9. The use of rain caps on the flue termination is not recommended. Rains caps contribute to ice buildup, stagnant vapor plumes, flue gas recirculation (FGR), and additional vent pressure loss. See Figures 15 and 16.

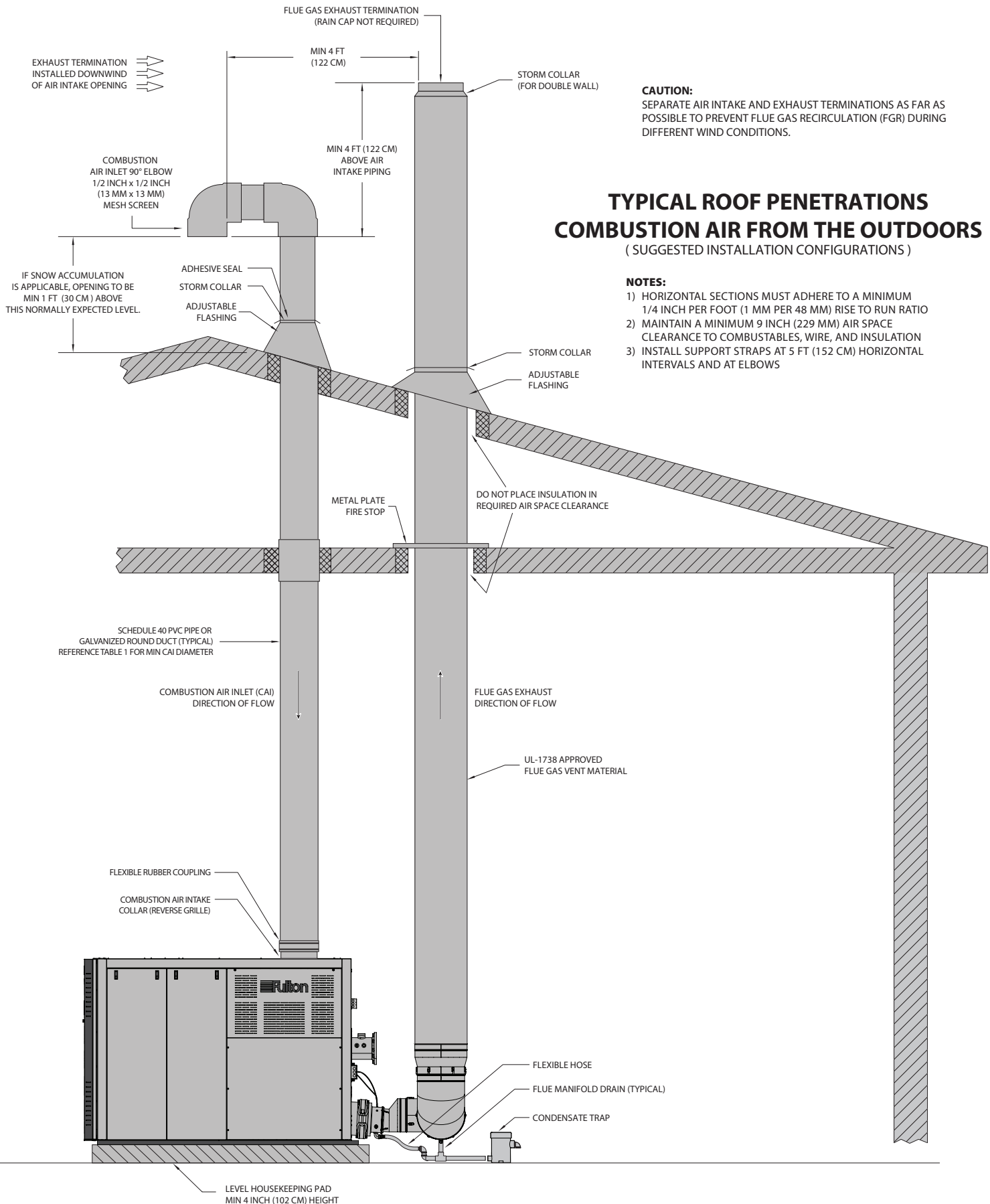

CAUTION:
SEPARATE AIR INTAKE AND EXHAUST TERMINATIONS AS FAR AS POSSIBLE TO PREVENT FLUE GAS RECIRCULATION (FGR) DURING DIFFERENT WIND CONDITIONS.

**TYPICAL ROOF PENETRATIONS
COMBUSTION AIR FROM THE OUTDOORS**
(SUGGESTED INSTALLATION CONFIGURATIONS)

- NOTES:**
- 1) HORIZONTAL SECTIONS MUST ADHERE TO A MINIMUM 1/4 INCH PER FOOT (1 MM PER 48 MM) RISE TO RUN RATIO
 - 2) MAINTAIN A MINIMUM 9 INCH (229 MM) AIR SPACE CLEARANCE TO COMBUSTIBLES, WIRE, AND INSULATION
 - 3) INSTALL SUPPORT STRAPS AT 5 FT (152 CM) HORIZONTAL INTERVALS AND AT ELBOWS

FIGURE 15- ROOF PENETRATION DETAILS

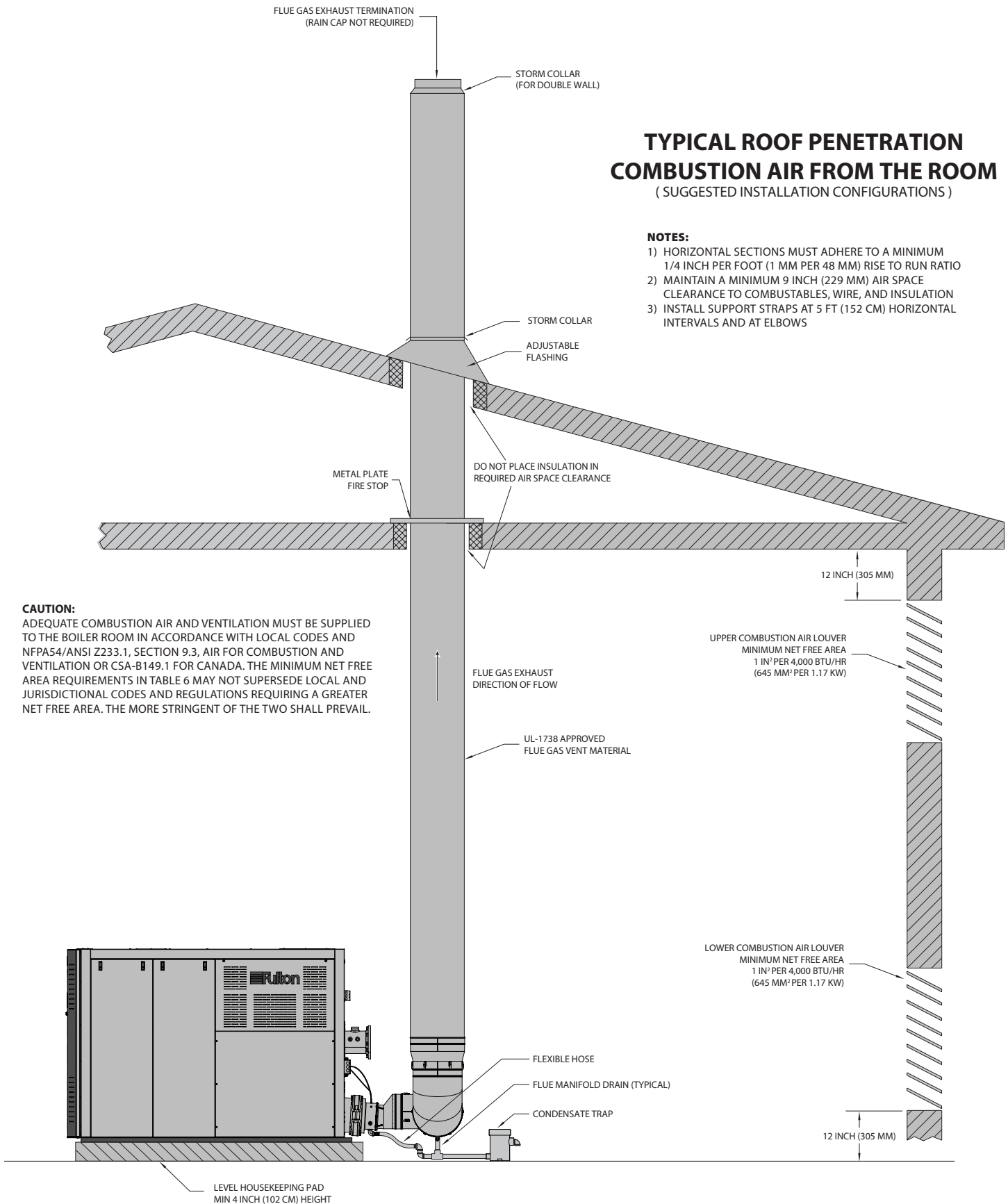

FIGURE 16 - ROOF PENETRATION WITH COMBUSTION AIR LOUVERS DETAIL

TYPICAL SIDE WALL PENETRATIONS
(SUGGESTED INSTALLATION CONFIGURATIONS)

NOTES:

- 1) HORIZONTAL SECTIONS MUST ADHERE TO A MINIMUM 1/4 INCH PER FOOT (1 MM PER 48 MM) RISE TO RUN RATIO
- 2) MAINTAIN A MINIMUM 9 INCH (229 MM) AIR SPACE CLEARANCE TO COMBUSTIBLES, WIRE, AND INSULATION
- 3) INSTALL SUPPORT STRAPS AT 5 FT (152 CM) HORIZONTAL INTERVALS AND AT ELBOWS

CAUTION:

SEPARATE AIR INTAKE AND EXHAUST TERMINATIONS AS FAR AS POSSIBLE TO PREVENT FLUE GAS RECIRCULATION (FGR) DURING DIFFERENT WIND CONDITIONS.

WALL TERMINATIONS DETAIL VIEW

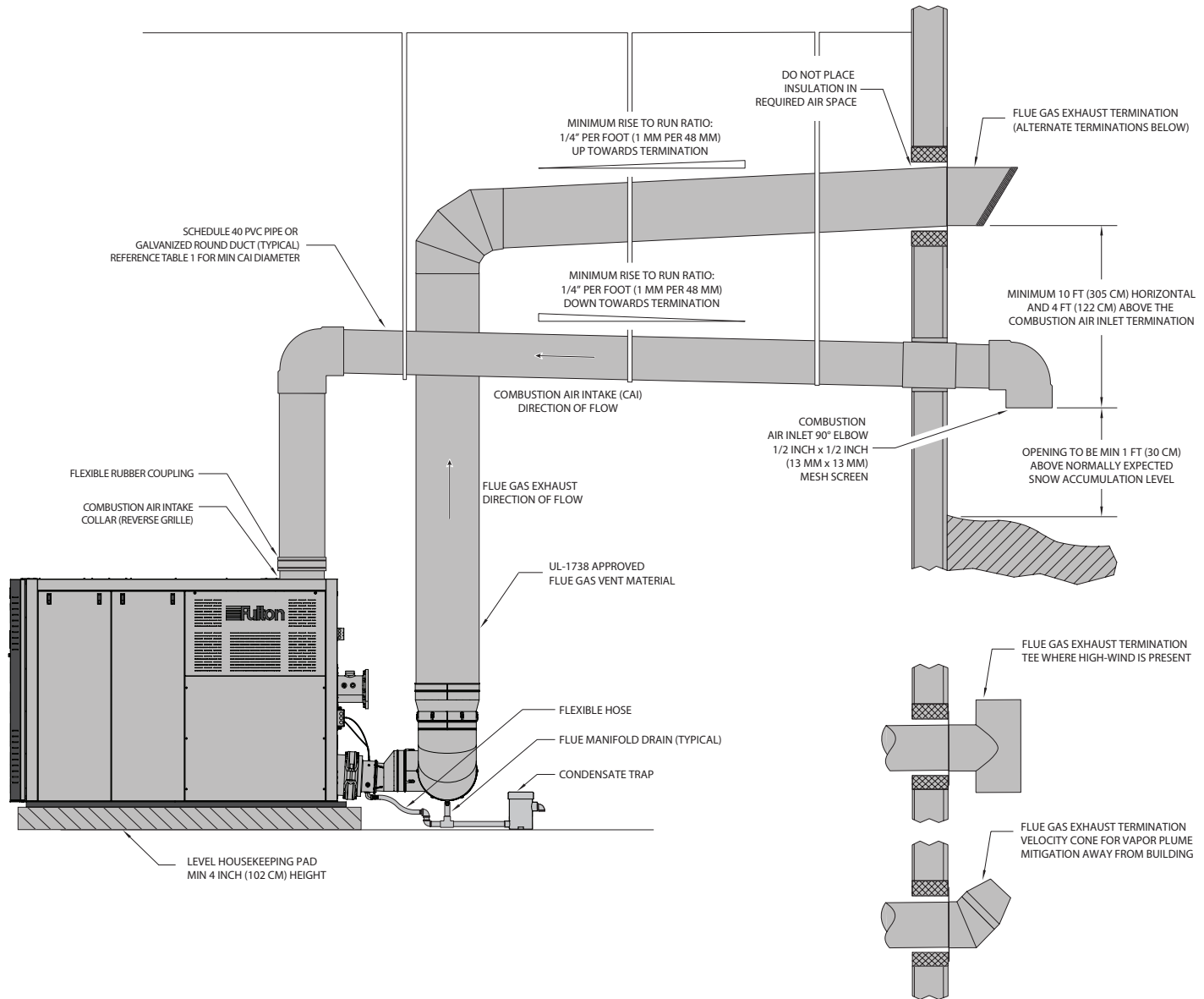
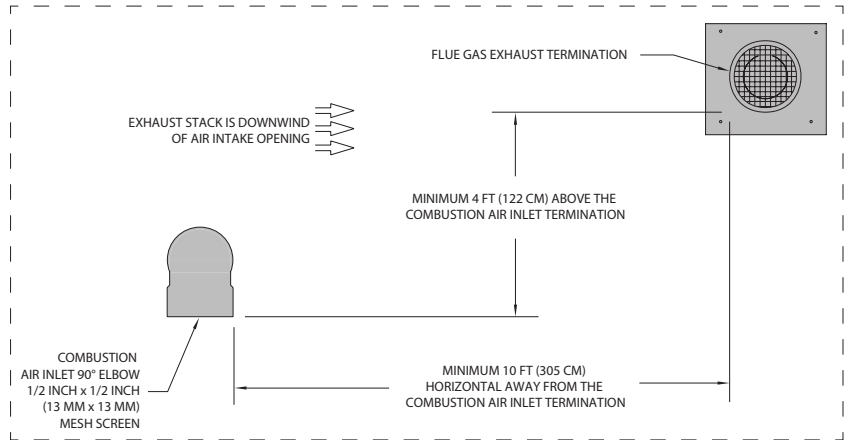

FIGURE 17 - SIDEWALL PENETRATION DETAIL

WARNING

All information in this manual is for reference and guidance purposes, and does not substitute for required professional training, conduct, and strict adherence to applicable jurisdictional/professional codes and regulations.

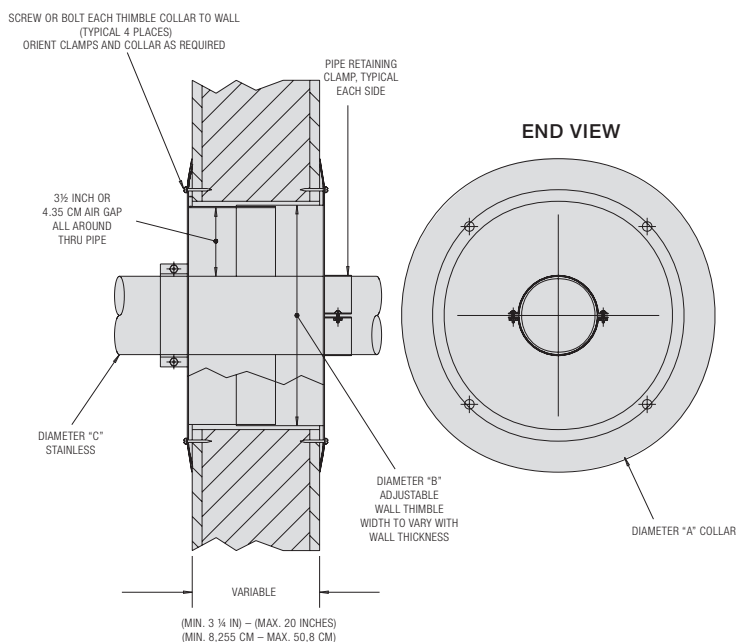

FIGURE 18- WALL THIMBLE INSTALLATION

■ Wall Thimble Installation

Adhere to the following for installation (see Figure 18):

1. The thimble is inserted through the wall from the outside.
2. Secure the outside flange to the wall with nails or screws, and seal with adhesive material.
3. Install the inside flange to the inside wall, secure with nails or screws, and seal with adhesive material.
4. Pass the vent pipe through the thimble from the outside and join to the rest of the vent system. Seal the pipe to the thimble flange with adhesive material.
5. Install two pipe retaining clamps around the intake as well as vent pipes on both ends of the wall thimble (on the inside and outside of the wall) through which intake and vent pipes are passed. They will prevent the intake and vent pipes from being pushed or pulled.

■ Roof Vent Termination

Adhere to the following for installation (see Figures 15, 16):

1. The minimum vent height should extend at least 3 feet (0.9 m) above the roof, or at least 2 feet (0.6 m) above the highest part of any structure within 10 feet of the vent.
2. When installing inlet and exhaust terminations above the roof, the exhaust outlet must be installed 4 feet (1.22 m) minimum above and 4 feet (1.22 m) minimum downwind from air supply inlet to prevent exhaust recirculation. Greater separation is strongly recommended.

■ Side Wall Vent Termination

Adhere to the following for installation (see Figure 17):

- *NOTE: The vent termination is joined to the vent pipe outside the wall. Use the same joining procedures for vent pipe and fittings.*
- 1. When penetrating a non-combustible wall, the hole through the wall must be large enough to maintain the pitch of the vent and provide sealing. Use adhesive material to seal around the vent on both sides of the wall. When penetrating a combustible wall, a wall thimble must be used.
- 2. High-wind areas may require special termination consideration. See Figure 17.
- 3. The termination of the vent system must be at least 12 inches (30.48 cm) above the finished grade, or at least 12 inches (30.48 cm) above normal snow accumulation level (for applicable geographical areas).
- 4. The termination of the vent system shall not be located over traffic areas such as public walkways, or over an area where condensate or vapor could create a nuisance or hazard.
- 5. Do not terminate below operable windows and building openings unless exception is granted by the authority having jurisdiction.
- 6. The vent terminations must be at least 4 ft (1.22 m) from electric meters, gas meters, regulators, and relief equipment.
- 7. When installing inlet and exhaust terminations on the same wall, the exhaust outlet must be installed 4 feet (1.22 m) minimum above and 10 feet (3.05 m) minimum downwind from air supply inlet to prevent flue gas recirculation. Greater separation is strongly recommended.
- 8. Under certain wind conditions, some building materials may be affected by flue products expelled in close proximity to unprotected surfaces. Sealing or shielding of the exposed surfaces with a corrosion resistant material (such as an aluminum sheet) may be required to prevent staining or deterioration. Flue should be directed away from surfaces, if possible.

Removing an Existing Boiler

When an existing boiler is removed from a common venting system, the common venting system is likely to be too large for proper venting of the appliances remaining connected to it.

At the time of removal of an existing boiler, while the other appliances remaining connected to the common venting system are not in operation, the following steps should be followed with each appliance remaining connected to the common venting system placed in operation:

1. Seal any unused openings in the common venting system.
2. Visually inspect the venting system for proper size and horizontal pitch and determine that there is no blockage or restriction, leakage, corrosion or other deficiency, which could cause an unsafe condition.
3. Insofar as is practical, close all building doors and windows and all doors between the space in which the appliances remaining connected to the common venting system are located and other spaces of the building. Turn on clothes dryers and any appliances not connected to the common venting system. Turn on any exhaust fans, such as range hoods and bathroom exhausts, so they will operate at maximum speed. Do not operate a summer exhaust fan. Close fireplace dampers.
4. Place the appliance being inspected in operation. Follow the lighting instructions. Adjust the thermostat so that the appliance will operate continuously.
5. Test for spillage at the draft hood relief opening after 5 minutes of main burner operation. Do not use the flame of a match or candle or smoke from a cigarette, cigar or pipe.
6. After it has been determined that each appliance remaining connected to the common venting system properly vents when tested as outlined above, return doors, windows, exhaust fans, fireplace dampers and any other gas-burning appliance to their previous conditions of use.
7. Any improper operation of the common venting system should be corrected so the installation conforms with the National Fuel Gas Code, ANSI Z223.1. When resizing any portion of the common venting system, the common vent system should be resized to approach the minimum size as determined using the appropriate tables.

WARNING

All information in this manual is for reference and guidance purposes, and does not substitute for required professional training, conduct, and strict adherence to applicable jurisdictional/professional codes and regulations.

Assembly of Fulton Multi-Skid Systems

Adhere to the following for multi-skid engineered systems:

1. Refer to the Fulton mechanical/electrical drawings during assembly.
2. Ensure that equipment orientation allows for operation interface and maintenance.
3. Align the skids as shown on the drawings ensuring that skid fasteners (skid joint angles) are matched. The skid joint angles are a matched set and the edges of the fasteners should be exactly aligned.

► *NOTE: Do not bolt the skids to the housekeeping pad/floor until all of the piping has been reassembled and tightened.*

4. Ensure the skids are level and flat before fastening the skids together with the supplied bolts. The skids should be leveled front to back, side to side and corner to corner. Failure to properly level the skids will result in piping misalignment. A level or laser level should be used to verify skid alignment (when a standard level is used, the length should be appropriate for the skid). If assembling multi-component support stands, attach sections using the supplied bolts through the tank frame mounting plates. These should be hand tight until all of the piping is assembled.

► *NOTE: Skids are leveled at the factory using a laser level.*

5. Connect the piping between the skids by matching the union connections and/or flange stamps and tightening. Refer to the mechanical drawing as necessary to confirm location of spool pieces etc. as the flange stamps are shown on the drawing in hexagonal callouts. The flange stamps should be matched and aligned (the flange stamps should be directly across from one another. Rotating a flange will result in piping misalignment). Bolts should be hand tight until all of the piping is assembled. Refer to the appropriate instructions to tighten the flanges to the required torque specifications. Support pipe runs as required.
6. Ensure that a low point drain is installed in the piping.
7. Connect the conduit runs between the skids and tighten conduit connectors.
8. Locate the supplied wiring for the equipment and pull wiring through the appropriate conduit runs. Electrical wires are labeled for easy landing. Connect all wiring per the Fulton supplied electrical drawings.
9. If a header is supplied, mount the header as shown in the mechanical drawing.

► *NOTE: For piping supplied in sections, make up and connect hand tight until all sections are in place to ensure sections align properly. Sections are match marked for reassembly.*

10. Tighten all connections, including threaded and flanged factory connections which may loosen during shipment.

11. Pneumatically test the piping (at 15 psig [103 kPa] maximum) prior to filling the systems.
12. Check bolts and connections for tightness after the first heat up cycle. Retorquing may be required.

Electrical Connections and Devices

► *NOTE: This boiler is factory configured for site voltage and is not intended for field conversion. See data plate on rear of boiler cabinet for rating.*

The boiler is designed to operate within the following limits at the connection terminals:

- AC power supplied is within +/- 10% of the packaged boiler rated voltage with the rated frequency applied; or AC power supplied is within +/- 5% of the rated frequency and with the rated voltage; or a combined variation in voltage and frequency of +/-10% (sum of absolute values) of rated values provided the frequency variation does not exceed +/-5% of rated frequency.
 - When installed in a 208/3/60 service, the minimum supply voltage applied to the boiler terminals is 207 volts and must always be met. This boiler is not designed for use on High-Leg Delta electrical service. A transformer (not provided) will be required to convert High-Leg Delta to standard Delta or Wye service.
 - When installed in a 575/3/60 service, the maximum supply voltage applied to the boiler terminals is 600 volts and must always be met.
- *NOTE: Operating outside requirements may de-rate the boiler and/or damage electrical components. There is no warranty on components that fail due to improper electrical service.*

Full Load Amps (FLA) is the measured amperage for the boiler at its maximum operating condition at rated voltage. The type of breaker/fusing selected, in combination with the FLA, will affect proper circuit sizing/protection. Please refer to your state's adoption of NEC or the authority having jurisdiction for proper sizing/selection. Refer to Table 1 for FLA requirements.

A connection is provided at the back of the unit for high voltage wiring. A conduit knock-out is provided on the top of

the unit for low voltage and communication wiring. Do not run Building Management System (BMS), low voltage wiring, or any other communication wiring into the high voltage box. Do not relocate connection locations.

The Endura+ cabinet has removable panels to facilitate access. Do not run conduit through or over access panels.

Adhere to the following when making electrical connections:

1. Install wiring in accordance with NEC Sec. 110.3(B) or CSA C22.1 for Canada for a maximum recommended branch circuit voltage drop of 3% and a maximum total voltage drop for a combination of both branch circuit and feeder not to exceed 5%.
2. Install wiring and ground in boiler in accordance with authority having jurisdiction or in absence of such requirements National Electrical Code, ANSI/NFPA 70.
3. Connect power to the boiler using connectors rated for the minimum in Table 1, and are compliant with local electrical codes.
4. Provide separate power supplies for external devices. Do not power external devices (example: isolation valves, draft systems) through the boiler.

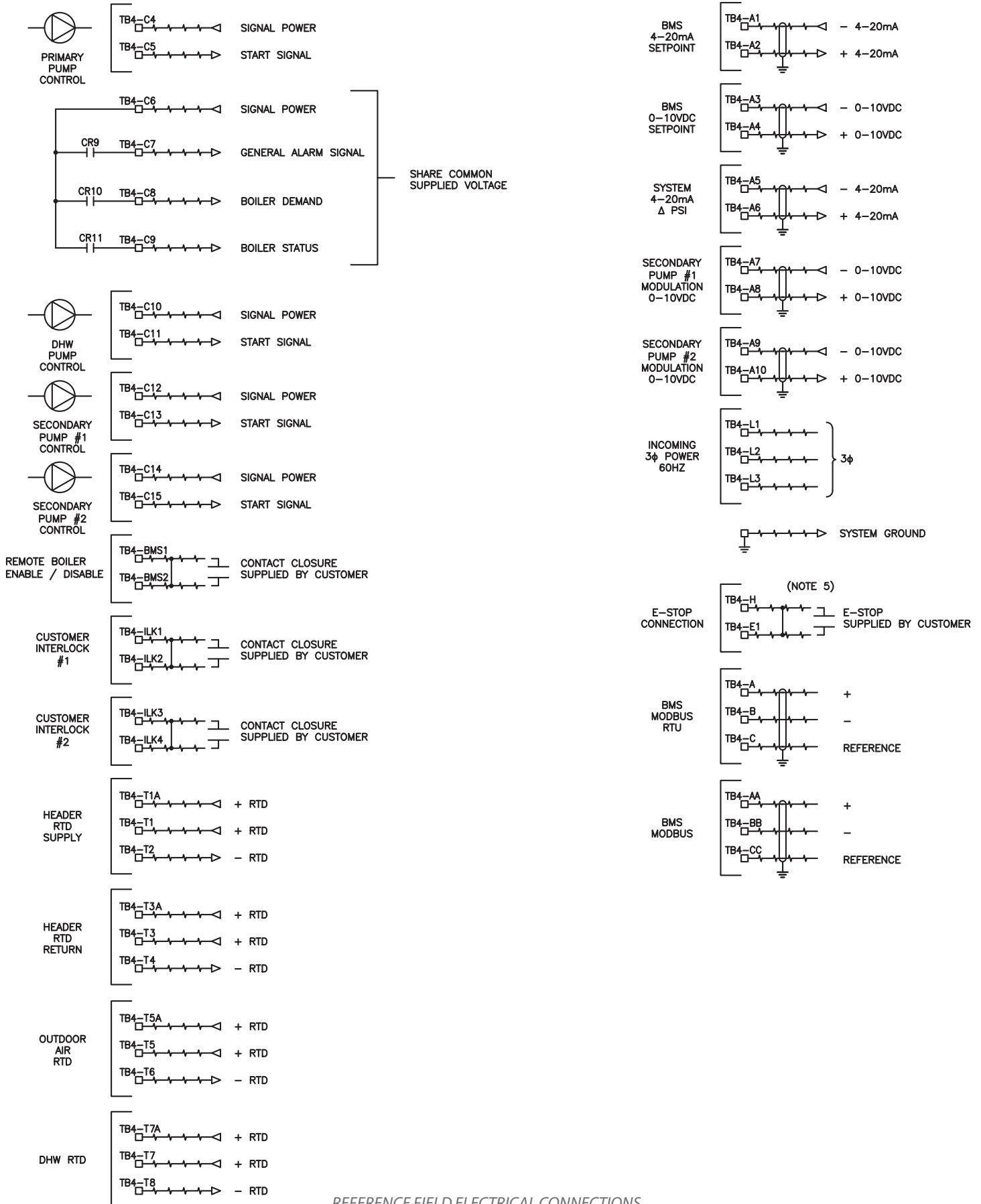

REFERENCE FIELD ELECTRICAL CONNECTIONS

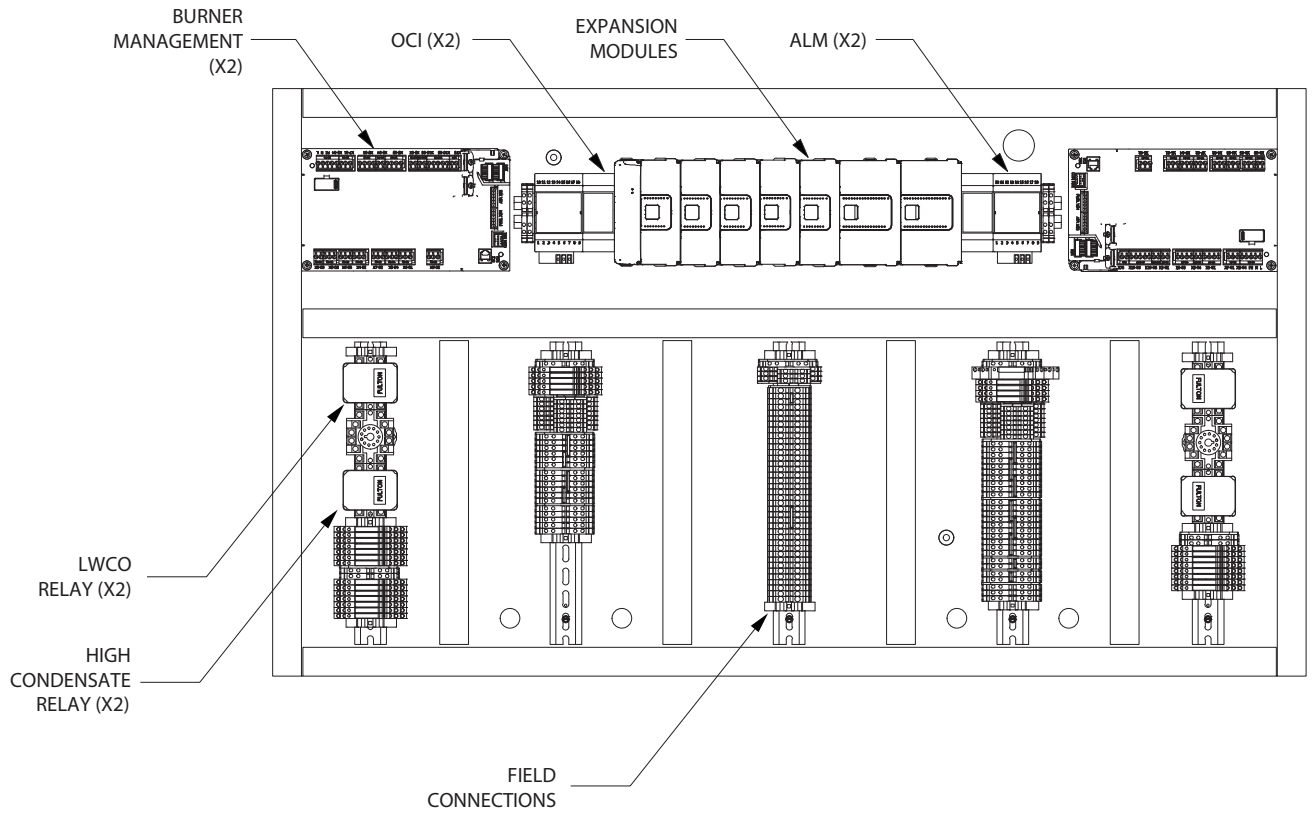

FIGURE 19 - ELECTRICAL CONTROLS LAYOUT

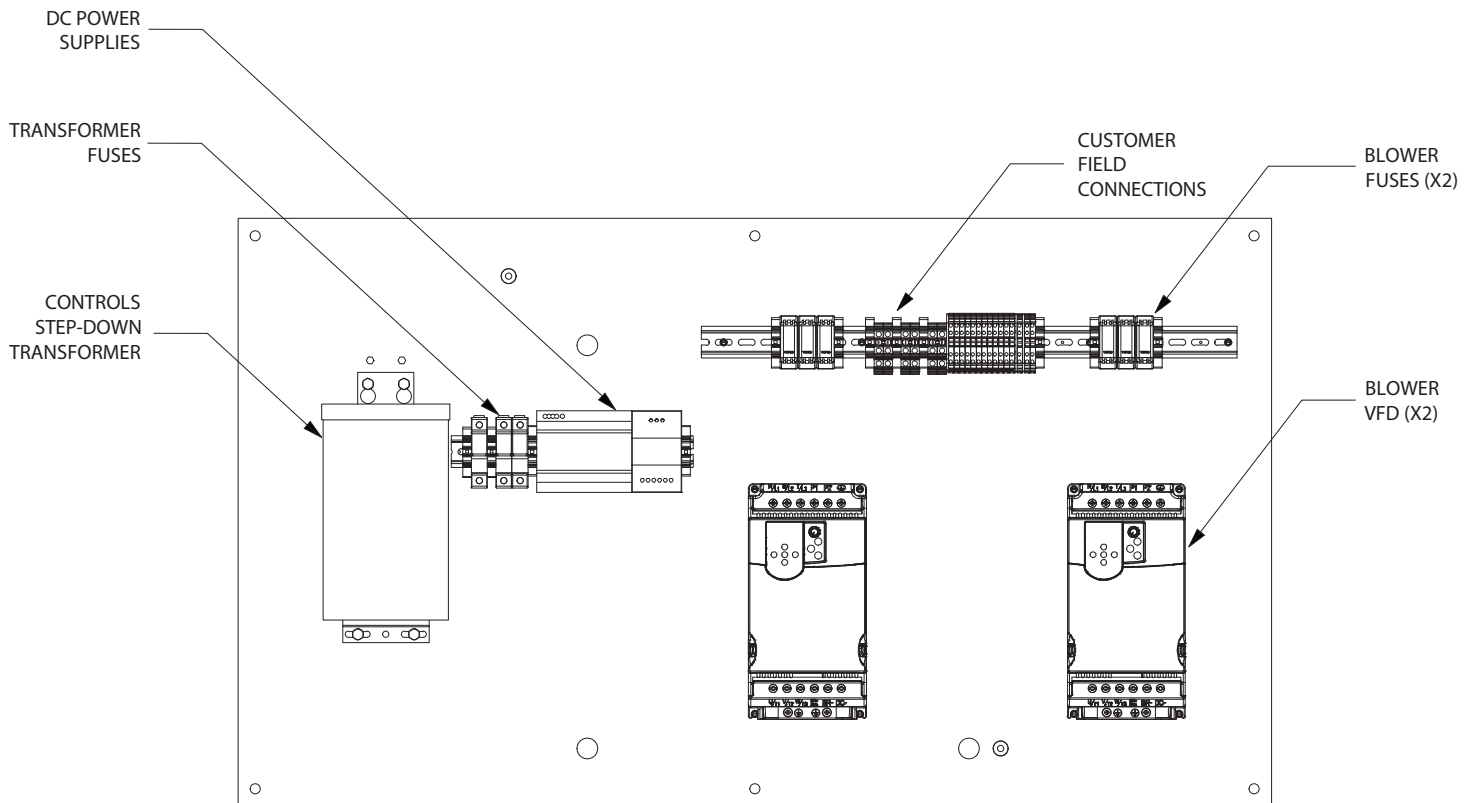

FIGURE 20 - ELECTRICAL MAIN POWER LAYOUT

■ Junction Box Locations for Field Wiring

Connections (Figure 21) are provided for routing field wiring to the boiler control panel. Do not run wiring directly through the removable or hinged panels doors.

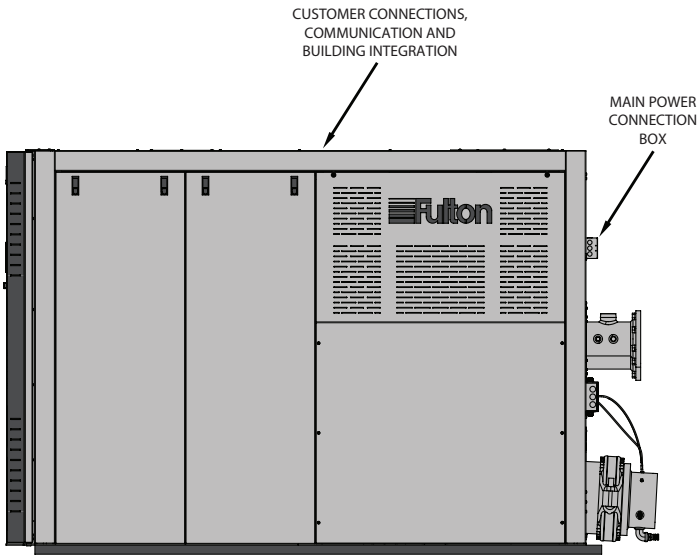

FIGURE 21 – ELECTRICAL CONNECTION LOCATIONS (TYPICAL)

■ Electrical and Controls Options

The electrical and controls options required and supplied will vary depending on the unique requirements and piping arrangements of the hydronic system. See **Electrical Schematic Diagrams** for locations of field wiring connections on the below electrical devices and controls options. See Figures 19-20 for typical electrical layout. Layout varies by model.

The rating of each external device contact is the maximum allowable amperage of the contact.

► INTEGRATED LEAD/LAG SEQUENCING WIRING

1. The Endura+ includes integrated sequencing capabilities for up to ten boilers. When configured, the boiler control system will automatically lead/lag boilers and operate burner firing rates in parallel as necessary to maintain a hydronic setpoint.
2. The lead boiler, and all lag boilers, are automatically rotated.
3. The supply header temperature sensor must be utilized. Wire the sensor to a boiler "header RTD supply" connection and install downstream of the boilers in the common supply water header for proper operation of the sequenced plant. (See Figures 4 - 7).

4. Additional devices and sensors may be required, and will vary by application.
5. Communication between boilers is performed using an industrial Ethernet/IP network protocol. The Endura+ boilers must be on a private network not shared with other equipment or devices. Cable type must be Cat5e or Cat6. Two boilers may be directly connected; an IP switch is required for 3 to 10 boilers. See Figure 22. Install the IP switch in a clean, dry location.
6. See the **Operation** section for information on programming this feature.

► INTEGRATION WITH THE MODSYNC SEQUENCING SYSTEM

Reference the Installation, Operation & Maintenance Manual and Electrical Schematic for the ModSync Sequencing System. Communication requires shielded, three-wire twisted pair Belden 3106A or equivalent. Shield must be grounded at one end only and tied directly to Earth ground.

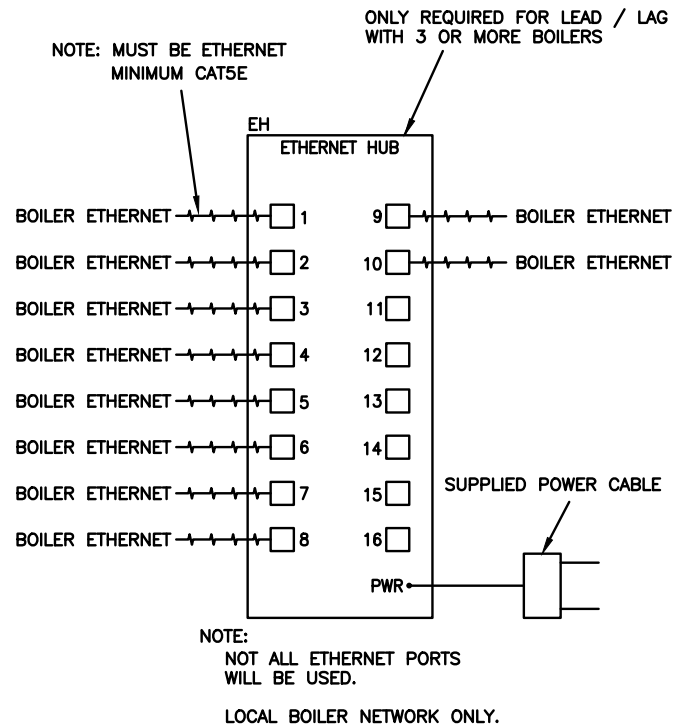

FIGURE 22 – ETHERNET-IP FIELD WIRING

▶ SUPPLY HEADER TEMPERATURE SENSOR

1. A field-installed hydronic supply sensor and 1/2" NPT well are used for temperature control.
2. This sensor is required for any multiple boiler installation utilizing the integrated sequencing capabilities of the Endura+.
3. This sensor is required for single boiler installations with primary-secondary piping arrangements to monitor the primary loop.
4. The sensor monitors hydronic loop temperature in the common supply piping as a process variable for sequencing and modulation purposes. The control uses this information when comparing actual loop temperature to setpoint.
5. Install the sensor downstream of the boilers in the common supply water header. The well must be directly in the path of flow and not isolated with a valve to provide an accurate temperature reading. Do not install the supply header temperature sensor in the return water header.
6. See Figures 4 – 7 for the proper installation location in hydronic piping.

▶ OUTDOOR AIR TEMPERATURE SENSOR KIT

1. If outdoor air temperature reset capabilities are to be utilized, an outdoor air temperature sensor kit is required and field wired to a boiler.
2. An outdoor air temperature sensor kit is not required if using fixed setpoint (no outdoor reset), or if the boiler control is receiving an external hydronic setpoint signal over a communication protocol or analog signal.
3. The sensor must be installed on an exterior wall, in a location that will not be exposed to direct sunlight or influenced by other mechanical equipment.

▶ DOMESTIC HOT WATER (DHW) TEMPERATURE SENSOR

1. This Endura+ boiler is capable of providing indirect domestic hot water through a heat exchanger. A domestic hot water temperature sensor is used for this application. The Endura+ boiler is for closed loop applications only; open loop must not be directly heated by the boiler.
2. The sensor may be installed in the domestic hot water constant recirculation supply piping, or the domestic hot water storage tank.

▶ VARIABLE SPEED SYSTEM PUMP CONTROL

1. The boiler controller provides start/stop and variable speed control for two system (secondary) pumps, one duty plus one backup, with automation rotation. The pumps cannot be powered directly through the boiler panel; a variable speed drive (not provided) is required.
2. Pump modulation is provided via a 0-10 VDC output signal for each pump.
3. The pump start/stop contacts have a maximum rating of 6 Amps at 120 VAC.

▶ DEDICATED BOILER PUMP CONTROL

1. Some installations may utilize primary-secondary piping arrangements instead of variable primary piping arrangements. In these instances, the boiler (primary) loop is decoupled from the system (secondary) loop, and a dedicated boiler pump will be required to provide flow through the boiler.
2. The boiler controller provides a dedicated boiler pump start/stop signal only; the pump cannot be powered through the boiler panel. An external motor starter or variable speed drive (not provided) is required to control the circulator pump.
3. The pump contact has a maximum rating of 6 Amps at 120 VAC.
4. Can be modulated only if system pump feature is not used. A 0-10 VDC output is provided.

▶ MODBUS INTEGRATION

Communication requires shielded, three-wire twisted pair Belden 3106A or equivalent daisy chain. Shield should be grounded at one end only and tied directly to Earth ground.

▶ ALTERNATE COMMUNICATION PROTOCOL GATEWAY

Reference the **BACnet Protonode Start-Up Guide** for BACnet protocol integration.

▶ REMOTE BOILER ENABLE/DISABLE

1. A contact may be utilized to enable and disable each boiler individually. Remove the jumper, and wire to a remote control panel.
2. Closing the contact enables the individual boiler to become available to start. When the contact is open, the boiler will remain in a disabled state.
3. The remote boiler enable/disable contact provides a 24 VDC signal. **Do not apply an external power source to the remote boiler enable/disable contact; wire only to dry contacts.**
4. Modbus remote boiler enable/disable is also available.

▶ REMOTE ANALOG SETPOINT

1. An external hydronic loop setpoint signal may be sent using an analog signal. This may be either 4-20 mA or 0-10 VDC.
2. When using integrated lead/lag functionality, the setpoint signal may be sent to one boiler only. See section on Universal Data.

▶ GENERAL ALARM CONTACT

A dry contact is provided for annunciation of a general alarm condition. It is rated for 6 Amps maximum.

▶ AUXILIARY (2ND) LOW WATER CUTOFF

1. This hydronic boiler includes one factory installed low water cut off (LWCO) device per module in compliance with CSD-1. Some authorities having jurisdiction (AHJ) may require the use of a 2nd (auxiliary) LWCO per module.
2. Where required, probe type LWCO (P/N 2-40-000418) may be installed. The probes must not be isolated from the boiler by any valve.
3. Remove the jumper, and install the low water relay into the 2nd LWCO base.
4. Alternate 120 VAC LWCO devices may be used. They are wired to the jumper terminal blocks.

▶ BOILER STATUS CONTACT

A dry contact is provided for remote monitoring of boiler status. When the main gas valve is enabled, the contact is closed.

▶ BOILER DEMAND CONTACT

A dry contact is provided for remote monitoring of boiler demand. When the boiler has a call for heat, the contact is closed.

▶ AUXILIARY SAFETY INTERLOCK FOR EXTERNAL DEVICES

1. When a module receives a call for heat, the startup sequence first checks for completed interlock circuits. If an interlock circuit is open, the control will not begin the ignition sequence until it is closed.
2. A jumper is factory installed in the interlock circuits. For applications requiring a safety interlock, this jumper may be removed with terminals wired into the dry contacts of an external device.
3. The interlock contacts provide a 24 VDC signal. **Do not apply an external power source to the interlock contacts; wire only to dry contacts.**
4. Typical uses for the safety interlock include but are not limited to: motorized isolation valve end switches, proof of exhaust draft assist fan operation, motorized combustion air intake louvers.
5. Multiple safety interlocks may be used, wired in series.
6. Interlocks may be renamed for simpler troubleshooting.

▶ EMERGENCY STOP (E-STOP)

1. A contact is provided to perform an emergency shutdown of the boiler. Remove the jumper and wire to an emergency shutdown switch or remote control panel.
2. Opening the contact will shut down the boiler.
3. The E-Stop contact provides a 120 VAC signal. **Do not apply an external power source to the E-Stop contacts; wire only to dry contacts.**

INTRODUCTION

1

INSTALLATION

2

OPERATION

3

MAINTENANCE

4

SERVICE DOCUMENTS

5

⚠ WARNING

All information in this manual is for reference and guidance purposes, and does not substitute for required professional training, conduct, and strict adherence to applicable jurisdictional/professional codes and regulations. Failure to follow instructions may result in a fire or explosion, causing property damage, personal injury, or loss of life.

This boiler is equipped with an ignition device, which automatically lights the burner. Do not try to light the burner by hand.

Do not store or use gasoline or other flammable vapors and liquids in the vicinity of this or any other appliances.

*Use only your hand to turn the valve handle. Never use tools. If the knob will not turn by hand, don't try to repair it. Call a qualified service technician. **FORCE OR ATTEMPTED REPAIR MAY RESULT IN A FIRE OR EXPLOSION.***

WHAT TO DO IF YOU SMELL GAS • Do not try to light any appliance. • Do not touch any electrical switch; do not use any phone in your building. • Immediately call your gas supplier from a neighbor's phone. Follow the gas supplier's instructions. • If you cannot reach your gas supplier, call the fire department.

A qualified installer, service agency or the gas supplier, must perform installation and service.

Do not use this boiler if any part has been under water. Immediately call a qualified service technician to inspect the boiler and to replace any impacted part of the control system.

Perform Pre-Start-Up Inspection

Prior to start-up, perform the following:

1. If you smell gas:
 - Do not try to light any appliance.
 - Do not touch any electrical switch; do not use any phone in your building.
 - Immediately call your gas supplier from a neighbor's phone.
2. Ensure the boiler is located with the proper clearances as shown in the **Clearances and Serviceability** section of this manual.
3. Ensure that relief valves have been properly piped to floor drains.
4. Ensure flue gas from the boiler is properly vented.
5. Ensure the water system has been flushed and is free of debris.
6. Ensure combustion air openings are not obstructed in any way and have adequate capacity.
7. Ensure there are no flammable liquids, materials or hazardous fumes present in the environment.
8. Ensure nothing was damaged or knocked loose during installation and/or shipment.
9. Inspect the main gas train and trim assembly to be sure they were not damaged during shipment and/or installation.
10. Verify fan rotation direction is clockwise when viewed from the back of the boiler.

Fill and Purge the System

Completely fill and purge the heating system as follows:

1. Close combination shutoff/purge valve in supply, all drain cocks, the shutoff valve for the pressure reducing (fill) valve, and all manual air vents.
2. Open a system valve, or fill through a drain connection.
3. Water will now begin to fill the system. Open the safety relief valve. Continue filling until a constant stream of water (no bubbling) is discharged from the safety relief valve.
4. At this point, the system has been initially filled. However, air pockets may still remain at high points in the system and in heating loops above the level of the safety relief valve. It is quite possible, depending on the particular system that all piping above the safety relief valve still contains air. If manual vents are installed on the system high points, these should be opened to vent these locations. When only water is discharged from all vents, the initial purging is complete.
5. With the gas shutoff valve closed, turn on power to the boiler and operate the circulator. Circulate the system water for approximately 30 minutes to move all air to the automatic air separation point.
6. Check temperature/pressure indicator reading, which should equal the pressure-reducing (fill) valve set pressure. No more water should be entering the system. Close the shutoff valve on the cold-water fill line.

7. Visually inspect all pipe joints and equipment connections for leaks. If necessary, drain system, repair leaks and refill/purge the system. If no pressure drop is detected for a period of two hours under pressure, the system may be considered watertight.
8. When purging is completed, make sure the following are open— combination shut-off/purge valve, shutoff valve to pressure reducing (fill valve), shutoff valve in cold water fill line, and shutoff valve in return line.
9. Make sure the following are closed - all drain cocks, the vent on the combination shutoff-purge valve, & all manual vents. Reset zone valves to normal mode of operation and turn off power to boiler.
10. Open fuel shutoff valve, allowing fuel to flow to boiler.

Commission The Boiler

Adhere to the following when commissioning the boiler:

1. Verify with authorized personnel that the gas lines have been purged and leak tested. Do not proceed without verification.
 2. Familiarize all personnel on all aspects of boiler use, safety, and contents of this manual. This includes, but is not limited to, the use of the controls, lighting, and shutdown procedures.
 3. Review the unit-specific burner and control schematics, and follow appropriate instructions.
- *NOTE: Warranty coverage is valid only if the boiler is commissioned ("started up") by a factory authorized service technician with a valid Endura+ Certificate of Registration. The commissioning agency must successfully complete and return the Fulton Installation and Operation Checklist report ("Start-up Report") to Fulton within twelve (12) weeks of start-up. Combustion and maintenance records detailing compliance with the Installation, Operation and Maintenance manual must be produced for warranty consideration.*

■ System Design and Boiler Operation

This boiler must be installed in an appropriately designed system per **Installation** section of this manual.

1. The boiler shall be operated/controlled to ensure the boiler does not cycle more than 12,000 times per year.
2. The hydronic system may be operated with a temperature differential across the boiler inlet and outlet (delta-T) up to 100°F (55.5°C) when using ≥ 35 psi water as the heat transfer fluid. For systems with water/glycol solutions, ensure the delta-T does not exceed 40°F (22°C). The factory default maximum delta-T modifier is 40°F (22°C). Consult your Fulton representative for operating requirements and configuration for applications requiring a higher delta-T.
3. Site-specific conditions, including combustion air temperature, elevation, fuel temperature, calorific value of the fuel, combustion air system design, exhaust system design, voltage fluctuations and other factors, will impact boiler performance.
4. Performance factors affected may include but are not limited to input/output ratings, efficiency, modulation rates and emissions.



WARNING

Do not attempt to start the boiler for any testing before filling and purging the boiler. A dry fire will seriously damage the boiler and may result in property damage or personnel injury and is not covered by warranty.

Before commissioning the boiler, verify with authorized personnel that the gas lines have been purged.

Never attempt to operate a boiler that has failed to pass all the safety checks.

Never leave an opened manual air vent unattended. In the event an opened vent is left unattended, water damage could occur.

For water-only systems, the water pressure at the boiler outlet must be 12 psi or greater at all times while the boiler is in operation. For systems using up to 50% glycol, a minimum of 30 psi is required at the boiler outlet.



CAUTION

Do not use this equipment if any part has been under water or subjected to heavy rains/water. Immediately call a qualified service technician to inspect the equipment and to replace any part of the control system and/or gas control(s) which have been under water.

The thermal shock warranty does not cover damage due to cyclic fatigue.

WARNING

Non-Fulton product information is for reference purposes only. No Fulton document should substitute for full review of documentation available from the component manufacturer.

CAUTION

Commissioning/Start up by a non-Fulton authorized person will void the product warranty.

Please read these instructions and post in an appropriate place near the equipment. Maintain in good legible condition.

Maximum allowable working pressure and operating temperature are 160 psig (1103 kPa) and 210°F (99°C), respectively. Aquastats are set at 200°F (93°C). Operating > 185°F (88°C) may result in nuisance high-limit trips.

- The Fulton factory Test Fire Report should be used as a point of reference in commissioning settings for the boilers in the field, however a factory certified service technician should account for all site conditions when finalizing operational settings.

■ Turndown

All Endura+ boilers are configured at the factory with a default modulation range (turndown ratio). Wind effects on combustion air supply and exhaust terminations, natural draft “stack effect,” and gas delivery systems (among other site factors) will ultimately determine what turndown settings are optimal for each application. Consult your local manufacturer’s representative or service organization with factory authorization specific to the Endura+ product line for guidance.

Operation Modifiers

The Endura+ boiler has built in protection features to modify boiler operation in the event certain system conditions approach or exceed operation requirements. Operation modifiers are intended to supplement, not replace, good practice in system design, installation and operation. The following features are provided and take priority over local or remote instruction:

- The control will automatically reduce the fan speed, air and gas positions should the boiler water exceed the factory default maximum outlet temperature of 185°F. Consult your Fulton representative for operating requirements and configuration for applications requiring higher outlet temperatures up to 200°F.

► **NOTE:** *In the event of a High Limit Aquastat lockout, a manual reset will be required.*

- The difference between the inlet and outlet temperature (delta-T) is monitored. If the delta-T approaches the limit specified in **System Design and Boiler Operation**, the control will reduce the fan speed, air and gas position. The delta-T limit will scale down with lower firing rates as the minimum flow rate limit becomes the dominant parameter. A warning is enunciated after two recoverable events. A non-recoverable event due to zero or low water flow will trigger a low flow alarm.

Siemens LMV3 Control

The Siemens LMV3 system is a fully packaged burner management system, linkageless control and first out annunciator.

A Siemens AZL display or ACS410 software will be required (not provided) for the authorized service technician to perform configuration of the LMV3.

The left and right arrow keys are used for scrolling through the menu and changing controller parameters. Pressing the *Enter* button accepts the menu and parameter changes. It is possible to return to the main menu at any time by repeatedly pressing ESC (*Escape*). See Figure 23.

Complete steps per each hear engine module.

FIGURE 23 - SIEMENS AZL DISPLAY

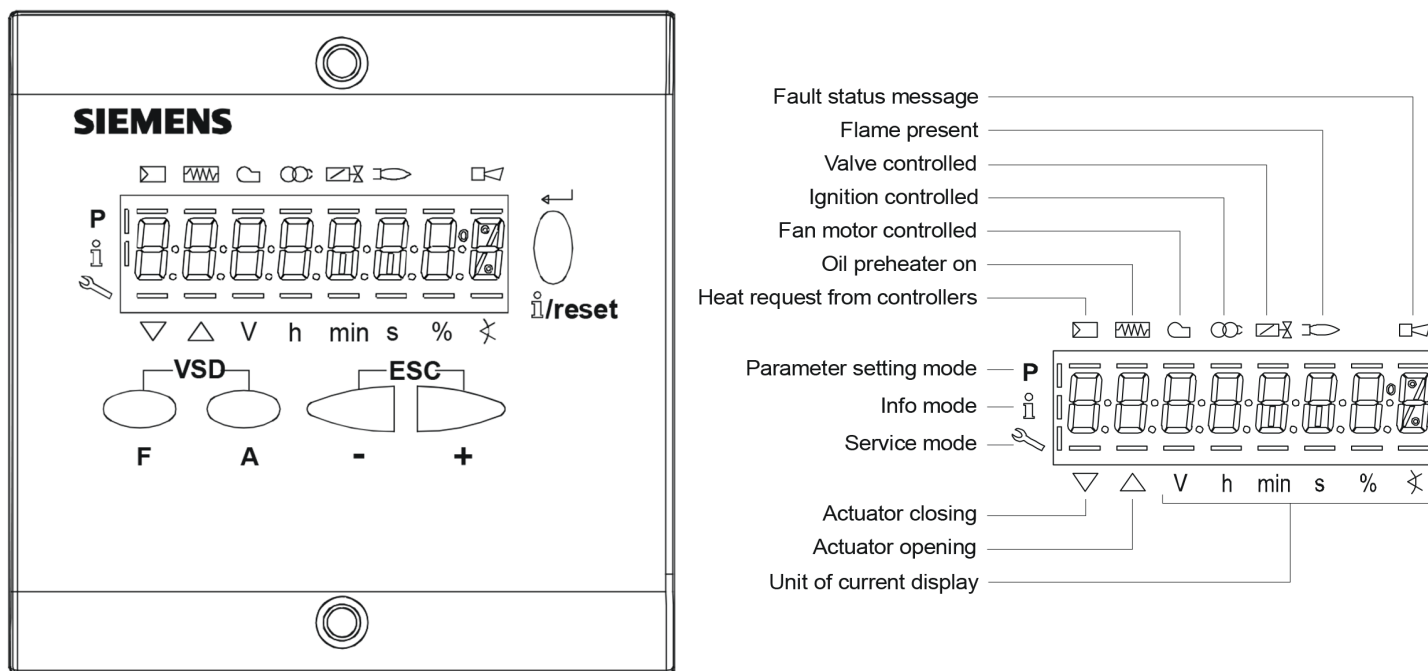

Button	Function
	Button F - For adjusting the fuel actuator (keep depressed and adjust the value by pressing or)
	Button A - For adjusting the air actuator (keep depressed and adjust the value by pressing or)
	Buttons A and F: VSD function - For changing to parameter setting mode P (press simultaneously and plus or)
	Info and Enter button - For navigating in info or service mode * Selection (symbol flashing) (press button for <1 s) * For changing to a lower menu level (press button for 1...3 s) * For changing to a higher menu level (press button for 3...8 s) * For changing the operating mode (press button for >8 s) - Enter in parameter setting mode - Reset in the event of fault - One menu level down
	- button - For decreasing the value - For navigating during curve adjustments in info or service mode
	+ button - For increasing the value - For navigating during curve adjustments in info or service mode
	+ and - button: Escape function (press and simultaneously) - No adoption of value - One menu level up

■ Before Modifying LMV Parameters

The boiler must be placed in "Commissioning Mode" before modifying any LMV parameters. Set-up must be fully completed prior to automatic operation of the boiler.

■ Steps to Enter Parameters

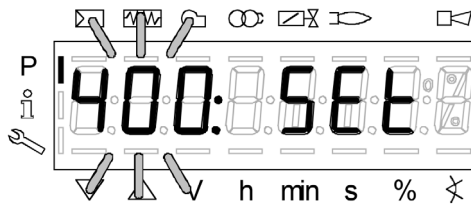
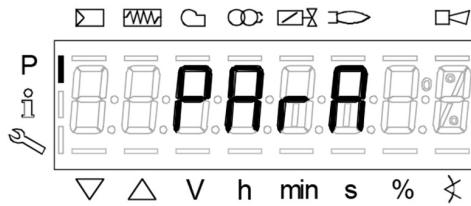
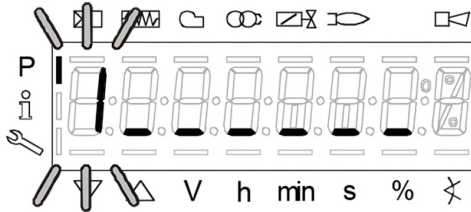
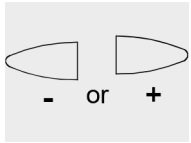
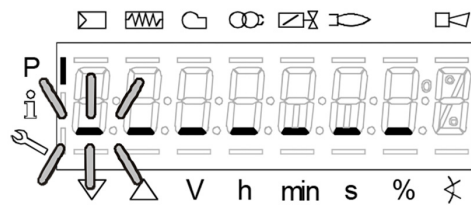
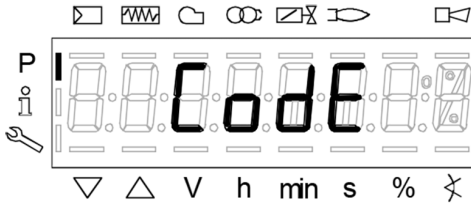
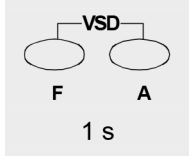

- 1) Press and hold the "F" and "A" buttons simultaneously.
 - a. "Code" will be displayed.
- 2) When releasing "F" and "A", 7 bars appear the first of which flashes.
- 3) Press the "-" or "+" button to select the first number of the national board number and press enter (i/reset) button after each selected number.

► **NOTE: The service password is "00000."**

- 4) After entry of the last number, the password must be confirmed by pressing enter (i/reset) button.
- 5) After correct entry of password, PARa appears for a maximum of 2 seconds.
- 6) Parameter 400 will flash.
 - a. Use the "-" or "+" button for scrolling to the desired parameter.
 - b. Press the enter (i/reset) button to enter the selected parameter level.

■ Adjusting Fuel/Air Curve

► **NOTE:** *Fulton Endura+ boilers are factory test fired and pre-programmed with values in the fuel/air curve (P0-ignition to P9-high fire).*

With the burner on, follow the below steps for making field changes to the fuel/air curve points. A calibrated flue gas analyzer is required to complete these steps and must be properly inserted into the boiler flue exhaust vent while making changes to the fuel/air curve points. The boiler controller must be placed in Commissioning Mode before making any adjustments.

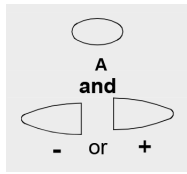
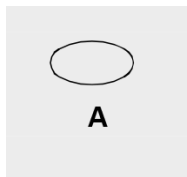
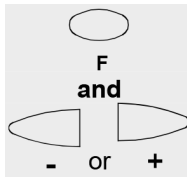
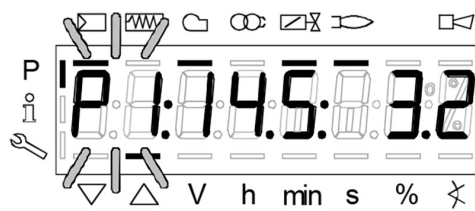
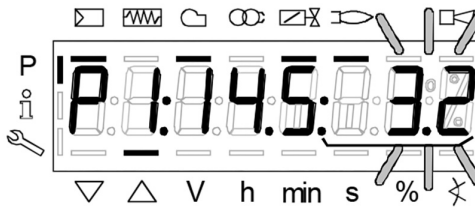
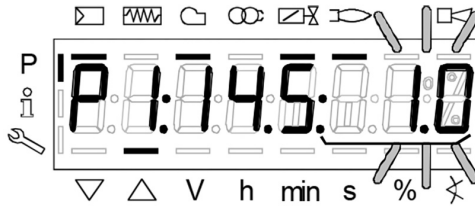
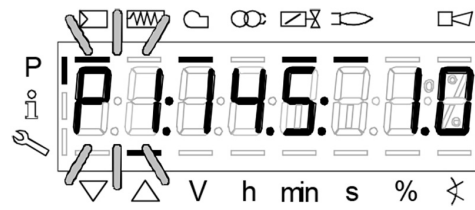
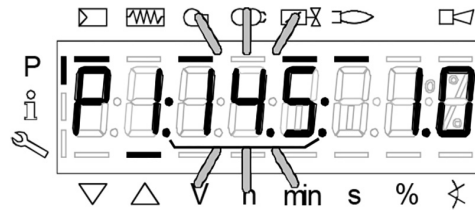
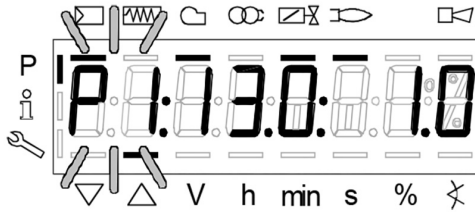
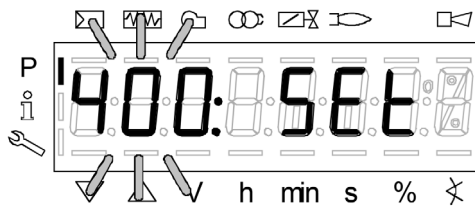

- 1) Confirm position of the fuel selection switch where applicable.
- 2) Enter the password and parameter "400" will flash.
- 3) Press the enter (i/reset) button 2 times.
 - a. "P1" will flash and the curve point will be displayed.

NOTE: P0 is the ignition position. Verify proper combustion at the ignition position.

- 4) With "P1" flashing the fuel or air actuator may be individually selected for combustion adjustments.
 - a. For the fuel actuator keep the "F" button depressed and press the "-" or "+" button to adjust the fuel actuator.
 - i. Any changes are automatically saved.
 - ii. Release the "F" button.
 - b. For the air actuator keep the "A" button depressed and press the "-" or "+" button to adjust the air actuator.
 - i. Any changes are automatically saved.
 - ii. Release the "A" button.
 - c. With "P1" flashing use the "+" for the next curve point and the "-" for going back to the previous curve point.
 - d. Repeat steps "a." and "b." above if changes are required at any other curve point.

Manual Firing Rate Control (Manual Request for Output)

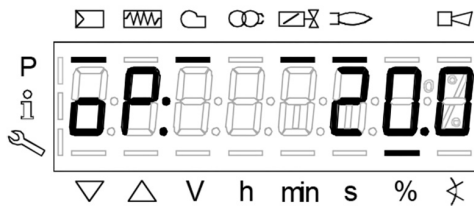

- 1) Burner is in operation mode.
 - a. The display shows oP: on the left, the percentage of the current output on the right.

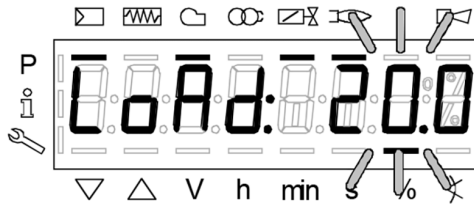
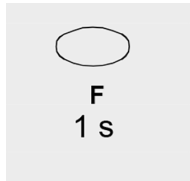

- 2) Press and Hold the F button for 1 second.
 - a. The display shows LoAd; the current output flashes.

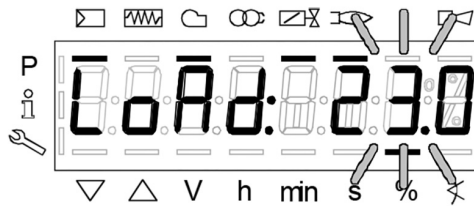
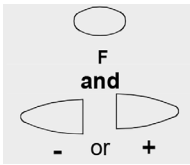

- 3) Still holding the F button press the – or + to adjust the required output in manual.
 - a. The display shows LoAd; still holding the F button the new output flashes.

- 4) Release the F button.
 - a. The current manual output flashes; oP: is still displayed on the left solid indicating that manual control is activated.

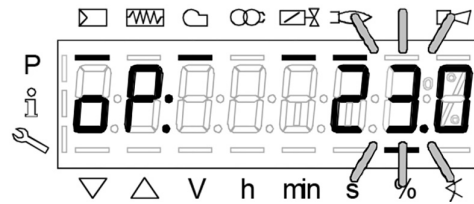

- 5) Press and hold the – and + for 3 seconds to return to automatic mode.
 - a. The output will no longer flash, oP: will be displayed on the left solid and the operating percentage will be displayed on the right.

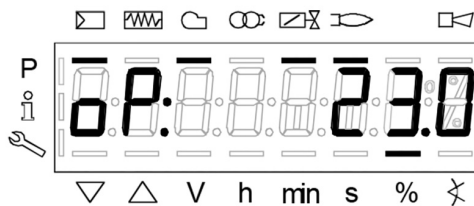
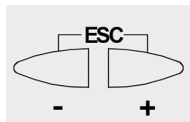

Parameter Backup

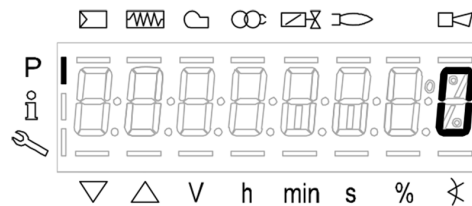
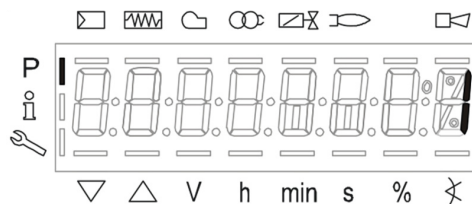
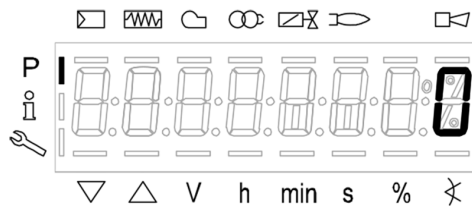
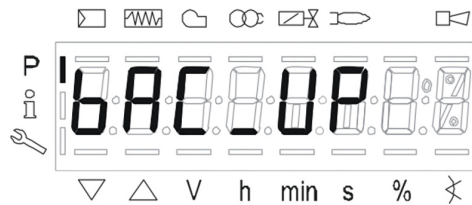
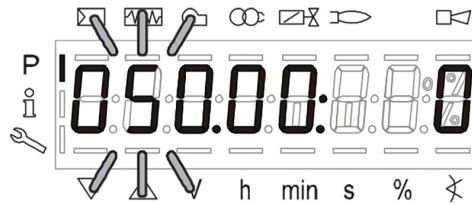
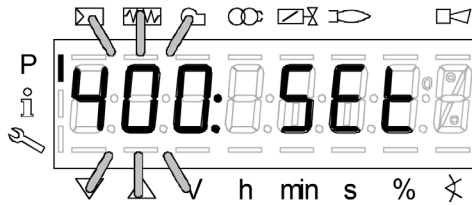

1. Press and hold "F" and "A" until Code is displayed.
 - a. Then enter unit national board number press enter once complete.
2. "400: Set" will be displayed
 - a. Press the "-" arrow three times until "000: Int" is displayed.
 - b. Press the Enter button to get into "100: Int" parameters.
3. Backup procedure:
 - a. Press the "+" button and go to P-050 (050 will be flashing).
 - b. Press enter > bAC_uP is displayed.
 - c. Press enter > 0 is displayed.
 - d. Press "+" button and 1 is flashing
 - e. Press enter, after about 5 seconds a 0 appears on the display indicating the end of the backup process.

► **NOTE:** If an error occurs during the backup process, a negative value is displayed. For troubleshooting, go to error code 137 to view diagnostic code.

reset

Approx.
5 s

■ Parameter Restore

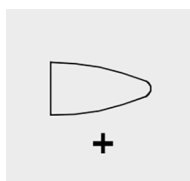
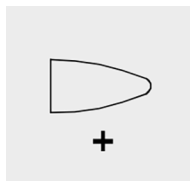
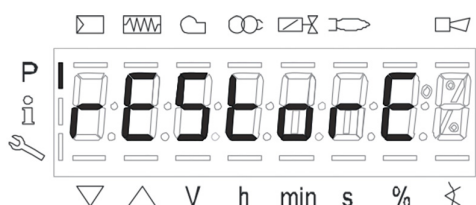
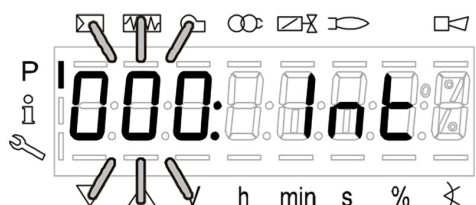
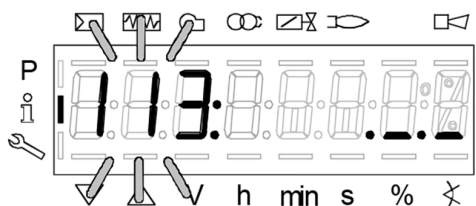
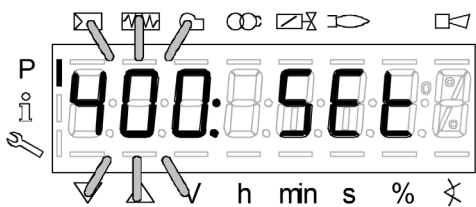

1. Press and hold "F and A" until Code is displayed
 - a. Then enter unit national board number press enter once complete.
2. "400: Set" will be displayed
 - a. Press the "-" arrow two times until "100: PArA" is displayed.
 - b. Press the Enter button to get into "100" parameters.
 - c. Press the "+" arrow until parameter 113 is reach enter into the parameter and record the Burner ID#.
 - d. This is required for performing the Restore process.
3. Restore procedure:
 - a. Go to "000: Int" parameter enter in and go to P-050 (050 will be flashing).
 - b. Press enter > bAC_uP is displayed.
 - c. Press "+" button to select "rEStorE".
 - d. Press enter > 0 is displayed.
 - e. Press "+" button and 1 is flashing
 - f. Press enter, after about 5 seconds a 0 appears on the display indicating the end of the backup process.

► **NOTE:** If an error occurs during the Restore process, a negative value is displayed. For troubleshooting, go to error code 137 to view diagnostic code.

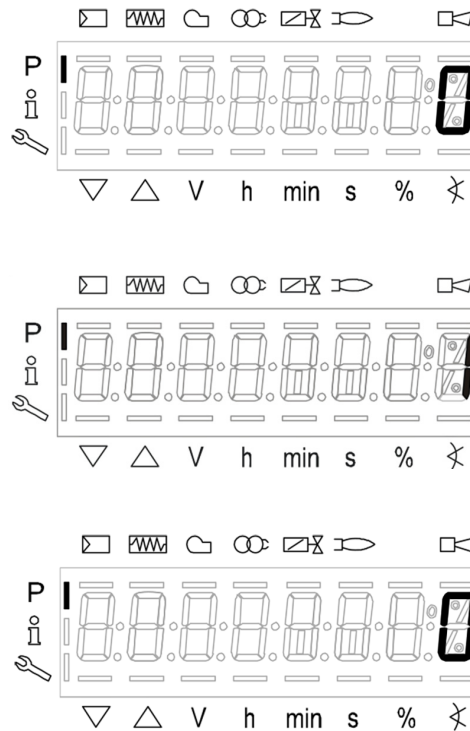
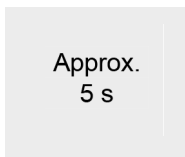
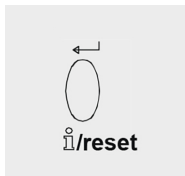

⚠ WARNING

All information in this manual is for reference and guidance purposes, and does not substitute for required professional training, conduct, and strict adherence to applicable jurisdictional/professional codes and regulations.

Non-Fulton product information is for reference purposes only. No Fulton document should substitute for full review of documentation available from the component manufacturer.

■ Speed Standardization

Using the AZL display, adhere to the following procedure:

1. Change 502.1 from 60 to 20.
2. Change 641 to 1, the fan will start, verify rotation and run check.
3. Upon successful completion, 641 will return to zero.
4. Change 502.1 to 60.

WARNING

All information in this manual is for reference and guidance purposes, and does not substitute for required professional training, conduct, and strict adherence to applicable jurisdictional/professional codes and regulations.

Tampering with safety devices or unauthorized bypassing of the boiler control system will void the pressure vessel warranty.

Using the Fulton PURE Control™ Interface

Reference the *PURE Control™ User Manual* for detailed instructions on the controls system. The boiler control system features an integrated color touchscreen display through which many commissioning and operation tasks are performed, including temperature control and multiple boiler sequencing setup. The graphical interface is navigated by touch using your finger or a stylus. The screenshots and information in this section will guide you through the menu screens.

Navigation

The control will enter a screensaver mode (shown below) after several minutes with no interaction. Tap the screen to exit the screensaver.

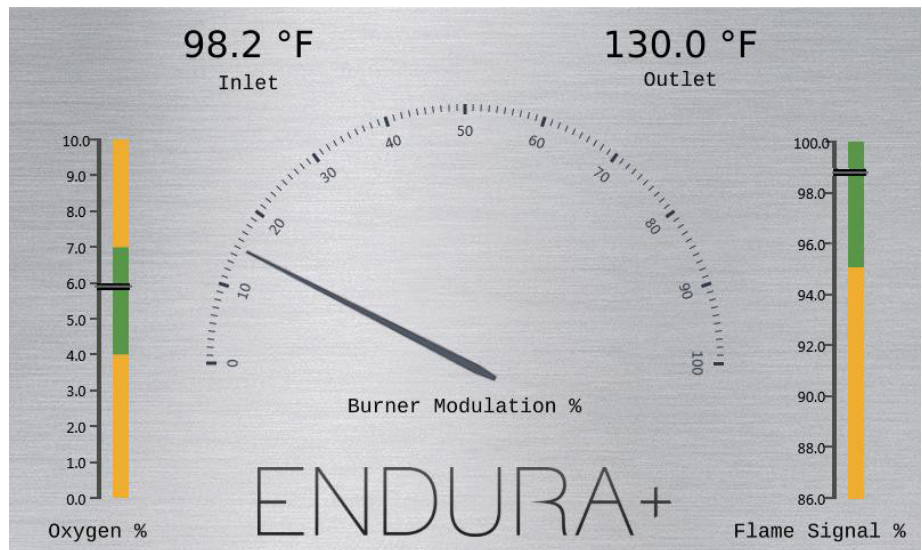



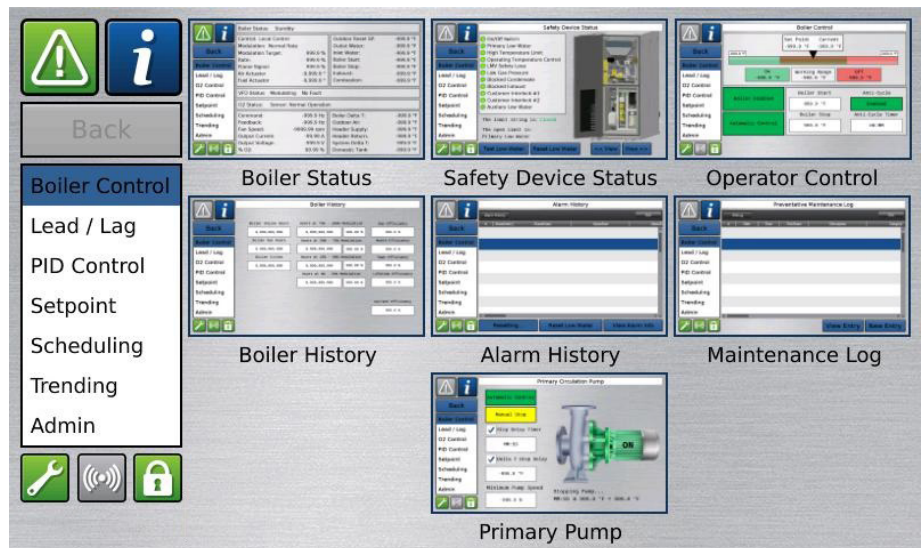









The Menu screens are grouped into categories, and each serves a unique function for changing parameters or viewing statuses. To change categories, tap the desired category in the left sidebar menu. A navigation screen provides access to screens within each category. Tap the "back" button to return to category navigation.



A listing and functional description of each of the graphical icons found within the touchscreen menus is provided below in Table 7.

TABLE 7 - GRAPHICAL ICON REFERENCE MENU

Button	Function
	Returns to the parent category.
	Tap to display information based on the screen currently selected.
	Green: No alarm condition. Tap to see Alarm History .
	Yellow: Warning or Soft Alarm active. Tap to see Alarm History .
	Red: Alarm or Lock-Out active. Tap to see Alarm History .
	Green: Maintenance Inactive. Tap to go to the Maintenance screen.
	Yellow: Time For Service - Tap to go to the Maintenance screen.
	Green: Locked - Some screens may not be accessible as configured by the boiler plant administrator. Tap the icon and enter the administrative password to unlock.
	Yellow: Unlocked - Screens locked by the boiler plant administrator are now accessible. Tap the icon again to lock. The screen will automatically re-lock after 1-10 minutes (user adjustable).
	Green: Lead/Lag Network Active. Tap to enter Ethernet/IP Status .
	Red: Lead/Lag Network Communication Lost or Recovering. Tap to enter Ethernet/IP Status .
	Gray: Lead/Lag Network Inactive. Tap to enter Ethernet/IP Status .

WARNING

All information in this manual is for reference and guidance purposes, and does not substitute for required professional training, conduct, and strict adherence to applicable jurisdictional/professional codes and regulations.

Non-Fulton product information is for reference purposes only. No Fulton document may substitute for full review of documentation available from the component manufacturer.

CAUTION

*A temperature exceeding 120°F** (48 C) in the boiler room may cause premature failure of electrical components. Provisions should be made to maintain an ambient temperature of 120°F** (48 C) or less (the panel box interior should not exceed 125°F** [51 C]).*

****Pumps, PLC or ModSync panels may require lower ambient temperatures or additional cooling.**

 **WARNING**

All information in this manual is for reference and guidance purposes, and does not substitute for required professional training, conduct, and strict adherence to applicable jurisdictional/professional codes and regulations.

Non-Fulton product information is for reference purposes only. No Fulton document should substitute for full review of documentation available from the component manufacturer.

Fulton PURE Control™ Menu Screen Functions

■ Boiler Control

General individual boiler and ancillary functionality is accessed through this category.

▶ BOILER STATUS

Summarizes information and sensor status for the boiler.

▶ SAFETY DEVICE STATUS

Devices will either have a green circle to the left indicating closed circuit or a red circle indicating the device is open. The device indicated as the “open limit” is the first device in the safety circuit open and should be the first device addressed during troubleshooting.

Once the boiler is full of water, the following test of low-water cutoff can be accomplished:

1. Navigate to and tap the *Test Low Water* button on the screen.
2. Reset the Low Water condition by tapping the *Reset Low Water* button.
3. Perform appropriate test for any secondary Low Water controls.

▶ OPERATOR CONTROL

This screen is used for multiple functions: Start/Stop Deviations, Anti-Cycle Timer, and Manual Burner Control.

The start and stop deviations instruct the burner when to enable and disable around the setpoint temperature. Increasing the range will reduce cycling but may result in larger temperature fluctuations.

When in Automatic Control, the temperature controller will modulate the burner to a firing rate necessary to achieve the setpoint. To enter Manual Control, tap the “Automatic Control” button, and it will change to “Manual Control.” Enter a “Manual Firing Rate” in the box, and press OK to confirm. When finished with maintenance, return to this screen and place the boiler back into Automatic Control.

The Anti-Cycle Timer, if used, will prevent the burner from firing for a minimum amount of time between cycles

▶ BOILER HISTORY

Various data points of operational history are summarized on this screen.

▶ ALARM HISTORY

This screen provides a chronological list of alarms. Pressing the “View Alarm Info” button will expand a selected alarm for additional information and troubleshooting tips.

► MAINTENANCE LOG

Access a history of preventative maintenance and repairs. Tapping “View Entry” will expand detail on a previous record. Add a record of service by tapping “New Entry” and completing the record.

► ISOLATION VALVE

This screen will only be accessible if *Isolation Valve* is selected. See **Auxiliary Configuration** in **Admin**.

The isolation valve can be placed in manual control or automatic. When using manual, ensure all boilers are not placed in manual close while the system pumps are in operation. In automatic control, a Close Delay Timer can be set to keep the boiler’s isolation valve open for the prescribed time when a boiler no longer has a call for heat. The Delta T Close Delay feature will hold the boiler isolation valve open until residual heat is removed from the heat exchanger and the Delta T drops to the selected value. When enabled, the isolation valve will not close until both conditions are satisfied. One valve will always remain open when lead/lag is used.

► PRIMARY PUMP

This screen will only be accessible if *Use Pump Control* and *Boiler Pump* is selected. See **Auxiliary Configuration** in **Admin**.

The purpose of this screen is to enable and disable a dedicated boiler pump (primary pump) for Primary / Secondary piping arrangements only.

The pump can be placed in automatic control or manual. In automatic control, the Stop Delay Timer will continue operating the pump for the prescribed time after the call for heat ends. The Delta T Stop Delay will continue operating the pump until residual heat is removed from the heat exchanger and the Delta T drops to the selected value. When enabled, the pump will continue operation until both conditions are satisfied.

► SECONDARY PUMPS

This screen will only be accessible if *Secondary Pumps* is selected. See **Auxiliary Configuration**.

Pumps may be configured to maintain either system delta-P or delta-T. Rotation is automatic.



WARNING

All information in this manual is for reference and guidance purposes, and does not substitute for required professional training, conduct, and strict adherence to applicable jurisdictional/professional codes and regulations.

Non-Fulton product information is for reference purposes only. No Fulton document should substitute for full review of documentation available from the component manufacturer.

WARNING

All information in this manual is for reference and guidance purposes, and does not substitute for required professional training, conduct, and strict adherence to applicable jurisdictional/professional codes and regulations.

Non-Fulton product information is for reference purposes only. No Fulton document should substitute for full review of documentation available from the component manufacturer.

■ Lead/Lag

Integrated multiple boiler sequencing “Lead/Lag” is configured and monitored through this category and **Admin**. Ensure the boilers are on a private Ethernet/IP network shared with no other devices before continuing setup.

To function properly on the network, the **Local Ethernet/IP Address** of each boiler must be specifically set on the **System Configuration** screen in the **Admin** category:

Boiler 1 – 192.168.1.100	Boiler 6 – 192.168.1.105
Boiler 2 – 192.168.1.101	Boiler 7 – 192.168.1.106
Boiler 3 – 192.168.1.102	Boiler 8 – 192.168.1.107
Boiler 4 – 192.168.1.103	Boiler 9 – 192.168.1.108
Boiler 5 – 192.168.1.104	Boiler 10 – 192.168.1.109

Physical wiring of the local boiler network uses Ethernet Port 1. Wiring for the Ethernet/IP network will change based on the number of boilers in the system. For systems with two boilers, a single shielded Ethernet cable can be wired directly between the boilers. For systems with more than two boilers, each boiler will need to have a shielded Ethernet home run back to the Ethernet switch (ships loose in trim kit when ordered).

To enable Lead/Lag functionality, use the **Auxiliary Configuration** screen under the **Admin** category. Set the Number of Boilers field to the number of boilers to be controlled. These steps must be completed at each boiler. Ensure the **Universal Data**, also under **Admin**, is properly configured for data sources.

▶ LEAD/LAG CONFIGURATION

This screen is used to set sequencing preferences.

- *Lead/Lag priority* determines how the boilers are sequenced, either by cycles only, hours only, or an optimized algorithm.
- *Number of boilers* displays how many boilers the Lead/Lag system expects to have under control.
- *Lead start* is how far below setpoint before the lead boiler turns on.
- *Lead stop* is how far above setpoint before the lead boiler turns off.
- The aggressive-passive slider determines how quickly lag boilers are enabled. Slid all the way to the aggressive side, the last lag boiler will come on when the control variable reaches 50%; all the way to the passive side, the last lag boiler will come on at 90% control variable.

■ PID Control

Local PID and firing rate modifiers are accessed in this category.

▶ LOCAL PID

Use the slider to set how passive or aggressive the control will act to meet setpoint when the boiler is in local (standalone) mode. See **Lead/Lag PID** for PID control of plants with multiple boiler sequencing.

▶ LOW FIRE HOLD

The boiler can be locked to low fire rate after ignition for a set period of time. This period of time can be enabled/disabled and adjusted on this screen.

▶ FREEZE PROTECTION

Two stages of freeze protection are provided. Stage 1 is only available if the boiler (primary) pump is enabled in a primary secondary piping system. When the boiler vessel water temperature falls below a configured temperature, the boiler (primary) pump will be enabled until the set temperature has been reached.

Stage 2 enables the burner if the boiler vessel water temperature falls below a configured temperature. The burner is held at low fire until the set temperature has been reached.

▶ OUTLET MONITORING

In addition to the mechanical Aquastat temperature high limit, the boiler includes a digital control soft high limit available on the Outlet Monitoring screen.

- *NOTE: If a high temperature condition occurs exceeding the high limit setting on the mechanical Aquastat, the boiler will require a manual reset accomplished by pressing the red Aquastat reset button.*

The soft high limit acts to prevent nuisance manual reset high limit trips. If the boiler outlet temperature exceeds the soft high limit, the burner will be driven to low fire until the outlet temperature is reduced to the value assigned in the Soft Limit Reset.

▶ COLD START

This feature allows the boiler to slowly reach temperature when receiving a demand at a cold water condition as configured. When enabled, this modifier will take priority over the PID until the configured time or the configured boiler water temperature is reached.



WARNING

All information in this manual is for reference and guidance purposes, and does not substitute for required professional training, conduct, and strict adherence to applicable jurisdictional/professional codes and regulations.

Non-Fulton product information is for reference purposes only. No Fulton document should substitute for full review of documentation available from the component manufacturer.

 **WARNING**

All information in this manual is for reference and guidance purposes, and does not substitute for required professional training, conduct, and strict adherence to applicable jurisdictional/professional codes and regulations.

Non-Fulton product information is for reference purposes only. No Fulton document should substitute for full review of documentation available from the component manufacturer.

■ Setpoint

The boiler or multiple boiler system will maintain supply water temperature based on a setpoint temperature. This setpoint can come from a variety of sources, including by calculation from an outdoor air temperature sensor, a remote signal from the Building Management System (BMS), or from a static manually entered setpoint.

▶ SETPOINT CONFIGURATION

The Setpoint Source screen allows for the selection between the various setpoint sources available.

When in Outdoor Reset mode, the control will automatically calculate the hydronic loop setpoint based on the settings configured on the **Outdoor Reset** screen.

BMS Analog will monitor either the 4-20mA or 0-10VDC contacts for a remote setpoint signal; the **BMS Analog** screens are used for the linearization settings for the control signal.

When in BMS Network mode, the control will maintain setpoint based on the Modbus RTU write point. Protocol conversion gateways are available for alternate communication protocols including BACnet and LonWorks.

▶ OUTDOOR RESET

Outdoor air reset curves are configured through the Outdoor Reset screens. The normal (occupied) setpoint curve and the setback (unoccupied) setpoint curve are configured through separate screens.

The hydronic loop temperature setpoint will be calculated based on configured outdoor air and setpoint high and low temperature values. When the outdoor air temperature reaches a warm weather shutdown Outdoor Air Cutoff temperature, the boilers will be disabled until outdoor air temperature has decreased by the value assigned in the Cutoff Reset.

▶ BMS ANALOG (4-20MA AND 0-10VDC)

High and low setpoint values must be assigned for correct linearization.

■ Scheduling

The Scheduling system allows for the operator to configure when the normal (occupied) setpoint will be maintained. When outdoor reset is enabled, the normal setpoint curve will establish setpoint during these time frames with the setback (unoccupied) setpoint curve establishing setpoint for all other times. See the **Outdoor Reset** screen in **Setpoint**.

■ Trending

Trending data is continuously recorded by the control and can be enabled or disabled by the operator. Tap the "Next Curve" button to navigate through data types.

■ Admin

Administrative functions are used during initial commissioning, troubleshooting and other advanced tasks.

▶ SYSTEM CONFIGURATION

The System Configuration screen is used for saving (backup) and loading of program settings. The time and date is also configured on this screen. The backup battery status is shown in the bottom right of the screen. Loss of power without an operational battery will result in lost program settings.

▶ SENSOR STATUS

An overview of boiler and auxiliary sensor status is available on this screen.

▶ AUXILIARY CONFIGURATION

Through this screen, the system type, setpoint sources, sensors, vent material, and altitude are assigned. This must be individually configured for each boiler in the network.

▶ UNIVERSAL DATA CONFIGURATION

The Universal Data system allows the boilers to share vital data over the Ethernet/IP Boiler Network without having to wire individual sensors to each boiler, or write commands to each boiler. Configure the Universal Data sources at each boiler, for that specific boiler.

- Physically Wired – The control will look to its own I/O inputs for the information it needs and will then share that information with the Boiler Network.
- Boiler Network – The control will look to the local Ethernet/IP network for the information it needs. In order for this to work, one boiler will need to share that information with the network setup as either physically wired or BMS network.
- BMS Network – The control will look to the Building Management Network for the information that it needs and will share it with the rest of the boiler network.
- Please note that each signal/sensor can be independently configured, meaning one boiler could provide a setpoint to the boiler network, and another could provide the system header temperature, for instance.

▶ USER CONFIGURATION

An administrator password can be assigned to the control to prevent unauthorized access. The selected screens will require entry of the administrator password prior to access. The password may be up to 10 characters in length.



WARNING

All information in this manual is for reference and guidance purposes, and does not substitute for required professional training, conduct, and strict adherence to applicable jurisdictional/professional codes and regulations.

Non-Fulton product information is for reference purposes only. No Fulton document should substitute for full review of documentation available from the component manufacturer.

 **WARNING**

All information in this manual is for reference and guidance purposes, and does not substitute for required professional training, conduct, and strict adherence to applicable jurisdictional/professional codes and regulations.

Non-Fulton product information is for reference purposes only. No Fulton document should substitute for full review of documentation available from the component manufacturer.

Commissioning Mode

The boiler must be placed in commissioning mode prior to adjusting combustion parameters. This screen is intended for trained factory authorized technicians. This allows easy access to locking the SAS valve, and adjustments to %O₂ setpoint for the O₂ Compensation system at the firing rate ranges. Place the SAS Control into No Lock and tap the Complete Commissioning button when setup is fully completed to return to normal operation.

Perform Test of Limit Controls

Fire the boiler and test the high limit control as follows:

1. Alter high temperature limit to a value lower than the anticipated loop temperature. Turn the module on. Water temperature will rise until the module locks out. This condition has to be manually reset.
2. Alter the high limit cut off temperature to normal level, typically 10-20 degrees above set point.

Perform Test of Low Gas Pressure Switch

Test the low gas pressure switch as follows:

1. With the module running turn up the low gas pressure switch until a lock out is annunciated.
2. Return the switch to normal setting, re-start the boiler.

Perform Test of High Gas Pressure Switch

Test the high gas pressure switch as follows:

1. With the module running turn down the high gas pressure switch until a lock out is annunciated.
2. Return the switch to normal setting, re-start the boiler.

General Operation of the Boiler

Excessive cycling will reduce the useful life of any piece of mechanical equipment. Endura+ boilers should be operated and controlled so the boiler cycles less than 12,000 times per year.

INTRODUCTION

1

INSTALLATION

2

OPERATION

3

MAINTENANCE

4

SERVICE DOCUMENTS

5

WARNING

All information in this manual is for reference and guidance purposes, and does not substitute for required professional training, conduct, and strict adherence to applicable jurisdictional/professional codes and regulations.

Prior to any maintenance concerning electrical components of this equipment, ensure electrical supply to the equipment is disconnected. Label all wires prior to disconnection; wiring errors may cause improper and hazardous operation.

Follow all proper lockout/tagout procedures for service.

Before beginning any maintenance, ensure area is free of any combustible materials and other dangers.

*What to do if you smell gas:
Do not try to light the appliance.
Do not touch any electrical switch.
Do not use any phone in the building.
Leave building and contact gas supplier from neighbor's phone. If you cannot reach gas supplier, phone the fire department.*

After initial start-up by qualified personnel, linkage, control settings, and fuel pressures should not be readjusted.

CAUTION

All maintenance procedures should be completed by trained personnel. Appropriate training and instructions are available from the Fulton Service Department at (315) 298-5121 or your local Fulton Heating Solutions Representative.

In order to meet warranty conditions, ensure all appropriate maintenance activities are performed.

General

This boiler has been designed to provide years of trouble free performance. To ensure continued safety and efficiency of the boiler, please follow the maintenance and inspection directions outlined in this section of the manual.

Daily, Weekly and Monthly Maintenance and Inspection are considered good practice for any boiler, and is applicable to the full line of Endura+ boilers. It is also good practice for any boiler installation to perform a thorough review of the overall system on a regular basis, and after any maintenance procedures. Any potential issues should be noted and followed up on to ensure safety and reliability of all relevant equipment. System review items may include:

- Looking for discoloration of any painted equipment, boiler jacket panels, and/or insulation used in system piping.
- Carefully checking for gas leaks using a combustible gas detector during commissioning and regular inspections; a Gasmate® 0119 or equivalent is recommended. This includes, but is not limited to, gas delivery system, gas train fittings, pressure switches, gas valves, regulators, conduit connections to gas devices, and pre-mix delivery components.
- Looking for evidence of leaks including the air intake/exhaust systems, boilers, hydronic system piping, pumps, valves and other system components.
- Once boilers are running, making sure there are no flue gases around the boilers, or in the boiler room.

► *NOTE: Combustion analysis and adjustment schedule can vary based on boiler application and seasonal conditions. Biannual or quarterly adjustment may be optimal in some applications—for example, systems operating as both winter heat and summer reheat.*

Daily Maintenance and Inspection Schedule

Daily maintenance and inspection must include the following:

1. Observe operating temperature and general conditions.
2. Verify that the flow of combustion and ventilating air to the boiler is not obstructed.
3. Boiler area is free and clear of any combustible materials, including flammable vapors and liquids.

Weekly Maintenance and Inspection Schedule

Weekly maintenance and inspection must include the following:

1. Observe the conditions of each main flame. Correct fuel/air adjustment is essential for the efficient and reliable operation of this boiler. If an adjustment to the combustion is necessary, the flue gas composition should be checked with a carbon dioxide (CO₂) or oxygen (O₂) analyzer to set conditions.

Monthly Maintenance and Inspection Schedule

Monthly maintenance and inspection must include the following:

1. Test high-limit controls by reducing setting below the operating temperature; burner should shut off. After readjusting the setpoint, reset the control.
2. Test operating temperature controls by reducing temperature setting as necessary to check burner operation.
3. Check flue gas temperature at outlet. If there is a temperature increase over previous readings, the probable cause is soot or water-scale build-up on the tubes. Consult your Fulton Representative immediately if there is a concern.
4. Test each low gas pressure switch and high gas pressure switch utilizing the procedure in **Operation** section of this manual.
5. Inspect the combustion air inlet filters. If dust, lint or debris has accumulated such that the filter appears heavily loaded visually, replace the filter immediately.

Replacing the Combustion Air Inlet Filter

The combustion air inlet filters must be replaced at a minimum once per year. Active construction sites and installations with high airborne contaminants will require more frequent replacement.

Proceed as follows:

1. Remove the filter. The filter sits in the slot on the suction side of the blower inside the boiler cabinet.
 2. If debris has plugged or contaminated the filter, the filter must be replaced.
- **NOTE:** Operating the burner with the combustion air inlet filter removed will void the burner warranty. A clean filter of the same Fulton part number (type, size and style) must be installed while the boiler is in operation.
3. Return the filter to its original position in the slot, verify orientation.

Replacing or Updating the Boiler Control

Only update the software or firmware when directed by the factory. Lead/Lag integration requires the same firmware and software version on all units.

It is recommended to always update to the latest software when commissioning new boilers.



WARNING

All information in this manual is for reference and guidance purposes, and does not substitute for required professional training, conduct, and strict adherence to applicable jurisdictional/professional codes and regulations.

Never use open flame or other sources of ignition to check for gas leaks.

Ensure boiler is off and cooled with proper lockout-tagout per local codes prior to service and maintenance.



CAUTION

Use caution when using any cleaning solutions. Refer to local regulations for proper cleaning solution disposal.

Do not allow oil leaks, dust, or dirt to accumulate around the boiler.

WARNING

Personnel performing burner assembly maintenance must wear appropriate respiratory protection. Failure to do so may result in the inhalation of refractory ceramic fibers.

CAUTION

All information in this manual is for reference and guidance purposes, and does not substitute for required professional training, conduct, and strict adherence to applicable jurisdictional/professional codes and regulations.

All maintenance procedures should be completed by trained personnel. Appropriate training and instructions are available from the Fulton Service Department at (315) 298-5121 or your local Fulton Heating Solutions Representative.

In order to meet warranty conditions, ensure all appropriate maintenance activities are performed.

Burner gaskets must not be reused. Gaskets are designed for one-time use only.

Using nuts and washers not provided by Fulton can lead to flue gas leakage and cause damage to the studs.

Follow proper safety precautions when using a ladder.

Annual Maintenance and Inspection Schedule

Annual maintenance and inspection must be performed prior to each heating season, and includes but is not limited to the following tasks, which must be done by a factory trained technician:

1. Inspect each fuel train, burner and control panel to be sure components are free of debris and are properly attached to the boiler.
2. Replace each combustion air inlet filter with a new filter of the same Fulton part number (type, size and style).
3. Inspect flexible premix couplings; replace immediately if damaged or worn.
4. Examine the venting system (air intake and exhaust piping):
 - Check all joints and pipe connections for tightness.
 - Check piping for corrosion or deterioration.
 - Check that the piping is clear of debris.
 - Check that the condensate drain system is functioning.
5. Inspect the hydronic heating system for other problems.
6. Leak test the gas valves.
7. Clean the low water cut-out probe located on each module.
8. Remove and inspect each burner. Clean as necessary. See **Removing, Inspecting and Cleaning Burner** section of this manual.
9. Test each relief valve per manufacturer instructions by lifting the lever for 5 seconds and allowing the valve to snap shut. Please see the manufacturer's recommendations on the relief valve tag.
10. Perform combustion analysis on each module and adjust if necessary. A low O₂ level, resonance or harmonic can indicate a need for burner service.
11. Replace each oxygen sensor with a new sensor. Press "Reset O₂" on the Maintenance screen.

O₂ Compensation Measurement

The Fulton authorized service technician's gas analyzer measures O₂% after flue gas moisture removal, while the boiler O₂ sensor measurement is made without removal of the moisture. For operator convenience, the boiler O₂ sensor "wet" value is approximated to a "dry" value for control screen display purposes. This approximation may deviate from the test apparatus; the compared values should be within $\pm 1.0\%$ O₂. Discrepancies may be observed if the technician's gas analyzer has not been properly calibrated per manufacturer instructions and time interval.

► **NOTE:** THE O₂ COMPENSATION READOUT IS NOT A REPLACEMENT FOR A CALIBRATED FLUE GAS ANALYZER. The O₂ Compensation readout value must never be used for combustion adjustment and verification; a calibrated flue gas analyzer is required.

Removing, Inspecting and Cleaning Burner

For the following procedure, reference Figure 24.

1. Remove power and turn off the gas supply. Allow the boiler to cool.
2. A burner maintenance parts kit is required to complete the following steps. Contact your Fulton representative to purchase this parts kit before proceeding, please have your National Board number ready to expedite service.
3. Access to the burner is provided through the front cabinet door.
4. Loosen the hose clamps on flexible couplings and remove the premix elbow.
5. Remove safety and control devices from the burner flange, including the ignition assembly, UV flame scanner, and O₂ bypass line.
6. Loosen and remove the nuts and washers from the burner flange. Take care to properly handle and store the hardware during maintenance.
 - **NOTE:** Due to unique hardware specifications, alternate hardware must not be substituted. If hardware is lost or damaged, contact your Fulton representative for replacements.
7. Carefully remove the burner from the combustion chamber and cabinet, taking precaution to ensure the burner metal fiber material does not make contact with any other surfaces.
 - **NOTE:** Do not use liquids or brushes when cleaning the burner.
8. Visually inspect the interior and exterior of the burner for debris. If debris is present, use a compressed air blow gun with air pressure of 30 psi (2 bar) to maximum 72.5 psi (5 bar). The blow gun must be a minimum 0.40 inches (1 cm) from the surface of the burner. Carefully vacuum debris from the inside of the burner.
 - **NOTE:** The combustion air supply must meet the requirements detailed in the Installation section. Combustion air contaminants can lead to excessive maintenance or damage to burner components. The MERV 8 filter will capture 90+% of particles from 3-10 microns, but a small percentage will pass through to the burner head. Installations with poor combustion air quality may require burner cleaning more frequently than the annual service. A dirty burner may experience audible combustion harmonics within the normal operating range, requiring a need for cleaning. Damage due to poor combustion air quality is not covered under the warranty. A damaged burner will require replacement.
9. Carefully reinstall the burner: Replace both burner gaskets, do not reuse the burner gaskets. Apply C5-A Antiseize (PN [2-12-000191](#)) to threads, and reinstall the burner flange washers and nuts using only originally supplied or genuine Fulton replacement hardware. Tighten in a star pattern.
 - Verify torque to 20, 40, then 45-lbs. in three stages. A 6-point 7/8" crowfoot socket wrench is required.

WARNING

Specified torque values are mandatory to ensure safe and reliable operation of the boiler. Failure to properly torque hardware may result in PERSONAL INJURY, DEATH, or property damage.

O₂ bypass line is hot; contact with flammable materials can cause a fire. Do not touch or work on the O₂ system while hot.

THE O₂ COMPENSATION READOUT IS NOT A REPLACEMENT FOR A CALIBRATED FLUE GAS ANALYZER. Under no circumstances should the O₂ compensation readout value be used for combustion adjustment and verification; a calibrated flue gas analyzer is required.

Heat blocks, such as on the UV Scanner, must never be reused. If the heat block is removed it must be replaced. Use PTFE tape on the threads and properly tighten new heat block.

WARNING

THE O₂ COMPENSATION READOUT IS NOT A REPLACEMENT FOR A CALIBRATED FLUE GAS ANALYZER. Under no circumstances should the O₂ compensation readout value be used for combustion adjustment and verification; a calibrated flue gas analyzer is required.

10. Reinstall the ignition assembly with a new O-ring using Parker Super-O-Lube and apply C5-A Antiseize (PN [2-12-000191](#)) to screws.
 - Verify torque to 60 in-lbs.
- *NOTE: The ignition electrode on the pilot assembly requires annual inspection, but is not intended to be replaced on an annual basis. See [Inspecting the Pilot Ignition Assembly](#).*
11. Reinstall the oxygen sensor and verify torque to 26-33 ft-lbs. Reconnect the oxygen bypass line. Ensure sensor wiring cannot contact the bypass line.
 - *NOTE: The oxygen sensor is intended to be replaced annually. Sites with air contaminants such as silicone/RTV use in the boiler room may require more frequent replacement due to sensor poisoning. Use of "sensor safe" silicones/RTV is required. Sites running propane fuel and/or year-round such as for summer reheat may require biannual replacement.*
12. Replace the scanner heat block with new using PTFE tape on the metal threads only. Do not use PTFE tape on the heat block threads. Reinstall and hand tighten the UV scanner.
13. Reinstall pre-mix elbow flexible coupling and tighten hose clamps using hand tools only. Never tighten hose clamps with power tools.
 - Verify torque to 45 in-lbs.
14. Reinstall cabinet panels.
15. Perform a full combustion analysis and adjust if necessary.

Inspecting the Pilot Ignition Assembly

- *NOTE: The pilot assembly requires annual inspection; although it is considered a wear-item it is not intended to be replaced on an annual basis.*
1. Remove the pilot ignition assembly from the burner flange.
 2. Inspect for corrosion in the raja connector on the pilot and on the ignition wire. Replace if found.
 3. Inspect insulator for cracks, dirt, oils or soot. Clean if necessary. Replace if any cracks are found or it cannot be cleaned.
 4. Verify that the pilot orifice is clean. Clean if obstructed.
 5. Verify that the spark gap to the tube is 3/16" (4.763 mm) within tolerance +/- 1/16" (1.588 mm), adjust if needed.
 6. Inspect that the insulation block around the pilot when installed has not lost structural integrity. Replace with original Fulton part if needed.
 7. Reinstall the pilot ignition assembly per the instructions detailed in **Removing, Inspecting, and Cleaning Burner**.

After All Repairs and Maintenance

1. Perform all Safety Checks as described in the **Operation** section.
 2. Fire the boiler and perform a full combustion verification. Make adjustments as necessary.
 3. Complete the "Installation and Operation Report" for Endura+ boilers and retain in the boiler's maintenance records.
- *NOTE: Accurate and complete combustion and maintenance records detailing compliance with the Installation, Operation and Maintenance Manual must be produced for warranty consideration.*

Bill of Material		
Item	Part Number	Description
1	2-12-000012	3/4"NPT Sight Observation Port
2	2-12-000721	029 1/16"Viton O-Ring 1.625 OD
4	2-12-315008	2"ID x 6" Neoprene Flexible Coupling
6	2-12-315011	EDR+ 6000 Premix / Furnace Gasket
25	2-22-000058	1/2-13 Hex Nut, GR. 2H
34	2-22-315006	2" - 3" Steel Worm Drive Hose Clamp
41	2-22-315039	1/2" Belleville Washer (SS301, 0.519"ID x 1.24"OD x 0.125"THK)
42	2-22-315040	1/4-20 x 5/8" Long S.S. Torx Screw
70	2-40-000464	3/4" - 14 NPSM Thermal Barrier for Flame Detector
73	2-40-001107	Siemens LMV2-3 High Sensitivity UV Scanner
76	2-40-315600	EDR+6000 Mesh Burner
89	2-45-315501	O2 Sensor
95	5-10-315310	250 Hz Resonator Capped Tube
96	5-10-315315	EDR+6000 Burner Volume Reducer/Premix Inlet Assembly
107	5-10-315675	EDR+6000 Premix Retainer Plate
110	5-10-315680	EDR+6000 Pilot Assembly
119	5-10-315694	EDR+6000 Pilot Insulation

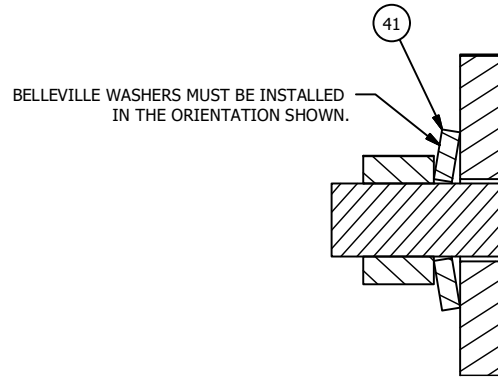

WASHER ORIENTATION DETAIL
(SHOWN PRETORQUE FOR CLARIFICATION)

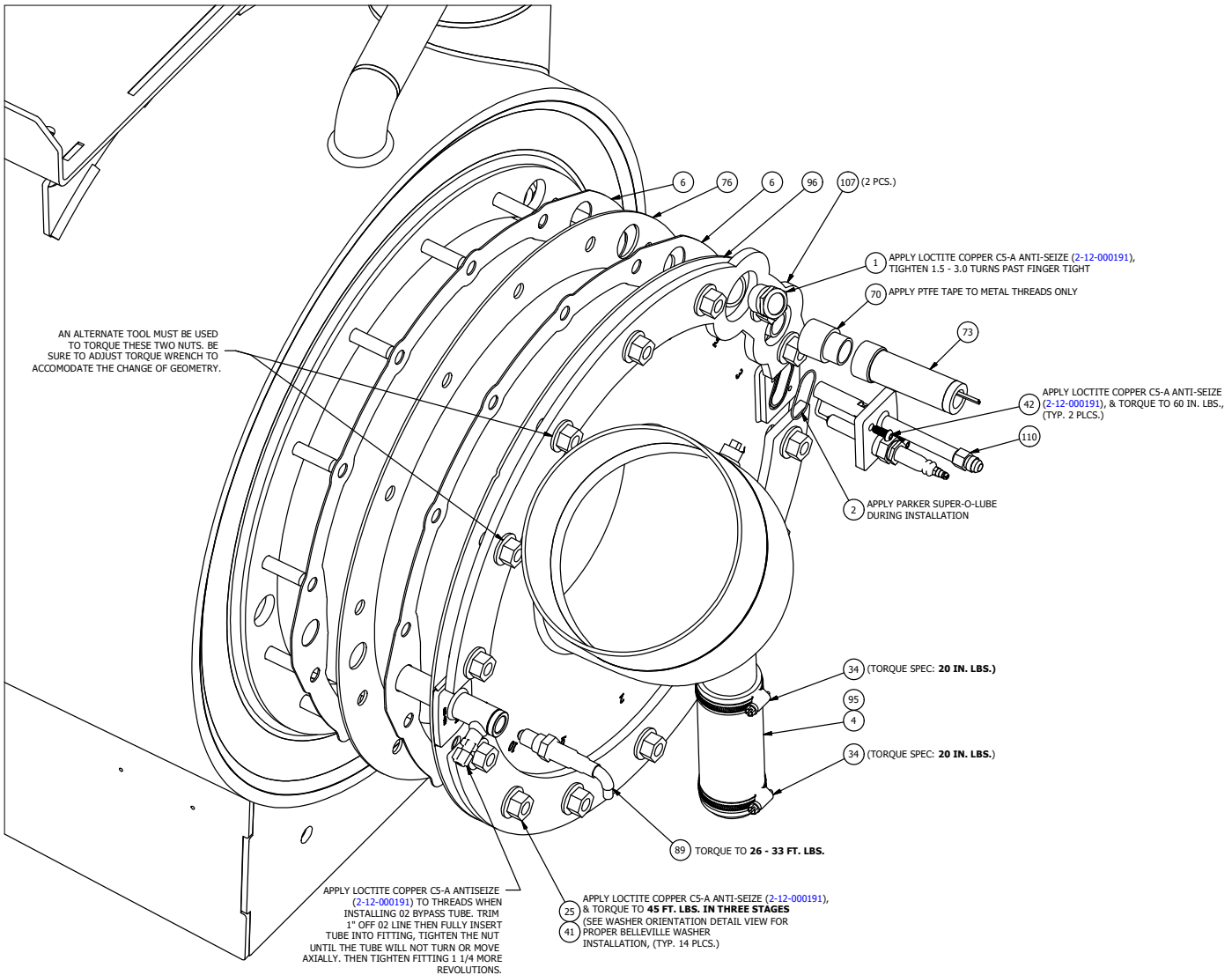

FIGURE 24 - BURNER ASSEMBLY

THIS PAGE LEFT INTENTIONALLY BLANK

Troubleshooting

Use the following tables as a guide to troubleshooting your boiler.

PROBLEM	CAUSE	CHECK
Boiler Will Not Start	Controller/Settings	<p>Check for active alarms. Investigate and address root cause and reset as necessary.</p> <p>Navigate to the Boiler Status screen from the Boiler Control menu. Check the following:</p> <ul style="list-style-type: none"> Boiler Status at the top of the screen. This status is directly from the flame safeguard and may indicate why the boiler will not start. "Call for Heat" is displayed on top right corner of display. What is in control of the boiler? This is shown at "Control:" and could be Local, Lead/Lag or Manual. Verify supply water or boiler outlet temperature versus boiler setpoint. Navigate to the Universal Data screen from the Admin menu to verify if the boiler is setup to operate from a system supply sensor or the boiler outlet sensor. <p>Navigate to the Safety Device Status screen from the Boiler Control menu:</p> <ul style="list-style-type: none"> If there is any device that does not have a green light next to it, the boiler will not run. If all safeties are green and there is no call for heat, check the boiler setpoints and on/off hysteresis. <p>Navigate to the Operator Control screen from the Boiler Control menu:</p> <ul style="list-style-type: none"> Ensure that the boiler is not disabled. Manually starting the boiler from this screen could be attempted. Verify whether the boiler Anti-Cycle is enabled as it may be holding the boiler off.
Nuisance Manual Reset High Temperature Limit Lockouts	Controller/Settings	<p>Verify the setting on the mechanical Manual Reset High Limit (MRHL) device, it must always be higher than the sum of the temperature setpoint plus off hysteresis value. The factory recommended setting is 200°F.</p> <p>Check the supply temperature setpoint setting parameter in the boiler control or Building Management System setpoint signal where applicable. The closer the setpoint setting is to the MRHL setting, the higher the likelihood of a lockout.</p>
	Installation	<p>Verify balancing valves (if used) have been properly commissioned.</p> <p>For modular boiler plants, ensure piping is configured reverse return where the first boiler in is the last boiler out. If the piping configuration is not reverse return, balancing valves should be installed and properly commissioned to ensure each boiler is receiving relatively equal water flow.</p> <p>Verify the boiler is receiving enough flow at the current heat demand for the given hydronic fluid type and desired delta-T. This can be calculated using the $Q = m \times cp \times \Delta T$ heat transfer equation. See the Fulton "Calculating Flow Rate" Engineering Guide for more details. If calibrated flow meters are not available, flow rate can be approximated by recording differential pressure across a balancing valve or by referencing the pump curve.</p>

PROBLEM	CAUSE	CHECK
No Power to Controls	Electrical/Wiring	<p>Check fusing and replace as necessary.</p> <p>Measure incoming voltage to boiler is in compliance with requirements and stepdown transformer output is 120VAC.</p> <p>Verify control power supply voltage at PS1 (24 VDC) and PS2 (12 VDC).</p> <p>Verify power plugs are fastened securely to control devices.</p> <p>Verify wiring between terminal blocks, power supplies and control devices.</p>
Low Flow Alarm	Installation	<p>This alarm condition means the system is not providing adequate flow, causing the boiler to exceed its Delta-T limit more than 5 times in a 30-minute period.</p> <p>Verify Delta-T on Boiler Status screen. For default settings, the boiler may not exceed 40°F Delta-T above 30% firing rate. Below 30%, the maximum Delta-T will scale with firing rate as the minimum flow rate is not being met. See Table 1.</p> <p>Verify balancing valves (if used) are properly balanced.</p> <p>Verify pumps are operating properly and providing proper flow.</p> <p>Inspect hydronic strainers. Verify “startup screens” have been removed from the strainers. Clean strainer filter if clogged or dirty</p>
	Maintenance/Safeties	<p>Verify boiler isolation valves are fully opened on active boilers and closed for idle boilers.</p> <p>Verify that pumps are running at a speed to maintain boiler Delta-T and required minimum flow specified in Table 1.</p>
High Back Pressure Switch Trips	Installation	<p>Measure draft pressure at the flue gas outlet of the boiler during pre-purge, steady-state high fire, and post-purge conditions. The measurement must not exceed the maximum value listed in Table 4. If the stack pressure is exceeded, remove flue rain caps or velocity cones (if installed) and measure again.</p> <p>Verify vent is immediately upsized at the boiler using an eccentric increaser or elbow listed in Table 7 to the minimum flue diameter specified in Table 1.</p> <p>Verify the venting is pitched back towards the boiler flue gas outlet.</p> <p>Inspect boiler and stack condensate drains and ensure there are no obstructions or debris that would prevent free drainage.</p> <p>Inspect the horizontal venting sections for low spots. There must not be any low spots in the flue gas vent.</p> <p>Inspect venting for internal obstructions to proper condensate drainage such as excessive use of RTV, undersized gaskets or debris.</p> <p>Consider adding additional condensate drains in the flue or an in-line vertical drain directly above the boiler flue gas outlet.</p>
	Maintenance/Safeties	<p>Exhaust backpressure switch is set to trip at +2.0”W.C. and is not adjustable. Verify that the stack pressure does not exceed the values listed in Table 4.</p>

PROBLEM	CAUSE	CHECK
VFD Speed Error/Fault	Controller/Settings	<p>Verify that the fault is being logged in the PURE Control™ alarm history. Record the code, diagnostic, phase and firing rate at which the fault(s) occurred.</p> <p>Check for any fault codes on the VFD.</p> <p>Verify that the cooling fan in the bottom of the VFD is operational.</p> <p>Verify LMV parameters below:</p> <ul style="list-style-type: none"> • Parameter 211 set to 20 (fan ramp up time) • Parameter 522 set to 10 (ramp up VSD) • Parameter 523 set to 15 (ramp down VSD) <p>Verify VFD parameters below:</p> <ul style="list-style-type: none"> • Parameter 109 set to 8 (acceleration time) • Parameter 110 set to 8 (deceleration time) <p>Verify that the combustion curve air positions do not change more than 10° from point to point. From the alarm history, verify which phase and firing rate the fault is occurring at; check the air positions at this phase.</p>
	Electrical/Wiring	<p>Verify both voltage and frequency. Voltage measurement must be within the specifications detailed in Electrical Connections and Devices in the Installation section.</p> <p>Verify speed sensor electrical connections.</p> <p>Verify that the speed sensor is adjusted 2 turns (1/16") from the flag on the speed wheel. Blower motor re-standardization will be required when adjusting speed sensor. Once standardization is completed, verify combustion settings.</p> <p>Verify all three-phase wiring coming in to the boiler as well as to and from the fusing, VFD and blower motor. Ensure terminations are snug and are not tightened down on wire casing.</p> <p>Verify 120VAC relay operation (CR05) and that it is not dropping out at any time.</p>
Oxygen Sensor Value Does Not Match Combustion Analyzer	Maintenance/Calibration	<p>The Fulton authorized service technician's gas analyzer measures O2% after flue gas moisture removal, while the boiler O2 sensor measurement is made without removal of the moisture. For operator convenience, the boiler O2 sensor "wet" value is approximated to a "dry" value for control screen display purposes. This approximation may deviate from the test apparatus; the compared values typically be within ±1.0% O2. Discrepancies may be observed if the technician's gas analyzer has not been properly calibrated per manufacturer instructions and time interval.</p>
Oxygen Sensor Alert	Maintenance	<p>Replace Oxygen sensor on an annual basis. Sites with air contaminants such as silicone, RTV and halogen and sulfur compounds may require more frequent replacement.</p>
	Controller/Settings	<p>Verify with Fulton technical support that the latest software version is installed on the PURE Control™.</p>
	Installation	<p>Verify that there is no air contamination or flue gas recirculation. Verify any silicone used near the boiler or combustion air supply is labeled "Sensor Safe".</p>

PROBLEM	CAUSE	CHECK
LED Illuminated on SAS Actuator	Maintenance/Safeties	<p>See below for LED meaning:</p> <ul style="list-style-type: none"> • Green (steady) - Automatic Mode; Normal operation • Green (blinking) - Calibration or Manual Mode; Wait until calibration has finished or manual adjuster is in MAN position • Red (steady) - Calibration error or Undervoltage (13VAC); Start calibration again or check operating voltage • Red (blinking) - Clogged valve, detection of foreign bodies; Check valve/actuator • Dark (no illumination) - No power or electronics faulty; Check operating voltage <p>Verify the SAS actuator is not binding or being hindered from rotating. Refer to Service Bulletin FHS-2019-001SVB for additional instruction.</p> <p>Inspect the head and ensure it is pulled out for Auto operation (push in and rotate for manual).</p>
Boiler Excessively Cycling	Controller/Software	<p>Consult Fulton technical support to verify the latest software version is installed on the PURE Control™.</p> <p>Verify boiler is configured for automatic operation.</p> <p>Verify temperature setpoint and on/off hysteresis settings are appropriate at each boiler. A tighter hysteresis band will increase cycling, relax (increase) this band to reduce cycling.</p> <p>Verify PID settings are appropriate for boiler application. Note that there are different PID settings for Local and for Lead/Lag operation. Verify these settings are correct and matching on each boiler installed.</p> <p>If a Building Automation is commanding temperature setpoint to the boiler(s), ensure that any setpoint changes are infrequent and slowly stepped in small increments/decrements. Rapid changes in temperature setpoint may cause boiler short cycling.</p>
CPU Error Displayed	Electrical/Wiring	<p>Remove the access panel on the rear of the front cabinet door and verify all modules clipped into the back of display are fastened completely and securely. Replace CPU module and/or display.</p>
Temperature(s) Not Displaying Properly	Controller/Settings	<p>If update was just performed, verify the correct software type (old hardware versus new hardware) was installed.</p>
	Electrical/Wiring	<p>If all temperatures are not displaying properly, verify all expansion modules are communicating and that Link and Power LEDs are illuminated green.</p> <p>Verify wiring to and from appropriate I/O modules.</p> <p>Verify temperature sensor operation.</p> <p>Replace sensor wiring on I/O module with a known working sensor to determine possibility of bad sensor or bad I/O module.</p>

PROBLEM	CAUSE	CHECK
UV Scanner Fault/Flame Out of Sequence	Installation	Verify that no sources of bright light can be picked up by the sensor through the sight glass.
	Electrical/Wiring	<p>Verify wiring and connection between the UV scanner and the flame safeguard.</p> <p>Remove and visually inspect the UV scanner. Verify that the scanner is not wet or damaged, and that there not any film or residue on the glass.</p> <p>Replace sensor with a known working sensor to see if the issue follows or replace with a new sensor.</p>
Pilot Issues/Boiler Not Lighting/Ignition Failure	Installation	<p>Ensure all gas cocks are open.</p> <p>Visually inspect through the sight glass to see if flame is present at light off.</p> <p>If flame is present at light off, verify UV scanner wiring and operation; replace scanner as needed.</p> <p>Measure draft pressure and ensure it is within the requirements of Table 4 and the intake/exhaust vent system adheres to all requirements as outlined in the Installation section.</p> <p>Verify the boiler room is at a neutral pressure relative to the outdoors.</p>
	Maintenance/Safeties	<p>Verify the pilot line has been fully purged.</p> <p>Verify proper gap on igniter assembly.</p> <p>Verify combustion settings at P0 in the flame safeguard.</p>
	Controller/Settings	<p>Consider increasing Parameter 186 in the LMV up to 30 for a flame failure response time of 3 seconds.</p> <p>Consider temporarily changing parameter 208 in LMV from 0 to 3 to hold the boiler at pilot. Check pilot. When finished verifying acceptable pilot flame, change parameter 208 back to zero.</p>
Errors During Program Update	Controller/Settings	<p>Refer to Section 4 Downloading A Program to The PLC of the PURE Control™ Addendum for issue regarding program updates.</p> <p>A 4GB or larger flash drive is required when performing a software update.</p> <p>If a "Version Mismatch: UniLogic/UniStream Firmware" screen is prompted while performing the program update, continue performing the update as outlined in Section 4 of the PURE Control™ Addendum.</p>
Touchscreen not Responding or Does Not Illuminate	Electrical/Wiring	<p>Cycle power to the boiler.</p> <p>Ensure the display is getting power (12VDC).</p>
	Controller/Settings	<p>Verify that the mounting clips are not over-tightened.</p> <p>Replace the display.</p>

PROBLEM	CAUSE	CHECK
No SD Card Error	Controller/Settings	<p>Install/Replace SD card with a capacity of 4GB or larger.</p> <p>Reference Installation and Operation Manual Pure Control™ Addendum for more information on SD card.</p>
Main Flame Failure	Maintenance	<p>Verify combustion parameters at all combustion points P1-P9. Correct as necessary.</p> <p>Verify sufficient supply gas pressure within the requirements of the data plate at the rear of the boiler. Ensure gas pressure does not drop more than 15% between static (idle) and dynamic (high fire).</p> <p>Verify manifold gas pressure is within the specified requirements. Refer to the factory Test Fire Report included with the boiler. Note: Test Fire Report parameters are used as a reference point, site conditions will ultimately dictate what parameters are appropriate for safe and reliable operation.</p> <p>Inspect burner, clean according to maintenance instructions if dirty.</p> <p>Inspect combustion air filter. Replace if dirty.</p> <p>Verify UV scanner wiring and operation; replace as needed.</p> <p>Using a monometer, measure the draft pressure at the boiler flue gas exhaust outlet connection during idle, trial for ignition, low fire and high fire. At all conditions the draft pressure must be within the limits specified in Table 4.</p> <p>Inspect the intake termination. Ensure it is not obstructed by ice, snow, or debris. Ensure the intake termination is not subjected to high wind.</p> <p>Inspect the flue gas exhaust termination. Ensure it is not obstructed by ice, snow, or debris. Ensure the flue gas exhaust termination is not subjected to high wind.</p> <p>Ensure flue gas recirculation (FGR) is not occurring by visually witnessing the interaction of the exhaust and intake terminations during boiler main flame run. FGR will be evidenced by a vapor plume in the immediate vicinity of the intake termination. If occurring, this must be immediately corrected.</p> <p>Possible solutions for FGR include:</p> <ul style="list-style-type: none"> • Removing the exhaust termination rap cap (if installed) • Installing an exhaust termination velocity cone • Increasing the height of the exhaust termination • Increasing the horizontal separation of the intake to the exhaust termination <p>Verify the boiler room is at a neutral pressure relative to the outdoors.</p> <p>Verify no other mechanical equipment intake or exhaust is installed near the boiler combustion air intake, such as other boilers, water heaters, air handling equipment, cogen units, and cooling towers.</p>

PROBLEM	CAUSE	CHECK
Burner Harmonic or Resonance	Maintenance	<p>Inspect air filter, replace if dirty.</p> <p>Verify combustion at all operating points.</p> <p>Inspect burner, clean according to maintenance instructions if dirty.</p> <p>Proceed to resonator adjustment ONLY AFTER verifying the above. Consult factory for resonator adjustment.</p>
High Water Temp Alarm(s)/ HLTC Limit Trips	Maintenance/ Safeties	<p>Ensure hysteresis off value plus temperature setpoint does not approach the manual reset temperature.</p> <p>Verify isolation valves are fully opened and operational.</p> <p>Verify pump operation and flow.</p>
VFD Manual Lockout After Power Outage	Settings	<p>A power outage greater than 15 seconds but less than 25 seconds can cause a VFD lockout condition. Reset the VFD lockout.</p> <p>Verify VFD parameters A451 = 5 and A452 = 5. See bulletin 2018-005SVB or contact Fulton technical support for additional instructions.</p>
Combustion Blower Noise after Periods of Idle	Low Utilization	<p>Fulton induction-motor premix combustion blowers are built to a high durability standard. To achieve such a long life in demanding conditions, a premium bearing system is used that utilizes high temperature rated grease. As a result, when the blower is under low utilization or remains idle for a long period of time, the grease can settle and in some cases noise can be heard from the motor when returning it to service.</p> <p>The noise is not a concern and will abate as the blower is run and the grease redistributed. Sounds are more common while the bearings are new and near the beginning of life.</p>
	Maintenance	<p>Use a vibration meter to record levels at various speeds including at low fire and high fire. Submit recorded data to Fulton Technical Support for evaluation. A Fluke® 810 or similar is recommended.</p> <p>Disconnect power, remove combustion air filter and air servo assembly. Turn the fan wheel by hand and inspect for resistance, noise, or foreign objects inside the housing.</p>

INTRODUCTION

1

INSTALLATION

2

OPERATION

3

MAINTENANCE

4

SERVICE DOCUMENTS

5

PAGE INTENTIONALLY LEFT BLANK



PRE-COMMISSIONING INSTALLATION CHECKLIST

NOTE:
TO BE COMPLETED BY INSTALLING CONTRACTOR.

DATE	
CONTACT NAME	
BOILER MODEL	

JOB SITE NAME	
PHONE NUMBER	
BOILER NB/SERIAL #(s)	

ELECTRICAL & COMMUNICATION:

Electrical wiring to the boiler terminated and tested?	<input type="checkbox"/> YES	<input type="checkbox"/> NO	
Voltage matches the data plate on the rear of the boiler?	<input type="checkbox"/> YES	<input type="checkbox"/> NO	
Control wiring for lead/lag is terminated and tested?	<input type="checkbox"/> YES	<input type="checkbox"/> NO	<input type="checkbox"/> N/A
Building automation wiring is terminated and tested?	<input type="checkbox"/> YES	<input type="checkbox"/> NO	<input type="checkbox"/> N/A

SYSTEM PIPING

All hydronic piping to the boiler is completed and leak tested?	<input type="checkbox"/> YES	<input type="checkbox"/> NO	
All hydronic piping has been fully flushed? <i>Note: Chemical cleaning must bypass the boiler; clean water flush must have strainers at the boiler inlet</i>	<input type="checkbox"/> YES	<input type="checkbox"/> NO	
Circulating pumps are wired, tested, and ready for operation?	<input type="checkbox"/> YES	<input type="checkbox"/> NO	
Motorized boiler isolation valves are wired, tested, and fully operational?	<input type="checkbox"/> YES	<input type="checkbox"/> NO	<input type="checkbox"/> N/A

FLUE GAS EXHAUST VENT AND COMBUSTION AIR INTAKE:

Flue vent meets material type and requirements detailed in the IOM?	<input type="checkbox"/> YES	<input type="checkbox"/> NO	
Flue and combustion air terminations meet minimum separation requirements and are installed to prevent flue gas recirculation?	<input type="checkbox"/> YES	<input type="checkbox"/> NO	
Condensate drain is completed and meets IOM installation requirements?	<input type="checkbox"/> YES	<input type="checkbox"/> NO	
Combustion air louvers meet minimum SQFT detailed in IOM?	<input type="checkbox"/> YES	<input type="checkbox"/> NO	<input type="checkbox"/> N/A
Mechanical draft controls are powered, tested, and fully operational?	<input type="checkbox"/> YES	<input type="checkbox"/> NO	<input type="checkbox"/> N/A

FUEL PIPING

Supply gas piping and regulators are properly sized to ensure adequate gas supply under all operating conditions? (Idle, Light Off, High Fire, etc.)	<input type="checkbox"/> YES	<input type="checkbox"/> NO	
Use a manometer to measure the gas pressure at the fuel train inlet:	_____ INCHES WC		
Does the measured gas pressure meet the requirement listed on the data plate on the rear of the boiler?	<input type="checkbox"/> YES	<input type="checkbox"/> NO	
Gas vents are individually run, properly upsized every 10 feet, and terminated to atmosphere if required by Authority Having Jurisdiction?	<input type="checkbox"/> YES	<input type="checkbox"/> NO	<input type="checkbox"/> N/A
Gas regulators installed minimum 10 feet of pipe from the boilers?	<input type="checkbox"/> YES	<input type="checkbox"/> NO	<input type="checkbox"/> N/A

SITE SIGN-OFF	
PRINT NAME	

DATE:	
TITLE:	

When complete, return a copy to your Fulton Representative and/or the service organization performing commissioning ("start-up") services.

PAGE INTENTIONALLY LEFT BLANK



INSTALLATION & OPERATION
"START-UP" REPORT

NOTE:

TO BE COMPLETED BY A FACTORY AUTHORIZED TECHNICIAN HOLDING A VALID EDR+ CERTIFICATE OF REGISTRATION. WARRANTY COVERAGE IS VALID ONLY IF THIS FORM IS SUCCESSFULLY COMPLETED AND RETURNED TO FULTON WITHIN TWELVE WEEKS OF START-UP.

DATE	FULTON REP.
TECHNICIAN	CUSTOMER
TECH. COMPANY	CONTACT NAME
TECH CERTIFICATE #	CITY, STATE
BOILER MODEL	PHONE NUMBER
NATIONAL BOARD #'S	E-MAIL

GENERAL:

Boiler room pressure (Note: Must be neutral pressure)	_____ INCHES WC
Condensate trap height	_____ INCHES
Is the boiler configured for internal lead lag?	<input type="checkbox"/> YES <input type="checkbox"/> NO
Boiler set point source (i.e. BMS, OAT, 4 - 20ma, Static)	_____
Does the Hydronic System contain glycol?	<input type="checkbox"/> _____% <input type="checkbox"/> NONE
What is the boiler water pressure? (Note: glycol 30psi minimum)	_____ PSI
Update PURE Control™ to latest software version	VERSION: _____

COMBUSTION AIR SUPPLY FROM BOILER ROOM ONLY:

If boiler room, what is the Upper Louver Size? (In inches)	LENGTH _____ HEIGHT _____
If boiler room, what is the Lower Louver Size?	LENGTH _____ HEIGHT _____
Combustion air louver type	<input type="checkbox"/> FIXED <input type="checkbox"/> MOTORIZED
If motorized, are they interlocked with the boilers?	<input type="checkbox"/> YES <input type="checkbox"/> NO <input type="checkbox"/> N/A

COMBUSTION AIR SUPPLY DUCTED DIRECTLY TO BOILER ONLY:

Combustion air intake material type (ie: PVC, Spiral Metal Duct, etc.)	: _____
Air intake termination location	<input type="checkbox"/> ROOFTOP <input type="checkbox"/> SIDEWALL
Intake configuration	<input type="checkbox"/> INDIVIDUAL <input type="checkbox"/> COMMON
Combustion air intake ducting diameter	_____ INCHES
Combustion air intake ducting length	_____ FEET
Combustion air intake elbow quantity	45'S _____ 90'S _____
Horizontal separation between intake and exhaust termination	_____ FEET
Vertical separation between intake and exhaust termination	_____ FEET

FLUE GAS EXHAUST VENT CONFIGURATION:

Flue Gas Exhaust Venting (ie: CAT II/IV, AL29 - 4C, Polypropylene or 316L SS)	_____
Exhaust termination location	<input type="checkbox"/> ROOFTOP <input type="checkbox"/> SIDEWALL
Exhaust configuration	<input type="checkbox"/> INDIVIDUAL <input type="checkbox"/> COMMON
Venting inside diameter	_____ INCHES
Total Venting length (Rise + Run)	_____ FEET
Vertical rise only	_____ FEET
Elbows quantity	45'S _____ 90'S _____
If common vented, is an exhaust fan installed?	<input type="checkbox"/> YES <input type="checkbox"/> NO
What Is The Set Pressure Of The Fan?	_____ INCHES WC
Common vent pressure with all the boilers on at...	HIGH FIRE _____ LOW FIRE _____
Does the boiler have a modulating draft damper?	<input type="checkbox"/> YES <input type="checkbox"/> NO
Does the common exhaust have a modulating draft damper?	<input type="checkbox"/> YES <input type="checkbox"/> NO

MODULE 1

SAFETY CHECKS: Check all safeties below for proper operation and document the final settings.

DEVICE	SETTING	OPERATIONAL
Low Water Safety		
Air Switch		
Low Gas Pressure Switch		
High Gas Pressure Switch		
Proof of Closure (POC)		
Blocked Flue Switch		

DEVICE	SETTING	OPERATIONAL
Air Filter Switch		
High Temperature Limit		
Temperature Controller		
Fuel Train Leak Test		
Blower Leak Test		

MODULE 2

SAFETY CHECKS: Check all safeties below for proper operation and document the final settings.

DEVICE	SETTING	OPERATIONAL
Low Water Safety		
Air Switch		
Low Gas Pressure Switch		
High Gas Pressure Switch		
Proof of Closure (POC)		
Blocked Flue Switch		

DEVICE	SETTING	OPERATIONAL
Air Filter Switch		
High Temperature Limit		
Temperature Controller		
Fuel Train Leak Test		
Blower Leak Test		

MODULE 1

COMBUSTION SETTINGS: Fuel Type is Natural Gas

FIRING POSITION:	P0 LIGHT	P1	P2	P3	P4	P5	P6	P7	P8	P9 100%
Fuel Position AZL										
Air Position AZL										
VFD Position AZL										
VFD Hertz										
VFD Ampere										
Supply Gas Pressure (InWC)										
Manifold Gas Pressure (InWC)										
MV Downstream Gas (InWC)										
Fan Discharge Pressure (InWC)										
Wet (Stack Analyzer) O2%										
Dry (Burner Sensor) O2%										
CO2 %										
CO ppm										
NOx @ 3%										
Excess Air %										
Room Ambient Temp. °F										
Combustion Air Temp. °F										
Stack Temperature °F										
Stack Draft (InWC)*										
Inlet Water Temp. °F										
Outlet Water Temp. °F										
Main Flame Signal										
Pilot Flame Signal**										

* Use only a Slack Tube® Manometer or equivalent. The use of a digital manometer is not recommended.

** Where applicable

MODULE 2

COMBUSTION SETTINGS: *Fuel Type is Natural Gas*

FIRING POSITION:	P0 LIGHT	P1	P2	P3	P4	P5	P6	P7	P8	P9 100%
Fuel Position AZL										
Air Position AZL										
VFD Position AZL										
VFD Hertz										
VFD Ampere										
Supply Gas Pressure (InWC)				XXXX	XXXX	XXXX	XXXX	XXXX	XXXX	
Manifold Gas Pressure (InWC)				XXXX	XXXX	XXXX	XXXX	XXXX	XXXX	
MV Downstream Gas (InWC)				XXXX	XXXX	XXXX	XXXX	XXXX	XXXX	
Fan Discharge Pressure (InWC)										
Wet (Stack Analyzer) O2%										
Dry (Burner Sensor) O2%										
CO2 %										
CO ppm										
NOx @ 3%										
Excess Air %										
Room Ambient Temp. °F		XXXX	XXXX	XXXX	XXXX	XXXX	XXXX	XXXX	XXXX	
Combustion Air Temp. °F		XXXX	XXXX	XXXX	XXXX	XXXX	XXXX	XXXX	XXXX	
Stack Temperature °F										
Stack Draft (InWC)*										
Inlet Water Temp. °F										
Outlet Water Temp. °F										
Main Flame Signal										
Pilot Flame Signal**		XXXX	XXXX	XXXX	XXXX	XXXX	XXXX	XXXX	XXXX	XXXX

* Use only a Slack Tube® Manometer or equivalent. The use of a digital manometer is not recommended.

** Where applicable

OPERATING HISTORY (SIEMENS LMV3) :

P-161 Total Faults	
P-162 Operating Hours	
P-166 Number of Startups	

When complete, please keep this form with the boiler, store a copy in a safe location and return a copy to Fulton:

The Fulton Companies
ATTN: FHS Service Coordinator
972 Centerville Road
Pulaski, New York 13142

Phone: (315) 298-5121 • Fax: (315) 298-6390

NOTE: *Submission of this report is not an acceptance or approval of the technician's work and recorded data. Recieved reports will be filed but may not be reviewed by technical service.*

PAGE INTENTIONALLY LEFT BLANK



ANNUAL MAINTENANCE CHECKLIST

NOTE:

TO BE COMPLETED BY A FACTORY AUTHORIZED TECHNICIAN HOLDING A VALID EDR CERTIFICATE OF REGISTRATION.

DATE	
TECHNICIAN	
TECH. COMPANY	

TECH CERTIFICATE #	
BOILER MODEL	
NATIONAL BOARD #'S	

ANNUAL MAINTENANCE:

Burner head removed and visually inspected	<input type="checkbox"/>	COMPLETE
Burner head cleaned (30-72.5 psi air only)	<input type="checkbox"/>	COMPLETE
Burner head reinstalled with new gaskets	<input type="checkbox"/>	COMPLETE
Burner flange hardware torqued to spec (see Section 4 of IOM)	<input type="checkbox"/>	COMPLETE
Low water probe(s) removed, cleaned, and reinstalled	<input type="checkbox"/>	COMPLETE
Combustion air inlet filter replaced with new	<input type="checkbox"/>	COMPLETE
Direct spark ignition replaced with new (where applicable)	<input type="checkbox"/>	COMPLETE
Oxygen sensor replaced with new, Reset O2, and Set Initial O2 performed	<input type="checkbox"/>	COMPLETE
PURE Control software/firmware update installed (where directed)	<input type="checkbox"/>	COMPLETE
Special gas vent system and condensate drains inspected	<input type="checkbox"/>	COMPLETE
Combustion air intake inspected	<input type="checkbox"/>	COMPLETE
Safety relief valve tested, replace if it does not fully reseal	<input type="checkbox"/>	COMPLETE
Flexible premix couplings inspected, replace immediately if worn	<input type="checkbox"/>	COMPLETE
Open factory Service Bulletin(s) addressed (where applicable)	<input type="checkbox"/>	COMPLETE
Safety checks table completed		(fill in tables below)
Combustion verification completed, adjust as necessary		(fill in tables on reserve side)

WATER CHEMISTRY: Verify water chemistry is within specific limits, correct where required.

pH (8.5-10.5)	_____
Oxygen (<250 ppb)	_____ ppb
Iron/Copper (<5 ppb)	_____ ppm
Chloride (<200 ppb)	_____ ppm
Hardness (<60 ppm)	_____ ppm
Glycol % (Maximum 50%, glycol systems require 30 psi minimum)	_____ %

MODULE 1

SAFETY CHECKS: Check all safeties below for proper operation and document the final settings.

DEVICE	SETTING	OPERATIONAL
Low Water Safety		
Air Switch		
Low Gas Pressure Switch		
High Gas Pressure Switch		
Proof of Closure (POC)		
Blocked Flue Switch		

DEVICE	SETTING	OPERATIONAL
Air Filter Switch		
High Temperature Limit		
Temperature Controller		
Fuel Train Leak Test		
Blower Leak Test		

MODULE 2

SAFETY CHECKS: Check all safeties below for proper operation and document the final settings.

DEVICE	SETTING	OPERATIONAL
Low Water Safety		
Air Switch		
Low Gas Pressure Switch		
High Gas Pressure Switch		
Proof of Closure (POC)		
Blocked Flue Switch		

DEVICE	SETTING	OPERATIONAL
Air Filter Switch		
High Temperature Limit		
Temperature Controller		
Fuel Train Leak Test		
Blower Leak Test		

MODULE 1

COMBUSTION SETTINGS: Fuel Type is *Natural Gas*

FIRING POSITION:	P0 LIGHT	P1	P2	P3	P4	P5	P6	P7	P8	P9 100%
Fuel Position AZL										
Air Position AZL										
VFD Position AZL										
VFD Hertz										
Supply Gas Pressure (InWC)										
Manifold Gas Pressure (InWC)										
MV Downstream Gas (InWC)										
Fan Discharge Pressure (InWC)										
Wet (Stack Analyzer) O2%										
Dry (Burner Sensor) O2%										
CO2 %										
CO ppm										
NOx @ 3%										
Excess Air %										
Room Ambient Temp. °F										
Combustion Air Temp. °F										
Stack Temperature °F										
Stack Draft (InWC)*										
Inlet Water Temp. °F										
Outlet Water Temp. °F										
Main Flame Signal										
Pilot Flame Signal**										

* Use only a Slack Tube® Manometer or equivalent. The use of a digital manometer is not recommended.

** Where applicable.



MODULE 2

COMBUSTION SETTINGS: *Fuel Type is Natural Gas*

FIRING POSITION:	P0 LIGHT	P1	P2	P3	P4	P5	P6	P7	P8	P9 100%
Fuel Position AZL										
Air Position AZL										
VFD Position AZL										
VFD Hertz										
Supply Gas Pressure (InWC)				▣	▣	▣	▣	▣	▣	
Manifold Gas Pressure (InWC)										
MV Downstream Gas (InWC)				▣	▣	▣	▣	▣	▣	
Fan Discharge Pressure (InWC)										
Wet (Stack Analyzer) O2%										
Dry (Burner Sensor) O2%										
CO2 %										
CO ppm										
NOx @ 3%										
Excess Air %										
Room Ambient Temp. °F		▣	▣	▣	▣	▣	▣	▣	▣	
Combustion Air Temp. °F		▣	▣	▣	▣	▣	▣	▣	▣	
Stack Temperature °F										
Stack Draft (InWC)*										
Inlet Water Temp. °F										
Outlet Water Temp. °F										
Main Flame Signal										
Pilot Flame Signal**		▣	▣	▣	▣	▣	▣	▣	▣	▣

* Use only a Slack Tube® Manometer or equivalent. The use of a digital manometer is not recommended.

** Where applicable.

OPERATING HISTORY (SIEMENS LMV3):

P-161 Total Faults	
P-162 Operating Hours	
P-166 Number of Startups	
Controller Hours	

When complete, please keep this form with the boiler and store a record copy in a safe location. Accurate and complete combustion and maintenance records detailing compliance with the Installation, Operation, and Maintenance Manual must be produced for warranty consideration. Please use photocopies or consult your local Fulton Representative for additional copies of this form.

PAGE INTENTIONALLY LEFT BLANK



ANNUAL MAINTENANCE CHECKLIST

NOTE:

TO BE COMPLETED BY A FACTORY AUTHORIZED TECHNICIAN HOLDING A VALID EDR CERTIFICATE OF REGISTRATION.

DATE	
TECHNICIAN	
TECH. COMPANY	

TECH CERTIFICATE #	
BOILER MODEL	
NATIONAL BOARD #'S	

ANNUAL MAINTENANCE:

Burner head removed and visually inspected	<input type="checkbox"/>	COMPLETE
Burner head cleaned (30-72.5 psi air only)	<input type="checkbox"/>	COMPLETE
Burner head reinstalled with new gaskets	<input type="checkbox"/>	COMPLETE
Burner flange hardware torqued to spec (see Section 4 of IOM)	<input type="checkbox"/>	COMPLETE
Low water probe(s) removed, cleaned, and reinstalled	<input type="checkbox"/>	COMPLETE
Combustion air inlet filter replaced with new	<input type="checkbox"/>	COMPLETE
Direct spark ignition replaced with new (where applicable)	<input type="checkbox"/>	COMPLETE
Oxygen sensor replaced with new, Reset O2, and Set Initial O2 performed	<input type="checkbox"/>	COMPLETE
PURE Control software/firmware update installed (where directed)	<input type="checkbox"/>	COMPLETE
Special gas vent system and condensate drains inspected	<input type="checkbox"/>	COMPLETE
Combustion air intake inspected	<input type="checkbox"/>	COMPLETE
Safety relief valve tested, replace if it does not fully reseal	<input type="checkbox"/>	COMPLETE
Flexible premix couplings inspected, replace immediately if worn	<input type="checkbox"/>	COMPLETE
Open factory Service Bulletin(s) addressed (where applicable)	<input type="checkbox"/>	COMPLETE
Safety checks table completed		(fill in tables below)
Combustion verification completed, adjust as necessary		(fill in tables on reserve side)

WATER CHEMISTRY: Verify water chemistry is within specific limits, correct where required.

pH (8.5-10.5)	_____
Oxygen (<250 ppb)	_____ ppb
Iron/Copper (<5 ppb)	_____ ppm
Chloride (<200 ppb)	_____ ppm
Hardness (<60 ppm)	_____ ppm
Glycol % (Maximum 50%, glycol systems require 30 psi minimum)	_____ %

MODULE 1

SAFETY CHECKS: Check all safeties below for proper operation and document the final settings.

DEVICE	SETTING	OPERATIONAL
Low Water Safety		
Air Switch		
Low Gas Pressure Switch		
High Gas Pressure Switch		
Proof of Closure (POC)		
Blocked Flue Switch		

DEVICE	SETTING	OPERATIONAL
Air Filter Switch		
High Temperature Limit		
Temperature Controller		
Fuel Train Leak Test		
Blower Leak Test		

MODULE 2

SAFETY CHECKS: Check all safeties below for proper operation and document the final settings.

DEVICE	SETTING	OPERATIONAL
Low Water Safety		
Air Switch		
Low Gas Pressure Switch		
High Gas Pressure Switch		
Proof of Closure (POC)		
Blocked Flue Switch		

DEVICE	SETTING	OPERATIONAL
Air Filter Switch		
High Temperature Limit		
Temperature Controller		
Fuel Train Leak Test		
Blower Leak Test		

MODULE 1

COMBUSTION SETTINGS: Fuel Type is *Natural Gas*

FIRING POSITION:	P0 LIGHT	P1	P2	P3	P4	P5	P6	P7	P8	P9 100%
Fuel Position AZL										
Air Position AZL										
VFD Position AZL										
VFD Hertz										
Supply Gas Pressure (InWC)										
Manifold Gas Pressure (InWC)										
MV Downstream Gas (InWC)										
Fan Discharge Pressure (InWC)										
Wet (Stack Analyzer) O2%										
Dry (Burner Sensor) O2%										
CO2 %										
CO ppm										
NOx @ 3%										
Excess Air %										
Room Ambient Temp. °F										
Combustion Air Temp. °F										
Stack Temperature °F										
Stack Draft (InWC)*										
Inlet Water Temp. °F										
Outlet Water Temp. °F										
Main Flame Signal										
Pilot Flame Signal**										

* Use only a Slack Tube® Manometer or equivalent. The use of a digital manometer is not recommended.

** Where applicable.



MODULE 2

COMBUSTION SETTINGS: *Fuel Type is Natural Gas*

FIRING POSITION:	P0 LIGHT	P1	P2	P3	P4	P5	P6	P7	P8	P9 100%
Fuel Position AZL										
Air Position AZL										
VFD Position AZL										
VFD Hertz										
Supply Gas Pressure (InWC)				▣	▣	▣	▣	▣	▣	
Manifold Gas Pressure (InWC)										
MV Downstream Gas (InWC)				▣	▣	▣	▣	▣	▣	
Fan Discharge Pressure (InWC)										
Wet (Stack Analyzer) O2%										
Dry (Burner Sensor) O2%										
CO2 %										
CO ppm										
NOx @ 3%										
Excess Air %										
Room Ambient Temp. °F		▣	▣	▣	▣	▣	▣	▣	▣	
Combustion Air Temp. °F		▣	▣	▣	▣	▣	▣	▣	▣	
Stack Temperature °F										
Stack Draft (InWC)*										
Inlet Water Temp. °F										
Outlet Water Temp. °F										
Main Flame Signal										
Pilot Flame Signal**		▣	▣	▣	▣	▣	▣	▣	▣	▣

* Use only a Slack Tube® Manometer or equivalent. The use of a digital manometer is not recommended.

** Where applicable.

OPERATING HISTORY (SIEMENS LMV3):

P-161 Total Faults	
P-162 Operating Hours	
P-166 Number of Startups	
Controller Hours	

When complete, please keep this form with the boiler and store a record copy in a safe location. Accurate and complete combustion and maintenance records detailing compliance with the Installation, Operation, and Maintenance Manual must be produced for warranty consideration. Please use photocopies or consult your local Fulton Representative for additional copies of this form.

PAGE INTENTIONALLY LEFT BLANK



ANNUAL MAINTENANCE CHECKLIST

NOTE:

TO BE COMPLETED BY A FACTORY AUTHORIZED TECHNICIAN HOLDING A VALID EDR CERTIFICATE OF REGISTRATION.

DATE	
TECHNICIAN	
TECH. COMPANY	

TECH CERTIFICATE #	
BOILER MODEL	
NATIONAL BOARD #'S	

ANNUAL MAINTENANCE:

Burner head removed and visually inspected	<input type="checkbox"/>	COMPLETE
Burner head cleaned (30-72.5 psi air only)	<input type="checkbox"/>	COMPLETE
Burner head reinstalled with new gaskets	<input type="checkbox"/>	COMPLETE
Burner flange hardware torqued to spec (see Section 4 of IOM)	<input type="checkbox"/>	COMPLETE
Low water probe(s) removed, cleaned, and reinstalled	<input type="checkbox"/>	COMPLETE
Combustion air inlet filter replaced with new	<input type="checkbox"/>	COMPLETE
Direct spark ignition replaced with new (where applicable)	<input type="checkbox"/>	COMPLETE
Oxygen sensor replaced with new, Reset O2, and Set Initial O2 performed	<input type="checkbox"/>	COMPLETE
PURE Control software/firmware update installed (where directed)	<input type="checkbox"/>	COMPLETE
Special gas vent system and condensate drains inspected	<input type="checkbox"/>	COMPLETE
Combustion air intake inspected	<input type="checkbox"/>	COMPLETE
Safety relief valve tested, replace if it does not fully reseal	<input type="checkbox"/>	COMPLETE
Flexible premix couplings inspected, replace immediately if worn	<input type="checkbox"/>	COMPLETE
Open factory Service Bulletin(s) addressed (where applicable)	<input type="checkbox"/>	COMPLETE
Safety checks table completed		(fill in tables below)
Combustion verification completed, adjust as necessary		(fill in tables on reserve side)

WATER CHEMISTRY: Verify water chemistry is within specific limits, correct where required.

pH (8.5-10.5)	_____	
Oxygen (<250 ppb)	_____	ppb
Iron/Copper (<5 ppb)	_____	ppm
Chloride (<200 ppb)	_____	ppm
Hardness (<60 ppm)	_____	ppm
Glycol % (Maximum 50%, glycol systems require 30 psi minimum)	_____	%

MODULE 1

SAFETY CHECKS: Check all safeties below for proper operation and document the final settings.

DEVICE	SETTING	OPERATIONAL
Low Water Safety		
Air Switch		
Low Gas Pressure Switch		
High Gas Pressure Switch		
Proof of Closure (POC)		
Blocked Flue Switch		

DEVICE	SETTING	OPERATIONAL
Air Filter Switch		
High Temperature Limit		
Temperature Controller		
Fuel Train Leak Test		
Blower Leak Test		

MODULE 2

SAFETY CHECKS: Check all safeties below for proper operation and document the final settings.

DEVICE	SETTING	OPERATIONAL
Low Water Safety		
Air Switch		
Low Gas Pressure Switch		
High Gas Pressure Switch		
Proof of Closure (POC)		
Blocked Flue Switch		

DEVICE	SETTING	OPERATIONAL
Air Filter Switch		
High Temperature Limit		
Temperature Controller		
Fuel Train Leak Test		
Blower Leak Test		

MODULE 1

COMBUSTION SETTINGS: Fuel Type is *Natural Gas*

FIRING POSITION:	P0 LIGHT	P1	P2	P3	P4	P5	P6	P7	P8	P9 100%
Fuel Position AZL										
Air Position AZL										
VFD Position AZL										
VFD Hertz										
Supply Gas Pressure (InWC)										
Manifold Gas Pressure (InWC)										
MV Downstream Gas (InWC)										
Fan Discharge Pressure (InWC)										
Wet (Stack Analyzer) O2%										
Dry (Burner Sensor) O2%										
CO2 %										
CO ppm										
NOx @ 3%										
Excess Air %										
Room Ambient Temp. °F										
Combustion Air Temp. °F										
Stack Temperature °F										
Stack Draft (InWC)*										
Inlet Water Temp. °F										
Outlet Water Temp. °F										
Main Flame Signal										
Pilot Flame Signal**										

* Use only a Slack Tube® Manometer or equivalent. The use of a digital manometer is not recommended.

** Where applicable.



MODULE 2

COMBUSTION SETTINGS: *Fuel Type is Natural Gas*

FIRING POSITION:	P0 LIGHT	P1	P2	P3	P4	P5	P6	P7	P8	P9 100%
Fuel Position AZL										
Air Position AZL										
VFD Position AZL										
VFD Hertz										
Supply Gas Pressure (InWC)				▣	▣	▣	▣	▣	▣	▣
Manifold Gas Pressure (InWC)										
MV Downstream Gas (InWC)				▣	▣	▣	▣	▣	▣	▣
Fan Discharge Pressure (InWC)										
Wet (Stack Analyzer) O2%										
Dry (Burner Sensor) O2%										
CO2 %										
CO ppm										
NOx @ 3%										
Excess Air %										
Room Ambient Temp. °F		▣	▣	▣	▣	▣	▣	▣	▣	▣
Combustion Air Temp. °F		▣	▣	▣	▣	▣	▣	▣	▣	▣
Stack Temperature °F										
Stack Draft (InWC)*										
Inlet Water Temp. °F										
Outlet Water Temp. °F										
Main Flame Signal										
Pilot Flame Signal**		▣	▣	▣	▣	▣	▣	▣	▣	▣

* Use only a Slack Tube® Manometer or equivalent. The use of a digital manometer is not recommended.

** Where applicable.

OPERATING HISTORY (SIEMENS LMV3):

P-161 Total Faults	
P-162 Operating Hours	
P-166 Number of Startups	
Controller Hours	

When complete, please keep this form with the boiler and store a record copy in a safe location. Accurate and complete combustion and maintenance records detailing compliance with the Installation, Operation, and Maintenance Manual must be produced for warranty consideration. Please use photocopies or consult your local Fulton Representative for additional copies of this form.

PAGE INTENTIONALLY LEFT BLANK



ANNUAL MAINTENANCE CHECKLIST

NOTE:

TO BE COMPLETED BY A FACTORY AUTHORIZED TECHNICIAN HOLDING A VALID EDR CERTIFICATE OF REGISTRATION.

DATE	TECH CERTIFICATE #
TECHNICIAN	BOILER MODEL
TECH. COMPANY	NATIONAL BOARD #'S

ANNUAL MAINTENANCE:

Burner head removed and visually inspected	<input type="checkbox"/> COMPLETE
Burner head cleaned (30-72.5 psi air only)	<input type="checkbox"/> COMPLETE
Burner head reinstalled with new gaskets	<input type="checkbox"/> COMPLETE
Burner flange hardware torqued to spec (see Section 4 of IOM)	<input type="checkbox"/> COMPLETE
Low water probe(s) removed, cleaned, and reinstalled	<input type="checkbox"/> COMPLETE
Combustion air inlet filter replaced with new	<input type="checkbox"/> COMPLETE
Direct spark ignition replaced with new (where applicable)	<input type="checkbox"/> COMPLETE
Oxygen sensor replaced with new, Reset O2, and Set Initial O2 performed	<input type="checkbox"/> COMPLETE
PURE Control software/firmware update installed (where directed)	<input type="checkbox"/> COMPLETE
Special gas vent system and condensate drains inspected	<input type="checkbox"/> COMPLETE
Combustion air intake inspected	<input type="checkbox"/> COMPLETE
Safety relief valve tested, replace if it does not fully reseal	<input type="checkbox"/> COMPLETE
Flexible premix couplings inspected, replace immediately if worn	<input type="checkbox"/> COMPLETE
Open factory Service Bulletin(s) addressed (where applicable)	<input type="checkbox"/> COMPLETE
Safety checks table completed	(fill in tables below)
Combustion verification completed, adjust as necessary	(fill in tables on reserve side)

WATER CHEMISTRY: Verify water chemistry is within specific limits, correct where required.

pH (8.5-10.5)	_____
Oxygen (<250 ppb)	_____ ppb
Iron/Copper (<5 ppb)	_____ ppm
Chloride (<200 ppb)	_____ ppm
Hardness (<60 ppm)	_____ ppm
Glycol % (Maximum 50%, glycol systems require 30 psi minimum)	_____ %

MODULE 1

SAFETY CHECKS: Check all safeties below for proper operation and document the final settings.

DEVICE	SETTING	OPERATIONAL	DEVICE	SETTING	OPERATIONAL
Low Water Safety			Air Filter Switch		
Air Switch			High Temperature Limit		
Low Gas Pressure Switch			Temperature Controller		
High Gas Pressure Switch			Fuel Train Leak Test		
Proof of Closure (POC)			Blower Leak Test		
Blocked Flue Switch					

MODULE 2

SAFETY CHECKS: Check all safeties below for proper operation and document the final settings.

DEVICE	SETTING	OPERATIONAL
Low Water Safety		
Air Switch		
Low Gas Pressure Switch		
High Gas Pressure Switch		
Proof of Closure (POC)		
Blocked Flue Switch		

DEVICE	SETTING	OPERATIONAL
Air Filter Switch		
High Temperature Limit		
Temperature Controller		
Fuel Train Leak Test		
Blower Leak Test		

MODULE 1

COMBUSTION SETTINGS: Fuel Type is *Natural Gas*

FIRING POSITION:	P0 LIGHT	P1	P2	P3	P4	P5	P6	P7	P8	P9 100%
Fuel Position AZL										
Air Position AZL										
VFD Position AZL										
VFD Hertz										
Supply Gas Pressure (InWC)										
Manifold Gas Pressure (InWC)										
MV Downstream Gas (InWC)										
Fan Discharge Pressure (InWC)										
Wet (Stack Analyzer) O2%										
Dry (Burner Sensor) O2%										
CO2 %										
CO ppm										
NOx @ 3%										
Excess Air %										
Room Ambient Temp. °F										
Combustion Air Temp. °F										
Stack Temperature °F										
Stack Draft (InWC)*										
Inlet Water Temp. °F										
Outlet Water Temp. °F										
Main Flame Signal										
Pilot Flame Signal**										

* Use only a Slack Tube® Manometer or equivalent. The use of a digital manometer is not recommended.

** Where applicable.



MODULE 2

COMBUSTION SETTINGS: *Fuel Type is Natural Gas*

FIRING POSITION:	P0 LIGHT	P1	P2	P3	P4	P5	P6	P7	P8	P9 100%
Fuel Position AZL										
Air Position AZL										
VFD Position AZL										
VFD Hertz										
Supply Gas Pressure (InWC)				▣	▣	▣	▣	▣	▣	▣
Manifold Gas Pressure (InWC)										
MV Downstream Gas (InWC)				▣	▣	▣	▣	▣	▣	▣
Fan Discharge Pressure (InWC)										
Wet (Stack Analyzer) O2%										
Dry (Burner Sensor) O2%										
CO2 %										
CO ppm										
NOx @ 3%										
Excess Air %										
Room Ambient Temp. °F		▣	▣	▣	▣	▣	▣	▣	▣	▣
Combustion Air Temp. °F		▣	▣	▣	▣	▣	▣	▣	▣	▣
Stack Temperature °F										
Stack Draft (InWC)*										
Inlet Water Temp. °F										
Outlet Water Temp. °F										
Main Flame Signal										
Pilot Flame Signal**		▣	▣	▣	▣	▣	▣	▣	▣	▣

** Use only a Slack Tube® Manometer or equivalent. The use of a digital manometer is not recommended.*

*** Where applicable.*

OPERATING HISTORY (SIEMENS LMV3):

P-161 Total Faults	
P-162 Operating Hours	
P-166 Number of Startups	
Controller Hours	

When complete, please keep this form with the boiler and store a record copy in a safe location. Accurate and complete combustion and maintenance records detailing compliance with the Installation, Operation, and Maintenance Manual must be produced for warranty consideration. Please use photocopies or consult your local Fulton Representative for additional copies of this form.

PAGE INTENTIONALLY LEFT BLANK



ANNUAL MAINTENANCE CHECKLIST

NOTE:

TO BE COMPLETED BY A FACTORY AUTHORIZED TECHNICIAN HOLDING A VALID EDR CERTIFICATE OF REGISTRATION.

DATE	
TECHNICIAN	
TECH. COMPANY	

TECH CERTIFICATE #	
BOILER MODEL	
NATIONAL BOARD #'S	

ANNUAL MAINTENANCE:

Burner head removed and visually inspected	<input type="checkbox"/>	COMPLETE
Burner head cleaned (30-72.5 psi air only)	<input type="checkbox"/>	COMPLETE
Burner head reinstalled with new gaskets	<input type="checkbox"/>	COMPLETE
Burner flange hardware torqued to spec (see Section 4 of IOM)	<input type="checkbox"/>	COMPLETE
Low water probe(s) removed, cleaned, and reinstalled	<input type="checkbox"/>	COMPLETE
Combustion air inlet filter replaced with new	<input type="checkbox"/>	COMPLETE
Direct spark ignition replaced with new (where applicable)	<input type="checkbox"/>	COMPLETE
Oxygen sensor replaced with new, Reset O2, and Set Initial O2 performed	<input type="checkbox"/>	COMPLETE
PURE Control software/firmware update installed (where directed)	<input type="checkbox"/>	COMPLETE
Special gas vent system and condensate drains inspected	<input type="checkbox"/>	COMPLETE
Combustion air intake inspected	<input type="checkbox"/>	COMPLETE
Safety relief valve tested, replace if it does not fully reseal	<input type="checkbox"/>	COMPLETE
Flexible premix couplings inspected, replace immediately if worn	<input type="checkbox"/>	COMPLETE
Open factory Service Bulletin(s) addressed (where applicable)	<input type="checkbox"/>	COMPLETE
Safety checks table completed		(fill in tables below)
Combustion verification completed, adjust as necessary		(fill in tables on reserve side)

WATER CHEMISTRY: Verify water chemistry is within specific limits, correct where required.

pH (8.5-10.5)	_____	
Oxygen (<250 ppb)	_____	ppb
Iron/Copper (<5 ppb)	_____	ppm
Chloride (<200 ppb)	_____	ppm
Hardness (<60 ppm)	_____	ppm
Glycol % (Maximum 50%, glycol systems require 30 psi minimum)	_____	%

MODULE 1

SAFETY CHECKS: Check all safeties below for proper operation and document the final settings.

DEVICE	SETTING	OPERATIONAL
Low Water Safety		
Air Switch		
Low Gas Pressure Switch		
High Gas Pressure Switch		
Proof of Closure (POC)		
Blocked Flue Switch		

DEVICE	SETTING	OPERATIONAL
Air Filter Switch		
High Temperature Limit		
Temperature Controller		
Fuel Train Leak Test		
Blower Leak Test		

MODULE 2

SAFETY CHECKS: Check all safeties below for proper operation and document the final settings.

DEVICE	SETTING	OPERATIONAL
Low Water Safety		
Air Switch		
Low Gas Pressure Switch		
High Gas Pressure Switch		
Proof of Closure (POC)		
Blocked Flue Switch		

DEVICE	SETTING	OPERATIONAL
Air Filter Switch		
High Temperature Limit		
Temperature Controller		
Fuel Train Leak Test		
Blower Leak Test		

MODULE 1

COMBUSTION SETTINGS: Fuel Type is *Natural Gas*

FIRING POSITION:	P0 LIGHT	P1	P2	P3	P4	P5	P6	P7	P8	P9 100%
Fuel Position AZL										
Air Position AZL										
VFD Position AZL										
VFD Hertz										
Supply Gas Pressure (InWC)										
Manifold Gas Pressure (InWC)										
MV Downstream Gas (InWC)										
Fan Discharge Pressure (InWC)										
Wet (Stack Analyzer) O2%										
Dry (Burner Sensor) O2%										
CO2 %										
CO ppm										
NOx @ 3%										
Excess Air %										
Room Ambient Temp. °F										
Combustion Air Temp. °F										
Stack Temperature °F										
Stack Draft (InWC)*										
Inlet Water Temp. °F										
Outlet Water Temp. °F										
Main Flame Signal										
Pilot Flame Signal**										

* Use only a Slack Tube® Manometer or equivalent. The use of a digital manometer is not recommended.

** Where applicable.



MODULE 2

COMBUSTION SETTINGS: *Fuel Type is Natural Gas*

FIRING POSITION:	P0 LIGHT	P1	P2	P3	P4	P5	P6	P7	P8	P9 100%
Fuel Position AZL										
Air Position AZL										
VFD Position AZL										
VFD Hertz										
Supply Gas Pressure (InWC)				▣	▣	▣	▣	▣	▣	▣
Manifold Gas Pressure (InWC)										
MV Downstream Gas (InWC)				▣	▣	▣	▣	▣	▣	▣
Fan Discharge Pressure (InWC)										
Wet (Stack Analyzer) O2%										
Dry (Burner Sensor) O2%										
CO2 %										
CO ppm										
NOx @ 3%										
Excess Air %										
Room Ambient Temp. °F		▣	▣	▣	▣	▣	▣	▣	▣	▣
Combustion Air Temp. °F		▣	▣	▣	▣	▣	▣	▣	▣	▣
Stack Temperature °F										
Stack Draft (InWC)*										
Inlet Water Temp. °F										
Outlet Water Temp. °F										
Main Flame Signal										
Pilot Flame Signal**		▣	▣	▣	▣	▣	▣	▣	▣	▣

** Use only a Slack Tube® Manometer or equivalent. The use of a digital manometer is not recommended.*

*** Where applicable.*

OPERATING HISTORY (SIEMENS LMV3):

P-161 Total Faults	
P-162 Operating Hours	
P-166 Number of Startups	
Controller Hours	

When complete, please keep this form with the boiler and store a record copy in a safe location. Accurate and complete combustion and maintenance records detailing compliance with the Installation, Operation, and Maintenance Manual must be produced for warranty consideration. Please use photocopies or consult your local Fulton Representative for additional copies of this form.

**No part of this Installation, Operation, and Maintenance manual
may be reproduced in any form or by any means without
permission in writing from Fulton Group N.A., Inc.**

Fulton Steam Solutions, Inc., Fulton Heating Solutions, Inc. & Fulton Thermal Corporation are part of Fulton Group N.A., Inc., a global manufacturer of steam, hot water and thermal fluid heat transfer systems.

© Fulton Group N.A., Inc. 2022



Fulton Heating Solutions

6288 Running Ridge Road, Syracuse, NY 13212

Call: (315) 298-5121 • Fax: (315) 298-6390

The heat transfer innovators



www.fulton.com

EDRP-8-12MM-IOM-220517