



Serial Number: \_\_\_\_\_  
Model Number: \_\_\_\_\_  
Fulton Order Number: \_\_\_\_\_  
Sold To: \_\_\_\_\_  
Job Name: \_\_\_\_\_  
Date: \_\_\_\_\_

**Instruction, Operation,  
and Maintenance  
Manual**

**Fulton Gas Fired Steam  
Boilers**

I HP to 60 HP

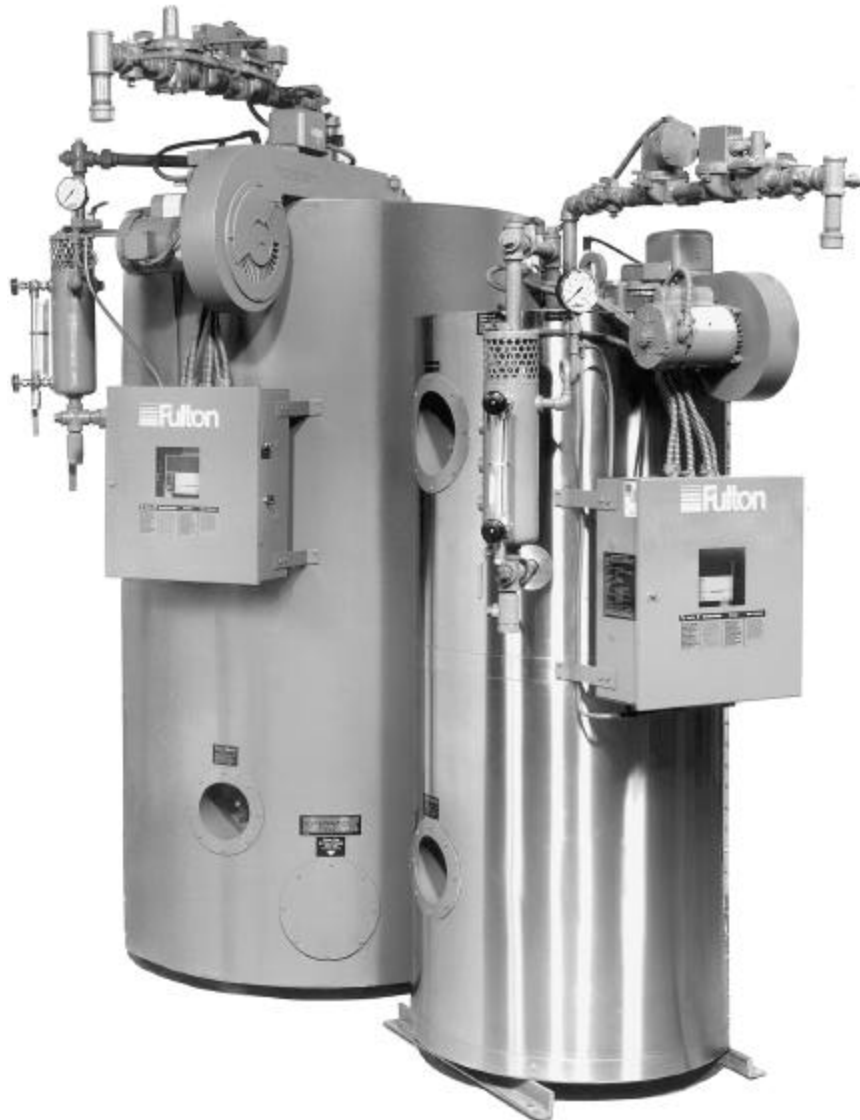



# Product Bulletin

**Date:** January 22, 2010

**Subject:** Water Chemistry Requirements for Fulton Steam Products

**Products:** ICS/ICX, FB-A, FB-F, FB-S, VMP, PVLP, PHP, Electric Steam Boilers and Unfired Steam Generators

Please note that the water chemistry is different for carbon steel vs. stainless steel pressure vessels and vertical vs. horizontal orientation.

Effective immediately, please use the limits below. Should you have any questions, please do not hesitate to contact Fulton at 315-298-5121.

### Water Chemistry Requirements for Fulton Steam Products (to 300 psig MAWP)

Parameter	Carbon Steel			Stainless Steel		
	Feedwater	Vertical Boiler/Steam Pac Water	Horizontal Boiler/Steam Pac Water	Feedwater	Vertical Boiler/Steam Pac Water	Horizontal Boiler/Steam Pac Water
<i>pH</i>	7.5-9.5	8.5-10.5	8.5-10.5	6.0-9.5	8.5-10.5	8.5-10.5
<i>Feedwater Temperature</i>	140F*	---	---	140F*	---	---
<i>Hardness as CaCO<sub>3</sub></i>	<2ppm	<10 ppm	<15 ppm	<2 ppm	<10 ppm	<15 ppm
<i>Chlorides</i>	---	---	---	---	50 ppm	50 ppm
<i>Total Alkalinity</i>	---	<300 ppm	<500 ppm	---	<300 ppm	<500 ppm
<i>Total Dissolved Solids</i>	---	<2000 ppm	<3000 ppm	---	<2000 ppm	<3000 ppm
<i>Suspended Solids</i>	No visual turbidity**	No visual turbidity**	No visual turbidity**	No visual turbidity**	No visual turbidity**	No visual turbidity**
<i>Total Organic Carbon</i>	No sheen No foam+	No sheen No foam+	No sheen No foam+	No sheen No foam+	No sheen No foam+	No sheen No foam+
<i>Iron</i>	Colorless liquid++	Colorless liquid++	Colorless liquid++	Colorless liquid++	Colorless liquid++	Colorless liquid++
<i>Dissolved Oxygen</i>	<1ppm*	ND	ND	<5ppm	ND	ND
<i>Visual Oil</i>	ND	ND	ND	ND	ND	ND
<i>Conductivity (uS/cm)</i>	---	<2985	<4477	---	<2985	<4477

**NOTES:**

\*This is a minimum temperature. Feedwater temperatures below 200F will require an oxygen scavenger.

\*\* Suspended solids: Take a water sample. After the sample sits for 10 minutes, no solids should be visible.

+ Total Organic Carbon: Take a water sample. Shake vigorously for 30 seconds. No sheen or foam should be visible.

++ Iron: Take a water sample. Hold the sample against a white background. The water should have no visible yellow, red or orange tinge.

ND: None Detected.



# Introduction

---

This manual is provided as a guide to the correct operation and maintenance of your Fulton Gas Fired Steam Boiler, and should be permanently available to the staff responsible for the operation of the gas fired boiler.

These instructions must not be considered as a complete code of practice, nor should they replace existing codes or standards which may be applicable.

The requirements and instructions contained in this section generally relate to the standard Fulton Gas Fired Steam Boiler. When installing a packaged unit, this entire section should be read to ensure that the installation work is carried out correctly.

Prior to shipment the following tests are made to assure the customer the highest standards of manufacturing:

- a) Material inspections.
- b) Manufacturing process inspections.
- c) ASME welding inspections.
- d) ASME hydrostatic test inspection.
- e) Electrical components inspection.
- f) Operating test.
- g) Final Engineering Inspection
- h) Crating inspection.

## NOTE

**The installation of the Fulton Gas Fired Steam Boiler should be carried out by competent personnel in accordance with the standards of the National Fire Protection Association, National or Canadian Electrical Code. All state and juris-**

**dictional codes beyond the scope of the applicable ASME Boiler and Pressure Vessel Codes, for its corresponding classification, should be followed in all cases. Jurisdictional authorities must be consulted prior to installation.**

All units are crated for fork lift transport. Once uncrated, all units can be transported with a forklift. Under no circumstances should weight be allowed to bear on the jacket, control panel, or fan housing of any Fulton Boiler.

Rigging your boiler into position should be handled by a competent rigger experienced in handling heavy equipment.

The customer should examine the boiler for any damage, especially the refractories.



# Contents

---

## Section

<b>1</b>	<b>Safety Warnings &amp; Precautions</b>
<b>LE</b>	<b>For Boilers with Low Emissions Burner Only</b>
<b>2</b>	<b>Description/Instructions</b> Specifications & Dimensions 4-60 HP Locating the Boiler The Gas Supply Boiler, Condensate Tank, and Blow off Separator Piping Boiler Installation The Steam Supply The Steam Safety Valve The Steam Pressure Gauge Assembly The Blow Off Valve The Feed Water Piping The Water Column Water Gauge & Gauge Glass Installation Instructions Water Supply Recommended Water Treatment Glossary of Water Supply Corrosives & Inhibitors Electrical Requirements Fresh Air Supply for Boiler Conventional Venting Combustion Air Intake (UL and MEA Approved) Corrosion of Flue Pipe Installation Checkpoints Cleaning the Pressure Vessel
<b>3</b>	<b>Operation</b> Starting the Gas Fired Boiler Gas Burner Set Up Gas Burner Set Up For Boilers Equipped With Modulation Gas Burner Set Up For Boilers Equipped With High-Low-Off Primary Air Adjustment Secondary Air Adjustment Boiler Controls
<b>4</b>	<b>Maintenance</b> Cut Away Gas Boiler Procedure for Cleaning Water Probes Flame Rod Adjustment Flame Scanner Adjustments Stainless Steel Combustion Ring Furnace Refractory Replacement Recommended Daily Maintenance Recommended Weekly Maintenance Recommended Monthly Maintenance Recommended Semi Annual Maintenance Procedure to Replace Hand Hole Gaskets Recommended Annual Maintenance Troubleshooting
<b>5</b>	<b>Parts</b> Spare Parts Ordering Instructions
<b>6</b>	<b>Warranty</b>
<b>7</b>	<b>Component Data Sheets</b>



**1**



# Safety Warnings/Precautions

## Safety Warnings Cautions & Notes

The following **WARNINGS**, **CAUTIONS**, and **NOTES** appear in various chapters of this manual. They are repeated on these safety summary pages as an example and for emphasis.

**WARNINGS** must be observed to prevent serious injury, or death to personnel.

**CAUTIONS** must be observed to prevent damage or destruction of equipment or loss of operating effectiveness.

**NOTES** must be observed for essential and effective operating procedures, conditions, and as a statement to be highlighted.

It is the responsibility and duty of all personnel involved in the operation and maintenance of this equipment to fully understand the **WARNINGS**, **CAUTIONS**, and **NOTES** by which hazards are to be reduced or eliminated. Personnel must become thoroughly familiar with all aspects of safety and equipment prior to operation or maintenance of the equipment.

### CAUTION

Some soaps used for leak testing are corrosive to certain types of metals. Rinse all piping thoroughly with clean water after leak check has been completed.

### NOTE

Where a condensate return tank is to be fitted, this should:

1. Be vented and
2. Have a capacity sufficient to satisfy boiler consumption as well as maintain proper return tank temperature.
3. Vent pipe should not be down-sized (This may cause pressure build up in the condensate tank.)
4. Return pipes must not be insulated. This can cause overheating the return system, causing a vapor lock in the pump.
5. See Return System Instruction Manual for detailed instructions.

### NOTE

Care should be taken to ensure that the blow off receptacle used meets the regulations covering such vessels. If in doubt consult a Fulton Representative for advice.

### NOTE

Only properly trained personnel should install and maintain water gauge glass and connections. Wear safety glasses during installation. Before installing, make sure all parts are free of chips and debris.

### NOTE

Keep gauge glass in original packaging until ready to install.

### WARNING

Improper installation or maintenance of gauge glass and connections can cause immediate or delayed breakage resulting in bodily injury and/or property damage.

### NOTE

After installation is complete and prior to operation the pressure vessel should be cleaned.

### CAUTION

Do not store halogenated hydrocarbons near or in the boiler room.

### NOTE

a) The fused disconnect switch that controls the feed water pump should be kept in the "on" position at all times during the boiler operation as well as during the non-operating period of the boiler.

b) This switch should be turned "off" only when repairs or adjustments should be made.

### NOTE

The pump will continue to operate until the water reaches the correct level in the boiler. This level is approximately the center of the water gauge glass.

### WARNING

Prior to the commencement of any work requiring the removal of cover plates and the opening of the control panel box, the electrical supply to the boiler must be disconnected.

### CAUTION

Do not tamper with the safety features of the low water safety cut off.

### WARNING

When stopping the boiler for any extensive repairs, shut off main disconnect switches on both the boiler side as well as the feed water side.

### NOTE

To ensure that your Fulton Steam Boiler is kept operating safely and efficiently, follow the maintenance procedures set forth in Section 4 of this manual.

### NOTE

To ensure the continued safety and efficiency of the boiler, the schedule of maintenance outlined in this section should be adhered to.

### WARNING

Prior to the commencement of any work requiring the removal of cover plates and the opening of the control panel box, the electrical supply to the boiler must be disconnected.

### NOTE

The scanner is located on the outside edge of the burner top plate for 20-60 HP.

### NOTE

If only the top refractory is to be changed, the bottom refractory need not be broken.

### NOTE

If the boiler is being operated automatically on a time clock, the blow off operation may be done once during the working day and once at the end of the day when at 10 PSIG or less.

### NOTE

Fulton recommends that the feedwater treatment should be added between the pump and the boiler.

### WARNING

Make sure main power switch is off before starting work.

### CAUTION

Do not clean the gauge or glass while pressurized or in operation.

### NOTE

After a new Fulton Boiler has been in operation for several months, pieces of burned metal will be found in the space at the bottom of the boiler. These pieces of metal are the remains of a light gauge metal form which was used during manufacture for forming the boiler insulation. This is a normal condition and does not affect the efficiency or the life of the boiler in any way.



**LE**





**Product Data Submittal**  
**Fulton Models: ICS/FB-A and ICX/FB-F**

**Fulton Gas & Oil Fired**  
**Vertical Tubeless**  
**Steam Boilers**

**(Low Emissions Burner)**

**Dimensions**

Standard Models ICS/FB-A Models ICX/FB-F		9.5	10	15	20	25	30
		9.5	10	15	20	25	30
Unit Size:	BHP	9.5	10	15	20	25	30
A. Boiler Height	IN	67.5	63.5	69	72.5	74.5	82
	MM	1715	1613	1753	1842	1892	2083
B. Boiler Height With Trim* & Fuel Train Assembly	IN	85	80.5	93	97	97	106.5
	MM	2159	2045	2362	2364	2364	2705
C. Overall Depth Stack to Burner Fan Housing	IN	44	48	50	61	59	65.5
	MM	1118	1219	1270	1549	1499	1664
D. Boiler Diameter	IN	26	28	30	39	39	46
	MM	660	710	760	990	990	1170
E. Overall Width with Water Column	IN	33	33.5	35.5	43	43	49
	MM	838	851	902	1091	1091	1244
F. Flue Outlet Diameter	IN	6	6	8	10	10	12
	MM	152	152	203	254	245	305
G. To Center of Flue Outlet	IN	61.5	57.5	63	66	68	73
	MM	1562	1465	1600	1675	1728	1854
H. Feedwater Inlet	IN	33	33	33	34	34	34
	MM	838	838	838	865	865	865
I. Handholes	IN	18.5	18.5	19.5	19.5	19.5	19.5
	MM	470	470	495	495	495	495
J. Blowdown Outlet	IN	15.25	15	15	16.5	16.5	16.5
	MM	387	381	381	420	420	420
K. Water Column Extension	IN	14	14	14	14	14	14
	MM	355	355	355	355	355	355
L. Gas Train Extension (CSD-1)	IN	25	21.5	20.5	25	25	27
	MM	635	546	521	635	635	686
M. Clearance Required for Burner Removal	IN	94	86	108	111	110	121
	MM	2388	2184	2743	2819	2794	3073

**Weights**

Approx. Shipping Weight	LB	1900	2000	2280	3400	3500	4780
	KG	862	910	1036	1545	1591	2173

**All measurements are subject to +/- 0.5". Please refer to component drawings for actual measurements.**

**NOTE:** Recommended minimum clearance is 24" to the side and back of unit; 36" in front

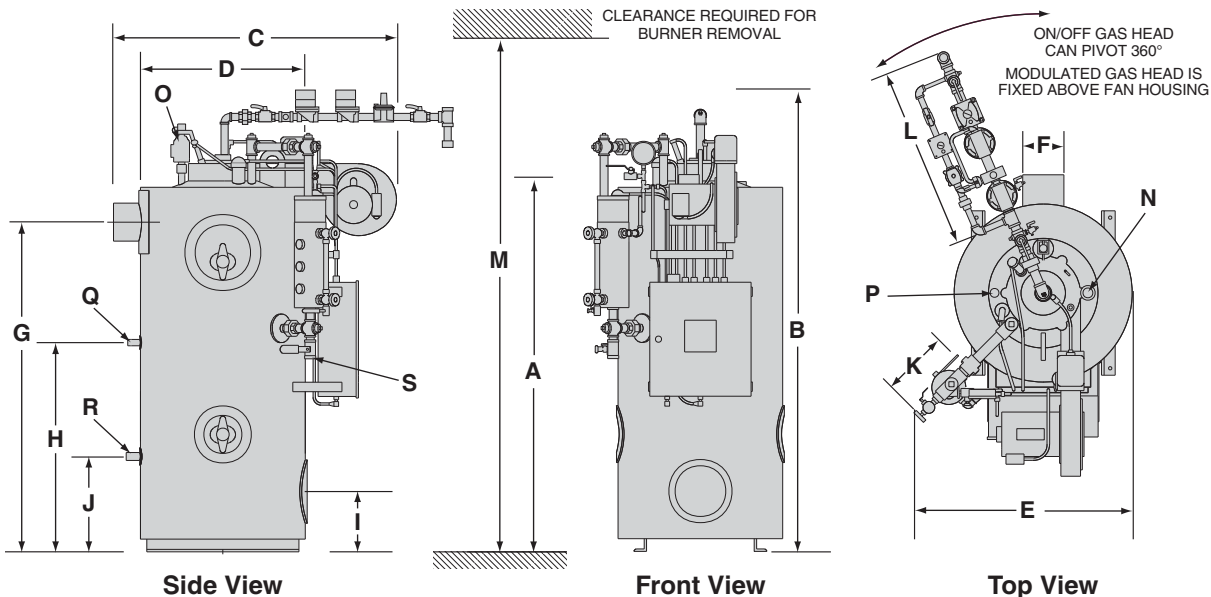

# Specifications

Models ICS/ICX/FB		9.5	10	15	20	25	30
<b>Boiler Connections</b>							
N. Steam Outlet 15 PSI		N/A	1.5" NPT	2" NPT	3" CL150# Flange	3" CL150# Flange	3" CL150# Flange
N. Steam Outlet 150 PSI		1" NPT	1" NPT	1.25" NPT	1.5" NPT	2" NPT	2" NPT
O. Safety Valve Outlet 15 PSI	IN MM	N/A	0.75 19	1 32	1.5 38	1.5 38	1.5 38
O. Safety Valve Outlet 150 PSI+ (9.5 HP 100 PSI)	IN MM	1 25	1 25	1 25	1 25	1 25	1 25
P. Safety Valve Inlet 15 PSI++	IN MM	N/A	0.75 19	1 25	1.25 32	1.25 32	1.25 32
P. Safety Valve Inlet 150 PSI (9.5 HP 100 PSI)	IN MM	0.75 19	0.75 19	0.75 19	0.75 19	0.75 19	0.75 19
Q. Feedwater Inlet	IN MM	1 25	1 25	1 25	1 25	1 25	1 25
R. Blowdown Outlet	IN MM	1 25	1 25	1 25	1.25 32	1.25 32	1.25 32
S. Water Column Blowdown	IN MM	1 25	1 25	1 25	1 25	1 25	1 25
Ratings* (Sea level to 3000 ft.)							
Output	1000 BTU/HR 1000 KCAL/HR	318 80.1	335 84.4	503 127	670 169	838 211	1005 253
Steam Output	LB/HR KG/HR	328 149	345 157	518 235	690 313	863 392	1035 470
Approximate Fuel Consumption at Rated Capacity+++							
Natural Gas (ICS) (9" - 13" w.c. req'd)	FT3/HR M3/HR	398 11.3	419 11.9	628 17.8	837 23.7	1047 29.7	1256 35.4
Natural Gas (ICX) (9" - 13" w.c. req'd)	FT3/HR M3/HR	384 10.8	403 11.4	606 17.2	807 22.9	1009 28.6	1210 34.3
Natural Gas Boiler Connection Size (Std CSD-1)	IN MM	1 25	1 25	1 25	1.25 32	1.25 32	1.5 38
Oil Inlet Size	IN MM	1/4 6	1/4 6	1/4 6	1/4 6	1/4 6	1/4 6
Burner Motor HP	3450 RPM/60 CY 2850 RPM/50 CY	.75 .75	.75 .75	1.5 1.5	1.5 1.5	1.5 1.5	1.5 1.5
Electric Power Requirements - Burner Only (in Amps) ***							
120V,60 CY, 1 Phase		9.2	9.2	--	--	--	--
240V, 50/60 CY, 1 Phase		4.6	4.6	8.9	8.9	8.9	8.9
208V, 50/60 CY, 3 Phase		3.1	3.1	4.4	4.4	4.4	4.4
240V, 50/60 CY, 3 Phase		2.8	2.8	4.2	4.2	4.2	4.2
480V, 50/60 CY, 3 Phase		1.4	1.4	2.1	2.1	2.1	2.1
Water Content							
	U.S. GAL LITERS	16 61	24 91	39 148	77 292	82 311	170 644

Specifications and Dimensions are approximate. We reserve the right to change specifications and/or dimensions. + High pressure boilers purchased with low pressure openings may have larger than specified opening sizes, consult factory for correct opening sizes. ++ 50 and 60 HP have two safety valves on low pressure. +++Consumption based on Natural Gas 1000 BTU/ft.<sup>3</sup>. \*All ratings from 0 PSIG and at 212 degrees F. \*\*\* Control circuit electrical requirement will vary with the system voltage, please consult factory. --Consult factory.



The Fulton Companies  
972 Centerville Road  
Pulaski, NY 13142  
Call 315-298-5121  
Fax 315-298-6390  
www.fulton.com

ffsle-pds-2011-1223

**LE**



## Starting the Gas Fired Boiler

See page 44-G

### Gas Burner Set Up

- a. Open the manual gas cocks on the pilot and main lines of the gas head.
- b. Switch on the main power to the burner. The water level relay is equipped with a manual reset. Depress the button on the box.
- c. The flame programmer is the main control in the panel box. The programmer in conjunction with a UV scanner "supervises" the ignition sequence - proves the flame is satisfactory, and finally "monitors" the established flame. Should any fault occur, either during the ignition sequence or during normal running, the programmer will immediately go to "lock-out" and the burner will shut down.
- d. When the pilot flame is established, the ultra-violet scanner senses the flame. This signal is transmitted back to the flame programmer which opens the main gas valve giving a main flame.
- e. If the installation is new or the burner has been disassembled, the burner may not fire at the first attempt due to air which must be purged from the gas lines. This will result in the burner flame programmer going to lockout. Repeat the procedure for starting the burner.
- f. The main gas valve will remain open as long as there is a demand for heat and the flame is carrying a sufficient signal to the flame programmer.
- g. If the flame is not established at the start, the safety switch in the flame programmer control will open the contacts and shut off the burner.
- h. Push the reset button on the control to reset. If trouble persists, it may be necessary to check the UV scanner. See Maintenance Section for procedure to check UV Scanner.

### Air adjustment for Fulton LE Gas Fired Steam Boilers.

- a. The primary air adjustment or main air control is located at the fan housing inlet. This control is used to supply the burner with air needed to facilitate good combustion. Too much or too little air will result in poor combustion. Using a CO<sub>2</sub> or O<sub>2</sub> tester, it is possible to determine the percent of excess air in the combustion mixture. Refer to Factory Test Fire Report for acceptable ranges.



**LE**



# LE Maintenance

---

## Pilot Adjustment for Fulton LoNOx Burner.

- a. Close downstream main shut off valve.
- b. Start boiler and check flame signal on pilot, lock programmer into pilot hold.
- c. Adjust gas regulator as needed to obtain a strong pilot signal.
- d. Slowly open downstream shut off valve and take the flame programmer off of hold.

## Main Flame Adjustment

- a. Place a combustion analyzer in the exhaust of the boiler.
- b. Adjust main gas regulator until last elbow pressure matches the test fire sheet.

**NOTE: Adjust air accordingly to ensure stable combustion during gas adjustments.**

- c. Adjust air setting until combustion readings are within specifications and stable combustion is present. Refer to Fulton test fire report for acceptable ranges.

## Burner Tile Replacement

- a. Remove scroll assembly.
- b. Break off top holding clips.
- c. Remove ceramic fiber burner tile.
- d. Replace burner tile bottom holding clips if needed.
- e. Replace with new burner tile.
- f. Carefully replace scroll assembly so that the ceramic fiber burner tile is not damaged.

# LE Maintenance

## Troubleshooting

a. The following troubleshooting guide will assist in the diagnosis and the correction of minor field problems. It contains instruction and information necessary to locate and isolate possible troubles which occur during normal operation. It

should be used in conjunction with the unit wiring diagram and the component literature provided in Section 7 of this manual.

b. The following lists cover the most common troubles that may occur on the Fulton gas fired boilers. Refer to left hand column of the chart to

locate the problem. Determine which cause, listed in the center column, that represents the problem by performing the corrective action as listed in the right hand column titled "REMEDY".

## Troubleshooting Gas-Fired Boilers

Problem	Cause	Remedy
<b>Ignition Failure</b>	1. Power Supply	Check fuse or circuit breaker. Reset or replace, as necessary.
	2. Ignition Electrodes	Check electrodes for carbon buildup and clean if necessary. Check for proper adjustments. Readjust if necessary. Check for cracks in porcelain. If found, replace.
	3. Transformer	Check voltage between transformer leads at terminal block to be sure transformer is being powered.
	4. Flame Safeguard Control	Check voltage between ignition terminal and neutral. Check must be made before control locks out on safety. If no power, replace control.
	5. Faulty Air Switch	Check for bad air switch by jumpering the two air switch leads at the terminal block. If the boiler starts and runs with these terminals jumpered, the air switch should be replaced.
	6. Gas Valve Sticking (Pilot)	Check for dirt in valve or orifice and clean if necessary. Check for faulty actuator or valve and replace if necessary.
	7. Gas Supply	Check for gas pressure and for intermittent supply problems. See test fire sheet for last elbow.
	8. Loose wire connection	Check connections to all components.
<b>Flame Failure</b>	1. Power Supply	Check fuse or circuit breaker. Reset or replace, as necessary.
	2. Gas Supply	Check for gas pressure and for intermittent supply problems.
	3. Ignition Electrodes	Check electrodes for carbon buildup and clean if necessary. Check for proper adjustment. Readjust if necessary. Check for cracks in porcelain; if found, replace.
	4. Primary Air Adjustment	Check air adjustment. Air may be blowing flame away from burner head.

# LE Maintenance

---

<b>Problem</b>	<b>Cause</b>	<b>Remedy</b>
<b>Flame Failure</b>	5. Scanner	Check for dirt on flame scanner and clean. Check for proper location of detector.
	6. Flame Safeguard Control	Check voltage at terminal leading to main gas valve. If no power, replace the control.
	7. Loose wire at fuel valve circuit	Tighten wiring connections.
	8. Contact open on air safety switch	Adjust to proper setting.
	9. Scanner wiring reversed at panel box	Change to correct terminals.
<b>Burner Cut-Off</b>	1. Power Supply	Check fuse or circuit; reset or replace, as necessary.
	2. Gas Supply	Check to be sure main gas cock is not closed. Check coil in gas valve with OHM meter. Replace if faulty. Check gas regulator setting and readjust as necessary. Check inlet gas pressure and increase or decrease as necessary.
	3. Ignition Electrodes	Check electrodes for carbon buildup and clean if necessary. Check for proper adjustment. Readjust if necessary. Check for cracks in porcelain; if found, replace.
	4. Scanner	Check for dirt on flame scanner and clean. Check for proper location of detector.
	5. Air Switch	Check for bad air switch by jumpering the two air switch leads as the terminal block. If the boiler starts and runs with these terminals jumpered, the air switch should be replaced.
	6. Gas Valve Sticking (Pilot)	Check for dirt in valve or orifice and clean if necessary. Check for faulty actuator or valve and replace if necessary.
	7. Weak Amplifier	Replace.
	8. Weak Pilot	Adjust to larger pilot by adjusting pilot gas pressure regulator.
	9. Faulty Liquid Level Control	Check to see if there is power to terminal number 10 when the sight glass shows the proper water level. If there is no power at this terminal, the control is bad and must be replaced.
	10. Dirty or defective UV Scanner	Clean or replace.

# LE Maintenance

---

<b>Problem</b>	<b>Cause</b>	<b>Remedy</b>
<b>Poor Combustion</b>	1. Refractories	Check refractories to see if they are plugged with soot or broken in pieces. Clean or replace as necessary.
	2. Air Adjustment	Check main air adjustment to see if it is loosened up. Adjust as necessary and tighten plate in position. Check CO <sub>2</sub> and O <sub>2</sub> levels.
	3. Draft	Check draft with a gauge. Draft should be a -.02" to -.04" W.C. with burner off or -.04" to -.06" when operating. May need to install a barometric damper.
	4. Dirty Flue	Check flue for carbon buildup or blockage. Clean flue passages with brush.
	5. Negative Room Pressure	Make sure no exhaust fans are running in the boiler room.
<b>Burner back fires</b>	1. Refractories	Check refractories to see if they are plugged with soot or broken in pieces. Replace as necessary.
	2. Ignition Electrodes	Check electrodes for carbon buildup and clean if necessary. Check for proper adjustment. Readjust if necessary. Check for cracks in porcelain; if found, replace.
	3. UV Scanner	Check for dirt on flame scanner and clean. Check for proper location of detector.
	4. Draft	Check draft with a gauge. Draft should be a -.02" to -.04" W.C. with burner off or -.04" to -.06" when operating. May need to install a barometric damper.
	5. Negative Room Pressure	Make sure no exhaust fans are running in the boiler room.
<b>Boiler will not maintain pressure</b>	1. Gas Supply	Check gas pressure coming into gas train. If low, contact gas company. Should be 7" to 11" W.C. Check coil in gas valve with AMP meter. Replace if bad. Check gas regulator setting and readjust as necessary.
	2. Dirty Flue	Check flue for carbon buildup or blockage. Clean flue passages with brush.
	3. Pressuretrol	Disconnect all power to the controller. Disconnect the wires from the controller. Put an OHM meter between the switch terminals. Lower the set point and recheck with OHM meter. Switch should break. If the controller operates improperly, replace it.
	4. Scale Built up in boiler	Refer to Section 2 "Pressure Vessel Cleaning".
	5. Refractories	Check refractories to see if they are cracked or broken in pieces. Replace as necessary.
	6. Steam traps blowing through	Check traps to see if they are clean or replace as necessary.
	7. Boiler size	Boiler may be undersized.

# LE Maintenance

---

<b>Problem</b>	<b>Cause</b>	<b>Remedy</b>
<b>Boiler is Surging</b>	1. Steam traps blowing through	Check traps to see if they are clean or replace as necessary.
	2. Perc (cleaning solvent in boiler)	Clean boiler with washing soda per instruction manual.
	3. Scale build-up or lime deposits	Call water treatment professional and consult factory.
	4. Too much compound in system (water treatment)	Dump return tank and flush system. Have water tested by water treatment company.
	5. Too much water softener (high PH)	Have water tested by water treatment company.
	6. Too much of a load	Check total equipment horsepower required against horsepower of boiler being used. Decrease amount of equipment being used at one time.
	7. Boiler new (not cleaned)	Clean per instructions in instruction manual.
<b>Boiler Rumbles and Pulsates</b>	1. Draft problem	Check draft with a gauge. Draft should be a $-.02''$ to $-.04''$ W.C. with burner off or $-.04''$ to $-.06''$ when operating. May need to install a barometric damper.
<b>Boiler pushing water with the steam</b>	1. Steam Traps	Check traps. Clean or replace as necessary.
	2. Too much boiler compound	Dump return tank and flush system. Have water tested by water treatment company.
<b>Pump will not cut off</b>	1. Dirty Probes	Clean or replace as necessary.
	2. Relay failed	Make sure relay is plugged in tightly. If so, replace water level relay.
	3. Ground Connection	Check for tightness and clean.
<b>Pump runs but does not put water into boiler</b>	1. Vapor locking of pump	Allow system to cool down, check steam traps and check to be sure return lines are not insulated. Check return tank temp. If it is above $180^{\circ}\text{F.}$ , ( $82^{\circ}\text{C.}$ ) vapor locking of pump will occur. Inspect check valves. Clean and replace as needed. Replace pump with multistage centrifugal good for $250^{\circ}\text{F.}$ ( $121^{\circ}\text{C.}$ ).
	2. Impeller Adjustment	Check for impeller wear and adjust per component information in instruction manual (Burks only).
	3. Back pressure on pump	Need to install repair kit on pump.
	4. Plugged feed water nipple	Check and clean or replace as necessary.

# LE Maintenance

---

<b>Problem</b>	<b>Cause</b>	<b>Remedy</b>
<b>Water pump will not come on at times</b>	1. Scale on probes	Check and clean or replace as necessary.
	2. Bad Pump Contactor	Check to see if contactor is being powered. Check to see if contactor coil is pulling in. Replace if necessary.
	3. Bad Pump Motor	Check the incoming power to the pump to be sure it is receiving power. If power is present but motor does not run, replace it.
<b>Low Fuel pressure</b>	1. Gas pressure regulator	Check and replace.
<b>Boiler Flooding</b>	1. Pump does not shut off	Dirty probes. Clean or replace as necessary.
	2. Relay failed	Make sure relay is plugged in tightly. If so, replace water level relay.
	3. Ground Connection	Check for tightness and clean.
	4. Vacuum created with boiler off	As the boiler cools off, it pulls water from the system piping. To prevent this, add a 1/4" check valve on the steam gauge assembly piping, which closes under pressure and opens under vacuum.

---

**LE**



# LE Parts

## Spare Parts

- a. It is important that the correct replacement part is fitted to your Fulton Gas Fired Steam Boiler.
- b. When ordering replacement or spare parts, make sure that the full

information given in the Parts List is supplied, together with the following details as shown on your boiler identification plate:

1. Boiler Number
2. Boiler Type
3. Electrical Specifications

## NOTE:

**The policy of Fulton Boiler Works, Inc. is one of continuous improvement, and therefore, we reserve the right to change prices, specifications, and equipment without notice.**

## Replacement Parts Listing (available from authorized Fulton Representative)

Part No.	Description	Approx. Net Weight (lbs.)	Approx. Net Weight (kgs.)
2-12-219	Furnace Burner Tile (9.5 HP)	2	.91
2-12-253	Furnace Burner Tile (10 HP)	2	.91
2-12-221	Furnace Burner Tile (15 HP)	2	.91
2-12-254	Furnace Burner Tile (20-30 HP)	15	6.8
5-21-6009	Burner Scroll (9.5 HP)	30	13.6
5-21-6010	Burner Scroll (10 HP)	45	20.4
5-21-6015	Burner Scroll (15 HP)	55	24.9
5-21-6030	Burner Scroll (20 HP)	65	29.5
5-21-6031	Burner Scroll (30 HP)	65	29.5
2-30-1330	Blower Assembly (9.5 - 10 HP)	22	9.98
2-30-1331	Blower Assembly (15 - 20 HP)	30	13.6
2-30-1339	Blower Assembly (30 HP)	35	15.9
2-20-18	Ignition Electrode (9.5 - 10 HP)	.5	.23
2-20-30	Ignition Electrode (15, 20, 30 HP)	.4	.18
5-10-610	Burner Assembly LoNOx (9.5 - 10 HP)	35	15.9
7-30-571	Burner Assembly LoNOx (15 HP)	45	20.4
7-30-672	Burner Assembly LoNOx (20 HP)	55	24.9
7-30-673	Burner Assembly LoNOx (30 HP)	55	24.9
2-30-819	O ring for Pilot Tube LoNOx - 1.76 ID x .070)	.01	.005
2-30-813	O ring for Pilot Tube LoNOx - 8.7 mm x 1.78 mm)	.01	.005
2-40-631	Temperature Limit LoNOx	3	1.37
2-40-803	Thermocouple High Limit LoNOx	.2	.09



# 2



# Description/Instructions

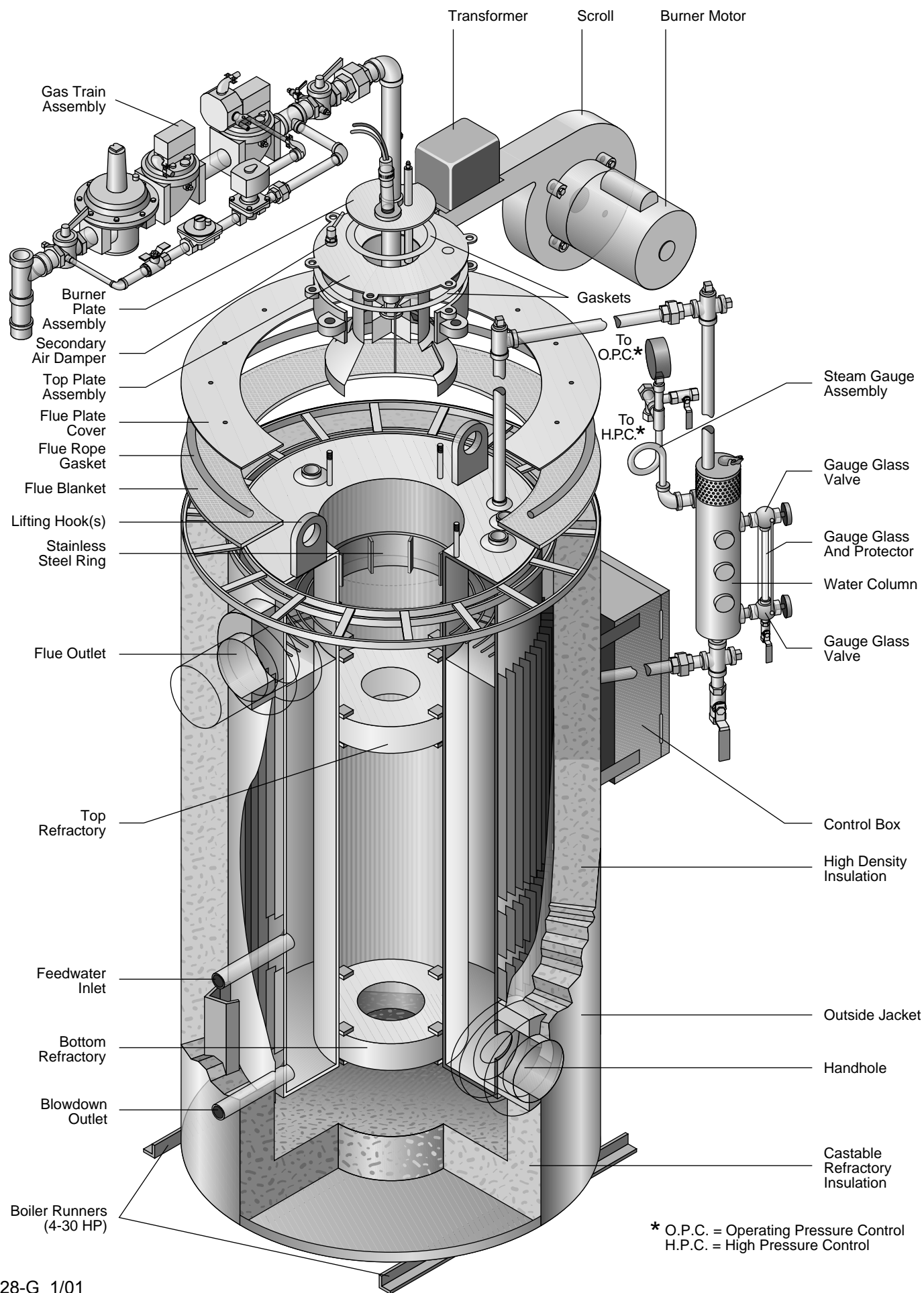



**Product Data Submittal**  
**Fulton Models: ICS/FB-A and ICX/FB-F**

**Fulton Gas & Oil Fired**  
**Vertical Tubeless**  
**Steam Boilers**  
**(Standard Burner)**

**Dimensions**

Standard Models ICS/FB-A Models ICX/FB-F		4	6	9.5	10	15	20	25	30	50	60
Unit Size:	BHP	4	6	9.5	10	15	20	25	30	50	60
A. Boiler Height	IN	47.5	57.5	67.5	63.5	69.5	72.5	75	82.5	87.5	93.5
	MM	1207	1461	1715	1613	1765	1842	1905	2069	2223	2375
B. Boiler Height With Trim* & Fuel Train Assembly	IN	65	75	85	80.5	86.5	92.5	95	102	106.5	120
	MM	1651	1905	2159	2045	2197	2350	2413	2591	2705	3048
C. Overall Depth Stack to Burner Fan Housing	IN	44	44	44	46	47	58	59	67	78	78
	MM	1118	1118	1118	1168	1194	1474	1499	1702	1981	1981
D. Boiler Diameter	IN	26	26	26	28	30	39	39	46	55	55
	MM	660	660	660	710	760	990	990	1170	1400	1400
E. Overall Width with Water Column	IN	33	33	33	33.5	35.5	43	43	49	57	57
	MM	838	838	838	851	902	1091	1091	1244	1448	1448
F. Flue Outlet Diameter	IN	6	6	6	6	8	10	10	12	12	12
	MM	152	152	152	152	203	254	245	305	305	305
G. To Center of Flue Outlet	IN	42	52	62	58	63	66	68	73.5	79	85
	MM	1070	1320	1575	1473	1600	1675	1728	1867	2007	2159
H. Feedwater Inlet	IN	27	33	33.5	33	33.5	34	34	34	35	35
	MM	685	840	851	840	851	865	865	865	890	890
I. Handholes	IN	19	19	19	19	19	19	19	19	20	20
	MM	485	485	485	485	485	485	485	485	510	510
J. Blowdown Outlet	IN	15	15	15.5	15.5	15.5	16.5	16.5	16.5	17.5	17.5
	MM	380	380	394	394	394	420	420	420	445	445
K. Water Column Extension	IN	14	14	14	14	14	14	14	14	14	14
	MM	355	355	355	355	355	355	355	355	355	355
L. Gas Train Extension (CSD-1)	IN	22.5	22.5	25	21.5	20.5	25	25	27	22.5	34
	MM	572	572	635	546	521	635	635	686	572	867
M. Clearance Required for Burner Removal*	IN	72	82	92	86	92	96	98	106	114	124
	MM	1828	2083	2337	2184	2337	2438	2490	2692	2896	3150
<b>Weights</b>											
Approx. Shipping Weight	LB	1400	1700	1900	2000	2280	3400	3500	4780	6526	7280
	KG	635	773	862	910	1036	1545	1591	2173	2966	330
Approx. Operating Weight	LB	1516	1833	2200	2200	2605	4042	4184	6197	8569	9531
	KG	688	831	998	998	1182	1833	1898	2811	3887	4323

\*This dimension is 6" less for oil fired units 4-50 HP and 12" less for oil fired units 60 HP.  
**NOTE:** Recommended minimum clearance is 24" to the side and back of unit; 36" in front

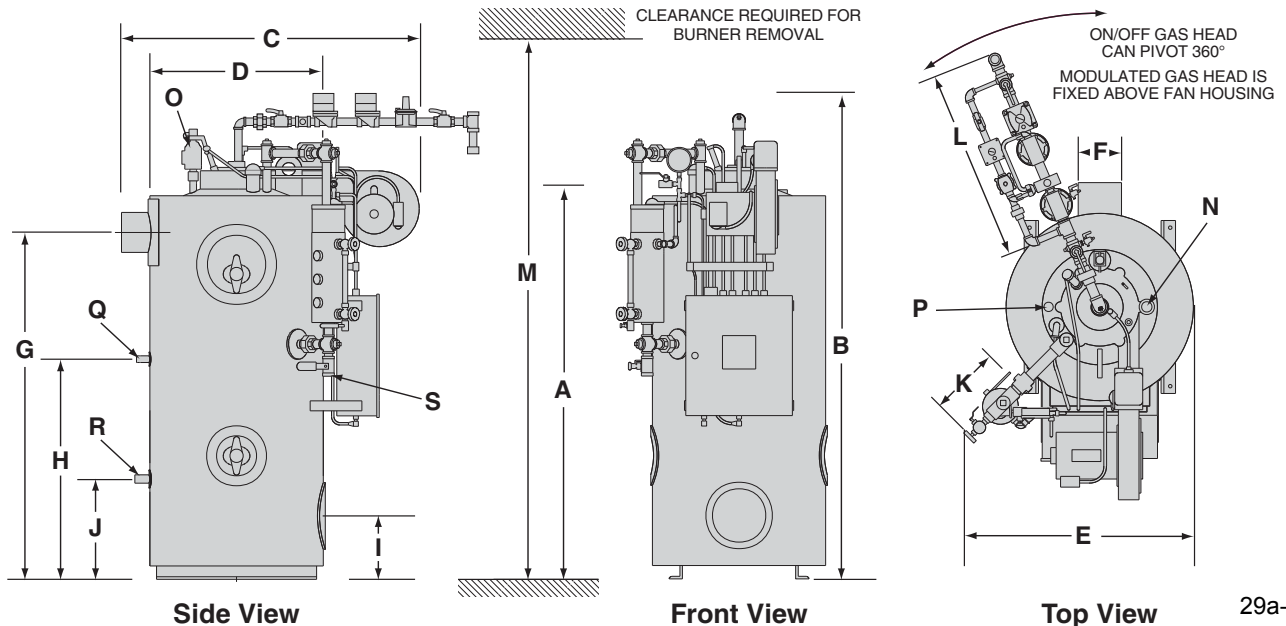

# Specifications

Models ICS/ICX/FB		4	6	9.5	10	15	20	25	30	50	60
<b>Boiler Connections</b>											
N. Steam Outlet 15 PSI		1" 25	1" NPT	N/A	1.5" NPT	2" NPT	3" CL150# Flange	3" CL150# Flange	3" CL150# Flange	4" CL150# Flange	4" CL150#
N. Steam Outlet 150 PSI		0.75" 19	0.75" NPT	1" NPT	1" NPT	1.25" NPT	1.5" NPT	2" NPT	2" NPT Flange	3" CL150# Flange	3" CL150#
O. Safety Valve Outlet 15 PSI	IN MM	0.75 19	0.75 19	N/A	0.75 19	1 32	1.5 38	1.5 38	1.5 38	2 38	2 38
O. Safety Valve Outlet 150 PSI+ (9.5 HP 100 PSI)	IN MM	1 25	1 25	1 25	1 25	1 25	1 25	1 25	1 25	1.25 32	1.25 32
P. Safety Valve Inlet 15 PSI++	IN MM	0.75 19	0.75 19	N/A	0.75 19	1 25	1.25 32	1.25 32	1.25 32	1.5 32	2 32
P. Safety Valve Inlet 150 PSI (9.5 HP 100 PSI)	IN MM	0.75 19	0.75 19	0.75 19	0.75 19	0.75 19	0.75 19	0.75 19	0.75 19	1 25	1 25
Q. Feedwater Inlet	IN MM	0.75 19	0.75 19	1 25	1 25	1 25	1 25	1 25	1 25	1 25	1 25
R. Blowdown Outlet	IN MM	1 25	1 25	1 25	1 25	1 25	1.25 32	1.25 32	1.25 32	1.5 38	1.5 38
S. Water Column Blowdown	IN MM	1 25	1 25	1 25	1 25	1 25	1 25	1 25	1 25	1 25	1 25
<b>Ratings* (Sea level to 3000 ft.)</b>											
Output	1000 BTU/HR	134.40	201	318	335	503	670	838	1005	1674	2009
	1000 KCAL/HR	33.8	50.7	80.1	84.4	127	169	211	253	422	506
Steam Output	LB/HR	138	207	328	345	518	690	863	1035	1725	2070
	KG/HR	63	94	149	157	235	313	392	470	785	942
<b>Approximate Fuel Consumption at Rated Capacity+++</b>											
Light Oil	GPH	1.2	1.8	2.8	3.0	4.5	6.0	7.5	9.0	15.0	17.9
	LPH	4.5	6.8	10.6	11.4	17	22.7	28.4	34.1	56.8	67.8
Propane Gas (ICS)	FT3/HR	67.2	100	159	168	251	335	419	502	837	1004
(14" w.c. req'd)	M3/HR	1.9	2.8	4.5	4.8	7.1	9.5	11.9	14.2	23.7	28.4
Propane Gas (ICX)	FT3/HR	63	97		161	242	323	404	484		
(14" w.c. req'd)	M3/HR	2.2	2.7	N/A	4.6	6.9	9.1	11.4	13.7		
Natural Gas (ICS)	FT3/HR	168	257	398	419	628	837	1047	1256	2093	2511
(7" - 11" w.c. req'd)****	M3/HR	4.8	7.1	11.3	11.9	17.8	23.7	29.7	35.4	59.3	71.1
Natural Gas (ICX)	FT3/HR	159	242	384	403	606	807	1009	1210		
(7" - 11" w.c. req'd)****	M3/HR	5.6	6.9	10.8	11.4	17.2	22.9	28.6	34.3		
Natural Gas Boiler	IN	1	1	1	1	1	1.25	1.25	1.5	1.5	2
Connection Size (Std CSD-1)	MM	25	25	25	25	25	32	32	38	38	51
Oil Inlet Size	IN	1/4	1/4	1/4	1/4	1/4	1/4	1/4	1/4	1/4	1/4
	MM	6	6	6	6	6	6	6	6	6	6
Burner	3450 RPM/60 CY						1/3 gas	1/3 gas		1.5 gas	1.5 gas
Motor HP	2850 RPM/50 CY	1/3	1/3	1/3	1/3	1/3	3/4 oil	3/4 oil	3/4	2 oil	2 oil
<b>Electric Power Requirements - Burner Only (in Amps) ***</b>											
120V, 60 CY, 1 Phase		5.2	5.2	5.2	5.2	5.2	5.2 gas 9.2 oil	5.2 gas	9.2	--	--
240V, 50/60 CY, 1 Phase		2.6	2.6	2.6	2.6	2.6	2.6 gas 4.6 oil	2.6 gas	4.6 9.5 oil	8.9 gas 9.5 oil	8.9 gas
208V, 50/60 CY, 3 Phase		1.9	1.9	1.9	1.9	1.9	1.9 gas 3.1 oil	1.9 gas	3.1 5.7 oil	4.4 gas 5.7 oil	4.4 gas
240V, 50/60 CY, 3 Phase		1.6	1.6	1.6	1.6	1.6	1.6 gas 2.8 oil	1.6 gas	2.8 5.4 oil	4.2 gas 5.4 oil	4.2 gas
480V, 50/60 CY, 3 Phase		0.8	0.8	0.8	0.8	0.8	0.8 gas .4 oil	0.8 gas	1.4 2.7 oil	2.1 gas 2.7 oil	2.1 gas
<b>Water Content</b>											
	U.S. GAL	14	16	16	24	39	77	82	170	245	270
	LITERS	53	61	61	91	148	292	310	644	927	1022

Specifications and Dimensions are approximate. We reserve the right to change specifications and/or dimensions. + High pressure boilers purchased with low pressure openings may have larger than specified opening sizes, consult factory for correct opening sizes. ++ 50 and 60 HP have two safety valves on low pressure.

+++Consumption based on light Oil 140,000 BTU/G; Natural Gas 1000 BTU/ft.<sup>3</sup>; Propane 2500 BTU/ft.<sup>3</sup>. \*All ratings from 0 PSIG and at 212 degrees F. \*\*\* Control circuit electrical requirement will vary with the system voltage, please consult factory. --Consult factory.

\*\*\*\*ICS-50 & 60 have a minimum gas pressure requirement of 9" w.c



The Fulton Companies  
972 Centerville Road  
Pulaski, NY 13142  
Call 315-298-5121  
Fax 315-298-6390  
www.fulton.com

ffsstd-pds-2011-1222

# Description/Instructions

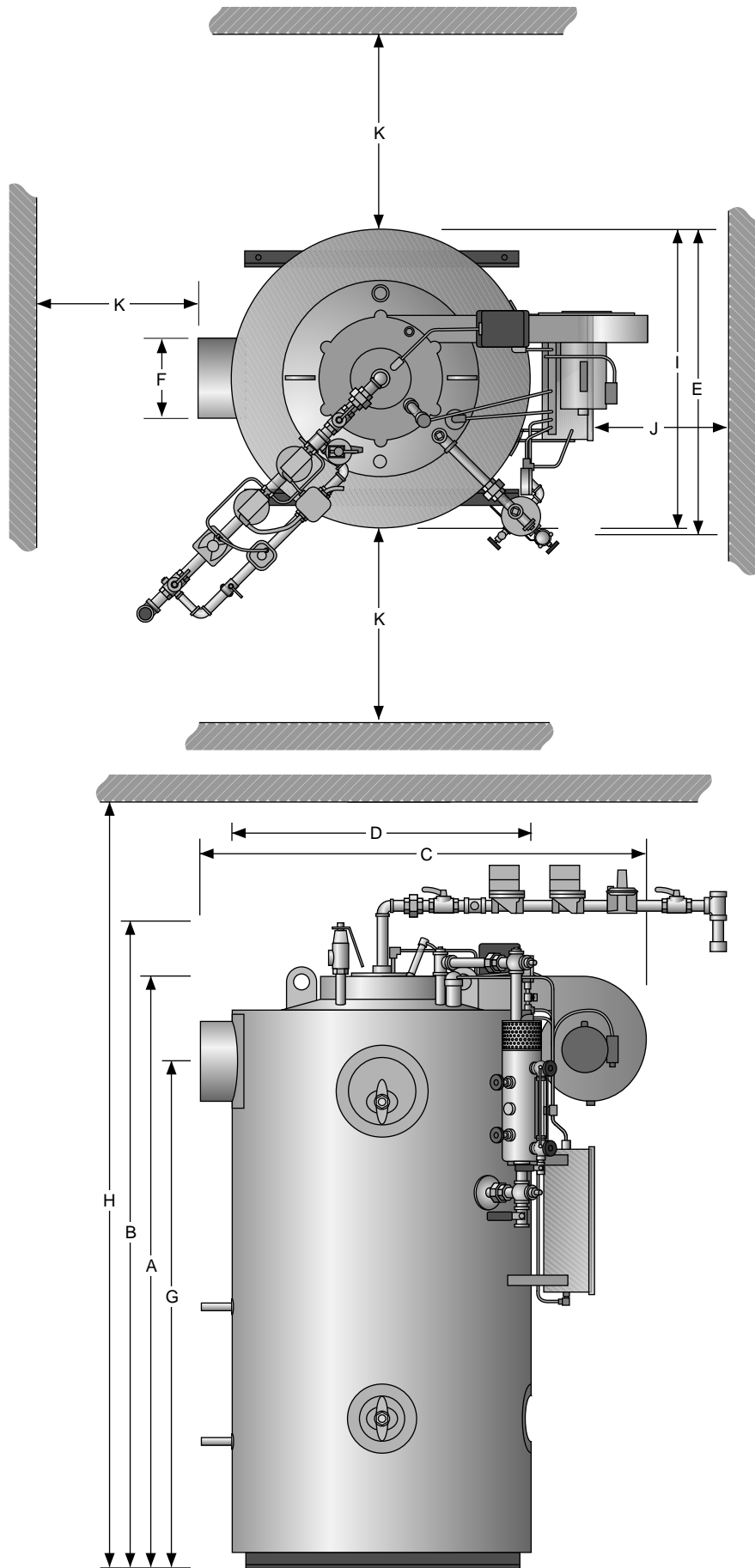



# Description/Instructions

## Basic Boiler, Condensate Tank, and Blow off Separator

### NOTE

Where a condensate return tank is to be fitted, this should:

- 1) Be vented to a safe location, and
- 2) Have a capacity sufficient to satisfy boiler consumption as well as maintain proper return tank temperature.
- 3) Vent pipe should not be down-sized (this may cause pressure build up in the condensate tank).
- 4) Return pipes must not be insulated. This can cause overheating the return system, causing a vapor lock in the pump.
- 5) See Return System Instruction Manual for detailed instructions.

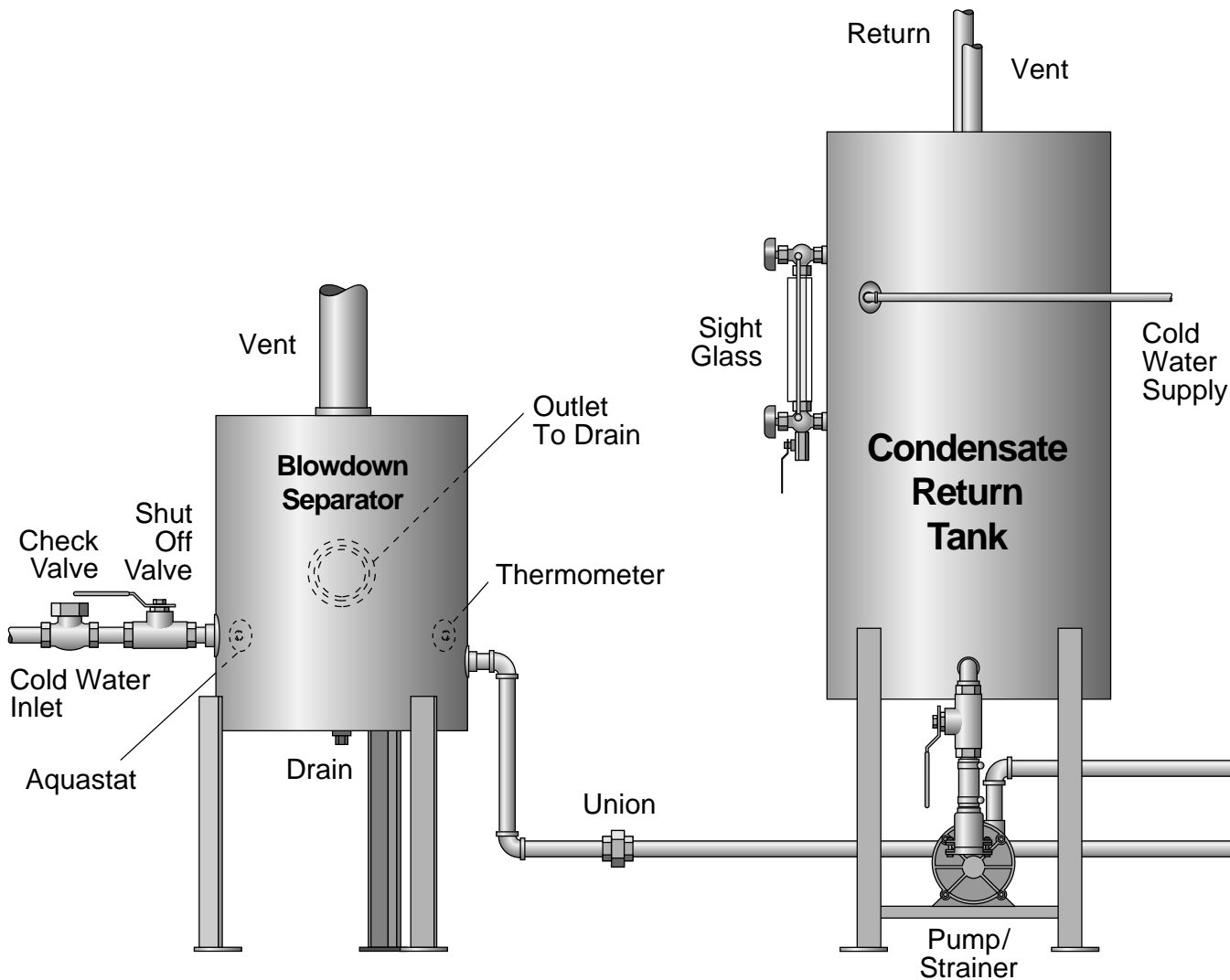

# Description/Instructions

## NOTE

Care should be taken to ensure that the blow off receptacle used meets the regulations covering such vessels. If in doubt consult a Fulton Representative for advice.

a) Make sure two check valves are installed between the boiler and pump (one check valve is supplied with the unit).

b) In a closed system an end of the line trap should be installed.

c) There are three blow off valves on the boiler: the main valve at the rear of the boiler, the gauge glass blow off valve, and the water column blow off valve. The boiler blow off valve supplied with the boiler should be screwed to the blow off pipe at the rear of the boiler and

connected to a blow off receptacle of approved design.

All these procedures should be done in accordance with state and/or local codes. The water column blow off valve and the gauge glass blow off valve should be connected to the main blow off line.

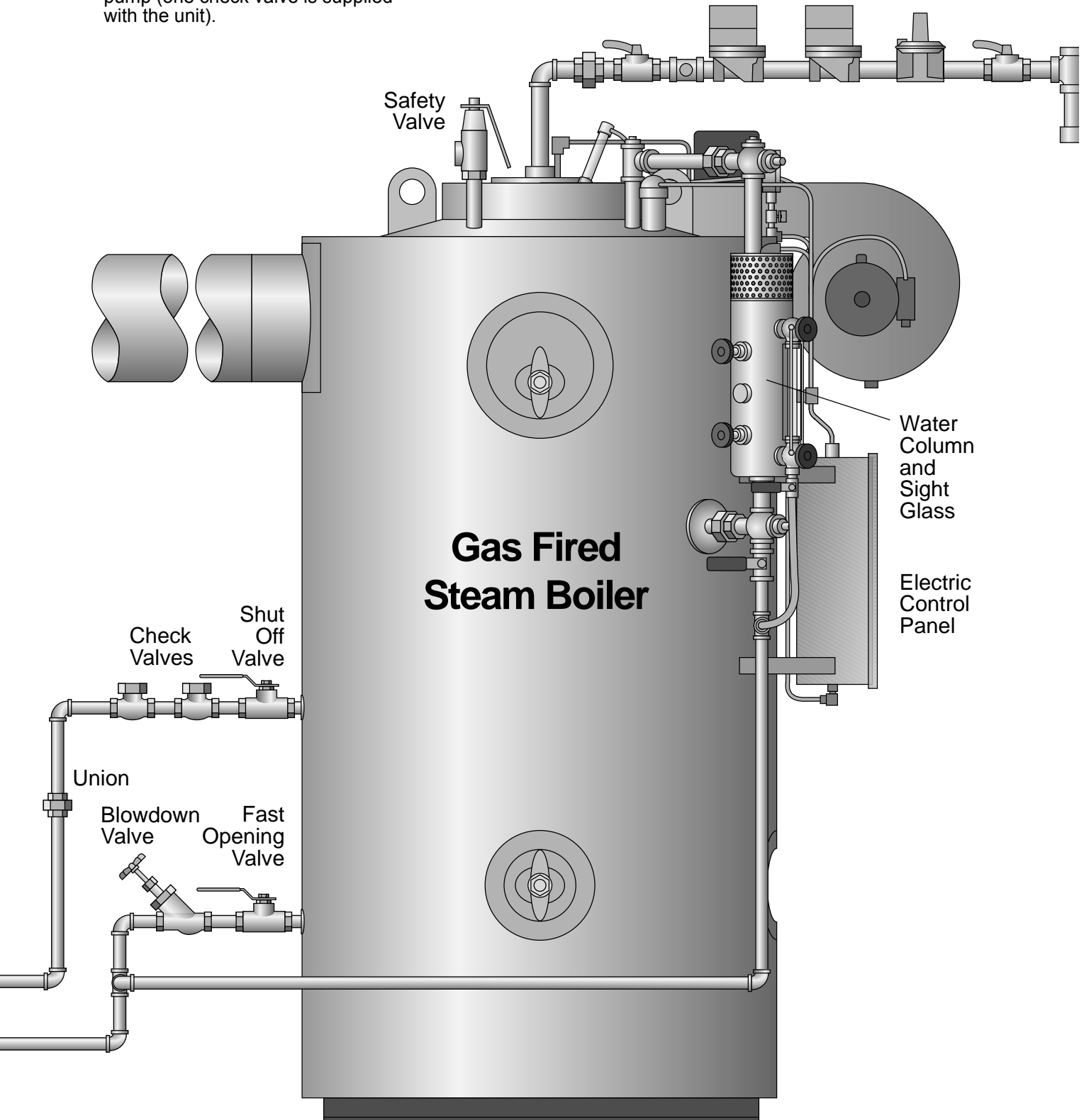

# Description/Instructions

## Boiler Installation

**The Steam Supply** — Pipe the steam supply line from the top right side of the boiler.

## The Steam Safety Valve

1) Before installing, be sure that all pipes and connections have been blown clean. Pipe compound or dope is used on external threads only. Be sure inlet of valve is free of any foreign material.

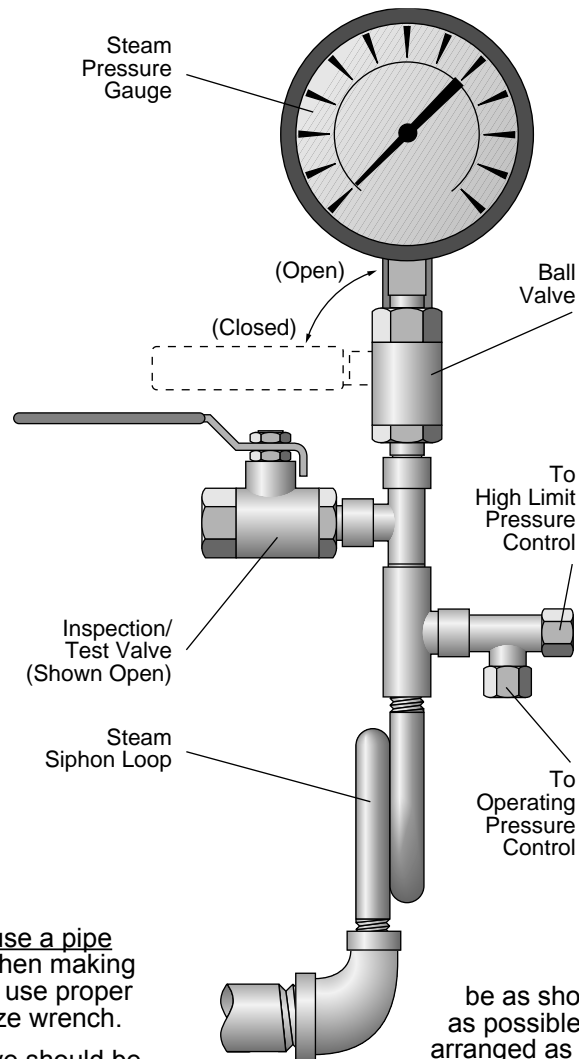

- 2) Do not use a pipe wrench! When making installation, use proper type and size wrench.
- 3) The valve should be installed in a vertical upright position in the connection provided on the top left side of the boiler with no unnecessary intervening pipe. Under no circumstances should there be a shut off valve or restriction of any kind between the safety valve and the connection provided.
- 4) Do not cap or plug drain hole in the side of valve body.
- 5) Since the purpose of this safety valve is to protect against an overpressure situation, it will loudly discharge hot steam in doing so. Therefore, it is recommended that a discharge pipe be securely installed and run to a safe point of disposal.
- 6) When a discharge pipe is used, it must be of a pipe size equal to or greater than that of the valve outlet. Use schedule 40 discharge pipe only. Do not use schedule 80, extra strong or double extra strong discharge pipe or connections. It must

be as short and straight as possible and so arranged as to avoid undue stress on the valve. It must have an ample provision for draining condensate at or near the valve outlet. It must terminate freely to atmosphere with no intervening valve of any description and it must be securely anchored and supported.

**The Steam Pressure Gauge Assembly** — The gauge should be facing front towards the panel box and/or operator of the boiler.

Except as noted, each assembly or any of its component parts may be oriented, other than as shown to provide improved operating clearances and/or view of gauge. Before installing steam gauge on the siphon, add a small amount of water to the siphon to create a water seal to buffer the gauge element. This must be done to prevent inaccurate pressure readings and /or premature failure of the gauge. Install the steam gauge into the siphon on the water column.

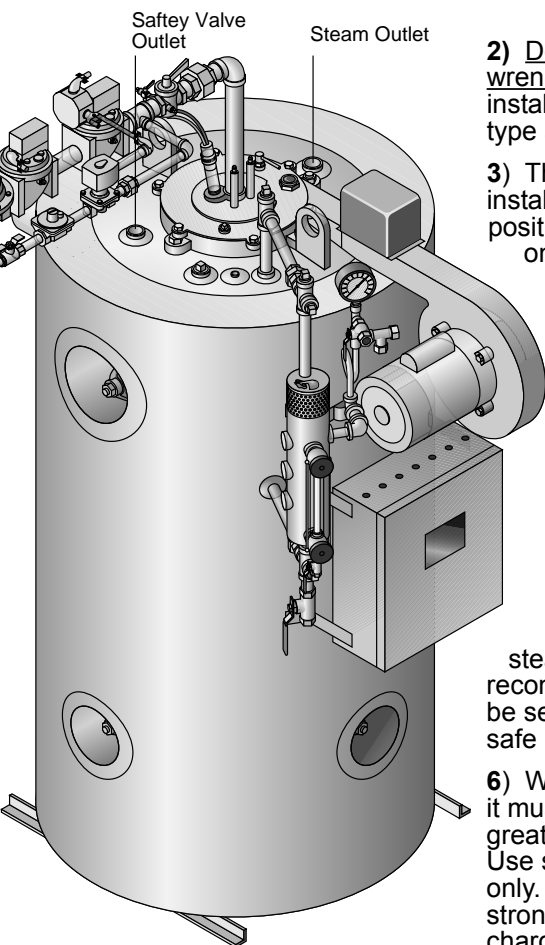

# Description/Instructions

**The Blow-Off Valve** — There are two blow off valves on the boiler: The main valve at the rear of the boiler and the water gauge glass blow off valve. The boiler blow off valve supplied with the boiler should be screwed to the blow off pipe at the rear of the boiler and connected to a blow off receptacle of approved design. This should be done in accordance with state and local codes.



## The Feed Water Piping

1) Provisions must be made for adequate water supply and properly sized piping. Piping must be done in compliance with all local codes. The following chart may be used as a guideline for sizing.

BHP	Minimum Water Supply Piping Size	
	Inches	Millimeters
6	1/2	12.5
9.5	1/2	12.5
10	1/2	12.5
15	3/4	19
20	3/4	19
30	1	25
40	1	25
50	1	25
60	1	25
4	1/2	12.5

2) When feeding the boiler using a return system, the city water pressure should not exceed 40 PSI. A pressure reducing valve should be installed a head of the return tank when above this pressure.

3) It is important that all piping be lined up and not forced into place. It is recommended that you begin piping at the pump. If the lines are ended at the pump, particularly if the last piece is cut too short or long, the pump will be forced to meet the pipe and strain or distortion will result.

4) Do not use the pump as a piping support. It is critical that the pipe be independently supported near the pump so no strain will be transmitted to the unit.

5) Connect the feed water stop valve to the feed water pipe at the rear of the boiler and pipe it to the return system.

## The Water Column

Install the piping from the water column and water gauge glass to a safe blow-off point.



# Description/Instructions

## Water Gauge & Gauge Glass Installation instructions

### NOTE

Only properly trained personnel should install and maintain water gauge glass and connections. Wear safety glasses during installation. Before installing, make sure all parts are free of chips and debris.

### NOTE

Keep gauge glass in original packaging until ready to install.

- 1) Verify the proper gauge has been supplied.
- 2) Examine the gauge glass and packings carefully for damage before installation. Do not use the glass if it contains any scratches, chips, or any other visible signs of damage.
- 3) Do not subject the gauge glass to bending or torsional stresses.
- 4) Apply teflon tape or pipe dope to pipe threads. Install top gauge fitting (fitting without a drain valve) into the uppermost tapping. Wrench tighten the fitting until it is snug and the glass outlet is pointing at five o'clock (about 1/8 turn from its final downward vertical position).
- 5) Install the bottom gauge fitting (the fitting with a drain valve) until it is snug and the glass outlet is pointing directly upward. Verify top and bottom fittings are threaded into the tapings the same number of turns (distance A=distance B).
- 6) Remove glass packing nut, friction washer and glass packing from the fittings, and place them, in the same order, on to both ends of the gauge glass. Push both packings about an inch up the gauge glass.
- 7) Gently insert one end of the glass into the top gauge fitting. Keeping the glass inside the top fitting, gently rotate the top gauge fitting clockwise until vertically aligned with the bottom gauge fitting, then inset glass into bottom fitting until glass bottoms out on the shoulder inside the bottom fitting.
- 8) Carefully raise glass about 1/16" and slide lower glass packing down until the glass packing contacts the lower gauge fitting. **DO NOT** allow the glass to remain in contact with any metal!

9) Carefully slide upper glass packing up as far as possible.

10) Hand tighten both glass packing nuts, then tighten 1/2 turn more by wrench. Tighten only enough to prevent leakage. **DO NOT OVERTIGHTEN!** If any leakage should occur, tighten slightly, a quarter turn at a time, checking for leakage after each turn.

11) Install the protective guard, and utilize automatic ball checks where necessary to help prevent injury in case of glass breakage.

### WARNING

Improper installation or maintenance of gauge glass and connections can cause immediate or delayed breakage resulting in bodily injury and/or property damage.

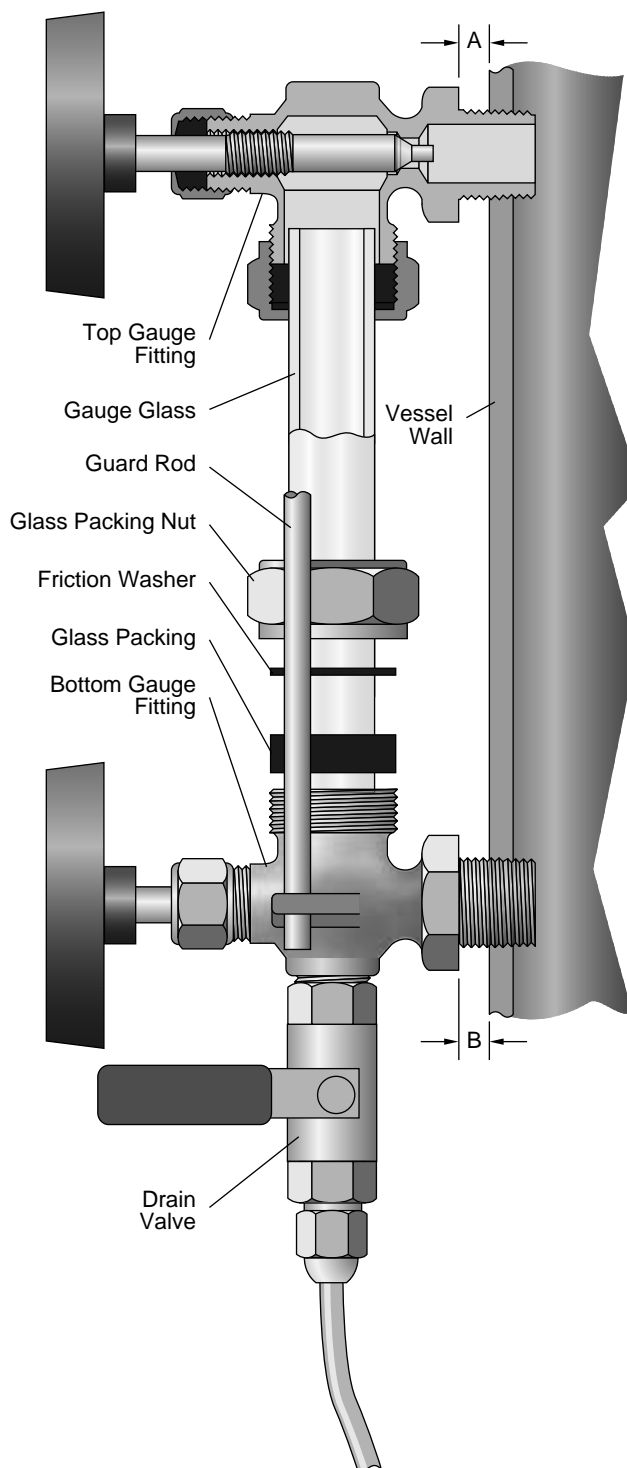

# Description/Instructions

## Water Supply

a) Feed water contains solids and dissolved gases. These may promote incrustation of scale; foaming, priming, surging, and solids in steam; corrosion and pitting; or caustic embrittlement. To prevent this, feedwater must be studied individually and treated accordingly by reputable professionals specializing in this field. It is strongly recommended that a competent water treatment company be consulted prior to the installation of the boiler.

b) The purpose of this treatment should be to provide quality feedwater to the boiler such that corrosion and deposition in the boiler will be minimized. Dissolved oxygen, high chloride levels and low pH can all be major causes of corrosion. Untreated hardness is the major cause of deposits. Poor quality feedwater requires increased blow off and increased chemical treatment costs to prevent boiler corrosion and scaling.

c) One way to lower the amount of dissolved oxygen in the boiler feed water is the sparge tube option. This option injects live steam into the feedwater to increase the water temperature to 180 degrees F (82 degrees C) which removes oxygen from the water.

d) Chlorides can be controlled by increasing the number of blow downs per day from one to four.

e) **The Fulton Warranty does not cover damage or failure that can be attributed to corrosion, scale or dirt accumulations. Oxygen is a corrosive.** See the Warranty Section of this manual for full details.

## Recommended Water Treatment

a) Following are recommendations for feed water and boiler water. Contact your local water treatment professional for testing and treatment recommendations. It is very important that a strict water treatment program be followed.

### Feedwater:

Dissolved Oxygen .....	less than 0.05 ppm
pH Value .....	9-11 (tested at room temperature)
*Hardness.....	less than 70 ppm in the form of CaCO <sub>3</sub>
Oil.....	none
Suspended Solids .....	none
Organic Matter .....	less than 5.0 ppm
Chloride .....	less than 50.0 ppm
Total Dissolved Solids .....	less than 300ppm

### Boiler Water:

Phosphate.....	30 to 50 ppm in the form of PO <sub>4</sub>
Alkalinity .....	less than 300 ppm in the form of CaCO <sub>3</sub>
Chloride.....	less than 500 ppm
pH Value.....	9 to 11 tested at room temperature)
Total Dissolved Solids.....	400 to 2,000 ppm
Iron.....	1 ppm maximum
Silica .....	180 ppm max. as SiO <sub>2</sub>
Hardness.....	less than 50.0 ppm
Dissolved Oxygen.....	none

ppm = parts per million; CaCO<sub>3</sub>=Calcium Carbonate; PO<sub>4</sub>=Phosphate; SiO<sub>2</sub>=silicon dioxide; \* 1 Grain Hardness = 17.118 ppm Therefore: 70 ppm = 4.10 grains hardness

b) It is critical that the boiler pH be alkaline (9-11) whenever water is in the boiler. Solids that enter in with the feed water concentrate in the boiler. Daily boiler blow down is recommended to prevent corrosion and/or deposits from forming.

### Glossary of Water Supply Corrosives and Inhibitors

**Dissolved Oxygen:** Oxygen that is dissolved in the feedwater will cause the steel in the boiler and the feedwater system to be attacked by the water in a manner described as "pitting". The pits that are produced can vary from tiny depressions to holes large enough to penetrate the boiler metal and are usually covered with tubercles of iron oxide. Once pitting starts, it may be extremely hard to arrest. Pitting can proceed at a surprisingly rapid rate and can occur not only in the boiler proper, but also in pre-boiler equipment such as economizers, feedwater heaters, and feedwater lines.

**Sodium Sulfite:** Its purpose is to chemically remove the dissolved oxygen left in the feedwater.

Sodium Sulfite reacts chemically with dissolved oxygen, producing sodium sulfate. Since it is desirable to remove dissolved oxygen from the feedwater before it reaches a boiler. Sodium sulfite is best introduced continuously at some suitable point in the feedwater system. Chemical residual control is based on the maintenance of a specific excess of sodium sulfite in the boiler water. The essential requirement being to maintain in the feedwater at all times slightly more than enough sodium sulfite to consume all of the dissolved oxygen. When sodium sulfite is not fed contin-

uously, protection of the boiler against oxygen attack must depend on the reserve of sodium sulfite that is present in the boiler water. In this case, it is important that the feedwater and the boiler water are mixed thoroughly and as quickly as possible so that boiler water sodium sulfite may consume feedwater oxygen before the latter can cause damage to the boiler.

Sulfite as a treatment represents a second line of defense against oxygen corrosion. A vigorous maintenance program to safe guard against oxygen leakage into the pre-boiler system should be followed.

**Suspended Solids:** Suspended solids are the undissolved matter in water, including dirt, silt vegetation, and any other insoluble organic matter. Normally suspended solids are expressed in terms of turbidity. The presence of suspended solids in cooling water can increase impingement type corrosion. Suspended solids may also deposit in low velocity areas and create differential aeration cells. Pitting can result. The most common cause of high suspended solids is high hardness feedwater. Of the agents which cause foaming, suspended solids probably have the least effect. Reasons for the increased hardness or other suspended solids should be determined.

In line filters, or various types of pretreatment can be used to lower the suspended solids level. Various polymers assist in holding solids in suspension.

**Alkalinity:** Alkalinity is the capacity of a water to neutralize acids. Common water alkalinities consist of bicarbonate, carbonates, hydroxide, phosphate, and silicate. These alkalinities, especially bicarbonates and carbonates, break down to form carbon dioxide in steam, which is a major factor in the corrosion on condensate lines. High alkalinity also causes foaming and carry over in boilers.

Both foaming and carry over cause erratic boiler operation. When foaming occurs an anti-foam should be added or increased. The reason for the high alkalinity should be determined. It may result from lack of sufficient blow off. Pretreated makeup water and condensate should also be checked. Quite often the source of alkalinity is an overdose of alkaline internal water treatment chemical.

# Description/Instructions

---

**pH:** pH is a measure of the degree of acid or base of solution. Normal pH ranges of 6.5-9.0 will have little influence on the corrosion rate of cooling waters. If for some reason, pollution, etc., the pH is lowered into the acid range, increased corrosion can be expected. The solution lies in determining the cause of the low pH and correcting that condition. A low pH can result in corrosion of metals, while a high pH can result in scale formation.

In order to control boilers and equipment used for the external treatment of make up water, it is essential that reliable pH measurements be made.

**Phosphates:** Ground or surface waters seldom contain large amounts of phosphates. If present, it generally indicates fertilizer runoff or pollution. Phosphate from raw water can be the cause of scale problems in open recirculating cooling water systems after the water is concentrated.

**Chlorides:** Chlorides are involved in most cooling water corrosion cells. Other factors being equal, it can be assumed the higher the chloride content, the more corrosive the water. When pits or cracks occur on stainless steel or other metals, chlorides are always suspect.

High chloride levels can cause severe corrosion. Corrosion from chlorides can be controlled by increasing the amount of corrosion inhibitor or changing to a more effective inhibitor.

**Oil:** Oil is not a natural constituent of boiler water; still it can frequently enter a system through leaks in a condenser or other heat exchanger. Oil can also enter a system through the lubrication of steam driven reciprocating equipment. Whatever the source, the presence of oil in boiler water is undesirable. Oil can act as a binder to form scale. In high heat-transfer areas oil can carbonize and further contribute to the formation of scale.

Foaming is one indication of oil in boiler water. Its presence can also be confirmed by first shaking a bottle containing boiler water. If oil is present foam will result. To ensure the foaming is being caused by oil, add a small amount of powdered activated carbon to the bottle containing the boiler water and shake. Little or no foam will appear if the foaming is caused by oil.

Often oil in boiler water will originate in the condensate. This contaminated condensate should be directed to the sewer until the source of the oil is determined and corrective steps taken.

**Silica:** Silica in boiler deposits is usually combined with other constituents. Silicates form a number of different scale complexes with calcium, magnesium, aluminum, sodium, and iron. Since there is at present no effective dispersant for silicate deposits, the scale problem can be alleviated by maintaining close control of calcium, aluminum, and iron as well as silica.

**Iron (oxides):** Iron in any of its oxide or complex forms is undesirable in boiler water. It is very difficult to disperse so that it can be removed the bottom blow off lines.

Iron in its various forms can originate in the raw water makeup, condensate return water, or form directly in the boiler as a result of corrosion. Most iron oxide originates outside the boiler. It does not concentrate in the boiler and it tends to collect in stagnant areas. If a boiler is using raw water makeup, iron is almost certain to be a major component of developing scale.

**Water Hardness:** Water hardness is the measure of calcium and magnesium content as calcium carbonate equivalents. Water hardness is a primary source of scale in boiler equipment.

**Feedwater:** Feedwater is the combination of fresh makeup and returning condensate that is pumped to the boiler.

**Condensate:** Condensate is condensed steam that is normally low in dissolved solids. Hence, it does not contribute to the dissolved solid content of the feedwater. In addition, condensate is very expensive to waste. It's been chemically treated, heated, pumped, converted to steam, and condensed. This costs money and when condensate is returned to the boiler, money is saved.

# Description/Instructions

## Electrical Requirements

a) Connect wiring as shown in the wiring diagram which is furnished inside the electrical control panel box.

b) Be sure to install a separate fused disconnect for each. The disconnects should be installed in compliance with the NEC (National Electric Code) and all local codes.

c) Connections for an optional audible alarm are provided in the control panel and are clearly indicated on the diagram.

## Fresh Air Supply for Boiler

a) It is most important to provide free access of air to the boiler. To burn fuel properly, it requires one square inch opening of fresh air for every 3,000 BTU input of fuel. (6.4cm<sup>2</sup> for every 756 Kcal).

b) Proper ventilation of the boiler room is essential for good combustion. **Install two fresh air openings**, one at a low level (24"–610mm from floor) and one at a higher level in the boiler room wall. This will provide a flow of air to exhaust the hot air from the boiler room. **Room temperature not to exceed 100°F.**

c) The following openings are recommended for each size boiler:

ICS Boiler Make Up Air Opening				
HP	CFH Input	BTU Input	Opening Size (Ft. <sup>2</sup> )	Opening Size (M <sup>2</sup> )
4	168	168,000	0.58	0.05
6	242	242,000	0.84	0.08
10	404	404,000	1.40	0.13
15	606	606,000	2.10	0.20
20	807	807,000	2.80	0.26
25	1,046	1,046,000	3.63	0.34
30	1,211	1,211,000	4.20	0.39
50	2,093	2,093,000	7.27	0.68
60	2,511	2,511,000	8.72	0.81

**Be sure total BHP = proper make up air opening size. For instance if you have three 10 BHP boilers, it is a total BHP of 30, and the 30 BHP make up air opening size is recommended.**

These measurements are subject to state and local regulations. The installation of exhaust fans in a boiler room is not recommended. An exhaust fan, or similar equipment can create down draft in the stack or restrict the burner's air supply which will result in poor combustion. It is essential that only fresh air is allowed to enter the combustion air system. Foreign substances, such as combustible volatiles and lint, in the combustion system can create hazardous conditions.

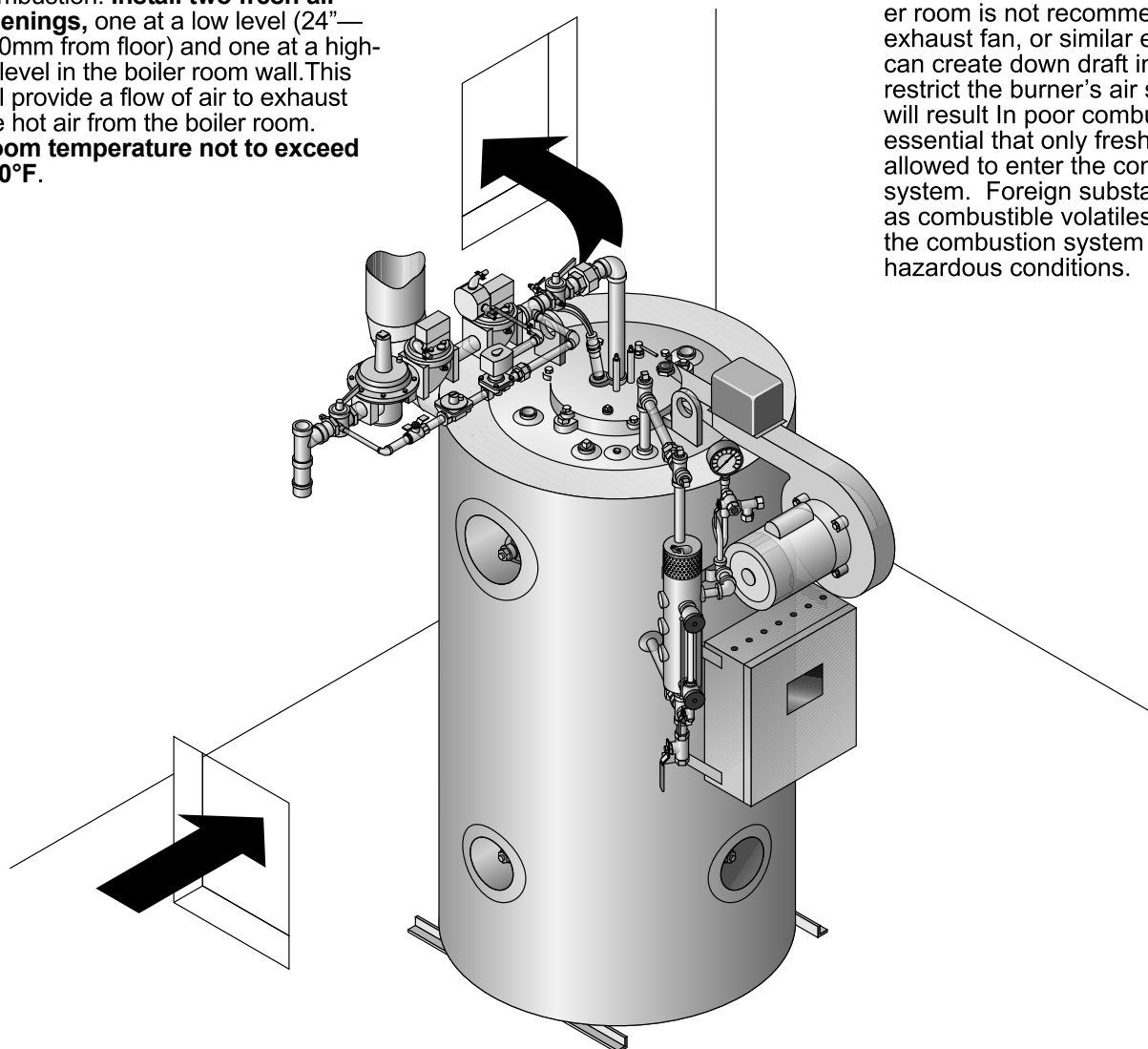

# Description/Instructions

## Conventional Venting

**a)** The stack should rise continuously to the connection with the chimney, and should contain no more than two bends at 45 angles or less. If required as the result of space limitations, one 90 elbow can be fitted at the back of the boiler. There should be two feet of straight, horizontal flue before any bends or turns. Any alternative stack arrangement must supply a negative .02 to .04" W.C. pressure (0.508 to 1.016 mm) with the burner off.

**b)** The run in the total distance of stack ducting, as measured in a straight line from the outlet of the boiler to the outlet of the stack, should not exceed 25% of the rise. With the exception of a duct run described in Item a, horizontal sections of ducting must be avoided, and should not exceed four feet of total run.

**c)** The stack and chimney material shall comply with all local codes.

**d)** Adequate provision must be made for the support of the weight of the chimney and stack to avoid having too great a load imparted to the flue outlet connection of the boiler.

**e)** The proper flue size and draft control is most important for proper burner operation. The flue must be as large or larger than the outlet on the boiler. Avoid flue piping and elbows by placing the boiler as close as possible to the chimney.

**f)** A mechanical draft regulator should be installed in the flue outlet. Do not install the draft regulator prior to the first turn of the flue.

BHP	Boiler Flue Size	
	Inches	Millimeters
6	6	152
9.5	6	152
10	6	152
15	8	203
20	10	254
30	12	305
40	12	305
50	12	305
60	12	305
4	6	152

**g)** The installer should check the draft with a meter at negative .02 to .04" W.C. pressure (0.508 to 1.016 mm) with the burner off.

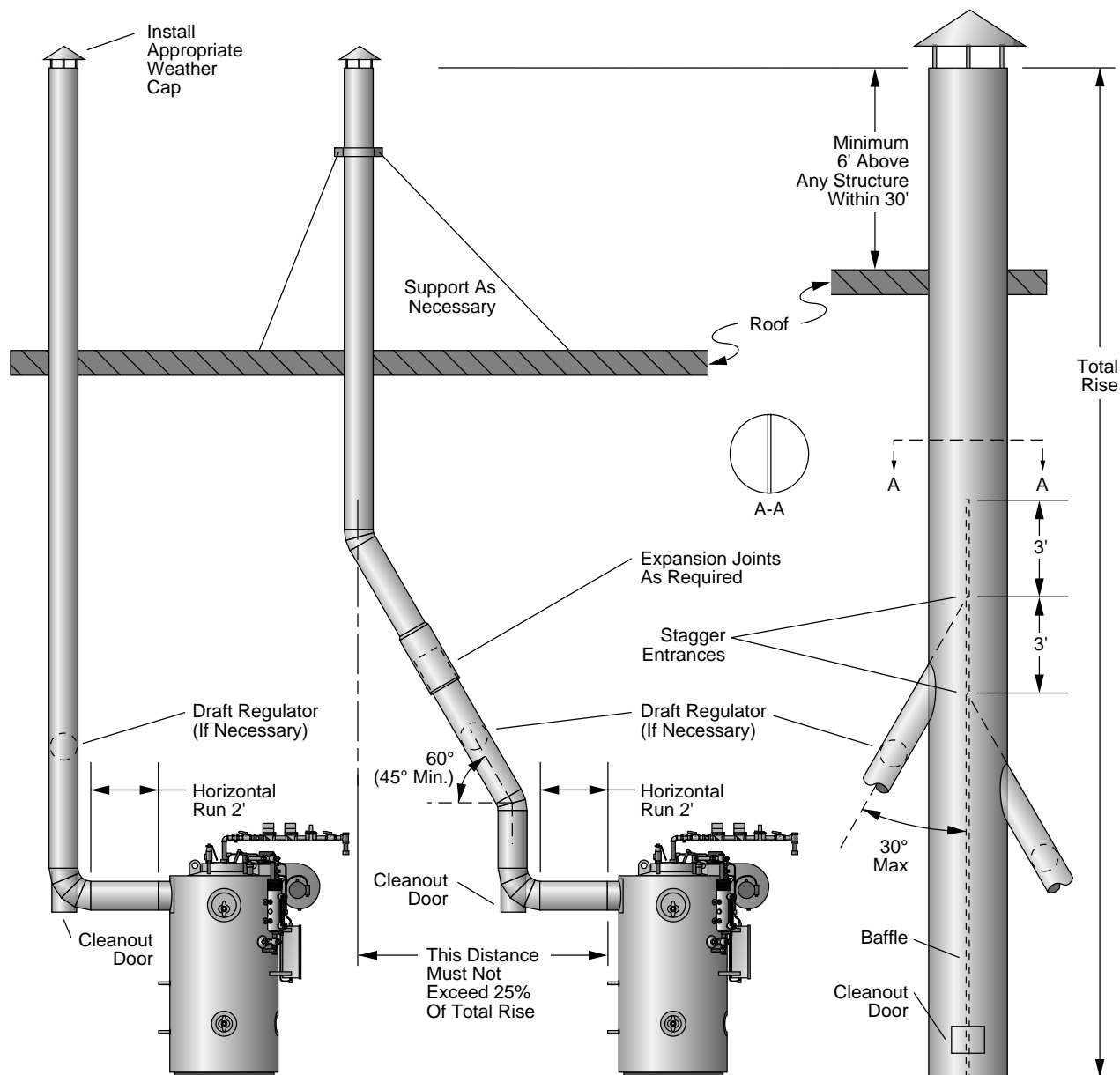

# Description/Instructions

## Exhaust Side Wall Venting (UL and MEA Approved- MEA File Number 68-79-E Vol. 2 )

a) Boilers for which sidewall venting may be utilized are No. 2 oil, natural gas, or combination No. 2 oil and natural gas, sizes 4 to 30 H.P. The following criteria is required for installations using sidewall venting:

- 1) Flue vent piping shall be pitched upward at 1/4" per foot of length.
- 2) A U.L. Approved draft fan must be installed to provide sufficient draft (-.02 to -.04 inches WC pressure - 0.508 to -1.016 mm) to safely vent the products of combustion.
- 3) The draft fan should be located as close to the flue outlet as possible.
- 4) Draft regulation sufficient to lower the draft to between -.02 and -.04 inch WC pressure (-.508 to -1.016mm) may be required. The draft regulator(s) must be between the boiler and draft fan.
- 5) The draft fan shall have an air flow proving switch wired in series with the boiler air safety switch.
- 6) The sidewall vent total length from boiler exhaust to termination shall not exceed 35 feet (10.7 m) with 4 elbows maximum.

## Combustion Air Intake (UL and MEA Approved- MEA File Number 68-74-E Vol. 3 )

a) Vertical boilers as described in MEA 68-79-E Vol. 3 applied with combustion air intake assembly. This shall be applicable only to gas fired units, sizes 4-30 boiler horsepower. The following criteria is required for installations using combustion air intake assemblies.

- 1) Outside air intake inlet shall be equipped with a vent cap in order to prevent flame blow out from excessive wind. This vent cap shall have a minimum cross sectional opening equal to an 8 inch vent pipe.
- 2) All intake ducting shall have a cross sectional area equal to or greater than 50 square inches.
- 3) A mesh screen shall be affixed to the air inlet with openings of approximately 1/2" x 3/4".
- 4) The total length from outdoors to the boiler intake shall not exceed 35 feet (10.7 m) with four elbows maximum.

## Corrosion of flue pipe

a) In the case of a combustion flue pipe, acid may develop over a long period of time by the following process. Chlorine containing gases, such as halocarbon refrigerants, carbon tetrachloride, trichloroethylene,

or perchloroethylene, when drawn into combustion air are broken down into elemental chlorine gas which exits up the flue pipe. If the flue pipe is cold, as it would be if the combustion process had been off for some time, the water vapor condenses in the flue pipe during the first few minutes of ignition and the chlorine in the combustion gas dissolves in the water forming hydrochloric acid. As the combustion system flue line increases in temperature, the water vapor no longer condenses because the flue temperature is above the dew point of the combustion gas.

The combustion gas then dries out (dehydrates) the hydrochloric acid solution leaving behind dry chloride salt.

b) When the next cold start-up occurs, the process repeats except that more and more chloride collects and concentrates along the flue. As the quantity of chloride increases it does not dehydrate completely as the flue heats up and a corrosive poultice develops which attacks the steel and will also attack the boiler.

c) Concentration levels of only a few ppm of chlorine containing compounds in combustion air can produce serious corrosion over long periods of time. High chlorine containing compounds such as carbon tetrachloride or perchloroethylene would be prime suspects .

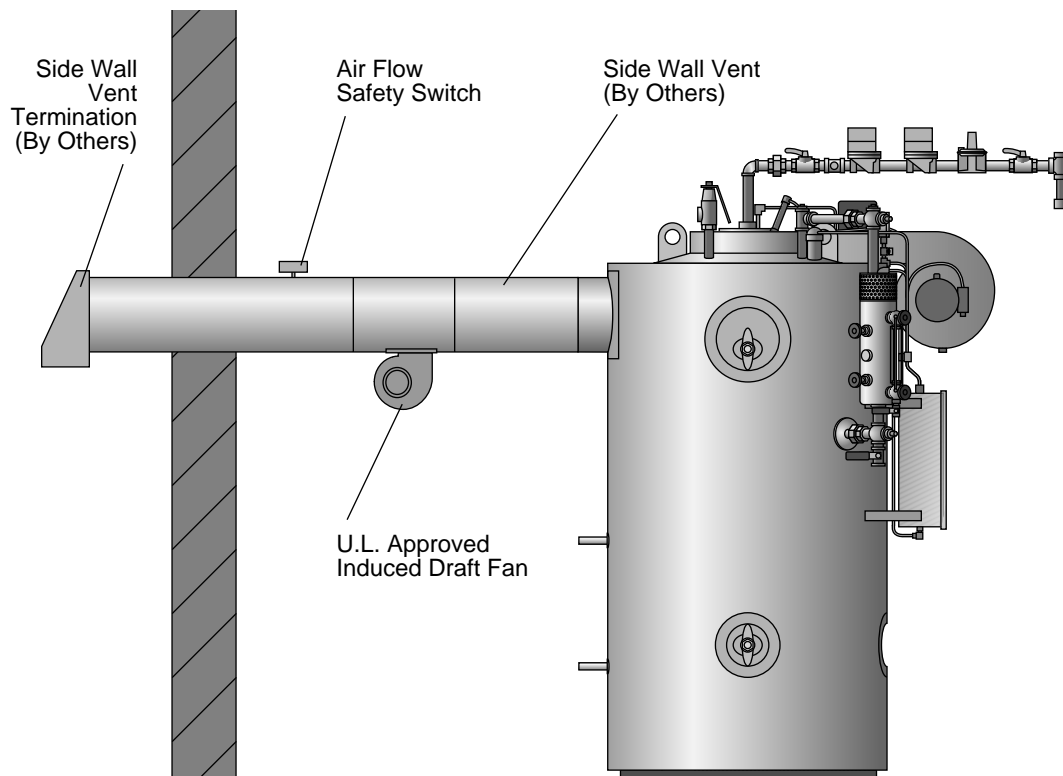

# Description/Instructions

## Installation Check Points

- 1) Make sure all piping connections are complete and tight.
- 2) Make sure the pressure controls are adjusted properly.
- 3) Make sure all electrical connections in the control panel box, the water column, and elsewhere are secure.
- 4) Make sure the door in the boiler room is closed. Combustion air contaminants can cause damage to the boiler jacket and stack.

### NOTE

After installation is complete and prior to operation the pressure vessel should be cleaned.

### Cleaning the Pressure Vessel

a) After the boiler has been installed and before it is placed in service it is advisable to purge the pressure vessel of any oil film, dirt, or other impurities. Clean the pressure vessel as follows:

- 1) Isolate the boiler from the system by shutting off the main steam valve.



- 2) Remove the steam safety valve.



- 3) Mix washing soda with water in a one-gallon container and pour it into the boiler through the steam safety valve opening.



- 4) The mixture of washing soda to water is as follows:

Boiler Size	Soda
4 - 6	1 lb. (454g)
10 - 15	2 lb (908g)
20 - 30	3 lb (1362g)
40 - 50	3-1/2 lb (1589g)
60	4 lb (1816g)

- 5) Replace the steam safety valve.

- 6) Fill the boiler with water. Water level is about center in the water gauge glass.

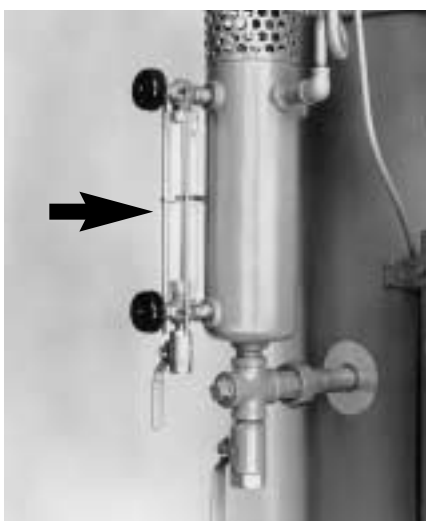

- 7) Generate 15 PSI (1.054 kg/cm<sup>2</sup>) of steam and shut off the boiler. Allow this hot solution to remain in the boiler for 10 minutes.



- 8) Drain and flush the boiler twice with fresh water.

- 9) To remove all the oil and dirt from the main steam and the condensate return lines, allow the returns to go into a floor drain or a safe discharge point for the first week of operation.

### CAUTION

**Do not store halogenated hydrocarbons near or in the boiler room.**

In general, ensure that the boiler area is in conformance with established boiler room requirements. Review national and local codes.

As a final checkpoint, again,

### Water Treatment

**We cannot emphasize enough the importance of proper water treatment: Water analysis should be made by a competent water treatment concern and their recommendations should be followed.**



# 3



# Operation

## Starting the Gas Fired Boiler

**Stop! Make sure you have read and followed all previous safety information.**

Check with local authorities where approval for start-up is required. In some localities, final inspection of services may be required.

In general, ensure that the boiler area is in conformance with established boiler room requirements. Review national and local codes.

Carry out the following procedure on the initial start up of the boiler and on every subsequent occasion when restarting the boiler after a shut down.

- 1) Close the blow-off valve.



- 2) Close the water gauge drain valve.



- 3) Open main steam stop valve at the top of the boiler.



- 4) Open the water feed valve on the boiler.



- 5) Open valves on makeup water line to return if return system is used.

- 6) Place feedwater pump fused switch in the "on" position.



## NOTE

a) The fused disconnect switch that controls the feed water pump should be kept in the "on" position at all times during the boiler operation as well as during the non-operating period of the boiler.

b) This switch should be turned "off" only when repairs or adjustments should be made.

## NOTE

The pump will continue to operate until the water reaches the correct level in the boiler. This level is approximately the center of the water gauge glass.

7) Activate the boiler power on switch, located on the side of the panel box.

8) With the unit full of water the low water safety relay(s) will be in a lock-out mode. Press the low water safety relay manual reset button located on the side of the control panel box.



# Operation

## Gas Burner Set Up

**NOTE: Refer to Section LE for LOW EMISSIONS BURNERS**

- a) Open the manual gas cocks on the pilot and main lines of the gas head.
- b) Switch on the main power to the burner. The water level relay is equipped with a manual reset. Depress the button on the box.
- c) The flame programmer is the main control in the panel box. The programmer in conjunction with a sensing device, either a flame rod or a UV scanner, "supervises" the ignition sequence - proves the flame is satisfactory, and finally "monitors" the established flame. Should any fault occur, either during the ignition sequence or during normal running, the programmer will immediately go to "lock-out" and the burner will shut down.

- d) When the pilot flame is established, the flame rod (or ultra-violet scanner) senses the voltage which is created in the flame between the flame rod and the gas nozzle (ground). This signal is transmitted back to the flame programmer which opens the main gas valve giving a main flame.

- e) Fulton 4 - 30 h.p. natural gas fired boilers can be equipped with flame rods or UV scanners.

- f) All Fulton propane or butane boilers and 50 and 60 HP Fulton natural gas boilers are standardly furnished with UV Scanners.

- 1) If the installation is new or the burner has been disassembled, the burner may not fire at the first attempt due to air which must be purged from the gas lines. This will result in the burner flame programmer going to lockout. Repeat the procedure for starting the burner.

- 2) The main gas valve will remain open as long as there is a demand for heat and the flame is carrying a sufficient signal to the flame programmer.

- 3) If the flame is not established at the start, the safety switch in the flame programmer control will open the contacts and shut off the burner.

- 4) Push the reset button on the control to reset. If trouble persists, it may be necessary to check the flame rod setting or the UV scanner. See Maintenance Section 4 for procedure to check flame rod setting or UV Scanner.

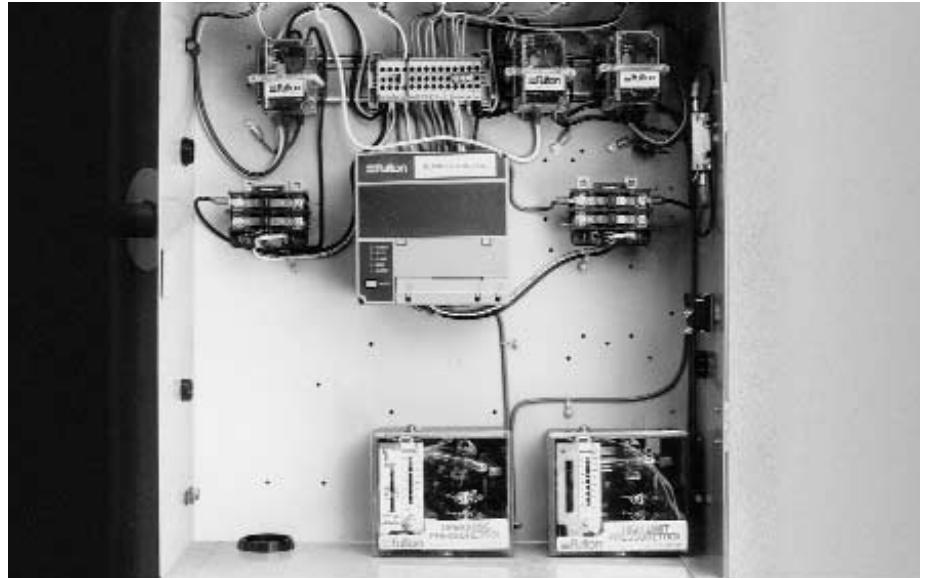

4-50 HP – 7895 flame safeguard control



60 HP – 7800 flame safeguard control



4-30 HP with flame rods



50 and 60 HP with UV Scanner

# Operation

## Gas Burner Set Up For Boilers Equipped with Modulation

- a) Modulation is available as an option on Fulton gas fired steam boilers for 30 -100 HP units only.
- b) Boilers equipped with modulation will have the linkage rod disconnected between the modulation motor and the gas butterfly valve for shipment.

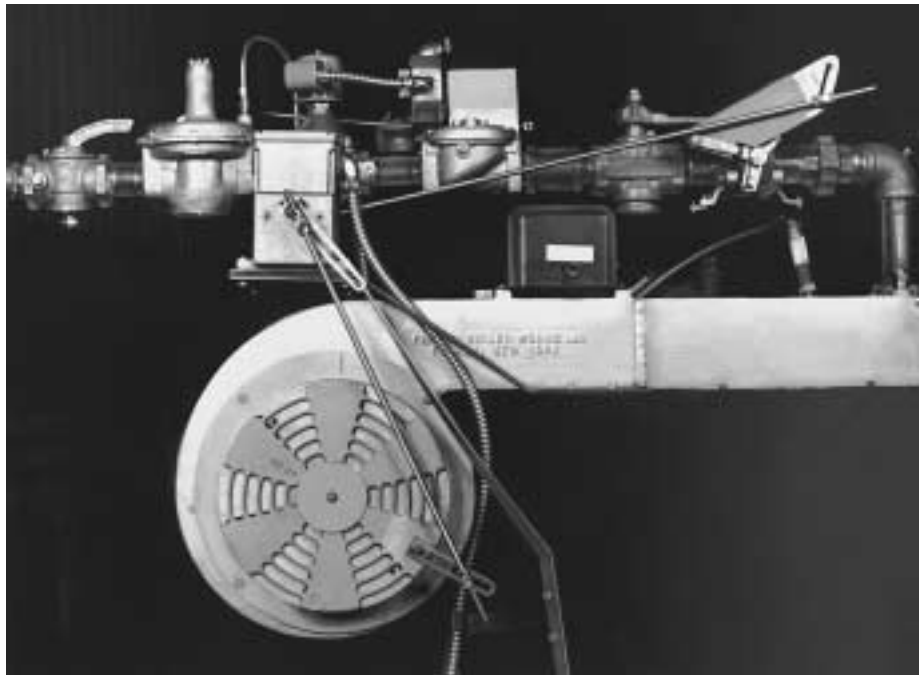
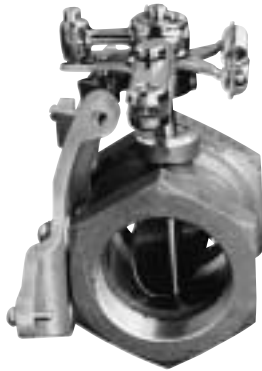

**Modulating Gas Fired Burner**

- c) Mount the gas train on the pipe nipple of the burner plate with the gas train inlet directly facing over the panel box. Reconnect the linkage from the butterfly valve to the modulation motor.

- d) The end of the linkage arm that attaches to the butterfly valve will have a notch on both sides of it, where the swivel collar should be centered. This setting was based on factory test fire conditions.

- e) Combustion analysis should be done at the installation to make any changes to insure proper combustion characteristics.

- f) The modulating burner will have a modulation lock switch in the panel box to enable you to lock the firing sequence anywhere along the firing rate from low to high.

- g) Depending on the combustion characteristics, it may be necessary to adjust both linkage arms. To adjust the linkages, unscrew the swivel collar and move the linkage rod in the appropriate direction.

- h) Modulating burners will have a proportioning pressure control in addition to the standard operating pressure control that will send a 0-135 ohm signal to the modulation motor to adjust the firing rate. Both pressure controls should have the same setting.

- i) NEMA 4 units will use a digital pressure controller with transducer as the operating pressure control which sends a 4-20 ma signal to the modulation motor to control firing rate.

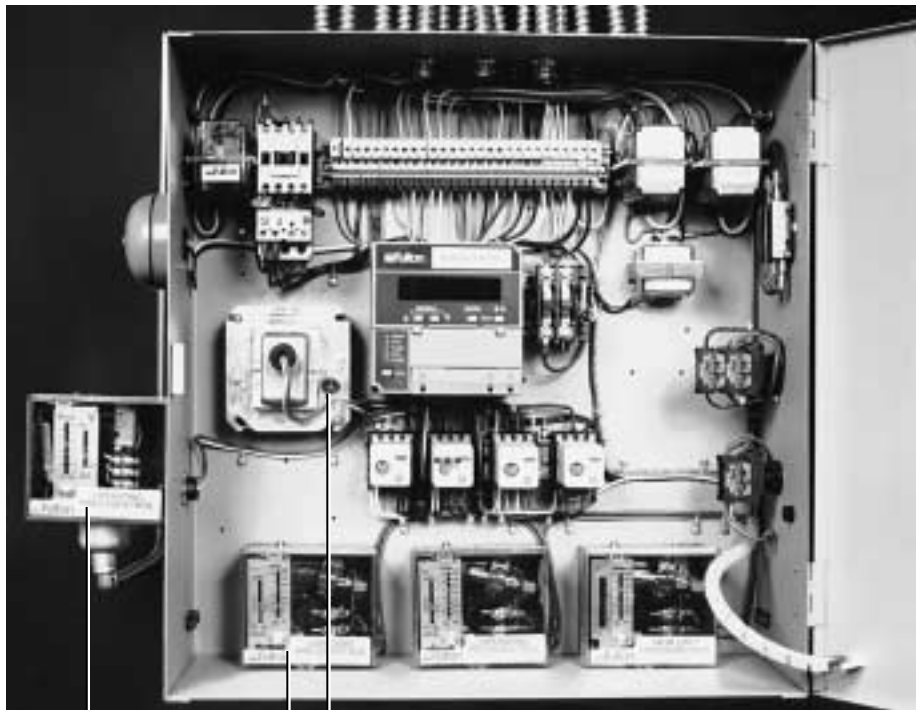

Modulation Hold/Lock Switch

Night Heating Pressure Control (Optional)

Proportioning Pressure Control

**Panel Box for Modulating Gas Fired Boilers**

# Operation

## Gas Burner Set Up For Boilers Equipped with High-Low-Off

- a) A gas fired burner equipped for high-low-off firing is available as an option on Fulton gas fired steam boilers for 30 -100 HP units only.
- b) Boilers that have a high-low-off firing rate will have a linkage between the high-low gas valve and the primary air gate. This valve is equipped with a spring return.
- c) The linkage will be disconnected from the gas valve for shipment.
- d) Mount the gas train on the pipe nipple of the burner plate with the gas train inlet directly facing over the panel box. Reconnect the linkage from the primary air gate to the high-low gas valve.
- e) The end of the linkage arm that goes to the gas valve will have a notch on both sides of where the swivel collar should be centered. This setting was based on factory test fire conditions.
- f) Combustion analysis should be done at the installation to make any changes to insure proper combustion characteristics.
- g) To adjust the linkage, unscrew the swivel collar and move the linkage rod in the appropriate direction. The high-low-off configuration comes with two operating pressure controls.
- h) Set the low operating pressure control to approximately 60% of your desired set point and the main operating pressure control to your desired set point.

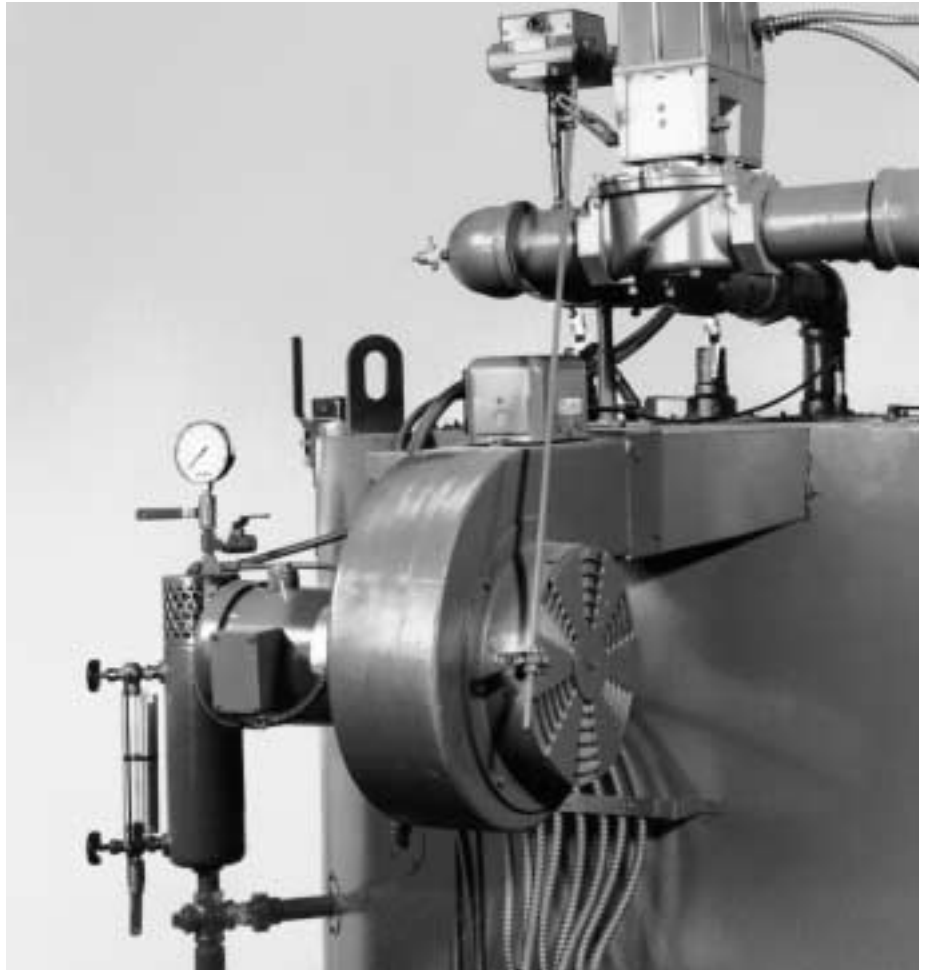

Gas burner equipped with high-low-off firing

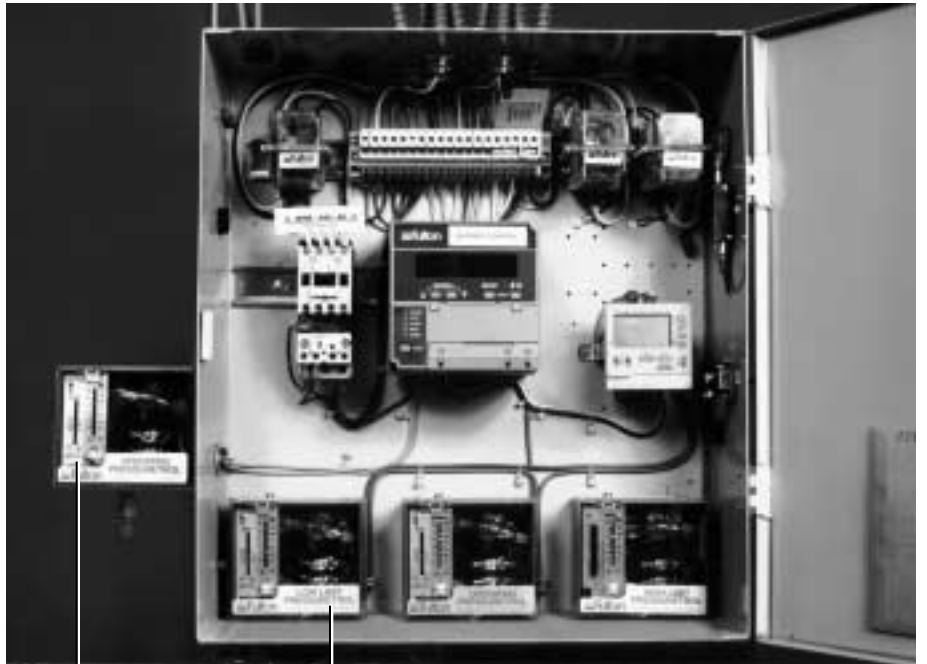

Night Heating Pressure Control (Optional)

Low fire Pressure Control

Panel Box for Boilers equipped with high-low-off firing

# Operation

## WARNING

Prior to the commencement of any work requiring the removal of cover plates and the opening of the control panel box, the electrical supply to the boiler must be disconnected.

### Primary Air Adjustment for Fulton Gas Fired Steam Boilers

a) The primary air adjustment or main air control is located at the fan housing face. This control is used to supply the burner with excess air needed to facilitate good combustion. Too much or too little air will result in poor combustion. It is important to make sure the lowest level of excess oxygen is present while still maintaining a high level of carbon dioxide and negligible carbon monoxide. Using a CO<sub>2</sub> or O<sub>2</sub> tester it is possible to determine the percent of excess air in the combustion mixture.

b) It is a good policy on a gas fired unit to have between 3.5% and 4% oxygen present in the combustion. This will give you 10.5% to 9.5% carbon dioxide. The carbon monoxide level should always be less than 400 PPM.

### Secondary Air Adjustment Procedure for Fulton Gas Fired Steam Boilers

a) The secondary air control adjustment is located on the top, right-hand side of the burner assembly. This damper type air controller is used to introduce air to and through the blast tube of the burner. The purpose of the secondary air adjustment is to proportionately divide the air to the center or outer fire chamber. By moving the damper closed, the air is forced to the outside of the fire chamber with less air going down the the



Secondary Air Adjustment 4-30 HP



Primary Air Adjustment is located at the fan housing face



Secondary Air Adjustment 40-60 HP

blast tube area. By pulling the damper open more air is forced down the blast tube and less on the outside wall of the deflector face and fire chamber.

b) It is important in the combustion process to maintain proper air mixtures between the outer surface and center of the blast tube area. On most boilers the damper is locked in a wide open position. However, if it is necessary to close the damper, care should be taken to close the damper slowly and no more than 1/4 of the distance of the swing of the damper assembly.

c) A visual examination down the blast tube should reveal that no heat, flames or fumes are backing up through the burner plate area. If they are, the secondary damper must be opened up once again. Failure to

remove the flame or gases from the blast tube area can cause a backfire as well as cause premature failure of electrodes, flame rods, and other burner components.

d) A visual inspection down the burner view port should also show the fire completely covering the furnace walls. If the fire is tunneling down or is not to the outside wall of the furnace, the efficiency will drop off. Close the secondary air damper until tunneling stops.



Burner Viewing Port  
Blast Tube Viewing Port

# Operation

## Boiler Controls

### a) Flame safeguard burner control—

This is the main control in the panel box. The programmer in conjunction with a sensing device, either a flame rod or an ultra violet scanner, "supervises" the ignition sequence - proves the flame is satisfactory - and finally "monitors" the established flame. Should any fault occur, either during the ignition sequence or during normal running, the programmer will immediately go to "lock-out" and the burner will shut down.

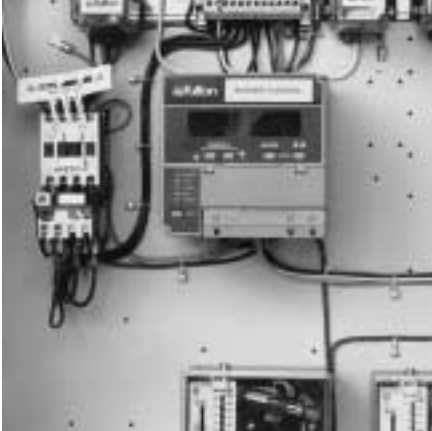

### b) Low Water Cut-Off—probe type—

Cuts off the unit when water level is too low after a 3 second time delay to avoid nuisance shut downs. As a standard feature, Fulton boilers are equipped with ASME CSD-1 Code controls which include a manual reset feature on the burner low water cut off relay and ASME CSD-1 Code controls also feature an independent second low water cut off relay. Press the low water reset button and the boiler will start.

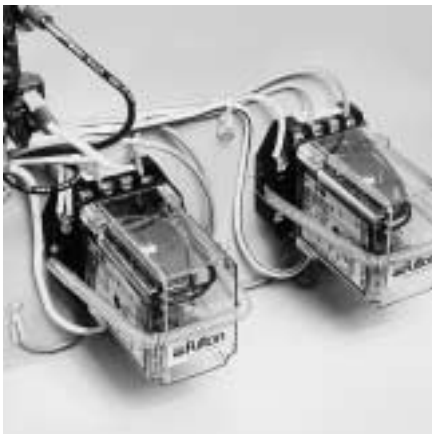

### CAUTION

Do not tamper with the safety features of the low water safety cut out.

**c) Pressure Relief Valve—** limits maximum operating pressure of the boiler.

**d) Operating Steam Pressure Control—** located in the control panel box and connected to the steam pressure gauge assembly by means of a copper tube. The pressure control regulates the on/off cycle of the burner, shutting the burner off when maximum pressure is reached and switching on when the steam pressure falls below a



predetermined level.

**e) Sight Glass Isolation Valves—** The brass sight glass isolation valves are equipped with an internal ball check. In the event that a sight glass should break, the ball will seat, preventing the discharge of steam and water. The brass valve stem must be opened fully to enable this feature. If the valve is in any other position than full open, the ball will not seat. For added safety all Fulton boilers are



equipped with gauge glass protectors.  
**f) High limit pressure control—** located in the control panel box and connected to the steam pressure gauge assembly by means of a copper tube. The pressure is usually set 10 to 15 PSI (.703 - 1.054 kg/cm<sup>2</sup>) above the operating pressure, but below the

maximum pressure of the pressure relief valve. If the pressure exceeds the high limit pressure control setting, the boiler will automatically shut off.

The high limit pressure control must be manually reset by depressing the



plunger located on top of the control.

**f) Air Pressure Switch—** mounted on the burner scroll, this switch is operated by the pressure of air entering the burner through the throat of the scroll. Absence of air, or insufficient pressure, will prevent the switch completing the circuit, thus



preventing the burner from operating.  
**WARNING**

When stopping the boiler for any extensive repairs, shut off main disconnect switches on both the boiler side as well as the feed water side.

### NOTE

To ensure that your Fulton Steam Boiler is kept operating safely and efficiently, follow the maintenance procedures set forth in Section 4 of this manual.

4



# Maintenance

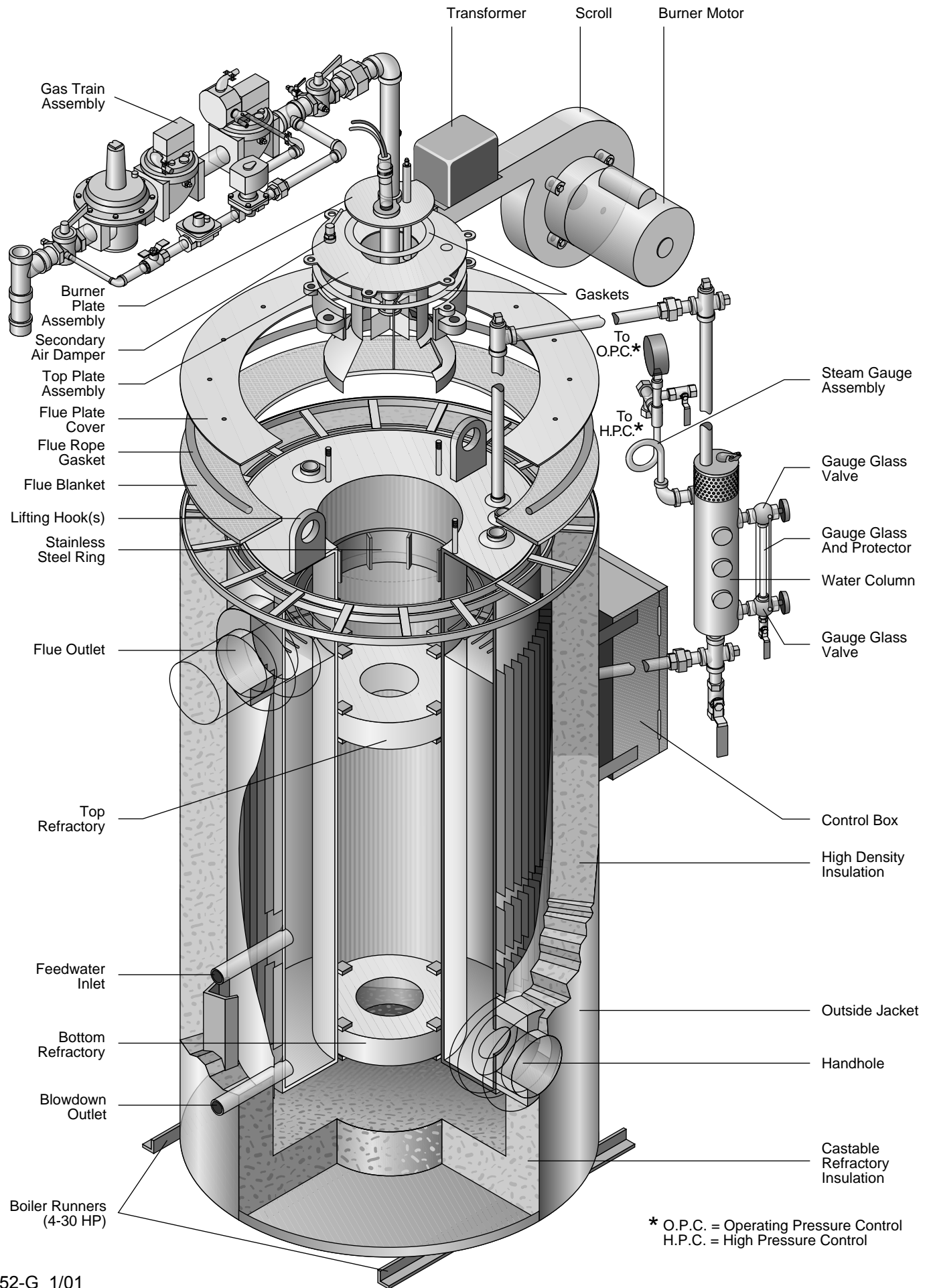

# Maintenance

## NOTE

To ensure the continued safety and efficiency of the boiler, the schedule of maintenance outlined in this section should be adhered to.

## WARNING

Prior to the commencement of any work requiring the removal of cover plates and the opening of the control panel box, the electrical supply to the boiler must be disconnected.

### Procedure for Cleaning Water Probes

Clean probe on top of boiler shell and probes in water column. Make sure there is no pressure on the boiler during the removal of the probes. Remove one probe (using a 7/8" socket), clean with very fine emory cloth and replace it before removing another to assure no probe mix-ups that would change the control functions.



For replacement purposes, installed probe lengths are indicated in the chart below. For a universally adaptable plug and probe which can be cut to length in the field to fit all boilers, order Part No. 2-20-017.

- \*A = 7-1/4" -- 184 mm
- \*B = 9-1/4" -- 235 mm
- \*C = 11-1/4" -- 286 mm
- D = 17-1/8" -- 435 mm

\*For 4 HP boilers only, water column probes are 2" shorter.

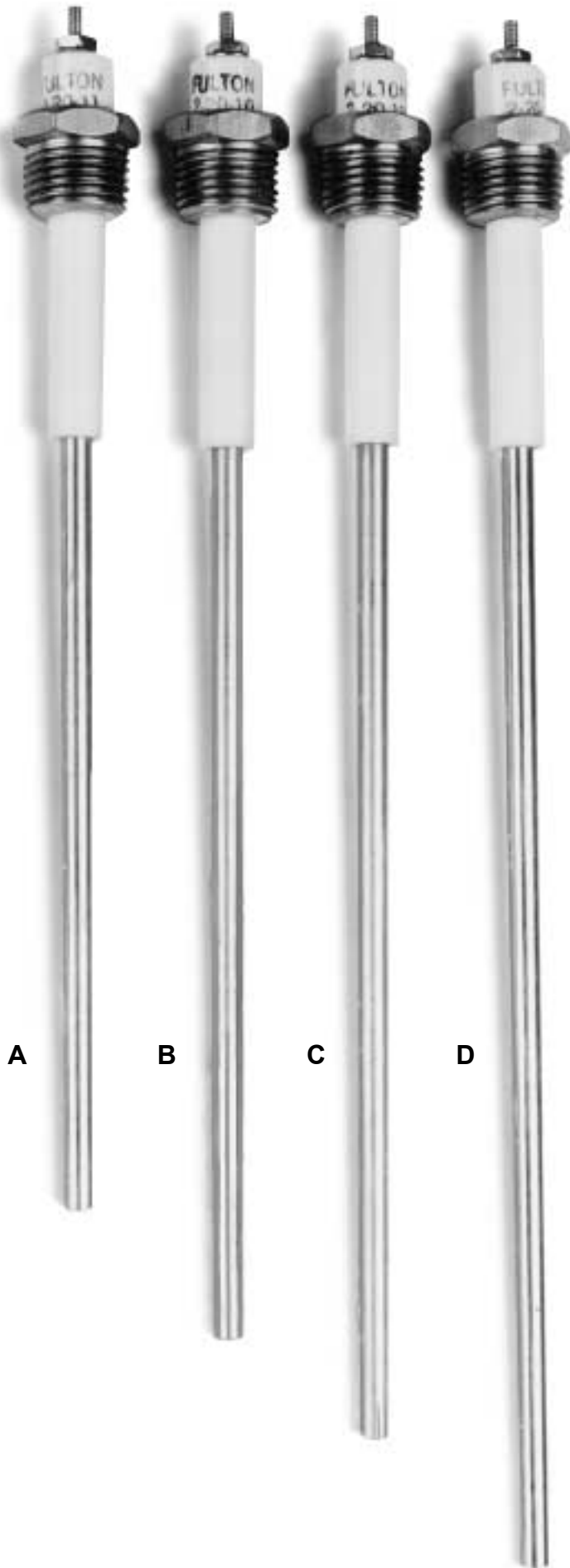

# Maintenance

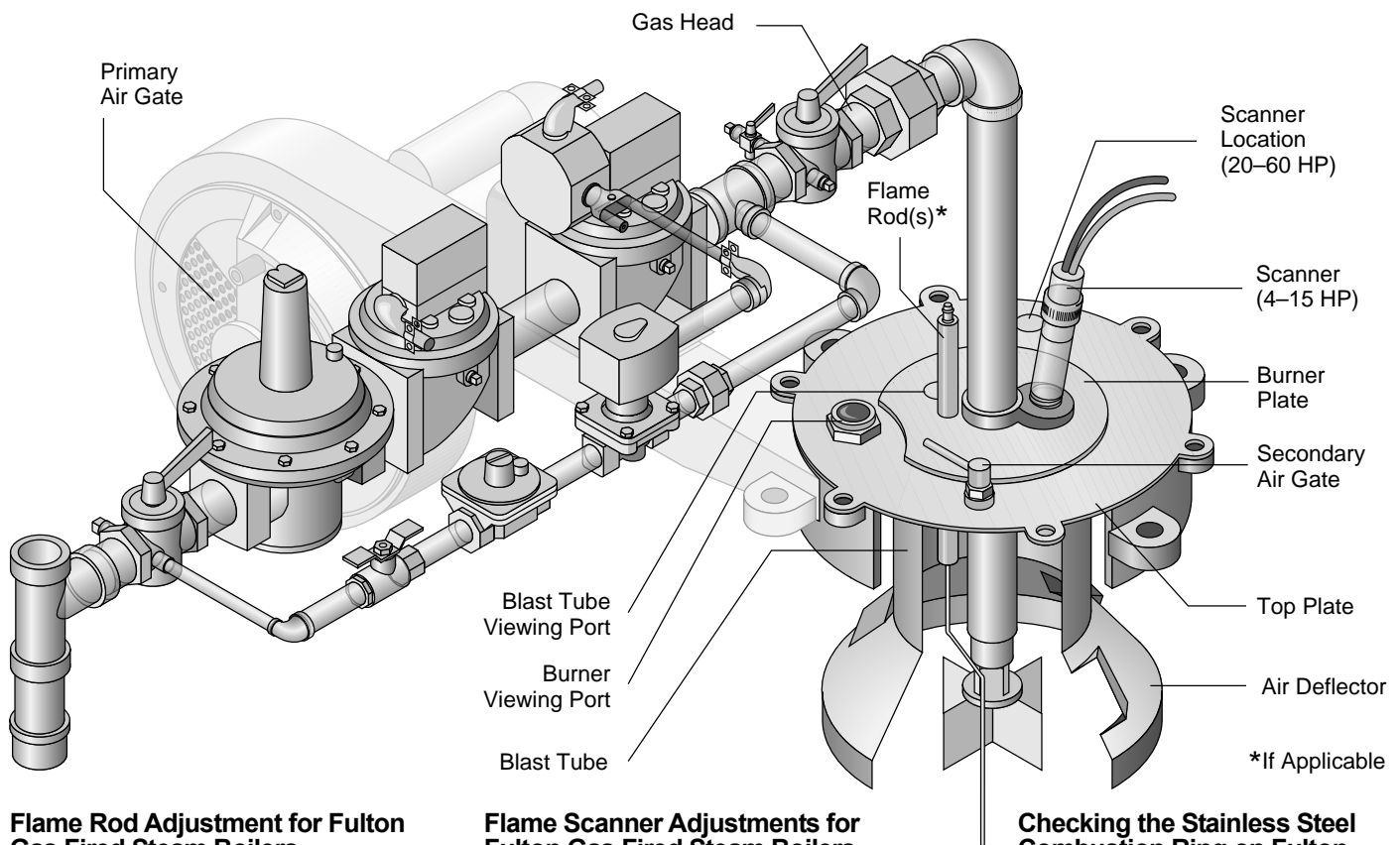

## Flame Rod Adjustment for Fulton Gas Fired Steam Boilers

**a)** The flame rod adjustment is made by loosening the lock nut and turning the porcelain portion of the flame rod clockwise or counter clockwise. Whenever a flame rod is moved, care should be taken to ensure that the flame rod does not ground out by touching the metal surface of the blast tube assembly. A keyboard display module can be used to determine proper signal response. It is necessary to establish pilot so that the main gas valve will engage. The main flame should be adjusted to an acceptable flame signal to ensure continued performance. A poor signal will result in the boiler flame programmer going off on safety.

**b)** A single flame rod is used on 4-15 HP Fulton Boilers, and two flame rods on 20 and 30 HP. If the boiler has two flame rods, adjust the flame rod in the burner plate first, with the outside one disconnected. After a good pilot signal is established on the inside flame rod, then the outside flame rod can be hooked up and the signal adjusted for proper responses.

**c)** If a signal is erratic after adjusting the flame rod, the main and secondary air supplies may need adjusting. If a flame rod is cracked or broken, the porcelain will have to be replaced to get a proper signal.

## Flame Scanner Adjustments for Fulton Gas Fired Steam Boilers

**a)** Flame scanner adjustments are made with the detectors installed and the burner running. It is essential to obtain optimum flame signal detection for safe and continual operation of the control relay.

**b)** If a scanner is inoperable, it may prove the detector is working and only an adjustment to the pilot flame is needed to improve the signal.

**c)** If the scanner is found to be defective, replace.

### NOTE:

**The scanner is located on the outside edge of the burner top plate for 20-60 HP.**

**d)** For the RM7800 Series use a keyboard display module or volt meter, the flame safeguard will require a 1.25 VDC signal to pull in the main flame. Then a maximum signal should be obtained on main flame (5.0 VDC).

**e)** Adjustments to establish a good signal may include the following items:

**1)** Primary and secondary air adjustments.

**2)** Increasing the pilot gas through the pilot gas regulator.

## Checking the Stainless Steel Combustion Ring on Fulton Gas Fired Steam Boilers

**a)** The stainless steel combustion ring in Fulton gas fired boilers (50-60 HP only) are designed to bring quick and effective flame transfer to the fire wall. The ring should fit securely and tight against the furnace wall for best results.

**b)** The ring should be inspected for distortion in the event of poor combustion which could result in flame failures.



Stainless Steel Combustion Ring

# Maintenance

## Furnace Refractory Replacement Procedure

a) Remove the burner plate and top plate assembly up and out of the scroll assembly.

b) Remove the stainless steel combustion ring from the furnace (50 and 60 HP only).

c) Remove the clean-out plugs from the bottom sides of the boiler.

4-15 HP boilers have one clean out plug located at the bottom of the boiler directly below the panel box. 20-60 HP boilers have one clean out plug located at the bottom of the boiler to the right side of the panel box. 10-30 HP Energypak Boilers have one clean out to the right of the lower right side hand hole and one clean out to the right of the rear bottom blow down.

d) Break off the top holding clips that were used to keep the refractory in position during shipping. The 4-50 HP boilers also have holding clips beneath the top refractory. There is no need to cut the holding clips located beneath the top refractory as the refractory may be rotated to avoid these clips during installation of the lower refractory. The 60- HP boiler has welded flat bars beneath the top refractory. These bars will have to be cut to change the lower refractory. Rewelding of the bars will be required prior to installation of the top refractory. For the lower refractory you will also need to break off the top holding clips that were used to keep the refractory in position during shipment.

e) Break up the top and/or bottom refractories and remove the pieces from the boiler through the clean-out plugs.

### NOTE

**If only the top refractory is to be changed, the bottom refractory need not be broken.**

f) Round and bevel the outer edges of the new refractories.

g) The bottom refractory has the largest hole, while the top refractory has the smallest.

h) Lower the bottom refractory down the furnace with wire fastened around the refractory in three positions. When the refractory is close to position, it can be tipped by maneuvering the wire to drop it flat on the holding clips. If the refractory will not tip, it may have to be removed and again rounded and beveled.

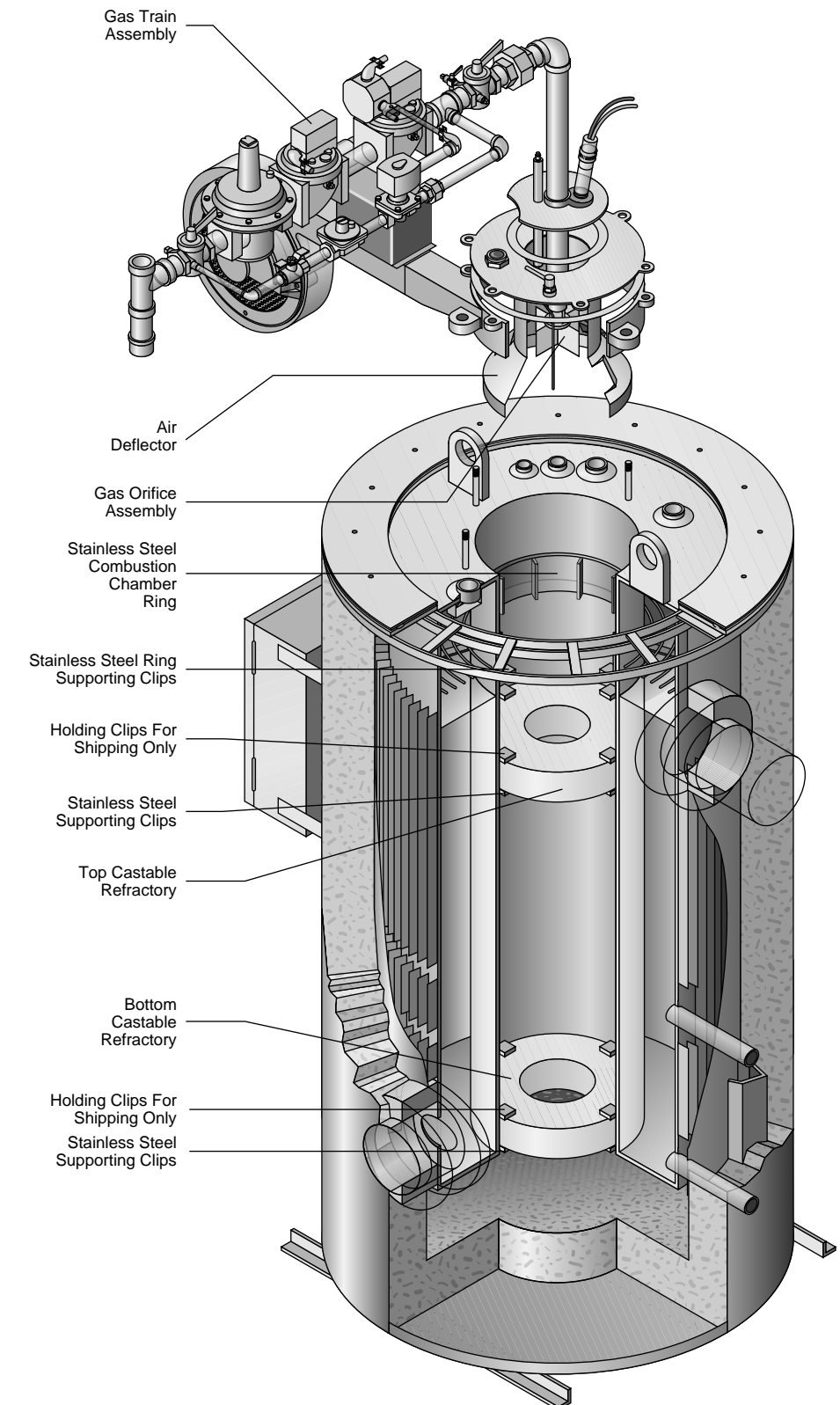

i) Install the top refractory in the same manner as the bottom refractory. When installed the outer edges must be sealed with insulcrete - a castable refractory mix available from the Fulton factory.

j) Install the stainless steel combustion ring, (50-and 60 HP only) burner assembly, and clean out plug.

k) normal operation can be resumed immediately.

It is not necessary to reinstall the shipping clips.

# Maintenance

## Recommended Daily Maintenance Schedule

a) The following procedures should be carried out daily. They are designed to prevent the build up of scale, silt, or sludge in the bottom of the boiler and in the pipes leading to the water gauge. In addition to these procedures, the advice of a water treatment supplier should be sought and followed. An ASME Section VIII blow off receptacle must be provided for the appropriate pressure.

b) Blow down the boiler each morning by starting the boiler and generating not more than 10 PSI (.703 kg/cm<sup>2</sup>) of steam. Turn on tap water to blow-off separator, then open the boiler blow off valve for approximately 10 seconds, then close the valve. Shut off tap water to blow-off separator.



**Blow Down Boiler Daily.** Shown is the blow down "Y" valve.

### NOTE

**If the boiler is being operated automatically on a time clock, the blow off operation may be done once during the working day and once at the end of the day when at 10 PSIG or less.**

c) Blow down water column each morning when boiler is at 10 PSI (.703 kg/cm<sup>2</sup>) by opening the water column and the water gauge blow off valves for approximately 5 seconds, then close the valves.



**Blow down water column each morning by opening the water column and the water gauge blow-off valves.**

d) If the feed water is being treated by compounds, make sure that this treatment is carried out carefully and according to the manufacturer's instructions.

### NOTE

**Fulton recommends that the feed-water treatment should be added between the pump and the boiler.**

e) When first starting the boiler each day, make sure ignition and burner are working properly.

f) Check water level in sight glass.

g) Check to be sure feed water pump is working.

h) For float type water level control, blow-down float chamber.

## Recommended Weekly Maintenance Schedule

a) Check that the low water cut-off relay is operating correctly in the following manner:

1) Make sure that the boiler is cool with little or no pressure showing on the steam pressure gauge.

2) With the burner operating, open the boiler blow off valve. When the water drops below the required level (note the level in the water gauge glass) the burner should shut off; this is when the water level falls below the low water electrode in the water column assembly and/or the boiler shell. Manual reset of the low water relay is required.

## Recommended Monthly Maintenance Schedule

### WARNING

**Make sure main power switch is off before starting work.**

a) Clean the water gauge glass.

### CAUTION

**Do not clean the gauge or gauge glass while pressurized or in operation.**

1) Clean the water gauge glass using a commercial non-abrasive glass cleaner. Use diluted acids such as hydrochloric (muriatic) acid when regular cleaners do not seem to work. Do not use wire brushes or any other abrasive materials which could scratch the glass. If any leakage is evident, replace the gaskets.



**Clean Glass; Replace Gaskets if Leaking**

2) Always replace the high impact plastic gauge glass protector which is standard on all Fulton Boilers.

b) Clean water pump strainers.

c) Check scanner or flame rod and ignition electrodes.

d) Check starter contacts. Burned or pitted contacts should be replaced. Do not use sand paper or file to clean.

e) Clean water traps and strainers in fuel lines.

f) Check operation of all steam traps on condensate return system.

# Maintenance

g) Remove brass pipe plug at the cross connection below water column and clean nipple into boiler. Boiler must be cold and water level below pipe.



Remove plug at cross section; clean nipple to boiler.

## Recommended Semi-Annual Maintenance Schedule

### a) Cleaning the gas burner assembly

1) Disconnect the gas head from the burner by disconnecting the union. Remove the burner plate screws. For 4-15 HP boilers with scanner, disconnect scanner from burner plate.

Withdraw the burner assembly and clean the flame rod and ignition electrode.

2) Check that the settings of the flame rod, if applicable, and ignition electrode correspond to those in the illustration below.

3) Reassemble the burner assembly and check the flame rod setting or scanner setting.

4) Check the combustion efficiency of the burner and adjust if necessary.

5) Clean probe on top of boiler shell and probes in water column. There must be no pressure on the boiler during the removal of the probes.

6) Check refractories for soot or breakage and inspect the stainless steel ring (50 and 60 HP only).

7) With the boiler under no more than 15 PSI pressure, check that the steam safety valve is operating by lifting the lever.

b) **Drain condensate tank** and clean tank by flushing with hose. Check float valve operation.

c) Check electrical controls and motors for correct operation.

d) Check water pump for correct operation.

e) Shut off the boiler completely and drain.

f) **Remove the hand holes and inspect the interior of the vessel for scale or sludge deposits.** The amount of deposits will indicate the efficiency of the water treatment being used. The frequency of the inspection will depend on the condition of the water side of the boiler.



Inspect hand holes for scale or sludge buildup.

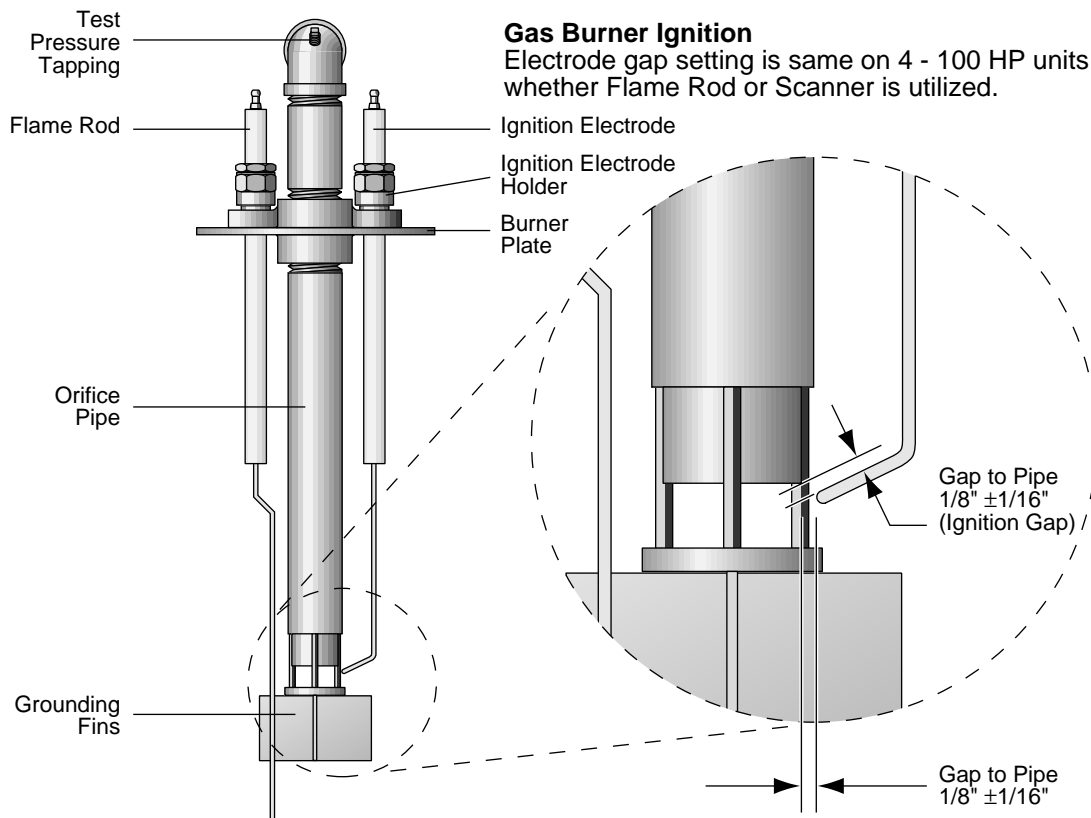



## Boiler Lay-Up Procedure

---

The following information includes suggested protocol and guidelines for boiler and ancillary equipment lay-up. When working on this equipment, it is critical to follow all product warning and caution information available in the product installation and operation manual. All content herein is subject to change without prior notice. A water treatment professional must be consulted for procedures/requirements, and actual site conditions must be factored. Guidelines below are for the vessel only. For additional information regarding the steam boilers, control panels and accessories, please contact Fulton.

### ■ Waterside Protection

The best corrosion-control program of operating boilers and ancillary equipment can be completely offset by neglect during outages, as metal surfaces are often attacked and damaged by oxygen during shut-downs. Protection can be achieved by:

1. Excluding all air from the boiler and ancillary equipment (wet lay-up).
2. Keeping the surfaces completely dry (dry lay-up).

The choice between wet and dry lay-up depends on the length of time a boiler and ancillary equipment will be out of service. Wet lay-up is recommended for short outages (30 days or less); dry lay-up is recommended for longer periods. The wet method has the advantage of permitting the boiler to be returned to service on short notice. Dry lay-up is practical only if the unit can be drained while hot.

Boilers and ancillary equipment should be drained and inspected prior to any lay-up. When time does not allow for inspection, the boiler and ancillary equipment may be stored wet without draining if the chemical treatment is injected into the boiler before it comes offline.

### ■ Dry Lay-Up

1. Secure fire equipment and close all steam stop and water feed valves.
2. Drain the boiler and ancillary equipment completely and dry all waterside surfaces by opening all handholes and manholes while the unit is still warm enough to vaporize all moisture (180 degrees F – 200 degrees F).

3. Inspect for scale and sediment deposits on waterside surfaces. Consider that a 0.1" scale deposit may increase fuel consumption as much as 16%. Cleaning should be done before final lay-up preparation.
4. Thoroughly dry internal surfaces with hot air. Fans and other air driven blowers can be used by directing them into the bottom handholes or manhole opening.
5. All areas that are not completely dry should be blown with dry compressed air. No steam or feedwater can be allowed to enter the boiler and ancillary equipment. Moisture on the waterside will cause oxygen corrosion to begin in a very short period of time and will ultimately cause serious corrosion problems.
6. Leave boiler and ancillary equipment open to atmosphere if boiler room is dry and well ventilated.
7. In damp boiler rooms or for periods exceeding the normal summer shut-down, one of three following commercial grade desiccants should be spread on water-tight wood or corrosion resistant trays.
  - Quick lime -- used at a rate of six pounds per 100 cu. ft. of boiler volume.
  - Silica gel -- used at a rate of eight pounds per 100 cu. ft. of boiler volume.
  - Activated alumina -- used at a rate of eight pounds per 100 cu. ft. of boiler volume.
8. Trays are to be placed on the top tubes of the boiler. All manholes, handholes, vents, and connections are to be blanked and tightly closed to seal the boiler and ancillary equipment.
9. Inspect every two months for evidence of active corrosion. Check the desiccant and regenerate or replace when necessary. Reseal and restore the boiler and ancillary equipment to proper conditions.

### ■ Wet Lay Up

1. Drain boiler and ancillary equipment and thoroughly inspect for sediment and scale, and clean as in points 2 through 6 above.
2. Fill boiler and ancillary equipment completely using feedwater preheated to a minimum of 208 degrees F taking care to vent all air from boiler.
3. While filling, feed in treatment chemicals recommended by a reputable water treatment firm. Levels of

approximately 300-500 parts per million (ppm) phenolphthalein (P) alkalinity and 100-150 ppm sulfite residual should be reached and maintained.

4. Fire boiler and ancillary equipment to ensure good mixing and vent boiler to purge the unit of air. All feed and blow down valves should be leak free to prevent loss of treated water or addition of untreated water. It is important to seal off and keep the unit air-tight since any air entering the boiler will promote corrosion.
5. Test the boiler water bi-monthly during the outage to ensure proper control levels are being maintained.
6. If a piece of equipment is not able to be isolated and airtight, a dry layup of that equipment may be necessary.

## ■ Fireside

Fireside lay-up procedures are designed to keep metal surfaces dry. Moisture, oxygen, and combustion residuals produce corrosion by forming acids that attack steel. Precautions taken during lay-up inhibit metal degradation and prolong boiler life.

Corrosion is a threat to a cold boiler regardless of fuel type. The common factor in all fuels is the level of impurities. While the boiler is still firing, the impurities may be thermally decomposed as they pass through the flame zone. The elements of the impurities combine into an assortment of different compounds. As the compounds stabilize, they may form either solid deposits on the tube surfaces or acidic liquids that corrode the metal.

Lay-up is a critical period for boiler maintenance and repair. It is important to clean fireside surfaces to maximize the amount of heat transfer. Consider that a 3/32" scale deposit on the fireside may increase fuel consumption by as much as 10.7%.

The deposits themselves may initiate 3) types of problems. First, as deposits form they may produce corrosion at the interface of the metal and deposit surface. Second, the deposit may trap fly-ash which adds to the bulk of the deposit surface. Third, fly-ash constituents such as iron, vanadium, and sodium may act with sulfur compounds to form highly corrosive, low ph deposits.

## ■ Fireside Protection

1. When boiler is cool, thoroughly clean tubes and other fireside heating surfaces and scrape down to the bare metal. A metal surface below 300 degrees F with 10 ppm SO<sub>3</sub> present will be cool enough to cause condensation of sulfuric acid, opening the door to corrosion. Iron or vanadium will catalyze this reaction and intensify the corrosion.
2. Clean smoke box and other areas where soot may accumulate.
3. Swab or spray fireside with a neutral mineral oil for protection of surfaces.
4. If boiler room is damp, place trays of calcium chloride or unslaked lime in combustion chamber and replace when it becomes damp.

# Maintenance

## g) Replace hand hole gaskets using the following procedure:

- 1) Remove the hand hole assembly using a 1-1/4" tee handle wrench or 1-1/4" 1/2" drive socket wrench.



Removing hand hole assembly with a Tee Handle Wrench

- 2) Remove the old gasket and thoroughly clean the surface on the boiler and the plate.

- 3) Fit the hand hole assembly as follows:

- a) Place the gasket on the hand hole plate and ensure that it is seating correctly. **Do not use any grease, lubricant, or adhesive.**

- b) Position the plate in the boiler. Set the yoke and tighten the securing nut sufficiently enough to provide a snug fit. Verify the position of the plate in the boiler, then make it hand tight and then snug with wrench about 1/4 turn. Do not compress excessively.

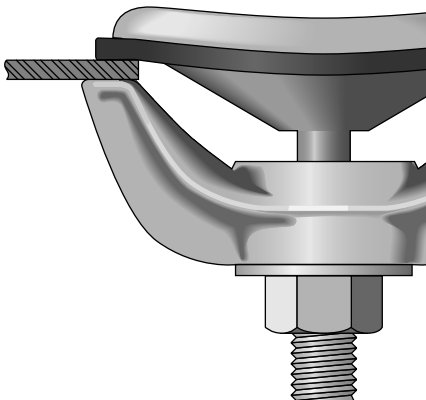

Illustration shows correct pressure on gasket.

- c) If the gasket leaks while pressure is being built up, tighten only enough to stop leakage.

Never tighten more than necessary to prevent leakage. Excessive tightening may shorten the life of the gasket.

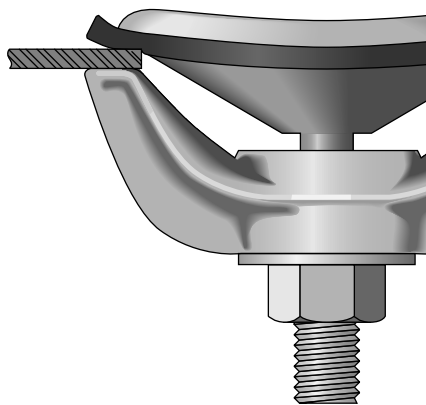

Illustration shows over compressed gasket.

- d) Refill the boiler with fresh water.

### NOTE

After a new Fulton Boiler has been in operation for several months, pieces of burned metal will be found in the space at the bottom of the boiler. These pieces of metal are the remains of a light gauge metal form which was used during manufacture for forming the boiler insulation. This is a normal condition and does not affect the efficiency or the life of the boiler in any way.

### Recommended Annual Maintenance Schedule

- a) Have combustion ( $\text{CO}_2$ ,  $\text{O}_2$ ,  $\text{CO}$ ) and input checked by responsible personnel.

- b) Dirty flues can cause air flow restrictions resulting in poor combustion and loss of efficiency.

#### Clean flues as follows:

- 1) Remove the burner and flue cover plate.



Remove burner and flue cover plate

- 2) Wire brush flue passages.



Wire brushing the flue passages.

- 3) Remove clean out plugs at lowest part of unit and clean the bottom of combustion chamber.



Removing clean out plugs.

- 4) Remove all soot from the top, and from the clean out plugs at the bottom with a vacuum cleaner.

- 5) Replace clean out plugs carefully so as not to damage insulation and replace burner and flue cover plates.

- c) Flush boiler out if necessary. See Section 2 for proper procedure for "Cleaning the Pressure Vessel."

- d) Provide annual inspection by a qualified ASME Boiler inspector.

# Maintenance

## Troubleshooting

a) The following trouble shooting guide will assist in the diagnosis and the correction of minor field problems. It contains instructions and information necessary to locate and isolate possible troubles which occur during normal operation. It

should be used in conjunction with the unit wiring diagram and the component literature provided in Section 7 of this manual.

b) The following lists cover the most common troubles that may occur on the Fulton gas fired boilers. Refer to left hand column of the chart to

locate the problem. Determine which cause, listed in the center column, that represents the problem by performing the corrective action as listed in the right hand column titled "REMEDY".

## Troubleshooting Gas-Fired Boilers

Problem	Cause	Remedy
<b>Ignition Failure</b>	1. Power Supply	Check fuse or circuit breaker. Reset or replace, as necessary.
	2. Ignition Electrodes	Check electrodes for carbon buildup and clean if necessary. Check for proper adjustment. Readjust if necessary. Check for cracks in porcelain. If found,replace.
	3. Transformer	Check voltage between transformer leads at terminal block to be sure transformer is being powered.
	4. Flame Safeguard Control	Check voltage between ignition terminal and neutral. Check must be made before control locks out on safety. If no power, replace control.
	5. Faulty Air Switch	Check for bad air switch by jumpering the two air switch leads at the terminal block. If the boiler starts and runs with these terminals jumpered, the air switch should be replaced.
	6. Gas Valve Sticking (Pilot)	Check for dirt in valve or orifice and clean if necessary. Check for faulty actuator or valve and replace if necessary.
	7. Gas Supply*	Check for gas pressure and for intermittent supply problems. Gas pressure for natural gas should be 3-1/2" W.C. plus fan pressure at the elbow to the burner and 7" to 11" W.C. at the head of the train.
	8. Loose wire connection	Check connections to all components.
<b>Flame Failure</b>	1. Power Supply	Check fuse or circuit breaker. Reset or replace, as necessary.
	2. Gas Supply*	Check for gas pressure and for intermittent supply problems. Gas pressure for natural gas should be 3-1/2" W.C. plus fan pressure at the elbow to the burner and 7" to 11" W.C. at the head of the train.
	3. Ignition Electrodes	Check electrodes for carbon buildup and clean if necessary. Check for proper adjustment. Readjust if necessary. Check for cracks in porcelain; if found, replace.
	4. Primary Air Adjustment	Check air adjustment. Air may be blowing flame away from flame rod.

\* For natural gas fired boilers. Refer to the test fire sheet for all other fuels.

# Maintenance

Problem	Cause	Remedy
<b>Flame Failure</b>	5. Flame Rod Adjustment or UV Scanner	Check flame rod for carbon buildup and clean if necessary. Check flame rod adjustment via a display module. Flame signal should be 5 VDC. Check for cracks in porcelain. If found, replace. Check for dirt on flame scanner and clean. Check for proper location of detector.
	6. Flame Safeguard Control	Check voltage at terminal leading to main gas valve. If no power, replace the control.
	7. Loose wire at fuel valve circuit	Tighten wiring connections.
	8. Contact open on air safety switch	Adjust to proper setting.
	9. Scanner wiring reversed at panel box.	Change to correct terminals.
<b>Burner Cut-Off</b>	1. Power Supply	Check fuse or circuit; reset or replace, as necessary.
	2. Gas Supply	Check to be sure main gas cock is not closed. Check coil in gas valve with OHM meter. Replace if faulty. Check gas regulator setting and readjust as necessary. Check inlet gas pressure and increase or decrease as necessary.
	3. Ignition Electrodes	Check electrodes for carbon buildup and clean if necessary. Check for proper adjustment. Readjust if necessary. Check for cracks in porcelain; if found replace.
	4. Flame Rod Adjustment or UV Scanner	Check flame rod for carbon buildup and clean if necessary. Check flame rod adjustment via a display module. Flame signal should be 5 VDC. Check for cracks in porcelain. If found, replace. Check for dirt on flame scanner and clean. Check for proper location of detector.
	5. Air Switch	Check for bad air switch by jumpering the two air switch leads at the terminal block. If the boiler starts and runs with these terminals jumpered, the air switch should be replaced.
	6. Gas Valve Sticking (Pilot)	Check for dirt in valve or orifice and clean if necessary. Check for faulty actuator or valve and replace if necessary.
	7. Weak Amplifier	Replace.
	8. Weak Pilot	Adjust to larger pilot by adjusting pilot gas pressure regulator.
	9. Faulty Liquid Level Control	Check to see if there is power to terminal number 10 when the sight glass shows the proper water level. If there is no power at this terminal, the control is bad and must be replaced.
	10. Dirty or defective UV Scanner.	Clean or replace.

# Maintenance

Problem	Cause	Remedy
<b>Poor Combustion</b>	1. Refractories	Check refractories to see if they are plugged with soot or broken in pieces. Clean or replace as necessary.
	2. S.S. Ring	Check to be sure ring is present and fits tight against the furnace wall (50-100 HP).
	3. Primary Air Adjustment	Check air adjustment. Air/fuel mixture may be off. Open primary air so fire is to outside wall of furnace.
	4. Secondary Air Adjustment	Check main air adjustment to see if it is loosened up. Adjust as necessary and tighten plate in position. Check CO <sub>2</sub> and O <sub>2</sub> levels.
	5. Draft	Check draft with a gauge. Draft should be a -.02 " to -.04" W.C. with burner off or -.04" to -.06" when operating. May need to install a barometric damper.
	6. Dirty Flue	Check flue for carbon buildup or blockage. Clean flue passages with brush.
	7. Negative Room Pressure	Make sure no exhaust fans are running in the boiler room.
<b>Burner back fires</b>	1. Refractories	Check refractories to see if they are plugged with soot or broken in pieces. Replace as necessary.
	2. Ignition Electrodes	Check electrodes for carbon buildup and clean if necessary. Check for proper adjustment. Readjust if necessary. Check for cracks in porcelain; if found replace.
	3. Flame rode adjustment or UV Scanner	Check flame rod for carbon buildup and clean if necessary. Check flame rod adjustment via a display module. Flame signal should be 5 VDC. Check for cracks in porcelain. If found, replace. Check for dirt on flame scanner and clean. Check for proper location of detector.
	5. Draft	Check draft with a gauge. Draft should be a -.02 " to -.04" W.C. with burner off or -.04" to -.06" when operating. May need to install a barometric damper.
	6. Negative Room Pressure	Make sure no exhaust fans are running in the boiler room.
	<b>Boiler will not maintain pressure</b>	1. Gas Supply
2. Dirty Flue		Check flue for carbon buildup or blockage. Clean flue passages with brush.
3. Pressuretrol		Disconnect all power to the controller. Disconnect the wires from the controller. Put an OHM meter between the switch terminals. Lower the set point of the controller. Switch should make. Raise the set point and recheck with OHM meter. Switch should break. If the controller operates improperly, replace it.

# Maintenance

<b>Problem</b>	<b>Cause</b>	<b>Remedy</b>
<b>Boiler will not maintain pressure</b>	4. Scale Built up in boiler	Refer to Section 2 "Pressure Vessel Cleaning".
	5. Refractories	Check refractories to see if they are cracked or broken in pieces. Replace as necessary.
	6. Steam traps blowing through.	Check traps to see if they are clean or replace as necessary.
	7. Boiler size.	Boiler may be undersized.
<b>Boiler is Surging</b>	1. Steam traps blowing through	Check traps to see if they are clean or replace as necessary.
	2. Perc (cleaning solvent in boiler)	Clean boiler with washing soda per instruction manual.
	3. Scale build-up or lime deposits.	Call water treatment professional and consult factory.
	4. Too much compound in system (water treatment)	Dump return tank and flush system. Have water tested by water treatment company.
	5. Too much water softener (high PH)	Have water tested by water treatment company.
	6. Too much of a load	Check total equipment horsepower required against horsepower of boiler being used. Decrease amount of equipment being used at one time.
	7. Boiler new (not cleaned).	Clean per instructions in instruction manual.
<b>Boiler Rumbles and Pulsates</b>	1. Draft problem	Check draft with a gauge. Draft should be a -.02 " to -.04" W.C. with burner off or -.04" to -.06" W.C. when operating. May need to install a barometric damper.
	2. Too much primary air	(See primary air adjustment)
<b>Boiler pushing water with the steam</b>	1. Steam Traps	Check traps. Clean or replace as necessary.
	2. Too much boiler compound	Dump return tank and flush system . Have water tested by water treatment company.
<b>Pump will not cut off</b>	1. Dirty Probes	Clean or replace as necessary.
	2. Relay failed	Make sure relay is plugged in tightly. If so, replace water level relay.
	3. Ground Connection	Check for tightness and clean.

# Maintenance

<b>Problem</b>	<b>Cause</b>	<b>Remedy</b>
<b>Pump runs but does not put water into boiler</b>	1. Vapor locking of pump.	Allow system to cool down, check steam traps and check to be sure return lines are not insulated. Check return tank temp. If it is above 180 deg. F, (82 deg. C) vapor locking of pump will occur. Inspect check valves. Clean and replace as needed. Replace pump with multistage centrifugal good for 250 degrees F (121 deg.C).
	2. Impeller Adjustment	Check for impeller wear and adjust per component information in instruction manual (Burks only).
	3. Back pressure on pump	Need to install repair kit on pump.
	4. Plugged feed water nipple	Check and clean or replace as necessary.
<b>Water pump will not come on at times.</b>	1. Scale on probes.	Check and clean or replace as necessary.
	2. Bad Pump Contactor	Check to see if contactor is being powered. Check to see if contactor coil is pulling in. Replace if necessary.
	3. Bad Pump Motor	Check the incoming power to the pump to be sure it is receiving power. If power is present but motor does not run, replace it.
<b>Low Fuel pressure</b>	1. Gas pressure regulator	Check and replace.
<b>Boiler Flooding</b>	1. Pump does not shut off	Dirty Probes. Clean or replace as necessary.
	2. Relay failed	Make sure relay is plugged in tightly. If so, replace water level relay.
	3. Ground Connection	Check for tightness and clean.
	4. Vacuum created with boiler off.	As the boiler cools off, it pulls water from the system piping. To prevent this, add a 1/4" check valve on the steam gauge assembly piping, which closes under pressure and opens under vacuum.

# 5

## **ICS (FB-A) Classic & ICX (FB-F) Edge manual update:**

For all new ICS (FB-A) Classic boilers manufactured 2018 and after, the following updates have occurred:

The ICX (FB-F) Edge model boiler has been discontinued.

The ICS (FB-A) Classic is now configured as follows:

- The ICS (FB-A) Classic boilers initially configured as natural gas or propane boilers are configured with the ICX (FB-F) Edge second flue gas pass rib heat transfer pattern and cannot be converted to fire #2 oil. These boilers will also require use of the Edge cleanout brush in lieu of the standard. The Edge cleanout brush part number is 2-60-000155.
- The ICS (FB-A) Classic boilers initially configured as #2 oil boilers or combination natural gas/propane and #2 oil boilers are configured with the further spaced Classic second flue gas pass rib heat transfer pattern. These boilers will also require use of the Classic cleanout brush. The Classic cleanout brush part number is 2-60-000112.

# Parts

## Spare Parts

a) It is important that the correct replacement part is fitted to your Fulton Gas Fired Steam Boiler.

b) When ordering replacement or spare parts, make sure that the full information given in the Parts List is supplied, together with the following details as shown on your boiler identification plate:

1. Boiler Number
2. Boiler Type
3. Electrical Specifications

**Note:**

The policy of Fulton Boiler Works, Inc. is one of continuous improvement, and therefore, we reserve the right to change prices, specifications, and equipment without notice.



**Fulton Fuel-Fired Steam Boiler**

Boiler No. \_\_\_\_\_

National Board No. \_\_\_\_\_

Model \_\_\_\_\_ Year \_\_\_\_\_

MD Lbs Steam/Hr SH HD HS MWP

\_\_\_\_\_

**Fulton**  
Fulton Boiler Works, Inc.  
Pulaski, NY 13142

\_\_\_\_\_

The image shows a black identification plate with white text and fields. At the top, it reads 'Fulton Fuel-Fired Steam Boiler'. Below this are several rows of information: 'Boiler No.' followed by a blank line; 'National Board No.' followed by a blank line; 'Model' and 'Year' each followed by a blank line; and a row of five categories: 'MD Lbs Steam/Hr', 'SH', 'HD', 'HS', and 'MWP', each followed by a blank line. At the bottom left is the 'Fulton' logo and company name 'Fulton Boiler Works, Inc. Pulaski, NY 13142'. At the bottom right is a large blank rectangular area.

# Parts

## Replacement Parts Listing (available from authorized Fulton Representative)

Part No.	Description	Approx. Net Weight (lbs.)	Approx. Net Weight (kgs.)
5-60-100	Instruction Manual, Fuel-Fired	2	0.91
5-60-165	Certification Papers		
5-60-164	Boiler Documentation for Export Boilers		
<b>Boiler Shell Parts</b>			
5-12-004	Furnace Refractory 8" OD x 2" ID (9.5 HP Top)	10	4.55
5-12-005	Furnace Refractory 8" OD x 2 1/2" ID (4 HP Gas Top - Old Style)	10	4.55
5-12-006	Furnace Refractory 8" OD x 3" ID (9.5 HP Bottom )	10	4.55
5-12-007	Furnace Refractory 10" OD x 3" ID (4-10 HP Top)	18	8.18
5-12-008	Furnace Refractory 10" OD x 3 1/2" ID (15 HP Top)	18	8.18
5-12-009	Furnace Refractory 10" OD x 5" ID (4-15 HP Bottom)	18	8.18
5-12-010	Furnace Refractory 15" OD x 5 1/2" ID (20 HP Top)	35	15.91
5-12-011	Furnace Refractory 15" OD x 6" ID (30 HP Top)	35	15.91
5-12-012	Furnace Refractory 15" OD x 7" ID (20 & 30 HP Bottom)	35	15.91
5-12-015	Furnace Refractory 24" OD x 8" ID (40 - 60 HP Top)	125	56.82
5-12-016	Furnace Refractory 24" OD X 10" ID (40- 60 HP Bottom)	125	56.82
5-12-017	Furnace Refractory 30" OD x 9 1/2" ID (80 HP Top)	225	102.27
2-12-000	Furnace Cement- 2 lb. can	2	0.91
2-12-001	Furnace Cement - 8 lb. can	8	3.64
2-12-002	Furnace Cement - 15 lb. can	15	6.82
5-10-353	Flue Cover Ring - 4 & 6 & 9.5 HP	19	8.64
5-10-354	Flue Cover Ring -10 HP	20	9.09
5-10-355	Flue Cover Ring - 15 HP	20.5	9.32
5-10-357	Flue Cover Ring - 20 HP	21	9.55
5-10-359	Flue Cover Ring - 30 HP	25	11.36
5-10-360	Flue Cover Ring - 40-60 HP	40	18.18
5-12-001	Bottom Cleanout Access Plate with Plug 4-30 HP	10	4.55
5-12-002	Bottom Cleanout Access Plate with Plug 40-60 HP	20	9.09
5-12-003	Square Cleanout Plug (Not for Series E)	15	6.82
2-12-064	Flexitalic (HHG) Extra Heavy High Pressure	0.5	0.23
2-12-088	Blue Max HHG	0.05	0.02
5-10-800	Handhole Welding Patch 4-60 HP	1.1	0.5
2-12-004	Handhole Gasket 4-60 HP	0.05	0.02
2-11-105	HandholeYoke	1.5	0.68
2-11-100	3 x 4 Handhole Cover 4-10 HP (White)	2	0.91
2-11-101	3 x 4 Handhole Cover 15 HP (Red) .	2	0.91
2-11-102	3 x 4 Handhole Cover 20 HP (Green)	2	0.91
2-11-103	3 x 4 Handhole Cover 30 HP (Yellow)	2	0.91
2-11-104	3 x 4 Handhole Cover 40-100 HP (Blue)	2	0.91
4-11-010	10 HP Handhole Assembly (White)	7	3.18
4-11-012	15 HP Handhole Assembly (Red)	7	3.18
4-11-014	20 HP Handhole Assembly (Green)	7	3.18
4-11-016	30 HP Handhole Assembly (Yellow)	7	3.18
4-11-018	40 -60 HP Handhole Assembly (Blue)	7	3.18
2-12-504	Blanket Insulation (Sq. ft.)	0.5	0.23
5-21-300	Steel Jacket 4 HP - No Holes Cut	80	36.36
5-21-301	Steel Jacket 6 HP - No Holes Cut	80	36.36

# Parts

Part No.	Description	Approx. Net Weight (lbs.)	Approx. Net Weight (kgs.)
5-21-302	Steel Jacket 10 HP - No Holes Cut	100	45.45
5-21-303	Steel Jacket 15 HP - No Holes Cut	115	52.27
5-21-304	Steel Jacket 20 HP - No Holes Cut	125	56.82
5-21-305	Steel Jacket 30 HP - No Holes Cut	125	56.82
5-21-306	Steel Jacket 40-60 HP - No Holes Cut	125	56.82
5-21-5064	Bottom Handhole Funnel 4 & 6 HP	6.5	2.95
5-21-5066	Bottom Handhole Funnel 10 HP	6.5	2.95
5-21-5068	Bottom Handhole Funnel 15 HP	6.5	2.95
5-21-5070	Bottom Handhole Funnel 20 HP	6.5	2.95
5-21-5072	Bottom Handhole Funnel 30 HP	6.5	2.95
5-21-5074	Bottom Handhole Funnel 40 & 60 HP	6.5	2.95
5-21-5063	Top Handhole Funnel 4 & 6 HP	6.5	2.95
5-21-5065	Top Handhole Funnel 10 HP	6.5	2.95
5-21-5067	Top Handhole Funnel 15 HP	6.5	2.95
5-21-5069	Top Handhole Funnel 20 HP	6.5	2.95
5-21-5071	Top Handhole Funnel 30 HP	6.5	2.95
5-21-5073	Top Handhole Funnel 40 - 60 HP	6.5	2.95
123	Bottom Funnel Repair Kits 4-15 HP	9.5	4.32
123	Bottom Funnel Repair Kits 20-30 HP	9.5	4.32
123	Bottom Funnel Repair Kits 40-60 HP	9.5	4.32
123	Top Funnel Repair Kits 4-15 HP	9.5	4.32
123	Top Funnel Repair Kits 20-30 HP	9.5	4.32
123	Top Funnel Repair Kits 40-60 HP	9.5	4.32
2-21-053	6" Stack Connection 4-10 HP	6.5	2.95
2-21-054	8" Stack Connection 15 HP	7	3.18
2-21-055	10" Stack Connection 20 HP	7.5	3.41
2-21-056	12" Stack Connection 30-60 HP	8	3.64
2-21-058	6" Stack to Pipe Adaptor 4-10 HP	6.5	2.95
2-21-059	8" Stack to Pipe Adaptor 15 HP	7	3.18
2-21-060	10" Stack to Pipe Adaptor 20 HP	8	3.64
2-21-061	12" Stack to Pipe Adaptor 30-60 HP	9	4.09
2-12-501	Castable Block Mix - per lb. (10 lbs. min.)-Use for top of bottom handhole up		
2-12-498	Castable Block Mix - 25 lb. bag -Use for top of bottom handhole up		
2-12-502	Kast Set - per lb. (10 lbs. minimum) - Use for making refractories		
2-12-500	Insulcrete - per lb. (10 lbs. min.) - Use for top of bottom handhole down		
2-12-497	Insulcrete - 50 lb. bag - Use for top of bottom handhole down		
5-12-020	Kaowool Sleeve for Bottom Funnel	0.9	0.41
4-12-018	Kaowool Insulation per sq. ft.		
2-12-507	Kaowool (panels) 7"		
2-21-015	Buckeye Stamping for Bottom Handhole 4-100 HP	1	0.45
2-21-092	Buckeye Stamping for Upper Handhole 4-15 HP	1	0.45
2-21-093	Buckeye Stamping for Upper Handhole 20-100 HP	1	0.45
2-23-171	Touch Up Paint - MICA Spray	1	0.45
4-23-014	Mica Paint - Quart	2	0.91
4-23-044	Mica Paint - Gallon	7.8	3.55
2-12-504	TIW Filler Insulation per sq ft		

# Parts

Part No.	Description	Approx. Net Weight (lbs.)	Approx. Net Weight (kgs.)
<b>Burner Assembly - Parts (Common)</b>			
2-40-605	1/3 HP 115/230/60/1 Burner Motor 3450 RPM	21	9.55
2-40-606	1/3 HP 230/460/60/3 Burner Motor 3450 RPM	20	9.09
2-40-603	1/3 HP 110/220/50/1 Burner Motor 2850 RPM	25	11.36
2-40-770	1/3 HP 380/50/3 Burner Motor 2850 RPM	28	12.73
<a href="#">2-40-608</a>	3/4 HP 115/230/60/1 Burner Motor 3450 RPM	25	11.36
2-40-611	3/4 HP 230/460/60/3 Burner Motor 3450 RPM	22	10
2-40-609	3/4 HP 110/220/50/1 Burner Motor 2850 RPM	28	12.73
2-40-610	3/4 HP 380/50/3 Burner Motor 2850 RPM	22	10
2-40-613	1.5 HP 115/230/60/1 Burner Motor 3450 RPM	40	18.18
2-40-614	1.5 HP 110/220/50/1 Burner Motor 2850 RPM	45	20.45
2-40-615	1.5 HP 230/460/60/3 Burner Motor 2850/3450 RPM	31	14.09
<a href="#">2-40-771</a>	1.5 HP 380/50/3 Burner Motor 2850 RPM	48	21.82
2-40-773	2.0 HP 380/50/3 Burner Motor 2850 RPM	48	21.82
2-40-616	2.0 HP 115/230/60/1 Burner Motor 3450 RPM	43	19.55
2-40-618	2.0 HP 230/460/60/3 Burner Motor 3450 RPM	33	15
2-40-617	2.0 HP 110/220/50/1 Burner Motor 2850 RPM	48	21.82
2-12-014	Pyrex Plate Glass 1 " - 4 -100 HP	0.1	0.05
<a href="#">2-45-025</a>	Bakelite Terminal 90° for Electrode	0.05	0.02
2-45-026	Bakelite Terminal Straight for Electrode	0.05	0.02
<a href="#">2-45-017</a>	Ignition Wire - per foot	0.01	0
2-11-116	Burner Scroll Casting - 9.5 HP	14	6.36
2-11-123	Burner Scroll Casting- 4-15 HP	30	13.64
5-20-059	Burner Scroll Casting - 20 HP	35	15.91
5-20-060	Burner Scroll Casting - 30 HP	40	18.18
5-20-061	Burner Scroll Casting - 40, 50 & 60 HP	50	22.73
<b>Burner Fans:</b>			
	<b>Size HP</b>	<b>Applicable Fuel</b>	<b>Hz.</b>
2-30-407	5-1/2 x 1-1/2 x 5/8	4 HP 6 HP	Propane or Nat. Gas Propane
			50/60 HZ
			50/60 HZ
2-30-410	6-1/4 x 1-1/2 x 5/8	6 HP	Combination or Natural Gas
			50/60 HZ
2-30-412	7 x 1-1/2 x 5/8	9.5-10 HP	Propane or Nat. Gas
			50/60 HZ
2-30-414	7-11/16 X 1-1/2 x 5/8	15-20 HP	Propane or Nat. Gas
			50/60 HZ
2-30-418	8-3/8 x 2 x 5/8	30 HP	Propane or Nat. Gas
			50/60 HZ
2-30-421	8-3/8 x 2-1/2 x 1	40-50 HP 60 HP	Propane or nat. Gas Propane or nat. Gas
			50/60 HZ.
			50/60 HZ.
			3.00
			1.36
			3.00
			1.36
*When ordering burner fans, check for the correct part number on the back of the fan plate.			
<b>Burner Assembly - Gas</b>			
<a href="#">2-40-082</a>	Ignition Transformer - Gas 115/60	9.5	4.32
2-40-083	Ignition Transformer - Gas 240/60	9.5	4.32
2-40-084	Ignition Transformer - Gas 120/50	10.3	4.68
2-40-085	Ignition Transformer - Gas 220/50	10.2	4.64
2-45-026	Straight Bakelite Terminal	0.03	0.01
4-45-010	Ignition Cable with 90° Bakelite Terminal	0.5	0.23
<a href="#">4-45-012</a>	Flame Rod Cable with 90° Bakelite Terminal	0.5	0.23
<a href="#">2-20-019</a>	Ignition Electrode	0.4	0.18
<a href="#">2-20-020</a>	Flame Rod	0.4	0.18

# Parts

Part No.	Description	Approx. Net Weight (lbs.)	Approx. Net Weight (kgs.)
<a href="#">2-30-118</a>	Air Switch 4-100 HP	0.72	0.33
5-20-019	Burner Plate Gas - 4 HP	1	0.45
5-20-007	Burner Plate Gas - 6 & 10 HP	1	0.45
5-20-055	Burner Plate Gas - 9.5 HP	2	0.91
5-20-013	Burner Plate Gas - 15 & 20 HP	1	0.45
5-20-018	Burner Plate Gas - 30-60 HP	1	0.45
2-11-112	Air Deflector - Gas - 6 & 10 HP	11	5.00
2-11-075	Air Deflector - Gas - 9.5 HP	11	5.00
2-11-113	Air Deflector - Gas -15 HP	11	5.00
7-20-088	Air Deflector - Gas - 20 HP	24	10.91
7-20-090	Air Deflector - Gas - 30 HP	24	10.91
7-20-092	Air Deflector - Gas 40 - 60 HP	45	20.45
2-40-533	Gas Pressure Switch High-Low	3.25	1.48
2-40-211	Gas Pressure Switch - Low	4.9	2.23
2-40-212	Gas Pressure Switch - High	4.8	2.18
<a href="#">2-30-298</a>	1/2" Pilot Gas Valve (4-100 HP)	1.5	0.68
2-30-301	1 " Main Gas Valve - V48A	3.2	1.45
<a href="#">2-30-302</a>	1-1/4 " Main Gas Valve - V48A	4	1.82
2-30-303	1-1/2" Main Gas Valve - V48A	4.5	2.05
2-30-312	1-1/2" Gas Valve V5055A	4	1.82
2-30-313	2" Gas Valve V5055A	9.2	4.18
2-40-249	Gas Valve Body - P.O.C V5055C 1"	5	2.27
2-40-252	Gas Valve Body - P.O.C V5055C 1-1/4"	5.1	2.32
2-40-253	Gas Valve Body - P.O.C V5055C 1-1/2"	4.7	2.14
2-40-254	Gas Valve Body - P.O.C V5055C 2"	9.3	4.23
2-40-214	Actuator for 2", 2-1/2" and 3" Valve Body	13.70	6.23
2-40-220	Actuator for 2", 2-1/2" and 3" Valve Body w/Proof of Closure Switch	12.8	5.82
2-30-400	3/4" Vent Valve - 120V Normally Open	3.2	1.45
2-30-401	1" Vent Valve - 120V Normally Open	4.3	1.95
2-30-402	1-1/4" Vent Valve - 120V Normally Open	4.7	2.14
2-30-305	3/4" Solenoid Gas Valve	1.8	0.82
2-30-306	1" Solenoid Gas Valve	3.9	1.77
2-30-307	1-1/4" Solenoid Gas Valve	3.9	1.77
2-30-308	1-1/2" Solenoid Gas Valve	4.4	2.00
2-30-198	1/8" Gas Cock (Pet Cock)	0.25	0.11
2-30-111	1/2" Pilot Gas Cock	0.6	0.27
2-30-112	3/4" Main Gas Cock	1.5	0.68
2-30-113	1" Main Gas Cock	2	0.91
2-30-114	1-1/4 " Main Gas Cock	3	1.36
2-30-115	1-1/2 " Main Gas Cock	4.8	2.18
2-30-116	2" Main Gas Cock	4.8	2.18
2-30-021	1" Lubricated Gas Cock	5	2.27
2-30-022	1-1/4" Lubricated Gas Cock	6.5	2.95
2-30-013	1-1/2" Lubricated Gas Cock	7	3.18
2-30-012	2" Lubricated Gas Cock	10	4.55

# Parts

Part No.	Description	Approx. Net Weight (lbs.)	Approx. Net Weight (kgs.)
2-30-102	1/2" Gas Pressure Regulator RV 48	0.7	0.32
2-30-104	1" Gas Pressure Regulator - RV 53	1.5	0.68
2-30-105	1-1/4 " Gas Pressure Regulator - RV 61	5	2.27
2-30-106	1-1/4" Gas Pressure Regulator - RV 81	5	2.27
2-30-107	1-1/2"Gas Pressure Regulator - RV 81	4.8	2.18
2-30-108	2" Gas Pressure Regulator - RV 91	8.3	3.77
2-20-002	CSA Air Gas Mixing Valve	1	0.45
7-20-060	Natural Gas Orifice - 4 HP Pre 2/89 3/4"	2	0.91
7-20-050	Natural Gas Orifice - 4 HP - Post 2/89 1"	2	0.91
7-20-051	Natural Gas Orifice - 6 HP	2	0.91
7-20-078	Natural Gas Orifice - 9.5 HP	2	0.91
7-20-052	Natural Gas Orifice -10 HP	2	0.91
7-20-023	Natural Gas Orifice - 15 HP - Post 2/89 1"	2	0.91
7-20-053	Natural Gas Orifice -15 HP - Pre 2/89 1-1/4"	2.5	1.14
7-20-054	Natural Gas Orifice - 20 HP	3	1.36
7-20-055	Natural Gas Orifice - 30 HP	3	1.36
7-20-265	Natural Gas Orifice - 40 HP	3.5	1.59
7-20-056	Natural Gas Orifice - 50 HP	3.5	1.59
7-20-057	Natural Gas Orifice - 60 HP	3.5	1.59
7-20-060	Propane Orifice - 4 HP - Pre 2/89 3/4"	2	0.91
7-20-030	Propane Orifice - 4 HP - Post 2/89 1"	2	0.91
7-20-061	Propane Orifice - 6 HP	2	0.91
7-20-062	Propane Orifice - 10 HP	2	0.91
7-20-033	Propane Orifice - 15 HP - Post 2/89 1"	2	0.91
7-20-063	Propane Orifice -15 HP - Pre 2/89 1-1/4"	2.5	1.14
7-20-064	Propane Orifice - 20 HP	3	1.36
7-20-065	Propane Orifice - 30 HP	3	1.36
7-20-275	Propane Orifice - 40 HP	3.5	1.59
7-20-066	Propane Orifice - 50 HP	3.5	1.59
7-20-067	Propane Orifice - 60 HP	3.5	1.59
2-30-177	Propane Spring RV48	0.05	0.02
2-30-178	Propane Spring RV53	0.05	0.02
2-30-179	Propane Spring RV61	0.05	0.02
2-30-180	Propane Spring RV81	0.05	0.02
2-30-181	Propane Spring RV91	0.05	0.02
7-30-001	Top Plate Assembly - 4 HP - Natural Gas	10	4.55
7-30-002	Top Plate Assembly - 6 & 10 HP - Natural Gas	15	6.82
5-30-001	Top Plate Assembly 9.5 HP - Natural Gas	15	6.82
7-30-003	Top Plate Assembly - 15 HP - Natural Gas	15	6.82
7-30-004	Top Plate Assembly - 20 HP - Natural Gas	35	15.91
7-30-005	Top Plate Assembly - 30 HP - Natural Gas	35	15.91
7-30-006	Top Plate Assembly - 40, 50 & 60 HP - Natural or Propane Gas	65	29.55
7-30-020	Top Plate Assembly - 4 HP - Propane Gas	10	4.55
7-30-021	Top Plate Assembly - 6 & 10 HP - Propane Gas	15	6.82
7-30-022	Top Plate Assembly - 15 HP - Propane Gas	15	6.82
7-30-023	Top Plate Assembly - 20 HP - Propane Gas	35	15.91
7-30-024	Top Plate Assembly - 30 HP - Propane Gas	35	15.91

# Parts

Part No.	Description	Approx. Net Weight (lbs.)	Approx. Net Weight (kgs.)
7-30-025	Burner Plate Assembly - 4 HP - Natural Gas	7	3.18
7-30-026	Burner Plate Assembly - 6 HP - Natural Gas	8	3.64
7-30-123	Burner Plate Assembly - 9.5 HP Natural Gas	8	3.64
7-30-027	Burner Plate Assembly - 10 HP - Natural Gas	8	3.64
7-30-028	Burner Plate Assembly - 15 HP - Natural Gas	8	3.64
7-30-029	Burner Plate Assembly - 20 HP - Natural Gas	10	4.55
7-30-030	Burner Plate Assembly - 30 HP - Natural Gas	10	4.55
7-30-031	Burner Plate Assembly - 40, 50 HP - Natural Gas	12	5.45
7-30-032	Burner Plate Assembly - 60 Hp - Natural Gas	12	5.45
7-30-053	Burner Plate Assembly - 4 HP - Propane Gas	7	3.18
7-30-054	Burner Plate Assembly - 6 HP - Propane Gas	8	3.64
7-30-055	Burner Plate Assembly - 10 HP - Propane Gas	8	3.64
7-30-056	Burner Plate Assembly - 15 HP - Propane Gas	8	3.64
7-30-057	Burner Plate Assembly - 20 HP - Propane Gas	10	4.55
7-30-058	Burner Plate Assembly - 30 HP - Propane Gas	10	4.55
7-30-059	Burner Plate Assembly - 40, 50 HP - Propane Gas	12	5.45
7-30-060	Burner Plate Assembly - 60 HP - Propane Gas	12	5.45
7-54-1000	Gas Train Assembly- 4 HP - Natural Gas	20	9.09
7-54-1001	Gas Train Assembly - 6 HP- Natural Gas	23	10.45
7-54-1002	Gas Train Assembly -10 HP - Natural Gas	23	10.45
7-54-1003	Gas Train Assembly - 15 HP - Natural Gas - 1"	23	10.45
7-54-1004	Gas Train Assembly - 20 HP - Natural Gas - 1-1/4"	27	12.27
7-54-1005	Gas Train Assembly - 30 HP - Natural Gas	27	12.27
7-54-1006	Gas Train Assembly - 40 - 50 HP - Natural Gas	70	31.82
7-54-1007	Gas Train Assembly- 60 HP- Natural Gas	70	31.82
7-54-1050	Gas Train Assembly - 4 HP - Propane Gas	20	9.09
7-54-1051	Gas Train Assembly - 6 HP - Propane Gas	25	11.36
7-54-1052	Gas Train Assembly -10 HP - Propane Gas	25	11.36
7-54-1053	Gas Train Assembly -15 HP - Propane Gas	25	11.36
7-54-1054	Gas Train Assembly - 20 HP - Propane Gas	30	13.64
7-54-1055	Gas Train Assembly - 30 HP - Propane Gas	30	13.64
7-54-1056	Gas Train Assembly - 40 - 50 HP - Propane Gas	70	31.82
7-54-1057	Gas Train Assembly - 60 HP - Propane Gas	70	31.82
<b>Water Column</b>			
5-20-022	Fulton Water Column Bottle Casting -4-100 HP	20	9.09
2-30-151	MM 150 Pump Control	25	11.36
2-30-193	MM 150 - M/R Control	25	11.36
2-30-152	MM 150 HD Assembly	25	11.36
2-30-192	MM 150-M-HD M/R Head	25	11.36
2-12-125	MM 150-14 Gasket	0.05	0.02
2-30-136	MM 157 Pump Control and Low Water Cutoff	39.7	18.05
2-30-137	MM 53-2 Boiler Feeder and Low Water Cutoff	38.5	17.5
2-45-144	MM Mercury Switch - 2 Wire	1	0.45
2-45-143	MM Mercury Switch - 3 Wire	1	0.45
2-30-149	Water Gauge Glass Valves w/Ball Checks	1.5	0.68
<a href="#">2-30-047</a>	Try Cocks	0.4	0.18
<a href="#">2-12-065</a>	8-5/8" Extra Heavy Gauge Glass	0.05	0.02
2-12-008	9-1/4 Water Gauge Glass - standard	0.05	0.02
<a href="#">2-12-007</a>	9-1/4" Extra Heavy Gauge Glass	0.1	0.05
<a href="#">2-12-017</a>	9-1/4" Water Gauge Glass -Corning	0.05	0.02

# Parts

Part No.	Description	Approx. Net Weight (lbs.)	Approx. Net Weight (kgs.)
2-12-018	10" Water Gauge Glass- MM	0.06	0.03
2-12-071	12" Water Gauge Glass	0.07	0.03
2-12-063	14"Water Gauge Glass	0.08	0.04
2-30-155	Conbraco 250# GG Valve w/Ball Check (9.5 HP)	1.5	0.68
2-12-020	Brass Water Gauge Glass Gasket	0.0018	0
<a href="#">2-12-019</a>	Rubber Water Gauge Glass Gasket	0.004	0
<a href="#">2-12-080</a>	Teflon Water Gauge Gaskets	0.01	0
<a href="#">2-35-514</a>	Brass Packing Nut for Gauge Glass Valve	0.1	0.05
2-30-330	Gauge Glass Protector Rods	0.04	0.02
2-12-022	Lucite Gauge Glass Guard for 9-1/4" Glass	0.4	0.18
2-12-024	Lucite Gauge Glass Guard for 10" Glass	0.5	0.23
2-12-021	Lucite Gauge Glass Guard for 12" Glass (53MM)	0.06	0.03
2-12-204	Lucite Gauge Glass Guard - 9.5 HP	0.045	0.02
4-21-010	Water Column Electrode Basket & Cover	0.5	0.23
4-30-050	Set of four (4) Water Level Probes & Plugs - 4 HP	1.3	0.59
<a href="#">4-30-052</a>	Set of four (4) Water Level Probes & Plugs - 6-60 HP	1.3	0.59
<a href="#">4-30-042</a>	Set of 3 Water Column Probes	0.8	0.36
<a href="#">2-20-010</a>	Pump Off Probe - 7-1/4 "	0.2	0.09
<a href="#">2-20-011</a>	Pump On Probe - 9-1/4"	0.2	0.09
<a href="#">2-20-012</a>	Low Water Probe in Water Column -11-1/4"	0.3	0.14
2-20-017	Low Water Probe in Boiler- 17-1/8"	0.5	0.23
2-21-012	Probe Cover - 2"	1	0.45
2-21-013	Probe Cover - 4"	1	0.45
2-30-398	1/4"Male-Female Ball Valve for Water Column	0.6	0.27
2-40-021	Probe Basket	0.05	0.02
<b>Panel Box Parts</b>			
<a href="#">2-40-420</a>	Fulton Pump Relay-120V	0.5	0.23
<a href="#">2-40-421</a>	Fulton Burner Relay - 120V	0.5	0.23
2-40-422	Base for Fulton Pump Relay	0.25	0.11
2-40-423	Base for Fulton Burner Relay	0.25	0.11
2-40-405	Fulton Pump Relay - 220v	0.5	0.23
<a href="#">2-40-406</a>	Fulton Burner Relay - 220v	0.5	0.23
2-12-090	Spring Retainer for burner/pump relay	0.001	0
2-40-403	IDIDO-120VRelay 2		0.91
2-40-402	IGIDO - 120V Relay	2	0.91
2-40-400	IGIDO-A-120VRelay 2		0.91
2-40-401	ID2DO - 220V Relay	2	0.91
4-45-050	Set of three (3) Coils for ID or IG Type Relay	1	0.45
4-45-051	Set of three (3) Coils ID2D0 - 220V	1	0.45
2-40-131	General Purpose Relay (Ice Cube) - AB	0.8	0.36
2-40-096	Base for Ice Cube Relay	0.1	0.05
2-45-091	On/Off Switch	0.05	0.02
2-45-092	Manual Reset Switch	0.05	0.02
2-45-090	Night Switch for two (2) Pressuretrols	0.05	0.02
2-40-552	4" Alarm Bell	1	0.45
2-40-551	120V Transformer for Bell	1	0.45
2-40-550	220V Transformer for Bell	1	0.45

# Parts

Part No.	Description	Approx. Net Weight (lbs.)	Approx. Net Weight (kgs.)
2-45-106	Green Panel Box Indicating Light - 120V	0.1	0.05
2-45-107	White Panel Box Indicating Light -120V	0.1	0.05
2-45-108	Amber Panel Box Indicating Light - 120V	0.1	0.05
2-45-110	Red Panel Box Indicating Light -120V	0.1	0.05
2-45-112	Green Panel Box Indicating Light - 220V	0.1	0.05
2-45-115	White Panel Box Indicating Light - 220V	0.1	0.05
2-45-116	Amber Panel Box Indicating Light - 220V	0.1	0.05
2-45-114	Red Panel Box Indicating Light - 220V	1	0.45
<a href="#">2-45-412</a>	AB Green Panel Light 120 V - NEMA 4	0.02	0.01
2-45-413	AB Amber Panel Light 120 V - NEMA 4	0.02	0.01
2-45-411	AB Red Panel Light 120 V - NEMA 4	0.02	0.01
2-45-410	AB White Panel Light 120 V - NEMA 4	0.02	0.01
2-40-567	Motor Contactor - AB - 100 - A09ND3- 120V - 4-60 HP	0.8	0.36
2-40-568	Motor Contactor - AB - 100 - A09NA3- 220V - 4-60 HP	0.8	0.36
2-40-565	Overload - AB - BSB 16	0.45	0.2
2-40-657	Overload - AB - BSB 15	0.45	0.2
2-40-648	Overload - AB - BSB 22	0.45	0.2
2-40-571	Overload - AB - BSB 30	0.45	0.2
2-40-575	Overload - AB - BSC 10	0.45	0.2
2-40-643	Overload - AB - BSC 15	0.45	0.2
2-40-652	Overload - AB - BSC 24	0.45	0.2
2-40-572	Overload - AB - BSB 42	0.45	0.2
2-40-573	Overload - AB - BSB 60	0.45	0.2
2-40-574	Overload - AB - BSB 80	0.45	0.2
2-40-566	Overload - AB - BSB 90	0.45	0.2
2-40-200	Motor Starter Relay -120V - 20 AMP	0.6	0.27
2-40-202	Motor Starter Relay - 120V - 30 AMP	0.5	0.23
2-40-201	Motor Starter Relay - 220V - 20 AMP	0.4	0.18
2-40-203	Motor Starter Relay - 220V - 30 AMP	0.5	0.23
4-40-050	Night Heating Pressuretrol Set Up	3.5	1.59
2-40-227	Pressuretrol L404A - 2-15 PSI	1.7	0.77
<a href="#">2-40-228</a>	Pressuretrol L404A - 5-50 PSI	2	0.91
<a href="#">2-40-229</a>	Pressuretrol L404A - 10-150 PSI	2	0.91
2-40-230	Pressuretrol L404A - 20-300PSI	2.7	1.23
2-40-231	Pressuretrol L404C - 2-15 PSI	2	0.91
2-40-232	Pressuretrol L404C - 5-50 PSI	2	0.91
<a href="#">2-40-233</a>	Pressuretrol L404C - 10-150 PSI	2	0.91
2-40-234	Pressuretrol L404C - 20-300 PSI	2.7	1.23
<a href="#">2-40-161</a>	Flame Scanner (Mini-Peeper)	0.5	0.23
<a href="#">2-40-260</a>	RM7895A Programmer 20-50 HP - 120 V	2	.91
2-40-262	RM7800M Programmer 60-100 HP - 120 V	2.5	1.14
2-40-265	7 Second Prepurge Timer	0.1	0.05
2-40-266	30 Second Prepurge Timer	0.1	0.05
2-40-267	60 Second Prepurge Timer	0.1	0.05
2-40-268	RM7800 Amplifier - For Flame Rod	0.3	0.14
2-40-269	RM7800 Amplifier - For UV Amp	0.2	0.09

# Parts

Part No.	Description	Approx. Net Weight (lbs.)	Approx. Net Weight (kgs.)
<a href="#">2-40-161</a>	Mini Peeper For All 7800	0.5	0.23
<a href="#">2-40-270</a>	Base For All 7800	0.5	0.23
2-40-272	Display Module for 7800 Controls English (Also Available in Spanish)	0.5	0.23
2-40-247	Remote Mounting Bracket for 7800	0.65	0.3
2-40-248	Extension Cable		
2-40-261	EC7830A Programmer 220/50	2	0.91
2-40-276	Timer 7 for EC7830/50	0.1	0.05
2-40-273	Timer 30 for EC7830/50	0.1	0.05
2-40-274	UV - Amplifier for EC7830/50	0.2	0.09
<b>Boiler Trim</b>			
5-35-100	9.5 HP Steam Orifice	2	0.91
<a href="#">2-30-396</a>	1" Spring Loaded Check Valve - 200#	2.55	1.16
2-30-397	1-1/4" Spring Loaded Check Valve - 200#	3.8	1.73
2-30-019	1/4" Ball Valve - 200#	0.6	0.27
2-30-008	1/2" Ball Valve-200#	0.7	0.32
2-30-027	3/4" Ball Valve-200#	1.4	0.64
2-30-026	1" Ball Valve - 200#	1.75	0.8
2-30-001	1" MxF Ball Valve 200#	2	0.91
2-30-017	1-1/4" Ball Valve - 200#	3.1	1.41
2-30-018	1-1/2" Ball Valve - 200#	4.7	2.14
2-30-025	2" Ball Valve - 200#	6.35	2.89
2-30-208	3" Ball Valve - 200#	18	8.18
2-30-391	1"Y Type Blowdown Valve - 200#	4	1.82
2-30-392	1-1/4" Y Type Blowdown Valve - 200#	5.5	2.5
2-30-393	1-1/2" Y Type Blowdown Valve - 200#	8.4	3.82
2-30-007	1" Quick Action Blowdown Valve	13	5.91
2-30-014	1-1/4" Quick Action Blowdown Valve	14	6.36
2-30-023	1-1/2" Quick Action Blowdown Valve	23	10.45
2-40-133	Timer for Automatic Blowdown System	0.8	0.36
2-30-386	1" Motorized Valve for Automatic Blowoff	9.8	4.45
2-30-387	1-1/4" Motorized Valve for Automatic Blowoff	10.7	4.86
2-30-403	1-1/2" Motorized Valve for Automatic Blowoff	12.6	5.73
2-30-1066	1/2" Steam Solenoid Valve - 120V	2.3	1.05
2-30-122	3/4" Steam Solenoid Valve - 120V	2.5	1.14
2-30-146	1" Steam Solenoid Valve - 120V	4.5	2.05
2-30-147	1-1/4" Steam Solenoid Valve - 120V	4.9	2.23
2-30-148	1-1/2" Steam Solenoid Valve - 120V	6.3	2.86
2-30-214	3/4" 15# Series 19 V-Stamped Safety Valve	1	0.45
2-30-215	1" 15# Series 19 V-Stamped Safety Valve	1.1	0.5
2-30-216	1-1/4" 15# Series 19 V-Stamped Safety Valve	1.85	0.84
2-30-016	1-1/2" 15# Series 19 V-Stamped Safety Valve	2	0.91
2-30-217	2" 15# Series 19 V-Stamped Safety Valve	2.5	1.14
2-30-062	1/2"-100# Safety Valve	1.2	0.55
2-30-063	1/2"-125# Safety Valve	1.3	0.59
2-30-064	3/4"-15# Safety Valve	1	0.45
2-30-065	3/4"-30# Safety Valve	1.8	0.82
2-30-067	3/4"-75# Safety Valve	3.2	1.45

# Parts

Part No.	Description	Approx. Net Weight (lbs.)	Approx. Net Weight (kgs.)
<a href="#">2-30-068</a>	3/4"-100# Safety Valve	2	0.91
<a href="#">2-30-069</a>	3/4"-125# Safety Valve	2	0.91
<a href="#">2-30-070</a>	3/4"-150# Safety Valve	1.4	0.64
<a href="#">2-30-071</a>	3/4"-200# Safety Valve	5.1	2.32
<a href="#">2-30-073</a>	3/4"-300# Safety Valve	2.35	1.07
<a href="#">2-30-074</a>	1"-15# Safety Valve	1.1	0.5
<a href="#">2-30-075</a>	1"-75# Safety Valve	4	1.82
<a href="#">2-30-076</a>	1"-100# Safety Valve	4.1	1.86
<a href="#">2-30-077</a>	1"-125# Safety Valve	4.1	1.86
<a href="#">2-30-078</a>	1"-150# Safety Valve	4.1	1.86
<a href="#">2-30-079</a>	1"-200# Safety Valve	4	1.82
<a href="#">2-30-081</a>	1"-300# Safety Valve	5	2.27
<a href="#">2-30-082</a>	1-1/4 "-15# Safety Valve	1.85	0.84
<a href="#">2-30-083</a>	1-1/4"-100# Safety Valve	6.6	3
<a href="#">2-30-084</a>	1-1/4"-125# Safety Valve	6.75	3.07
<a href="#">2-30-085</a>	1-1/4"-150# Safety Valve	6.8	3.09
<a href="#">2-30-086</a>	1-1/2"-15# Safety Valve	2	0.91
<a href="#">2-30-087</a>	1-1/2"-100# Safety Valve	12.4	5.64
<a href="#">2-30-088</a>	1-1/2"-125# Safety Valve	10.9	4.95
<a href="#">2-30-089</a>	1-1/2"-150# Safety Valve	12.3	5.59
<a href="#">2-35-518</a>	1/4" Steel Pigtail Syphon for Steam Gauge Assembly- Long	0.6	0.27
<a href="#">2-30-202</a>	Pressure & Temp Gauge	1	0.45
<a href="#">2-30-326</a>	0-30 PSI Steam Pressure Gauge	0.5	0.23
<a href="#">2-30-334</a>	0-60 PSI Steam Pressure Gauge	0.5	0.23
<a href="#">2-30-333</a>	0-200 PSI Steam Pressure Gauge	0.5	0.23
<a href="#">2-30-332</a>	0-300 PSI Steam Pressure Gauge	0.5	0.23
<a href="#">2-30-327</a>	0-600 PSI Steam Pressure Gauge	0.5	0.23
<a href="#">2-12-025</a>	Teflon Disc for 1" Y Valve	0.2	0.09
<a href="#">2-11-015</a>	Brass Seat for 1" Y Valve	0.1	0.05
<a href="#">2-12-026</a>	Teflon Disc for 1-1/4 " Y Valve	0.5	0.23
<a href="#">2-11-016</a>	Brass Seat for 1-1/4 " Y Valve	0.1	0.05
<a href="#">2-12-027</a>	Teflon Disc for 1-1/2" Y Valve	0.2	0.09
<a href="#">2-11-017</a>	Brass Seat for 1-1/2" Y Valve	0.1	0.05
<a href="#">2-12-028</a>	Teflon Disc for 2" Y Valve	0.2	0.09
<a href="#">2-11-018</a>	Brass Seat for 2" Y Valve	0.1	0.05
<b>Test Equipment/Tools</b>			
<a href="#">2-40-090</a>	Test Leads	0.6	0.27
<a href="#">2-40-215</a>	Microampmeter - W136	2	0.91
<a href="#">2-60-100</a>	Jr. Amprobe - Y25	1	0.45
<a href="#">2-60-102</a>	Pocket Draft Meter	1	0.45
<a href="#">2-60-103</a>	All Purpose Draft Meter	3	1.36
<a href="#">2-60-104</a>	CO Tester-Gas	15	6.82
<a href="#">2-60-105</a>	CO Tubes	0.25	0.11
<a href="#">2-60-106</a>	StackThermometer 4		1.82
<a href="#">2-60-108</a>	SmokeTester-Oil 2		0.91
<a href="#">2-60-110</a>	Fisher Gauge - 50 PZ	1	0.45
<a href="#">2-60-112</a>	Flue Cleanout Brush	0.8	0.36
<a href="#">2-60-247</a>	Flue Brush - Pipe Type - 2-1/2" - 100 HP	1	0.45
<a href="#">2-60-248</a>	Flue Brush - Pipe Type - 2" - 80 HP	1	0.45

# Parts

Part No.	Description	Approx. Net Weight (lbs.)	Approx. Net Weight (kgs.)	
5-10-397	Tee Handle Wrench	2.7	1.23	
2-20-110	Fan Puller - 5/8" Hub	2	0.91	
2-20-115	Fan Puller - 1" Hub	2	0.91	
<b>Barometric Controls</b>				
2-30-092	6" MGI 4, 6 & 10 HP - Gas	3	1.36	
2-30-095	8" MG1 15 HP - Gas	4	1.82	
2-30-097	10" M&MG2 20 HP - Oil, Gas, Comb	8	3.64	
2-30-098	12" M&MG2 30 HP - Oil, Gas, Comb.	12	5.45	
2-30-099	14" M&MG2 50 - 100 HP - Oil, Gas, Comb.	16	7.27	
2-30-0415	16" M&MG2	25	11.36	
<b>Spare Parts Kits</b>				
4-50-000001	Spare Parts Kit No. 1	4-30 BHP Gas Consists of:	4	1.82
	Qty	Part No.	Description	
	6	<a href="#">2-12-000004</a>	Handhole Gaskets	
	1	<a href="#">2-12-000017</a>	9-1/4" Gauge Glass	
	2	<a href="#">2-12-000019</a>	Water Gauge Glass Rubber	
	2	<a href="#">2-12-000020</a>	Water Gauge Glass Fiber	
	1	<a href="#">2-20-000019</a>	Ignition Electrode	
	1	2-20-000020	Flame Rod	
	1	5-10-000397	Tee Handle Wrench	
	1	<a href="#">4-30-000052</a>	Set of (4) Plugs and Probes	
4-50-000002	Spare Parts Kit No. 2	50-100 BHP Gas	4	1.82
	6	<a href="#">2-12-000004</a>	Handhole Gaskets	
	1	<a href="#">2-12-000017</a>	9-1/4" Gauge Glass	
	2	<a href="#">2-12-000019</a>	Water Gauge Glass Rubber	
	2	<a href="#">2-12-000020</a>	Water Gauge Glass Fiber	
	1	<a href="#">2-20-000019</a>	Ignition Electrode	
	1	5-10-000397	Tee Handle Wrench	
	1	<a href="#">4-30-000052</a>	Set of (4) Plugs and Probes	
2-12-515	Burner Plate Gasket 4 HP Gas	0.05	0.02	
<a href="#">2-12-516</a>	Burner Plate Gasket 6-20 HP Gas	0.05	0.02	
2-12-517	Burner Plate Gasket 30-100 HP Gas	0.06	0.03	
2-12-023	Screws (11)	0.001	0.00	
<a href="#">2-12-513</a>	Bottom Cleanout Gasket Only	0.5	0.23	
2-12-514	Combination Gasket	0.05	0.02	
4-12-100	Flue Cover Plate Gasket - 4 HP	1.5	0.68	
4-12-102	Flue Cover Plate Gasket - 6 HP	1.5	0.68	
4-12-104	Flue Cover Plate Gasket -10 HP	1.5	0.68	
4-12-106	Flue Cover Plate Gasket -15 HP	1.8	0.82	
<a href="#">4-12-108</a>	Flue Cover Plate Gasket - 20 HP	2	0.9	
4-12-110	Flue Cover Plate Gasket - 30 HP	2	0.91	
4-12-112	Flue Cover Plate Gasket - 40-60 HP	2.5	1.14	
<a href="#">2-12-210</a>	1/4" Braided Rope Gasket 4-100 HP - price per foot	0.25	0.11	
2-12-077	Handhole Funnel Gasket 20-100 HP Top	0.05	0.02	
2-12-078	Handhole Funnel Gasket 4-15 HP Top	0.05	0.02	
2-12-079	Handhole Funnel Gasket 4-100 HP Bottom	0.05	0.02	

# Parts

Part No.	Description	Approx. Net Weight (lbs.)	Approx. Net Weight (kgs.)
2-12-528	Scroll Gasket - 4 HP	1	0.45
2-12-529	Scroll Gasket - 6-15 HP	1	0.45
2-12-530	Scroll Gasket- 20-30 HP	1	0.45
2-12-531	Scroll Gasket- 40-60 HP	1	0.45
2-12-537	Stack Extension Gasket 6" 4-10 HP	1	0.45
2-12-538	Stack Extension Gasket 8" 15 HP	1	0.45
2-12-539	Stack Extension Gasket 10" 20 HP	1	0.45
2-12-540	Stack Extension Gasket 12" 30-60 HP	1	0.45
2-12-518	Top Plate Gasket - 4 HP (Old Style)	1	0.45
<a href="#">2-12-519</a>	Top Plate Gasket - 4-15 HP	1	0.45
2-12-520	Top Plate Gasket - 20-30 HP	1	0.45
2-12-521	Top Plate Gasket - 40-60 HP	1	0.45
4-12-522	9.5 HP Gas, Oil, & Comb Gasket Kit	5	2.27
4-12-500	4-15 HP Gas, Oil, & Comb Gasket Kit	5	2.27
4-12-506	20-30 HP Gas, Oil, & Comb Gasket Kit	6	2.73
<a href="#">4-12-512</a>	40-60 HP Gas, Oil, & Comb Gasket Kit	10	4.55

See the following component assembly drawings to assist with parts identification.



# Parts

Part No.*	Burner Motor (1)	RPM	HP
2-40-605	1/3 HP 115/230/60/1	3450	4-15
2-40-606	1/3 HP 230/460/60/3	3450	4-15
2-40-603	1/3 HP 110/220/50/1	2850	4-15
2-40-770	1/3 HP 380/50/3	2850	4-15
<a href="#">2-40-608</a>	3/4 HP 115/230/60/1	3450	20-30
2-40-611	3/4 HP 230/460/60/3	3450	20-30
2-40-609	3/4 HP 110/220/50/1	2850	20-30
<a href="#">2-40-771</a>	1.5 HP 380/50/3	2850	40-60
2-40-613	1.5 HP 115/230/60/1	3450	40-60
2-40-615	1.5 HP 230/460/60/3	3450	40-60
2-40-614	1.5 HP 110/220/50/1	2850	40-60

\*The correct part number is located on the burner motor.

Part No.	Burner Scroll Casting (2)	HP
2-11-123	Burner Scroll Casting	4-15
5-20-059	Burner Scroll Casting	20
5-20-060	Burner Scroll Casting	30
2-11-126	Burner Scroll Casting	40-60

Part No.*	Burner Fan (3)	Fuel	HZ	HP
2-30-407	5-1/2 x 1-1/2 x 5/8	LP/N. Gas	50/60	4
		LP	50/60	6
2-30-410	6-1/4 x 1-1/2 x 5/8	N. Gas	50/60	6
2-30-412	7 x 1-1/2 x 5/8	LP/N. Gas	50/60	9.5-10
2-30-414	7-11/16 X 1-1/2 x 5/8	LP/N. Gas	50/60	15-20
2-30-418	8-3/8 x 2 x 5/8	LP/N. Gas	50/60	30
2-30-421	8-3/8 x 2-1/2 x 1	LP/N. Gas	50/60	40-50.
2-30-425	9 -3/16 X 2-1/2 x 1	LP/N. Gas	50/60	60

\*The correct part number is located on the back of the fan plate.

Part No.	Ignition Transformer (4)
<a href="#">2-40-082</a>	120/60/1
2-40-083	240/60/1
2-40-084	120/50/1
2-40-085	240/50/1

Part No.	Air Deflector (5)	HP
2-11-112	Air Deflector	4-10
2-11-075	Air Deflector	9.5
2-11-113	Air Deflector	15-20
7-20-090	Air Deflector	30
7-20-092	Air Deflector	40-60

Part No.	Nat. Gas Orifice	LP Gas Orifice (6)	HP
7-20-050		7-20-030	4
7-20-051		7-20-061	6
2-20-078		consult factory	9.5
7-20-052		7-20-062	10
<a href="#">7-20-023</a>		7-20-033	15
7-20-054		7-20-064	20
7-20-055		7-20-065	30
7-20-265		7-20-275	40
7-20-056		7-20-066	50
7-20-057		7-20-067	60

Part No.	Air Switch (7)	HP
<a href="#">2-30-118</a>		4-100

Part No.	Flame Detectors	HP
<a href="#">2-40-161</a>	Scanner for 7800 Series (8)	50-100
<a href="#">2-20-020</a>	Flame Rod (9)	4-30

Part No.	Burner Plate (10)	HP
5-20-019	Gas Burner Plate	4
5-20-007	Gas Burner Plate	6-10
5-20-055	Gas Burner Plate	9.5
5-20-013	Gas Burner Plate	15-20
5-20-018	Gas Burner Plate	30-60

Part No.	Air Gate (11)	HP
5-20-017	Air Gate	4-10
5-20-012	Air Gate	15
5-20-011	Air Gate	20-30
5-20-066	U.K. Air Gate	40-100

Part No.	Electrode Parts	HP
<a href="#">2-20-019</a>	Ignition Electrode (12)	4-60
<a href="#">2-20-033</a>	Ignition Electrode - VMP (13)	40-100
2-12-014	Pyrex Plate Glass 1" (14)	4-100

# Parts

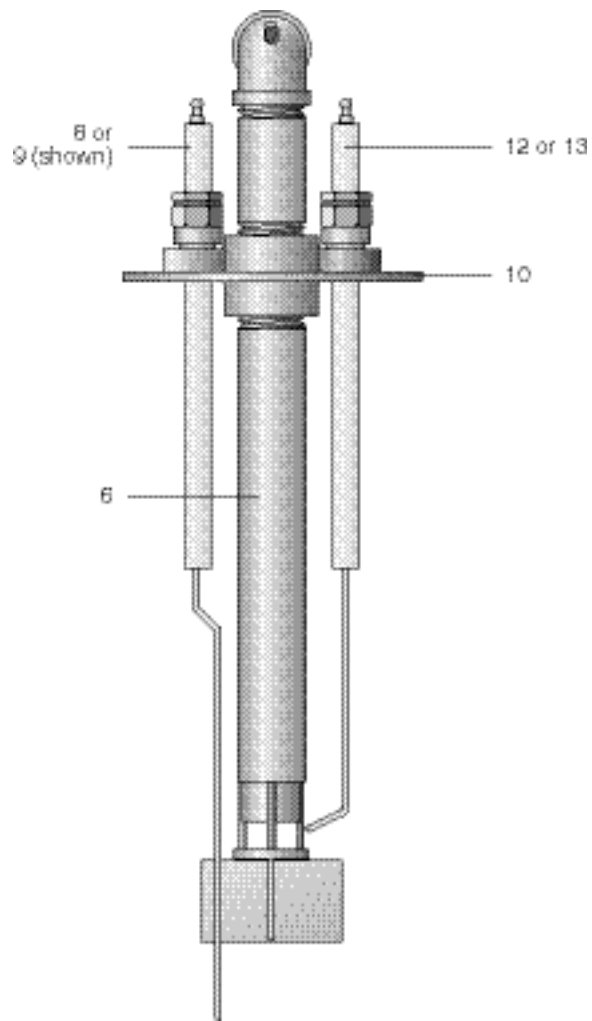

Gas Burner Ignition Assembly

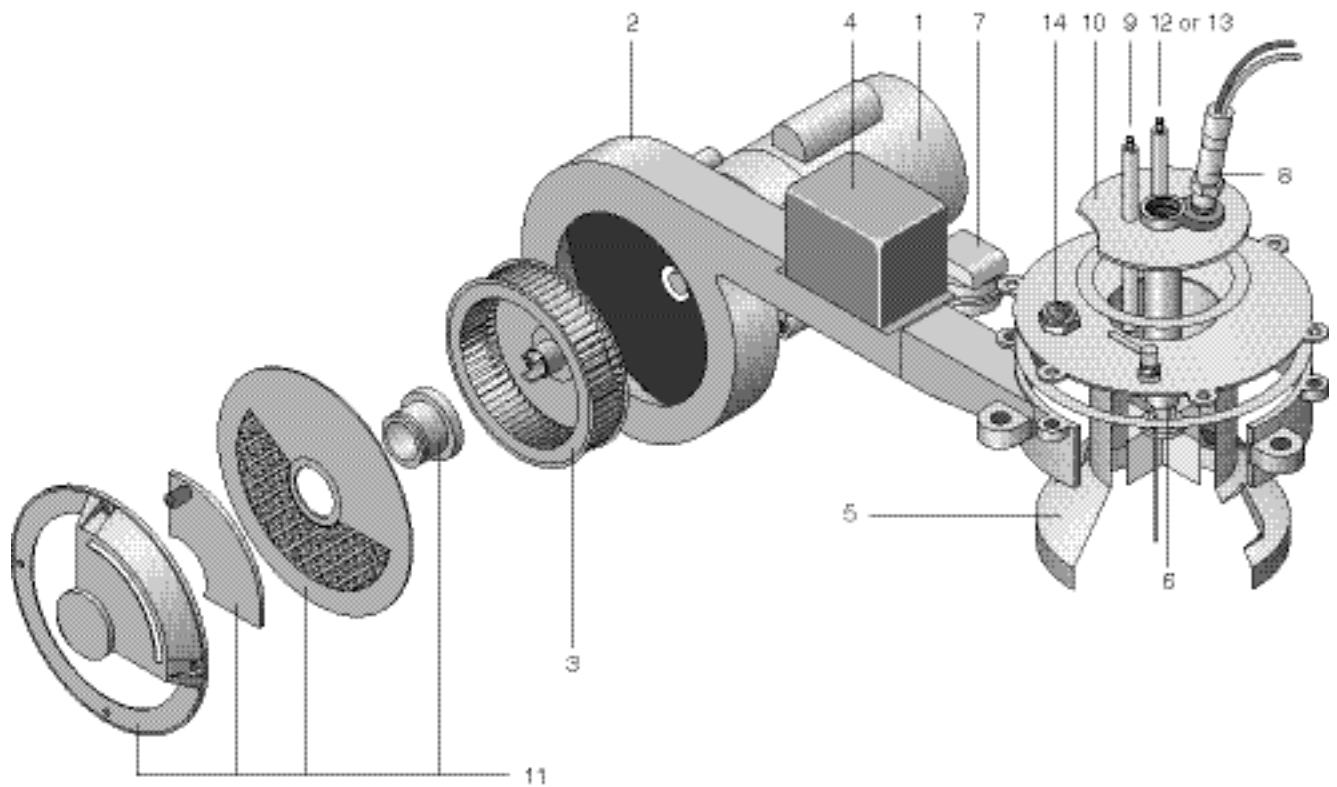

Gas Burner Components

# Parts

## Gas Head Assemblies

Part No.	Complete Gas Head Assembly	HP
7-54-1000	Natural Gas	4
7-54-1001	Natural Gas	6
7-54-1002	Natural Gas	10
7-54-1003	Natural Gas	15
7-54-1004	Natural Gas	20
7-54-1005	Natural Gas	30
7-54-1006	Natural Gas	40-50
7-54-1007	Natural Gas	60
7-54-1050	Propane Gas	4
7-54-1051	Propane Gas	6
7-54-1052	Propane Gas	10
7-54-1053	Propane Gas	15
7-54-1054	Propane Gas	20
7-54-1055	Propane Gas	30
7-54-1056	Propane Gas	40-50
7-54-1057	Propane Gas	60

## Gas Train Components

Part No.	Description	HP
2-30-113	Main Gas Manual Shut Off Valve <b>(1)</b>	4-15
2-30-114	Main Gas Manual Shut Off Valve	20
2-30-115	Main Gas Manual Shut Off Valve	30-50
2-30-116	Main Gas Manual Shut Off Valve	60
2-30-104	Main Gas Pressure Regulator <b>(2)</b>	4-15
2-30-105	Main Gas Pressure Regulator	20
2-30-107	Main Gas Pressure Regulator	30-50
2-30-108	Main Gas Pressure Regulator	60
2-30-301	Main Automatic Gas Valve <b>(3)</b>	4-15
<a href="#">2-30-302</a>	Main Automatic Gas Valve	20
2-30-303	Main Automatic Gas Valve	30-50
2-40-220	Main Automatic Gas Valve Actuator w/Proof of Closure <b>(4)</b>	60-100
2-40-254	Main Automatic Gas Valve Body <b>(5)</b>	60
2-30-198	Leak Test Valve <b>(6)</b>	4-100
2-40-533	High/Low Gas Pressure Switch <b>(7)</b>	60-100
2-30-113	Final Manual Shut-off Valve <b>(8)</b>	4-15
2-30-114	Final Manual Shut-off Valve	20
2-30-115	Final Manual Shut-off Valve	30-50
2-30-116	Final Manual Shut-off Valve	60
2-30-111	Pilot Gas Manual Shut-off Valve <b>(9)</b>	4-100
2-30-102	Pilot Gas Pressure Regulator <b>(10)</b>	4-100
<a href="#">2-30-298</a>	Pilot Gas Automatic Shut-off Valve <b>(11)</b>	4-100

# Parts

Gas Head Assembly (CSD-1)  
4 to 50 HP

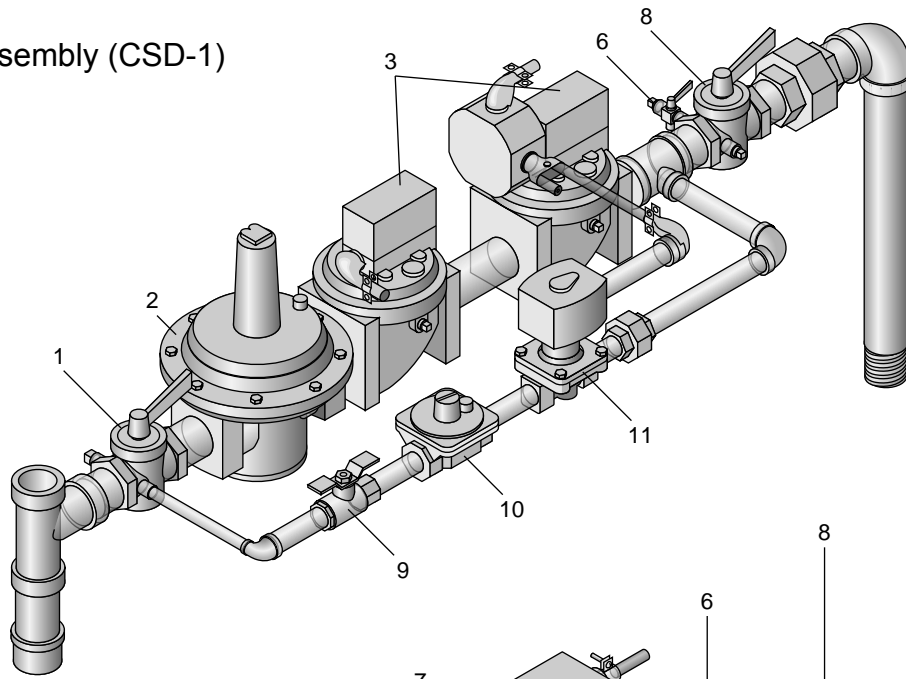

Gas Head Assembly (CSD-1)  
60 HP

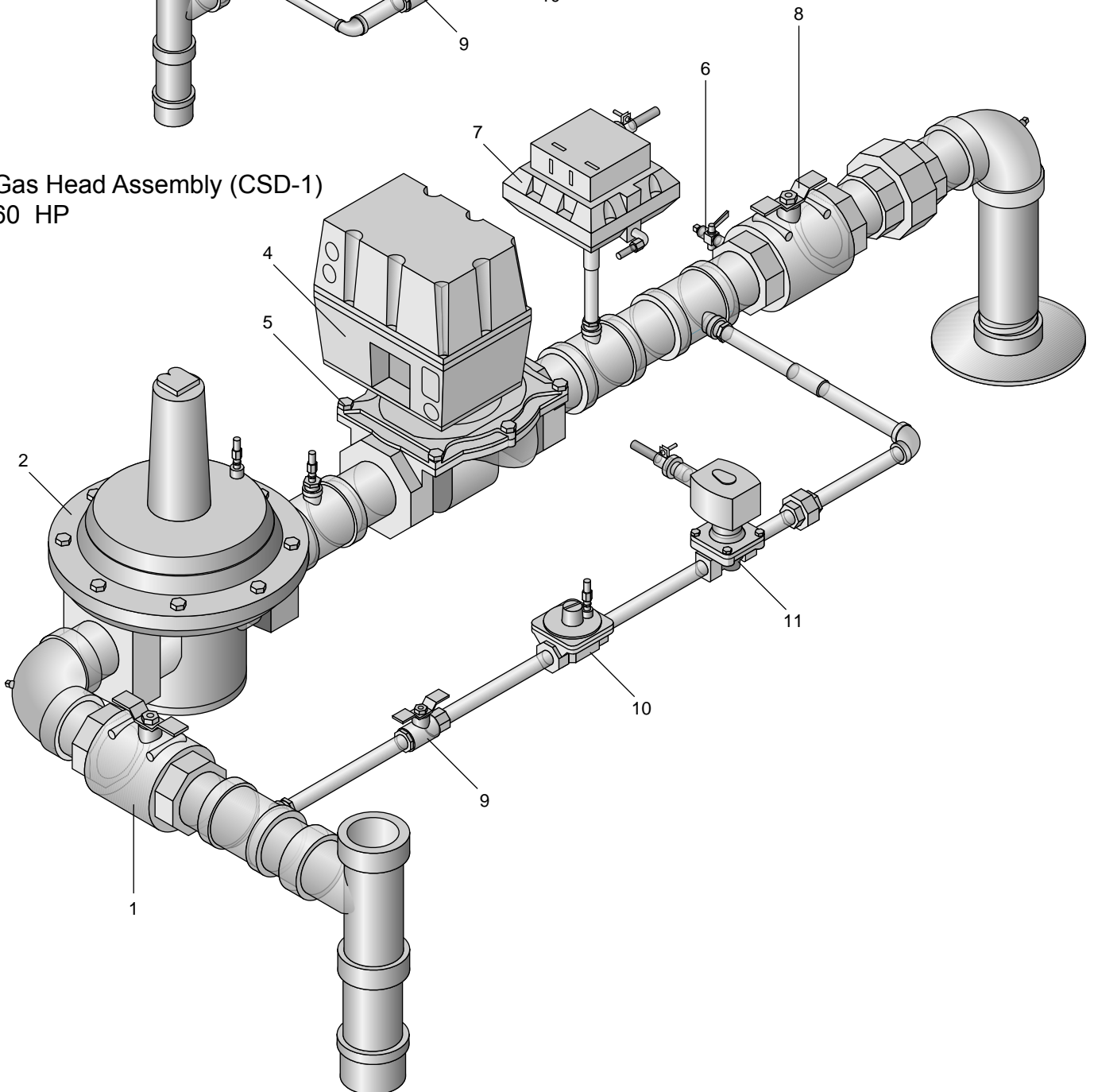

# Parts

## Panel Box Parts

Part No.	Relays	HP
<a href="#">2-40-420</a>	Fulton Pump Relay - 120V	4-100
<a href="#">2-40-421</a>	Fulton Burner Relay - 120V	4-100
2-40-422	Base for Fulton Pump Relay	4-100
2-40-423	Base for Fulton Burner Relay	4-100
2-40-405	Fulton Pump Relay 220V	4-100
<a href="#">2-40-406</a>	Fulton Burner Relay 220V	4-100
2-40-403	IDIDO-120V Relay	4-100
2-40-402	IGIDO - 120V Relay (manual reset)	4-100
2-40-400	IGIDO-A-120V Relay	4-100
2-40-401	ID2DO - 220V Relay	4-100

Part No.	Switches	HP
2-45-091	On/Off Switch	4-100
2-45-092	Manual Reset Switch	4-100
2-45-090	Night Switch for two (2) Pressuretrols	4-100

Part No.	Motor Starter Relays (Single Phase)	HP
2-40-200	Motor Starter Relay - 120V - 20 AMP	4-50
2-40-202	Motor Starter Relay - 120V - 30 AMP	4-50
2-40-201	Motor Starter Relay - 220V - 20 AMP	4-50
2-40-203	Motor Starter Relay - 220V - 30 AMP	4-50

Part No.	Flame Safeguard Control	HP
<a href="#">2-40-260</a>	RM7895F Programmer	4-50
2-40-262	RM7800M Programmer	60-100
2-40-272*	Display Module For 7800 Series Controls	60-100

Part No.	Motor Contactors (Three Phase)	HP
2-40-568	Contactor - AB -100- A09NA3- 220V	4-60
2-40-567	Contactor- AB -100- A09ND3-120V	4-60
2-40-641	Contactor -AB -100- A12NA3- 220V	80-100
<a href="#">2-40-642</a>	Contactor- AB -100- A12ND3-120V	80-100
2-40-565	Overload - AB - BSB 16	
2-40-657	Overload - AB - BSB 15	
2-40-648	Overload - AB - BSB 22	
2-40-571	Overload - AB - BSB 30	
2-40-575	Overload - AB - BSC 10	
2-40-643	Overload - AB - BSC 15	
2-40-652	Overload - AB - BSC 24	
2-40-572	Overload - AB - BSB 42	
2-40-573	Overload - AB - BSB 60	
2-40-574	Overload - AB - BSB 80	
2-40-566	Overload - AB - BSB 90	

Note: Contactor Overload depends on motor h.p. and voltage

Part No.	Pressuretrols	HP
4-40-050	Night Heating Pressuretrol Set Up	4-100
2-40-227	Pressuretrol L404A - 2-15 PSI	4-100
<a href="#">2-40-228</a>	Pressuretrol L404A - 5-50 PSI	4-100
<a href="#">2-40-229</a>	Pressuretrol L404A - 10-150 PSI	4-100
2-40-230	Pressuretrol L404A - 20-300 PSI	4-100
2-40-231	Pressuretrol L404C - 2-15 PSI	4-100
2-40-232	Pressuretrol L404C - 5-50 PSI	4-100
<a href="#">2-40-233</a>	Pressuretrol L404C - 10-150 PSI	4-100
2-40-234	Pressuretrol L404C - 20-300 PSI	4-100

Note: Correct pressuretrol is based on boiler trim pressure.

\*Standard on 60-100 HP; optional 4-50 HP.

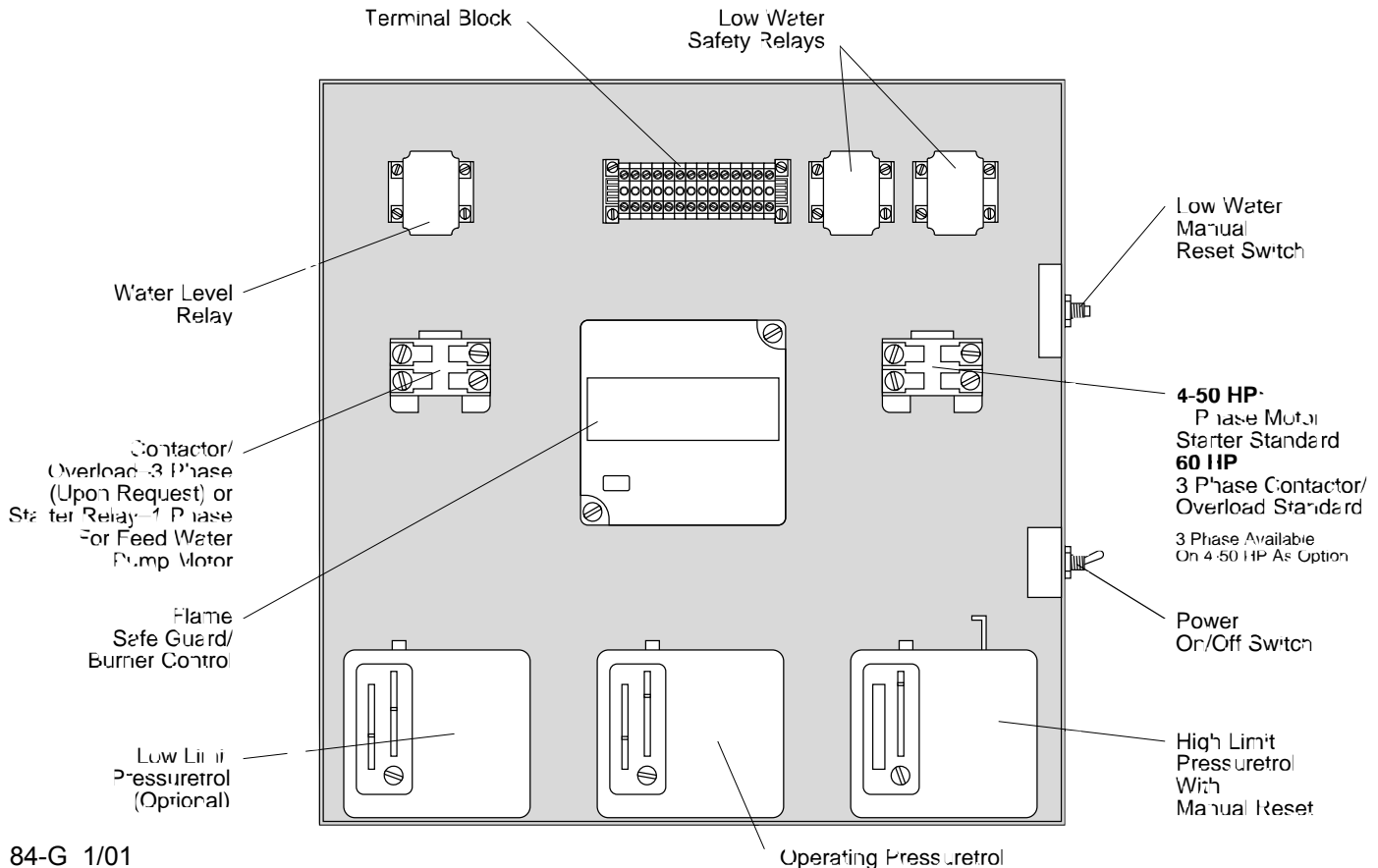

# Parts

## Water Column - Parts

Part No.	Water Column Bottle Casting (1)	HP
5-20-022	Water Column Bottle Casting	4-30
5-20-048	Water Column Bottle Casting	50-100

Part No.	Water Gauge Glass (2)	HP
2-12-017	9-1/4" Water Gauge Glass - Corning	4-100
2-12-065	8-5/8" Extra Heavy Gauge Glass	9.5

Part No.	Water Gauge Glass Trim	HP
2-30-149	Water Gauge Glass Valves w/Ball Checks (3)	4-100
2-30-155	Conbraco 250 w/Ball Check (3)	9.5
2-12-020	Brass Water Gauge Glass Gasket (4)	4-100
2-12-019	Rubber Water Gauge Glass Gasket (5)	4-100
2-35-514	Brass Packing Nut for Gauge Glass Valve (6)	4-100
2-30-330	Gauge Glass Protector Rods (7)	4-100
2-12-022	Lucite Gauge Glass Guard -9-1/4" Glass (8)	4-100
2-12-204	Lucite Gauge Glass Guard -8-5/8" Glass (8)	9.5

Part No.	Water Level Probes & Plugs	HP
2-20-010	*Pump Off Probe - 7-1/4" (9)	6-100
2-20-011	*Pump On Probe - 9-1/4" (10)	6-100
2-20-012	*Low Water Probe in Water Column-11-1/4" (11)	6-100
2-20-017	Low Water Probe in Boiler- 17-1/8" (12)	6-100
2-21-012	Probe Cover (13)	4-100
2-21-013	Probe Basket (14)	4-100
2-30-398	1/4" Ball Valve for Water Column (15)	4-100

\*For 4 HP boilers only, the water column probes are 2" shorter.

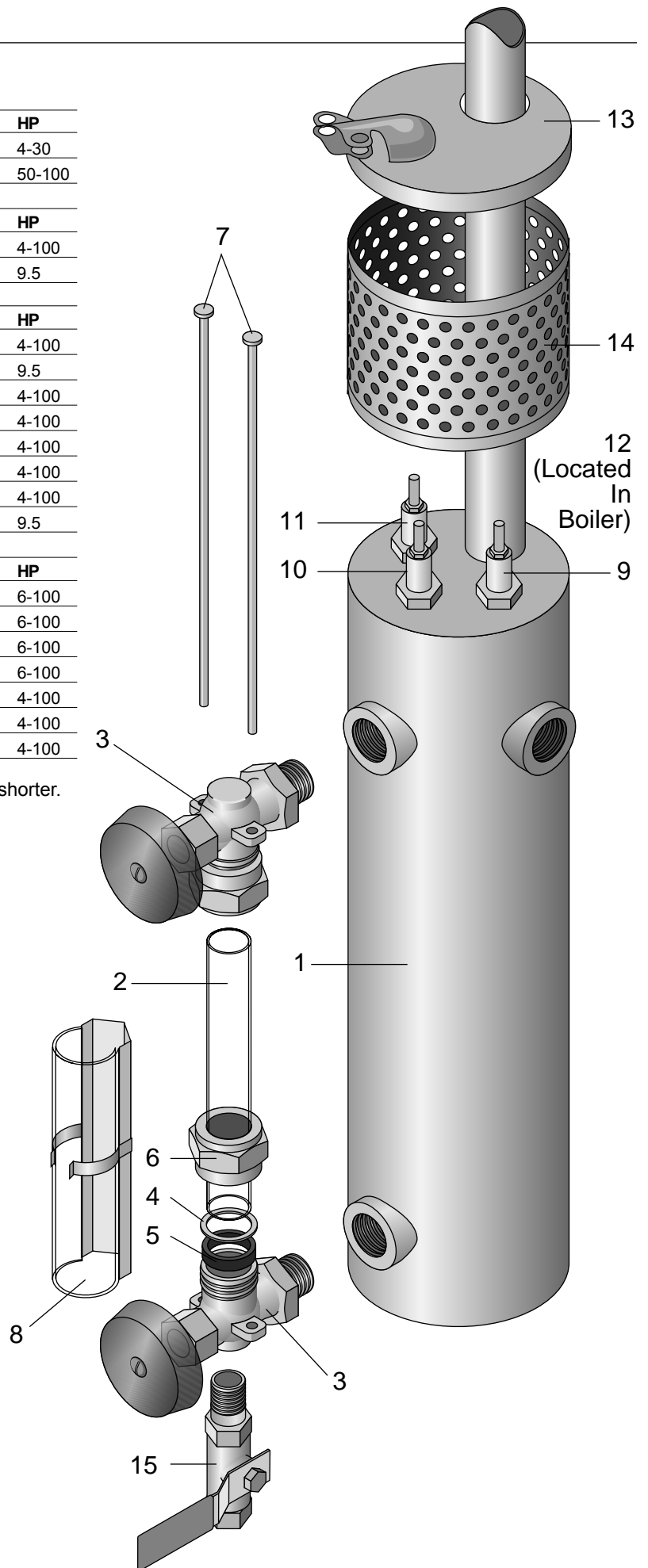

6



# Standard Warranty for Fulton Boilers

Warranty Valid for Models ICS, ICX, ICW, ICXW, VMP, VMPW, FB-A, FB-F, FB-L, FB-S, FB-W

---

## **Five (5) Year (60 Months) Material and Workmanship Warranty**

The pressure vessel is covered against defective material or workmanship for a period of five (5) years from the date of shipment from the factory. Fulton will repair or replace F.O.B. factory any part of the equipment, as defined above, provided this equipment has been installed, operated and maintained by the buyer in accordance with approved practices and recommendations made by Fulton. The commissioning agency must also successfully complete and return the equipment Installation and Operation Checklists to Fulton's Quality Assurance department. This warranty covers any failure caused defective material or workmanship; however, waterside corrosion or scaling is not covered. Therefore, it is imperative that the boiler water management and chemistry be maintained as outlined in the Installation and Operation Manual.

## **Parts Warranty**

Fulton will repair or replace F.O.B. factory any part of the equipment of our manufacture that is found to be defective in workmanship or material within one (1) year of shipment from the factory provided this equipment has been installed, operated and maintained by the buyer in accordance with approved practices and recommendations made by both Fulton and the component manufacturers and the commissioning agency has successfully completed and returned the equipment Installation and Operation Checklists to Fulton's Quality Assurance department.

## **General**

Fulton shall be notified in writing as soon as any defect becomes apparent. This warranty does not include freight, handling or labor charges of any kind.

These warranties are contingent upon the proper sizing, installation, operation and maintenance of the boiler and peripheral components and equipment. Warranties valid only if installed, operated, and maintained as outlined in the Fulton Installation and Operation Manual.

No Sales Manager or other representative of Fulton other than the Quality Manager or an officer of the company has warranty authority. Fulton will not pay any charges unless they were pre-approved, in writing, by the Fulton Quality Manager.

This warranty is exclusive and in lieu of all other warranties, expressed or implied, including but not limited to the implied warranties of merchantability and fitness for a particular purpose. Fulton shall in no event be liable for any consequential or incidental damages arising in any way, including but not limited to any loss of profits or business, even if the Fulton Companies has been advised of the possibility of such damages. Fulton's liability shall never exceed the amount paid for the original equipment found to be defective.

To activate the warranty for this product, the appropriate commissioning sheets must be completed and returned to the Fulton Quality Assurance department for review and approval.



9/9/09

# Extended Warranty for Fulton Skid Mounted Steam Boilers

Warranty Valid for Models ICS, ICX, VMP, FB-A, FB-F, FB-L

## Ten (10) Year Material and Workmanship Warranty

The pressure vessel is covered against defective material or workmanship for a period of ten (10) years from the date of shipment from the factory. Fulton will repair or replace at our option, F.O.B. factory any part of the equipment, as defined above, provided this equipment has been installed, operated and maintained in accordance with the Installation, Operation and Maintenance Manual. The commissioning agency must also successfully complete and return the equipment Installation and Operation Checklist to Fulton's Service Department. This warranty covers any failure caused by defective material or workmanship, however, waterside corrosion or scaling is not covered. Therefore, it is imperative that the boiler water management and chemistry be maintained as outlined in the Installation, Operation and Maintenance Manual.

The extended warranty is valid only for steam boilers that are purchased as part of a skid mounted boiler system. Generally, this system MUST include ALL of the following equipment in order for the warranty to apply.

1. Fulton boiler with model number as listed above.
2. Fulton DA or condensate return system with preheat kit.
3. Fulton blowdown tank/separator
4. Water softener
5. Chemical feed system
6. Automatic surface or bottom blowdown, which must operate to maintain TDS levels as specified in the Installation, Operation and Maintenance Manual.

Any deviation or additional equipment specified by Fulton Engineering must be used and maintained per the Installation, Operation and Maintenance Manual

There is a \$1,000 labor allowance for any failed pressure vessel that is covered under the above warranty.

## Parts Warranty

Fulton will repair or replace FOB factory any part of the equipment of our manufacture that is found to be defective in workmanship or material within twelve (12) months of shipment from the factory provided this equipment has been installed, operated and maintained by the buyer in accordance with approved practices and recommendations made by both Fulton and the component manufacturers.

## General

Fulton shall be notified in writing as soon as any defect becomes apparent. This warranty does not include freight, handling or labor charges of any kind.

No Sales Manager or other representative of Fulton other than the Quality Manager or an officer of the company has warranty authority. Fulton will not pay any charges unless they were pre-approved, in writing, by the Fulton Quality Manager.

This warranty is exclusive and in lieu of all other warranties, expressed or implied, including but not limited to the implied warranties of merchantability and fitness for a particular purpose. Fulton shall in no event be liable for any consequential or incidental damages arising in any way, including but not limited to any loss of profits or business, even if Fulton has been advised of the possibility of such damages. Fulton's liability shall never exceed the amount paid for the original equipment found to be defective.

## Conditions of Warranty

Warranties are only valid if the boiler is installed, operated and maintained as outlined in the Installation, Operation and Maintenance Manual. Fulton shall accept no responsibility if the equipment has been improperly installed, operated or maintained or if the buyer has permitted any unauthorized modification, adjustment, and/or repairs to the equipment. The use of replacement parts not manufactured or authorized by Fulton will void any warranty express or implied.

Warranty coverage for all components and equipment in said warranty are not valid unless the boiler is started up by a factory certified technician. The commissioning agency must successfully complete and return the equipment Installation and Operation Checklist to Fulton's Service department.

The boiler must be maintained in accordance with the product manual and annual combustion and maintenance reports must be produced for warranty consideration.

The warranty is valid for the original installation only in the U.S.A and Canada.



08/20/10



## Limited Warranty for IC-S Steam Boilers

Effective 12/30/2022

Provided the boiler is installed, commissioned, controlled, operated, and maintained in accordance with Fulton's Installation, Operation and Maintenance Manual, and the Fulton Authorized Representative or Fulton Factory Technician has successfully completed and returned the equipment Installation and Operation Checklists to the Fulton Quality department, Fulton provides the following limited warranty:

### **PRESSURE VESSEL WARRANTY**

The pressure vessel is warranted for five (5) years from the date of shipment from the factory against failures determined by Fulton to be the result of defective materials or workmanship. If so determined, Fulton will repair, replace, exchange or credit, at Fulton's sole discretion, the pressure vessel, F.C.A. factory. Waterside corrosion or scaling is not covered. Failures outside of the ASME pressure vessel boundary are not covered under this section.

### **PARTS WARRANTY**

Fulton will repair or replace F.C.A. factory any part of the equipment of our manufacture that is found to be defective in workmanship or material within eighteen (18) months of shipment from the factory or one (1) year from startup provided this equipment has been installed, operated, and maintained by the buyer in accordance with requirements in the manuals of Fulton and the component's manufacturer.

### **CONDITIONS OF WARRANTY**

The warranty is valid for the original installation and original owner only. Any modifications, adjustments, repairs, or replacement parts to the equipment not authorized by Fulton will void this warranty.

Fulton shall be notified in writing as soon as any defect or failure becomes apparent. These can be emailed to [warranty@fulton.com](mailto:warranty@fulton.com). Failure to do so may limit Fulton's obligations under this warranty or render the warranty invalid in whole or in part. No agent or representative of Fulton has authority to modify or alter the conditions of warranty. A formal Purchase Order is required prior to shipment of any replacement warranty item. This warranty does not include freight, handling, or labor charges.

To the extent not prohibited by law in the state, province, jurisdiction or country of purchase, this warranty and the remedies set forth are exclusive and in lieu of all other warranties, remedies, and conditions, whether oral, written, statutory, express, or implied, including but not limited to, the implied warranties of merchantability and fitness for a particular purpose. In no event or under any circumstances shall Fulton be liable for any consequential, incidental, special, punitive, or other indirect damages arising in any way including, but not limited to, loss of profits or business, even if Fulton has been advised of the possibility of such damages. Under no circumstances shall Fulton's liability exceed the amount paid to Fulton for the original equipment.

THIS LIMITED WARRANTY IS GOVERNED BY AND CONSTRUED UNDER THE LAWS OF THE STATE, COUNTRY, JURISDICTION, OR PROVINCE IN WHICH THE PRODUCT WAS ORIGINALLY SOLD BY FULTON. THE LIMITED WARRANTY TERMS CONTAINED IN THIS STATEMENT, EXCEPT TO THE EXTENT LAWFULLY PERMITTED, DO NOT EXCLUDE, RESTRICT, OR MODIFY BUT ARE IN ADDITION TO THE MANDATORY STATUTORY RIGHTS APPLICABLE TO THE SALE OF THIS PRODUCT. OUTSIDE THE UNITED STATES AND CANADA AND TO THE EXTENT SUCH WARRANTIES, TERMS AND CONDITIONS CANNOT BE DISCLAIMED AND ARE PERMITTED BY APPLICABLE LAW, FULTON LIMITS THE DURATION AND REMEDIES OF SUCH WARRANTIES AND CONDITIONS TO EIGHTEEN (18) MONTHS OF SHIPMENT FROM THE FACTORY OR ONE (1) YEAR FROM STARTUP, WHICHEVER COMES FIRST. THIS LIMITED WARRANTY GIVES THE PURCHASER SPECIFIC LEGAL RIGHTS, AND THE PURCHASER MAY HAVE OTHER LEGAL RIGHTS, WHICH MAY VARY BY STATE, COUNTRY, JURISDICTION, OR PROVINCE.

# 7

