



**THE
GAYLORD VENTILATOR
TECHNICAL MANUAL**

**FOR THE "CG3" SERIES
WATER-WASH VENTILATORS
WITH
MODEL C-6000 COMMAND CENTER**

GAYLORD INDUSTRIES

10900 S.W. AVERY STREET • TUALATIN, OREGON 97062-1149 U.S.A.
1-800-547-9696 • 503-691-2010 • FAX: 503-692-6048 • email: info@gaylordusa.com



*"Undisputed World Leader in
Engineered Systems for
Commercial Kitchens"™*

GAYLORD INDUSTRIES

10900 S.W. Avery Street • Tualatin, Oregon 97062-1149 U.S.A.

To Our Customers...

Congratulations on your recent purchase of a Gaylord kitchen exhaust hood system. We are proud to be able to provide you with a quality product that incorporates the latest engineering concepts and is a result of over 50 years of experience in the foodservice kitchen exhaust industry.

If you have other Gaylord equipment such as a Gaylord Utility Distribution System, Quencher Fire Protection System, or Roof Top Air Handling Equipment, etc., please refer to the corresponding supplementary equipment manuals.

If you have further questions, please visit our web site at: www.gaylordusa.com, or call us toll-free at 1-800-547-9696. We are more than happy to help.

Sincerely,

Gaylord Industries

STREET ADDRESS: 10900 S.W. Avery Street, Tualatin, Oregon 97062-8549 U.S.A.

PHONE: 503-691-2010 • 800-547-9696 • **FAX:** 503-692-6048 • **email:** gaylord@gaylordusa.com • www.gaylordusa.com

COMMERCIAL KITCHEN EXHAUST SYSTEMS • FIRE PROTECTION • UTILITY DISTRIBUTION • ROOF TOP UNITS • POLLUTION CONTROL

TABLE OF CONTENTS

"CG3" VENTILATOR DESCRIPTIONS	4-5
"CG3" SERIES PRINCIPLE OF OPERATION	6-9
DAILY OPERATION	10
PREVENTIVE MAINTENANCE	11
DETERGENT PUMP OPERATION	12
DETERGENT FOR THE WASH SYSTEM	13
MODEL C-6000 SERIES COMMAND CENTER - INSTRUCTIONS	14-17
ENGINEERING DATA	18-19
RP DEVICE INITIAL START UP	20
MEASURING INLET SLOT VELOCITY	21-23
OPTIONAL CONTINUOUS COLD WATER MIST	24
C-6000 MODEL IDENTIFICATION	25
TRUBLE-SHOOTING:	
SMOKE LOSS	26
GREASE EXTRACTION	26
EXHAUST FAN.....	27
WASH SYSTEM	27-28
FIRE CYCLE	29
BACKFLOW PREVENTERS	29-30
VACUUM BREAKER	29
RP DEVICE	30
DRAINS	30
MISCELLANEOUS	30
PLC STATUS LIGHT CHART	31
C-6000, C-6000-A AND C-6000-B TERMINAL VOLTAGES	32
PARTS LISTS:	
MODEL GPC-6000-VB SERIES CONTROL CABINET	33
MODEL GPC-6000 SERIES CONTROL CABINET	34
MODEL GPC-6000-S SERIES CONTROL CABINET	35
OPTIONAL CONTINUOUS COLD WATER MIST	36
MODEL C-6000 OR C-6000-A SERIES CONTROL	37
MODEL C-6000-B SERIES CONTROL	38
DAMPER CONTROL MOTOR AND CG3-FDL WIRING	39
DETERGENT PUMP	40
MISCELLANEOUS VENTILATOR PARTS	41
WIRING DIAGRAMS	42-49
STANDARD VENTILATOR MODELS	50
METRIC CONVERSION CHART	51
START-UP INSPECTION REPORT	52
LIMITED WARRANTY	Inside back cover

Patent Pending

© Copyright 2002, Gaylord Industries

ALL RIGHT RESERVED. NO PART OF THIS BOOK MAY BE REPRODUCED, STORED IN A RETRIEVAL SYSTEM, OR TRANSMITTED IN ANY FORM BY AN ELECTRONIC, MECHANICAL, PHOTOCOPYING, RECORDING MEANS OR OTHERWISE WITHOUT THE WRITTEN PERMISSION OF GAYLORD INDUSTRIES COPYRIGHT 2005.

The manufacturer reserves the right to modify the materials and specifications resulting from a continuing program of product improvement or the availability of new materials.

Additional Copies \$15.00

CG3 VENTILATOR DESCRIPTIONS

There are 5 different types of **CG3** "Classic Gaylord", water-wash ventilators. The differences involve the type and location of fire damper and whether the ventilator has a fire damper. The first part of the model number indicates the type of ventilator, see below:

Explanation of Prefixes:

- CG3 Water-wash ventilator with three-position, thermostatically activated (electric) damper at air inlet slot. **[With Damper motor and 1 or more Thermostat(s)]**
- CG3-FDL ... Water-wash ventilator with three-position, thermostatically activated (electric) damper at air inlet slot. A bracket (Fire Damper Lockout) has been added to prevent the damper from closing to the fire position. **[With Damper motor and 1 or more Thermostat(s)]**
- CG3-FDD ... Inlet damper is fixed, and there is a weighted fuse link activated fire damper located at the duct collar. **[No Damper motor, No Thermostats]**
- CG3-FDT ... Inlet damper is fixed, and there is a weighted fuse link activated fire damper located at the duct collar, and there is a single thermostat to activate the fire mode in the control cabinet and ventilator. **[No Belimo, One Thermostat]**
- CG3-ND Inlet damper is fixed. No Fire Damper at duct collar. A bracket (Fire Damper Lockout) has been added to show that the damper will not close to the fire position. **[No Damper motor, No Thermostats]**

Summary of CG3 Ventilators:

The CG3 and CG3-FDL are very similar. Both have a damper motor that closes the inlet damper during the wash mode and stays closed until the exhaust fan is started. Both have thermostats that can detect an "Internal Fire". The main difference is the CG3-FDL has a Fire Damper Lockout (FDL) bracket added that prevents the inlet damper from closing to the fire position, so it does NOT have a fire damper.

The CG3-FDD and CG3-FDT are similar to each other. Both have fixed inlet dampers and do not have damper motors. They both have fuse link activated fire dampers in the duct collar that will close when the temperature reaches 250°F. The CG3-FDT has an added thermostat that will detect an "Internal Fire" and activate the "Internal Fire Mode". The CG3-FDD does NOT have any thermostats.

The CG3-ND has a fixed inlet damper and does NOT have a fire damper.

CG3 VENTILATOR DESCRIPTIONS

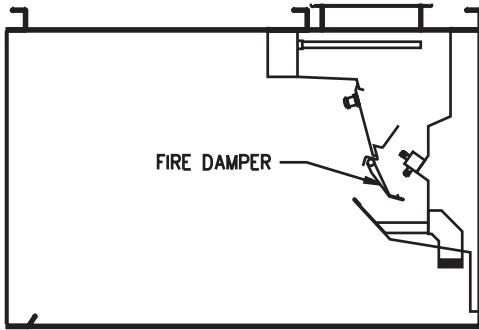

**CG3 SERIES
ELECTRIC INTERNAL DAMPER
[W/DAMPER MOTOR &
THERMOSTAT(S)]**

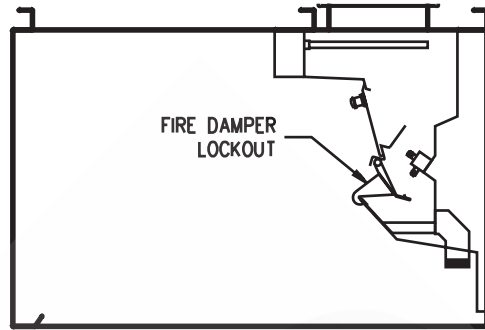

**CG3-FDL SERIES
FIRE DAMPER LOCKOUT
[W/DAMPER MOTOR &
THERMOSTAT(S)]**

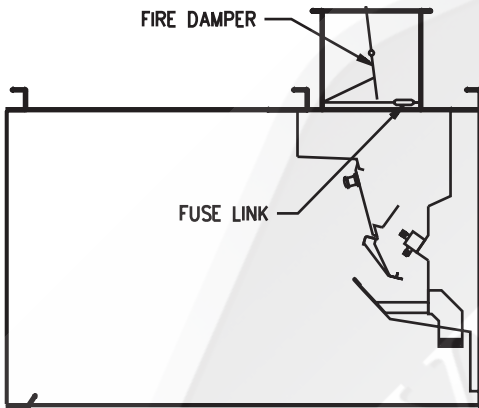

**CG3-FDD SERIES
FUSE LINK DUCT COLLAR DAMPER
[NO DAMPER MOTOR, NO
THERMOSTAT(S)]**

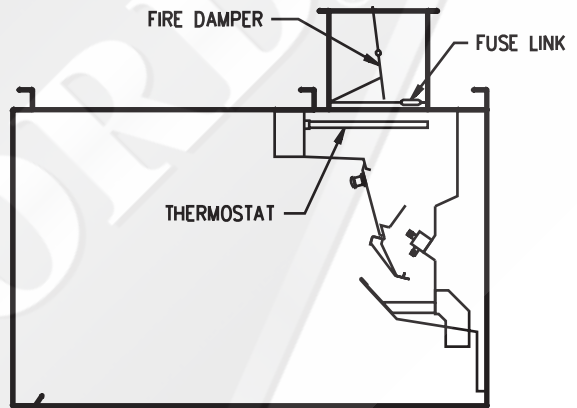

**CG3-FDT SERIES
FUSE LINK DUCT COLLAR DAMPER
[NO DAMPER MOTOR, ONE
THERMOSTAT]**

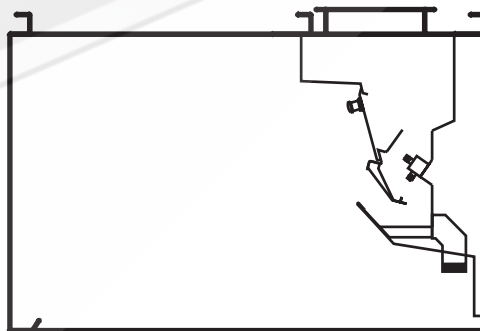

**CG3-ND SERIES
NO DAMPERS
[NO DAMPER MOTOR, NO
THERMOSTATS]**

"CG3" SERIES VENTILATOR PRINCIPLE OF OPERATION

GREASE EXTRACTION

The Gaylord "CG3" Series Ventilator extracts up to 95% of the grease, dust and lint particles from the airstream passing through it, when operated and maintained in accordance with design specifications.

The hot, contaminant-laden air rising from the cooking surface merges with the higher velocity air that wipes the front of the cooking equipment and extends, like an air blanket, from the front edge of the cooking equipment to the air inlet of the ventilator. As the air moves through the ventilator at a high speed, it is forced to make a series of turns around three baffles. As the high velocity air turns around each baffle, the heavier-than-air particles of grease, dust and lint are thrown out of the airstream by centrifugal force. The extracted grease, dust and lint are collected in the interior of the ventilator, remaining out of the airstream until removed daily by the wash cycle.

Baffle #1

This baffle, located at the air entrance of the ventilator, is a three position damper. Position 1 is the exhaust on mode as shown in Figure 1 below, position 2 is the wash mode, and position 3 is the fire mode. When the "Start Fan" button is pushed on the control cabinet, the damper opens to the exhaust mode (position 1) to become the preliminary grease

extraction baffle. There is a small sloped grease collecting gutter on the back side of the damper which drains off liquefied grease, preventing it from re-entraining into the airstream.

Baffle #2

This baffle is located on the interior back wall of the ventilator and is a stainless steel pipe, equipped with brass spray nozzles on 8" to 10" centers. (Refer to Figure 1) During the wash cycle, hot detergent water is released through the nozzles. If the ventilator's automatic fire control system is activated, fire smothering water spray is also released through the spray nozzles.

Baffle #3

This baffle is located on the back of the inspection doors. This baffle is also a grease collecting gutter, collecting grease, dust and lint extracted by the ventilator - preventing the contaminants from dropping back into the high velocity airstream.

NOTE: Some ventilators may be equipped with optional "Custom Air" baffles (shown dotted) which reduces the exhaust volume where the baffle occurs.

NOTE: Some ventilators may be equipped with optional continuous cold water mist. Refer to Page 24 for details.

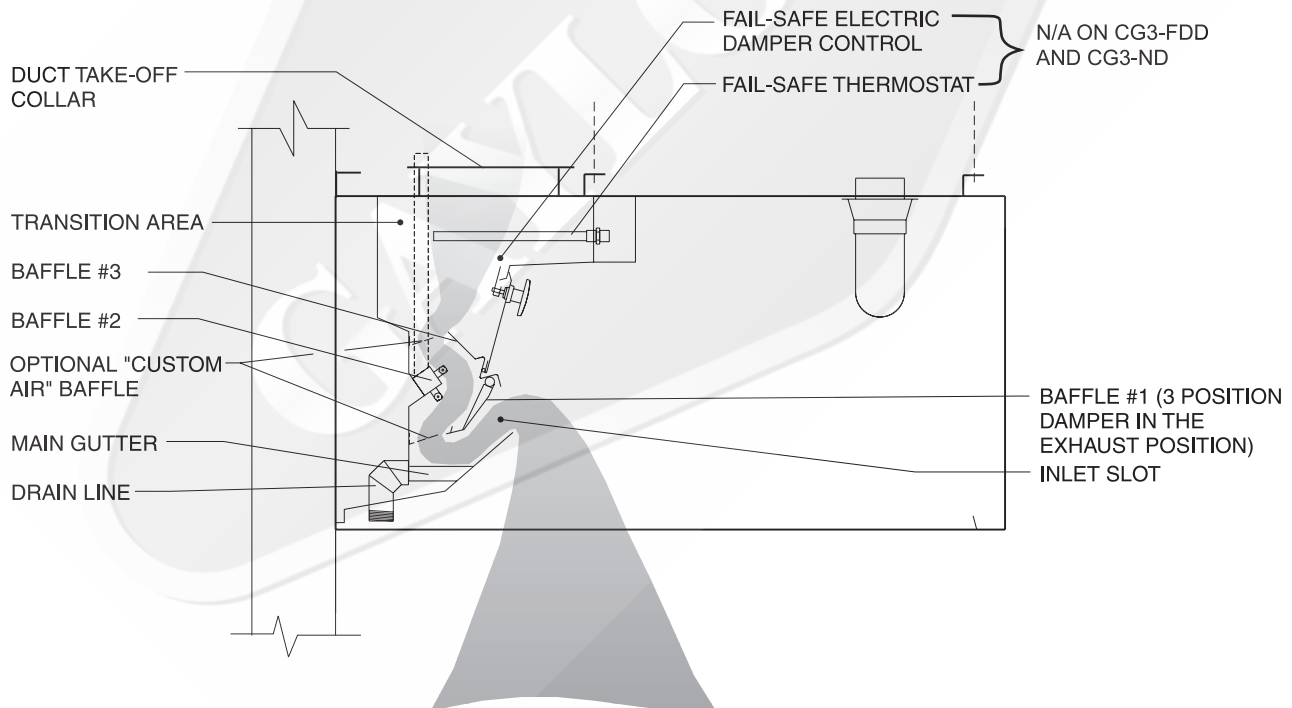

FIG. 1
GREASE EXTRACTION

"CG3" SERIES VENTILATOR PRINCIPLE OF OPERATION

WASHCYCLE

The wash cycle is activated each time the exhaust fan is shut off by pushing the **"Start Wash"** button on the Command Center or as programmed on the clock. When activated the exhaust and supply fans shut off, the damper control is energized and the damper begins closing forward to the wash position, and once closed the hot water wash sprays come on. The ventilator may be equipped with an optional second wash manifold as shown in Figure 3 and is indicated in the model number, stamped on the ventilator nameplate, by the suffix "DW". This is typically used when extra heavy duty cooking equipment is under the ventilator.

This hot detergent water washes the day's grease, dust and lint accumulation from the interior of the ventilator flushing it down to the main gutter which slopes to a pre-flushed drain which leads to the building drain system. Spray nozzles are located on 8" to 10" centers on the wash manifold mounted on the interior back wall of the ventilator. At the end of the wash cycle, the water automatically shuts off, and the interior of the ventilator is clean - ready for the next day's operations. The damper remains in the wash position until the exhaust fan is restarted. This is to prevent conditioned air from going up the exhaust system during off hours.

The length of the wash cycle may be set between 3 minutes and 9 minutes. The length of time is dependent upon the type of cooking equipment being used. Typical settings are 3 minutes for light-duty equipment, 5 minutes for medium-duty equipment, and 9 minutes for heavy-duty equipment. However, adequate cleaning is dependent upon water pressure, water temperature, daily grease accumulation, the length of the wash cycle, frequency of wash cycle and the type of detergent being used. It may be necessary to increase the wash time to achieve proper cleaning. Refer to page 15 for details on setting the wash time.



FIG. 2
VENTILATOR CONTROL CABINET
MODEL GPC-6000 SERIES

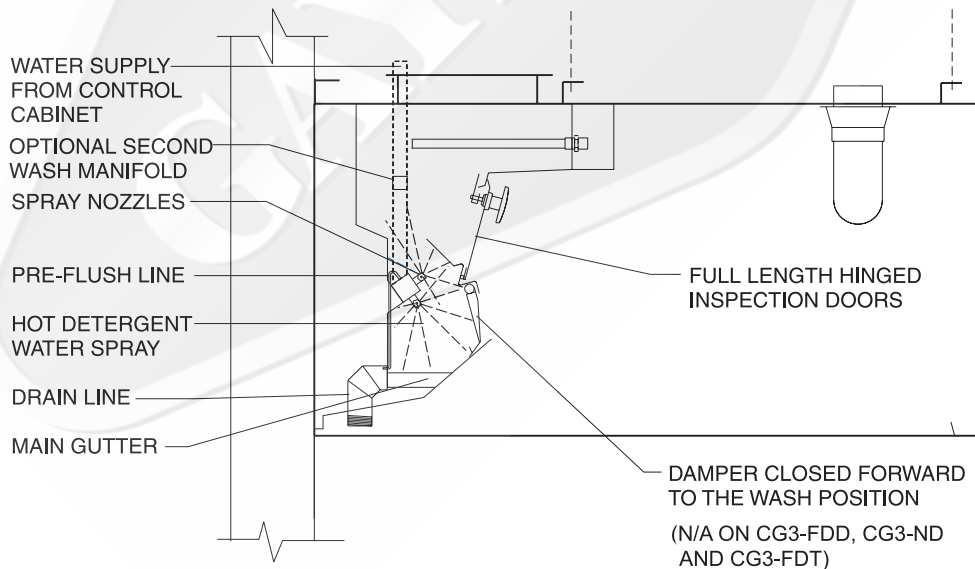

FIG. 3
WASH CYCLE

"CG3" SERIES VENTILATOR PRINCIPLE OF OPERATION

INTERNAL FIRE MODE — For CG3 and CG3-FDT only!

Automatic internal fire protection is accomplished by the action of the thermostat(s), which are located at the point where the ductwork joins the ventilator. When the temperature of the conveying airstream, which must pass over the thermostats, reaches 250°F, the system is activated, and the following occurs:

1. The damper begins closing back to the fire position, position 3 as shown in Fig.4—stopping the combustion-supporting, natural draft through the ventilator and creating a fire barrier to contain the fire in the kitchen. (N/A on CG3-FDT)
2. The exhaust fan serving the ventilator is shut off. The supply fan is also shut off.
3. Fire-smothering water spray is released into the interior of the ventilator through the spray nozzles.
4. The digital display reads "Fire In Hood, Fan Off, Wash On" for approximately 5 seconds.
5. Then the digital display reads "Fire In Hood, Damper Closing" for approximately 5 seconds.
6. Then the digital display reads "Fire In Hood, Notify Fire Department". This display stays on until the thermostat cools down below 250°F.

7. A red light on the Command Center illuminates.
8. If the Command Center is intertied with a building alarm or monitoring system, a fire signal would be sent to that system.
9. Upon cooling of the thermostat below 250°F, the Cool Down Cycle starts. The water continues to spray during the Cool Down Cycle (2 minutes). The damper moves to the exhaust position. (N/A on CG3-FDT)
10. While in the cool down cycle the digital display reads "Cool Down Cycle, xxx sec. to end". xxx is the countdown in seconds until the wash turns off. The damper moves to the exhaust position.
11. At the end of the cool down cycle the wash turns off and the digital display reads "Fan Off 12:00 (actual time), Start Fan>F1". The damper closes to the wash position. (N/A on CG3-FDT)

NOTE: The water may be shut off prior to the end of the 2 minute cool down cycle by pushing the "Exit" button on the C-6000 Command Center. After the water has shut off, the damper remains in the wash position until the "Start Fan" button is pushed.

CAUTION:

In case of severe fire the thermostats located in the plenum will activate. As a precautionary measure, it is recommended that the thermostats be replaced.

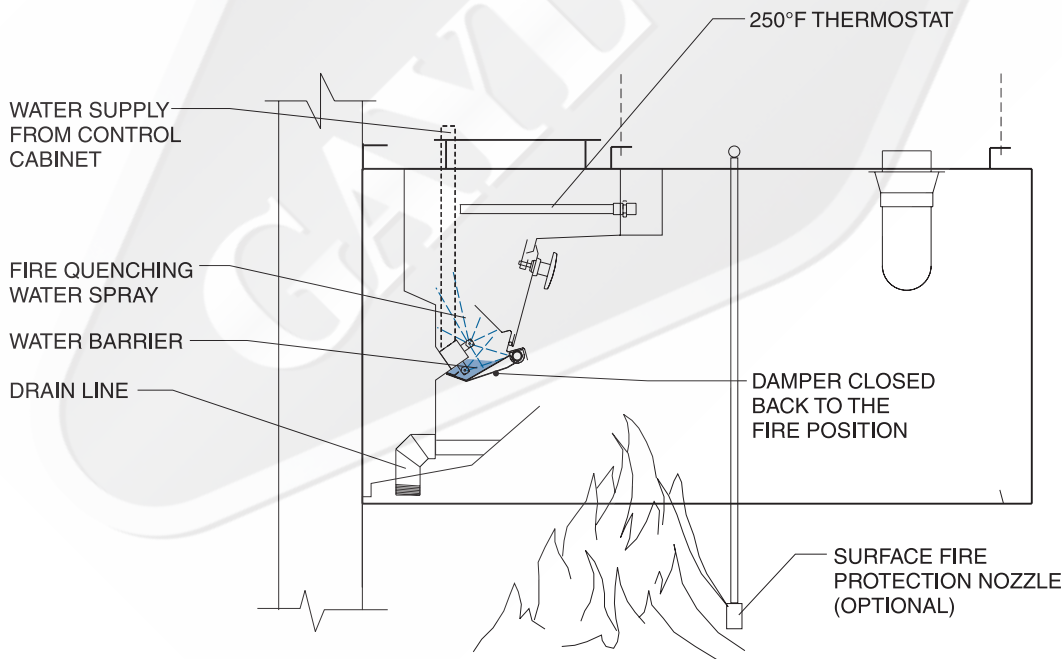

FIG. 4
FIRE CYCLE

"CG3" SERIES VENTILATOR PRINCIPLE OF OPERATION

EXTERNAL FIRE MODE

An External Fire Mode is activated by the Ventilator's Fire Suppression (Duct, Plenum, Surface/Appliance) system's microswitch or contacts and/or an optional break glass fire switch (see Figure 5). Terminals 4 & FS are used for the External Fire Mode, refer to wiring diagram for details. The break glass fire switch, if used, would normally be located at the exit of the kitchen. When the External Fire Mode is activated, the following occurs:

1. The Exhaust Fan comes on immediately if it was off to help remove smoke, heat, etc.
2. The Supply Fan shuts off immediately.
3. The digital display reads "Ext.FireActive" and alternates between "Reset FireSwitch" and "Fan On, Wash On".
4. A red light on the Command Center flashes.
5. After a 60-second delay, a fire smothering water spray is released into the interior of the ventilator through the spray nozzles. The 60-second delay allows the ventilator's fire suppression system time to put out the fire, before starting the water spray.

If the fire intensifies and the thermostat reaches 250°F, the fire damper would then close and the exhaust fan would shut off. See Internal Fire Mode.

To resume normal operations, open the fire switch and flip the toggle switch to the position marked "normal". Replace the glass rod and close the cover. Push either the "Start Fan" or "Start Wash" button.

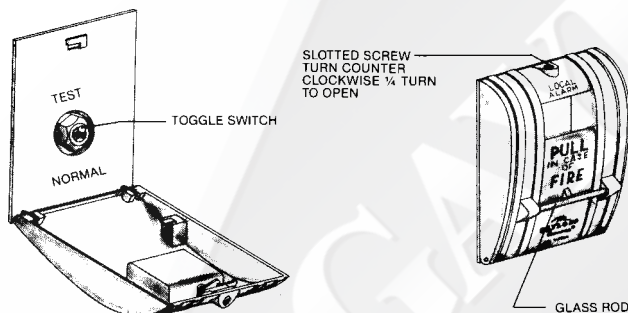

FIG. 5
BREAK GLASS FIRE SWITCH
C-1357A SERIES

INTERNAL & EXTERNAL FIRE MODES AT THE SAME TIME

It is possible that both the Internal and External Fire modes can be activated at the same time. If this occurs, the Internal Fire Mode will override the External Fire mode until the thermostat(s) cool below 250°F. At this point the Cool Down Cycle will start counting down for 2 minutes. After the Cool Down Cycle, the External Fire mode will start.

Special Note: If the control is in the Cool Down Cycle when the External Fire mode is activated, the Cool Down Cycle will finish counting down for 2 minutes, before switching to the External Fire Mode.

Summary of Both Fire Modes at the Same Time

1. Internal Fire Mode (until thermostat temperature drops below 250°F)
2. Cool Down Cycle (for 2 minutes)
3. External Fire Mode (until the External Fire Switch is reset)

TESTING INTERNAL FIRE MODE – FOR CG3 AND CG3-FDT ONLY!

The internal fire protection system may be tested periodically by pushing and holding for 20 seconds, the "Fire Test Switch" located inside the electrical compartment of the control cabinet. Pushing this switch duplicates thermostatic action. **CAUTION:** Before pushing the "Fire Test Switch", check to see if the internal fire protection system is tied to the building alarm system.

TO RESUME NORMAL OPERATION

1. To discontinue the 2 minute cool down cycle at any point during the cycle, push the "Exit" F5 button on the C-6000 Command Center.
2. Push the "Start Fan" F1 button on the Command Center.

SURFACE FIRE PROTECTION

The National Fire Protection Association, NFPA-96 document requires fire extinguishing equipment over all grease producing cooking equipment such as griddles, ranges, fryers, broilers, and woks. In addition, the system must protect the interior of the ventilator and the exhaust duct.

The most common fire system is either a wet chemical type or the Gaylord Quencher water spray system. In the event of a fire this system would normally be activated and discharged prior to the ventilator's internal fire protection. If the fire is unusually severe or the surface fire protection system malfunctions, the ventilator's internal fire protection system would activate, thus providing a second level of defense. These systems may be intertied with the ventilator control cabinet to activate the External Fire Mode.

FIRE MODE SUMMARY:

Note: The Damper Position does not apply to CG3-FDL, CG3-FDD, or CG3-ND

	INTERNAL FIRE	COOL DOWN CYCLE (for Internal Fire Mode only!)	EXTERNAL FIRE
Exhaust Fan	OFF	OFF	ON
Supply Fan	OFF	OFF	OFF
Damper Position	FIRE	EXHAUST	EXHAUST
Water Spray	ON	ON	ON

DAILY OPERATION

All functions of the ventilator, such as starting the exhaust fan, starting the wash cycle, etc., are controlled by the Command Center located on the control cabinet. Refer to Pages 14 through 17 for detailed instructions on the operation of the Command Center.

COMMAND CENTER
MODEL C-6000 SERIES



FIG. 6
VENTILATOR CONTROL CABINET
MODEL GPC-6000 SERIES

Starting the Exhaust Fan

To start the exhaust fan push the “**Start Fan**” button on the Command Center. If the Command Center is programmed to start the fan automatically, then the start button does not need to be pushed. It is important to start the exhaust fan before turning on the cooking equipment.

When the exhaust fan is activated the following occurs:

1. The damper begins opening to the exhaust position. (N/A on CG3-FDD and CG3-ND)
2. A green light on the Command Center illuminates.
3. The supply fan comes on.
4. The digital display reads "Starting Fan & Damper Opening" for approximately 5 seconds. Then the digital display reads "Starting Fan, xx Seconds to Fan On". xx is the countdown in seconds until the exhaust fan comes on.
5. After the damper fully opens (elapsed time approximately 45 seconds) the exhaust fan comes on.
6. The digital display then reads "Fan On 12:00" (current time) and "Start Wash> F2".

Stopping the Exhaust Fan and Starting the Wash Cycle

CAUTION: *The cooking equipment must be shut off prior to shutting off the exhaust fan. Failure to do this will cause excessive heat buildup and could cause the surface fire protection system to discharge.*

To start the wash cycle push the “**Start Wash**” button on the Command Center. If the Command Center is programmed to start the wash automatically, then the start button does not need to be pushed. When the wash cycle is activated the following occurs:

1. The exhaust and supply fans shut off.

2. The damper begins closing forward to the wash position. (See Figure 3, page 7). This action takes approximately 45 seconds. (N/A on CG3-FDD and CG3-ND)
3. The digital display reads "Starting Wash, Damper Closing" for approximately 5 seconds, then the digital display reads "Starting Wash, Wash On in xx seconds". xx is the countdown in seconds to until the wash starts.
4. After the damper closes to the wash position, the hot, detergent injected, water sprays come on to wash away the grease collected during the days operation. The wash cycle stays on for the length of time programmed in the Command Center. The length of the wash cycle may be set between 3 minutes and 9 minutes. Typical settings are 3 minutes for light-duty equipment, 5 minutes for medium-duty equipment and 9 minutes for heavy-duty equipment. Refer to page 15 for details on setting the wash time.
5. During the wash cycle, the digital display reads "Wash On, Wash #1 xxx seconds". xxx is the countdown in seconds until the wash system shuts off.
6. Upon completion of the wash cycle, the damper stays in the closed wash position until the exhaust fan is re-started. This is to prevent conditioned air from going up the exhaust stack during off hours.(N/A on CG3-FDD and CG3-ND)
7. The digital display now reads "Fan Off 12:00" (current time) and Start Fan>F1.

After the wash cycle is completed, wipe the exposed front surface of the damper at the air inlet slot, as well as other exposed exterior surfaces. (Refer to Figure 7, Page 11).

In very heavy cooking operations it may be necessary to wash the ventilator(s) more than once a day. This can be done manually by pushing the “**Start Wash**” button

NOTE: For proper operation of the wash system there must be adequate water pressure and temperature. There is a pressure/temperature gauge inside the control cabinet.

Water Pressure 40 psi min. - 80 psi max.

Water temperature 140°F min. - 180°F max.

NOTE: Some control cabinets are equipped with a low detergent switch. If so equipped, the green light will flash if the detergent tank is empty or if the detergent pump is malfunctioning and detergent is not pumping. The digital display reads "Low Detergent" and the text alternates from "Fill Tank" and "Check Pump". If the detergent tank is filled with water the detergent switch will activate as if there is no detergent.

NOTE: The ventilator wash system is designed to remove daily accumulations of grease within the extraction chamber. If the ventilator is not washed a minimum of once during a cooking day, a grease buildup could accumulate which the wash system cannot remove. If this occurs, it is recommended that the ventilator be put through several wash cycles by pushing the “**Start Wash**” button on the Command Center. If this does not remove the grease, it will be necessary to remove the grease manually by using a scraping tool, such as a putty knife, or retain the services of a commercial hood cleaning service to steam clean or pressure wash the system.

WARNING: *Some commercial hood cleaning services blow a fire retardant chemical into hood and duct systems. Fire retardant chemicals should never be applied to any portion of The Gaylord Ventilator. If retardant is applied to the ventilator, it must be removed.*

PREVENTIVE MAINTENANCE

The following should be checked periodically in order to keep The Gaylord Ventilator operating at design efficiency:

Weekly

1. The detergent tank should be checked at least weekly and kept full with a recommended detergent. (Refer to Page 13)

Monthly

1. The detergent system fittings should be checked at least monthly. This is an airtight system and fittings should be tight. (For complete details refer to the Detergent Pump section on Page 12.)
2. At least monthly, at the conclusion of a wash cycle, open the inspection doors of the ventilator and check to ensure that the interior has been cleaned of grease, dust, and lint. (Refer to Figure 7) If overall cleaning appears to be inadequate, refer to "Trouble-Shooting of the Wash System", Page 27.
3. The main grease gutter of the ventilator should be checked at least monthly to remove any foreign material such as paper towels, order chits, etc.

Every Six Months

1. Exhaust fan(s) should be checked every six months for belt tightness, belt alignment, and lubrication of necessary moving parts.

NOTE: A blue lithium based grease is best suited for high heat and speed bearing lubrication.

2. Check for proper velocity at air inlet slot. Refer to Pages 21 through 23 for method of checking velocity.
3. Test the "Internal Fire Mode" to check for proper damper closure. Refer to Page 9 for instructions.
4. Detergent tank and foot valve should be cleaned every six months.

INSPECTION AND CLEANING REQUIREMENTS

NFPA-96 (Standard for Ventilation Control and Fire Protection of Commercial Cooking Operations) require that hoods, ducts and exhaust fans be inspected by a properly trained, qualified and certified company or person(s) in accordance with the following table.

Upon inspection, if found to be contaminated with deposits from grease-laden vapors, the entire exhaust system shall be cleaned by a properly trained, qualified, and certified company or person(s) acceptable to the authority having jurisdiction in accordance.

When a vent cleaning service is used, a certificate showing date of inspection or cleaning shall be maintained on the premises. After cleaning is completed, the vent cleaning contractor shall place or display within the kitchen area a label indicating the date cleaned and the name of the servicing company. It shall also indicate areas not cleaned.

EXHAUST SYSTEM INSPECTION SCHEDULE	
Systems serving solid fuel cooking operations	Monthly
Systems serving high-volume cooking operations such as 24-hour cooking, charbroiling or wok cooking	Quarterly
Systems serving moderate-volume cooking operations	Semi-annually
Systems serving low-volume cooking operations, such as churches, day camps, seasonal businesses, or senior centers	Annually

Factory trained service agencies are certified by Gaylord Industries, Inc. to perform these inspections. For the name and phone number of your nearest agent visit our web site at www.gaylordusa.com, email at info@gaylordusa.com, or call 1-800-547-9696.

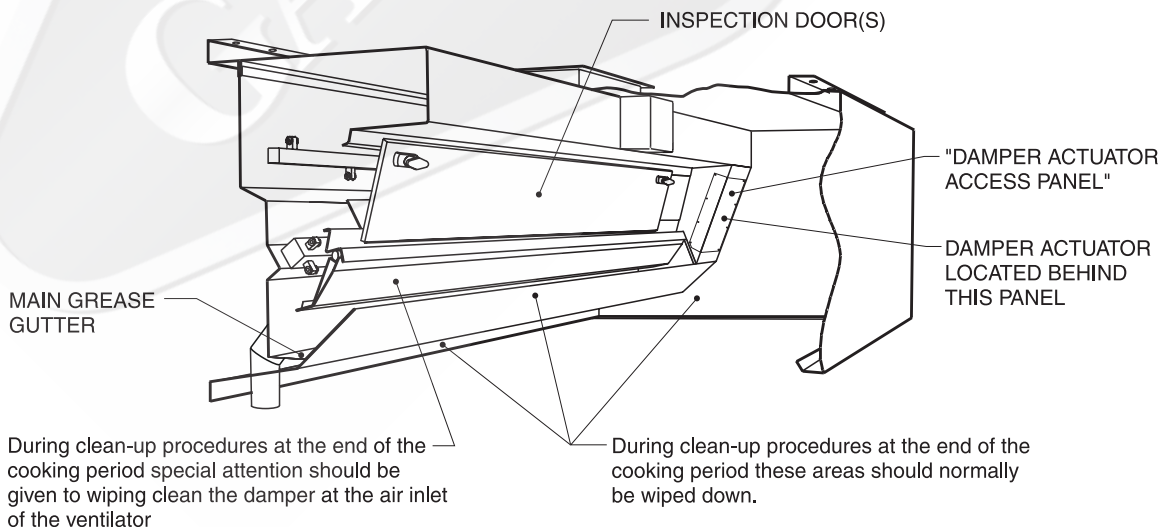

FIG. 7

DETERGENT PUMP OPERATION

The Gaylord Ventilator detergent pump is an integral part of the wash-down system of The Gaylord Ventilator. The pump is located within the control cabinet unless otherwise specified. (Refer to schematics on Pages 33 through 35.)

OPERATION

The detergent pump is started when the wash cycle begins. The pump draws detergent up from the detergent tank, pushing it through the copper tubing and into the hot water line serving the ventilator.

NOTE: Some control cabinets are equipped with a low detergent switch. If so equipped, the green light will flash if the detergent tank is empty or if the detergent pump is malfunctioning and detergent is not pumping. The digital display reads "Low Detergent" and the text alternates from "Fill Tank" and "Check Pump". If the detergent tank is filled with water the detergent switch will activate as if there is no detergent.

Initial Operation

To prime and operate the pump for the first time, it is recommended that water be used instead of detergent to prevent detergent from spilling in case of leaks at the system's fittings.

Priming The Pump

The detergent pump is self-priming. Push the pump test switch, located on the junction box of the motor, and hold down until liquid climbs up the vinyl tubing and fills the pump head. The pump will be operating properly when both upper and lower poppet checks can be seen moving up and down slightly. If the pump does not self-prime, an air lock may have developed within the pump head and the following action should be taken:

1. Hold down pump test switch and loosen top cap slightly to allow air to be pushed out. Repeat as necessary until liquid climbs up tube and fills pump head.

Note: Do not overly tighten cap or damage to the pump head will occur.

2. If the pump still does not work properly, check the following:
 - A. Foot valve should be clean and immersed in the liquid.
 - B. Check all fittings to ensure an airtight system.
 - C. Poppet checks within the foot valve, pump head and brass check valve should be clean and operating freely.
 - D. Detergent lines should be free and clear.

DETERGENT FLOW

Detergent flow is initially factory set according to the pipe size of the control cabinet (refer to chart). Generally, the factory setting will be sufficient to provide adequate cleaning of the ventilator. However, adequate cleaning is dependent upon a number of factors:

1. Temperature of hot water
2. Water pressure
3. Daily grease accumulation
4. Wash cycle time
5. Frequency of wash cycle
6. Type of detergent

Depending upon these factors, it may be necessary to adjust the detergent flow. Adjustment may be accomplished by changing the cam to a different size. To change the cam:

1. Loosen Allen set screw on brass cam.
2. Remove cam and replace with next size as required.
3. Cam #1 minimum setting. Cam #4 maximum setting.

NOTE: Cams are available from Gaylord Industries or your Gaylord Certified Service Agency.

PREVENTIVE MAINTENANCE

As with any piece of fine equipment, a reasonable amount of care must be taken to keep it in good working order:

1. Caution should be taken not to spill detergent on the exterior of the pump.
2. A periodic check should be made of all fittings to guarantee their tightness.

NOTE: The detergent pump motor has sealed bearings and will not require lubrication.

DETERGENT CONSUMPTION CHART
(Imperial)

Control Cabinet Pipe Size	Factory Cam Setting	Oz. Per Min. at 40 PSI Water Pressure	WASH CYCLE LENGTH					
			3 Minutes		5 Minutes		9 Minutes	
			Oz. Per Day	Gal. Per Mo.	Oz. Per Day	Gal. Per Mo.	Oz. Per Day	Gal. Per Mo.
1/2"	#1	3.2	9.6	2.1	16.1	3.5	22.5	4.9
3/4"	#2	5.1	15.6	3.4	26.1	5.7	36.5	7.9
1"	#3	6.0	17.8	3.9	29.6	6.5	41.4	9.1
1 1/4" & 1 1/2"	#4	6.3	18.8	4.1	31.3	6.8	43.8	9.6

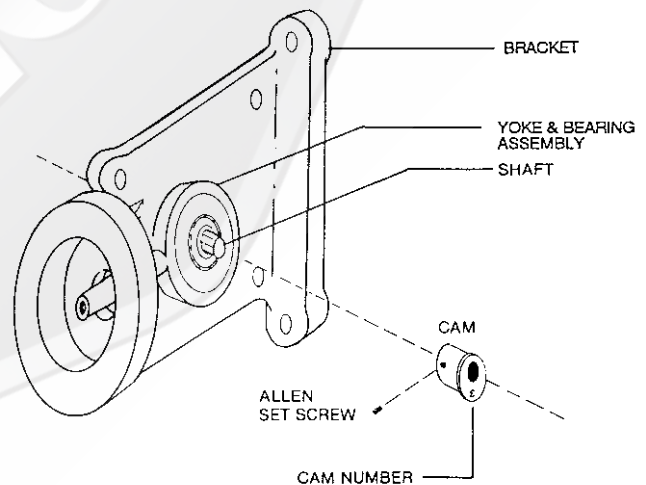

FIG. 8

DETERGENT FOR THE WASH SYSTEM

FORMULA G-510 is the only cleaner recommended by Gaylord Industries for use in the washdown system of The Gaylord Ventilator. FORMULA G-510 is a concentrated colloid cleaner specially formulated to remove the daily accumulation of grease inside The Gaylord Ventilator without damaging the rubber and synthetic parts of the detergent pumping system. FORMULA G-510 is biodegradable, safe for kitchen personnel, and has a variety of uses.

DILUTION OF FORMULA G-510 FOR VENTILATOR CLEANING

Normal Cleaning

For ventilators covering cooking equipment such as broilers, griddles, fryers, or any other heavy grease producing equipment, fill the detergent tank with full strength FORMULA G-510.

Light-Duty Cleaning

For ventilators covering light grease producing equipment such as ovens, kettles, steamers and ranges, fill the detergent tank with a mixture of one part FORMULA G-510 to one part water.

Cleaning the Ventilator Exterior

Mix one part FORMULA G-510 to twenty parts water in hand spray bottle. Spray on and wipe off. **NOTE:** Once a day, this same solution should be used to clean the front of the fire damper and main grease extracting baffle.

FOR OTHER CLEANING JOBS

The colloidal action of FORMULA G-510 makes it a cleaner especially well-suited for use in kitchens. The colloids break up dirt and grease into millions of tiny particles that constantly repel each other. These particles cannot recombine or re-deposit on a surface and are, therefore, easily washed away. FORMULA G-510 is biodegradable and contains no harsh chemicals, yet offers outstanding performance on the toughest cleaning jobs.

Use a mixture of one part FORMULA G-510 to twenty parts water for:

VINYL/PLASTIC/WALLS...Removes dirt, grease, food deposits and fingerprints.

REFRIGERATORS...Removes dirt, spilled milk, blood, mildew and objectionable odors.

RESTROOMS...Add a disinfectant to clean all fixtures, walls, floors, etc.

Use a mixture of one part FORMULA G-510 to five parts water for extremely heavy grease build-up, such as on the floor and on equipment around deep-fryers. Spray on and rinse or wipe off. For extremely soiled areas, gentle agitation, followed by a soaking period, will result in more thorough cleaning.

DON'T be afraid to experiment with FORMULA G-510 because it contains no phosphates, nitrates, enzymes, sulfates, sulfonates or silicates.

LIMITED WARRANTY

G-510 CHEMICAL DIVISION warrants that FORMULA G-510 will not cause cleansing agent damage to the rubber and synthetic parts of the injection pump ("O" rings, diaphragms, washers, tubing, and other such parts) used with The Gaylord Ventilator, Heat Reclaim Unit, or Pollution Control Equipment. G-510 CHEMICAL DIVISION'S obligation under this warranty and any warranties implied by law shall be limited to repairing or replacing, at its option, any of said parts which G-510 CHEMICAL DIVISION'S examination shall disclose to its satisfaction to have been damaged by the use of FORMULA G-510 for the life of the detergent pumping system. This warranty shall not cover damages caused by any other detergent. The use of any other detergent shall void this warranty.

All repairs and replacement parts under this warranty shall be F.O.B. G-510 CHEMICAL DIVISION'S factory. The owner shall pay the necessary freight and delivery charges; also removal and installation costs. Any federal, state or local taxes are also extra. Requests for repairs or replacement parts should be made to 20/10 Products Inc., PO Box 7609, Salem, OR 97303.

This is the sole warranty with respect to FORMULA G-510. G-510 CHEMICAL DIVISION MAKES NO OTHER WARRANTY OF ANY KIND WHATSOEVER, EXPRESSED OR IMPLIED, AND ALL IMPLIED WARRANTIES OF MERCHANTABILITY AND FITNESS FOR A PARTICULAR PURPOSE WHICH EXCEED THE AFORESAID OBLIGATION ARE HEREBY DISCLAIMED AND EXCLUDED FROM THIS AGREEMENT. G-510 CHEMICAL DIVISION SHALL NOT BE RESPONSIBLE FOR INCIDENTAL OR CONSEQUENTIAL DAMAGES RESULTING FROM A BREACH OF THIS WARRANTY.

IMPORTANT

If a cleansing agent other than FORMULA G-510 is used with The Gaylord Ventilator injection pump, it is recommended that a warranty similar to the above be obtained from the manufacturer of said product.

For name and address of the nearest FORMULA G-510 distributor contact:

20/10 Products Inc.
P.O. Box 7609
Salem, OR 97303
Phone: 800-286-2010
FAX: 503-363-4296
E-Mail: twentyten@juno.com

MODEL C-6000 SERIES COMMAND CENTER - INSTRUCTIONS

General Description:

The C-6000 Command Center is designed to start and stop the exhaust fan and wash up to 5 groups of ventilators in sequence with a delay period between each group. A sequence wash may be necessary if the building's hot water system is not capable of supplying the required volume of water at one given time.

The exhaust fan and wash sequence may be started **Manually** by pushing the "Start Fan" or "Start Wash" buttons, or may be programmed for **Automatic** operation.

Programmed operations may include:

1. Starting the exhaust fan once within a 24-hour period.
2. Stopping the exhaust fan and starting the wash cycle sequence once within a 24-hour period

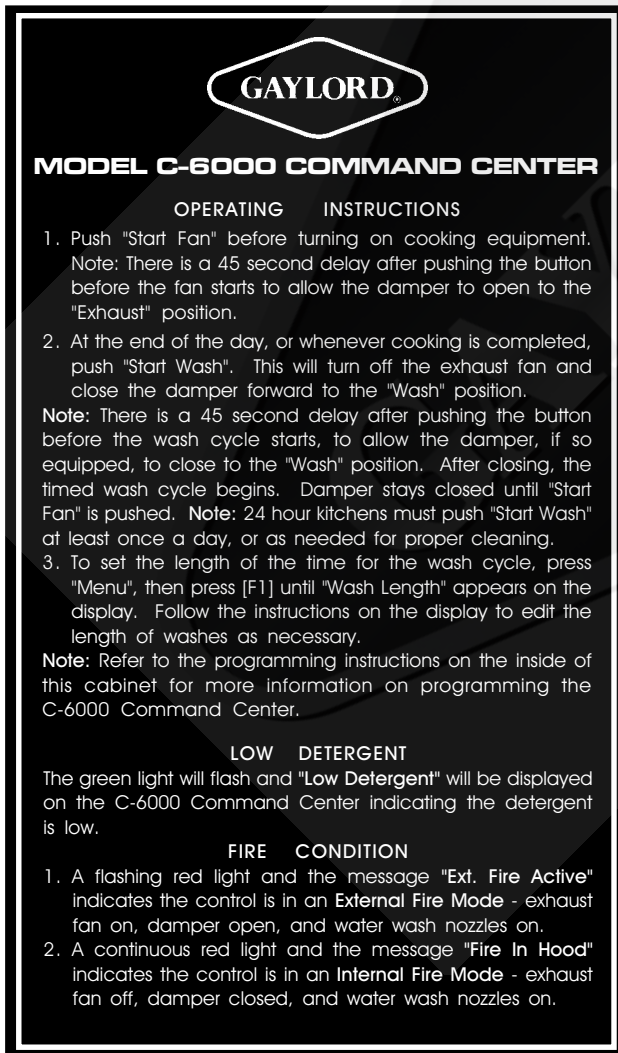
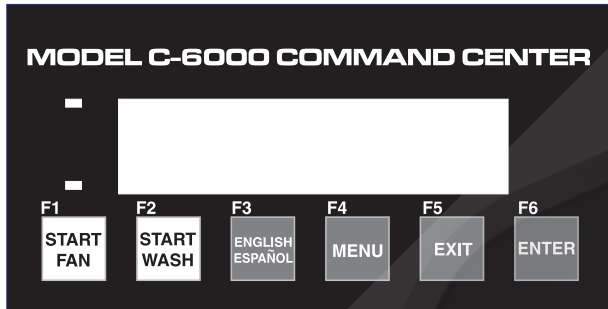

FIGURE 9
C-6000 COMMAND CENTER

3. Programming the length of the wash cycles and delay periods between the wash cycles. The maximum length of a wash cycle is 9 minutes. The maximum length of the delay period is 99 minutes.
4. Skipping a day so the exhaust fan and wash cycle do not operate for holidays or specific days within a 7-day week when the kitchen is not operating.

The C-6000 Command Center provides information and programming for various functions by accessing nine different menu categories. An overview of the nine menu items are as follows:

1. **Service** - Displays Gaylord's website address: gaylordusa.com
2. **Detergent** - Displays Toll-Free Number to order detergent: 800-286-2010
3. **Wash Length** - Sets length of each wash cycle from 3 to 9 minutes
4. **Delay Time** (for sequence wash units only) - Sets delay between washes from 1 minute to 99 minutes
5. **Set Clock** - Day, hour and minutes
6. **AutoMode [M or A]** - Sets the C-6000 to Manual or Automatic modes. In Automatic mode, the C-6000 will start the Fan and Wash at the preset times that were set using the Set Wash Times option.

A = Automatic / M = Manual

Also allows individual days (Mon, Tues., etc.) to be set ON or OFF when Automatic mode is selected.

7. **Set Wash Times** - Sets Start Times for Automatic start of Fan and wash when C-6000 is set to Automatic mode.
8. **Wash Test** - Runs through a complete Wash Cycle with decreased times

Damper Closing Time = 10 sec.
Wash Times = 10 sec.
Water Heating Time = 10 sec.
Exits menu when finished.

9. **Number of Washes** - Preset at factory and protected with a password. Allows the number of washes to be changed from 1 to 5 (S1 to S5).

Spanish (Español) Instructions:

The C-6000 Command Center has the ability to display its commands and messages in either English or Spanish (Español).

Press the "ENGLISH / ESPAÑOL" [F3] button to toggle the language displayed from English to Spanish (Español) or from Spanish (Español) to English.

NOTE: All messages displayed by pressing the "MENU" [F4] button only appear in English. They will not appear in Spanish (Español).

Using the Menu:

To Enter the Menu, press the **MENU** button [F4].

To navigate the Menu:

- Press [F1] to go to the Next menu item
- Press [F2] to go to the Previous menu item

MODEL C-6000 SERIES COMMAND CENTER - INSTRUCTIONS

- Press [F5], the **EXIT** button to exit the Menu
 - Press [F6], the **ENTER** button to select a Menu item
- 1. Service**
 - Press [F6] [**ENTER**] to display Gaylord's web site address: gaylordusa.com
 - Press [F5] [**EXIT**] to return to the menu
 - 2. Detergent**
 - Press [F6] [**ENTER**] to display the Phone Number to order Detergent: 800-286-2010
 - Press [F5] [**EXIT**] to return to the menu
 - 3. Wash Length**
 - Press [F6] [**ENTER**] to display the Length of Wash #1
 - Press [F3] to Increase the Wash Time up to 9 Minutes (Maximum)
 - Press [F4] to Decrease the Wash Time down to 3 Minutes (Minimum)
 - Press [F1] to adjust the Length of Wash #2 (if applicable)
 - Press [F5] [**EXIT**] to return to the menu
 - Note: Press [F1] to advance through all washes (ex. "-S2" has 2 washes)
 - 4. Delay Time**
 - Press [F6] [**ENTER**] to display the Delay Time between washes (Not used if there is only one wash)
 - Press [F3] to Increase the Delay Time up to 99 Minutes (Maximum)
 - Press [F4] to Decrease the Delay Time down to 1 Minute (Minimum)
 - Press [F5] [**EXIT**] to return to the menu
 - 5. Set Clock**
 - Press [F6] [**ENTER**] to display the current Day of the Week (1=Sunday)
 - Press [F3] to change to the next Day of the Week (1=Sun, 2=Mon, 3=Tues, etc.), keep pressing [F3] to cycle around if necessary
 - Press [F1] to go to the current Hour
 - Press [F3] to increase the Hour, keep pressing [F3] to cycle around if necessary
 - Press [F1] to go to the current Minute
 - Press [F3] to increase the Minute, keep pressing [F3] to cycle around if necessary
 - Press [F5] [**EXIT**] to return to the menu
 - 6. AutoMode [A or M]**
 - Used to select [M]annual or [A]utomatic mode. If [A] is displayed, the C-6000 is set to operate in Automatic mode. If [M] is displayed, the C-6000 is set to operate in Manual mode.
 - Press [F6] [**ENTER**] to display the "Set Mode" screen
 - Press [F6] [**ENTER**] again to toggle between [M]annual or [A]utomatic mode
- Setting Which Days of the Week to Run:
- Press [F1] to select which days to run the C-6000 in Automatic mode
 - "Sun ON" or "Sun OFF" will display
 - Press [F3] to set a day to "ON". Set a day to "ON" in order for the C-6000 to run on that day
 - Press [F4] to set a day to "OFF". Set a day to "OFF" in order for the C-6000 NOT to run on that day
 - Press [F1] to cycle through each day of the week [Sun - Sat.]
 - Press [F5] [**EXIT**] to return to the menu
- 7. Set WashTimes**
 - Only used when C-6000 is set to Automatic mode
 - 8. Wash Test**
 - Press [F6] [**ENTER**] to display the Start time for the Fan on Sunday (**Sun. Fan**)
 - Press [F3] to increase the Hour
 - Press [F4] to increase the Minutes
 - Press [F1] to go to the Start time for the Wash on Sunday (**Sun.Wash**)
 - Set the time, using the same method described above
 - Press [F1] to cycle through for each day of the week, for the Start Times for the Fan and Wash
 - Press [F5] [**EXIT**] to return to the menu
 - 9. Number of Washes**
 - Pressing [F6] [**ENTER**] will prompt for a password. It is not necessary to change this value. It is preset at the Factory.
- TIME CLOCK OPERATION**

AutoMode is used to have C-6000 start the exhaust/supply fans automatically, once per day. The AutoMode also stops the fans and starts the wash cycle, once per day.

To use the AutoMode:

 - Set Wash Length(s) (Menu item #3)
Set length of each wash cycle, from 3 minutes to 9 minutes
 - Set Delay Time between washes, if control has more than one wash solenoid (Menu item #4)
Set amount of time to wait between washes, from 1 minute to 99 minutes
 - Set Clock (Menu item #5)
Please note that the clock is a 24-hour clock.
Example: 1:00 PM = 13:00
Set the current day of the week.
Example: 1 = Sun. 2 = Mon. 3 = Tues, etc.
 - Turn AutoMode ON (Menu item #6)
Pressing (F6) Enter will toggle between [A]utomatic and [M]annual modes
After it is set to [A]utomatic mode, set which days of the week the Exhaust/Supply Fan will run - setting a day to "ON" means the Exhaust/Supply Fan will start on that day, and the Wash will run.
Example:
Sun ON
Mon OFF
Tues ON
 - Set Wash Times, set start times for Fans & Wash (Menu item #7).
Set the time for the Fans to Start for each day of the week.
Example:
Sun. Fan 5:00
Mon.Fan 5:00
Set the time for the Wash to Start for each day of the week.
Example:
Sun.Wash 22:00
Mon.Wash 22:00

MODEL C-6000 SERIES MENU FUNCTIONS

MENU FUNCTION	DISPLAY READS
<p>1. Service - To obtain website address for a list of service agencies Press [F1] until "(1) Service" appears.</p>	(1) Service F1>Next F2>Prev (Toggles with) F5>Exit F6>Enter
Press [F6] [ENTER] to display Gaylord's web site address: gaylordusa.com	For Service: gaylordusa.com (Toggles with) F5>Exit
Press [F5] [EXIT] to return to the menu	
<p>2. Detergent - To obtain phone number of G-510 Press [F1] until "(2) Detergent" appears</p>	(2) Detergent F1>Next F2>Prev (Toggles with) F5>Exit F6>Enter
Press [F6] [ENTER] to display the Phone Number to order Detergent: 1-800-286-2010	For Detergent: 1-800-286-2010 (Toggles with) F5>Exit
Press [F5] [EXIT] to return to the menu	
<p>3. To Set Wash Length Press [F1] until "(3) Wash Length" appears</p>	(3) Wash Length F1>Next F2>Prev (Toggles with) F5>Exit F6>Enter
Press [F6] [ENTER] to display the Length of Wash #1	Wash1 Time: 3MIN (Range from 3 Min. to 9 Min.)
Press [F3] to Increase the Wash Time up to 9 Minutes (Maximum) or Press [F4] to Decrease the Wash Time down to 3 Minutes (Minimum)	F3>Up F4>Down (Toggles with) F1>Next F5>Exit * Pressing F1>Next goes to Next Wash #2, etc. if control is set up as a Sequential control
Press [F1] to adjust the Length of Wash #2 (if applicable)	
Press [F5] [EXIT] to return to the menu	
<p>4. To Set Delay Time Press [F1] until "(4) Delay Time" appears</p>	(4) Delay Time F1>Next F2>Prev (Toggles with) F5>Exit F6>Enter
Press [F6] [ENTER] to display the Delay Time between washes (Not used if there is only one wash)	Delay Time: 1Min (Range from 1 Min. to 99 Min.)
Press [F3] to Increase the Delay Time up to 99 Minutes (Maximum) or Press [F4] to Decrease the Delay Time down to 1 Minute (Minimum)	F3>Up F4>Down (Toggles with) F5>Exit
Press [F5] [EXIT] to return to the menu	
<p>5. To Set Clock Press [F1] until "(5)Set Clock" appears</p>	(5) Set Clock F1>Next F2>Prev (Toggles with) F5>Exit F6>Enter
Press [F6] [ENTER] to display the current Day of the Week (1=Sunday)	Day 6 1=Sunday F3>Up F5>Exit (Toggles with) F1>Next F2>Prev
Press [F3] to change to the next Day of the Week (1=Sun, 2=Mon, 3=Tues, etc.), keep pressing [F3] to cycle around if necessary	
Press [F1] to go to the current Hour	Hour: 7
Press [F3] to increase the Hour, keep pressing [F3] to cycle around if necessary	F3>Up F5>Exit (Toggles with) F1>Next F2>Prev
Press [F5] [EXIT] to return to the menu	

MODEL C-6000 SERIES MENU FUNCTIONS

MENU FUNCTION	DISPLAY READS
<p>6. AutoMode [A or M] - Used to select [M]anual or [A]utomatic mode. If [A] is displayed, the C-6000 is set to operate in Automatic mode. If [M] is displayed, the C-6000 is set to operate in Manual mode. Press [F1] until "(6) Auto Mode" appears</p>	(6) AutoMode [M] F1>Next F2>Prev (Toggles with) F5>Exit F6>Enter
Press [F6] [ENTER] to display the "Set Mode" screen	Set Mode [M] (Can be either "M" for Manual or "A" for Automatic)
Press [F6] [ENTER] again to toggle between [M]anual or [A]utomatic mode	F6>[A]uto/[M]an (Toggles with) F1>Next F5>Exit
Setting which day of the week to run	
Press [F1] to select which days to run the C-6000 in Automatic mode "Sun ON" or "Sun OFF" will display	
Press [F3] to set a day to "ON". Set a day to "ON" in order for the C-6000 to run on that day Press [F4] to set a day to "OFF". Set a day to "OFF" in order for the C-6000 NOT to run on that day	
Press [F1] to cycle through each day of the week [Sun – Sat.]	
Press [F5] [EXIT] to return to the menu	
<p>7. Set Wash Times - Used only when C-6000 is set to Automatic mode. Press [F1] until "(7) Set Wash Time" appears</p>	(7) SetWashTimes F1>Next F2>Prev (Toggles with) F5>Exit F6>Enter
Press [F6] [ENTER] to display the Start time for the Fan on Sunday (Sun. Fan)	Sun. Fan [14:24]
Press [F3] to increase the Hour Press [F4] to increase the Minutes	F3>Hour F4>Min. (Toggles with) F1>Next F5>Exit
Press [F1] to go to the Start time for the Wash on Sunday (Sun.Wash) Set the time, using the same method described above	Sun.Wash [14:24]
Press [F1] to cycle through for each day of the week, for the Start Times for the Fan and Wash	F3>Hour F4>Min. (Toggles with) F1>Next F5>Exit * Pressing F1>Next - goes to Next Start Fan time, etc
Press [F5] [EXIT] to return to the menu	
<p>8. Wash Test Press [F1] until "(8) Wash Test" appears</p>	(8) Wash Test F1>Next F2>Prev (Toggles with) F5>Exit F6>Enter
Press [F6] [ENTER] to run the C-6000 through a complete Wash cycle with decreased times	* Pressing F6>Enter - Starts the Wash Test
<p>9. Set Number of Washes Press [F1] until "(9) # of Washes" appears</p>	(9) # of Washes F1>Next F2>Prev (Toggles with) F5>Exit F6>Enter
Press [F5] [EXIT] to return to the menu	

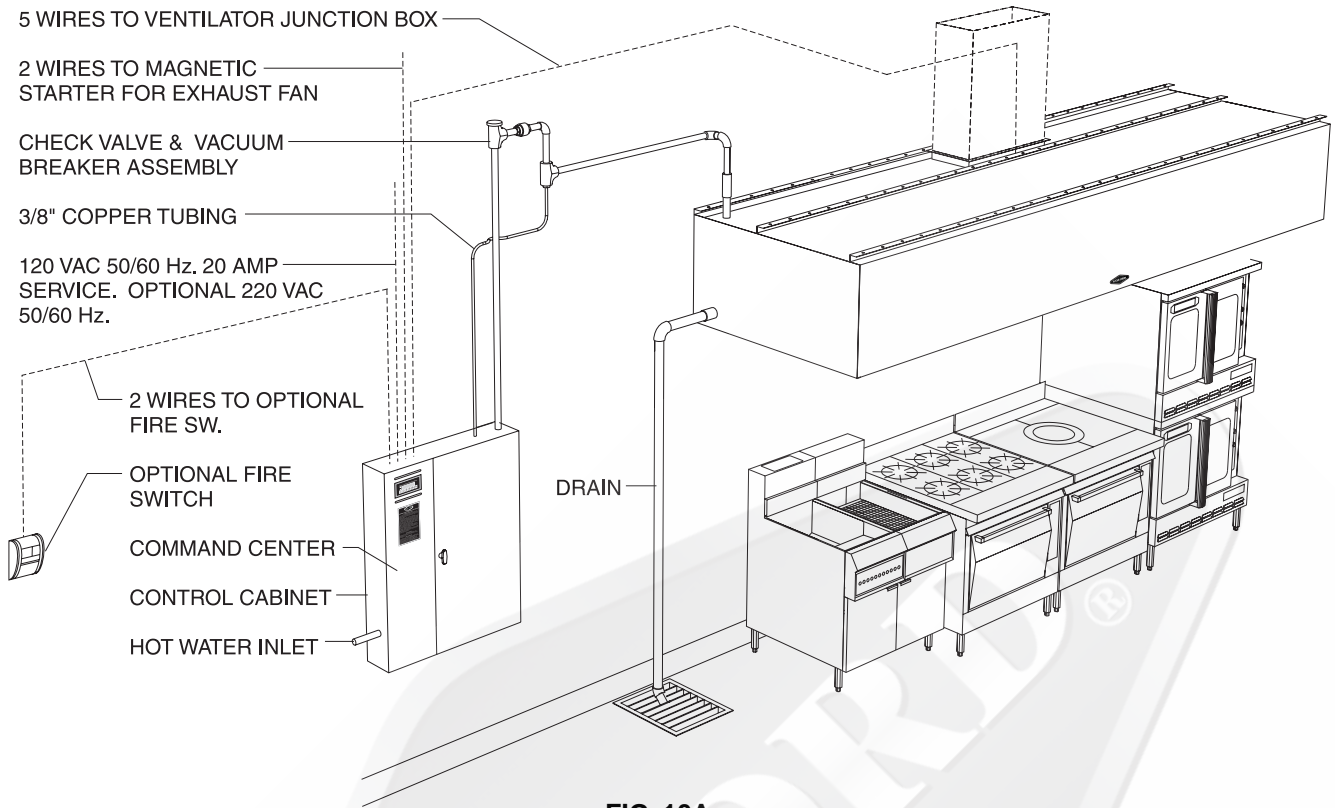

FIG. 10A
TYPICAL ARRANGEMENT WITH VACUUM BREAKER/CHECK VALVE FOR BACKFLOW PREVENTION

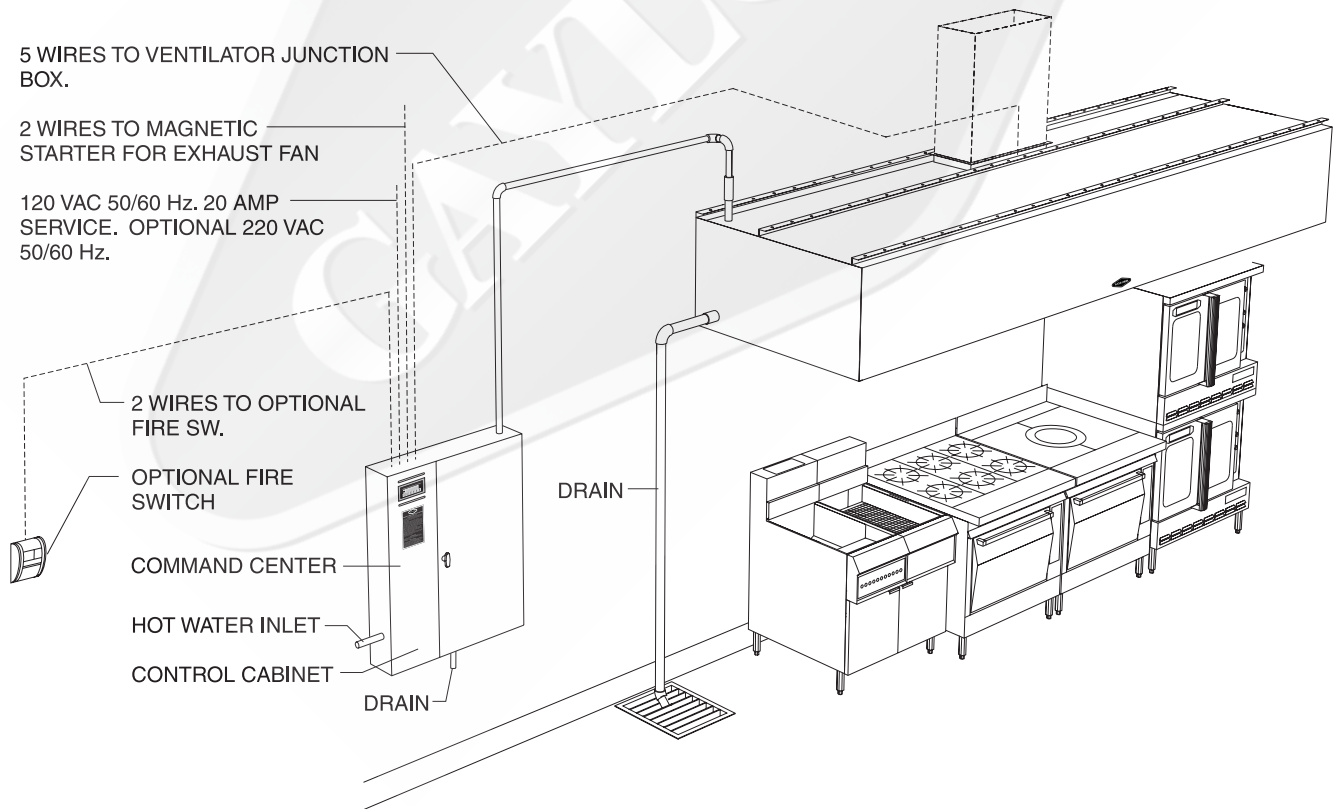

FIG. 10B
TYPICAL ARRANGEMENT WITH BUILT-IN "RP" DEVICE FOR BACKFLOW PREVENTION

Each Gaylord Ventilator is engineered to properly ventilate the specific cooking operation. The exhaust air volume is engineered as a specific volume per lineal ft. of ventilator and is determined by the type of cooking equipment being ventilated. The following Air Volume Chart lists the various volumes per lineal ft. designs.

AIR VOLUME CHART (Imperial)		
Model AB, BD, BDL Series	Desired CFM Per Lineal Foot	Static Pressure At Duct Collar
		150*
	250	1.33
	285	1.65
	300	1.70
	400	1.65
	405	1.70
	450	2.00
	470	2.15
	500	2.40
Model BDL-DS Series	Total Both Slots	
	400	1.65
	500	2.15

* With Custom Air Baffles

A ventilator may be designed to operate at two different air volumes. For example, half the ventilator may operate at 150 CFM/Lin. Ft. by utilizing "Custom Air" Baffles, and the other half at 250 CFM/Lin. Ft.

Refer to "Measuring Inlet Slot Velocity" on Page 21 for instructions on how to determine the designed Air Volume/Lin. Ft.

The total exhaust volume for each ventilator is stamped on the ventilator nameplate. (Refer to Figure 13 on Page 23.)

DUCT VELOCITY

Based between 1700 FPM - 1900 FPM

WATER TEMPERATURE REQUIREMENTS

140°F Min. - 180°F Max.

HOT WATER PRESSURE REQUIREMENTS

40 PSI Min. - 80 PSI Max.

HOT WATER CONSUMPTION

Single Wash - .60 GPM/Lineal Ft. @ 40 PSI Average
.90 GPM/Lineal Ft. @ 80 PSI Average

Dual Wash - 1.14 GPM/Lineal Ft. @ 40 PSI Average
1.67 GPM/Lineal Ft. @ 80 PSI Average

The length of the wash cycle may be set between 3 minutes and 9 minutes. The length of time is dependent upon the type of cooking equipment being used. Typical settings are 3 minutes for light-duty equipment, 5 minutes for medium-duty equipment, and 9 minutes for heavy-duty equipment. However, adequate cleaning is dependent upon water pressure, water temperature, daily grease accumulation, the length of the wash cycle, frequency of wash cycle and the type of detergent being used. It may be necessary to increase the wash time to achieve proper cleaning. Refer to page 15 for details on setting the wash time.

ELECTRICAL REQUIREMENTS

Standard voltage 120 volt, 50/60 Hz. Provide 24 hour, 20 amp service.

Optional voltage 220 volt, 50/60 Hz. 220 volt. All controls are marked with their operating voltage. See pages 42 through 49.

RP DEVICE

The reduced pressure principle device (RP) is required to prevent contaminated water from backflowing upstream to potable water. The unit provided in the Gaylord control cabinet is manufactured by Watts Regulator Co.

1. **Initial Start-up** - To avoid water hammer or shock damage perform the following initial start-up procedures:
 - A. Close the outlet hand valve.
 - B. Open the inlet hand valve slowly, fill the valve and bleed the air through test cock number 2, 3, and 4.
 - C. When the valve is filled, open the outlet hand valve slowly and fill the remaining supply system. The initial start-up procedure is now complete.

The reduced pressure principle device type backflow preventer (Refer to Figure 11A & 11B) consists of two primary chambers with spring loaded check valves and a secondary chamber with a spring loaded relief valve. This device prevents backflow by opening and closing the check valves if the pressure from the inlet side to the outlet side of the device varies.

1. **Intermittent Discharge** - Intermittent discharge of water through the relief valve is fairly common and usually occurs if there is inlet pressure fluctuations of more than 3 psi and when the solenoid valve closes after a wash cycle.
2. **Continuous Discharge** - If there is continuous discharge of water out the relief valve when the ventilator is not in a wash cycle, do the following:

- A. Leave the inlet hand valve open and close the outlet hand valve. If there is still continuous discharge it indicates that foreign material is preventing the first check valve from closing. If flushing will not clear the unit, remove and clean the first check valve.
- B. If there is continuous discharge of water out of the relief valve during a wash cycle, there is foreign material preventing complete closing of the relief valve. Flushing the relief valve may correct this condition.

Repeat procedure if necessary. If flushing does not stop discharge with flow through the device, remove and clean relief valve.

In no case should the relief valve outlet port be plugged, closed off or restricted.

This device should be inspected occasionally for continual discharge from the relief valve, which indicates a need for maintenance. It is recommended that the RP device be inspected and tested once a year.

NOTE: Some regulations require annual inspection and testing by a company certified to perform such duties.

See Instruction Manual IS-TK-DP, obtainable from your Watts installer or distributor. For the name of your nearest installer or distributor, call Watts Regulator at (978) 688-1811.



FIGURE 11A
REDUCED PRESSURE PRINCIPLE DEVICE
BACKFLOW PREVENTER

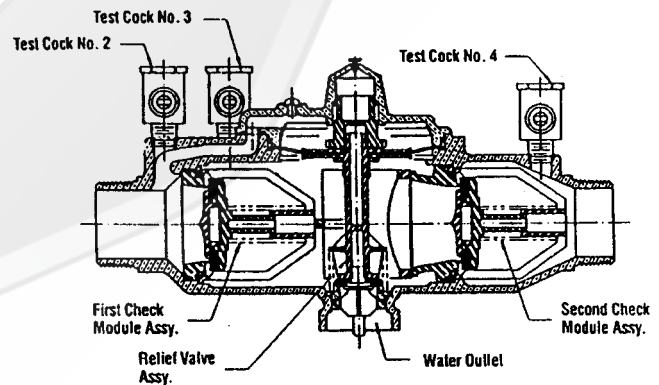

FIGURE 11B
REDUCED PRESSURE PRINCIPLE DEVICE
BACKFLOW PREVENTER

MEASURING INLET SLOT VELOCITY

Smoke capture and grease extraction efficiency are dependent upon the proper air velocity at the inlet slot of the ventilator.

The “Air Velocity Chart” below gives the optimum inlet slot velocity and the minimum and maximum allowed velocities. If the slot velocity is below or above the minimum or maximum, the exhaust fan must be adjusted accordingly.

NOTE: The height of the inlet slot can vary depending upon the design of the ventilator. It is, therefore, important to first measure the inlet slot and compare it to the chart below to determine the required average inlet slot velocity. The designed air volume per lineal foot is related to the velocity as shown on the chart below. The total air volume for the ventilator can be found on the ventilator nameplate. (Refer to Figure 13).

Air velocity readings less than what is specified on the “Air Velocity Chart” may allow smoke and grease to escape the confines of the ventilator and/or reduce grease extraction efficiency. This can result in grease deposits which lead to sanitation problems or fire hazards if left uncorrected. If the air velocity readings are higher than the maximum allowed, it will require more energy to operate the exhaust fan, excessive noise levels will result, and grease can be pulled through the extractor depositing in the duct and fan.

Higher or lower velocities than the allowed will normally put the entire heating and ventilating system out of balance.

AIR VELOCITY CHART

FOR ALL "CG3" SERIES EXCEPT "DS" SERIES								
Nominal Height of Inlet Slot	Without Custom Air Baffles				With Custom Air Baffles			
	Designed CFM per Lineal Ft.	Average Inlet Slot Velocity (FPM)			Designed CFM per Lineal Ft.	Average Inlet Slot Velocity (FPM)		
		Min.	Optimum	Max.		Min.	Optimum	Max.
3"	250	1300	1380	1450	150	760	800	880
	270	1360	1435	1500	160	790	830	870
	285	1425	1500	1575	170	810	855	900
	300	1465	1545	1625	180	845	880	935
4"	400	1690	1780	1870	250	1040	1095	1150

FOR "DS" SERIES VENTILATORS*						
Designed CFM Per Lineal Ft.			Required Average Inlet Slot Velocity (FPM)			
Total Both Slots	Front Slot	Rear Slot	Front Slot		Rear Slot	
			Min.	Optimum	Max.	Min.
300	150	150	760	800	880	595 625 655
400	250	150	1375	1450	1520	595 625 655

*The nominal height of the front inlet slot on “DS” series ventilators is always 3”.

MEASURING INLET SLOT VELOCITY

The standard instrument used for measuring the inlet velocities on a Gaylord Ventilator is a Pacer, Model DA40 or DA4000 Digital Anemometer. This instrument is the easiest, most accurate and the best suited for measuring ventilator inlet slot velocities. To take accurate air velocity readings, follow the instructions at right.

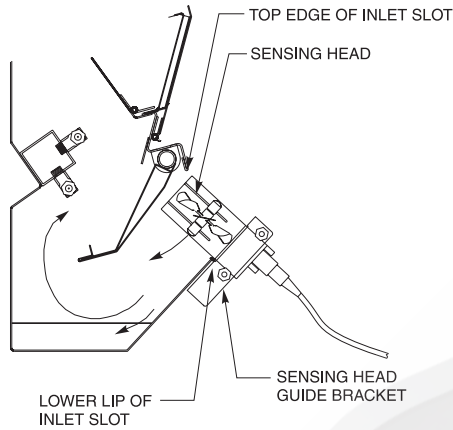

FIG. 12A

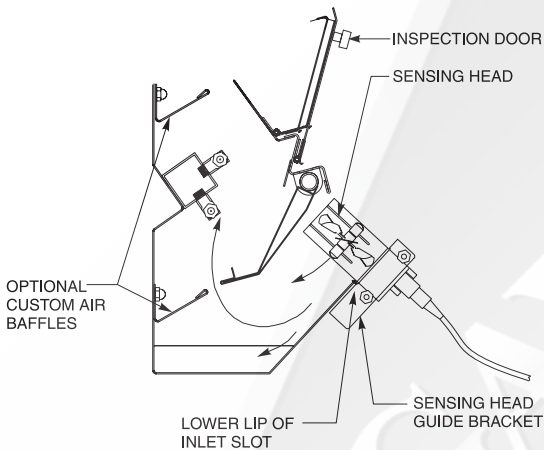

FIG. 12B

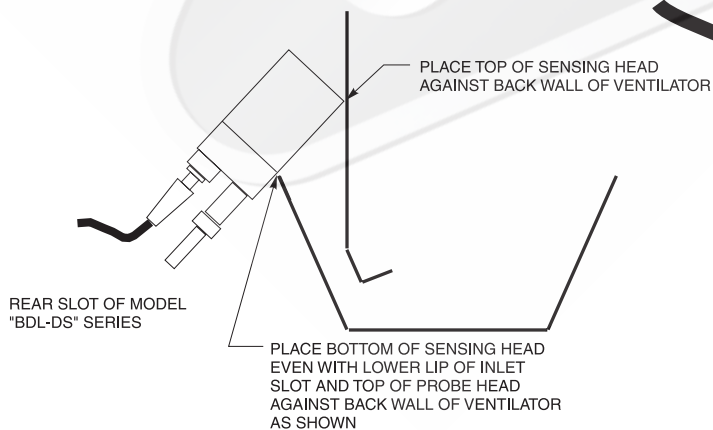

FIG. 12C

CROSS SECTION OF TYPICAL VENTILATOR INLET SLOTS

Instructions

1. It is first necessary to determine if the ventilator includes Custom Air baffles as shown in fig. 12B. If shop drawings are available, and if equipped, the custom baffles and their location will be noted on the front elevation. If not available, to determine if Custom Air baffles are provided, open the inspection door and look for the top custom air baffle, as shown in Fig. 12B.
2. If the ventilator includes Custom Air baffles, it will be necessary to take two sets of readings - one for the section of ventilator that includes Custom Air baffles and one where it does not.
3. Attached the sensing head guide bracket, Gaylord Part Number 18408, to the sensing head.
4. Attach the cable from the sensing head to the meter and the handle sections to the sensing head.
5. Place the sensing head guide bracket against the lower lip of the inlet slot as illustrated.
6. Using the 16 second averaging feature on the meter, slide the sensing head along the slot, back and forth, for a 3'-0" to 4'-0" distance, and record the velocity at the end of the 16 second mark. Continue this process for the full length of the ventilator.

Important Note: If the ventilator includes custom air baffles as illustrated in Fig. 12B, always take separate readings on the section of the ventilator that includes custom air from the section that does not have the baffles. Non custom air and custom air readings must be recorded separately. Do not average them together.

Important Note: On the rear slot of a Model BDL-DS Series, do not use the guide bracket. Refer to Figure 12C.



7. Record the velocity (fpm) on the start up inspection report form. A sample report form, which can be photocopied, is provided on page 52.

8. The designed, or optimum velocity, is noted on the shop drawings and the Air Velocity Chart on page 21. Two velocities will be noted if the ventilator includes custom air baffles.

9. Compare the recorded air velocity to the designed air velocity shown on the shop drawings or the Air Velocity Chart on page 21. The recorded velocity may be slightly lower or higher providing that it is within the minimum and maximum range as shown on the Air Velocity Chart .

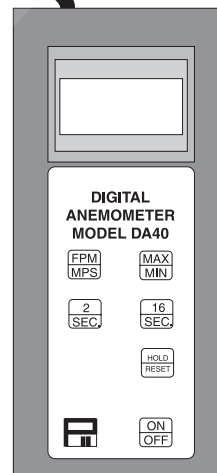
If the air velocity is outside the minimum/maximum range, the performance of the ventilator will be affected and therefore the exhaust fan **must** be adjusted.



<div style="text-align: center;">  <p>GAYLORD</p> </div> <div style="text-align: center;">  <p>UL LISTED 370Y</p> </div> <p style="text-align: center;">EXHAUST HOOD WITH EXHAUST DAMPER</p> <p>THIS EXHAUST HOOD IS ALSO LISTED AS AN EXHAUST HOOD WITHOUT EXHAUST DAMPER WHEN EQUIPPED WITH FIRE DAMPER LOCKOUT PART NUMBER FDL.</p> <p>FOR USE ONLY WITH GAYLORD INDUSTRIES LISTED SUB-ASSEMBLY CONTROL CABINET MODEL NUMBER GPC-5000-99 OR GPC-6000 SERIES</p> <p>THIS EXHAUST HOOD HAS BEEN TESTED TO STANDARD UL 710 "EXHAUST HOODS FOR COMMERCIAL COOKING EQUIPMENT"</p> <p>THIS EXHAUST HOOD IS LISTED UNDER UL FILE NUMBER MH11403</p> <p>THIS EXHAUST HOOD MEETS ALL REQUIREMENTS OF THE LATEST EDITION OF NFPA-96 AND THE IMC (INTERNATIONAL MECHANICAL CODE)</p> <p style="text-align: center;">PATENT PENDING</p>	<div style="text-align: center;"> <p>ENGINEERING DATA</p> </div> <table style="width: 100%; border-collapse: collapse;"> <tr> <td style="width: 60%;">1. MINIMUM TOTAL EXHAUST VOLUME FOR THIS HOOD SECTION</td> <td style="width: 10%; border: 1px solid black; height: 20px;"></td> <td style="width: 30%; text-align: right;">C.F.M.</td> <td rowspan="2" style="width: 10%; vertical-align: middle;"> TOTAL EXHAUST CFM HERE TOTAL SUPPLY CFM HERE </td> </tr> <tr> <td>2. MAXIMUM TOTAL SUPPLY VOLUME FOR THIS HOOD SECTION</td> <td style="border: 1px solid black; height: 20px;"></td> <td style="text-align: right;">C.F.M.</td> </tr> <tr> <td>3. EXHAUST STATIC PRESSURE AT DUCT COLLAR</td> <td style="border: 1px solid black; height: 20px;"></td> <td style="text-align: right;">W.G.</td> <td></td> </tr> <tr> <td>4. SUPPLY STATIC PRESSURE AT DUCT COLLAR</td> <td style="border: 1px solid black; height: 20px;"></td> <td style="text-align: right;">W.G.</td> <td></td> </tr> </table> <p>5. THIS HOOD SECTION SUITABLE FOR APPLIANCES WITH MAXIMUM COOKING SURFACE TEMPERATURE OF:</p> <table style="width: 100%; border-collapse: collapse;"> <tr> <td style="width: 15%; border: 1px solid black; height: 20px;"></td> <td style="width: 5%; text-align: center;">°F</td> <td style="width: 10%;">FOR</td> <td style="width: 15%; border: 1px solid black; height: 20px;"></td> <td style="width: 55%;">LINEAL FT. OF HOOD</td> </tr> <tr> <td style="border: 1px solid black; height: 20px;"></td> <td style="text-align: center;">°F</td> <td>FOR</td> <td style="border: 1px solid black; height: 20px;"></td> <td>LINEAL FT. OF HOOD</td> </tr> </table> <p>6. REFER TO GAYLORD VENTILATOR TECHNICAL MANUAL FOR INLET SLOT VELOCITY REQUIREMENTS AND METHOD OF CHECKING VELOCITY</p> <p>7. ELECTRICAL RATING OF LIGHT FIXTURES: 120 VOLT, 60HZ. OR 220 VOLT, 50HZ. OVERALL RATING - 12 AMPS OR LESS</p> <p>8. VENTILATOR ELECTRICAL CONTROL CIRCUIT MUST BE FUSED SEPARATELY</p> <p>9. IF HOOD IS EQUIPPED WITH INTEGRAL MAKE-UP AIR WITH FUSE LINK OPERATED FIRE DAMPER USE ONLY 165° F, RATED 30 LBS. MIN. UL LISTED FUSIBLE LINKS FOR REPLACEMENT</p> <p>10. DUCTWORK AND EXHAUST FAN</p> <p style="margin-left: 20px;">A. STATIC PRESSURE OF DUCT SYSTEM MUST BE ADDED TO VENTILATOR STATIC FOR TOTAL SYSTEM STATIC</p> <p style="margin-left: 20px;">B. ALL DUCTWORK MUST BE WELDED LIQUID TIGHT</p> <p><input type="checkbox"/> SUPPLIED WITH FACTORY INSTALLED UL LISTED GRINNELL CORP. EA-1, 1/4" ORIFICE, 65 DEGREE DEFLECTOR SPRINKLER(S) FOR THE PROTECTION OF UNLIMITED LENGTH OF GREASE DUCT HAVING A MAXIMUM DUCT PERIMETER OF 50 INCHES PER SPRINKLER. CONNECT TO NFPA 13 SPRINKLER SYSTEM WATER SUPPLY ONLY.</p> <p>SERIAL NO: </p> <p>MODEL NO: </p>	1. MINIMUM TOTAL EXHAUST VOLUME FOR THIS HOOD SECTION		C.F.M.	TOTAL EXHAUST CFM HERE TOTAL SUPPLY CFM HERE	2. MAXIMUM TOTAL SUPPLY VOLUME FOR THIS HOOD SECTION		C.F.M.	3. EXHAUST STATIC PRESSURE AT DUCT COLLAR		W.G.		4. SUPPLY STATIC PRESSURE AT DUCT COLLAR		W.G.			°F	FOR		LINEAL FT. OF HOOD		°F	FOR		LINEAL FT. OF HOOD
1. MINIMUM TOTAL EXHAUST VOLUME FOR THIS HOOD SECTION		C.F.M.	TOTAL EXHAUST CFM HERE TOTAL SUPPLY CFM HERE																							
2. MAXIMUM TOTAL SUPPLY VOLUME FOR THIS HOOD SECTION		C.F.M.																								
3. EXHAUST STATIC PRESSURE AT DUCT COLLAR		W.G.																								
4. SUPPLY STATIC PRESSURE AT DUCT COLLAR		W.G.																								
	°F	FOR		LINEAL FT. OF HOOD																						
	°F	FOR		LINEAL FT. OF HOOD																						
<p style="text-align: center;">WORLD HEADQUARTERS</p> <p style="text-align: center;">GAYLORD INDUSTRIES, INC.</p> <p style="text-align: center;">10900 S.W. AVERY STREET TUALATIN, OR 97062-8549 USA</p> <p style="text-align: center;">PHONE: 1-503-691-2010 FAX: 1-503-692-6048 EMAIL: info@gaylordusa.com</p> <p style="font-size: small;">UL-CG31001</p>	<div style="text-align: center;"> <p>HOOD MOUNTING REQUIREMENTS</p> </div> <table style="width: 100%; border-collapse: collapse;"> <tr> <td style="width: 70%;">MINIMUM DISTANCE FROM COOKING SURFACE TO FRONT LOWER EDGE OF HOOD</td> <td style="width: 30%; border: 1px solid black; height: 20px;"></td> </tr> <tr> <td>MAXIMUM DISTANCE FROM COOKING SURFACE TO FRONT LOWER EDGE OF HOOD</td> <td style="border: 1px solid black; height: 20px;"></td> </tr> <tr> <td>MINIMUM OVERHANG FROM FRONT OF HOOD CAVITY TO FRONT OF COOKING SURFACE</td> <td style="border: 1px solid black; height: 20px;"></td> </tr> <tr> <td>MAXIMUM SETBACK FROM FRONT OF HOOD CAVITY TO FRONT OF COOKING SURFACE</td> <td style="border: 1px solid black; height: 20px;"></td> </tr> <tr> <td>MINIMUM OVERHANG FROM SIDE OF HOOD TO EDGE OF COOKING SURFACE</td> <td style="border: 1px solid black; height: 20px;"></td> </tr> </table>	MINIMUM DISTANCE FROM COOKING SURFACE TO FRONT LOWER EDGE OF HOOD		MAXIMUM DISTANCE FROM COOKING SURFACE TO FRONT LOWER EDGE OF HOOD		MINIMUM OVERHANG FROM FRONT OF HOOD CAVITY TO FRONT OF COOKING SURFACE		MAXIMUM SETBACK FROM FRONT OF HOOD CAVITY TO FRONT OF COOKING SURFACE		MINIMUM OVERHANG FROM SIDE OF HOOD TO EDGE OF COOKING SURFACE																
MINIMUM DISTANCE FROM COOKING SURFACE TO FRONT LOWER EDGE OF HOOD																										
MAXIMUM DISTANCE FROM COOKING SURFACE TO FRONT LOWER EDGE OF HOOD																										
MINIMUM OVERHANG FROM FRONT OF HOOD CAVITY TO FRONT OF COOKING SURFACE																										
MAXIMUM SETBACK FROM FRONT OF HOOD CAVITY TO FRONT OF COOKING SURFACE																										
MINIMUM OVERHANG FROM SIDE OF HOOD TO EDGE OF COOKING SURFACE																										

**FIG. 13
VENTILATOR NAME PLATE**

OPTIONAL CONTINUOUS COLD WATER MIST

GENERAL

Continuous cold water mist is an option on all "CG3" Series ventilators and is typically used on ventilators that cover solid fuel burning appliances such as mesquite broilers.

Continuous cold water mist ventilators incorporate a water manifold with spray nozzles, located at the lower edge of the air inlet slot. (Refer to Figure 14) When the exhaust fan is started, the solenoid valve in the cold water loop in the Gaylord control cabinet opens (refer to illustration on Page 36), turning on the mist nozzles which remain on as long as the exhaust fan is on. The nozzles produce a very fine mist and are located so that the entire air stream passes through the mist. The purpose of the mist is to knock down any hot embers, produced by the solid fuel, that may be drawn up into the ventilator and to cool down the exhaust air.

ENGINEERING

1. **Pipe Size** - 1/2" cold water supply required to the control cabinet.
2. **Water Pressure** - 40 psi flow pressure. The control cabinet is equipped with an adjustable pressure regulator.
3. **Water Consumption** - .66 gph/lineal ft. of ventilator.

MAINTENANCE

Every six months check the following:

1. **Water Pressure** - Turn on the exhaust fan, opening the control cabinet door and check the water pressure gauge in the cold water loop. Water flow pressure should be at 40 psi. If it is not, adjust the pressure regulator until 40 psi is achieved.
2. **Mist Nozzles** - Turn on the exhaust fan, look into the air inlet slot and check each mist nozzle for proper spray. Remove and clean the nozzle if necessary.

TROUBLE-SHOOTING

1. If the mist nozzles do not come on when the fan is started, check the following:
 - A. Open the electrical compartment of the control cabinet and check to ensure that the cold water mist override switch is in the "On" position.
 - B. Check the cold water mist hand valve in the control cabinet to ensure that it is in the "Open" position.
 - C. Check the cold water mist solenoid coil for voltage. Also check the coil for continuity.
 - D. Foreign material in the cold water supply line may have clogged the solenoid valve and prevented its opening. If this is the case, a slight tap on the solenoid valve housing should release the valve.
2. If water mist is spraying out of the air inlet slot, check the following:
 - A. With the cold water mist on, open the control cabinet and check the pressure gauge to ensure that the flow pressure is not above 40 psi. Adjust the pressure reducing valve if necessary.
 - B. With the cold water mist on, check the mist nozzles for even spray. Foreign particles in the nozzle could cause an erratic mist causing it to come out the air inlet slot.

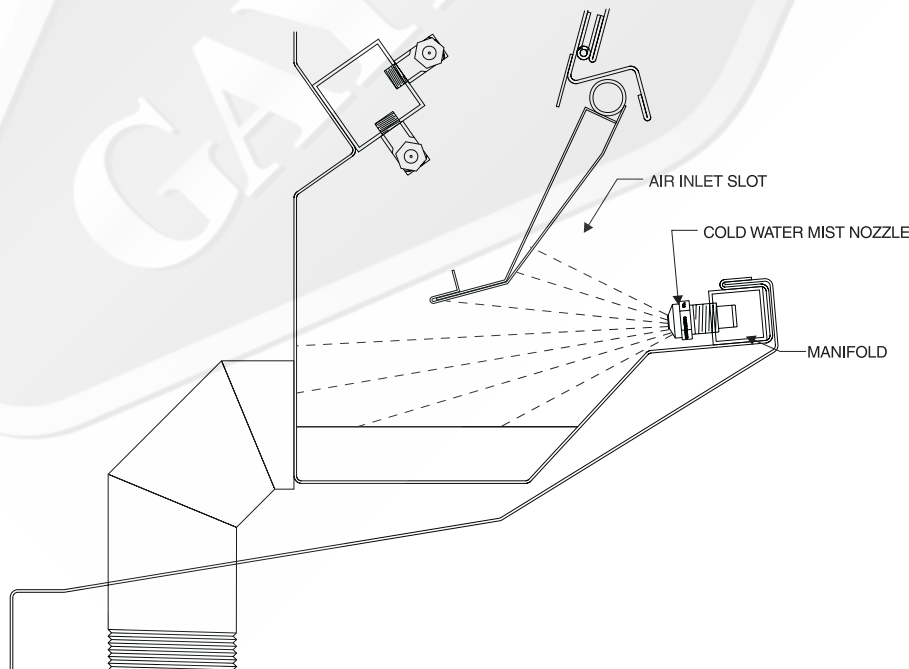
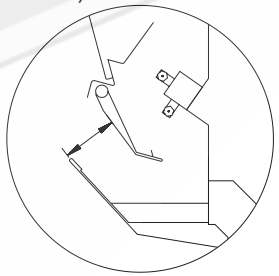

FIG. 14
CONTINUOUS COLD WATER MIST

C-6000 MODEL IDENTIFICATION

C-6000 VERSION	OUTPUT MODULE MODEL #	DESCRIPTION
6000-10	ICGL01-100	<p>This control will drive up to <u>10</u> damper motors (10 sections of ventilator with electric damper motors). It requires a 100VA Transformer with a reset button.</p> <p>Bottom Terminal = #19 Number of Fuses on Circuit Board = 4 # Damper Positioners = 1</p> <p>This module <u>does not</u> have GXT, CM, or #20 terminals on terminal strip <i>TB1</i>. It does have a GND (ground) terminal. It has 4 terminals on the <i>TB2</i> terminal strip on the lower portion of the board for the Damper Positioner.</p> <p>It is necessary to add a Relay and a terminal GXT for GX2 ventilators with Electric Dampers and normally closed thermostats, if required.</p> <p>It is necessary to add a terminal CM for Cold Water Mist if required, it would be tied into #8.</p>
6000-10-A	ICGL01-101	<p>This control will drive up to <u>10</u> damper motors (10 sections of ventilator with electric damper motors). It requires a 100VA Transformer with a reset button.</p> <p>Bottom Terminal = GXT Number of Fuses on Circuit Board = 4 # Damper Positioners = 1</p> <p>GXT, CM, and #20 terminals were added to and GND was removed from the <i>TB1</i> terminal strip. Relay #8 was added to accommodate GX2 (normally closed) thermostats.</p> <p>It has 6 terminals on the <i>TB2</i> terminal strip on the lower portion of the board. Terminals #5 and #6 were added to the <i>TB2</i> terminal strip to accommodate a 2nd Damper Positioner and the Fire Test Switch.</p> <p>** A Jumper is required from #6 from the <i>TB2</i> terminal strip to #3 on the <i>TB1</i> terminal strip.</p>
6000-10-B	ICGL02-102	<p>This control will drive up to <u>10</u> damper motors (10 sections of ventilator with electric damper motors). It requires a 100VA Transformer (Square D).</p> <p>Bottom Terminal = GXT Number of Fuses on Circuit Board = 6 # Damper Positioners = 0</p> <p>Jumpers J1 and J2 were added to this board.</p> <p>Fuses F5 and F6 were added to the circuit board.</p> <p>Terminal #20 was removed from this board on the <i>TB1</i> terminal strip. The terminals on <i>TB2</i> were re-labeled as H1, H2, X1, X2, TS1, and TS2.</p> <p>This control does NOT require a Damper Positioner.</p>
6000-20-B	ICGL02-102	<p>This control will drive up to <u>14</u> damper motors (14 sections of ventilator with electric damper motors). It requires a 250VA Transformer (Square D).</p> <p>Bottom Terminal = GXT Number of Fuses on Circuit Board = 6 # Damper Positioners = 0</p> <p>Jumpers J1 and J2 were added to this board.</p> <p>Fuses F5 and F6 were added to the circuit board.</p> <p>Terminal #20 was removed from this board on the <i>TB1</i> terminal strip. The terminals on <i>TB2</i> were re-labeled as H1, H2, X1, X2, TS1, and TS2.</p> <p>This control does NOT require a Damper Positioner.</p>

TROUBLE-SHOOTING

SYMPTOM	POSSIBLE PROBLEM	CORRECTIVE ACTION
SMOKE LOSS		
<p>1. Smoke Loss- Ventilator is not exhausting properly.</p>	<p>A. Low air velocity- Average air velocity through the air entry slot should be in accordance with the Air Velocity Chart on page 21. For proper method of measuring the air velocity, refer to page 22. If the velocity is low check the following.</p> <p>B. The Gaylord Ventilator must have its own exhaust system and no other exhaust, such as dishwasher hoods, should be tied into it.</p> <p>C. Improperly placed make-up air diffusers.</p> <p>D. Inadequate make-up air.</p> <p>E. Exhaust fan discharge.</p> <p>F. Damper not open to correct operating position. (N/A on CG3-FDD, CG3-FDT, and CG3-ND)</p> 	<ol style="list-style-type: none"> 1. Broken or slipping belt on the exhaust fan. 2. Proper rotation of the exhaust fan wheel. 3. Proper size of exhaust fan (fan must deliver nameplate rating). 4. Ductwork inspection panel left open. 5. Damper not open or in proper position. <ol style="list-style-type: none"> 1. Inspect duct system and verify that there are no other non ventilator systems tied in. If so they must be removed. <ol style="list-style-type: none"> 1. Make-up air directed at the ventilator will likely create cross drafts disrupting the air flow into the ventilator. Adjust the louvers to direct the make-up air away from the ventilator. 2. Make-up air should be delivered through registers at ceiling height, and distributed throughout the kitchen area. 3. Make-up air registers located near the ventilator, the louvers should be adjusted to direct the air away from the ventilator. Directing or forcing make-up air at the ventilator typically creates cross drafts resulting in smoke loss. <ol style="list-style-type: none"> 1. Make-up air must be supplied for replacement of air exhausted through all kitchen exhaust systems. 2. A general "rule of thumb" is that 75% to 80% of the replacement air should be fresh, conditioned, (heated or cooled) air brought into the kitchen area, with the remaining 20% to 25% allowed to flow into the kitchen from adjacent areas. <p style="padding-left: 20px;">There should be no screen over the discharge. If one is found, it should be removed.</p> <ol style="list-style-type: none"> 1. one is found, it should be removed. <p style="padding-left: 20px;">The direction of discharge should not be into the prevailing winds nor downward onto the roof. A vertical discharge is highly recommended.</p> <p style="padding-left: 20px;">Set the Damper Positioner(s) to 50 for Normal operation.</p> <ol style="list-style-type: none"> 1. operation. <p style="padding-left: 20px;">Measure the damper opening while in the operating position.</p> <p style="padding-left: 20px;">3" Throat - Set to 2 15/16"</p> <p style="padding-left: 20px;">4" Throat - Set to 3 3/4"</p> <p style="padding-left: 20px;">The damper Positioner should be set to 50, but if desired opening does not occur, decrease the Damper Positioner setting to increase the opening.</p>
GREASE EXTRACTION		
<p>1. Poor Grease Extraction.</p>	<p>A. The Gaylord "CG3" Series Ventilator extracts up to 95% of the grease, dust and lint particles from the airstream passing through it, when operated and maintained in accordance with design specifications. If it appears that the ventilator is not extracting properly, typically the exhaust volume is low.</p>	<ol style="list-style-type: none"> 1. Check the inlet slot velocity as described on pages 21 through 23. If the velocity is not within the required range, increase or reduce the fan speed as required.

TROUBLE-SHOOTING

SYMPTOM	POSSIBLE PROBLEM	CORRECTIVE ACTION
EXHAUST FAN		
<p>1. When the "Start Fan" button is pushed, the green light does not come on, and the damper does not move to the exhaust position.</p> <p>2. If when the "Start Fan" button is pushed, the green light comes on and the damper moves to the exhaust position but the exhaust fan does not come on.</p> <p>3. When the "Start Fan" button is pushed and after the 45 second delay, the exhaust fan comes on but the damper does not open.</p>	<p>A. No power in the control cabinet.</p> <p>B. The control is in an Internal Fire Mode.</p>	<p>1. Check the circuit breaker serving the control cabinet. The "Run" light on the "PLC" should be on at all times. If it is not on it indicates no power is getting to the control. Check all the fuses inside the control cabinet on output module, terminal blocks, and transformer.</p> <p>1. Check for continuity between #15 and GXT. If there is no continuity between #15 and GXT, refer to FIRE CYCLE in the TROUBLE -SHOOTING section.</p>
	<p>A. Overload protector on magnetic starter tripped.</p> <p>B. If an HOA (Hands On/Automatic) type magnetic starter switch is used, the selector switch may have been moved from the automatic position</p> <p>C. Exhaust fan circuit breaker tripped.</p> <p>D. If the system is equipped with a disconnect switch for the exhaust fan, a fuse or fuses may have blown out.</p>	<p>1. Push the "Reset" button on the magnetic starter and the push the "Start Fan" button on the command center.</p> <p>1. Check switch and turn selector to the automatic position.</p> <p>1. Reset circuit breaker</p> <p>1. Check continuity of fuses and replace if necessary.</p>
	<p>A. There may be an incomplete circuit between the damper motor and the C-6000 control. (N/A on CG3-FDD, CG3-FDT, and CG3-ND)</p> <p>B. There may be a problem with the PLC (Programmable Logic Controller) in the command center.</p> <p>If the PLC status lights check out, there may be a problem with the damper motor or the wiring going to the damper motor.</p> <p>C.</p> <p>D. The Damper Positioner(s) may be set incorrectly on C-6000 or C-6000-A.(N/A on CG3-FDD, CG3-FDT, and CG3-ND</p>	<p>1. Check outputs #17 & 19, on C-6000 for voltage (24 VAC).</p> <p>2. Check outputs #17 & 18, on C-6000, for voltage. C-6000 or C-6000-A Fan On = approx.6 VDC Fan Off = approx. 14 VDC C-6000-B Fan On = approx. 0 VAC Fan Off = approx. 24 VAC</p> <p>3. Check wiring connections at the ventilator J-boxes following wire numbers as described in A/1. & A/2 above.</p> <p>1. Check the appropriate status light on the PLC (Refer to the PLC status light chart on Page 31.)</p> <p>1. If there is more than one ventilator on the system visually check each damper. If only one out of two or more dampers is closed, check the control for mechanical failure. If mechanical components are ok, remove inspection panel and check lines 17 & 19</p> <p>1. Set the Damper Positioner(s) to 50 for Normal Operation.</p>
WASH SYSTEM		
<p>1. When the "Start Wash" button is pushed, the green light does not come on, and the damper does not move to the wash position.</p> <p>2. The ventilator is not washing properly.</p>	<p>A. The control is in an Internal Fire Mode.</p> <p>A. Water supply turned off or partially on.</p> <p>B. Low water pressure.</p> <p>C. Low water temperature</p>	<p>1. Check for continuity between #15 and GXT. If there is no continuity between #15 and GXT, refer to FIRE CYCLE in the TROUBLE -SHOOTING section.</p> <p>1. Check the hand valve inside the control cabinet.</p> <p>2. Check any valves upstream of the control cabinet.</p> <p>1. Check the water pressure gauge inside the control cabinet. Pressure should be 40 PSI min. while the ventilators are washing.</p> <p>1. Check the temperature gauge inside the control cabinet. The temperature should be between 140°F-180°F. If below temperature it must be increased.</p>

TROUBLE-SHOOTING

SYMPTOM	POSSIBLE PROBLEM	CORRECTIVE ACTION
WASH SYSTEM CONT.		
2. The ventilator is not washing properly.	D. Inadequate wash time	1. Increase length of wash time. The length of the wash cycle may be set between 3 and 9 minutes. Recommended times are: 3 minutes for light-duty equipment, 5 minutes for medium duty and 9 minutes for heavy-duty equipment. (Refer to wash timing instructions on Page 15 to adjust the length of wash cycle.)
	E. Clogged spray nozzles.	1. While the wash cycle is on, open the inspection door slightly and visually check spray of nozzles. If a nozzle is clogged, remove, and clean by running a small wire through it.
	F. Detergent pump lost its prime or not pumping properly.	1. Refer to Page 12 for trouble shooting detergent pump.
	G. Detergent tank empty.	1. Check and fill detergent weekly.
	H. Improper detergent.	1. Refer to Page 13 for recommended detergent.
	I. Inadequate wash frequency.	1. Normally only one wash is required in a cooking day. However, if the cooking operation is extremely heavy, such as char broiler and wok cooking it may be necessary to wash twice in a cooking day.
3. Water does not come on when "Start Wash" is pushed, but exhaust fan turns off and damper closes, to the wash position	A. Water supply turned off	1. Check hand valve inside control cabinet. 2. Check any hand valve upstream of control cabinet.
	B. Malfunctioning solenoid valve. If the pump is operating there is a problem with the valve or valve wiring.	1. Coil may be burned out. Check continuity. 2. Foreign material in the hot water supply line may have clogged the solenoid valve and prevented its opening. If this is the case, a light tap on the solenoid valve housing will release the valve.
	C. Malfunctioning PLC.	3. Check wiring diagram for proper wire # 9-13 and check for 120 volts during wash. 1. Check the appropriate status light on the PLC (Refer to PLC status light chart on Page 31). If the appropriate status light is not on, the PLC needs to be reprogrammed or possibly replaced.
	D. Loose connection to solenoid valve.	1. Tighten connection.
4. Water sprays on when the ventilator is not in a wash cycle ("Wash On" not displayed on command center).	A. If "Fire in Hood" is displayed on the C-6000 command center and the red light is on continuous. (N/A on CG3-FDD and CG3-ND)	1. The internal fire mode has been activated via thermostats. Refer to "Fire Cycle" in this trouble-shooting section.
	B. If "Ext. Fire Active" is displayed on the C-6000 command center and the red light is flashing.	1. The remote fire switch has been pulled. Refer to "Fire Cycle" in this trouble-shooting section.
	C. Debris stuck in solenoid valve.	1. Turn off the water and disassemble solenoid valve. Remove debris and reassemble.

TROUBLE-SHOOTING

SYMPTOM	POSSIBLE PROBLEM	CORRECTIVE ACTION
FIRE CYCLE		
<p>1. If the ventilator is in an internal fire cycle, "Fire in Hood" is displayed and the red light is on continuous, water sprays on and the damper closes to the fire position, but there is not a fire. (N/A on CG3-FDD and CG3-ND)</p> <p>2. If the ventilator is in an external fire mode "Ext. Fire Active" displayed and the red light flashes, water sprays on and exhaust fan on but there is no fire.</p> <p>3. If the damper is in the fire position but the unit is not in an internal fire mode ("Fire in Hood" displayed, water sprays on.) (N/A on CG3-FDD and CG3-ND)</p>	<p>A. Faulty thermostat, or break in thermostat circuit.</p> <p>A. The remote Fire Switch (If provided) has been pulled.</p> <p>B. The external fire mode may have been initiated from another source, such as a building alarm system, DDC system, pre-engineered fire system etc.</p> <p>A. There may be a problem with the PLC (Programmable Logic Controller) in the command center.</p> <p>B. If the PLC output lights check out, there may be a problem with the damper motor or the wiring going to the damper motor.</p> <p>C. The Damper Positioner on a C-6000 or C-6000-A may be set incorrectly.</p>	<p>1. Check continuity of thermostats and circuit. Refer to wiring diagram on Pages 42-49. Note: Thermostats are wired in parallel. Replace thermostat(s) if required. Check for jumper between GXT and 15. If GX2 hoods are connected, check for continuity between GXT and 15. If not, trace out circuit and find break.</p> <p>1. Open the Fire Switch and flip the toggle switch to the "Normal position". (Refer to Page 9 for illustration)</p> <p>1. Disconnect wires from terminals 4 and FS to isolate external sources. If external fire mode stops investigate external sources and remove cause.</p> <p>1. Check the appropriate status light on the PLC (Refer to the PLC status light chart on Page 31). If the output light is not on, the PLC needs to be reprogrammed or possibly replaced.</p> <p>1. If there is more than one ventilator on the system visually check each damper. If only one out of two or more dampers is closed, check the control for mechanical failure, etc. If mechanical components are ok, remove damper actuator access panel and check lines 17 and 19 for power. If there is power, then the damper motor must be replaced.</p> <p>1. Set the Damper Positioner on a C-6000 or C-6000-A to 50 for Normal operation.</p>
BACK FLOW PREVENTERS		
<p>Model GPC-6000-VB Series control cabinets use a vacuum breaker/check valve assembly for backflow prevention. Model GPC-6000 Series control cabinets use a reduced pressure principle device (RP) for backflow prevention. Refer to Pages 33 through 35 for illustrations of each. The type of backflow preventer used is dictated by state, county or city code.</p> <p>1. VACUUM BREAKERS Vacuum breaker leaks or spits either at the beginning or end of the wash cycle.</p>	<p>A. Improper Installation.</p> <p>B. Sticking check valve.</p> <p>C. Deteriorated check valve washers.</p>	<p>1. Vacuum breaker must be mounted 6" higher than line going to the ventilator. (See illustration on Page 18).</p> <p>1. Remove the top cap of the vacuum breaker and check to make sure the nylon check valve slides up and down on the guide stem properly, and that the stem is straight. Clean stem or straighten as necessary.</p> <p>1. Check to make sure that the rubber washer on top of the nylon check seats properly against the machined surface, and that the surfaces of both the rubber washer and the machined surface are smooth. Replace check if necessary.</p>

TROUBLE-SHOOTING

SYMPTOM	POSSIBLE PROBLEM	CORRECTIVE ACTION
BACK FLOW PREVENTERS CONT.		
<p>RP DEVICE</p> <p>2. Intermittent discharge of water.</p> <p>3. Continuous discharge of water when ventilator is not in a wash cycle.</p> <p>4. Continuous discharge of water out relief valve when ventilator is washing.</p>	<p>A. Intermittent discharge of water through the relief valve is fairly common and usually occurs if there is inlet pressure fluctuations of more than 3 psi and when the solenoid valve closes after a wash cycle.</p> <p>A. Foreign material in the check valve.</p> <p>A. Foreign material in relief valve.</p>	<p>1. No action necessary.</p> <p>1. Leave the inlet hand valve open and close the outlet hand valve. If there is still continuous discharge it indicates that foreign material is preventing the first check valve from closing. If flushing will not clear the unit, remove and clean the first check valve. (Refer to illustration on Page 20)</p> <p>1. Foreign material preventing complete closing of the relief valve. Flushing the relief valve may correct this condition. Repeat procedure if necessary. If flushing does not stop discharge with flow through device, remove and clean relief valve. In no case should the relief valve outlet port be plugged, closed off or restricted.</p>
DRAINS		
<p>1. If during a wash cycle water overflows the gutter and comes out inlet slot.</p>	<p>A. Clogged drain outlet (Note: Each ventilator section has its own drain outlet).</p> <p>B. Drain system clogged (If more than one ventilator system is not draining it indicates that the drain system is clogged).</p> <p>C. Pre-flush line not in drain opening.</p> <p>D. Clogged or full grease trap</p>	<p>1. Reach in through the inlet slot of the ventilator and check to see if foreign material such as rags, paper towels, order chits, etc., have clogged the drain opening.</p> <p>1. A chemical drain cleaner applied as per instructions may dissolve stoppage. Pour cleaner into main grease gutter at drain opening.</p> <p>2. Hire a drain roter service to clear entire system.</p> <p>1. This line is located in the ventilator and runs from the spray manifold to the ventilator drain. Check to make sure that the pre-flush line is aimed into the drain opening so that it purges the drain properly.</p> <p>1. Some cities and counties have codes which require grease traps. If a grease trap is in use, check to ensure that it is not clogged.</p>
MISCELLANEOUS		
<p>1. "Enter Code" displayed on C-6000 Command Center.</p> <p>2. Wrong language displayed on C-6000 Command Center.</p>	<p>1. Enable Code has not been entered at factory.</p> <p>2. "English / Espanol" button has been pressed.</p>	<p>1. Contact Factory.</p> <p>2. Press the "English / Espanol" button to toggle the language displayed between English and Spanish (Espanol).</p>

TROUBLE-SHOOTING

PLC STATUS LIGHT CHARTS

The following is a list of how the status lights will appear on the PLC (Programmable Logic Controller) that is operating correctly.

PLC	X (Inputs)	STANDARD (SINGLE OR SEQUENTIAL WASH) DESCRIPTION - PLC
	0	On while "Fire Test Switch" is pushed and <u>held</u> , or hood is in Internal Fire Mode. Off during "Cool Down Cycle"
	1	On when Remote Fire Switch is activated, or when hood is in External Fire Mode.
	2	On normally. It shuts off if cabinet is equipped with Low Detergent alert feature and the detergent is low.
	3	Off normally. On when Jumper is installed to disable Wash Solenoids from opening during Internal Fire Mode and External Fire Modes.
	4	Wash permission signal (if so equipped)
	5	Not Used
	6	Not Used
	7	Not Used
	Y (Outputs)	STANDARD (SINGLE OR SEQUENTIAL WASH) DESCRIPTION - PLC
	0	On when Wash Solenoid # 1 should be open.
	1	On during an Internal or External Fire Mode. On during "Cool Down Cycle".
	2	On when Detergent Pump should be on.
	3	On when Exhaust Fan should be on.
	COM	Never comes on
	4	On when Supply Fan should be on.
	COM	Never comes on
5	On when damper is in "Wash" position, or while damper is moving to "Wash" position	

EXPANSION MODULE SEQUENTIAL "S2-S5"	Y (Outputs)	(SEQUENTIAL WASH "S2-S5") DESCRIPTION - EXPANSION MODULE
	0	On when Wash Solenoid # 2 should be open.
	1	On when Wash Solenoid # 3 should be open.
	2	On when Wash Solenoid # 4 should be open.
	3	On when Wash Solenoid # 5 should be open.
	4	Not Used
	5	Not Used
	6	Not Used
	7	Not Used

TROUBLE-SHOOTING

C-6000, C-6000-A and C-6000-B Terminal Voltages (See page no. 25 to determine which model is present)

TERMINAL	DESCRIPTION	FAN OFF	FAN ON	WASH ON	INT. FIRE	EXT. FIRE
L1	Main Power Connection : Hot	120 VAC	120 VAC	120 VAC	120 VAC	120 VAC
L2	Main Power Connection : Neutral	Common				
1	Output to Supply Fan Motor Starter	0 VAC	120 VAC	0 VAC	0 VAC	0 VAC
2	Output to Detergent Pump	0 VAC	0 VAC	120 VAC	0 VAC	0 VAC
3	Thermostat Return	0 VAC	0 VAC	0 VAC	24 VAC	0 VAC
4	Fused Supply to PLC Outputs & Etc.	120 VAC	120 VAC	120 VAC	120 VAC	120 VAC
5	120 VAC Neutral Leg	High Voltage Common				
8	Output to Exhaust Fan Motor Starter	0 VAC	120 VAC	0 VAC	0 VAC	120 VAC
CM	Output to Cold Water Mist Solenoid	0 VAC	120 VAC	0 VAC	0 VAC	120 VAC
9	Output to Wash Solenoid Valve #1	0 VAC	0 VAC	120 VAC	120 VAC	120 VAC
10	Output to Wash Solenoid Valve #2	0 VAC	0 VAC	120 VAC	120 VAC	120 VAC
11	Output to Wash Solenoid Valve #3	0 VAC	0 VAC	120 VAC	120 VAC	120 VAC
12	Output to Wash Solenoid Valve #4	0 VAC	0 VAC	120 VAC	120 VAC	120 VAC
13	Output to Wash Solenoid Valve #5	0 VAC	0 VAC	120 VAC	120 VAC	120 VAC
SF1 SF2	N.O. Dry Contacts for Supply Fan Remote Control Center	Open	Closed	Open	Open	Open
EF1 EF2	N.O. Dry Contacts for Exhaust Fan Remote Control Center	Open	Closed	Open	Open	Closed
A1 A2	N.O. Dry Contacts for Interface to Building Fire Alarm / Monitor System	Open	Open	Open	Closed	Closed
Q1 Q2	N.C. Dry Contacts for Interface to Fire System Fuel Shutoff Control	Closed	Closed	Closed	Open	Open
FS	Input from Remote Fire Switch	0 VAC	0 VAC	0 VAC	0 VAC	120 VAC
(1) LD	Input from Detergent Flow Switch	NO Low Detergent Sensor (Jumper J1 is present)				
		120 VAC	120 VAC	120 VAC	120 VAC	120 VAC
(2) LD	Input from Detergent Flow Switch	Low Detergent Sensor (Jumper J1 is cut or NOT present)				
		0 VAC	0 VAC	0 VAC	0 VAC	0 VAC
GX	Power for GX2 Damper Actuators	0 VAC	24 VAC	0 VAC	0 VAC	24 VAC
15	Output to Thermostat(s)	24 VAC	24 VAC	24 VAC	24 VAC	24 VAC
17	24 VAC Common	Low Voltage Common				
18	CG3 Damper Drive Signal [1-10]	C-6000 or C-6000-A				
		14 VDC	6 VDC	14 VDC	6 VDC	6VDC
18	CG3 Damper Drive Signal	C-6000-B				
		24 VAC	0 VAC	24 VAC	0 VAC	0 VAC
19	Power for CG3 Damper Actuators	24 VAC	24 VAC	24 VAC	0 VAC	24 VAC
(3) 20	CG3 Damper Drive Signal [11-20]	14 VDC	6 VDC	14 VDC	6 VDC	6VDC
GXT	Thermostat Return for GX2 Hoods	24 VAC	24 VAC	24 VAC	24 VAC	24 VAC

(1) 120 VAC - A jumper is installed between LD and #4 or Jumper J1 is present (No LD/Detergent Flow Switch Present)

(2) 120 VAC - LD (Detergent Flow Switch) is installed and Detergent Pump is running and Detergent is present
0 VAC - LD (Detergent Flow Switch) is installed and Detergent Pump is running and Detergent is NOT present

(3) #20 is only present on the C-6000-A control
#20 only has voltage when there are 2 Damper Positioners present (C-6000-20), otherwise voltage is 0 VAC

MODEL C-6000 OR C-6000-A SERIES CONTROL

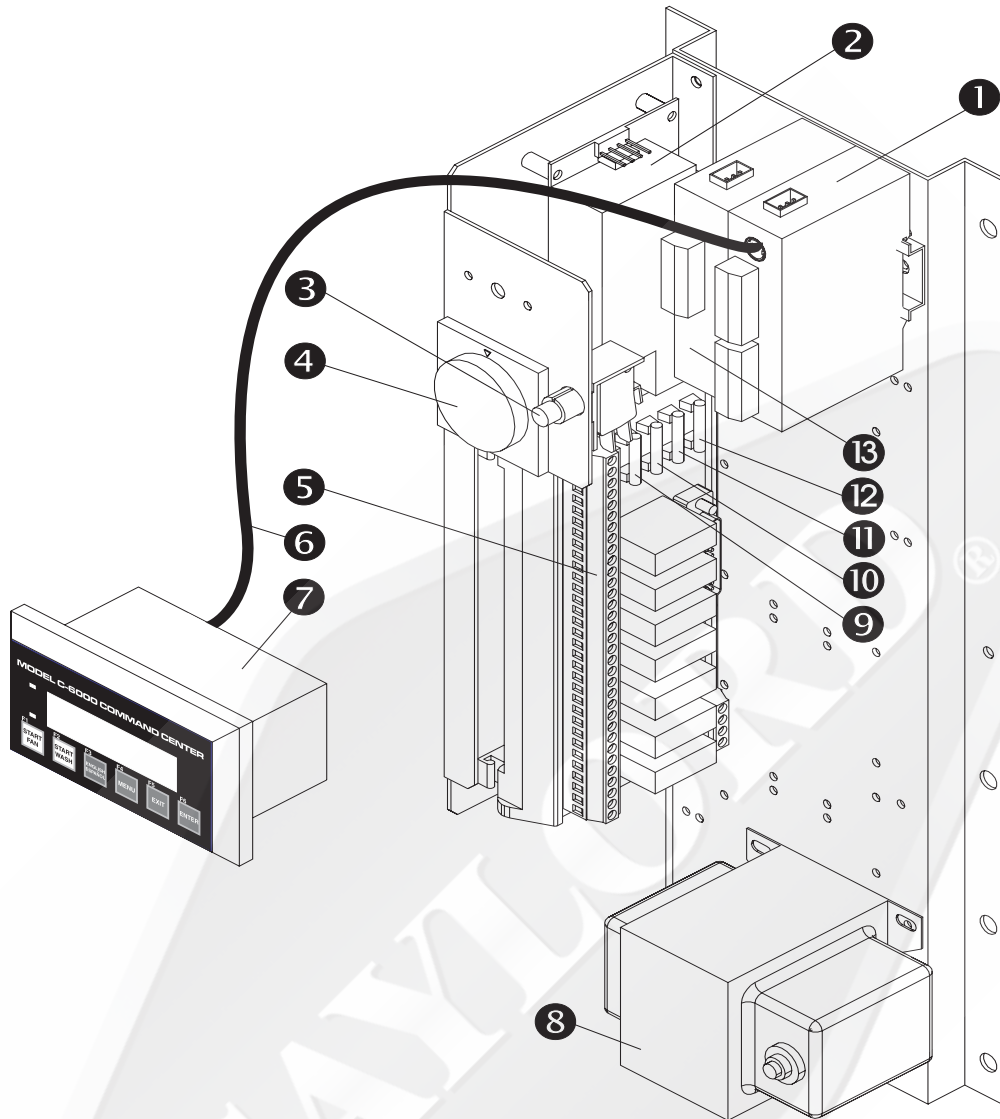

PC. NO.	DESCRIPTION	GAYLORD PART NO.	MFG PART NO.
1	Programmable Logic Controller (PLC) w/ Program	75634	
2	24VDC Power Supply	18863	
3	Fire Test Switch	16894	
4	Damper Positioner	18876	
5	Output Module	18779	
6	PLC to Operator Interface Cable	18868	
7	Operator Interface	75636	
8	100 VA Transformer	18861	
9	Fuse (F1) - 2 Amp 24VDC Power Supply	13062	BUSS AGC-2
10	Fuse (F2) - 4 Amp PLC - 120 VAC	10039	BUSS AGC-4
11	Fuse (F3) - 1 Amp Supply Fan Mag. Starter	19027	BUSS MDL-1
12	Fuse (F4) - 1 Amp Exhaust Fan Mag. Starter	19027	BUSS MDL-1
13	Expansion Module (Optional - used for S2-S5)	18867	
14	Flash Guard (Not Shown)	18877	

MODEL C-6000-B SERIES CONTROL

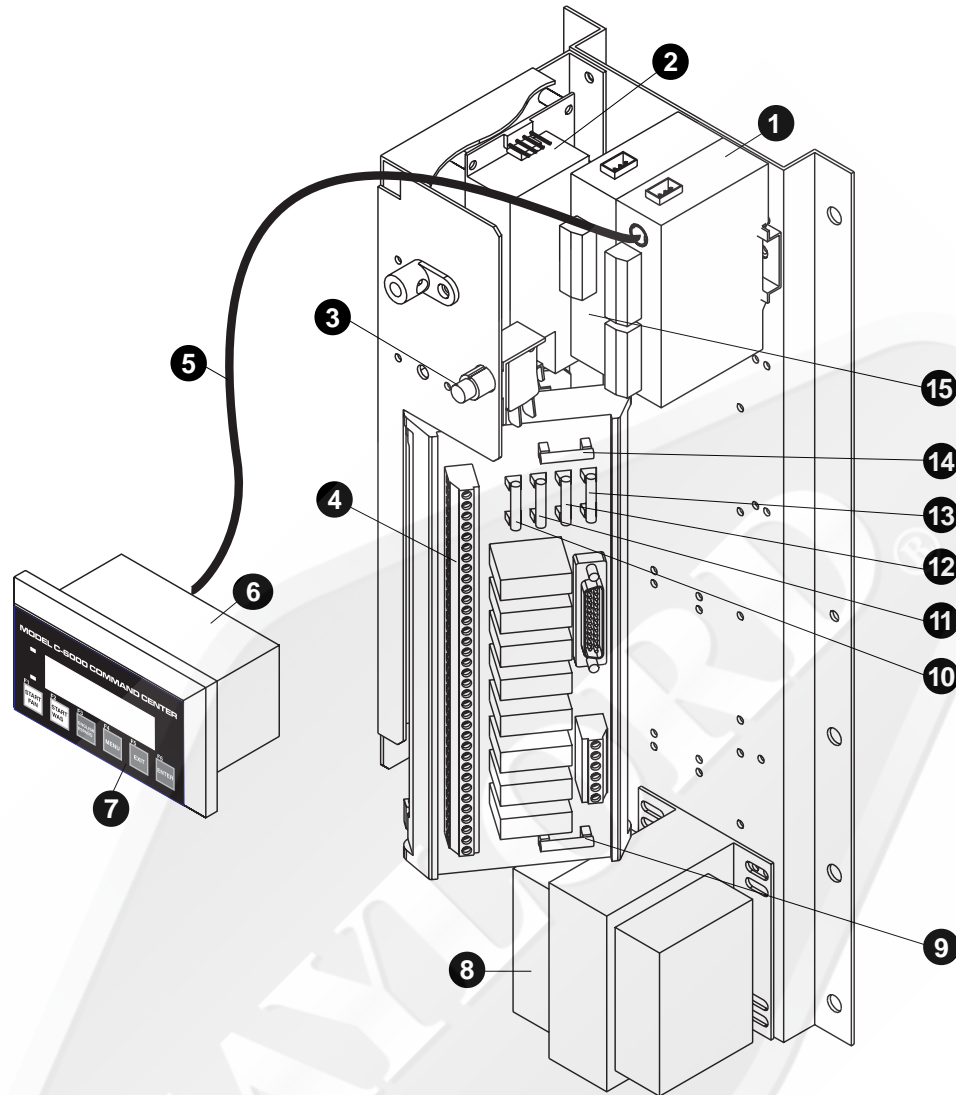

**C-6000-ESP-S Component Schedule
(1-3 Transformers/High Voltage Power Supplies)**

PC. NO.	DESCRIPTION	GAYLORD PART NO.	
1	Programmable Logic Controller (PLC) w/ Program	75634	
*	2	Expansion Module	18866
	3	24VDC Power Supply	18863
	4	Fuse (F7) - Size Varies	
	5	Fire Test Switch	16894
	6	C-6000-B Output Module	18983
	7	PLC to Operator Interface Cable	18868
	8	Operator Interface w/program & Mylar label	75871
	9	Operator Interface Mylar Label	19010
	10	100 VA Transformer [C-6000-10]	18981
	11	Control Relay - SPDT (CR9) ESP Fire Signal	11399
		Socket - SPDT 11, 12, 13, 14, 17, 18, 20	11413
	12	Control Relay - SPDT (CR10)	11399
		Socket - SPDT	11413
	13	Control Relay - SPDT (CR11)	11399
		Socket - SPDT	11413
	14	Control Relay - SPDT (CR12)	11399

DAMPER CONTROL MOTOR AND CG3-FDL WIRING

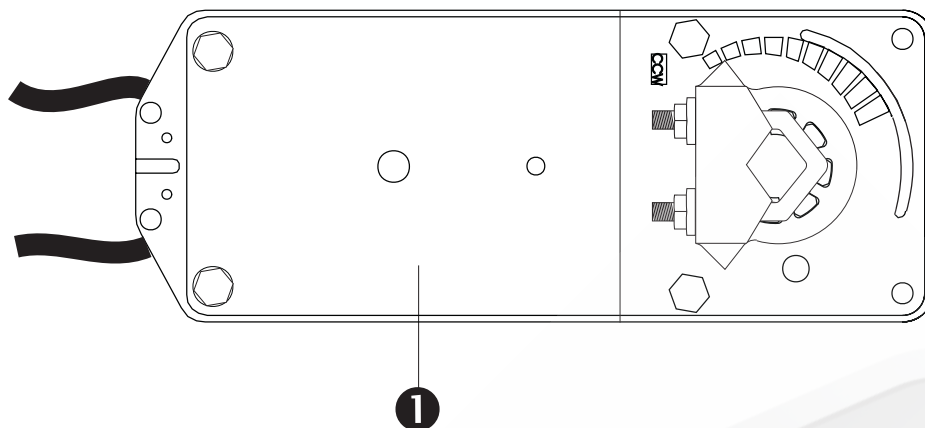

Used in CG3, CG3-FDL, and CG3-FDT only

PC. NO.	DESCRIPTION	GAYLORD PART NO.
1	For C-6000 or C-6000-A: Damper Control Motor - AF24-SR (24 Volt) -----	30204
1	For C-6000-B: Damper Control Motor - AF24-MFT P-10050 (24 Volt) ----- or AF24-MFT S-0001 (24 Volt) -----	18979

CG3-FDL WIRING NOTES

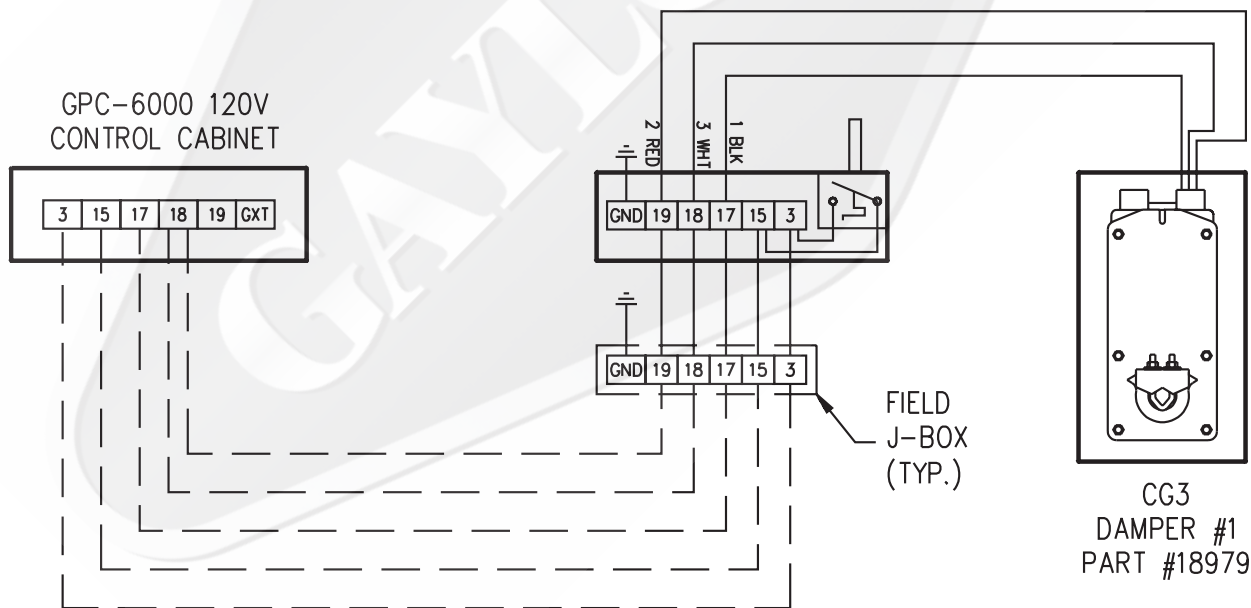

CG3-FDL WIRING NOTES w/C-6000-B:

1. ADD FIRE DAMPER LOCKOUT BRACKET, "FDL" BRACKET, TO DAMPER ON VENTILATOR
2. WIRE #'S 18 & 19 FROM VENTILATOR CONNECT TO #18 IN THE GPC-6000 CONTROL CABINET.

DETERGENT PUMP

DETERGENT PUMP
MODEL NUMBER VF-100P-60B

ITEM.	PART NUMBER	ITEM.	PART NUMBER
MOTOR COVER.....	10226	YOKE AND BEARING ASSEMBLY.....	10237
ELECTRICAL "J" BOX.....	N/A	PUSH BUTTON TEST SWITCH.....	10238
COVER MOUNTING SCREWS.....	N/A	CAM #1.....	10254
MOTOR MOUNTING SCREWS.....	N/A	CAM #2.....	10255
ARMATURE BEARING.....	10231	CAM #3.....	10256
COIL (115 VOLT).....	10232	CAM #4.....	10257
COIL (220 VOLT).....	10259	SCREWS FOUR REQUIRED.....	10239
ARMATURE.....	10233	DIAPHRAGM.....	10240
ARMATURE SPACER.....	10234	BRASS OUTLET.....	10242
GEAR BOX ASSEMBLY.....	10253	*TOP CAP.....	10244
BRACKET.....	10236	SPRING.....	10246
SET SCREW.....	10237	PUMP HEAD (Complete with all fittings).....	10247
		POPPET CHECK.....	10250
		"O" RING.....	10251
		COMPLETE PUMP HEAD/FOOT VALVE KIT.....	10275
		MOUNTING SCREW(Head)Four required....	10248
		TUBE NUT (1/4").....	10268
		ADAPTER WITH "O"RING.....	10260
		BRASS DETURGENT INLET Check valve....	10265
		SPRING.....	10266
		TUBE NUT.....	10261
		FOOT VALVE(Complete).....	10269
		ALLEN WRENCH(1/16").....	10271
		VINYL TUBING.....	10272
		COPPER TUBING(1/4").....	10273

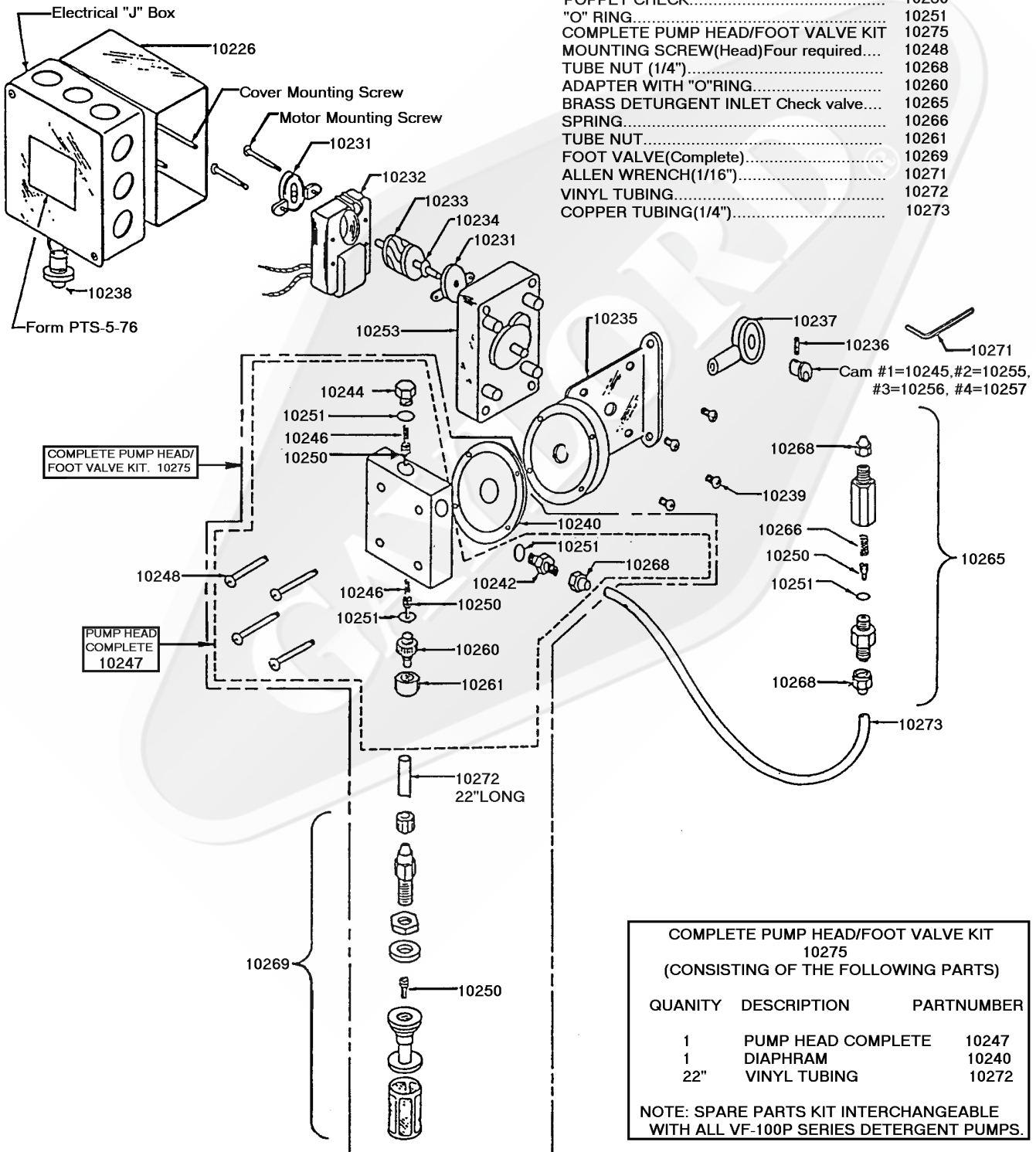

MISCELLANEOUS VENTILATOR PARTS

GAYLORD PART NO.	DESCRIPTION	ILLUSTRATION
<p>SPRAY NOZZLES</p> <p>10303 Single Head 10304 Double Head 10305 High Volume (Single Head)</p>		
<p>15330</p> <p>COLD WATER MIST NOZZLES</p>		
<p>10308 10309</p> <p>VENTILATOR & CONTROL CABINET DOOR HANDLES</p> <p>A. Handle Complete B. Tongue Only</p>		
<p>10119</p> <p>LIGHT GLOBE</p> <p>Kason</p>		
<p>13211</p> <p>INCANDESCENT LIGHT LENS & FRAME</p> <p>12" x 12" Recessed Light Lens & Retainer</p>		
<p>13210 10111 10112</p> <p>FLUORESCENT LIGHT LENS & FRAME</p> <p>2 Ft. Recessed Light Lens & Retainer 3 Ft. Recessed Light Lens & Retainer 4 Ft. Recessed Light Lens & Retainer</p>		
<p>18465 18466</p> <p>EXHAUST DUCT THERMOSTATS</p> <p>12" Length 250°F 15" Length 250°F</p>		
<p>10321</p> <p>165°F SUPPLY DUCT FIRE DAMPER FUZE LINK</p>		
<p>10323</p> <p>For CG3-FDD and CG3-FDT 280°F EXHAUST DUCT FIRE DAMPER FUZE LINK</p>		

WIRING DIAGRAM FOR MODEL C-6000-10

120 VOLT

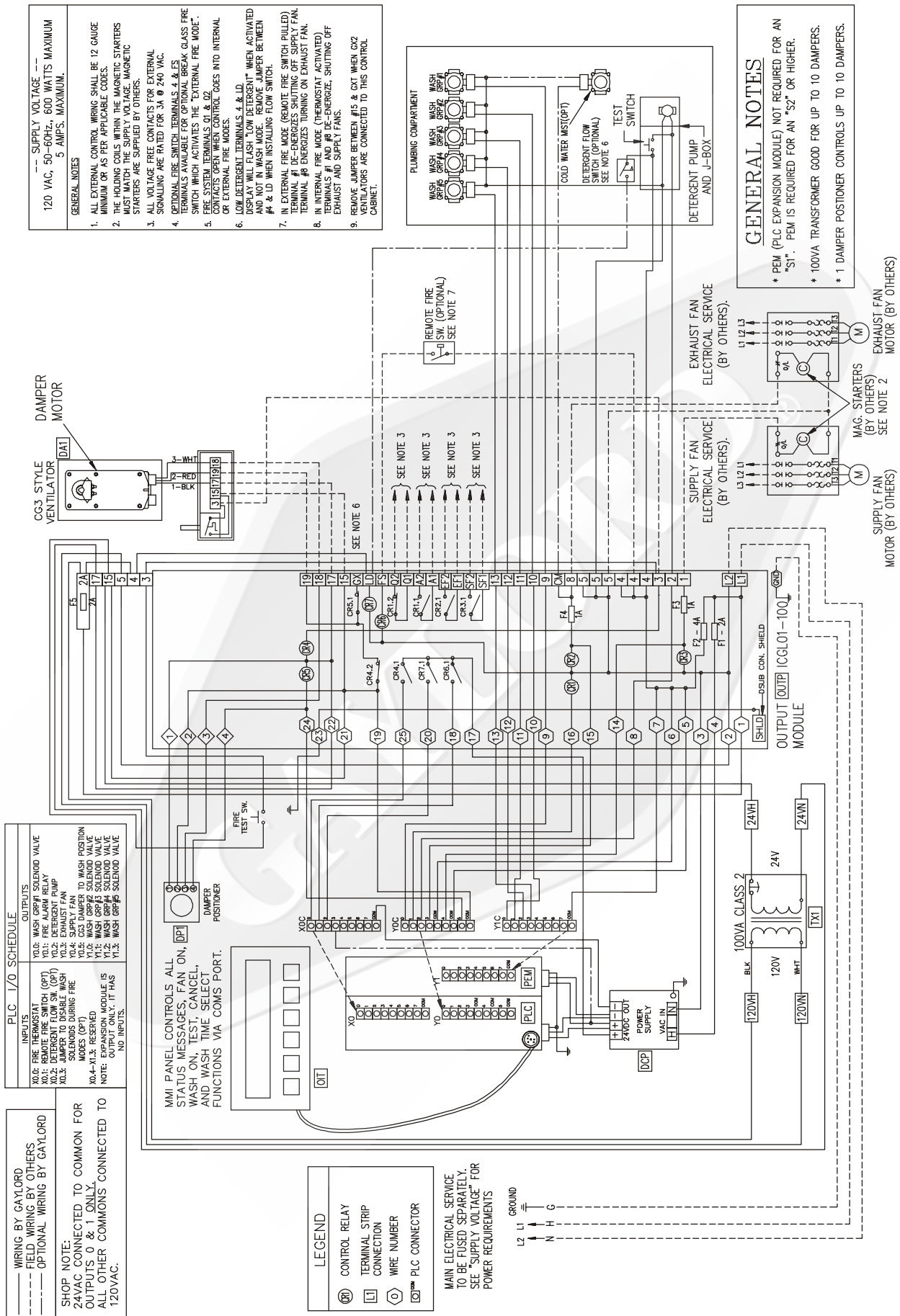

WIRING DIAGRAM FOR MODEL C-6000-10-A

120 VOLT

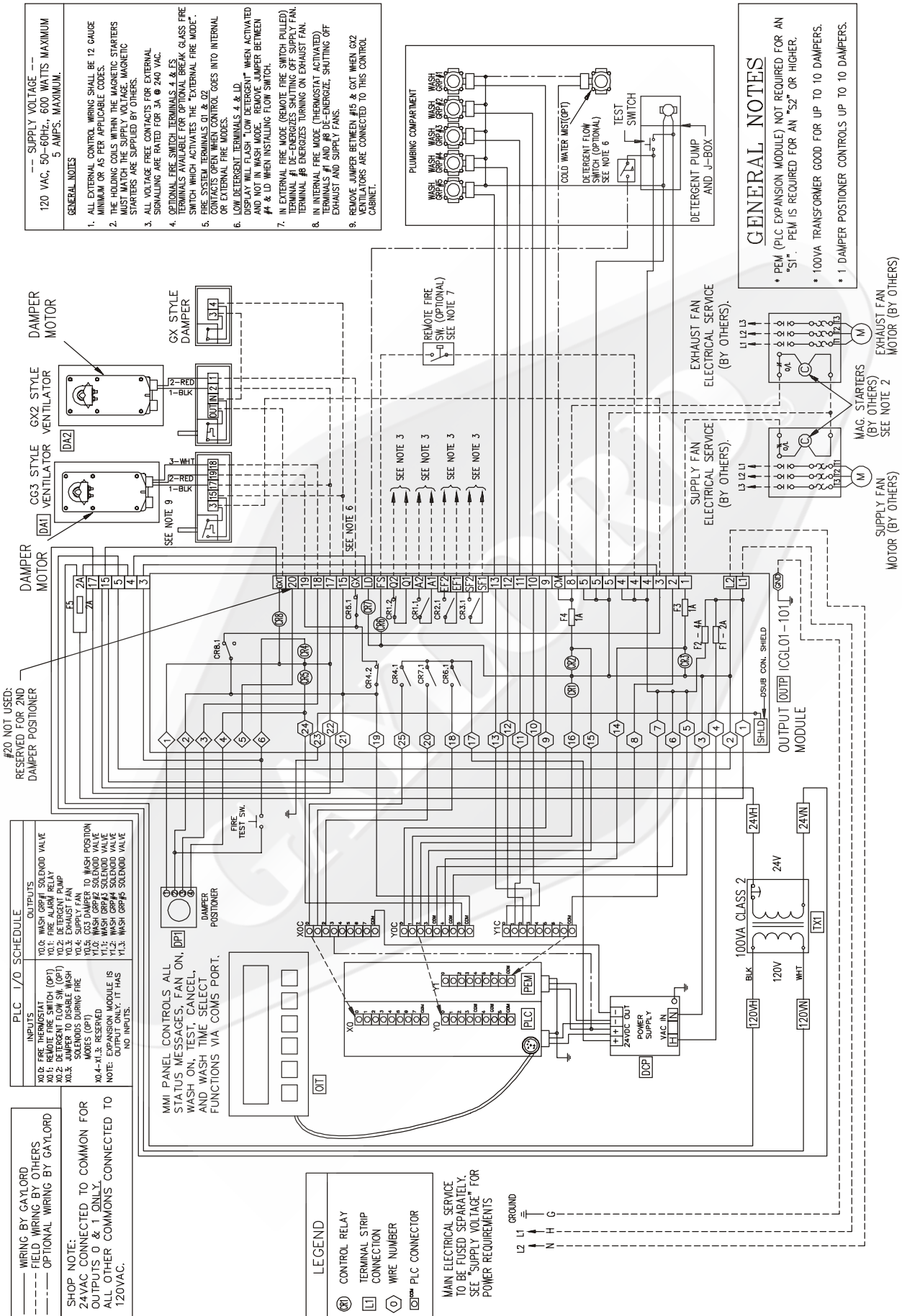

WIRING DIAGRAM FOR MODEL C-6000-10-A

220 VOLT

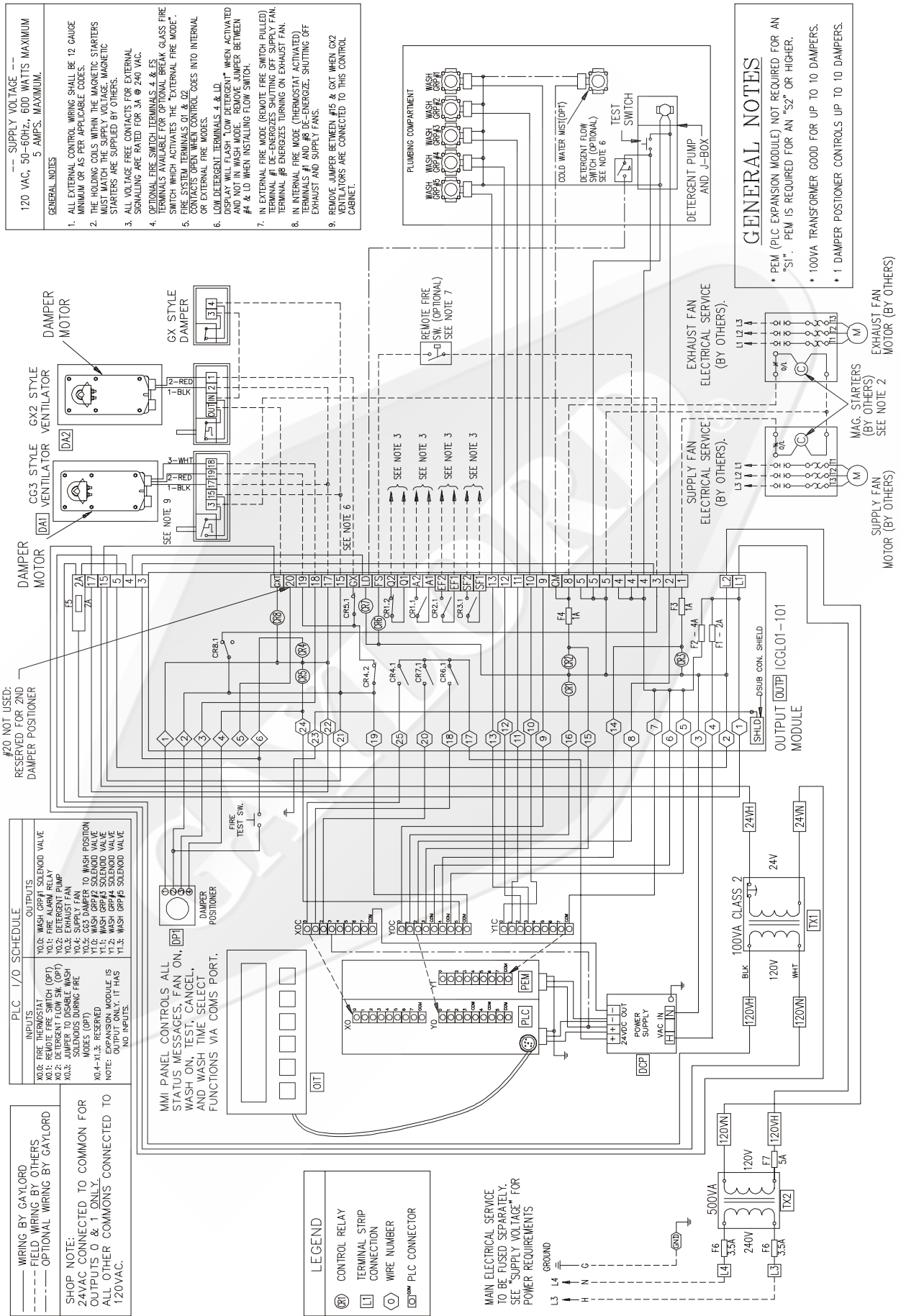

120 VAC, 50-60HZ, 600 WATTS MAXIMUM
5 AMPS. MAXIMUM.

GENERAL NOTES

- ALL EXTERNAL CONTROL WIRING SHALL BE 12 GAUGE MINIMUM OR AS PER APPLICABLE CODES.
- THE HOLDING COILS WITHIN THE MAGNETIC STARTERS MUST HAVE COILS OF THE CORRECT MAGNETIC STARTERS ARE SUPPLIED BY OTHERS.
- ALL VOLTAGE FREE CONTACTS FOR EXTERNAL SIGNALING ARE RATED FOR 3A @ 240 VAC.
- OPTIONAL FIRE SWITCH TERMINALS 4 & E5 TERMINALS AVAILABLE FOR OPTIONAL BREAK GLASS FIRE SWITCH WHICH ACTIVATES THE "EXTERNAL FIRE MODE".
- CONTACTS OPEN WHEN CONTROL COILS INTO INTERNAL OR EXTERNAL FIRE MODES.
- LOW DETERGENT TERMINALS 4 & LD DISPLAY WILL FLASH "LOW DETERGENT" WHEN ACTIVATED AND NOT IN WASH MODE. REMOVE JUMPER BETWEEN #4 & LD WHEN INSTALLING FLOW SWITCH.
- IN EXTERNAL FIRE MODE (REMOTE FIRE SWITCH PULLED) TERMINAL #1 DE-ENERGIZES SHUTTING OFF SUPPLY FAN. TERMINAL #6 ENERGIZES TURNING ON EXHAUST FAN. TERMINALS #1 AND #6 DE-ENERGIZE, SHUTTING OFF EXHAUST AND SUPPLY FANS.
- REMOVE JUMPER BETWEEN #15 & GAT WHEN GX2 VENTILATORS ARE CONNECTED TO THIS CONTROL CABINET.

GENERAL NOTES

- * PEM (PLC EXPANSION MODULE) NOT REQUIRED FOR AN "S1". PEM IS REQUIRED FOR AN "S2" OR HIGHER.
- * 100VA TRANSFORMER GOOD FOR UP TO 10 DAMPERS.
- * 1 DAMPER POSITIONER CONTROLS UP TO 10 DAMPERS.

PLC I/O SCHEDULE

INPUTS:

- X0.0: FIRE THERMOSTAT
- X0.1: REMOTE FIRE SWITCH (OPT)
- X0.2: JUMPER TO DISABLE WASH MODES (OPT)
- X0.3: SOLENOID DURING FIRE
- X0.4-X1.3: RESERVED

OUTPUTS:

- Y0.0: WASH CRP#1 SOLENOID VALVE
- Y0.1: FIRE ALARM RELAY
- Y0.2: DETERGENT PUMP
- Y0.3: SUPPLY FAN
- Y0.4: CG3 DAMPER TO WASH POSITION
- Y0.5: CG2 DAMPER TO WASH POSITION
- Y1.0: WASH CRP#2 SOLENOID VALVE
- Y1.1: WASH CRP#3 SOLENOID VALVE
- Y1.2: WASH CRP#4 SOLENOID VALVE
- Y1.3: WASH CRP#5 SOLENOID VALVE

NOTE: EXPANSION MODULE IS OUTPUT ONLY. IT HAS NO INPUTS.

SHOP NOTE:

24VAC CONNECTED TO COMMON FOR OUTPUTS 0 & 1 ONLY. ALL OTHER COMMONS CONNECTED TO 120VAC.

LEGEND

- ⊗ CONTROL RELAY
- ⊞ TERMINAL STRIP CONNECTION
- ◇ WIPE NUMBER
- ⊞ PLC CONNECTOR

MAIN ELECTRICAL SERVICE TO BE FUSED SEPARATELY. SEE "SUPPLY VOLTAGE" FOR POWER REQUIREMENTS

L3 L4 GROUND

H N G

WIRING DIAGRAM FOR MODEL C-6000-20-B

120 VOLT

- SUPPLY VOLTAGE ---
120 VAC, 50-60HZ, 600 WATTS MAXIMUM
5 AMPS, MAXIMUM.
- GENERAL NOTES**
1. ALL EXTERNAL CONTROL WIRING SHALL BE 12 GAUGE MINIMUM OR AS PER APPLICABLE CODES.
 2. THE HOUSING COILS WITHIN THE MAGNETIC STARTERS MUST MATCH THE SUPPLY VOLTAGE. MAGNETIC STARTERS ARE SUPPLIED BY OTHERS.
 3. ALL VOLTAGE FREE CONTACTS FOR EXTERNAL SIGNALING ARE RATED FOR 3A @ 240 VAC.
 4. FIRE SWITCH TERMINALS 4 & F5 TERMINALS FOR NORMALLY OPEN FIRE SUPPRESSION MICROSWITCH AND/OR REMOTE FIRE SWITCH WHICH ACTIVATES THE "EXTERNAL FIRE MODE".
 5. FIRE SYSTEM TERMINALS O1 & O2 CONTACTS OPEN WHEN CONTROL GOES INTO INTERNAL OR EXTERNAL FIRE MODES.
 6. LOW DETERGENT TERMINALS 4 & LD, DISPLAY WILL FLASH "LOW DETERGENT" WHEN ACTIVATED AND NOT IN WASH MODE. CUT JUMPER (J1), AND REMOVE ANY JUMPER BETWEEN #4 & LD WHEN INSTALLING FLOW SWITCH.
 7. IN EXTERNAL FIRE MODE (REMOTE FIRE SWITCH CONTACTS CLOSED) TERMINAL #1 DE-ENERGIZES SHUTTING OFF SUPPLY FAN, TERMINAL #9 ENERGIZES TURNING ON EXHAUST FAN.
 8. IN INTERNAL FIRE MODE (THERMOSTAT ACTIVATED) TERMINALS #1 AND #8 DE-ENERGIZE, SHUTTING OFF EXHAUST AND SUPPLY FANS.
 9. CUT JUMPER (J2), AND REMOVE ANY JUMPER BETWEEN #15 & GXT WHEN GX2 OR N-97 DAMPER MOTORS ARE CONNECTED TO THIS CONTROL CABINET.

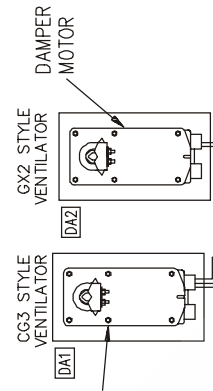

PLC I/O SCHEDULE	
INPUTS	OUTPUTS
X0.0: FIRE THERMOSTAT	Y0.0: WASH GRP#1 SOLENOID VALVE
X0.1: REMOTE FIRE SWITCH (OPT)	Y0.1: FIRE ALARM RELAY
X0.2: DETERGENT FLOW SW. (OPT)	Y0.2: DETERGENT PUMP
X0.3: SUPPLY FAN	Y0.3: EXHAUST FAN
X0.4-X1.3: RESERVED	Y0.4: GX1 DAMPER TO WASH POSITION
X1.0: WASH GRP#2 SOLENOID VALVE	Y1.0: WASH GRP#2 SOLENOID VALVE
X1.1: WASH GRP#3 SOLENOID VALVE	Y1.1: WASH GRP#3 SOLENOID VALVE
X1.2: WASH GRP#4 SOLENOID VALVE	Y1.2: WASH GRP#4 SOLENOID VALVE
X1.3: WASH GRP#5 SOLENOID VALVE	Y1.3: WASH GRP#5 SOLENOID VALVE
NOTE: EXPANSION MODULE IS OUTPUT ONLY. IT HAS NO INPUTS.	

--- WIRING BY GAYLORD
--- FIELD WIRING BY OTHERS
--- OPTIONAL WIRING BY GAYLORD

SHOP NOTE:
24VAC CONNECTED TO COMMON FOR OUTPUTS 0 & 1 ONLY.
ALL OTHER COMMONS CONNECTED TO 120VAC.

MMI PANEL CONTROLS ALL STATUS MESSAGES, FAN ON, WASH ON, TEST, CANCEL, AND WASH TIME SELECT, FUNCTIONS VIA COMS PORT.

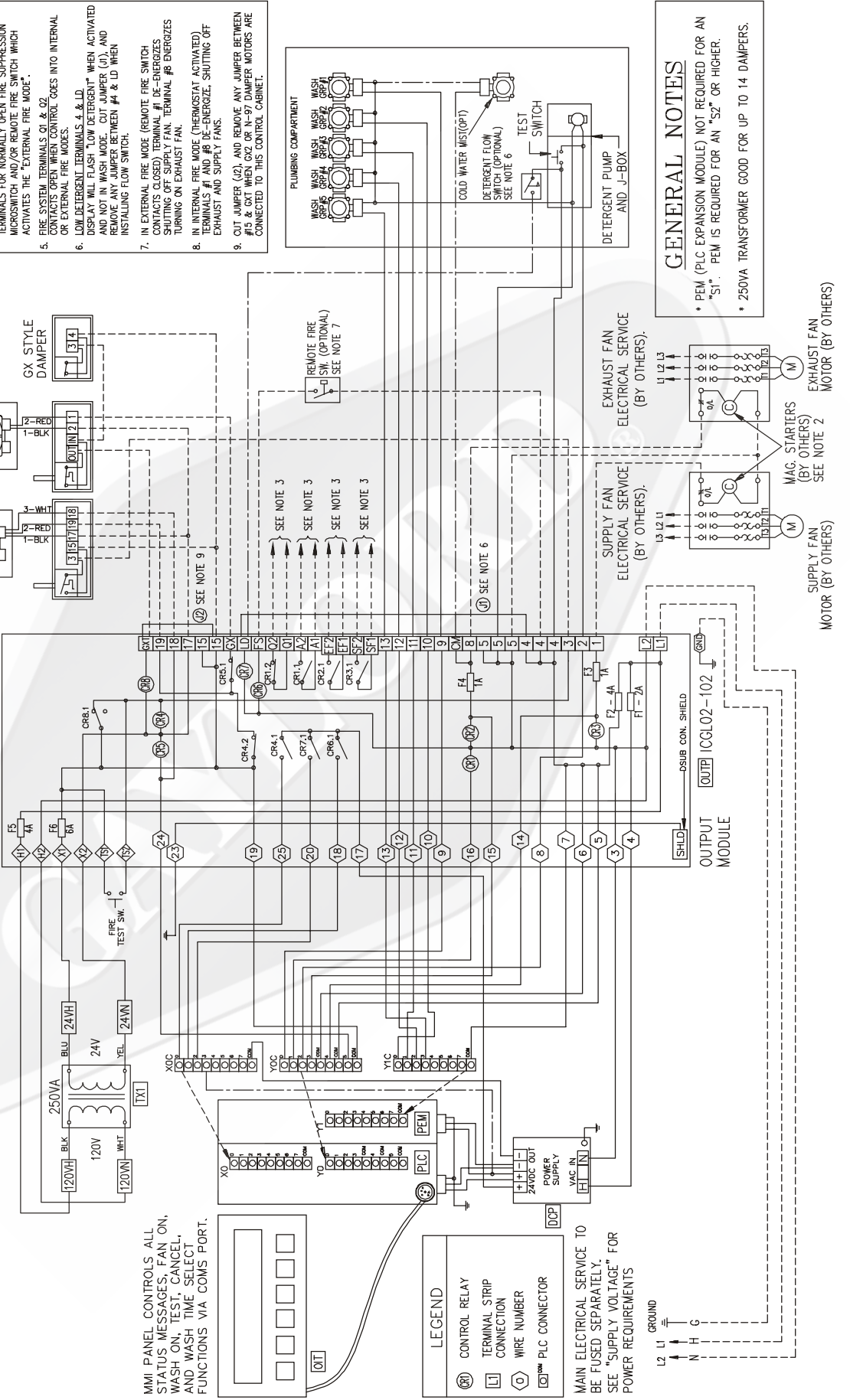

GENERAL NOTES

- PEM (PLC EXPANSION MODULE) NOT REQUIRED FOR AN "S1". PEM IS REQUIRED FOR AN "S2" OR HIGHER.
- 250VA TRANSFORMER GOOD FOR UP TO 14 DAMPERS.

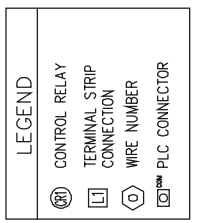

MAIN ELECTRICAL SERVICE TO BE FUSED SEPARATELY. SEE "SUPPLY VOLTAGE" FOR POWER REQUIREMENTS



WIRING DIAGRAM FOR MODEL C-6000-10-B

220 VOLT

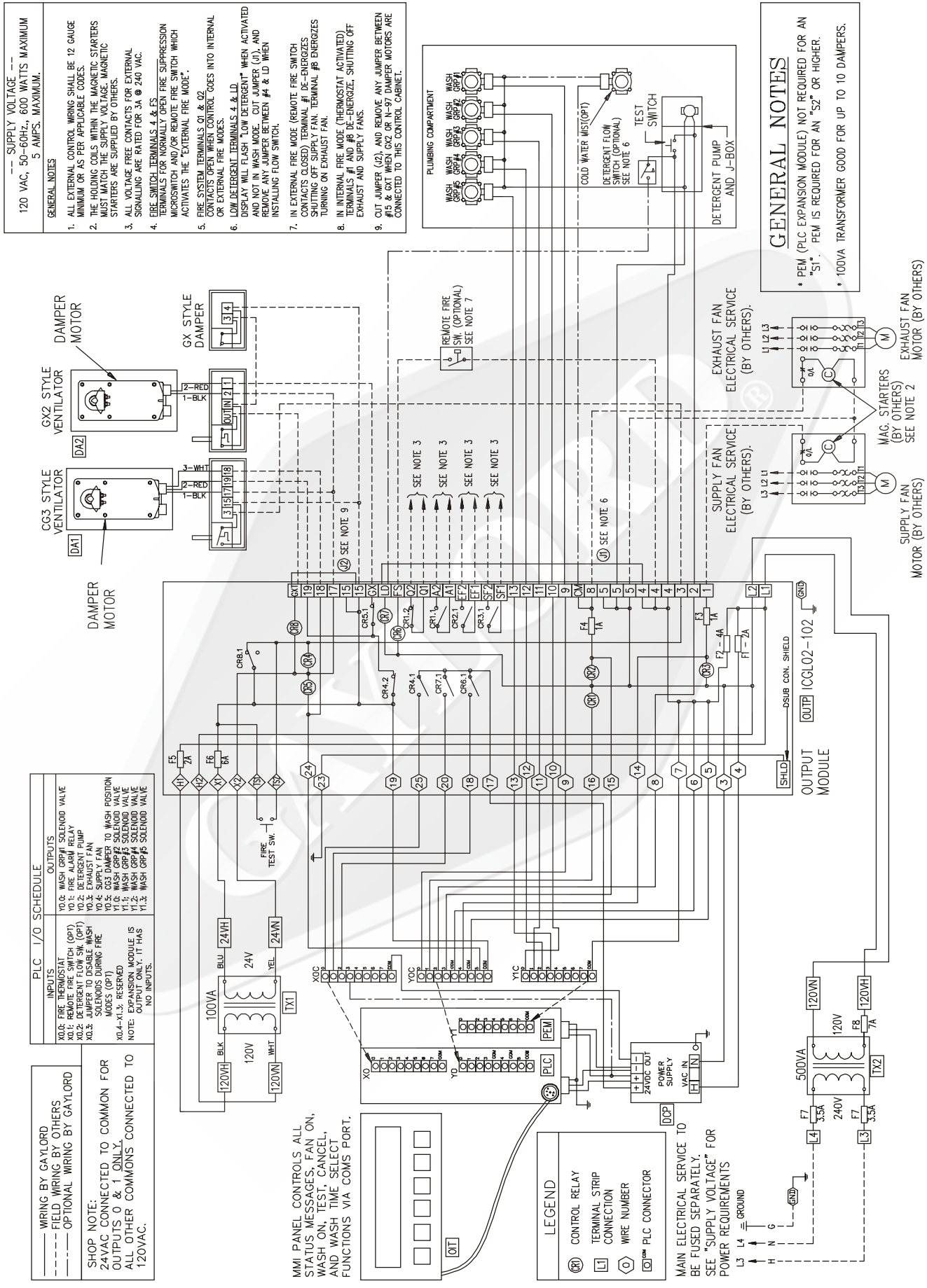

--- SUPPLY VOLTAGE ---
120 VAC, 50-60HZ., 600 WATTS MAXIMUM
5-AMPS. MAXIMUM.

GENERAL NOTES

- ALL EXTERNAL CONTROL WIRING SHALL BE 12 GAUGE MINIMUM OR AS PER APPLICABLE CODES.
- THE HOLDING COILS WITHIN THE MAGNETIC STARTERS MUST MATCH THE SUPPLY VOLTAGE. MAGNETIC STARTERS ARE SUPPLIED BY OTHERS.
- ALL VOLTAGE FREE CONTACTS FOR EXTERNAL SIGNALING ARE RATED FOR 3A @ 240 VAC.
- FIRE SWITCH TERMINALS 4 & FS TERMINALS FOR NORMALLY OPEN FIRE SUPPRESSION MICROSWITCH AND/OR REMOTE FIRE SWITCH WHICH ACTIVATES THE "EXTERNAL FIRE MODE".
- FIRE SYSTEM TERMINALS 01 & 02 CONTACTS OPEN WHEN CONTROL GOES INTO INTERNAL OR EXTERNAL FIRE MODES.
- LOW DETERGENT TERMINALS 4 & LD DISPLAY WILL FLASH "LOW DETERGENT" WHEN ACTIVATED AND NOT IN WASH MODE. CUT JAMPER (U) AND REMOVE ANY JAMPER BETWEEN #4 & LD WHEN INSTALLING FLOW SWITCH.
- IN EXTERNAL FIRE MODE (REMOTE FIRE SWITCH CONTACTS CLOSED) TERMINAL #1 DE-ENERGIZES SHUTTING OFF SUPPLY FAN. TERMINAL #6 ENERGIZES TURNING ON EXHAUST FAN.
- IN INTERNAL FIRE MODE (THERMOSTAT ACTIVATED) TERMINALS #1 AND #6 DE-ENERGIZE, SHUTTING OFF EXHAUST AND SUPPLY FANS.
- CUT JAMPER (U) AND REMOVE ANY JAMPER BETWEEN #15 & CXT WHEN CX2 OR N-97 DAMPER MOTORS ARE CONNECTED TO THIS CONTROL CABINET.

GENERAL NOTES

- PEM (PLC EXPANSION MODULE) NOT REQUIRED FOR AN "S1". PEM IS REQUIRED FOR AN "S2" OR HIGHER.
- 100VA TRANSFORMER GOOD FOR UP TO 10 DAMPERS.

PLC I/O SCHEDULE	
INPUTS	OUTPUTS
X0: FIRE THERMOSTAT	Y0: WASH CRP#1 SOLENOID VALVE
X0.1: REMOTE FIRE SWITCH (OPT)	Y0.1: FIRE ALARM RELAY
X0.2: DETERGENT FLOW SW. (OPT)	Y0.2: DETERGENT PUMP
X0.3: SUPPLY FAN SOLENOID DURING FIRE	Y0.3: SUPPLY FAN
X0.4-X1.3: RESERVED	Y1: WASH POSITION SOLENOID VALVE
	Y1.1: WASH CRP#2 SOLENOID VALVE
	Y1.2: WASH CRP#3 SOLENOID VALVE
	Y1.3: WASH CRP#4 SOLENOID VALVE
	NOTE: EXPANSION MODULE IS OUTPUT ONLY. IT HAS NO INPUTS.

WIRING BY GAYLORD
FIELD WIRING BY OTHERS
OPTIONAL WIRING BY GAYLORD

SHOP NOTE:
24VAC CONNECTED TO COMMON FOR OUTPUTS 0 & 1 ONLY.
ALL OTHER COMMONS CONNECTED TO 120VAC.

MMI PANEL CONTROLS ALL STATUS MESSAGES, FAN ON, WASH ON, TEST, CANCEL, AND WASH TIME SELECT FUNCTIONS VIA COMS PORT.

- LEGEND**
- Ⓜ CONTROL RELAY
 - Ⓛ TERMINAL STRIP CONNECTION
 - Ⓞ WIRE NUMBER
 - Ⓛ PLC CONNECTOR

MAIN ELECTRICAL SERVICE TO BE FUSED SEPARATELY. SEE "SUPPLY VOLTAGE" FOR POWER REQUIREMENTS

L3 L4 = GROUND
H N 0

WIRING DIAGRAM FOR MODEL C-6000-20-B

220 VOLT

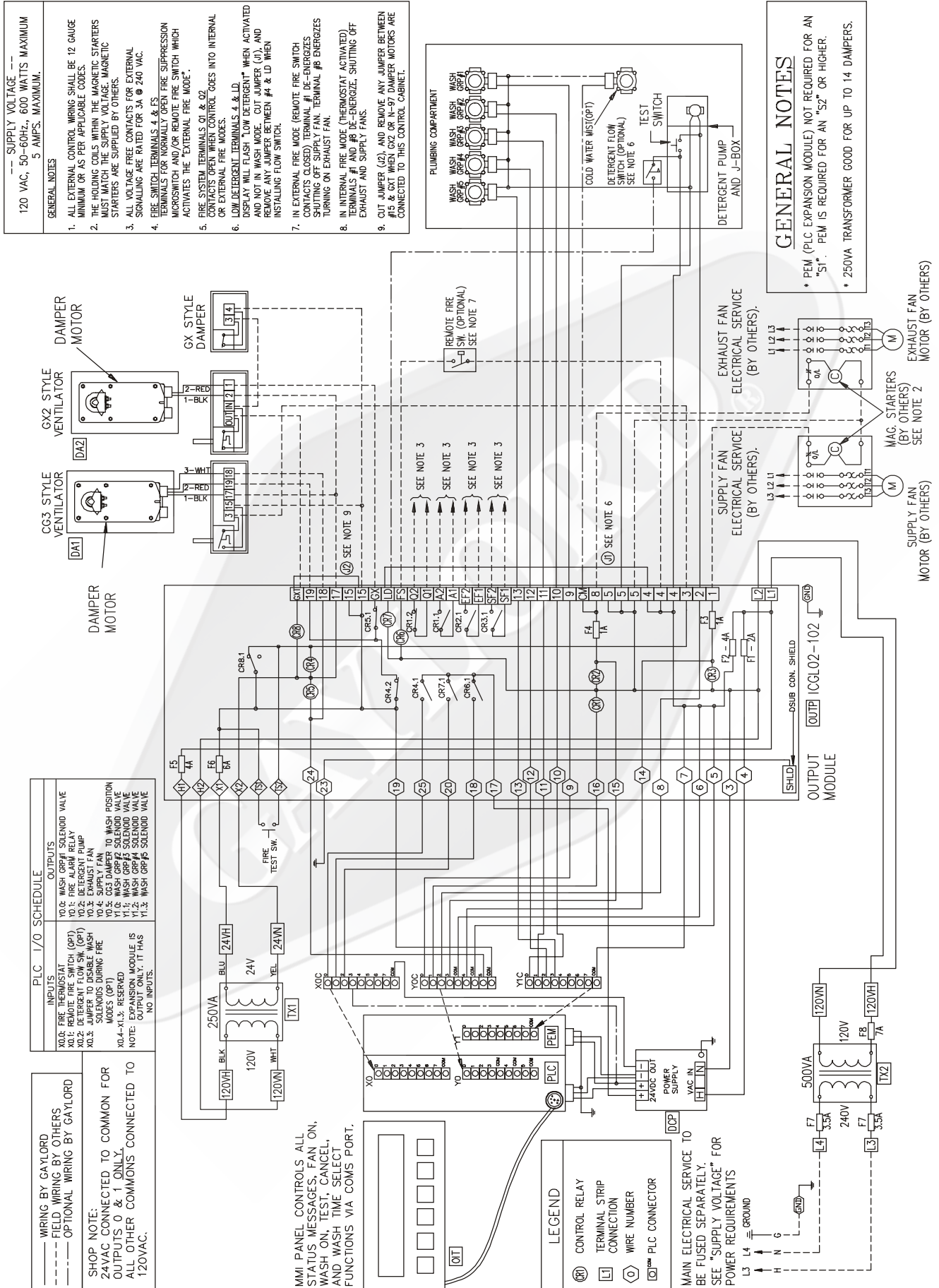

STANDARD VENTILATOR MODELS

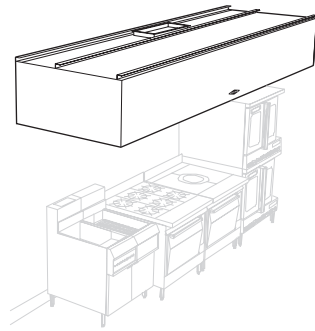

Model CG3-BDL

Application - Wall mounted canopy style for all types of equipment.

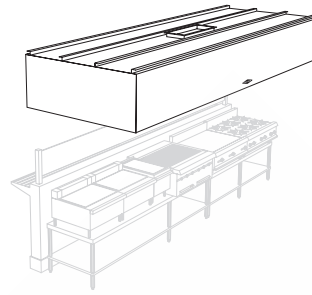

Model CG3-BDL-CL

Application - For single island arrangements

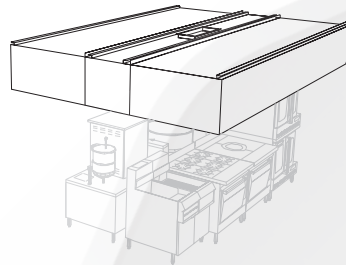

Model CG3-BDL-DS

Application - For island style cooking arrangements where one side of the cooking line is light duty equipment and the other side medium duty equipment.

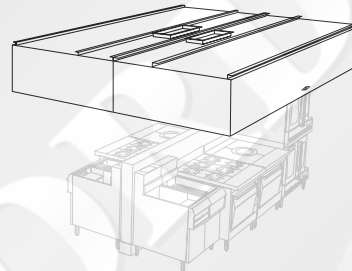

Model CG3-BDL-BB

Application - For island style cooking arrangements over all duties of equipment.

STANDARD MAKE-UP AIR OPTIONS

The make-up air options shown below are available on all BDL Series Ventilators. Except the MAI Series is not available on the CG3-BDL-CL.

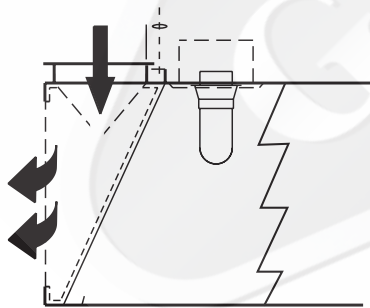

MODEL "MAW" SERIES
FRONT FACE DISCHARGE

This method of introducing make-up air into the kitchen is flexible and has many advantages. Make-up air is discharged through stainless steel perforated panels as illustrated (MAW Series) or optional registers. Typical supply volume is 80% of the exhaust or more, depending on air balance desired. Supply air temperatures should range from 60 to 65°F (16 to 18°C), but may be as low as 50°F (10°C) depending on air volume, distribution, and internal heat load.

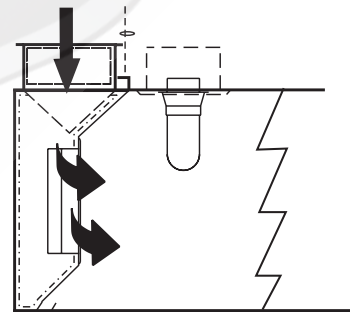

MODEL "MAI" SERIES
INTERNAL DISCHARGE

This method of introducing air into the hood is typically referred to as the "short circuit" method. This design has very limited applications and the amount of supply air able to be introduced varies considerably with the type of cooking equipment. This air may be untempered air in most areas depending upon climatic conditions and the type of cooking equipment. The difference between the quantity of air being introduced and the amount of air being exhausted must be supplied through a traditional make-up air system.

METRIC CONVERSION CHART

DIMENSIONS (Feet and Inches)		
TO CONVERT	TO	MULTIPLY BY
in	mm	25.4
in	cm	2.54
mm	in	0.03937
cm	in	0.3937
ft	cm	30.48
ft	m	0.3048
cm	ft	0.0328
m	ft	3.2808
STANDARD CONVERSIONS		
One meter =	10 dm	one in. = 25.40 mm
One meter =	100 cm	one ft. = 304.80 mm
One meter =	1000 mm	
AIR VELOCITY		
TO CONVERT	TO	MULTIPLY BY
FPM	m/s	0.00508
m/s	FPM	196.85
AIR VOLUME		
TO CONVERT	TO	MULTIPLY BY
CFM	m ³ /sec	0.000472
CFM	m ³ /min	0.02832
CFM	m ³ /hr	1.70
CFM	Ltrs/sec	0.472
m ³ /sec	CFM	2118.88
m ³ /min	CFM	35.31
m ³ /hr	CFM	0.5886
STATIC PRESSURE		
TO CONVERT	TO	MULTIPLY BY
in. W.G.	N/m ²	248.84
N/m ²	in. W.G.	0.004
STANDARD CONVERSIONS		
1.00" W.G. =	248.84	N/m ²
	or 248.84	Pascals (Pa)
	or 2.49	Millibars
1.33" W.G. =	331 N/m ²	or 331 Pa
1.50" W.G. =	373 N/m ²	or 373 Pa
1.65" W.G. =	411 N/m ²	or 411 Pa
1.70" W.G. =	423 N/m ²	or 423 Pa

WATER FLOW/VOLUME		
TO CONVERT	TO	MULTIPLY BY
U.S. ounce	Liters	0.2958
U.S. gal	Liters	3.785
Liters	U.S. gal	0.2642
GPM	L/s	0.0631
L/s	GPM	15.850
STANDARD CONVERSIONS		
one U.S. gal.	=	3.785 Liters
one Liter	=	0.2642 U.S. Gal.
one GPM/ft.	=	0.063 L/s/ft.
	or	0.207 L/s/m
one U.S. gal.	=	0.833 Imperial Gal.
one Imperial Gal.	=	4.546 Liters
WATER PRESSURE		
TO CONVERT	TO	MULTIPLY BY
psi	kg/m ²	703.1
psi	kg/cm ²	0.0703
kg/m ²	psi	0.0014
kg/cm ²	psi	14.223
STANDARD CONVERSIONS		
40 psi =	2.8 kg/cm ²	80 psi = 5.6 kg/cm ²
	= 275.8 Kpa	= 551.6 Kpa
	= 2.758 BAR	= 5.516 BAR
TEMPERATURE		
TO CONVERT	TO	USE FORMULA
°C	°F	°F = (°C • 1.8) + 32
°F	°C	°C = (°F - 32) / 1.8
STANDARD CONVERSIONS		
140°F. to 180°F. =	60°C. to 82°C.	
WEIGHT		
TO CONVERT	TO	MULTIPLY BY
lbs.	N	4.448
lbs.	kg	0.4536
N	lbs	0.2248
kg	lbs	2.2046
PIPE SIZE		
U.S. STANDARD PIPE SIZES	STANDARD METRIC EQUIVALENT PIPE SIZE	
1/2"	=	15 mm
3/4"	=	20 mm
1"	=	25 mm
1-1/4"	=	32 mm
1-1/2"	=	40 mm
2"	=	50 mm

LEGEND					
in.	=	inches	Pa.	=	Pascals
ft.	=	feet	U.S. gal.	=	U.S. gallon
mm	=	millimeters	GPM	=	gallons per minute
cm	=	centimeters	L/s	=	liters per second
dm	=	decimeters	Kpa	=	1000 Pascals
CFM	=	cubic feet per minute	psi	=	pounds per square inch
m ³ /s	=	cubic meters per second	kg/m ²	=	kilograms per square meter
L	=	Liters	°F.	=	degrees Fahrenheit
			FPM	=	feet per minute
			m/s	=	meters per second
			in. W.G.	=	inches water gauge
			N	=	Newtons
			N/m ²	=	Newtons per square meter
			°C.	=	degrees Celsius
			BAR	=	one atmospheric pressure meter (1000 millibars = 14.7 psi)



VENTILATOR START-UP INSPECTION REPORT

For Model "CG3" Series Ventilators with C-6000 Series Control

Job Name _____

Gaylord Representative _____

Address _____

Representative Company Name _____

City/State _____ Zip _____

File Number _____ Date _____

Facility Contact Name _____ Phone # _____

CSA Contacted _____

MAKE-UP AIR

- Kitchen make-up air supply is turned on ____ Yes ____ No
- Type of make-up air
 - Ceiling Registers Built into Hood
 - Ceiling Linear Diffusers Other
- If ceiling register or linear diffusers approximate distance from face of hood _____

AIR VOLUME READINGS

Push "Start Fan" and take velocities. Record as follows: **Exhaust** record in the "EX" row, **Exhaust at Custom Air baffles** (if applicable) record in the "CA" row, and **Make-up Air** record in the "MA" row.

ITEM NO.	HOOD SERIAL NO.		AIR VELOCITIES (FPM) FROM LEFT TO RIGHT HOOD SLOT, FILTER BANK OR MAKE-UP AIR DISCHARGE				AVERAGE
		EX					
		CA					
		MA					
		EX					
		CA					
		MA					
		EX					
		CA					
		MA					

WASH MODE TEST:

- Model of Control Cabinet _____
- Push "START WASH" on Control Cabinet. Check the following:
 - A. Exhaust fan off ____ Yes ____ No
 - B. Damper closes to the front of the hood after approx. 70 sec. ____ Yes ____ No
 - C. Water turned on ____ Yes ____ No
 - D. All nozzles spraying ____ Yes ____ No
 - E. Green light is on and "Wash On" is displayed on C-6000 command center ____ Yes ____ No
 - F. Detergent pump operating ____ Yes ____ No
 - G. Length of wash cycle _____ Minutes
 - H. Water pressure _____ PSI
 - I. Water temperature _____ °F
 - J. Any ventilator leaks ____ Yes ____ No
 - K. Drains free and clear ____ Yes ____ No
 - L. Brand of detergent used _____
- At the conclusion of check A through L above, push the "EXIT" button on the C-6000 command center. Check the following: A. Did the water shut off ____ Yes ____ No B. Did the damper stay closed ____ Yes ____ No
- Push "START FAN". Check the following:
 - A. Green light comes on and "Fan On" is displayed on C-6000 command center ____ Yes ____ No
 - B. Damper fully opens after approx. 45 seconds ____ Yes ____ No

FIRE MODE TEST:

CAUTION: Before any fire tests are performed, check with building superintendent to see if Gaylord control cabinet is tied into building alarm, monitoring system and/or Fire Department.

THERMOSTAT TEST (For CG3, CG3-FDL, and CG3-FDT)

With the exhaust fan on, open electrical compartment on Control Cabinet and push and hold for 20 seconds the "Fire Test Switch". The following should occur:

- Damper closed to rear ____ Yes ____ No
(N/A on CG3-FDL and CG3-FDT)
- Water turned on ____ Yes ____ No
- Exhaust fan shut off ____ Yes ____ No
- Steady red light on and "Fire In Hood" displayed on C-6000 Command Center ____ Yes ____ No

NOTE: Water will continue to run for 5 minutes after the "Fire Test Switch" button is released. The water may be shut off prior to the end of the cool down cycle by pushing the "EXIT" button on the C-6000 command center.

Upon completion of the thermostat test push the "EXIT" button on the C-6000 command center. The following should occur:

- A. Water shut off ____ Yes ____ No
- B. Damper closes to front ____ Yes ____ No
(N/A on CG3-FDL and CG3-FDT)
- C. Steady red light turned off and "Fan Off" displayed on C-6000 Command Center ____ Yes ____ No

REMOTE FIRE SWITCH TEST (Optional Equipment): Equipped Not Equipped

Open fire switch and flip toggle switch to the "ALARM" or "TEST" position. The following should occur:

- Water spray turned on ____ Yes ____ No
- Damper remained open (or opens) ____ Yes ____ No
- Exhaust fan remained on (or turned on) ____ Yes ____ No
- Flashing red light on and "Ext. Fire Active" displayed on C-6000 Command Center

INSTALLATION INCLUDES THE FOLLOWING:

- Gaylord Heat Reclaim Unit (HRU)
- Gaylord Clearair Pollution Control Unit (RSPC)
- Gaylord Distributor (UDS)
- Gaylord Recirculating Wash System (GRW)
- The Gaylord "Quencher" Fire Protection System
- Gaylord Rooftop Unit (GRT)
- Wet Chemical Fire Protection System

Personnel provided with ventilator technical manual ____ Yes ____ No

Inspection Witnessed By (Print Name) _____

Signature _____ Date _____

Comments _____

Distribution: WHITE-Gaylord Industries, Inc. YELLOW-Customer PINK-Dealer GOLDENROD-Sales Rep Litho U.S.A. GAYLORD INDUSTRIES, 10900 S.W. Avery Street • Tualatin, OR 97062-1149

PHONE: 1-800-547-9696 • FAX: 1-503-692-6048 • email: info@gaylordusa.com

THE GAYLORD WATER-WASH VENTILATOR LIMITED WARRANTY

August 2000

The Gaylord Ventilator and component parts furnished with The Gaylord Ventilator are warranted to be free from defects of material and workmanship under normal use when installed, operated and serviced in accordance with factory recommendation. Rubber and synthetic rubber parts such as "O" rings, diaphragms and poppet checks are perishable when caustic cleaning solutions are used and, therefore, are not covered by this warranty.

The Manufacturer's obligation under this warranty and any warranties implied by law shall be limited to repairing or replacing at its option any part of said equipment when either Gaylord Industries, Inc. or the Licensed Gaylord Manufacturer's examination shall disclose to its satisfaction to be thus defective, for a period of one (1) year from the date of beneficial use, or eighteen months from date of shipment, whichever occurs first, provided proper and acceptable evidence of such is recorded at the factory. GAYLORD INDUSTRIES, INC. AND THE LICENSED GAYLORD MANUFACTURER SHALL NOT BE RESPONSIBLE FOR INCIDENTAL OR CONSEQUENTIAL DAMAGES RESULTING FROM A BREACH OF THIS WARRANTY.

In the United States, the labor required to make repairs and replacements under this warranty shall be furnished by Gaylord Industries, Inc. or the Licensed Gaylord Manufacturer or its authorized representative. Such labor shall only be provided Mondays through Fridays during the hours between 8 a.m. and 4 p.m. Requests for repairs or replacement parts should be made to GAYLORD INDUSTRIES, P.O. Box 1149, Tualatin, Oregon 97062-1149.

Outside the United States, all replacement parts furnished under this warranty shall be F.O.B. Gaylord Industries, Inc., Tualatin, Oregon U.S.A. The owner shall pay the necessary freight delivery charges, and necessary labor for removal and installation of parts, and any tariffs, duties or taxes.

Component parts not manufactured by Gaylord Industries, Inc., such as electrical switches, solenoid coils, relays, etc., shall be warranted under the terms and conditions of the warranty published by the manufacturer of said component parts.

This warranty does not cover routine maintenance such as detergent replacement and inspection of the cleaning system as spelled out in The Gaylord Ventilator Technical Manual. This warranty also does not cover malfunctions or improper operation caused by inadequate hot water, low water pressure, fluctuating electrical power or power surges, waste stoppages, and improper exhaust fan operation.

This is the sole warranty with respect to the aforesaid items. NEITHER GAYLORD INDUSTRIES, INC. OR THE GAYLORD LICENSED MANUFACTURER OR ANY OTHER PARTY MAKES ANY OTHER WARRANTY OF ANY KIND WHATSOEVER, EXPRESSED OR IMPLIED, AND ALL IMPLIED WARRANTIES OF MERCHANTABILITY AND FITNESS FOR A PARTICULAR PURPOSE WHICH EXCEED THE AFORESAID OBLIGATIONS ARE HEREBY DISCLAIMED AND EXCLUDED FROM THIS AGREEMENT.



**WORLDWIDE SALES, MANUFACTURING AND SERVICE
FOR THE NAME AND LOCATION OF THE NEAREST
CERTIFIED SERVICE AGENCY, VISIT OUR WEB SITE:**

WWW.GAYLORDUSA.COM

OR CONTACT US AT:

GAYLORD INDUSTRIES

10900 S.W. AVERY STREET
TUALATIN, OREGON 97062-1149 U.S.A

Phone: 503-691-2010

1-800-547-9696

Fax: 503-692-6048

email: info@gaylordusa.com

LOCAL SERVICE AGENCY