



Breathe easy.

**Technical Manual
For
Installation, Operation
And Maintenance
Of
The Gaylord "ClearAir"[™]
Model RSPC-ESP-OW Series
Pollution Control Unit**

GAYLORD INDUSTRIES

10900 SW Avery Street – Tualatin, Oregon 97062 USA

Email: info@gaylordventilation.com Toll Free 800-547-9696 – Fax 5023-692-6048

www.gaylordventilation.com

All rights reserved. No part of this book may be reproduced, stored in a retrieval system, or transmitted in any form by an electronic, mechanical, photocopying, recording means or otherwise without prior written permission of Gaylord Industries.

©Copyright 2016, Gaylord Industries

The manufacturer reserves the right to modify the materials and specifications resulting from a continuing program of product improvement or the availability of new materials



Breathe easy.

Gaylord Industries
10900 SW Avery St.
Tualatin, OR 97062
Office: 503.691.2010
Toll Free: 800.547.9696
www.gaylordventilation.com

To Our Customers:

Congratulations on your recent purchase of a Gaylord ClearAir™ Pollution Control Unit. We are proud to be able to provide you with a quality product that exemplifies our long standing dedication to quality engineering and manufacturing.

Your Command Center / Wash Control Cabinet is assembled from some to the very finest components available and is designed for years of efficient, effective, and trouble-free operation. In addition, the product has undergone rigorous quality control inspections and testing prior to shipment.

If you have any questions, please contact us at info@gaylordventilation.com or by calling us toll free 800-547-9696. We are more than happy to help.

Sincerely,

Gaylord Industries

This Page Intentionally Left Blank

Table of Contents

Chapter 1 – Introduction

About the Manual	1-1
Introduction.....	1-2
Basic Facts About Smoke	1-2
Basic Facts About Odor	1-3
Grease Removal - The Important First Step	1-3
Specifications	1-4

Chapter 2 – Models and Configuration

Model Number Chart	2-1
Typical Installation	2-3
Sample ClearAir Configurations	2-5

Chapter 3 – Daily Operation

Overview	3-1
Starting the exhaust fan and ClearAir Unit	3-1
Stopping the exhaust fan and starting the ClearAir Wash Cycle	3-3
Fire Cycle	3-4
Chemical Fire Extinguishing Systems	3-4
Maintenance - Detergent	3-5
Maintenance – Spray Odor Control	3-5
Periodic Pressure Wash or Steam Cleaning	3-5

Chapter 4 – Smoke Control Section

Principle of Operation.....	4-1
Smoke Control – Wash Cycle	4-2
Smoke Control – Wash Cycle Water Consumption	4-7
Smoke Control – Wash Cycle – Recommend Detergent	4-8
Smoke Control - Maintenance	4-10
Smoke Control – Troubleshooting	4-20
Smoke Control - Troubleshooting (Charts)	4-20
Smoke Control – Trouble Shooting	
Green ESP Light Off Condition	4-22
Testing Voltages at the Cell Connection Points	4-23
Testing Door Safety Switch	4-23
Testing Plunger Safety Switch	4-24
Transformer Voltage Test	4-25
Testing ESP Cells	4-27
Shorting Cell Plates	4-29
Replacing Ionizing Wires	4-30
Wash System – Troubleshooting	4-31
Wash System Troubleshooting Charts	4-31
Inadequate Washing of the ESP Cells	4-34
Frequency of Wash Cycle	4-34
Length of Wash Cycle	4-34
Length of Delay Between Wash Cycles	4-34

Table of Contents – Cont.

Clogged Spray Nozzle	4-35
Oscillating Wash	4-38
Wash Control Cabinet	4-41
Detergent Pump	4-41
Detergent Flow Ratio	4-46
Detergent Consumption	4-47
Detergent Flow Switch	4-47
Line Strainer	4-48
Backflow Preventer	4-48
Water Solenoid Valve	4-50
Chapter 5 – Odor Control Section	
Overview	5-1
Media Panel Type Odor Control.....	5-1
Loose Fill Type Odor Control	5-1
Odor Control Maintenance – Media Panel Type	5-2
Odor Control Maintenance – Loose Fill Media	5-4
Spray Odor Control - Overview	5-6
Spray Odor Control – Setting Timers	5-7
Spray Odor Control – Maintenance	5-7
Spray Odor Control Chemical	5-8
Chapter 6 - Exhaust Fan Section	
Overview	6-1
Initial Set-Up	6-1
Pre-Operational Maintenance	6-2
Initial Fan Lubrication	6-2
Idle Fan Requirements	6-3
Initial Operation	6-3
Preventive Maintenance	6-3
Troubleshooting	6-4
Chapter 7 – Parts	
Overview	7-1
Parts List – Miscellaneous	7-1
Parts List – ESP Cells	7-4
Parts List – Electrical Compartment	7-5
Parts List – Main Electrical Compartment	7-6
Parts List – Wash Control Cabinet	7-7
Parts List – Detergent Pump	7-8
Parts List – Spray Odor Control	7-9

Table of Contents – Cont.

Chapter 8 – Wiring Diagrams

Eight Diagrams Beginning on Page 8-1

Appendix “A” – Receiving, Rigging and Storage

Overview A-1

Receiving A-1

Safety Considerations A-1

Odor Control Media Short Term Storage A-1

Exhaust Fan Receiving and Storage A-1

Rigging A-2

Appendix “B” – Assembly

Overview B-1

Assembly Instructions B-1

Appendix “C” - Installation

Installation Codes C-1

Installation Precautions C-1

Appendix “D” – Nameplate

Sample Nameplate D-1

Appendix “E” – Cell Rotation and Filter Cleaning Log Sheet

Sample Log Sheet E-1

Appendix “F” – Startup, Inspection and Tests

Overview F-1

Pre Startup Requirements F-1

Pre Startup Check List F-1

Startup Inspection and Test Report Forms F-2

Limited Warranty Inside Back Cover

This Page Intentionally Left Blank

About this Manual

The purpose of this manual is to provide the Operator, Maintenance and Service personnel instructions for operating, maintaining and troubleshooting the Gaylord ClearAir™ Pollution Control Unit, Model RSPC-ESP-OW. This manual also includes information and guidance to contractors for the initial installation of the Unit.

The manual is divided into chapters for easy reference to a particular subject. The pages in the chapters are numbered with the Chapter number, then a dash, and then the Page number. So for example pages in Chapter 2 are numbered 2-1, 2-2, 2-3 etc. Figures and Tables are numbered in a similar manner. For example Figure 5-3-2 is on Page 5-3 and is the second figure. Please keep your manual in a convenient location for so it can be accessed easily.

If you have any questions regarding the Gaylord ClearAir Unit please contact Gaylord Industries.

Web: www.gaylordventilation.com

E-Mail: info@gaylordventilation.com

Main Phone: 503-691-2010

Toll Free: 800-547-9696

This manual and other Gaylord product manuals may be downloaded from the Gaylord website: www.gaylordventilation.com or be purchased by calling Gaylord Industries.

Introduction

Air Quality is becoming a major concern in America's large cities and as a result, many commercial kitchens will require pollution control equipment in their exhaust systems to comply with the increasing demands of environmental control agencies. In addition, pollution control equipment is being used for kitchens in high-rise buildings allowing the exhaust to discharge out the side of the structure which saves the cost of running the duct up many floors to the roof.

Pollution control in kitchen exhaust systems has typically been accomplished by any one of the following methods - gas fired incinerators, scrubbers, filtration units or electrostatic precipitators. Incinerators and afterburners literally burn the pollutants and, while effective, can be very costly and hazardous to operate. Scrubbers consist of a water bath and extraction baffles to remove the pollutants and though quite effective on grease removal, they typically require the addition of high efficiency filters to abate smoke below control agencies' standards. Filtration units use a series of impingement filters to remove the pollutants and if done properly can be quite effective on both smoke and grease.

The Gaylord pollution control unit, trademarked ClearAir, can be manufactured with either electrostatic precipitation (ESP) or Filtration (TPF). Gaylord Industries has been manufacturing ESP's specifically designed for commercial kitchen exhaust systems since the early 1970's, longer than any other manufacturer. However, when initial cost is a greater concern the TPF unit is a sound alternative.

The ClearAir ESP unit is available in several configurations, as illustrated on the following pages, ranging in capacity from 1000 to 32,000 CFM (472 to 15,102 L/s). Most models can include exhaust fan and odor abatement equipment as an option.

Basic Facts About Smoke

Smoke particles are extremely small and not visible to the human eye unless thousands of them are grouped together to form what we see as smoke. Individual particles are measured in units called microns and one micron equals 1/25,400 of an inch (1/64,516 of a cm).

Smoke generated by commercial cooking equipment has a particulate size of 0.15 microns and it is these very small particles that smoke abatement equipment must remove from the airstream. The amount of smoke being discharged from a kitchen exhaust duct is measured in terms of its density, referred to as opacity - the degree to which emissions block light. A 100% opacity level would be solid black and 0% would be perfectly clear. Control agencies that have adopted smoke pollution ordinances are requiring an opacity level of no more than 20%, which is a very light blue smoke.

Typically, heavy smoke producing cooking such as charbroiling creates an opacity level of 60% to 70%. Opacity readings are taken by the human eye by viewing the smoke being discharged and then assigning a percentage of opacity to what is seen. Though this method is quite subjective, it is the method practiced by control agency inspectors who are trained and certified in determining opacity percentages.

Introduction (Cont.)

Other more technical methods of determining opacity or particulate density are achieved through the use of opacity meters and cascade impactors. This level of analysis is usually referred to as source testing. Control agencies occasionally require this type of analysis and if so, the testing is conducted by state certified contractors which can be quite costly and time-consuming. The efficiency of a pollution control unit is based on how well it reduces the opacity level of a given airstream. The Gaylord ClearAir unit will reduce the opacity level below 20%, thereby meeting the requirements of environmental control agencies.

Basic Facts About Odor

Cooking odors (molecules) generated by the combustion of animal and vegetable matter result in an extremely complex mixture of reactive organic gases (ROG's). A small percentage of these odors may be absorbed by the grease particles but the vast majority exists separately in the airstream. The ROG molecules are much too small to be removed by any type of filter and therefore, other methods must be used. There are several methods with which to manage the odor. One method is to use a media bed. The three most popular types of media bed are activated charcoal, which absorbs and retains the odor molecules, the use of an odor-oxidant media (potassium permanganate) which oxidizes the molecules to solids and then retains them, and a blend of the two. Another method involves the use of a liquid delivered with a finely atomized spray. This spray performs a similar function to potassium permanganate in that it adsorbs or chemically neutralizes odors. This process has the benefit of the end user being able to adjust the amount of spray and thus the effectiveness and cost of the odor control.

The life of the media bed type of odor control is dependent upon several factors such as how much media is used, type of odor, amount of odor molecules, grease loading and air temperature. Typically, any of the above mentioned types of media can remove 85% - 90% of the molecules. Determining the efficiency of odor control can be very subjective, as testing is usually conducted by the human nose. More scientific testing is available through ROG analysis, but this involves considerable costs.

Grease Removal - The Important First Step

Grease particles are also measured in terms of microns and grease generated by commercial cooking equipment has a particulate size of 0.1 microns and up. Pollution control equipment is not limited to removing smoke particles, but will also remove a majority of the grease particles remaining in the airstream. Therefore, the grease extraction efficiency of the exhaust hood plays an important role in the operation and performance of pollution control equipment.

Removal of grease particles before they reach smoke and odor control equipment will significantly increase the smoke abatement efficiency and the life of the odor abatement media.

Specifications

General

Furnish one (1) Gaylord ClearAir Pollution Control Unit model RSPC-ESP series as manufactured by Gaylord Industries of Tualatin, Oregon in accordance with the following:

The pollution control unit shall consist of a smoke control section, odor control section (optional) and an exhaust fan section (optional) all built on a common base as an integral unit.

Smoke Control Section

The smoke control section shall contain one or more electrostatic precipitator (ESP) Cells to remove smoke particles from the air stream to a level no higher than 20% opacity when operated in accordance with the operation and maintenance guidelines. The ESP Cells shall be of a floating plate design to eliminate plate warpage during high heat operation. The Cells shall be positioned on slide tracks so that they may be easily removed through a hinged Cell access door(s). For ease of handling, individual Cells shall weigh less than 54 lbs. There shall be removable, cleanable debris screens located immediately upstream of the ESP Cells and a moisture separator immediately downstream. An electrical panel mounted on the unit shall contain the high voltage power pack assembly, safety disconnect switch, main disconnect switch, fuses and a magnetic starter for the exhaust fan when fan is included. The safety disconnect switch shall interface with the electrical panel access door such that when opened it will shut off service to the power pack(s) and ground them to drain the residual electrical charge from both the power pack(s) and ESP Cells. The ESP Cell access door shall interface with the electrical panel access door so that it cannot be opened without first opening the electrical panel access door. The high voltage power pack(s) shall be self-limiting type and shall be self-contained. The electrical panel shall include indicating lights to monitor Cell and transformer voltage. The main disconnect switch for the exhaust fan and control circuits shall lock the electrical panel access door closed when in the “on” position. The unit shall contain one or more wash manifold(s) with brass spray nozzles to wash the ESP Cells with hot detergent injected water each time the exhaust fan is shut off.

Fire Detection

A thermostat, set at 250⁰ F, shall also be located in the filter section to shut down the exhaust fan in the event of a fire.

Optional Fire Damper for use in Canada

___The unit shall include a UL listed fire damper, with a 280⁰ F fusible link, located downstream of the filters to prevent passage of fire to the duct downstream of the unit

Odor Control Options

___Media bed of 50/50 Blend Potassium Permanganate and Carbon Blend

The unit shall be provided with odor control utilizing a media bed of 50% potassium permanganate 50% carbon blend. There are two design methods of housing the media used in the ClearAir unit. One is called the Loose Fill type and the other is called the Media Panel type.

___Loose Fill type – The odor control media shall be housed in steel reusable Media Modules that can be replenished with Loose Fill media. There shall be a 30% pleated media After Filter located immediately downstream of the Media Models.

Specifications (Cont.)

The Modules and After Filters shall be mounted into slide tracks to prevent air bypass around the ends. The Modules and After Filters shall be removable through side access doors with lift and turn latches.

___ Media Panel type – The odor control media shall be compressed into Media Panels that slide into Media Modules. The Modules shall be mounted into slide tracks to prevent air bypass around the ends. The Modules and shall be removable through side access doors with lift and turn latches.

___ (*optional*) The unit shall be equipped with a 30% pleated media After Filter located immediately downstream of the Media Models.

___ The unit shall be equipped with a Single Pass Media Bed.

___ The unit shall be equipped with a Double Pass Media Bed.

___ The unit shall be equipped with a Triple Pass Media Bed.

Spray Odor Control

The unit shall be provided with a spray odor control system utilizing an odor neutralizer chemical. The odor spray control cabinet shall be mounted on the side of the unit and shall contain a liquid spray compressor piped to the spray nozzle in the fan plenum, adjustable delay timers with fuse protected circuitry factory wired to the unit electrical panel. The cabinet shall include one 5 gallon container of Gaylord Formula GS-710 Odor Neutralizer. The cabinet shall contain a heater to prevent freezing of the odor neutralizer, if mounted outdoors.

Exhaust Fan Options

___ Exhaust Fan (Standard Centrifugal Fan)

The unit shall include a centrifugal exhaust fan. The exhaust fan shall be an SWSI up-blast arrangement #9 or #10 with a non-overloading BI or AF wheel. The motor, drives, bearings and fan mounting base shall be located out of the exhaust air stream as required by the IMC (International Mechanical Code) and NFPA-96. The fan shall be AMCA certified and bear the AMCA seal for performance. The fan housing shall be constructed of heavy gauge steel. The fan bearings shall be heavy duty self-aligning pillow block type rigidly mounted on heavy structural steel supports. The motor shall be P.E. rated, ODP three phase mounted on a common base with the fan and shall be pre-wired to the electrical cabinet located on the unit. The electrical cabinet shall include a disconnect switch, motor starter, overloads and fuses. The factory provided drive assembly shall be adjustable pitch on 5 HP and smaller, fixed pitch on 7.5 HP and larger. It shall also be sized for a minimum 1.5 service factor. After final system balancing, fixed pitch sheaves shall be provided and installed by the air balancing contractor to provide proper flow at actual installed conditions.

___ Exhaust Fan (Optional Tubular Fan)

The unit shall include a tubular centrifugal exhaust fan. The exhaust fan shall be an arrangement #10 with a non-overloading BI, AF wheel. The motor, drives, bearings and fan mounting base shall be located out of the exhaust air stream as required by the IMC (International Mechanical Code) and NFPA-96. The fan shall be AMCA certified and bear the AMCA seal for performance. The fan housing shall be constructed of heavy gauge steel. The fan bearings shall be heavy duty rigidly mounted on heavy structural steel supports. The motor shall be P.E. rated, ODP three phase mounted on a common base with the fan and shall be pre-wired to the electrical cabinet located on the unit. The electrical cabinet shall include a disconnect switch, motor starter, overloads and fuses. The factory provided drive assembly shall be adjustable pitch on 5 HP and smaller and fixed pitch on 7.5 HP and larger. It shall also be sized for a minimum 1.5 service factor. After final system balancing, fixed pitch sheaves shall be provided and installed by the air balancing contractor to provide proper flow at actual installed conditions.

Specifications (Cont.)

Exhaust Fan Housing

The exhaust fan section of the unit shall be enclosed with the same material as the smoke control section. There shall be a removable panel for access to the fan.

Unit Construction

The unit housing shall be constructed of a minimum of 16 gauge G90 bright galvanized steel. The perimeter base shall be 12 gauge formed channel with lifting lugs at each corner and along the length as required. The internal housing shall be externally welded liquid tight for compliance to the International Mechanical Code and NFPA-96 grease duct construction requirements.

Fire Extinguishing System Options

Specifier Note: NFPA-96 requires a fire extinguishing system for protection of the smoke and odor control sections and protection of the duct downstream of any filters or dampers. Not all authorities having jurisdiction require protection. Check with your AHJ. If required, specify one of the following systems.

___Wet chemical system

Provide a complete factory mounted Ansul wet chemical fire extinguishing system, including nozzles piping and detection runs. Pipe penetrating the unit cabinet shall use a UL listed fitting. System shall be installed in accordance with the systems listing and NFPA-96. The Ansul Automan cabinet shall be mounted on the side of the unit for easy access, certification and service.

___Water spray sprinkler fire system

Specifier Note: Units that are located indoors, or in locations that do not freeze, may be factory pre-piped for a wet pipe building sprinkler system.

Provide a pre-piped water spray fire system installed in accordance with NFPA-96. The unit shall be piped with one pendent type sprinkler nozzle located in the smoke control section, one in the odor control section, if equipped with 50/50 media bed, and one in the exhaust fan section for interconnection to the building sprinkler system by the appropriate trades. Pipe penetrating the unit cabinet shall use a UL listed fitting. Nozzles shall be the bulb type rated at 325⁰ F.

Check Out and Demonstration

Upon completion of installation, the entire pollution control system, including the kitchen exhaust hoods, shall be commissioned by factory certified personnel. Start-up shall include checking all functions of the ClearAir unit. The appropriate maintenance personnel shall be given a technical manual and a complete demonstration of the system, including operation and maintenance procedures. Upon completion of the commissioning, a detailed start-up report shall be made available to the architect and owner certifying proper system operation. Changes required in fan drive components shall be performed by the air balancing contractor under the direction of the factory certified person(s) performing the start-up.

Model Numbers

The assigned model number of a ClearAir RSPC-ESP unit will indicate the number of Cell banks and if equipped with spray odor control, single or double pass odor control, if it has an exhaust fan plus other data. The following example shows the make-up of a model number.

The model number of your ClearAir unit along with other data can be found on the nameplate which is attached to the electrical control panel on the ClearAir unit. Refer to Figure D-1-1 in Appendix D.

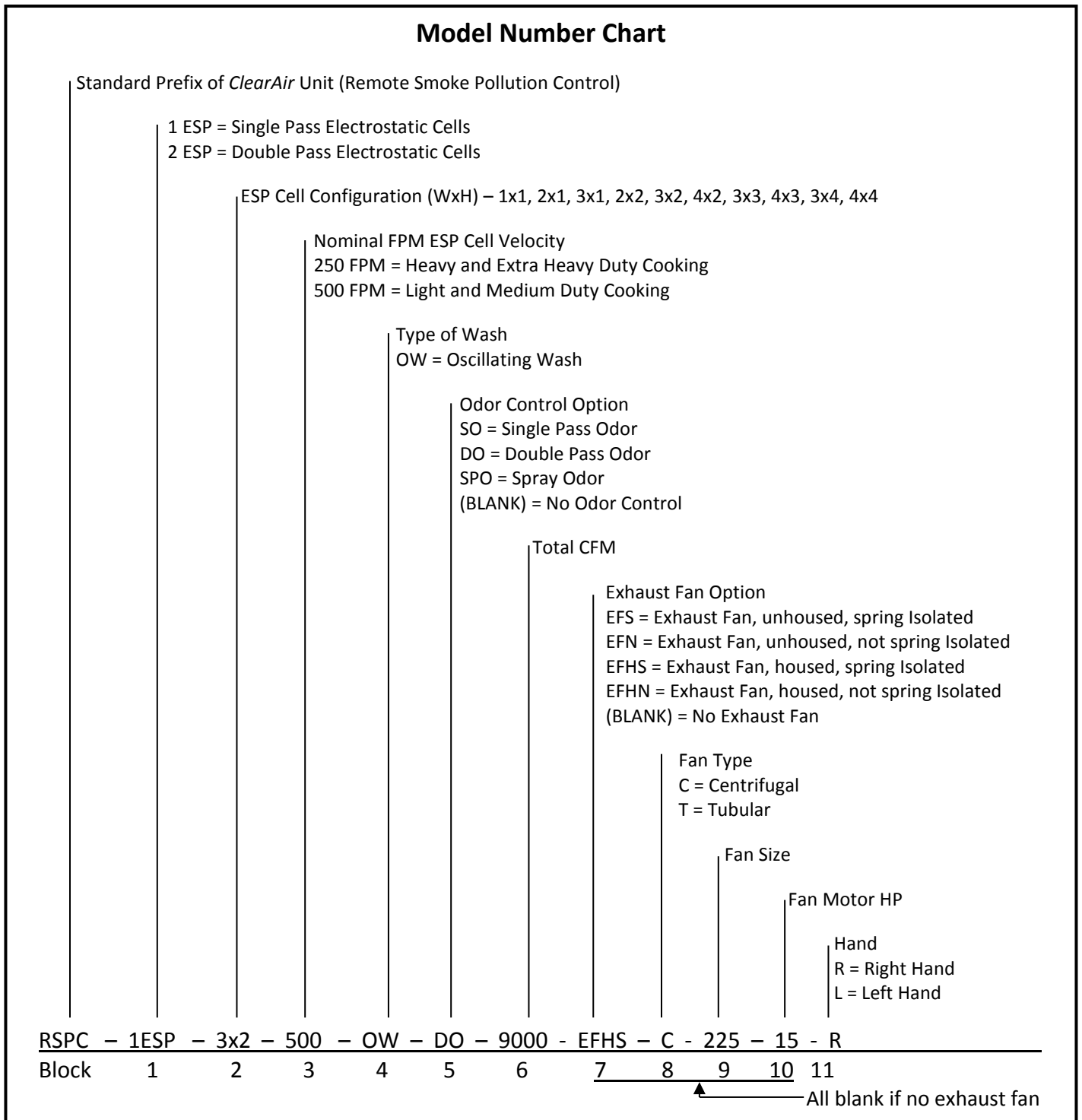

Model Numbers (Cont.)

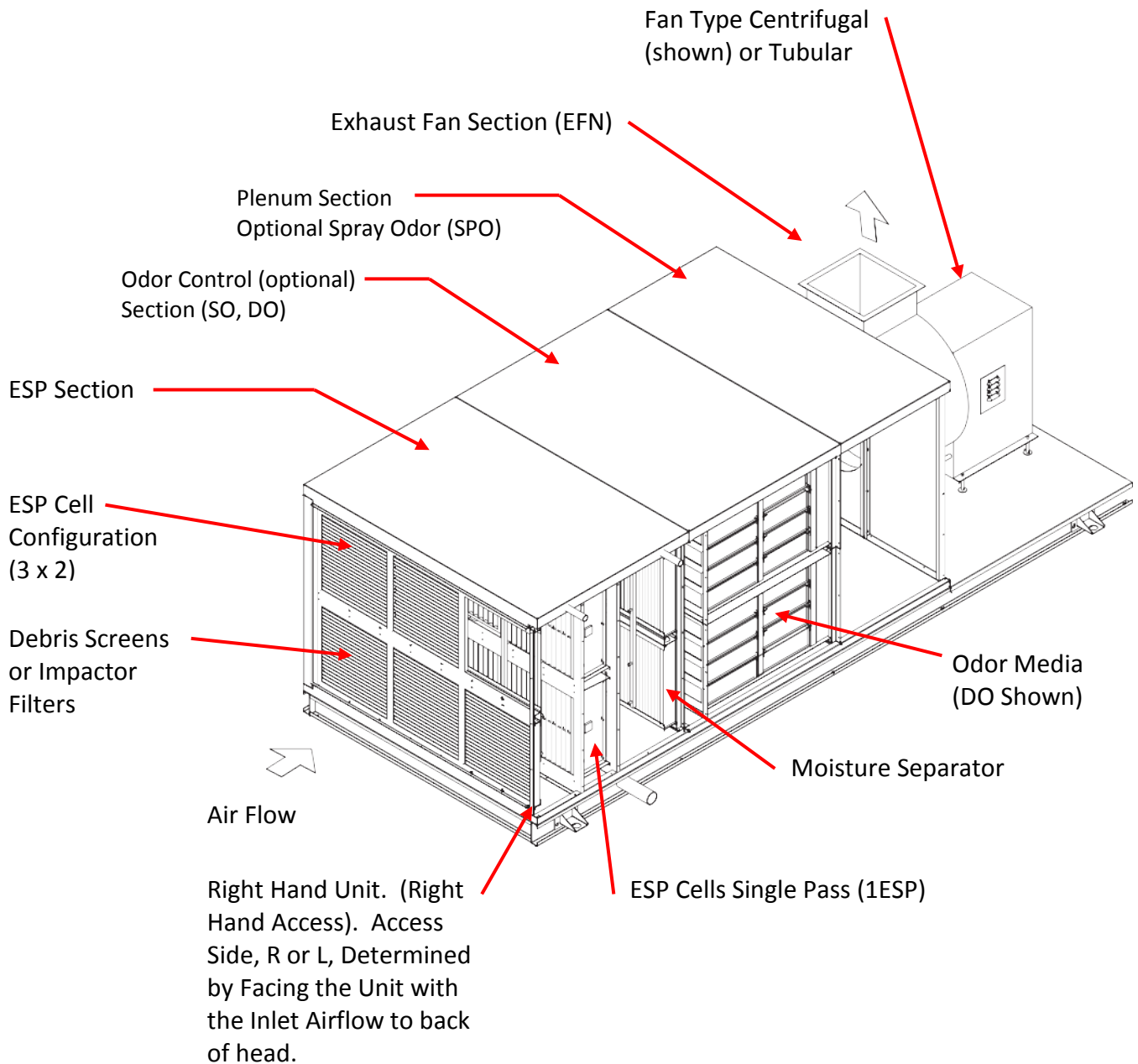

Figure 2-2-1
Typical ClearAir Unit
Without Fan Enclosure

Typical Installation

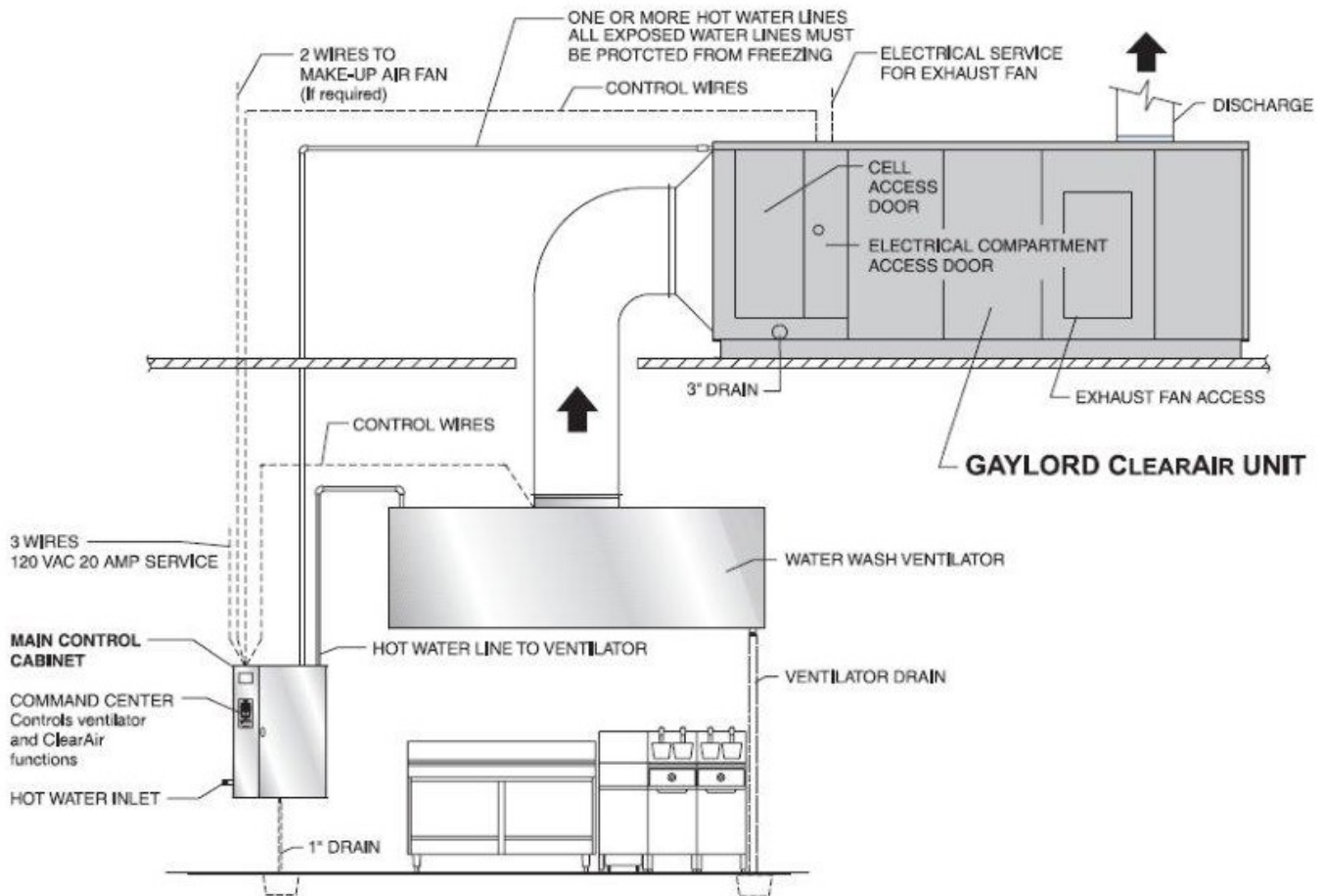

Figure 2-3-1

Typical Arrangement with Water Wash Ventilator with the Main Control Cabinet Serving Both the Water Wash Ventilator and the ClearAir Unit

Typical Installation (Cont.)

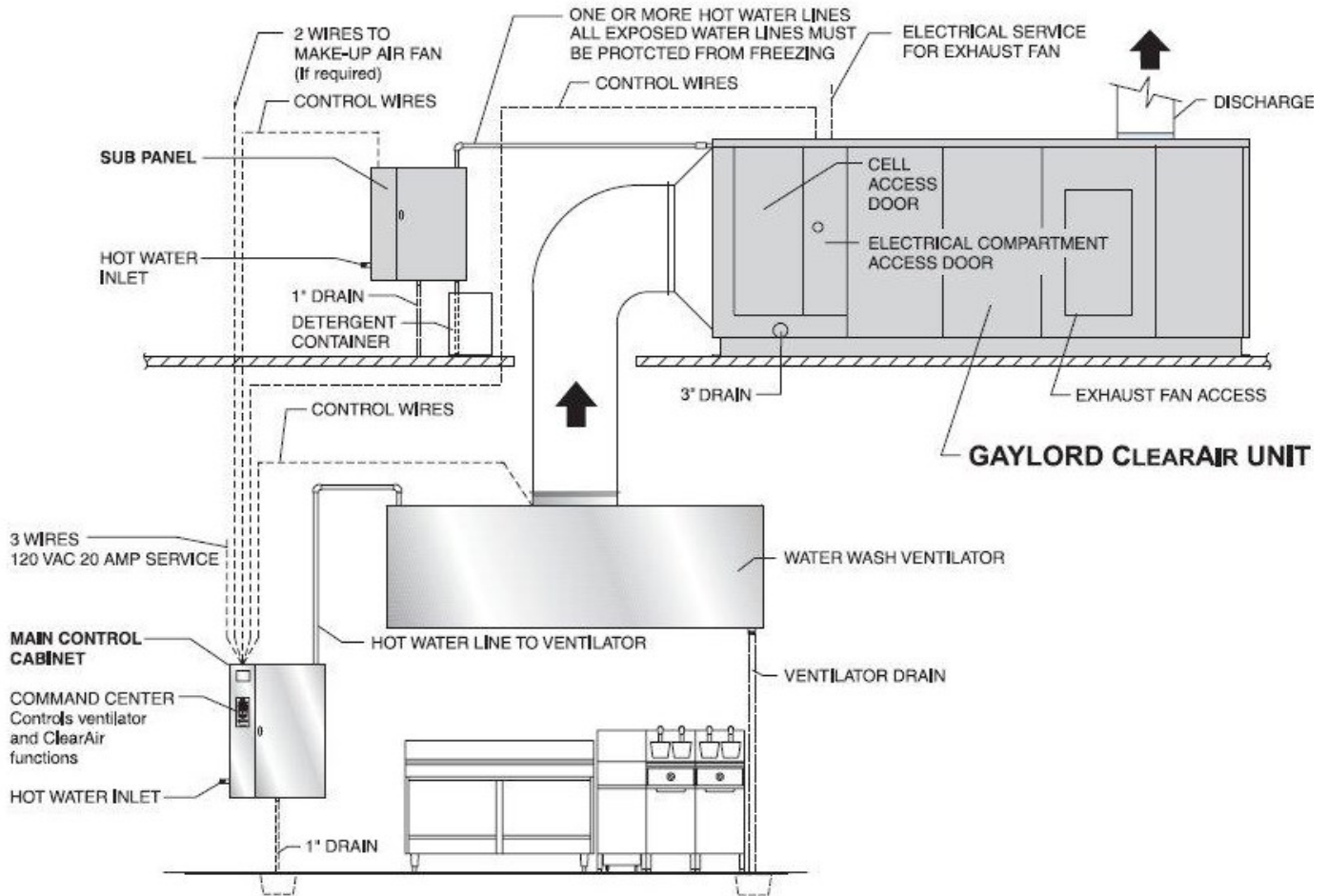

Figure 2-4-1
Typical Arrangement with Water Wash Ventilator with the Main Wash Control Cabinet Serving the Water Wash Ventilator and Sub Panel Serving the ClearAir Unit

Sample ClearAir Configurations

The ClearAir unit is available in sizes ranging in capacity from 100 to 32,000 CFM (472 to 15,102 L/s). Each unit is equipped with Electrostatic Precipitators for smoke control, and may include an exhaust fan, odor abatement equipment and an Ansul fire extinguishing system as an option. The following illustrations are examples of the most common configurations.

1ESP = Single Pass Electrostatic Cells
 2ESP = Double Pass Electrostatic Cells
 AF = 30% After Filter - Optional
 DO = Double Pass Odor Control
 DS = Debris Screen
 EFS = Exhaust Fan, unhooded, spring isolated
 EFN = Exhaust Fan, unhooded, not spring

EFHS = Exhaust Fan, housed, spring isolated
 EFHN = Exhaust Fan, housed, not spring isolated
 FD = Optional Curtain Fire Damper
 MS = Moisture Separator
 SO = Single Pass Odor Control
 SPO = Double Spray Odor Control Cabinet

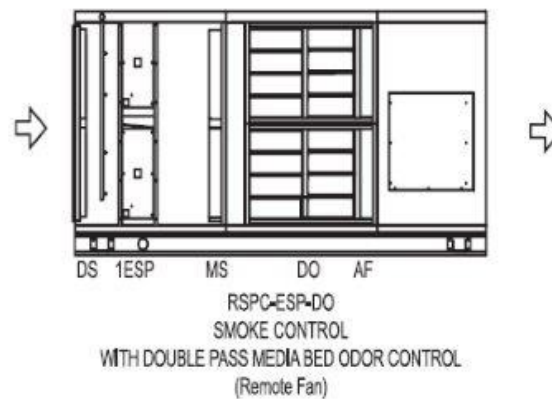
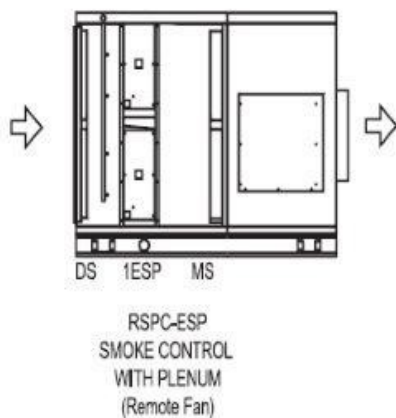
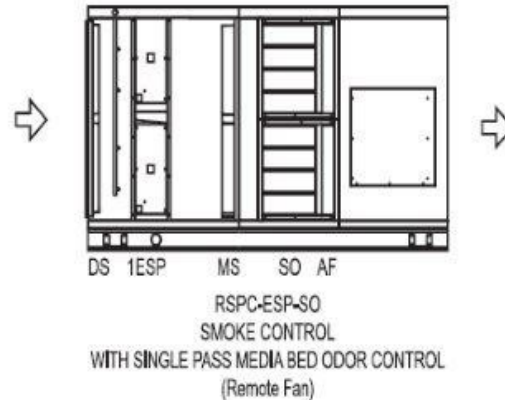
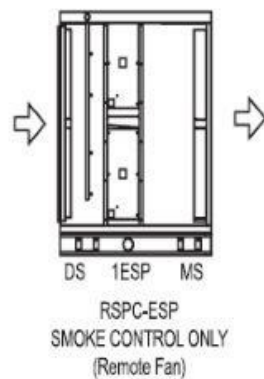

Sample ClearAir Configurations (Cont.)

1ESP = Single Pass Electrostatic Cells
 2ESP = Double Pass Electrostatic Cells
 AF = 30% After Filter - Optional
 DO = Double Pass Odor Control
 DS = Debris Screen
 EFS = Exhaust Fan, unhooded, spring isolated
 EFN = Exhaust Fan, unhooded, not spring isolated

EFHS = Exhaust Fan, housed, spring isolated
 EFHN = Exhaust Fan, housed, not spring isolated
 FD = Optional Curtain Fire Damper
 MS = Moisture Separator
 SO = Single Pass Odor Control
 SPO = Double Spray Odor Control Cabinet

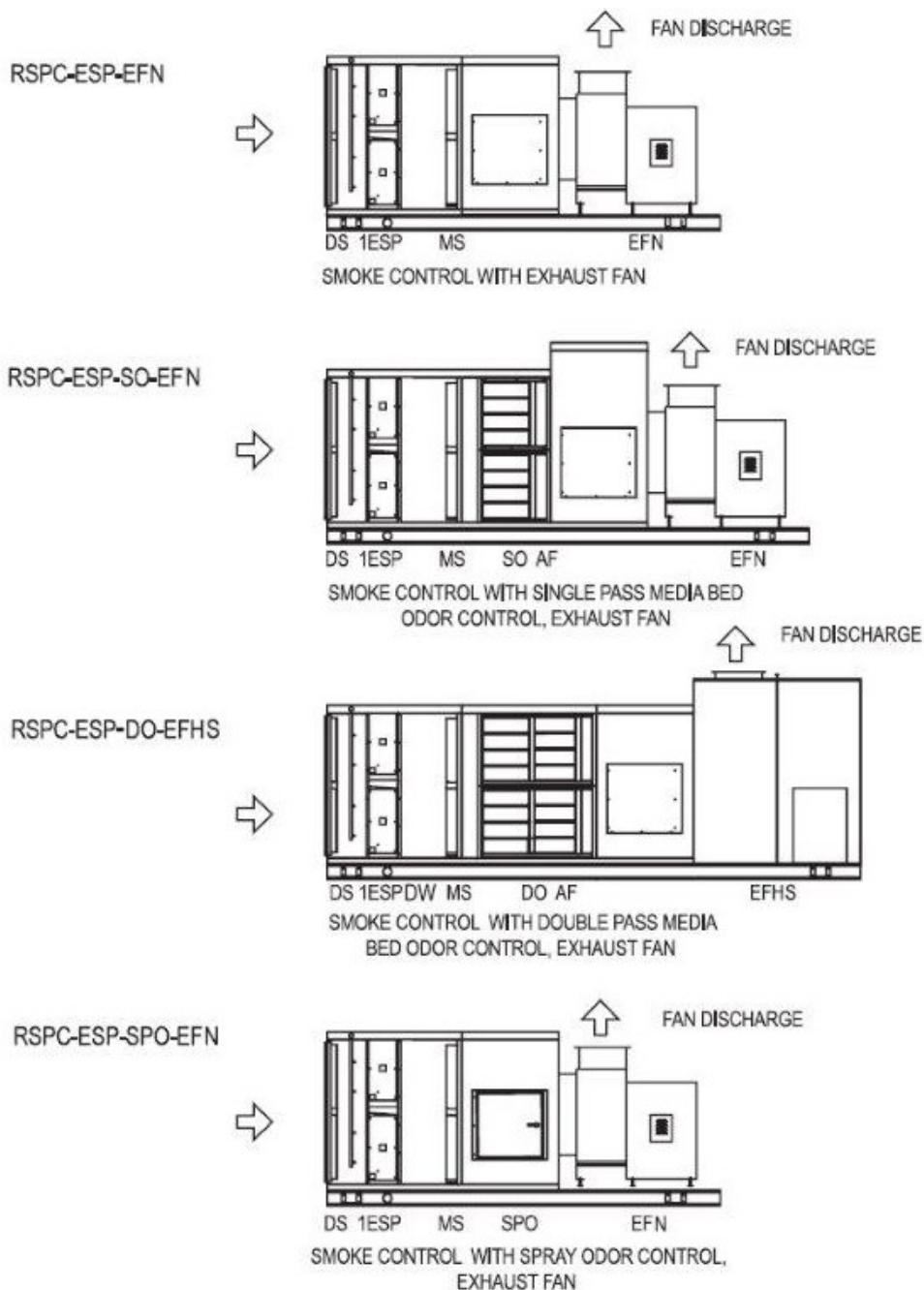

Daily Operation

Overview

All functions of the Gaylord Ventilator and ClearAir Unit, such as starting the Exhaust Fan, starting the wash cycle, etc., are controlled by the Command Center located on the Main Control Cabinet (Refer to Figure 3-1-1). The ClearAir Unit contains an internal wash system that is activated each time the Exhaust Fan is turned off. Upon activation the ESP Cells are washed in sequence with hot detergent injected water for a programmed period of time to wash away the accumulation of smoke and grease particles. At the conclusion of the detergent wash cycle the ESP Cells are rinsed with hot water.

Starting the Exhaust Fan and ClearAir Unit

Caution: Always turn on the exhaust fan before turning on the cooking equipment.

Caution: The chemical fire extinguishing system may discharge if the exhaust fan is not on while the cooking equipment is on or still hot.

To start the Exhaust Fan and ClearAir Unit push the START FAN button on the Gaylord Command Center (Refer to Figure 3-1-1). If the Command Center is programmed to start the fan automatically then the START Fan button does not need to be pushed. Note; many Ventilators are equipped with Gaylord Autostart which automatically starts the Exhaust Fan if the thermal detectors located in the canopy of the Ventilator reach their set point. Anytime the Exhaust Fan is on the ClearAir Unit is also on.

Upon pushing the START FAN button following will occur:

1. The Exhaust Fan will come on.
2. The Makeup-Air system will come on.
3. The ESP cells will energize.
4. The system green Status Light will come on (Refer to Figure 3-2-1).
5. If equipped with spray odor control it will come on.

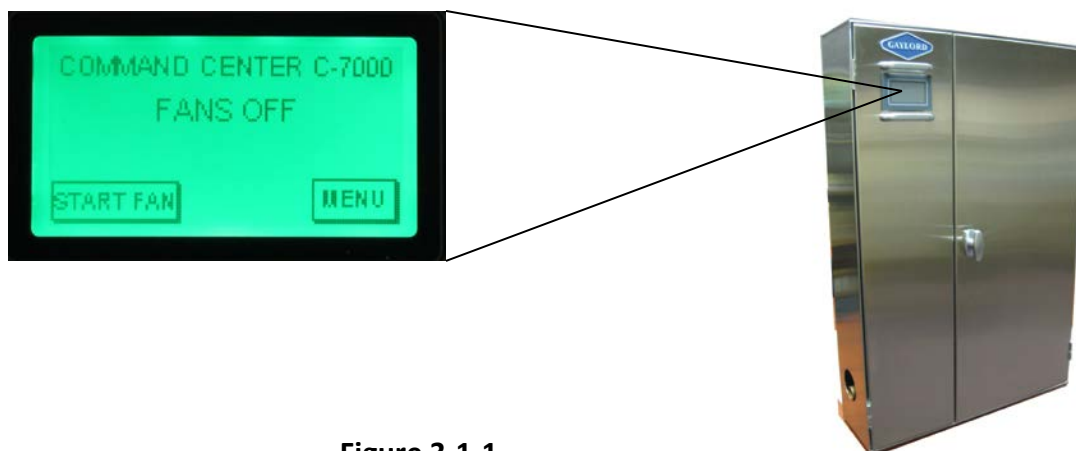

Figure 3-1-1
Typical Main Control Cabinet with
Command Center

Daily Operation (Cont.)

Status Lights

There are one or more Status Lights located on the face of the Main Command Center Cabinet to monitor the status of the ESP Cells (Refer to Figure 3-2-1) or it may be displayed on the Command Center Screen. There is a duplicate set of Status Lights mounted on the ClearAir unit. One Status Light monitors up to four ESP Cells. The Status Light advises the following:

Solid Green Light - This is a normal condition indicating that the ESP Cells are operating properly.

Fluctuating Green Light - Normally a fluctuating green light is a temporary condition, lasting until the Cells are dry, immediately following a wash cycle. This is caused by moisture left between the Cell plates which will evaporate.

Green Light Off - A green light off indicates one of the following conditions exists:

1. ESP Cell Door Open
2. Plunger Safety Switch is in the disconnect position.
3. Faulty Plunger Safety Switch.
4. Voltage not getting to Cells.
5. Faulty Cell.
6. Transformer failure.

Refer to the Troubleshooting section of this chapter beginning on page 4-18 for corrective action.



Figure 3-2-1
Typical Status Light

Daily Operation (Cont.)

Stopping the Exhaust Fan and starting the ClearAir Unit Wash Cycle

Caution: Always turn off the cooking equipment and allow cooling before turning off the exhaust fan. The chemical fire extinguishing system may discharge if the cooking equipment is on or hot when the exhaust fan is off.

To stop the Exhaust Fan and begin the ClearAir Unit Wash Cycle push the STOP FAN button on the Gaylord Command Center (Refer to Figure 3-3-1). If the Command Center is programmed to stop the fan automatically then the STOP FAN button does not need to be pushed. Note; many Ventilators are equipped with Gaylord Autostart which automatically starts the Exhaust Fan if the thermal detectors located in the canopy of the Ventilator reach the set point temperature. If the detectors are above the set point the exhaust fan will not stop until the temperature in the Ventilator drops below the set point for 60 minutes.

Figure 3-3-1
Typical Command Center



Upon pushing the STOP FAN button the following will occur:

1. The Exhaust Fan will shut off.
2. The Makeup-Air system will shut off.
3. The ESP sells will shut off.
4. The system Status Light will turn off.
5. If equipped with spray odor control it will shut off.
6. The ClearAir wash cycle will begin. **Important Note:** If the ClearAir Unit is connected to a water wash type Ventilator, the Ventilator's wash cycle always precedes the ClearAir wash cycle.

Upon activation the ClearAir Unit washes in the following sequence:

Wash Cycle Sequence Units with 1 to 16 Cells

1. 3 minute wash
 2. Between a 1-99 minute delay
 3. 3 minute wash
 4. Between a 1-99 minute delay
 5. 3 minute rinse
- The wash cycle is finished

Wash Cycle Sequence Units with 18 to 32 Cells

1. 3 minute wash
 2. Between a 1-99 minute delay
 3. 3 minute wash
 4. Between a 1-99 minute delay
 5. 3 minute wash
 6. Between a 1-99 minute delay
 7. 3 minute wash
 8. Between a 1-99 minute delay
 9. 3 minute rinse
 10. Between a 1-99 minute delay
 11. 3 minute rinse
- The wash cycle is finished

Daily Operation (Cont.)

The delay time between the washes and rinses are programmed in the Command Center for a length of time to allow the building's hot water system to recover. The delay time may be programmed between 1 and 99 minutes. The 3 minute wash cycles are the standard wash times. If the ESP Cells are not adequately cleaned it may be necessary to increase the length of the wash cycle and/or increase the length of the rinse time to allow more soaking time. The wash and rinse cycles may be programmed for between 3-9 minutes.

NOTE: The wash system is designed to remove daily accumulations of smoke and grease particles in the ESP Cells. If the ClearAir Unit is not washed a minimum of once during a cooking day, a smoke and grease buildup could accumulate which the wash system cannot remove. If this occurs, the ESP Cells will no longer remove the smoke particles. Refer to the Troubleshooting section of this manual for corrective action.

Important Note:

The wash, delay and rinse times may be programmed for different times as needed to adequately clean the ESP Cells. The Command Center illustrated in this manual may not represent the model of Command Center you have. Refer to the Technical Manual for your specific model of Command Center for complete instructions on programming wash, delay and rinse cycle times. If you do not have a Technical Manual for your Command Center, obtain the model number from the nameplate on the Command Center and contact Gaylord Industries. Refer to page 1-1 for contact information.

Fire Cycle

Automatic internal fire protection is accomplished by the action of the thermostat(s) located in front of the ESPC Cells. In the event of a fire within the unit, when the temperature of the conveying airstream, which must pass over the thermostats, reaches 250°F, the Fire Cycle is activated which turns off the exhaust fan. After the thermostat has cooled below 250°F, the exhaust fan may be restarted by pushing the START FAN button. As an option, the ClearAir Unit may be wired so in addition to the exhaust fan shutting off the water sprays within the ClearAir Unit come on. The water will run continually until the thermostat cools below 250°F then run for another 2 minutes. At the conclusion of this cool down cycle the water will shut off and the exhaust fan may be started by pushing the START FAN button.

Chemical Fire Extinguishing System

The National Fire Protection Association Standard 96, (NFPA-96) requires a fire extinguishing within the ClearAir unit. Typically this is wet chemical type furnished and installed at the Gaylord factory in a cabinet mounted on the ClearAir unit (Refer to Figure 3-4-1). If this system discharges, it must be recharged by a fire extinguishing system company before the Exhaust Fan can be restarted.



Figure 3-4-1
Typical Wet Chemical Fire
Extinguishing System

Operator Maintenance

Detergent

The detergent tank should be checked at least weekly and filled with the recommended detergent Gaylord Formula G-510EF. Refer to page 4-8 for details and ordering information. Formula G-510EF is non-corrosive and will not damage the aluminum plates of the ESP Cells. **Caution;** If a detergent other than Formula G-510EF is used it must be of the type that will not harm aluminum.

Some Control Cabinets are equipped with a low detergent indicator. If so equipped, the Command Center screen will display text LOW DETERGENT if the detergent tank is empty or if the detergent pump is malfunctioning and detergent is not pumping. If the detergent tank is filled with water the detergent switch will activate as if there is no detergent. Depending upon the model of the Command Center there may be a digital display that reads LOW DETERGENT and the text alternates from FILL TANK and CHECK PUMP.

Maintenance - Spray Odor Chemical

If the ClearAir Unit is equipped with a spray odor control system, the liquid odor control chemical tank, located in a cabinet on the ClearAir unit must be kept filled. A red light mounted on the face of the Control Cabinet, or Command Center, will illuminate when the chemical tank is empty. We recommend the use of Gaylord Formula GS-710 odor control chemical. Refer to page 5-8 for details and ordering information.

Other Required Maintenance

1. Smoke Control Section. Odor control media require scheduled maintenance. Refer to Odor Control Maintenance beginning on Page 5-2
2. Odor Control Section. ESP Cells and filters require scheduled maintenance. Refer to Smoke Control Maintenance beginning on Page 4-10.
3. Exhaust Fan Section. The exhaust fan requires scheduled maintenance. Refer to Exhaust Fan Maintenance beginning on Page 6-3.

Periodic Pressure Wash or Steam Cleaning

The National Fire Protection Association Standard 96, (NFPA-96) requires all hood, ducts and fans be inspected and cleaned, if needed, at periodic intervals based on the type of cooking. If cleaning of the ClearAir Unit is required the cleaning company must be made aware of the following cautions:

Caution 1: Never use any caustic chemicals as they could damage the aluminum in the ESP Cells. If caustic chemicals are to be used, the ESP Cells must be removed and cleaned separately.

Caution 2: Some commercial hood cleaning companies blow a fire retardant chemical into hood and duct systems. Fire retardant chemicals should never be applied to any portion of the ClearAir Unit. If retardant is applied, it must be removed.

This Page Intentionally Left Blank

Smoke Control – Principle of Operation

Principle of Operation

The ClearAir Pollution Control Unit removes smoke particles by electrostatic precipitation. The principle of operation of electrostatic precipitation is actually quite basic. The electrostatic Cell is made up of a series of aluminum plates spaced approximately 1/4" (6.35mm) apart and the number of Cells used is determined by the air volume and the type of cooking equipment involved. Every other plate is energized with 5000 volts of D.C. power and the alternating plates are grounded. At the entry point of the Cell is a series of thin wires spaced approximately 4" (101.60mm) apart. These wires, referred to as ionizing wires, are energized with 10,000 volts D.C. and as the smoke particles enter the Cell and pass over the wires they receive a positive charge. As the charged particles continue through the Cell, the positive plate repels them and the negative or grounded plate attracts them. Thus, the smoke particles are collected on the negative plates. The action is efficient, safe and simple.

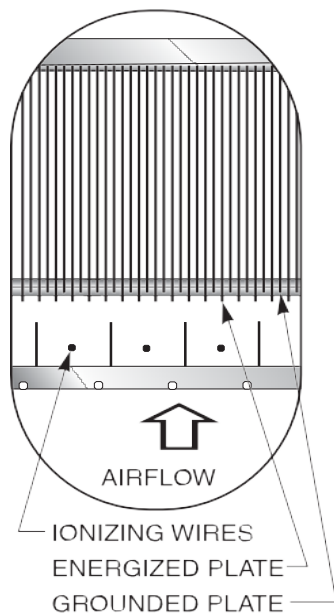

Figure 4-1-1
Electrostatic Cell
Side View

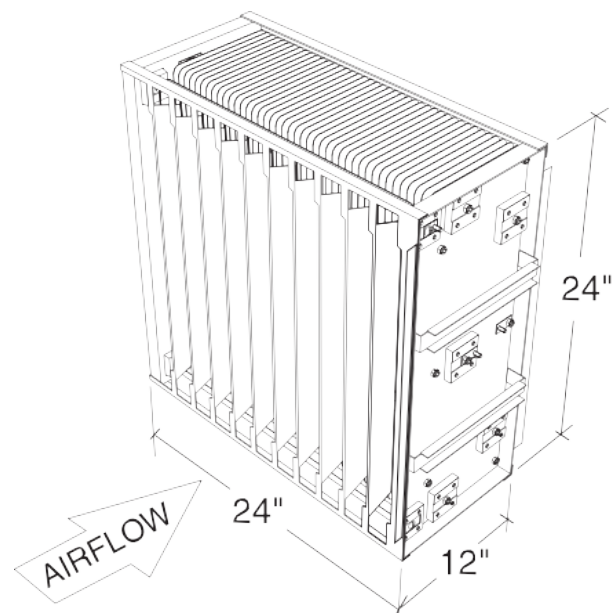

Figure 4-1-2
Electrostatic Cell
Isometric View

Smoke Control – Wash Cycle

Wash Cycle

All Gaylord ClearAir units include, as standard equipment, an internal wash down system which when activated washes the ESP Cells with hot detergent injected water to remove the daily accumulation of smoke and grease particles. If the ClearAir unit is connected to a Gaylord water wash Ventilator, the wash down systems and controls of the two are interfaced. There are two possible arrangements of controls for the operation of the Ventilator and the ClearAir Unit as illustrated on pages 2-3 and 2-4. In the first arrangement, Figure 2-3-1, the Control Cabinet in the kitchen serves both the Ventilator and the ClearAir Unit. The hot water solenoid valves, detergent pump and detergent container for both the Ventilator and ClearAir Unit are located in this cabinet. If the Ventilator is not a water wash type, then there would only be piping to the ClearAir Unit and not any to the Ventilator. In the second arrangement, Figure 2-4-1, there is a Control Cabinet for the Ventilator electrically interfaced with a Sub Panel that serves the ClearAir Unit. The hot water solenoid valves and detergent pump for the ClearAir Unit are housed in the Sub Panel and the detergent container is typically located below or next to the panel. The detergent pump and container for the Ventilator are both housed in the main Control Cabinet located in the kitchen. In both arrangements the Exhaust Fan, ClearAir Unit Wash Cycles and Fire Cycle functions are controlled by the Gaylord Command Center mounted in the main Control Cabinet. The difference between the two is the location of the plumbing components. Again, if the Ventilator is not a water wash type, then there would only be a Sub Panel and a special panel in the kitchen area containing just the Command Center (Refer to Figure 4-4-2).

The ClearAir internal wash down system consists of a series of oscillating manifolds with spray nozzles, mounted horizontally in front of the Cells, two manifolds for each horizontal row of ESP Cells (Refer to Figure 4-2-1). The manifolds are connected together with linkage, which in turn is connected to a motor which oscillates the manifolds up and down during the wash cycle (Refer to Figure 4-3-1 and 4-3-2).

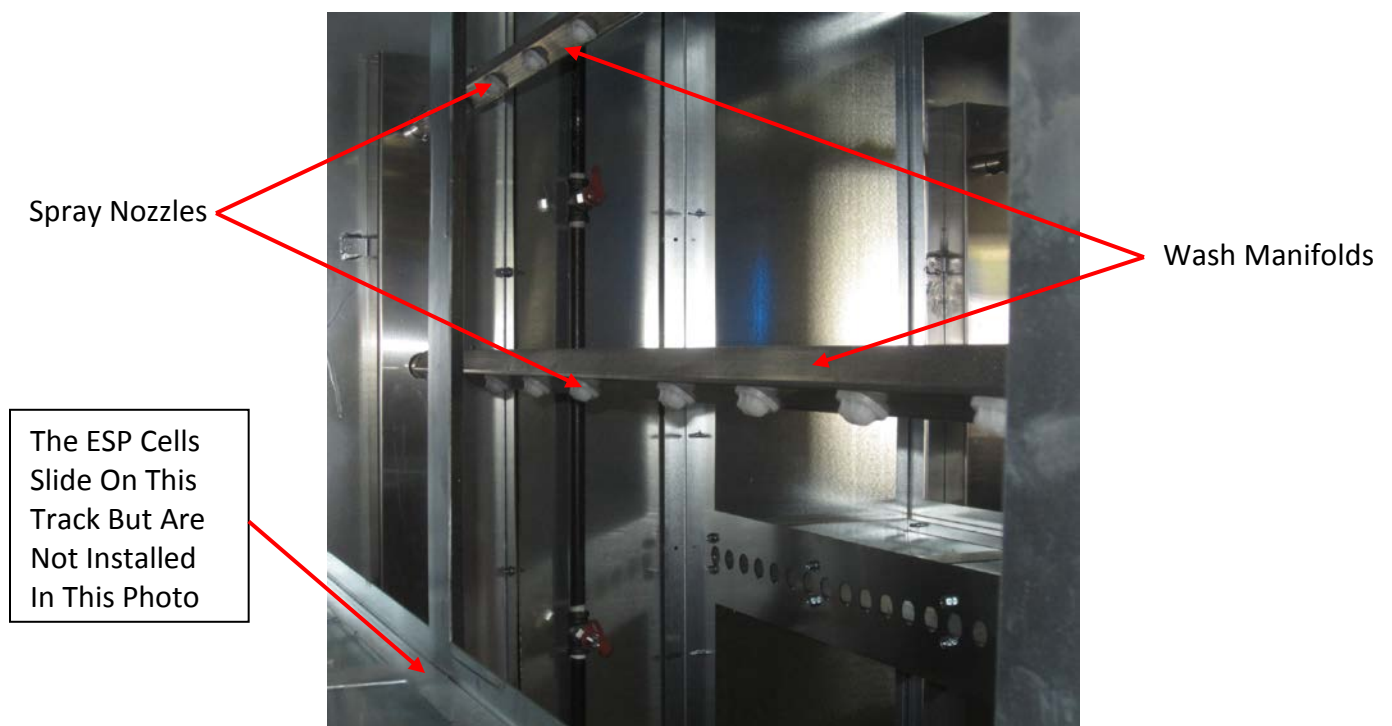

Figure 4-2-1
Typical Wash Manifolds

Smoke Control – Wash Cycle (Cont.)

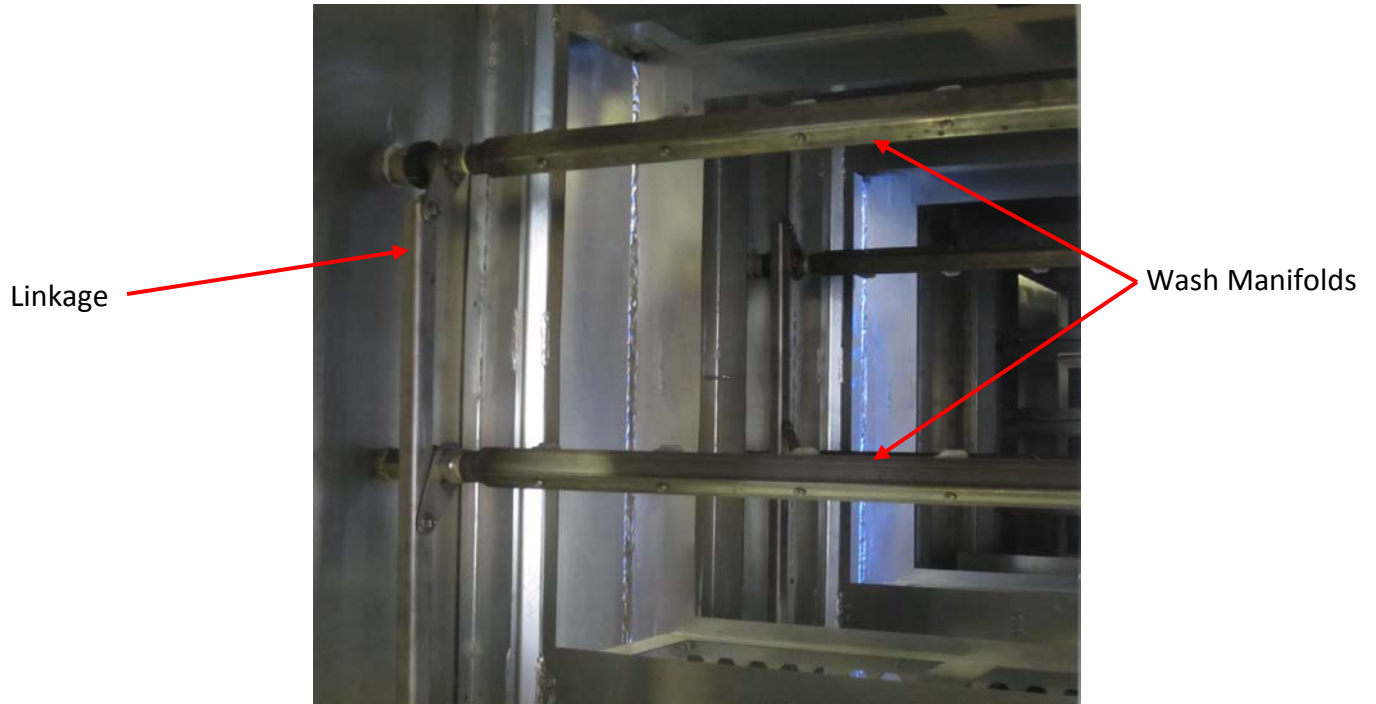

Figure 4-3-1
Manifold Linkage

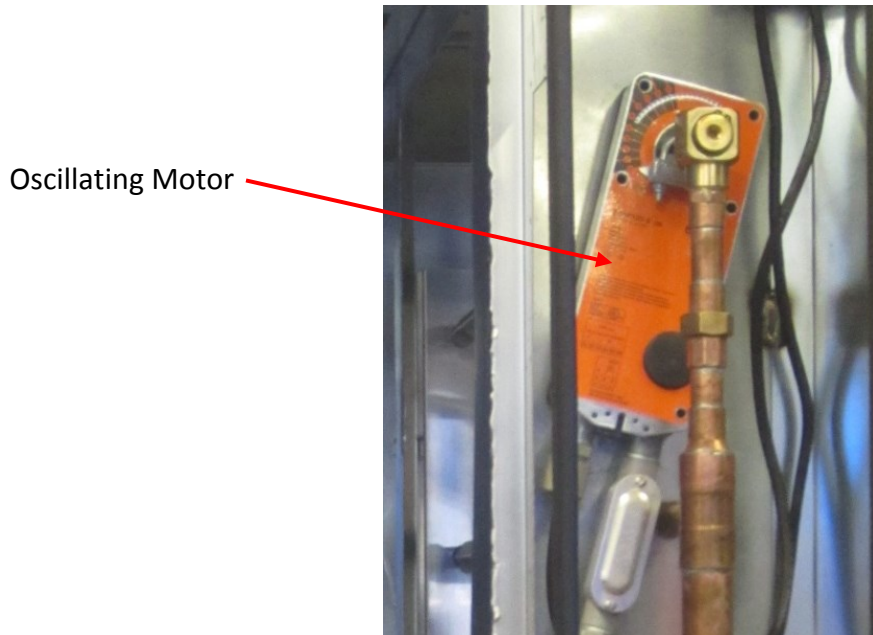

Figure 4-3-2
Oscillating Motor

Smoke Control – Wash Cycle (Cont.)

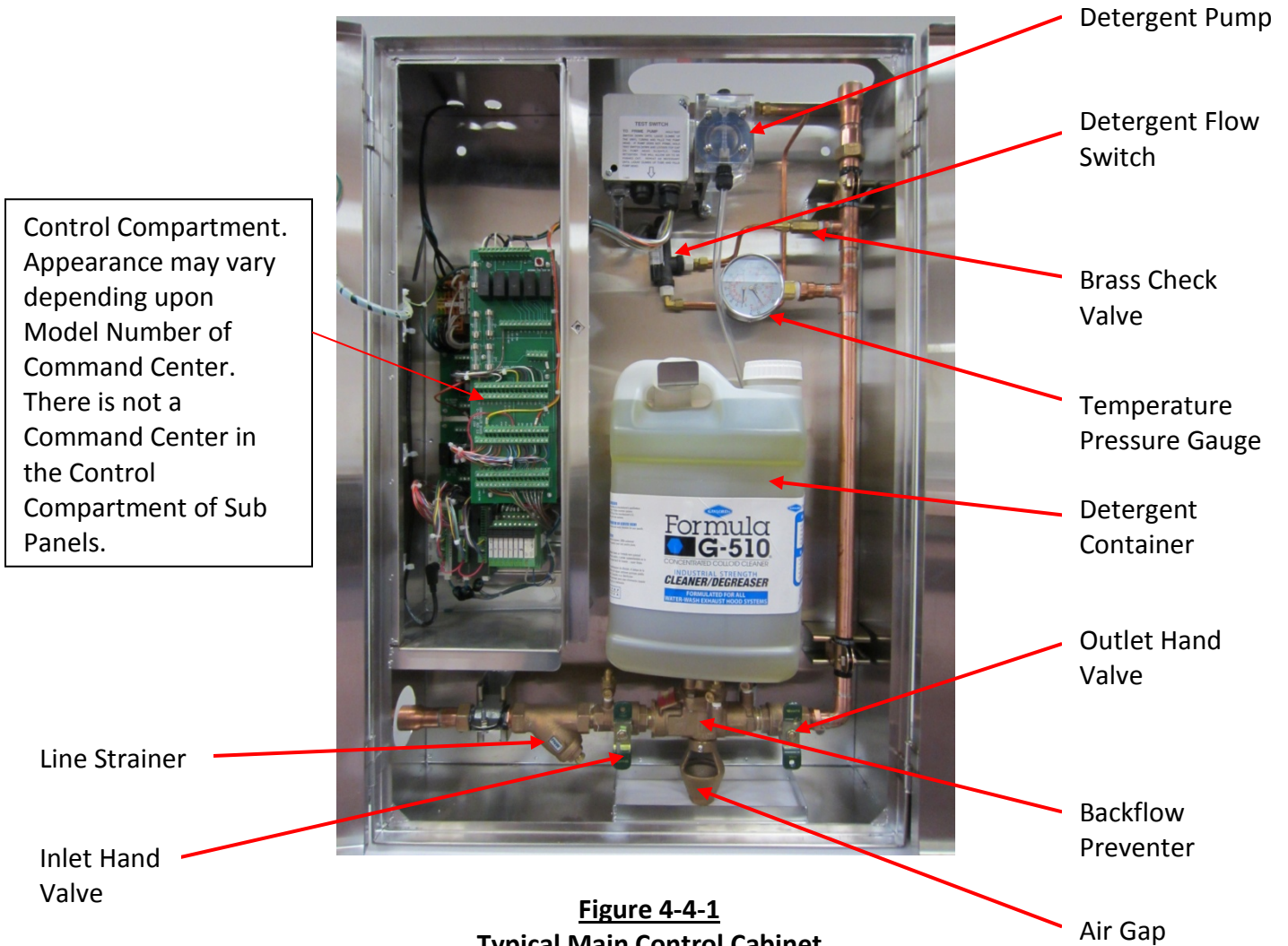
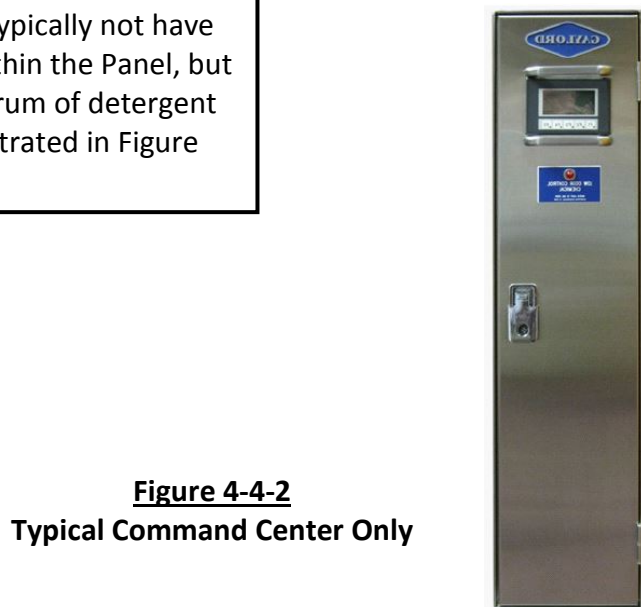

Figure 4-4-1
Typical Main Control Cabinet
(Sub Panel is the Same Except
Without Command Center)

Note: Sub Panels would typically not have a detergent container within the Panel, but would have a 55 gallon drum of detergent below the cabinet as illustrated in Figure 2-4-1.



Smoke Control – Wash Cycle (Cont.)

Wash Cycle (Cont.)

One oscillating motor controls up the four wash manifolds, two ESP Cells high. Two oscillating motors are used when the unit is three or four ESP Cells high. If the unit is a double pass, there are two complete sets of manifolds and oscillating motors, one in front of the first pass of Cells and one in front of the second pass.

From either the Main Control Cabinet or a Sub Panel there is a 1-1/4" hot water line to a pressure regulator, furnished by Gaylord, located at the water inlet of the ClearAir Unit. The pressure regulator must be set for a flow pressure of 30 psi min. – 50 psi max. There is a pressure gauge inside the plumbing compartment that houses the oscillating motor to assist in adjusting the flow pressure. This pressure is needed for the proper spray pattern to adequately wash the Cells. The minimum water temperature required is 140°F., and the maximum is 180°F. **Important Note:** The flow pressure at the Main Control Cabinet or Sub Panel must be 40 psi min. – 80 psi max.

The Wash Cycle is initiated each time the Exhaust Fan is shut off by the Command Center, either by pushing the STOP FAN button or automatically as programmed. If the ClearAir Unit is serving a water wash Ventilator, the Ventilator wash cycle always occurs first followed by the ClearAir wash cycle.

Upon initiation of the ClearAir wash cycle, the unit is washed in the following sequence:

Table T-4-5-1

<u>Wash Cycle Sequence</u> <u>Units with 1 to 16 Cells</u>
1. 3 minute wash
2. Between a 1-99 minute delay
3. 3 minute wash
4. Between a 1-99 minute delay
5. 3 minute rinse
The wash cycle is finished

Table T-4-5-2

<u>Wash Cycle Sequence</u> <u>Units with 18 to 32 Cells</u>
1. 3 minute wash
2. Between a 1-99 minute delay
3. 3 minute wash
4. Between a 1-99 minute delay
5. 3 minute wash
6. Between a 1-99 minute delay
7. 3 minute wash
8. Between a 1-99 minute delay
9. 3 minute rinse
10. Between a 1-99 minute delay
11. 3 minute rinse
The wash cycle is finished

The 3 minute wash and rinse times are the standard recommend times to be programmed in the Command Center. If the Cells are not adequately cleaned the wash cycle time may have to be increased and/or the rinse time increase to allow more soaking time. The wash and rinse cycles may be programmed for between 1-99 minutes.

The delay time between the washes and rinses are programmed in the Command Center for a length of time necessary to allow the building's hot water system to recover. The delay time may be programmed for between 1-99 minutes.

Smoke Control – Wash Cycle (Cont.)

The amount of hot water used is dictated by the number of ESP Cells. Refer to Table T-4-7-1 and T-4-7-2 for the amount of hot water used per 3 minute wash and rinse, and total water used for the entire wash cycle.

Important Note:

The wash, delay and rinse times may be programmed for different times as needed to adequately clean the ESP Cells. The Command Center illustrated in this manual may not represent the model of Command Center you have. Refer to the Technical Manual for your specific model of Command Center for complete instructions on programming wash, delay and rinse cycle times. If you do not have a Technical Manual for your Command Center, obtain the model number from the nameplate on the Command Center and contact Gaylord Industries. Refer to page 1-1 for contact information.

Smoke Control – Wash Cycle (Cont.)**Table 4-7-1**

Model RSPC-ESP-OW Series Water Consumption Chart						
Single Pass ESP Base on a Minimum Flow Pressure of 30 PSI *						
Cell Configuration W x H	# of Cells	HW Inlet Size	Total Gallons of HW for 1st 3 Minute Wash	Total Gallons of HW for 2nd 3 Minute Wash	Total Gallons of HW for 3 Minute Rinse	Total Gallons of HW for Washes and Rinse
1 x 1	1	1-1/4"	6.9	6.9	6.9	20.7
2 x 1	2	1-1/4"	13.8	13.8	13.8	41.4
3 x 1	3	1-1/4"	20.7	20.7	20.7	62.1
4 x 1	4	1-1/4"	27.6	27.6	27.6	82.8
2 x 2	4	1-1/4"	27.6	27.6	27.6	82.8
2 x 3	6	1-1/4"	41.4	41.4	41.4	124.2
2 x 4	8	1-1/4"	55.2	55.2	55.2	165.6
3 x 3	9	1-1/4"	62.1	62.1	62.1	186.3
3 x 4	12	1-1/4"	82.8	82.8	82.8	248.4
4 x 2	8	1-1/4"	55.2	55.2	55.2	165.6
4 x 3	12	1-1/4"	82.8	82.8	82.8	248.4
4 x 4	16	1-1/4"	110.4	110.4	110.4	331.2

Table 4-7-2

Model RSPC-ESP-OW Series Water Consumption Chart									
Double Pass ESP Based on Minimum Flow Pressure of 30 PSI *									
Cell Configuration Per Pass W x H	Total # of Cells	(#) of HW Inlets & Size	Total Gallons of HW for 1st 3 Minute Wash	Total Gallons of HW for 2nd 3 Minute Wash	Total Gallons of HW for 3rd 3 Minute Wash	Total Gallons of HW for 4th 3 Minute Wash	Total Gallons of HW for 1st 3 Minute Rinse	Total Gallons of HW for 2nd 3 Minute Rinse	Total Gallons of HW for Washes and Rinses
1 x 1	2	(1) 1-1/4"	13.8	13.8	No Wash	No Wash	13.8	No Rinse	41.4
2 x 1	4	(1) 1-1/4"	27.6	27.6	No Wash	No Wash	27.6	No Rinse	82.8
3 x 1	6	(1) 1-1/4"	41.4	41.4	No Wash	No Wash	41.4	No Rinse	124.2
4 x 1	8	(1) 1-1/4"	55.2	55.2	No Wash	No Wash	55.2	No Rinse	165.6
2 x 2	8	(1) 1-1/4"	55.2	55.2	No Wash	No Wash	55.2	No Rinse	165.6
2 x 3	12	(1) 1-1/4"	82.8	82.8	No Wash	No Wash	82.8	No Rinse	248.4
2 x 4	16	(1) 1-1/4"	110.4	110.4	No Wash	No Wash	110.4	No Rinse	331.2
3 x 3	18	(2) 1-1/4"	62.1	62.1	62.1	62.1	62.1	62.1	310.0
3 x 4	24	(2) 1-1/4"	82.8	82.8	82.8	82.8	82.8	82.8	414.0
4 x 2	16	(2) 1-1/4"	110.4	110.4	No Wash	No Wash	110.4	No Rinse	331.2
4 x 3	24	(2) 1-1/4"	82.8	82.8	82.8	82.8	82.8	82.8	414.0
4 x 4	32	(2) 1-1/4"	110.4	110.4	110.4	110.4	110.4	110.4	662.4

*Note: Water consumptions are 2.3 GPM per Cell based on a set flow pressure at the spray nozzle of 30 psi

Smoke Control – Wash Cycle – Recommend Detergent

Overview

Formula G-510EF is the only detergent recommended by Gaylord Industries for use in the wash down system of The Gaylord ClearAir Unit. Formula G-510EF is a concentrated colloid cleaner specially formulated to remove the daily accumulation of smoke and grease particles captured within the ESP Cells without damaging the aluminum in the Cells, or rubber and synthetic parts of the solenoid valves and the detergent pumping system. Formula G-510EF is safe for kitchen personnel and has a variety of uses.

FORMULA G-510EF Safety

FORMULA G-510EF is registered with the U.S. EPA's Design for the Environment Program (DfE) which seeks to promote the use of institutional cleaners and maintenance products with improved environmental and human health characteristics.

Formula G-510EF for the ClearAir Wash System

Pour FORMULA G-510EF directly into the detergent tank located inside the Wash Control Cabinet. The detergent pump injects the detergent into the Main Feed Line where it dilutes with the hot water at the proper ratio.

Formula G-510EF for Cleaning the Ventilator Exterior

Mix one part Formula G-510EF to twenty parts water in hand spray bottle. Spray on, let stand for a few minutes and wipe off.

Formula G-510EF for Other Cleaning Jobs

The colloidal action of Formula G-510EF makes it a cleaner especially well-suited for use in kitchens. The colloids break up dirt and grease into millions of tiny particles that constantly repel each other. These particles cannot recombine or redeposit on a surface and are, therefore, easily washed away. Formula G-510EF contains no harsh chemicals, yet offers outstanding performance on the toughest cleaning jobs.

Use a mixture of one part Formula G-510EF to twenty parts water for:

- VINYL/PLASTIC/WALLS...Removes dirt, grease, food deposits and fingerprints.
- REFRIGERATORS...Removes dirt, spilled milk, blood, mildew and objectionable odors.
- RESTROOMS...Add a disinfectant to clean all fixtures, walls, floors, etc.

Use a mixture of one part Formula G-510EF to five parts water for extremely heavy grease build-up, such as on the floor and on equipment around deep-fryers. Spray on, let set for a few minutes and rinse or wipe off. For extremely soiled areas, gentle agitation, followed by a soaking period, will result in more thorough cleaning. Don't be afraid to experiment with Formula G-510EF because it contains no phosphates, nitrates, enzymes, sulfates, suffocates or silicates.

Smoke Control – Wash Cycle – Recommend Detergent (Cont.)

Limited Warranty

2010 Products, Inc. warrants that Formula G-510EF will not cause cleansing agent damage to the ESP Cells, rubber and synthetic parts of the injection pump (“O” rings, diaphragms, washers, tubing, and other such parts) used with The Gaylord Ventilator, Heat Reclaim Unit, or Pollution Control Equipment so long as used pursuant to its product instructions. 2010 Products, Inc. obligation under this warranty and any warranties implied by law shall be limited to repairing or replacing, at its option, any of said parts which 2010 Products, Inc. examination shall disclose to its satisfaction to have been damaged by the use of Formula G-510EF for the life of the detergent pumping system. This warranty shall not cover damages caused by any other detergent. The use of any other detergent shall void this warranty. All repairs and replacement parts under this warranty shall be F.O.B. 2010 Products, Inc. The owner shall pay the necessary freight and delivery charges; also removal and installation costs. Any federal, state or local taxes are also extra. Requests for repairs or replacement part should be made to 2010 Products, Inc., P.O. Box 7609, Salem, Oregon, 97303. This is the sole warranty with respect to FORMULA G-510EF.

2010 Products, Inc. MAKES NO OTHER WARRANTY OF ANY KIND WHATSOEVER, EXPRESSED OR IMPLIED, AND ALL IMPLIED WARRANTIES OF MERCHANTABILITY AND FITNESS FOR A PARTICULAR PURPOSE WHICH EXCEED THE AFORESAID OBLIGATION ARE HEREBY DISCLAIMED AND EXCLUDED FROM THIS AGREEMENT. 2010 Products, Inc. SHALL NOT BE RESPONSIBLE FOR INCIDENTAL OR CONSEQUENTIAL DAMAGES RESULTING FROM A BREACH OF THIS WARRANTY.

IMPORTANT

If a cleansing agent other than FORMULA G-510EF is used with The Gaylord Ventilator injection pump and solenoid valves, it is recommended that a warranty similar to the above be obtained from the manufacturer of said product, that the detergent has foaming properties similar to FORMULA G-510EF and that the above-referenced Warranty shall become null and void.

Formula G-510EF Distributor

For the name and address of the nearest Formula G-510EF distributor contact:

Gaylord Industries
10900 SW Avery Street
Tualatin, OR 97062

E-mail: info@gaylordventilation.com
Website: www.gaylordventilation.com
Phone: 800-547-9696

Smoke Control - Maintenance

Proper maintenance is the key element in keeping the Gaylord ClearAir Unit operating at design efficiency. The following outlines recommended maintenance.

ESP Cell Rotation

To achieve maximum smoke removal it is recommended that the ESP Cells within the ClearAir unit be rotated out, using spare Cells provided. A soak tank (Refer to Figure 4-11-1) is recommended for each spare Cell to facilitate cleaning. Refer to Table T-4-14-4 for the recommend number of spare Cells. The frequency of rotation is based primarily on the type of cooking equipment the unit is serving, the number of hours per day of operation, hot water temperature and pressure, the type of detergent used and whether or not the Ventilator incorporates a UV system (Ultra Violet Light). The recommended Cell rotation frequency is shown in the Table T-4-10-1.

Table T-4-10-1

ESP Cell Suggested Rotation Frequency Chart		
Type of Cooking Equipment	Rotation Frequency in Days	
	Standard Hood	Hood with UV
Light Duty Ovens, Steamers and Kettles	30	365
Medium Duty Braising pans/Tilting skillets, fryers, griddles, grooved griddles, open burner ranges, hot top ranges, and conveyor ovens	21	126
Heavy Duty Gas and electric charbroilers, upright broilers, woks and conveyor broilers	14	84
Extra Heavy Duty Solid fuel broilers	7	NA*

*Ventilators with UV (Ultra Violet) systems are not used when covering Extra Heavy Duty equipment.

The number of ESP Cells a unit has is dictated by the air volume (CFM) of the unit. The illustrations on page 4-15 show the standard Cell configurations from a 1 Cell to a 16 Cell unit. There are two types of Cells, “Outer Cells” and “Inner Cells” marked “O” and “I” on the Cell configuration illustrations on page 4-15 and marked on the nameplate of the Cell (Refer to Figure 4-16-1 and 4-16-2). The differences between the two are shown on the illustrations on page 4-13. The number of “Inner” and “Outer” spare Cells provided varies with the size of the unit. Refer to the spare Cell chart C- 4-14-4. Note; Spare Cells are optional and must be ordered with the ClearAir Unit or may be ordered from the Gaylord Parts Department.

NOTE: Some units are equipped with a second row of ESP Cells, referred to as double pass and denoted in the model number by the suffix "2ESP". Additional spare Cells are not provided for double pass units as the

second pass does not get as dirty as the first pass.

Smoke Control – Maintenance (Cont.)

ESP Cell Rotation – Cont.

It is recommended that the Cells be rotated out by row (Refer to Figure 4-15-1). So, for example, if the ClearAir unit is 3 rows high, in the first rotation all the Cells in row #1 would be removed and replaced with clean spare Cells. The dirty Cells would be placed into the soak tank. At the next rotation time row #2 would be removed and replaced with the cleaned spare Cells, and then row #3. In order to have effective Cell rotation, it is important to set up the system so that you know which row of Cells is next to be rotated out. Referring to the Cell configuration illustration on page 4-15, a number has been assigned to each row. Use these numbers in developing a system for rotation. Refer to Appendix “E” for a Cell Rotation Frequency Log Chart that can be photocopied for use in developing a system for rotation.

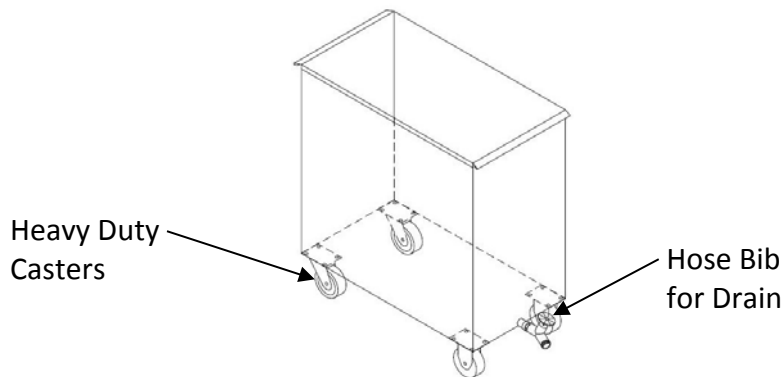

Figure 4-11-1
Cell Soak Tank

Standard Safety Voltage Test Before Removing Cells

Extreme Caution: As a standard procedure, before removing the lead wires from the ESP Cells and removing Cells, a Standard Safety Voltage Test must be conducted as described in steps 1 through 2 b) below. This test is necessary to insure that the power to the Transformer has shut off and the Grounding Disc made proper contact with the brass grounding screws to drain all the residual power from the Transformer.

1. Open the Electrical Compartment door first (the smaller door) and then the Cell/Plumbing Compartment door. Opening the Electrical Compartment door releases the Plunger Safety Switch, shutting off power to the transformer by releasing the micro switch, and draining residual power from the transformer(s) by the Grounding Disc making contact with the brass grounding screws (Refer to Figure 4-17-1 and 4-24-2).
2. To test the transformer voltage two tests must be performed the Ionizer Voltage Test and the Collector Voltage Test. To test proceed as follows:
 - a) Ionizer Voltage Test - Test the voltage from the “ION” Connection point to ground (Refer to Figure 4-12-1). If there is voltage do not proceed. Refer to the Troubleshooting Section of this manual. If there is no voltage proceed to the Collector Voltage Test.
 - b) Collector Voltage Test - Test the voltage from the “COLL” Connection point to ground (Refer to Figure 4-12-2). If there is voltage do not proceed. Refer to the Troubleshooting Section of this manual.
 - c) If there is no voltage from the tests as described in a) and b) above the lead wires may now be

removed from the ESP Cells and the Cells removed.

Smoke Control – Maintenance (Cont.)

Standard Safety Voltage Test – Cont.

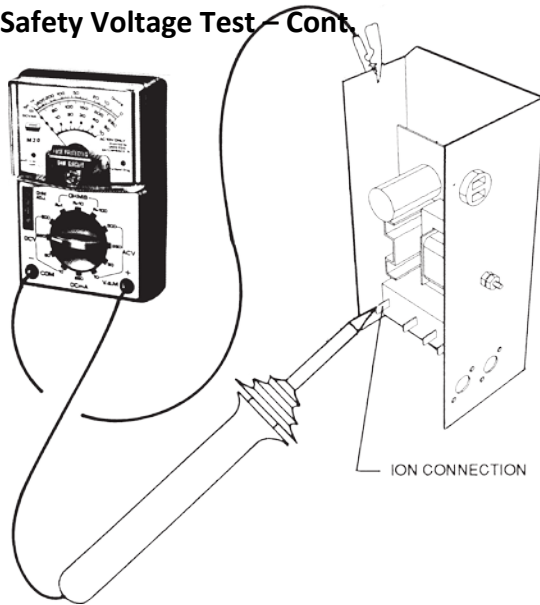

Figure 4-12-1
Ionizer Voltage Test

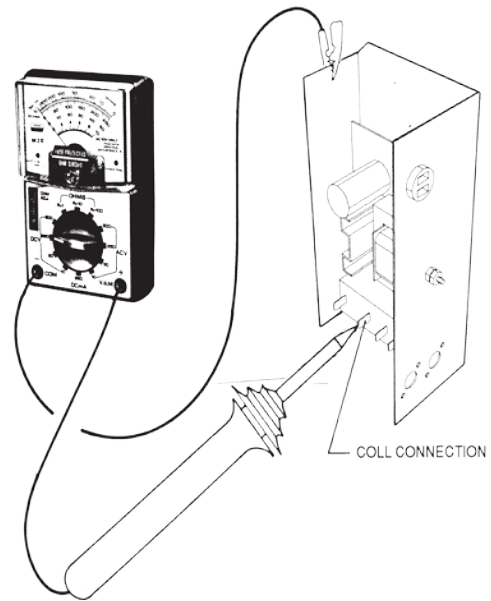

Figure 4-12-2
Collector Voltage Test

Cell Rotation Procedure

1. Once the Standard Safety Voltage Test has been conducted and there is no voltage, the Cells can be safely removed.
2. Remove the spare Cells from the soak tank and drain the water. It may be necessary to hose the tank interior to remove grease and smoke residue.
3. Remove the three (3) wires from the outer Cell by pulling forward from the Cell terminals. Route the wires up onto the Wire Hook at the top of the compartment and down the left side into the holding channel to keep out of the way while removing the Cells (Refer to Figure 4-18-1).
4. Pull all the Cells straight out slowly.

CAUTION: Each Cell weighs 53 lbs. and may be awkward to handle, particularly Cells in the upper racks rows #3 and #4. It is highly recommended that a heavy duty steel wheeled ladder be used in removing the upper Cells. Extreme care must be taken to avoid damaging the Cell. Do not grip or push on the Cell plates or the ionizer wires.

5. After the row of Cells has been removed, replace them with clean Cells taken from the soak tank. **Caution** - Be sure to replace the Cells with the airflow pointing in the same direction of airflow as marked on the front of the Cell access door. Also be sure to install the Inner Cells first, the Cells with the springs.

Smoke Control – Maintenance (Cont.)

Cell Rotation Procedure – Cont.

6. Re-connect the 3 lead wires to the terminals on the Outer Cell. Close the Cell and Electrical Compartment doors.
7. Place the dirty Cells in the soak tanks. Fill with hot water and add Formula G-510EF at a ratio of one part detergent to ten parts water. Leave the Cell in the tank until the next rotation.

Figure 4-13-1
Outer Cell
End View

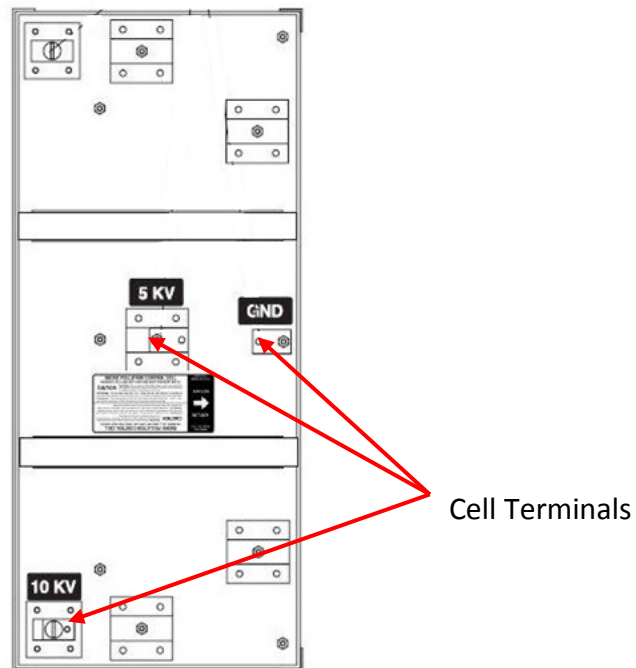
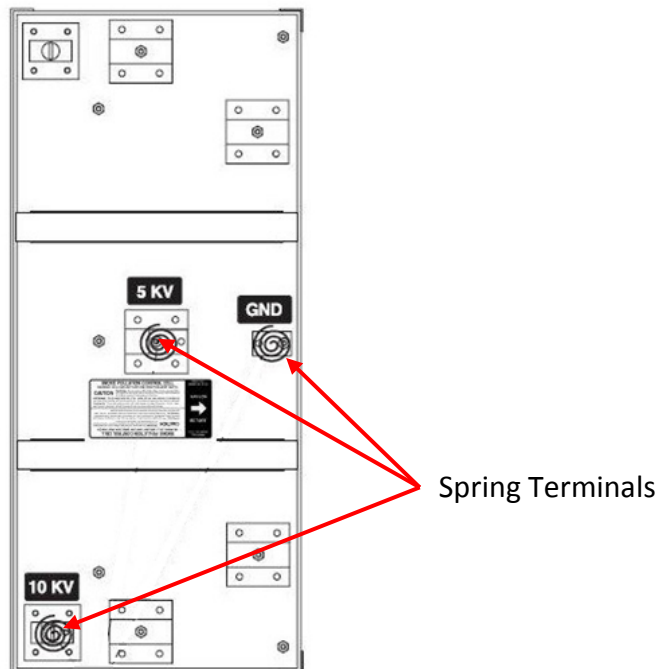

Figure 4-13-2
Inner Cell
End View



Smoke Control – Maintenance (Cont.)

Figure 4-13-3
Typical Outer Cell
Inner Cell with Springs
Not Shown

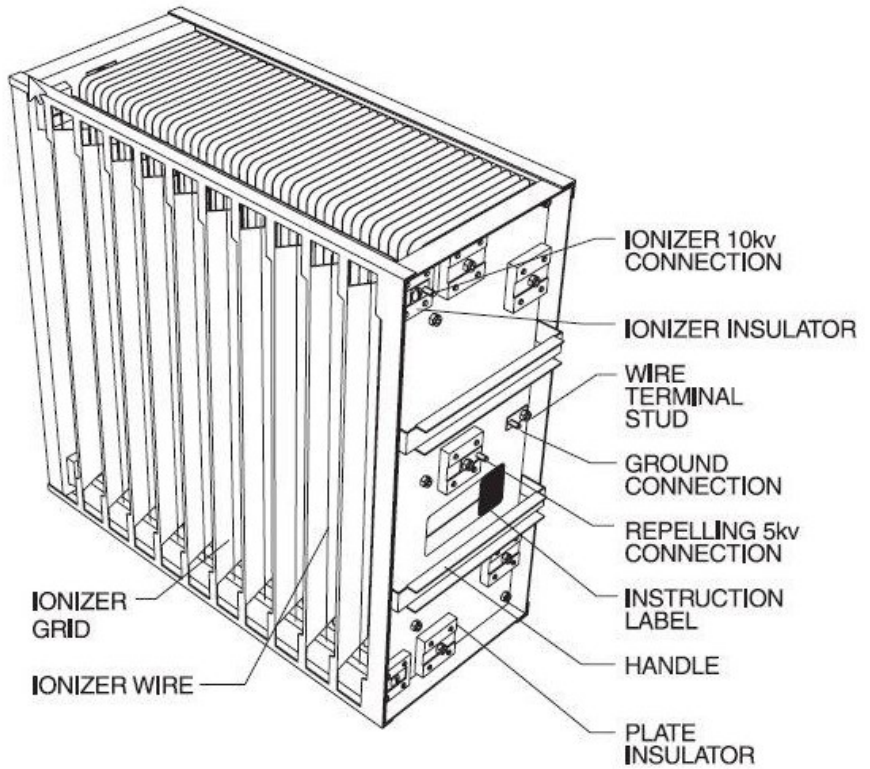

Table T-4-14-1

Size of Unit	Spare Cells	
	Outer Cell	Inner Cell
1 Cell Unit	1	0
2 Cell Unit	1	1
3 Cell Unit	1	2
4 Cell Unit	1	3
6 Cell Unit	1	2
8 Cell Unit	1	3
9 Cell Unit	1	2
12 Cell Unit	1	3
16 Cell Unit	1	3

Note: Some units are equipped with a second row of ESP Cells, referred to as double pass. Additional spare cells are not recommended for double pass units as the second pass does not get as dirty as the first pass.

Smoke Control – Maintenance (Cont.)

Figure 4-15-1
Cell Configuration

The following illustrations show the standard Cell configurations. The # 1 row is always the bottom row. The Outer Cell, (O) is always the first Cell next to the Cell access door.

O = Outer Cell
I = Inner Cell
(WxH)

Row #

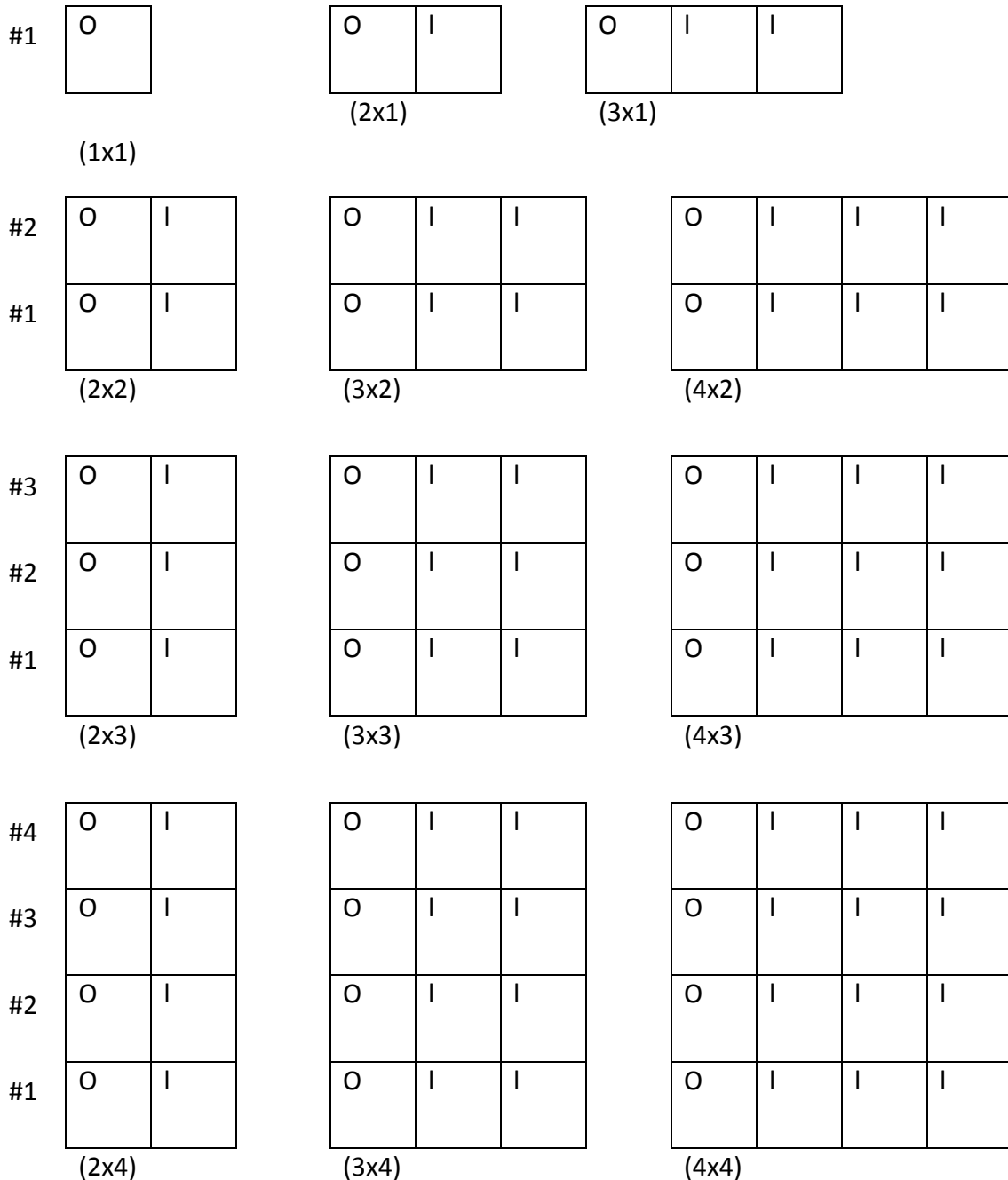

Smoke Control – Maintenance (Cont.)

Cell Identification

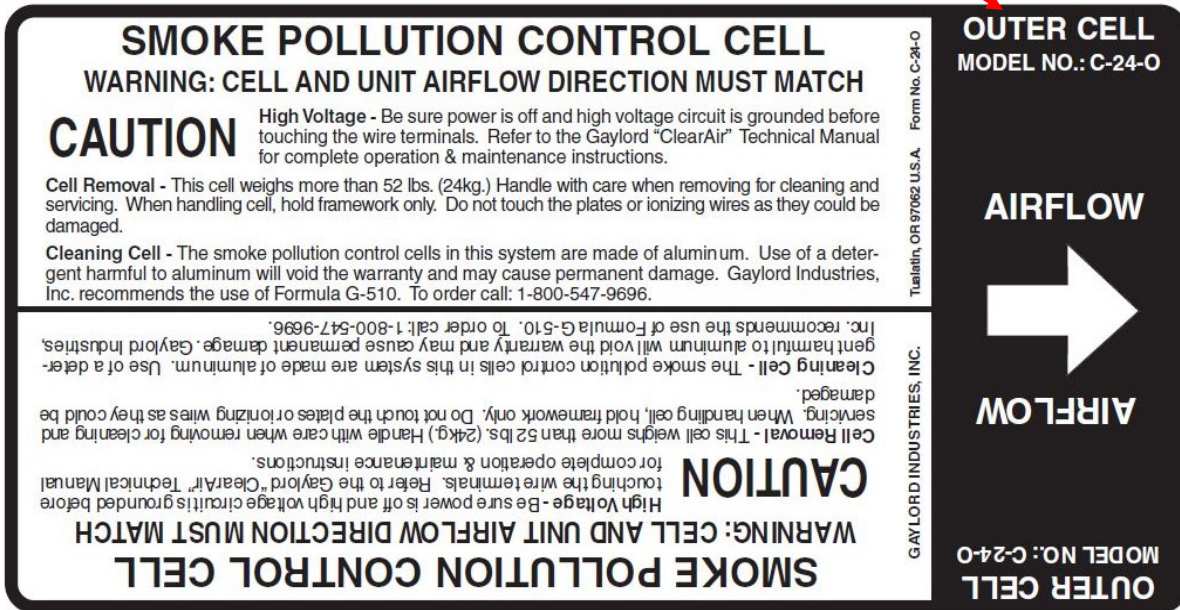

Figure 4-16-1
Outer Cell Nameplate

Cell Identification

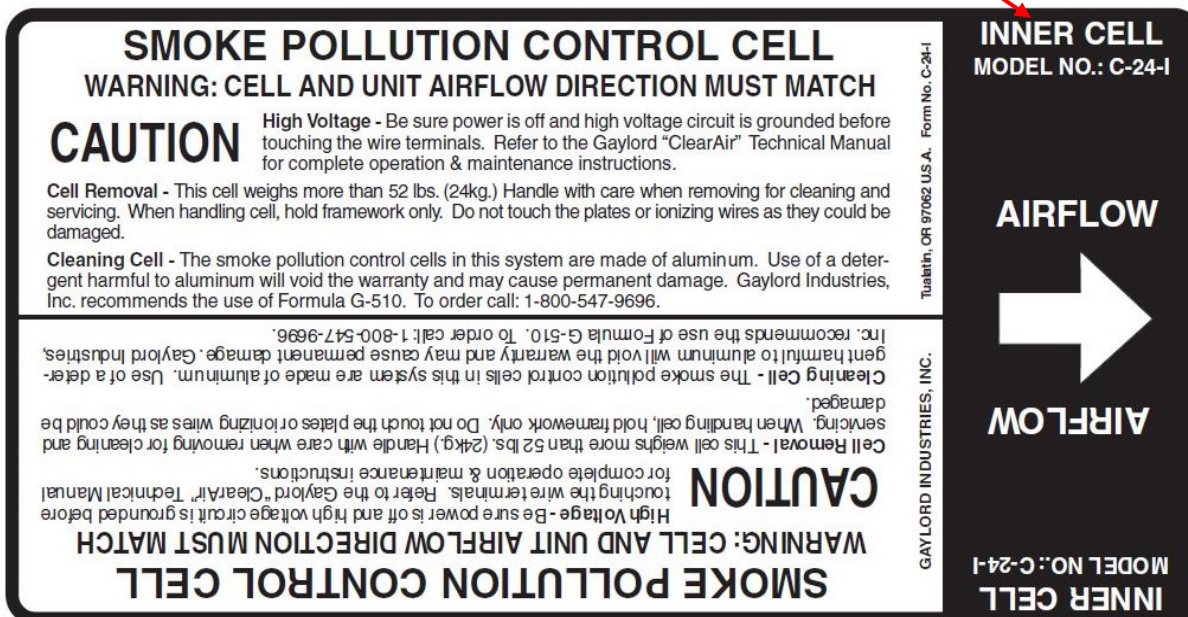

Figure 4-16-2
Inner Cell Nameplate

Smoke Control – Maintenance (Cont.)

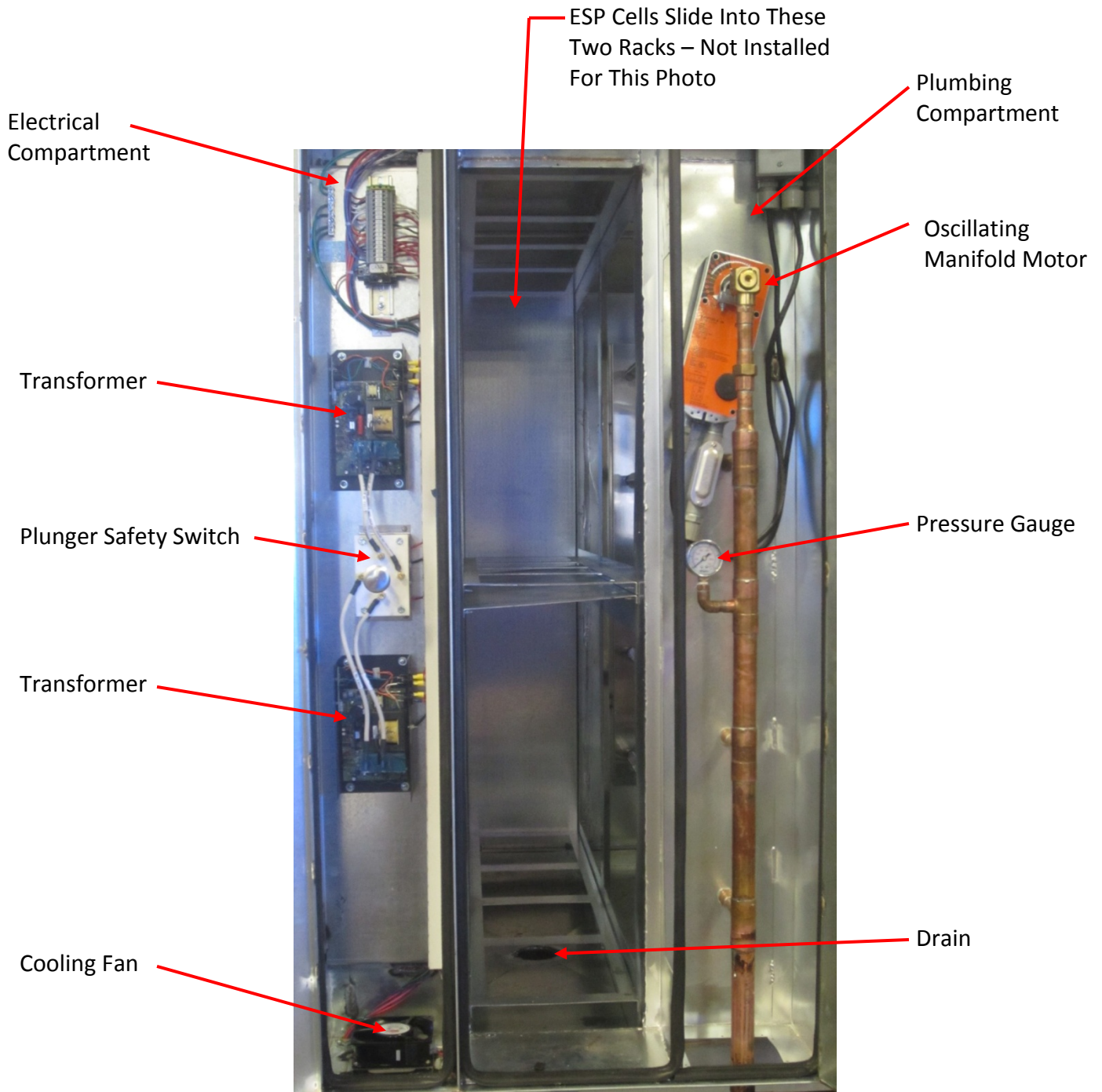

Figure 4-17-1
Electrical/Cells/Plumbing
Compartments with Doors Opened

Smoke Control – Maintenance (Cont.)

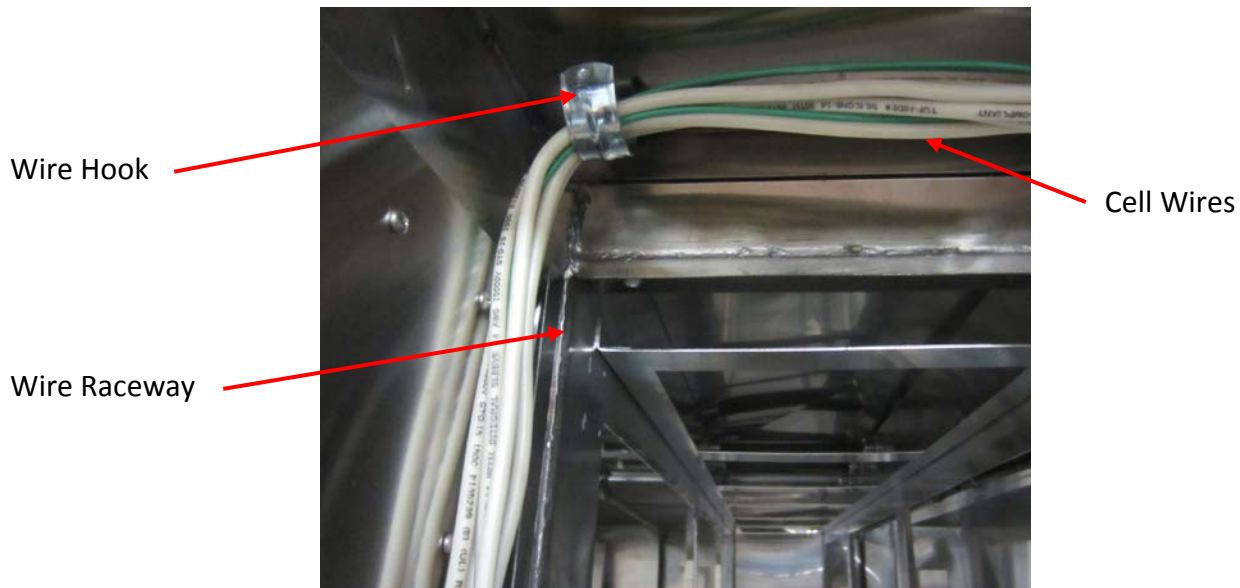

Figure 4-18-1
Cell Wires Holding Terminals

Filter Maintenance

The ClearAir unit is equipped with debris screens or impactor filters located prior to the ESP Cells. It also includes moisture separator filters immediately after the ESP Cells. All these filters are washable and should be washed using the same frequency as the ESP Cell rotation as shown in the Cell Rotation Table T-4-10-1 on page 4-10.

Weekly Maintenance

Detergent The detergent tank should be checked at least weekly and filled with the recommended detergent Gaylord Formula G-510EF. Refer to page 4-8 for details and ordering information. Formula G-510EF is non-corrosive and will not damage the aluminum plates of the ESP Cells. **Caution;** If a detergent other than Formula G-510EF is used it must be of the type that will not harm aluminum.

Some Control Cabinets are equipped with a low detergent indicator. If so equipped, a green light mounted on the face of the Control Cabinet will flash if the detergent tank is empty or if the detergent pump is malfunctioning and detergent is not pumping. If the detergent tank is filled with water the detergent switch will activate as if there is no detergent. Depending upon the model of the Command Center there may be a digital display that reads LOW DETERGENT and the text alternates from FILL TANK and CHECK PUMP.

Spray Odor Chemical If the ClearAir Unit is equipped with a spray odor control system, the liquid odor control chemical tank, located in a cabinet on the ClearAir unit must be kept filled. A red light mounted on the face of the Control Cabinet, or Command Center, will illuminate when the chemical tank is empty. We recommend the use of Gaylord Formula GS-710 odor control chemical. Refer to page 5-8 for details and ordering information.

Smoke Control – Maintenance (Cont.)

Six Month Maintenance

Every 6 months remove and inspect the ESP Cells and check the following:

Extreme Caution: Before removing the lead wires from Cells, a Standard Safety Voltage Test must be conducted as described on page 4-11. This test is necessary to insure that the Grounding Disc made proper contact with the brass grounding screws to drain all the residual power from the transformer.

1. Initiate a wash cycle and check all the spray nozzles to ensure that they are spraying properly. Also check to see that the wash manifolds are oscillating up and down.
2. Examine the ESP Cells for the following:
 - a. Check for any missing or loose ionizer wires. Replace wires as necessary. Refer to the Troubleshooting Section page 4-30 for instructions.
 - b. Check for any physical damage to the collector plates. Plates can become bent at their corners and must be straightened to maintain proper plate spacing (Refer to page 29).
 - c. Check for any grease film build-up on the high voltage insulators (white porcelain material). Clean the insulators to avoid possible high voltage “tracking” to the ground.
 - d. Check for any material which has lodged or built up between adjacent plates.

Periodic Pressure Wash or Steam Cleaning

The National Fire Protection Association Standard 96, (NFPA-96) requires all hood, ducts and fans be inspected and cleaned, if needed, at periodic intervals based on the type of cooking. If cleaning of the ClearAir Unit is required the cleaning company must be made aware of the following cautions:

Caution 1: Never use any caustic chemicals as they could damage the aluminum in the ESP Cells. If caustic chemicals are to be used, the ESP Cells must be removed and cleaned separately.

Caution 2: Some commercial hood cleaning companies blow a fire retardant chemical into hood and duct systems. Fire retardant chemicals should never be applied to any portion of the ClearAir Unit. If retardant is applied, it must be removed.

Periodic Pressure Wash or Steam Cleaning Note: When pressure washing or steam cleaning a majority of the water will drain out the drain located in the ESP Cell compartment. Additional water may be drained by removing the drain plug on the additional drain located on the side of the unit (Refer to Figure 4-19-1).

Figure 4-19-1
Drain Plug

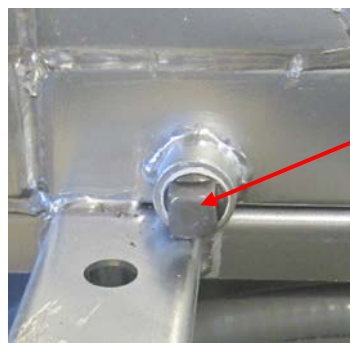

Drain Plug

Smoke Control – Troubleshooting

Overview

Proper voltage through the ESP Cells is essential for maximum smoke removal. There is one or more power supply Transformers located in the electrical compartment of the ClearAir unit (Refer to Figure 4-17-1). The quantity is dictated by the number of Cells, but typically there is one transformer(s) for every row of Cells. The transformer(s) outputs 5,000 volts DC to the repelling plates of the Cell and 10,000 volts DC to the ionizing wires. The voltage of each transformer is monitored by a green status light located on the main Control Cabinet, and on the electrical compartment door of the ClearAir unit (Refer to Figure 3-2-1). A solid green light indicates that the ESP Cells are operating properly.

Using the Troubleshooting Charts

The following Troubleshooting Charts are designed to easily find common problems, the probable cause and guidance on corrective action. In some cases the Corrective Action column will reference specific pages for additional guidance and corrective action.

Chart C-4-20-1

Troubleshooting Smoke Control – ESP Cells		
Symptom	Probable Cause	Corrective Action
Fluctuating green monitor light.	1. Normally this is a temporary condition, lasting until the Cells are dry, immediately following a wash cycle.	None required.
Green light off.	1. Door Safety Switch in the disconnect position.	1. Check the Cell and electrical compartment access doors to ensure that they are closed and latched.
	1. Faulty Door Safety Switch.	1. Refer to Testing Door Safety Switch instructions on Page 4-23.
	1. Plunger Safety Switch Failure.	1. Refer to Testing Plunger Safety Switch instructions on page 4-24.
	1. Voltage not getting to the Cells.	1. Check to ensure that all lead wires are connected to the Cells. 2. Check to ensure that all outer Cells are pushed in tight against the inner Cells.
	1. Possible Transformer failure.	1. Refer to Testing Transformer Voltage on page 4-25

Smoke Control – Troubleshooting (Cont.)**Chart C-4-21-1**

Troubleshooting Smoke Control – ESP Cells (Cont.)		
Symptom	Probable Cause	Corrective Action
Green light off (cont.)	1. Faulty Cell. Possible causes are: <ol style="list-style-type: none"> a. Grease build up on plates or porcelain insulators. b. Foreign material lodged between plates. c. Broken Ionizer wire. 	For all three possible causes first perform the tests following the test flow chart on page 4-22. <ol style="list-style-type: none"> 1. Remove any foreign material between Cell plates. 2. Remove grease buildup by cleaning or replace the Cell. Replace missing or broken ionizing wires following the instructions on page 4-30.

Smoke Control – Troubleshooting

Green ESP Light Off Condition

Use the following flow chart as a guide to troubleshoot a green light off condition. Then refer to the specific test procedures.

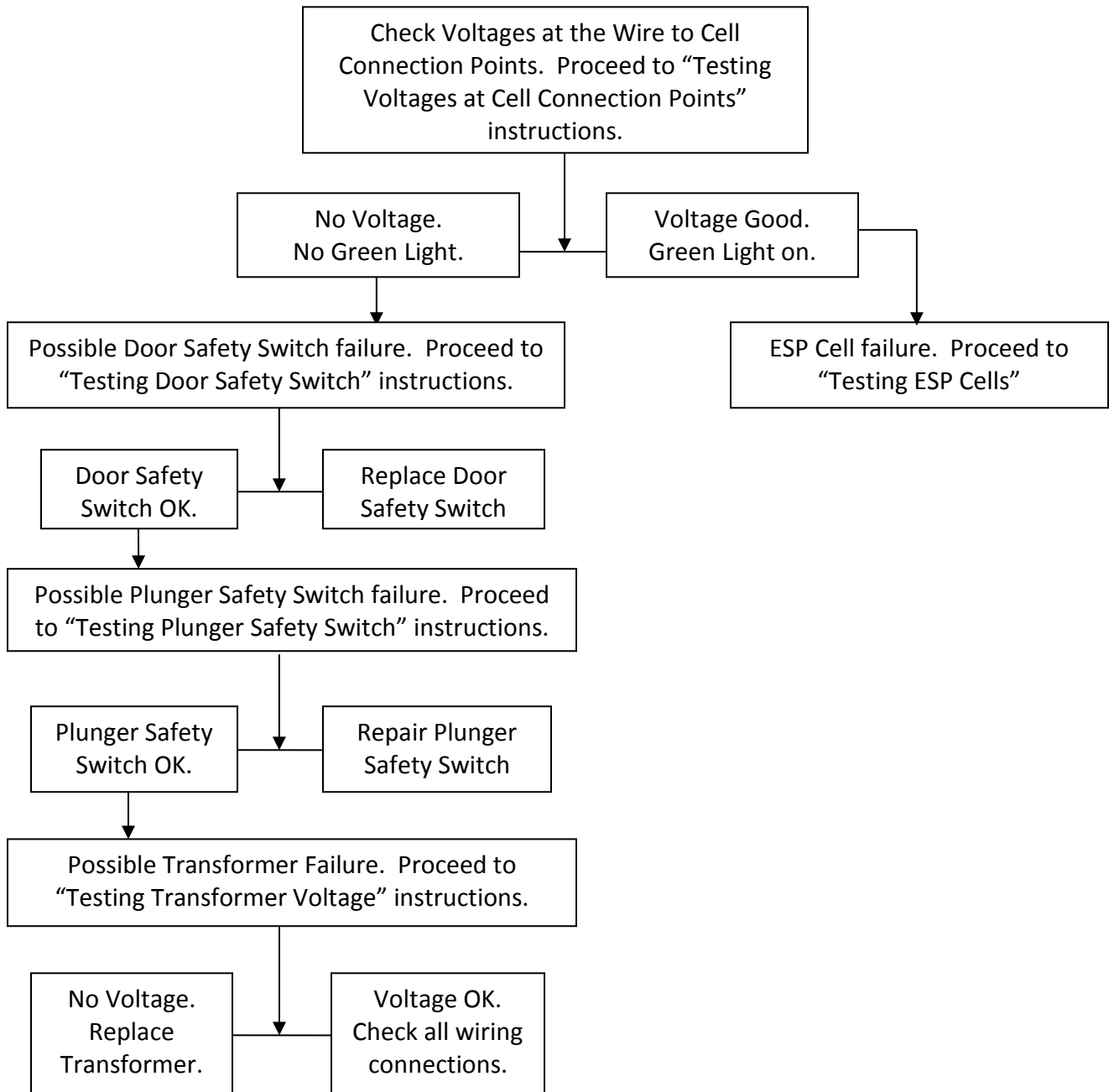

Smoke Control – Troubleshooting (Cont.)

Testing Voltages at the Cell Connection Points

To check for proper voltages, proceed as follows:

1. Open the Electrical Compartment door first (the smaller door) and then the Cell/Plumbing Compartment door. Opening the Electrical Compartment door releases the Plunger Safety Switch, shutting off power to the transformer by releasing the micro switch, and draining residual power from the transformer(s) by the Grounding Disc making contact with the brass grounding screws (Refer to Figure 4-17-1, 4-24-1 and 4-24-2).

Extreme Caution: Before removing the lead wires from Cells, a Standard Safety Voltage Test must be conducted as described on page 4-11. This test is necessary to insure that the Grounding Disc made proper contact with the brass grounding screws to drain all the residual power from the transformer.

2. Once the Standard Safety Voltage Test has been conducted, remove the 5KV and 10KV volt lead wires from the first Cell.
3. Push in and tape the Door Safety Switch in the closed position (Refer to Figure 4-23-2).
4. Connect the ground wire of the meter to the ground lead wire.
5. By hand, push in and hold the Plunger Safety Switch. The green light should be on. Now measure voltage from ground to the 5KV volt lead wire and then from ground to the 10KV volt lead wire. If proper voltage is obtained it indicates an ESP Cell failure. Proceed to “Testing ESP Cells” instructions. If there is no voltage it indicates a possible failure of the Door Safety Switch, Plunger Safety Switch, or transformer. Following the flow chart on Page 4-22, proceed to “Testing Door Safety Switch” instructions.

Testing Door Safety Switch

To check for proper operation of the Door Safety Switch proceed as follows:

1. Shut off the electrical power by turning the Disconnect Switch on the Main Electrical Panel (Refer to Figure 4-23-1).
2. Open the Electrical Compartment door first (the smaller door) and then the Cell/Plumbing Compartment door.
3. Push in the Door Safety Switch, and using a continuity tester test for continuity between terminals 43 and 5R on the terminal block. If there is continuity the Door Safety Switch is good and proceed to “Testing Plunger Safety Switch” instructions. If there is no continuity the switch must be replaced.



Figure 4-23-1
Main Electrical Panel

Door Safety Switch
Disconnect Switch

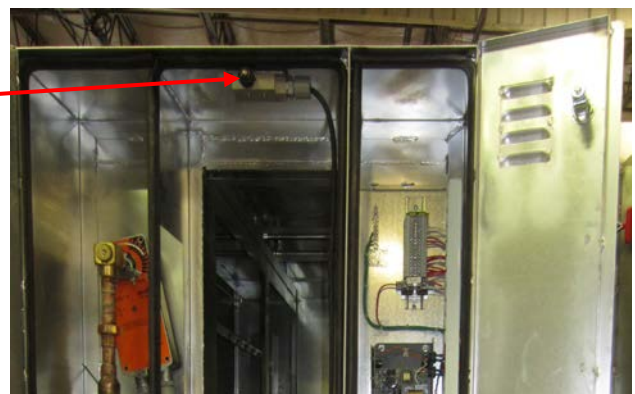

Figure 4-23-2
Cell/Plumbing and Electrical Compartments

Smoke Control – Troubleshooting (Cont.)

Testing Plunger Safety Switch

1. There is one or more Plunger Safety Switch located in the Electrical Compartment (Refer to Figure 4-17-1 and 4-24-1). The Plunger Safety Switch, when released by opening the Electrical Compartment door, shuts off the power to the power supply transformer and bleeds power from the transformer, by the Grounding Disc making contact with the brass grounding screws (Refer to Figure 4-17-1, 4-24-1 and 4-24-2). There are two potential areas that can cause failure of the Plunger Safety Switch. The first is a mechanical failure and the second is a failure of the micro switch (Refer to Figure 4-24-1). To test for these two situations proceed as follows:

Testing for Mechanical Failure

1. Turn off the power to the ESP Cells by turning the Disconnect Switch on the ClearAir Main Electrical Panel to the off position (Refer to Figure 4-23-1).
2. Open the Electrical Compartment access doors.
3. Push in the Plunger Safety Switch and verify that the Grounding Disc is pushing the micro switch down until you can hear the click of the switch engaging (Refer to Figure 4-24-2). If it is not repair as necessary. If it is working properly proceed to step #4.

Testing for Micro Switch Failure

1. Push in the Plunger Safety Switch, and using a continuity tester test for continuity between the “Common” (COM) and the “Normally Open” (NO) terminals of the micro switch (Refer to Figure 4-24-2). If there is continuity the micro switch is good. If there is not continuity the micro switch must be replaced.

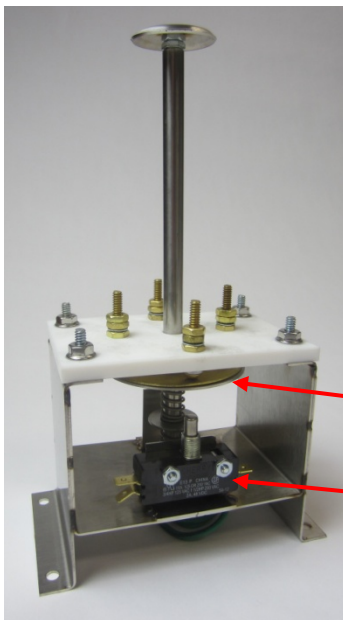

Figure 4-24-1
**Plunger Safety Switch
Not Pushed In Position**

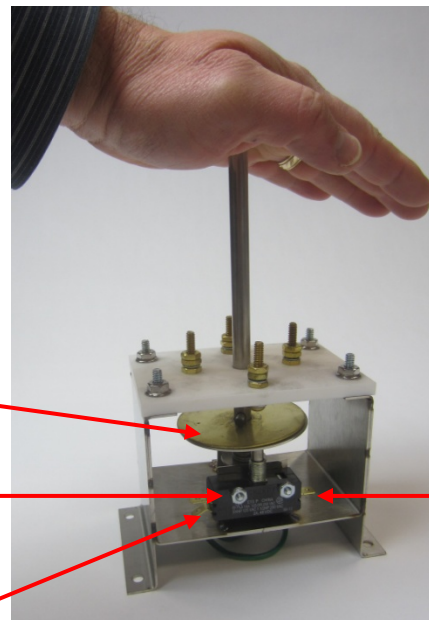

Figure 4-24-2
**Door Safety Switch
Pushed in Position**

Grounding Disc

Micro Switch

NO
Terminal

COM
Terminal

Smoke Control – Troubleshooting (Cont.)

Transformer Voltage Test

Extreme Caution: Before removing the lead wires from the Transformer a Pre-Transformer Voltage Test must be conducted as described in steps 1 and 2 below. This test is necessary to insure that the power to the Transformer has shut off and the Grounding Disc made proper contact with the brass grounding screws to drain all the residual power from the Transformer.

To test the transformer voltage two tests must be performed the Ionizer Voltage Test and the Collector Voltage Test. Prior to performing these two tests power must be shut off to the Transformer. To shut off the power proceed as follows:

1. Open the Electrical Compartment door first (the smaller door) and then the Cell/Plumbing Compartment door. Opening the Electrical Compartment door releases the Plunger Safety Switch, shutting off power to the transformer by releasing the micro switch, and draining residual power from the transformer(s) the by Grounding Disc making contact with the brass grounding screws (Refer to Figure 4-17-1 and 4-24-1).
2. To test proceed as follows:
 - A. Ionizer Voltage Test

- 1) Disconnect the high voltage wires from the power supply points “COLL” and “ION” (Refer to Figure 4-26-1 and 4-26-2).
- 2) Set selector switch on volt meter to the highest DCV scale.
- 3) Tape the Door Safety Switch closed.
- 4) Push in and hold the Plunger Safety Switch
- 5) Place probe or clip labeled "common" against “ground”.
- 6) Place high voltage probe against the “ION” connection point.
- 7) Voltage should be 9,000 to 11,000 DC.

If voltage is below 9,000, it indicates that the Transformer is defective and must be replaced. Refer to the Parts Chapter of this manual.

Smoke Control – Troubleshooting (Cont.)

Transformer Voltage Test – (Cont.)

B. Collector Voltage Test

- 1) Disconnect the high voltage wires from the power supply points “COLL” and “ION” (Refer to Figure 4-26-1 and 4-26-2).
- 2) Set selector switch on volt meter to the highest DCV scale.
- 3) Tape the Door Safety Switch closed.
- 4) Push in and hold the Plunger Safety Switch.
- 5) Place probe or clip labeled "common" against “ground” connection on the power supply. Place high voltage probe against the “COLL” connection point. Voltage should be 4,700 to 5,500 DC.

If voltage is below 4,700, it indicates that the power supply module is defective and must be replaced. Refer to the Parts Chapter of this manual.

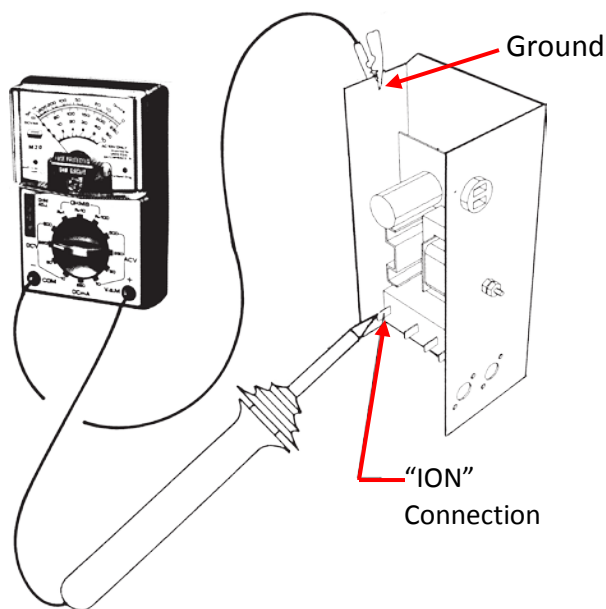

Figure 4-26-1
Ionizer Voltage Test

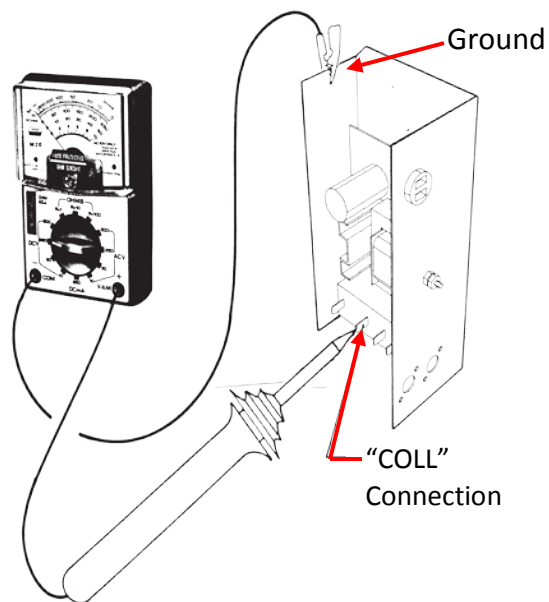

Figure 4-26-2
Collector Voltage Test

Smoke Control – Troubleshooting (Cont.)

Testing ESP Cells

To check for proper operation of each Cell, proceed as follows:

Note: The lack of a Green light may be caused by more than one Cell failing. It is recommended that the following tests be conducted on all Cells.

Testing Outer Cells

1. Open Electrical Compartment and Cell/Plumbing Compartment doors.

Extreme Caution: Before removing the lead wires from Cells, a Standard Safety Voltage Test must be conducted as described on page 4-11. This test is necessary to insure that the Grounding Disc made proper contact with the brass grounding screws to drain all the residual power from the transformer.

2. Leaving all the Cell lead wires connected, pull all the first Cells (Outer Cells) out about 4”.
3. Push in and tape the Door Safety Switch in the closed position.
4. By hand, push in Plunger Safety Switch and hold (Refer to Figure 4-24-2). Now measure voltage from ground on the Cell to the 5KV volt connection point. Voltage should be between 4,700 and 5,500 volts DC. If proper voltage is not obtained it indicates that the Cell Plates are shorting out. Proceed to “Shorting Cell Plates” instructions on page 4-29.
5. Then measure the voltage from ground on the Cell to the 10KV volt connection point. Voltage should be between 9,000 and 11,000 volts DC. If proper voltage is not obtained it indicates an Ionizing Wire is broken. Proceed to “Replacing Ionizing Wires” instructions on page 4-30.
6. Perform steps #3, #4 and #5 on each outer Cell.

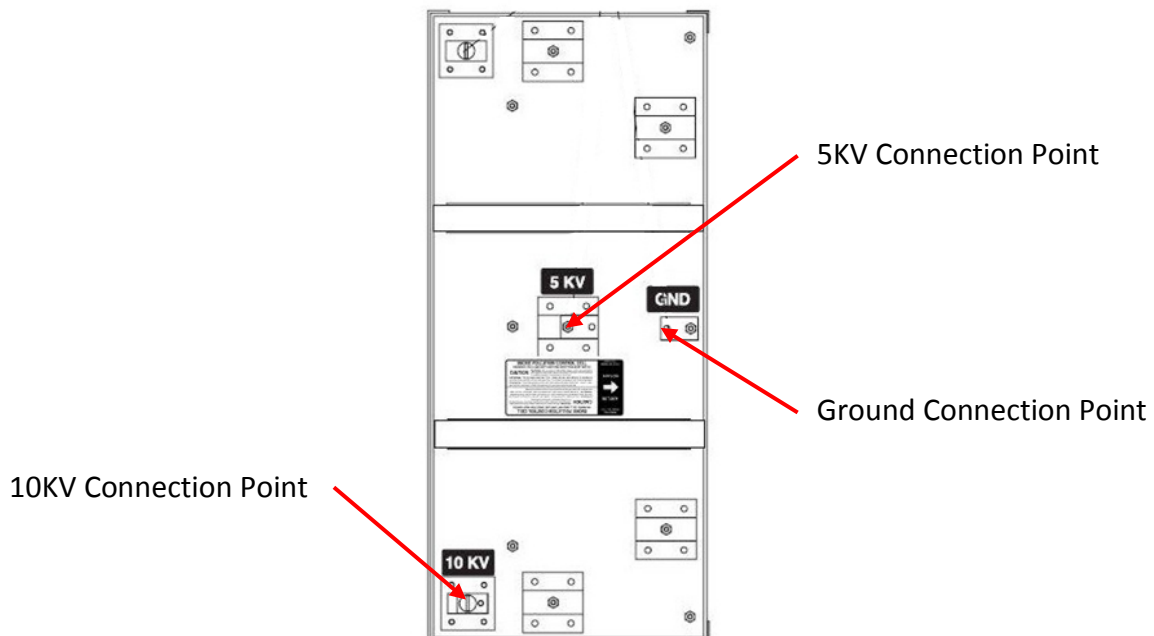

Figure 4-27-1
Outer Cell - End View

Smoke Control – Troubleshooting (Cont.)

Testing Inner Cells

Note: the next set of tests requires two test wires with an alligator clip on each end.

Note: the next set of tests requires removal of all the Inner Cells. ClearAir units wider than 2 Cells wide the 3rd and 4th Cells are difficult to remove without the use of a long handled tool. A common garden hoe makes an excellent tool for this purpose.

1. Open Electrical Compartment and Cell/Plumbing Compartment doors.

Extreme Caution: Before removing the lead wires from Cells, a Standard Safety Voltage Test must be conducted as described on page 4-11. This test is necessary to insure that the Grounding Disc made proper contact with the brass grounding screws to drain all the residual power from the transformer.

2. Once the Standard Safety Voltage Test has been conducted, remove all lead wires from the Outer Cells by pulling forward from the Cell terminals. Route the wires up onto the Wire Hook at the top of the compartment and down the left side into the Holding Channel to keep out of the way while removing the Cells (Refer to Figure 4-18-1).

CAUTION: Each Cell weighs 53 lbs. and may be awkward to handle, particularly Cells in the upper racks rows #3 and #4. It is highly recommended that a heavy duty steel wheeled ladder be used in removing the upper Cells. Extreme care must be taken to avoid damaging the Cell. Do not grip or push on the Cell plates or the ionizer wires.

3. Remove all the Outer Cells and place off to the side.
4. Slide all the first set of Inner Cells to the Cell opening. Attach one end of an alligator clip wire to the Grounding spring connection point on the Cell and the other end to the end of the Ground lead wire (Refer to Figure 4-29-1).
5. Attached one end of an alligator clip wire to the 5KV spring connection point on the Cell and the other end to the end of the 5KV lead wire (Refer to Figure 4-29-1).
6. By hand, push in the Plunger Safety Switch and hold. Now measure voltage from ground on the Cell to the 5KV volt connection point. Voltage should be between 4,700 and 5,500 volts DC. If proper voltage is not obtained it indicates that the Cell Plates are shorting out. Proceed to “Shorting Cell Plates” instructions on page 4-29.
7. Release the Plunger Safety Switch and check for voltage before removing the alligator clip from the 5KV spring connection point.
8. Attached one end of the alligator clip wire to the 10KV spring connection point on the Cell and the other end to the end of the 10KV lead wire.
9. By hand, push in Plunger Safety Switch and hold. Now measure voltage from ground on the Cell to the 10KV volt connection point. Voltage should be between 9,000 and 11,000 volts DC. If proper voltage is not obtained it indicates an Ionizing Wire is broken. Proceed to “Replacing Ionizing Wires” instructions on page 4-30.
10. Release the Plunger Safety Switch and check for voltage before removing the alligator clip from the Ground and the 10KV spring connection point.
11. Repeat steps #4 through #10 for any additional set of Inner Cells.

Smoke Control – Troubleshooting (Cont.)

Testing Inner Cells – (Cont.)

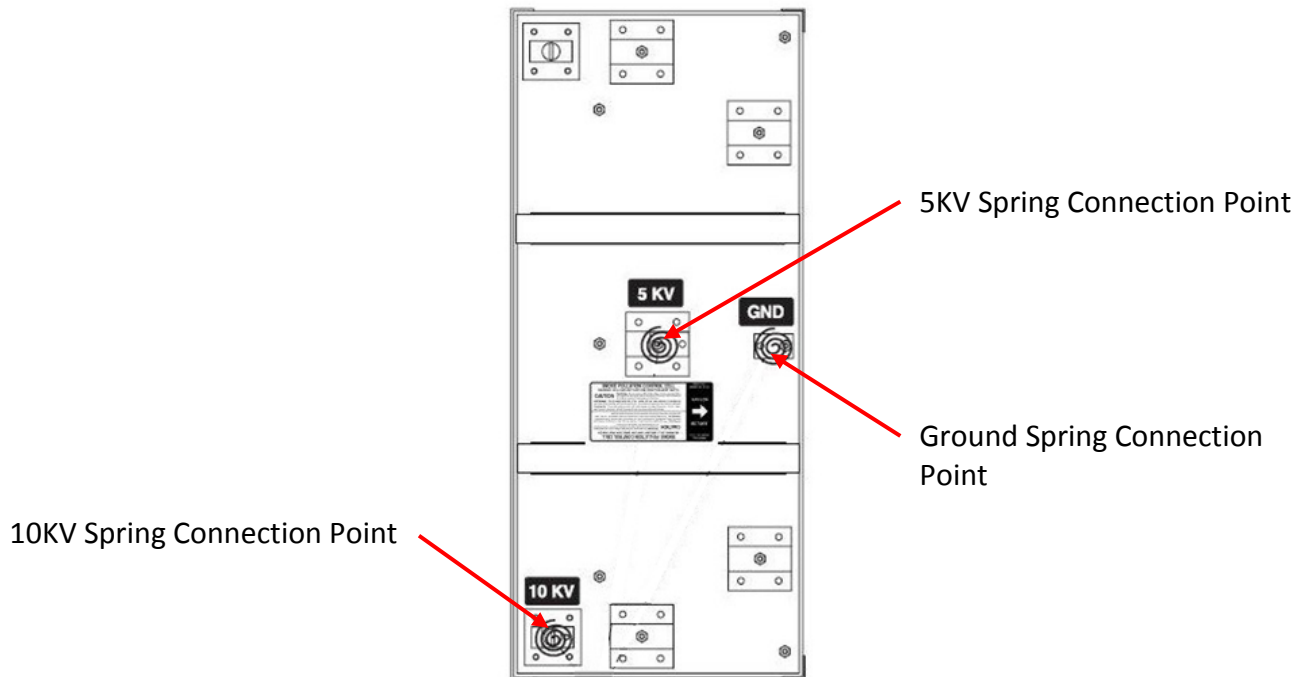

Figure 4-29-1
Inner Cell – End View

Shorting Cell Plates

There are three primary causes of an ESP Cell shorting. They are:

1. Foreign material lodged between Cell plates. If found remove.
2. Grease build up between Cell plates. If found clean thoroughly.
3. Cell plates warped or damaged reducing the distance between. Warped or damaged plates cannot be repaired. The Cell must be replaced.
4. Broken ionizing wire. Refer to "Replacing Ionizing Wires" on page 4-30.

Smoke Control – Troubleshooting (Cont.)

Replacing the Ionizing Wires

To replace an Ionizing Wire place the Cell on a work bench and proceed as follows:

1. Remove all of the broken wires from the Cell mounting brackets (Refer to Figure 4-30-1).
2. Install the new wire as follows:
 - a) Insert hook of one spring into the hole.
 - b) Use long-nose pliers and carefully pull second spring until hook can be secured in mounting bracket hole.

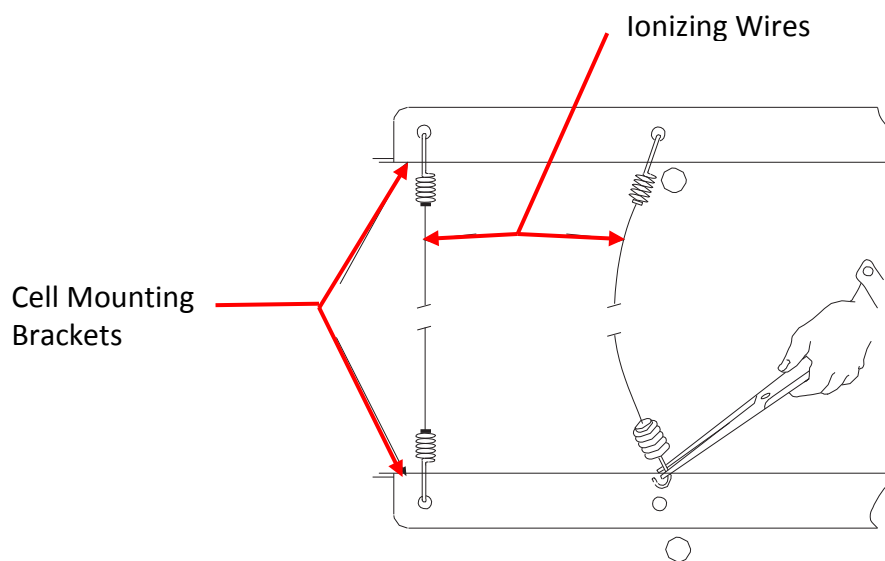

Figure 4-30-1
Replacing Ionizing Wires

Wash System – Troubleshooting

Using the Troubleshooting Charts

The following Troubleshooting Charts are designed to easily find common problems with the wash system, the probable cause and guidance on corrective action. In some cases the Corrective Action column will reference specific pages for additional guidance and corrective action.

Chart C-4-31-1

Troubleshooting the Wash System		
Symptom	Probable Cause	Corrective Action
1 The Wash Cycle is not adequately cleaning the Cells.	A. The water supply is turned off or partially off.	1 Check the hand valves inside the Main or Sub Wash Control Cabinet. Refer to Figure 4-41-1. 2 Check any valves upstream of the Wash Control Cabinet.
	B. Low Water Pressure - Check the water pressure gauge inside the Cell/Plumbing Compartment of the ClearAir Unit (Refer to Figure 4-39-1). The flow pressure should be 30 psi minimum to 50 psi maximum.	1 With the wash cycle on, try adjusting the water pressure regulator located at the inlet of the unit to achieve the desired pressure.
		2 Check the hand valves inside the Main or Sub Wash Control Cabinet to make sure they are fully opened. Refer to Figure 4-41-1.
		3 Check any valves upstream of the Wash Control Cabinet to make sure they are fully opened.
		4 The Line Strainer inside the Main or Sub Wash Control Cabinet may be clogged. Refer to page 4-48 for instructions on cleaning the Line Strainer.
	C. Low Water Temperature – Check the temperature gauge inside the Main or Sub Wash Control Cabinet while the wash cycle is on. The temperature should be between 140° F. to 180° F.	1 If below temperature it must be increased at the hot water source.
	D. Inadequate Wash Cycle frequency.	1 Refer to page 4-34 for guidance.
E. Inadequate length of Wash Cycle.	1 Refer to page 4-34 for guidance.	
F. Inadequate length of delay between Wash Cycles	1 Refer to page 4-34 for guidance.	

Wash System – Troubleshooting

Chart C-4-32-1

Troubleshooting the Wash System		
Symptom	Probable Cause	Corrective Action
1. The Wash Cycle is not adequately cleaning the Cells – Cont.	G. Detergent tank empty	1 Check and fill the detergent tank at least weekly.
	H. Improper detergent.	1 Refer to page 4-8 for recommended detergent.
	I. Detergent pump has lost its prime or is malfunctioning.	1 Refer to Page 4-41 for corrective action.
	J. Clogged Spray Nozzle(s).	1 Refer to Page 4-35 for instructions.
	K. Spray Nozzle leaking around manifold connection.	1 Refer to Page 4-35 and follow the instructions for a clogged spray nozzle.
	L. Ratio of Detergent to water is too low.	1 Change adjustment on Detergent Pump. Refer to Page 4-46 for instructions.
	M. Wash manifold is not oscillating properly.	1 Refer to Page 4-38 for corrective action.
2 Water spray nozzles do not come on when in a wash cycle.	A. Malfunctioning water solenoid valve.	1 Refer to Page 4-50 for instructions.
	B. Malfunction in the Gaylord Command Center or other Gaylord Stop and Start Controller.	1 Refer to the Technical Manual for the specific control for instructions
3 Spray nozzles are spraying when the system is <u>not</u> in a Wash Cycle.	A. Water Solenoid Valve is stuck in the open position.	1 Refer to page 4-50 for instructions.
4 Brass Swivel Elbow is leaking	A. "O" rings worn out.	1 Replace "O" rings. Refer to page 4-38 for instructions.

Wash System – Troubleshooting (Cont.)

Chart C-4-33-1

Troubleshooting the Wash System – Backflow Preventer		
Symptom	Probable Cause	Corrective Action
1 Intermittent discharge of water.	A. Intermittent discharge of water through the relief valve is fairly common and usually occurs if there is inlet pressure fluctuations of more than 3 psi and when the water solenoid valve closes to shut off the Wash Cycle	1 No action necessary.
2 Continuous discharge of water when the Ventilator is not in a Wash Cycle.	A. Foreign material in the check valve of the Backflow Preventer.	1 Refer to page 4-49. Leave the inlet hand valve open and close the outlet hand valve. If there is still continuous discharge it indicates that foreign material is preventing the check valve from closing. If repeated Wash Cycle flushing's will not clear the check valve then the unit must be repaired by a Certified Service Company. Refer to pages 4-49.

Wash System – Troubleshooting

Inadequate Washing of the ESP Cells

Inadequate washing of the ESP Cells may be caused by several conditions such as low hot water temperature, inadequate amount of hot water, low water pressure, type of detergent, ratio of detergent to water, frequency of the wash cycle, length of the wash cycle, length of the delay between wash cycles, clogged spray nozzles, and problems with the oscillating wash manifolds. Corrective actions for many of these items are covered in the Troubleshooting the Wash System Charts beginning on page 4-31. Items not covered in these charts are as follows:

1. Frequency of Wash Cycle

The wash system is designed to remove daily accumulations of smoke and grease particles in the ESP Cells. If the ClearAir Unit is not washed a minimum of once during a cooking day, a smoke and grease buildup could accumulate which the wash system cannot remove. If this occurs, the ESP Cells will no longer remove the smoke particles.

2. Length of Wash Cycle

The standard factory recommended wash time is 3 minutes. If the ESP Cells are not adequately cleaned it may be necessary to increase the length of the wash cycle. The wash cycle may be programmed for between 3-9 minutes. Refer to your specific Command Center Technical Manual for instructions on programming the wash time.

3. Length of Delay Between Wash Cycles

The delay time between the washes and rinses are programmed in the Command Center for a length of time to allow the building's hot water system to recover. The delay time may be programmed between 1 and 99 minutes. If the ESP Cells are not adequately cleaned cleaning may be improved by increasing the delay time between the wash cycles to allow the detergent to soak on the Cells longer. Refer to your specific Command Center Technical Manual for instructions on programming the delay time.

Important Note:

The wash, delay and rinse times may be programmed for different times as needed to adequately clean the ESP Cells. The Command Center illustrated in this manual may not represent the model of Command Center you have. Refer to the Technical Manual for your specific model of Command Center for complete instructions on programming wash, delay and rinse cycle times. If you do not have a Technical Manual for your Command Center, obtain the model number from the nameplate on your Command Center and contact Gaylord Industries. Refer to page 1-1 for contact information.

Wash System – Troubleshooting (Cont.)

4. Clogged Spray Nozzle

To check for a clogged spray nozzle proceed as follows:

Extreme Caution: Before removing the lead wires from Cells, a Standard Safety Voltage Test must be conducted as described on page 4-11. This test is necessary to insure that the Grounding Disc made proper contact with the brass grounding screws to drain all the residual power from the transformer.

- a) Open the Electrical and Cell/Plumbing access doors and remove all the Cells.
- b) Activate the wash cycle and observe to ensure all nozzles are spraying properly. If not, identify and make note of the clogged nozzles.

If nozzles are clogged they must be cleaned or replaced. The procedure for removing nozzles that spray the Outer Cells is different than removing nozzles for the Inner Cells as they can be easily reached by removing the Outer Cells. To replace Inner Cell nozzles the wash manifolds must be removed.

To remove Outer Cell nozzles proceed as follows:

1. Open the Electrical Compartment door first (the smaller door) and then the Cell/Plumbing Compartment door. Opening the Electrical Compartment door releases the Plunger Safety Switch, shutting off power to the transformer by releasing the micro switch, and draining residual power from the transformer(s) by the Grounding Disc making contact with the brass grounding screws (Refer to Figure 4-17-1 and 4-24-1).

Extreme Caution: Before removing the lead wires from Cells, a Standard Safety Voltage Test must be conducted as described on page 4-11. This test is necessary to insure that the Grounding Disc made proper contact with the brass grounding screws to drain all the residual power from the transformer.

2. Once the Standard Safety Voltage Test is conducted, remove the lead wires and remove all the Outer Cells.
3. Remove and replace nozzles as follow the procedure “Removing and Replacing Nozzle Procedure” on page 4-37.

To remove Inner Cell nozzles the wash manifolds must be removed. The top manifold, the manifold that goes through the Oscillating Motor is called the Motor Manifold and the remaining are called Standard Manifolds (Refer to Figure 4-36-1 and 4-36-2). To remove both types proceed as follows:

Removing the Motor Manifold.

1. Remove the linkage arm that connects all the manifolds together (Refer to Figure 4-36-1).
2. Place a pipe wrench on the manifold extension pipe and another on the square manifold and unscrew the manifold (Refer to Figure 4-36-1).
3. Push the manifold away from the extension pipe and then off to one side and slide out through the Cell/Plumbing Compartment access door.

Wash System – Troubleshooting (Cont.)

Clogged Spray Nozzle – Cont.

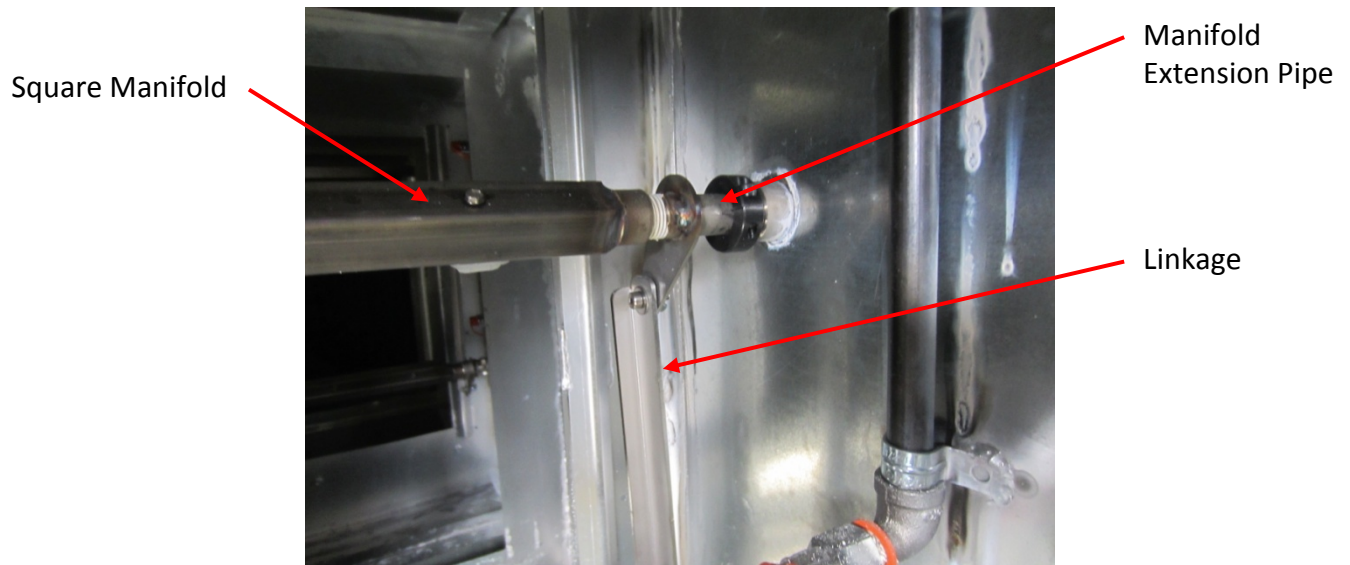

Figure 4-36-1
Motor Manifold

Removing a Standard Manifold.

1. The Standard Manifolds are connected to the water inlet pipe with a quick disconnect fitting. Slide the outer couple towards the water inlet and push the manifold away and off to one side (Refer to Figure 4-36-2).
2. Slide the manifold out through the Cell/Plumbing Compartment access door.

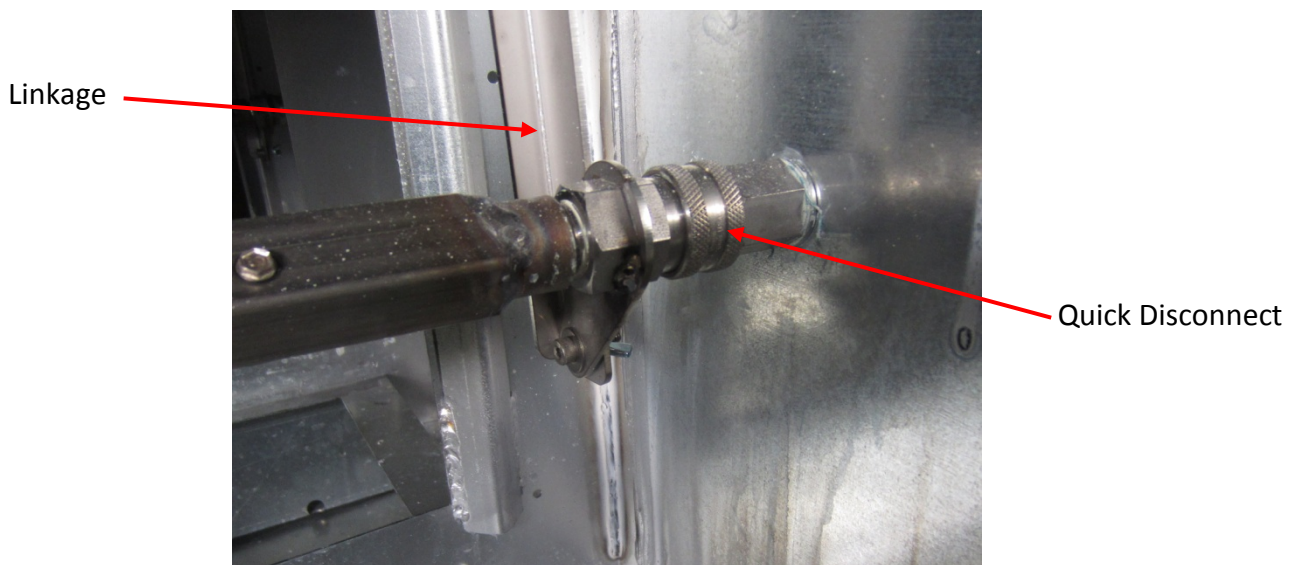

Figure 4-36-2
Standard Manifold

Wash System – Troubleshooting (Cont.)

Removing and Replacing Nozzles Procedure

Clogged nozzles may be cleaned by soaking in vinegar but it is recommended that they be replaced with a new one. Also, the gasket on the back side of the nozzle is not replaceable so if damaged the nozzle must be replaced. To remove and replace nozzles proceed as follows:

1. The nozzles are held in place by a 1/4" hex head screw, called a nozzle holding screw, on the back side of the manifold (Refer to Figure 4-37-1). Remove the screw and gently pry out the nozzle with a utility knife or a flat blade screwdriver. The nozzle has a small amount of silicone sealing it to the manifold.
2. Apply a very small amount of silicone to the shoulder and gasket area of the nozzle and slide into the hole (Refer to Figure 4-37-2).
3. Insert the hex screw and gently tighten to 7 inch lbs. max. **Caution: over tightening may strip out the hole in the nozzle. The nozzle has two offset receiving holes so if one strips, remove the nozzle, flip over and re-install.**



1/4" Hex Head Nozzle Holding Screw. Tighten to 7 inch lbs. max.

Figure 4-37-1
Nozzle Holding Screw

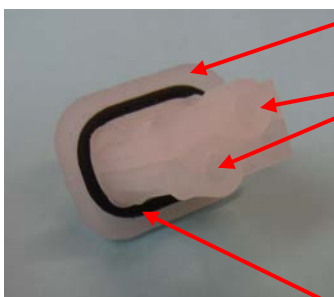

Shoulder

Hex Screw Receiving Holes

Gasket

Figure 4-37-2
Spray Nozzle Back Side

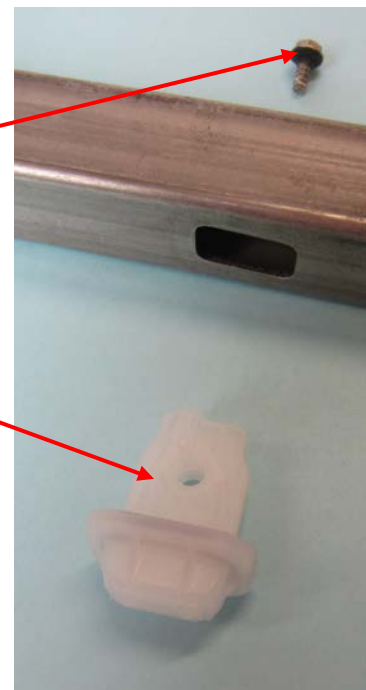

Nozzle

Figure 4-37-3
Manifold/Nozzle Exploded View

Wash System – Troubleshooting (Cont.)

5. Oscillating Wash

To check to see if the wash manifolds are oscillating proceed as follows:

- a) Open the Electrical and Cell/Plumbing Compartment access doors.
- b) Initiate a wash cycle and check to see if the motor drive is moving and that the clamp is holding the manifold so the manifold is moving back and forth (Refer to Figure 4-39-1).
- c) If the motor is not moving check the following:
 1. The motor electrically moves the shaft to the top position and springs to the bottom position via an internal spring. When the motor reaches the top position an end switch, located within the motor, opens, releasing relay contacts that provides power to the motor, allowing the motor to spring back to the bottom position. Referring to the wiring diagrams, electrically check the end switch and relay for proper operation.
- d) If it is determined that the motor is defective, remove and replace as follows:
 - 1) Shut off the electrical power using the Disconnect Switch on the Main Electrical Panel (Refer to Figure 4-23-1).
 - 2) Shut off the water to the unit.
 - 3) It may be necessary to remove the side panel on the Plumbing Compartment to accommodate a pipe wrench.
 - 4) Disconnect the water supply pipe at the union (Refer to Figure 4-39-1).
 - 5) Remove the “C” retainer ring from the brass swivel elbow (Refer to Figure 4-38-1).
 - 6) Slide the body of the swivel elbow along with the connected water supply pipe straight out.
 - 7) Disconnect the electrical connections and conduit at the motor.
 - 8) Loosen the shaft clamp around the manifold (Refer to Figure 4-38-1)
 - 9) Remove the screws holding the motor in place and slide the motor off.

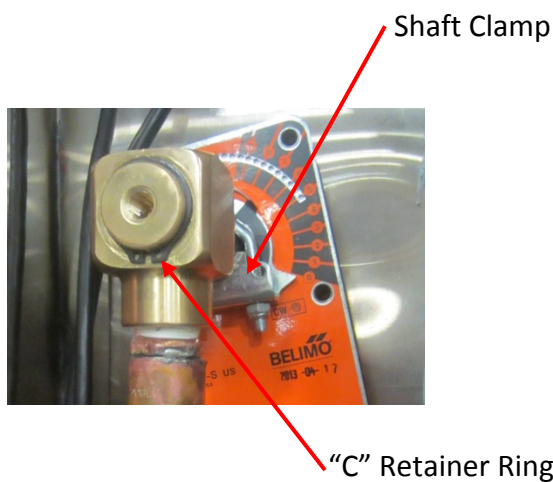

Figure 4-38-1
Brass Swivel Elbow
Assembled

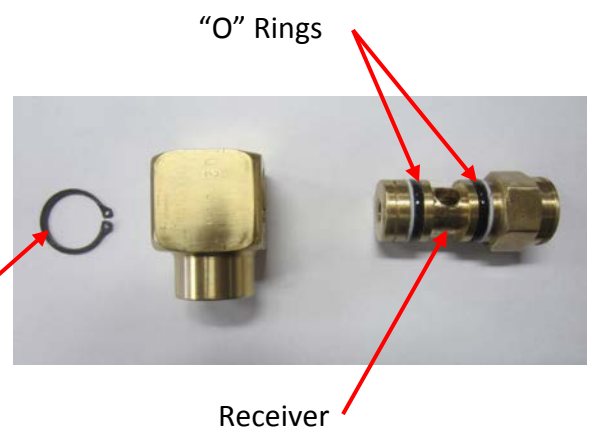

Figure 4-38-2
Brass Swivel Elbow
Disassembled

Wash System – Troubleshooting (Cont.)

Oscillating Wash - Cont.

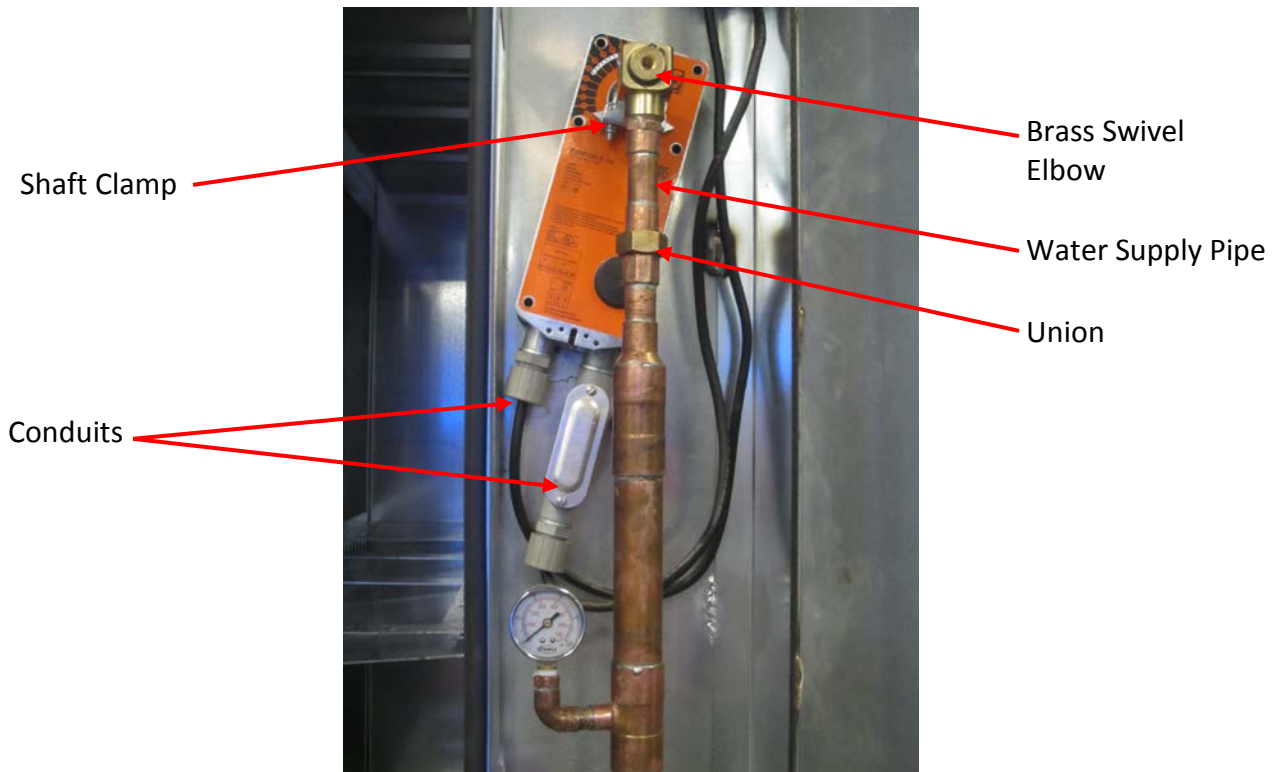

Figure 4-39-1
Plumbing Compartment
Upper Section

e) To replace the motor proceed as follows:

- 1) Slide the new motor over the manifold.
- 2) Replace and tighten the screws holding the motor in place.
- 3) Apply "O" ring lubricant around the receiver of the brass swivel elbow (Refer to Figure 4-38-2).
- 4) Slide the brass swivel elbow over the receiver end and install the "C" retainer ring (Refer to Figure 4-38-2).
- 5) Tighten the union.
- 6) Reconnect the electrical.

Extreme Caution: Before removing the lead wires from Cells, a Standard Safety Voltage Test must be conducted as described on page 4-11. This test is necessary to insure that the Grounding Disc made proper contact with the brass grounding screws to drain all the residual power from the transformer.

- 7) Remove the first ESP Cell that is nearest the motor so you can see the position of the manifolds.
- 8) By hand, turn the manifolds down to a 45° angle from horizontal. A small combination square may be useful for this procedure. Once positioned, tighten the shaft clamp to 40 ft. lbs.

Wash System – Troubleshooting (Cont.)

Oscillating Wash - Cont.

- 9) To check, initiate the wash cycle and observe the motor drive moving back and forth.

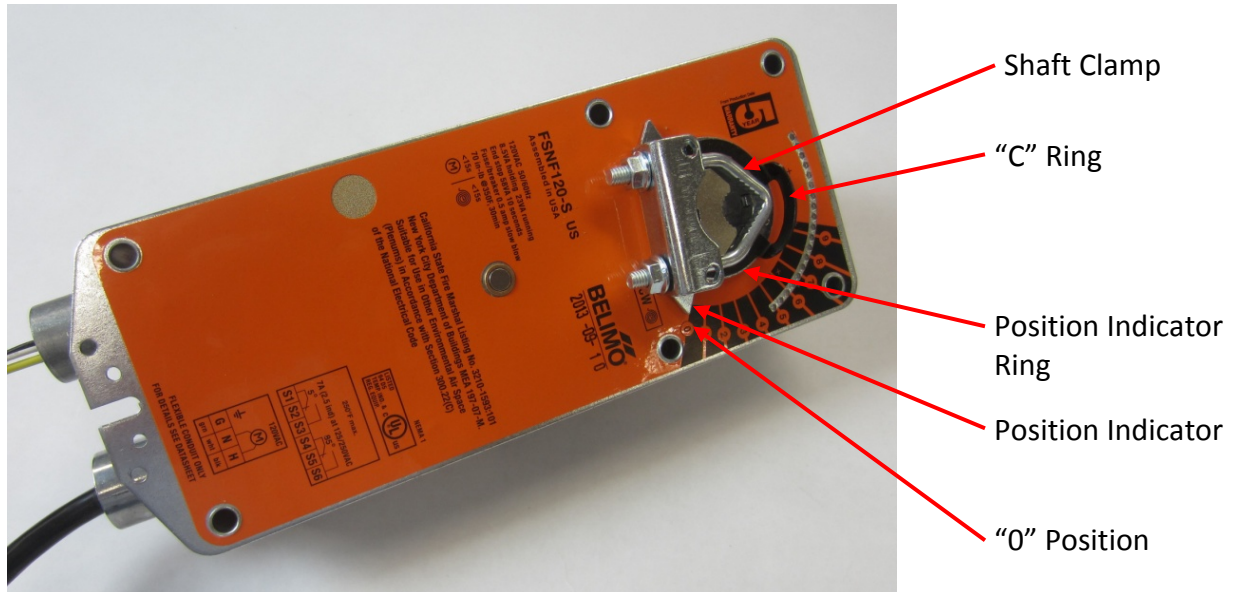

Figure 4-40-1
Oscillating Motor

6. Brass Swivel Elbow

If the brass swivel elbow is leaking water the "O" rings within the fitting are worn. To replace the "O" rings proceed as follows:

- a) Shut off the water to the unit.
- b) Disconnect the water supply pipe at the union (Refer to Figure 4-39-1).
- c) Remove the "C" retainer ring from the brass swivel elbow (Refer to Figure 4-38-1).
- d) Slide the body of the swivel elbow along with the connected water supply pipe straight out.
- e) Remove the two "O" rings (Refer to Figure 4-38-2)
- f) Apply "O" ring lubricant on the "O" ring and around the receiver of the brass swivel elbow.
- g) Slide on the new "O" rings.
- h) Slide the brass swivel elbow over the receiver end and install the "C" retainer ring.
- i) Tighten the union.
- j) Turn on the water and check for leaks.

Wash System – Troubleshooting (Cont.)

Wash Control Cabinet

Control Compartment. Appearance may vary depending upon Model Number of Control. There is not a Control Compartment on Sub Panels.



Detergent Pump

Detergent Flow Switch

Brass Check Valve

Temperature Pressure Gauge

Detergent Container

Outlet Hand Valve

Backflow Preventer

Air Gap

Line Strainer

Inlet Hand Valve

Figure 4-41-1
Typical Main Control Cabinet
(Sub Panel is the Same Except
Without Control Compartment

Detergent Pump

Overview

The detergent pump is an integral part of the proper operation of the ClearAir Wash Cycle. The pump is located within the Wash Down Control Cabinet (Refer to Fig. 4-41-1). When the Wash Cycle begins, the pump is energized and draws detergent up from the detergent container, pushing it through the copper tubing, flow switch, brass check valve and into the hot water line.

Initial Operation

To prime and operate the pump for the first time, it is recommended that water be used instead of detergent to prevent detergent from spilling in case of leaks at the system's fittings.

The pump is operating properly when both upper and lower poppet checks in the pump head can be seen moving up and down slightly.

Wash System – Troubleshooting (Cont.)

Detergent Pump – Initial Operation (Cont.)

If the pump does not self-prime, an air lock may have developed within the pump head and the following action should be taken:

1. Hold down the Pump Test Switch, located on the bottom of the electrical junction box on the pump (Refer to Figure 4-37-1).
2. Loosen the Top Cap slightly to allow air to be pushed out and then retighten. Repeat as necessary until liquid climbs up the tube and fills Pump Head and both Poppet Checks are moving up and down slightly. Note: Be careful not to tighten to much as it will cut the “O” ring.
3. Check all fittings to ensure an airtight system.

If the pump still does not work properly, check and rebuild or replace the Foot Valve, Pump Head, and/or Brass Check Valve in the following order:



Figure 4-42-1
Detergent Pump

1. Foot Valve (Refer to Figure 4-43-1 and Figure 4-43-2)
 - a) The Foot Valve should be clean and immersed in the detergent.
 - b) To clean the Foot Valve proceed as follows:
 - 1) Remove Tubing and Foot Valve from the Detergent Reservoir.
 - 2) Slide the stainless steel tube away from the Foot Valve.
 - 3) Pull the vinyl tubing off the Foot Valve.
 - 4) Unscrew the Screen from the Valve Base.
 - 5) Remove the Ball Check and the “O” Ring from the Screen.
 - 6) Clean the entire assembly and reassemble.

Wash System – Troubleshooting (Cont.)

Detergent Pump – Cont.

- 7) Replace Foot Valve and test.
- 8) If the Foot Valve does not operate properly after cleaning replace with a new one.



Figure 4-43-1
Foot Valve

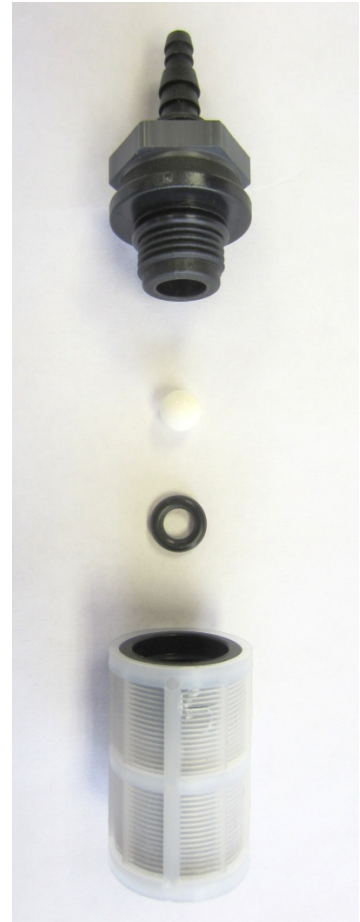

Figure 4-43-2
Foot Valve
Exploded View

2. Pump Head (Refer to Figure 4-41-1 and Figure 4-42-1)

a) Remove, check and the clean the Pump Head as follows:

- 1) Disconnect the vinyl tubing coming into the bottom of the head.
- 2) Disconnect the copper tubing coming out the right top of the head
- 3) Remove the four mounting screws (Figure 4-45-1, Pc. 5) and remove the head from the Pump Head Base.

Wash System – Troubleshooting (Cont.)

Detergent Pump – Cont.

- 4) Remove the Top Cap (Figure 4-45-1, Pc. 21) and then remove the Spring (Figure 4-45-1, Pc 11) and the Poppet Check (Figure 4-45-1, Pc. 12). Repeat this procedure for the Bottom Adaptor (Figure 4-45-1, Pc.10)
 - 5) Inspect the Pump Head for cracks and replace with a complete new Pump Head if necessary.
 - 6) If the Pump Head is not cracked, insert new Poppet Checks and reassemble.
 - 7) Before remounting the Pump Head, inspect the Diaphragm (Figure 4-45-1, Pc. 18) for cracks or holes. Replace if necessary. To remove the Diaphragm unscrew counter clockwise.
 - 8) Mount Pump head to Pump Bracket.
 - 9) Reattach the vinyl and copper tubing.
 - 10) If the Pump Head does not operate properly after cleaning, replace with a Pump Head Kit (Refer to page 7-8 for parts).
3. Brass Check Valve (Refer to Figure 4-41-1 and Figure 4-45-1, Pc. 15).
- a) Remove, check and clean Brass Check Valve as follows:
 - 1) Turn off water at the Outlet Hand Valve that is part of the Backflow Preventer (Refer to Figure 4-41-1).
 - 2) Disconnect the copper tubing coming from the Detergent Flow Switch
 - 3) Remove the entire Brass Check Valve from the tee. **Caution:** Have a container ready to catch the water that will come out the pipe tee when the valve is removed.
 - 4) Inspect the valve for deterioration and small holes and replace, if necessary, with a new Brass Check Valve.
 - 5) To clean the Check Valve separate the two half's of the body.
 - 6) Remove the Poppet Check and clean the valve body.
 - 7) Reassemble the check valve and reinstall in the tee.
 - 8) Reattach the copper tubing.
 - 9) If the Brass Check Valve does not operate properly after cleaning, replace with new one.

Wash System – Troubleshooting (Cont.)

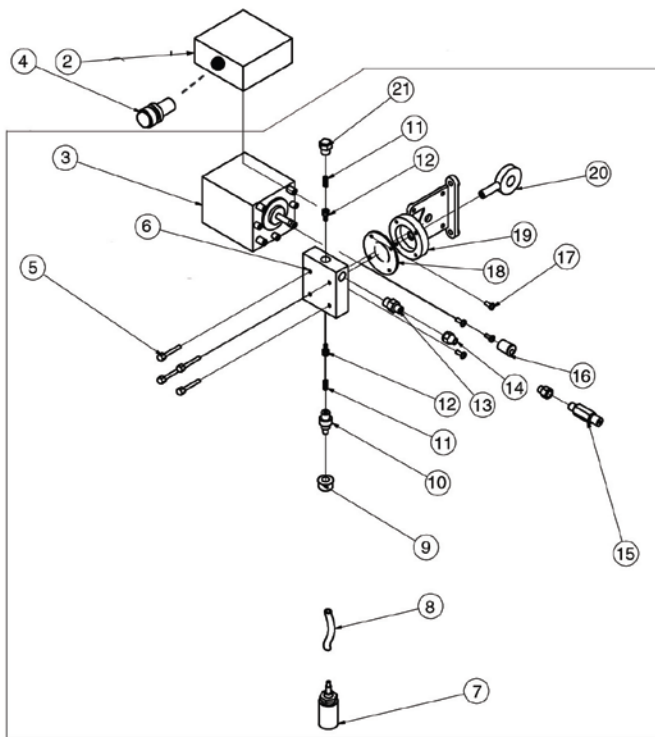

Figure 4-45-1
Detergent Pump
Exploded View

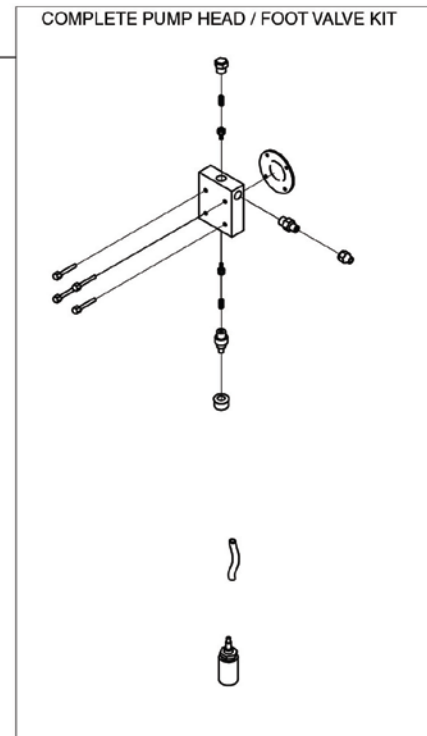

Figure 4-45-2
Pump Head
Exploded View

Detergent Pump Motor

If it is determined that the pump motor is burned out the entire Detergent Pump must be replaced. To remove the pump, proceed as follows:

1. Shut off power to the Wash Control Cabinet pump junction box.
2. Disconnect the electrical conduit and wiring from the pump junction box.
3. Disconnect the vinyl tubing coming up from the Detergent Tank.
4. Disconnect the copper tubing coming out the right top of the pump head.
5. Remove the two nuts at the pump mounting bracket and remove the pump.
6. Mount new pump.
7. Reconnect the vinyl and copper tubing line.
8. Reconnect the wiring and conduit.
9. Turn on power.
10. Test the pump.

Wash System – Troubleshooting (Cont.)

Detergent Pump – Cont.

Detergent Flow Ratio

The Detergent to water ratio is determined by the setting on the Adjustable Cam located on the end of the motor shaft (Refer to Figure 4-46-1). The Adjustable Cam may be adjusted from “0” to “6” with “0” being no detergent pumping, “1” the lowest ratio of Detergent to water and “6” the highest ratio. The pump comes from the factory set at either number “1”, “1.5” or the “2” position depending upon the total length of Ventilator, in feet, the pump is serving. Refer to Chart C-4-47-1 for detergent consumption and factory settings. Generally, the factory setting will be correct to provide efficient cleaning of the ESP Cells, however, adequate cleaning is dependent upon a number of factors:

1. Actual amount on cooking within the hours of fan operation.
2. Type of food product being cooked.
3. Water pressure. Required minimum pressure is 30 psi at the ClearAir Unit pressure gauge.
4. Water temperature. Required temperature is 140°F. Min. to 180°F. Max.
5. Length of Wash Cycle
6. Frequency of Wash Cycle
7. Delay between wash and rinse
8. Type of detergent. Refer to page 4-8 for recommended detergent.
9. Ratio of detergent to water.

If it is determined that more detergent is being used than necessary, or that a higher ratio of detergent to water is required, the ratio may change by re-setting the Adjustable Cam to a lower or higher position. To change the cam setting, proceed as follows (Refer to Fig. 4-46-1):

1. Remove the plastic Protective Cover (not shown), that covers the Adjustable Cam Assembly, by removing the cover screw.
2. Loosen the Wing Nut approximately 1/8”.
3. Turn the Adjuster Ring until the Pointer lines up with the desired number, or a point between the numbers.
4. While holding the Adjuster Ring tighten the Wing Nut.

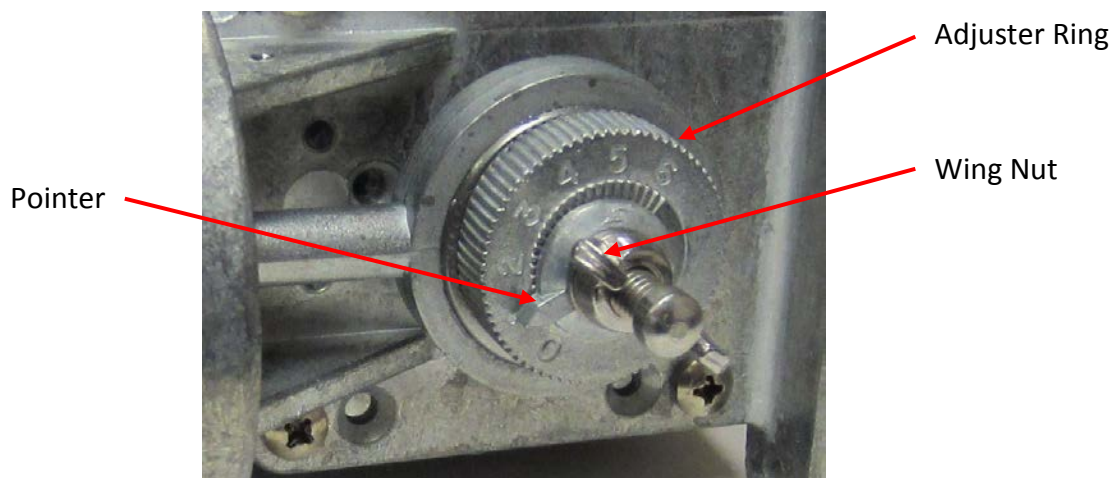

Figure 4-46-1
Adjustable Cam Assembly

Wash System – Troubleshooting (Cont.)

Detergent Pump – Cont.

The following Detergent Consumption Chart shows the approximate amount of detergent used with different Cam Settings with the pump pumping against a water pressure of 30 psi.

Chart C-4-47-1

Detergent Consumption Chart							
Cam Setting	Oz. Per Minute at 40 PSI Water Pressure	Length of Wash Cycle					
		3 Minutes		5 Minutes		9 Minutes	
		Oz. Per Day	Gal. Per Month	Oz. Per Day	Gal. Per Month	Oz. Per Day	Gal. Per Month
0	0	0	0	0	0	0	0
1	0.85	2.6	0.6	5.1	1.2	7.7	1.8
1.5	2.13	6.4	1.5	12.8	3.0	19.2	4.5
2	3.27	9.8	2.3	16.4	3.8	29.4	6.9
3	5.76	17.3	4.1	28.8	6.8	51.9	12.2
4	7.25	21.8	5.1	36.3	8.5	65.3	15.3
5	8.32	25.0	5.9	41.2	9.6	74.9	17.6
6	8.74	26.2	6.1	43.7	10.2	78.7	18.4

Important Note: Changing the Cam Setting to a higher level from the factor setting should only be done after all other measures such as increasing the length of the Wash Cycle and or Frequency, and increasing the temperature of the water have been made as the detergent is the largest cost of operating the Wash System.

Detergent Flow Switch

The Detergent Flow Switch (Refer to Figure 4-47-1) is a sealed unit and cannot be repaired. If determined that the Flow Switch is faulty replace as follows:

1. Turn off power to the Command Center.
2. Disconnect the wiring from the pump junction box.
3. Disconnect the copper tubing on both sides of the switch.
4. Install a new Flow Switch.



Figure 4-47-1
Detergent Flow Switch

Wash System – Troubleshooting (Cont.)

Line Strainer

The Line Strainer (Refer to Figure 4-48-1 and 4-48-2) prevents foreign material from going downstream and causing the Reduced Pressure Principle Device, Solenoid Valves and the ClearAir water spray nozzles to malfunction. If it is determined that foreign material is flowing downstream of the Line Strainer, the strainer screen must be removed and cleaned. To clean proceed as follows:

1. Turn off the hot water supply upstream of the Line strainer.
2. Using a wrench, slowly unscrew the Screen Plug. **Caution:** The water may still be under pressure causing the Screen Plug to blow off and water to discharge rapidly.
3. Remove the Screen.
4. Using a wire brush and hot detergent water, clean the screen.
5. Replace the Screen, Screen Plug and tighten thoroughly.
6. Test for leaks.



Figure 4-48-1
Line Strainer



Figure 4-48-2
**Line Strainer With
Screen Removed**

Backflow Preventer (Reduced Pressure Principle Device)

Overview

A Backflow Preventer is mounted within the Wash Control Cabinet and is required by code to prevent contaminated water (water with detergent) from back-flowing upstream to potable water (Refer to Figure 4-41-1, and 4-49-1). The Backflow Preventer is manufactured by the Watts Regulator Company.

The Backflow Preventer consists of two Check Module Assemblies with spring loaded check valves and one Relief Valve Assembly with a spring loaded relief valve. There is a shut off valve on the inlet and outlet sides of the unit to allow servicing. This device prevents backflow by opening and closing the check valves if the pressure from the inlet side to the outlet side of the device varies.

Wash System – Troubleshooting (Cont.)

Backflow Preventer – Cont.

Initial Start-Up

To avoid water hammer or shock damage, perform the following initial start-up procedures:

1. Close the Outlet Hand Valve.
2. Open the Inlet Hand Valve slowly, fill the valve and bleed the air through test cock number 2, 3, and 4.
3. When the valve is filled, open the Outlet Hand Valve slowly and fill the remaining water supply system.
The initial start-up procedure is now complete.

Intermittent Discharge

Intermittent discharge of water through the relief valve is fairly common and usually occurs if there are inlet pressure fluctuations of more than 3 psi and when a solenoid valve closes after a Wash Cycle.

Continuous Discharge

If there is continuous discharge or rapid spitting of water out the relief valve when the Ventilator is not in a Wash Cycle, contact the Watts Regulator Company for service.

Caution: In no case should the relief valve outlet port be plugged, closed off or restricted.

Note: Local jurisdictions typically require annual inspections and testing by a company certified and licensed to perform such duties. For the name of your nearest certified company, call Watts Regulator, 815 Chestnut St., North Andover, MA 01845. Phone 978-689-6066.

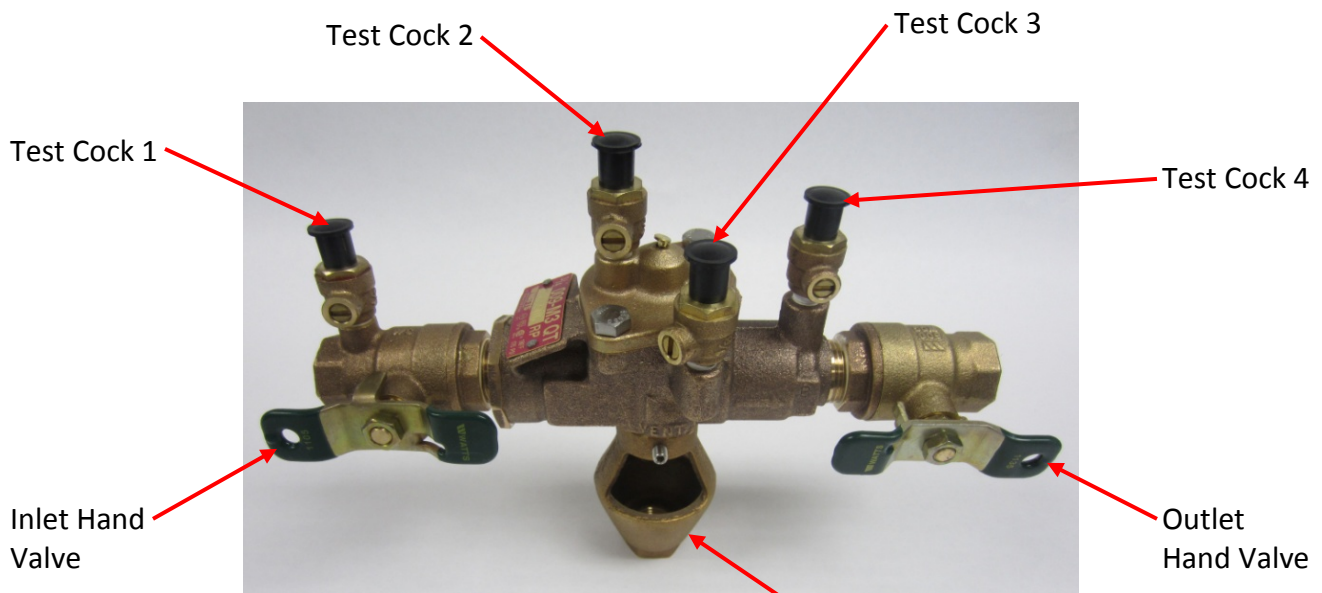

Figure 4-49-1
Backflow Preventer

Air Gap Assembly
(water discharge point)

Wash System – Troubleshooting (Cont.)

Water Solenoid Valve

Overview

Depending upon the number of ESP Cells, one or more water Solenoid Valves is located at the bottom of the Plumbing Compartment (Refer to Figure 4-50-1). The Solenoid Valve(s) is controlled by the Command Center.

Figure 4-50-1
Water Solenoid Valve



Water Solenoid
Valve

Sticking Solenoid Valve

If water is running when the Command Center is not in a Wash Cycle it indicates that the Water Solenoid Valve is stuck in the open position. If this is the case, perform the following: (Refer to Figure 4-51-1)

1. Gently tap the valve housing with a hammer. This should release foreign material trapped in the valve and the water should stop.
2. If tapping does not release the foreign material the valve must be disassembled and checked. To disassemble the valve proceed as follows: (Refer to Figure 4-51-1)

Danger: Always shut off electrical power when repairing electrical controls. Contact with unsecured power will result in immediate injury or death to personnel.

- a) Shut off electric power to the Wash Control Cabinet.
- b) Pry up the cap on the top of the Solenoid and slide the Solenoid Coil off the coil stem.
- c) Remove the four bolts to separate the valve casing.
- d) Remove the valve diaphragm, inspect and clean. Clean both half's of the valve casing.
- e) Reassemble in reverse order.
- f) If the diaphragm looks worn or defective it should be replaced with a Solenoid Valve Repair Kit (Refer to page 7-2-1).

Wash System – Troubleshooting (Cont.)

Water Solenoid Valve (Cont.)

If solenoid valve sticking is a recurring problem, it indicates that foreign material in the water supply line is escaping through the line strainer located in the Wash Control Cabinet. The screen in the line strainer should be removed, checked for holes, and cleaned. For instruction, refer to Page 4-48.

Solenoid Valve Not Opening

If a Solenoid Valve does not open when the system is placed into a Wash Cycle perform the following:

1. Check to see if there is electrical power at the solenoid coil. If there is no power refer to the specific Technical Manual for your Command Center, the Troubleshooting Section.
2. If there is power it indicates that the Solenoid is burned out. To replace the Solenoid proceed as follows:

Danger: Always shut off electrical power when repairing electrical controls. Contact with unsecured power will result in immediate injury or death to personnel.

- a) Shut off electric power to the Wash Control Cabinet.
- b) Open the junction box next to the Solenoid Valve and disconnect the valve wires.
- c) Lift up the tab on the Solenoid Retainer and slide the retainer off (Refer to Figure 4-51-1)
- d) Slide the Solenoid Coil off the coil stem.
- e) Pull the wires out of the conduit going to the junction box.
- f) Slide the wires from the new Solenoid through the conduit and into the junction box and connect the wires.
- g) Slide the new Solenoid onto the coil stem.
- h) Install the Solenoid Retainer.

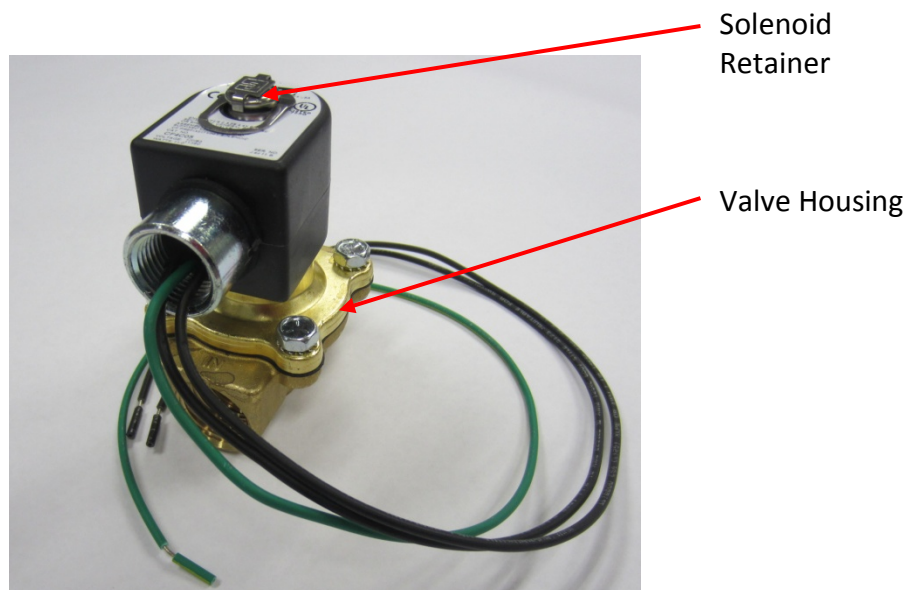
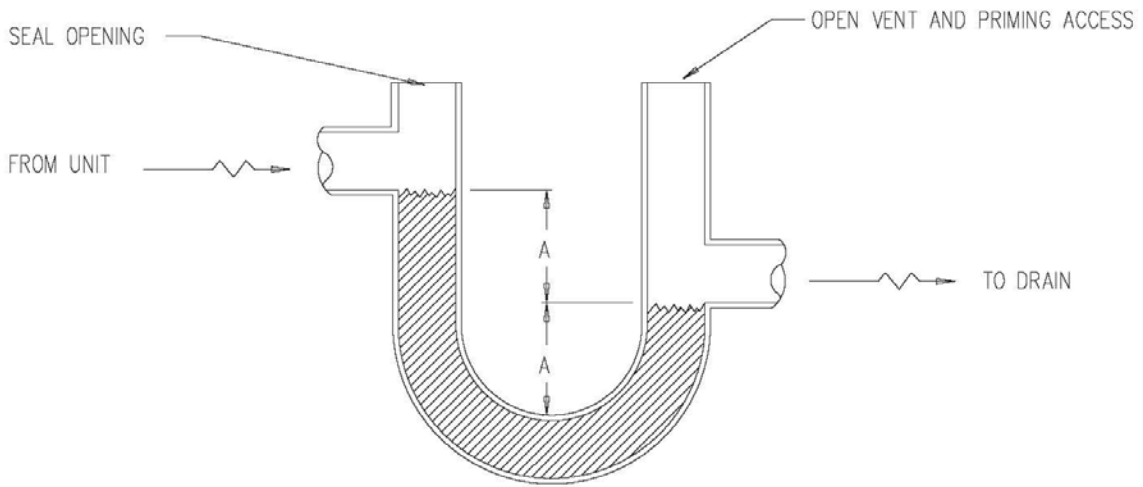

Figure 4-51-1
Water Solenoid Valve

RSPC-ESP Drain

A (MINIMUM) = MAXIMUM EXPECTED PRESSURE IN INCHES WATER GAUGE PLUS 1"



RECOMMENDED TRAP LOCATED ON NEGATIVE SIDE OF FAN

Odor Control

Overview

ClearAir Units are available with two types of odor control, a media bed type or a spray odor control. There are two types of media beds, one is called the Loose Fill type and the other is called the Media Panel type. The odor control media utilizes a blend of 50% potassium permanganate and 50% activated carbon. The media is housed in either Odor Control Modules as shown in Figure 5-5-1 or compressed in Media Panels as shown in Figure 5-4-1. As the air is drawn through the media the potassium permanganate oxidizes the lighter odor molecules and chemically changes them into harmless solids which remain in the media, and the carbon absorbs the heavier odor molecules.

ClearAir Units that include media bed odor control have a suffix in the model number of “SO” for single pass, “DO” suffix for double pass and “TO” for triple pass odor control. ClearAir that utilize spray odor control have a suffix SPO in the model number. Refer to the Nameplate on the unit (Refer Appendix D page D-1 for a sample Nameplate).

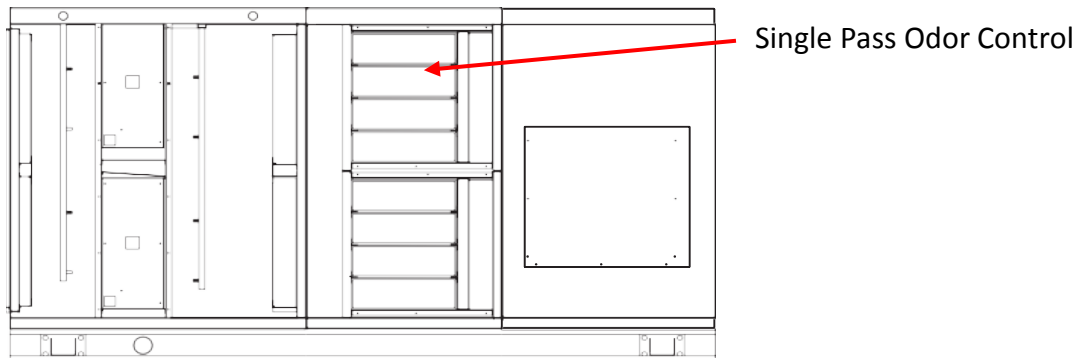

Figure 5-1-1
Typical ClearAir Unit
With Single Pass Odor Control

The life of the odor control media is dependent upon several factors such as the type of odor, amount of odor molecules, grease loading and the exhaust air temperature. The potassium permanganate media has a flat efficiency curve, meaning that the efficiency, or effectiveness, stays constant until the media has expended and then the efficiency drops off rapidly. The carbon portion of the media’s efficiency drops continually during its life. Thus a regular schedule of change out of odor control media needs to be established and followed.

Media Panel Type Odor Control

With the Media Panel type the odor control, the media is compressed into 18” x 24” x 1.25” Media Panels which slide into a Module (Refer Figure5-4-1). The Modules then slide into the ClearAir racks. As an option the unit may be equipped with a 30% pleated media After Filter located immediately downstream of the Media Models.

Loose Fill Type Odor Control

The Loose Fill type the odor control media is housed in steel reusable Media Modules that can be replenished with Loose Fill media (refer to Figure 5-5-1). With Loose Fill media a 30% pleated media After Filter located immediately downstream of the Media Models is required.

Odor Control - Maintenance

Maintenance – Media Panel Type

Generally the life of the Odor Control Media is the number of days shown in Table T-5-2-1. However every cooking condition varies and therefore it is important to establish the frequency of inspection and replacement of the media. If the unit has Double or Triple Pass Odor Control the life expectancy between the first, second and third pass will vary. To assist in determining if the media has expended an Odor Control Media Monitoring Tube is provided (see Figure 5-2-1). This tube is mounted in the odor control plenum of the ClearAir Unit so that it is exposed to the odor molecules in the exhaust air, the same as the Media Modules. The tube is identified by the label shown in Figure 5-2-2. The label includes an area where the date of the last inspection and Media Panel installation can be filled in with a grease pencil.

Table T-5-2-1

Odor Control Media Bed Inspection Frequency Table	
Type of Cooking Equipment	Frequency in Days
<u>Light Duty</u> - Ovens, steamers, and kettles.	120
<u>Medium Duty</u> – Braising pans, tilting skillets, fryers, griddles, grooved griddles, open burner ranges, hot top ranges, and conveyor ovens.	90
<u>Heavy Duty</u> – Gas and electric charbroilers, upright broilers, woks and conveyor broilers.	60
<u>Extra Heavy Duty</u> – Solid fuel broilers.	30



Figure 5-2-1
Odor Control Media
Monitoring Tube

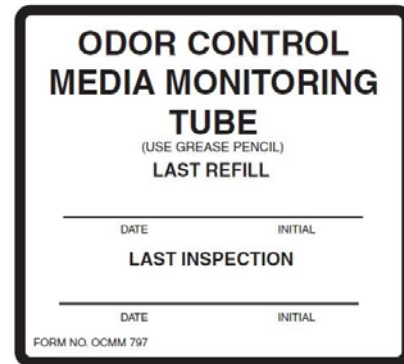

Figure 5-2-2
Monitoring Tube Label

To inspect the Media Monitoring Tube, using an open end wrench, turn the tube nut counter clockwise and remove the Monitoring Tube assembly. The Media starts off a dark purple so if the media in the Monitoring Tube is Dark Purple it is still good. If the Media is dark brown, break a granule open and if the inside is light tan there is very little life left and the Media should be replaced. If the outside of the granules are light tan the Media is completely expended and the Media must be replaced.

Odor Control – Maintenance (Cont.)

If you are unable to determine the status of the Media send a small sample, one teaspoon, to Green Ladder Technologies. Note the date of installation on the sample. They will conduct a life test and advise the results by e-mail, fax or phone. Refer to page 5-4 for contact information. Once the media in the Monitoring Tube has expended, and you wish to continue checking with the Media Monitoring Tube it must be replaced with a new one. To order new Media Monitor Tube contact Gaylord Industries.

Replacing Media Panels

Caution: Each Module weighs approximately 28 lbs. and may be awkward to handle, particularly from the upper racks. It is highly recommend that a heavy duty steel wheeled ladder be used when removing the upper modules.

Caution: Exhaust Fan must be off before opening the Odor Control Media Access Door

To replace the Media Panels proceed as follows:

1. Turn off the exhaust fan.
2. Open the Odor Media Access Door.
3. Carefully slide out the Modules.
4. Place the Module on edge with the open side up, “V” side down (refer to Figure 5-3-1).
5. Flip the Locking Clip up (refer to Figure 5-3-1).
6. Pull out both Media Panels (refer to Figure 5-3-2)
7. Slide in the new Media Panels making sure the label stating “Inlet Side” is facing out. The two stiffening rods on the back of the panel should be facing the inside of the “V”.
8. Flip the Locking Clip down.
9. Carefully slide the Modules, with the label facing you, back into the Racks making sure the “V” of the Module is facing the airflow as shown in Figure 5-5-3.
10. Replace the Odor Media Access Door.
11. Dispose the used Media Panels. The used panels are not recyclable

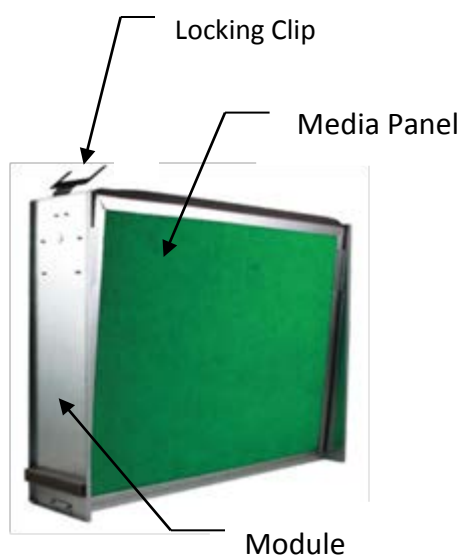

Figure 5-3-1
Module with Both
Media Panels in
Place



Figure 5-3-2
Lifting Out One
Media Panel



Figure 5-3-3
Module with One
Media Panel
Removed

Odor Control – Maintenance (Cont.)

Ordering New Media Panels

The Media Panels slide into Modules, and there are two Media Panels per Module (Refer to Figure 5-3-2).

To order new Media Panels contact Green Ladder Technologies.

Green Ladder Technologies, LLC
1502 Louis Bork Drive
Batavia, IL 60510
E-mail: info@greenladdertech.com
Phone: 630-457-1872

Replacing Loose Fill Media

There are two methods of replacing the media, the “Advancing Program” or “Site Refill”.

Advancing Program - This is a program offered by Cameron Great Lakes, Inc. where they will ship recycled pre-filled Modules in exchange for used Modules. The pre-filled Modules are shipped two to a box, box size 25" x 25" x 13", which weigh approximately 90 lbs. The boxes are palletized, 36 to a pallet, and are shrink wrapped. Three primary advantages of the Advancing Program are: 1) virtually no requirement for storage except for the short period of time needed to switch the new modules for the expended ones, 2) minimizes unit down time, and 3) avoids filling on site.

To participate in this program contact:

Cameron Great Lakes
2335 NW 29th
Portland, OR 97210
800-777-4044
630-377-0711

To participate in the “Advancing Program” proceed as follows:

1. Contact the local Cameron/Great Lakes distributor and order the number of Modules required.
2. Upon receipt, remove the depleted Modules and replace with the new Modules.
3. Empty the media from the depleted Modules into containers for disposal.
4. Pack the empty used Modules into the boxes the new ones came in and ship back to the distributor.

Site Refill - Site refill involves the purchase and storage of new media, emptying and refilling the modules and disposing of the spent media. New media may be purchased from your local Cameron Great Lakes distributor. For the name and phone number of the local distributor, call Cameron/Great Lakes.

New media comes in standard five gallon buckets which weigh 40 lbs each. One bucket will refill approximately 1.33 modules. It is recommended that new media is purchased no more than 2 weeks in advance of its use. The buckets should be protected against physical damage as KOR48/carbon will begin to oxidize any odor molecule when exposed to atmosphere. The buckets should be stored in a cool dry area.

Removing and Refilling the Modules

Caution - Each Module weighs approximately 30 lbs. and may be awkward to handle particularly in the upper racks. It is highly recommended that a heavy duty steel wheeled ladder be used when removing the upper Modules.

Odor Control – Maintenance (Cont.)

Caution - Exhaust fan must be off before opening the odor control media access door.

Refilling the Modules is a relatively simple task not requiring any special tools. Follow steps 1-15:

1. Turn off exhaust fan.
2. Open Media Access Door.
3. Carefully slide out the Modules.
4. Set the Module on end so the securing screw is on top.
5. Remove the securing screw and slide the cover plate off (Refer to Figure 5-5-1).
6. Empty the old media into a container for disposal.
7. Place the filling jig over opening.
8. Pour the media into the Module.
9. To eliminate voids, shake or vibrate the Module to ensure that the media settles.
10. Continue adding media until Module is full.
11. Caution: Do not overfill as it may cause the sides to bulge.
12. Replace cover plate and install securing screw.
13. Optional - some dusting may occur on initial startup of the unit. To minimize this, vacuum or blow out the Modules (Refer to Figure 5-5-2).
14. Slide the Modules back into the rack being cautious that the airflow label is matching the airflow of the unit (Refer to Figure 5-5-3).
15. Replace the Odor Media Access Door.

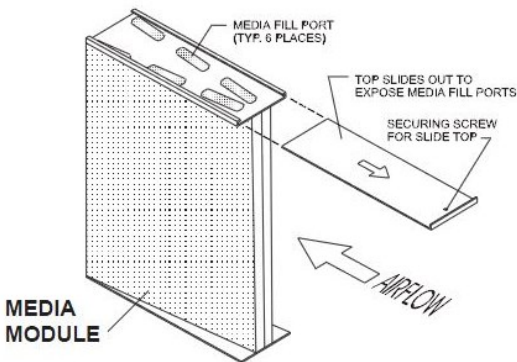

Figure 5-5-1

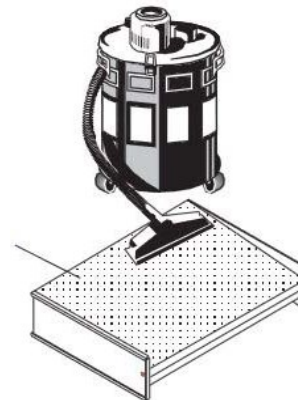

Figure 5-5-2

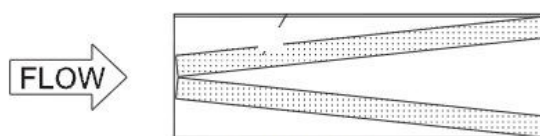
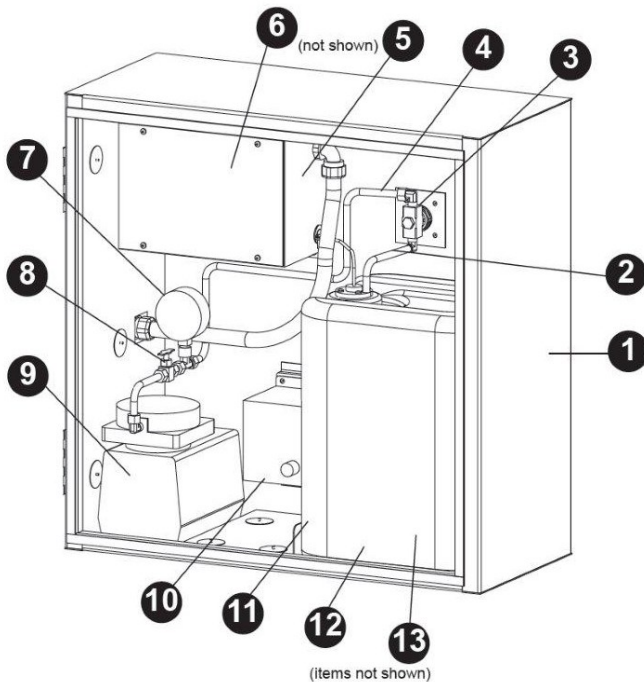

Figure 5-5-3

Spray Odor Control

Overview

The Spray Odor Control system is housed in a cabinet mounted on the ClearAir Unit (refer to Figure 5-6-1). The major components are a spray nozzle, air compressor, timers and a 5 gallon tank to hold the Spray Odor solution. The compressor pulls the solution up through the pick-up tube in the tank by creating a vacuum, and then pushes it out through an atomizing nozzle into the plenum after the Final Filters. The spray is not on constant, but is timed on and off, the length of time on dependent upon the amount of odor created by the cooking process. There are two (2) timers, one (1) for the “Cycle Timer” (this is the spray “OFF” timer) and one (1) for the “Spray Timer” (this is the spray “ON” timer) (Refer to Figures 5-7-1 and 5-7-2). Both timers are calibrated and can be set between 5 and 600 seconds. The factory setting is always 15 seconds “ON” and 15 seconds “OFF”.



Legend	
1	Spray Odor Control Cabinet
2	1/4" I.D. Flexible Suction Tube
3	Spray Nozzle Assembly
4	3/8" Copper Tubing
5	Electrical Box
6	Cycle and Spray Timer Relay
7	Pressure Gauge
8	Needle Valve
9	Air Compressor
10	Heater
11	5 Gallon (18.9 Liter) Container of GS-750
12	Spray Chemical Level Sensor (In Tank)
13	1/4" Foot Valve (In Tank)

Figure 5-6-1
Spray Odor Control Cabinet
With Door Removed

Spray Odor Control

Setting the Timers

CAUTION: Always de-energize the ClearAir Unit before opening the Electrical and Timer Control Panel inside the Odor Spray Cabinet.

The Spray Odor Control unit operates on spray-on and spray-off timed cycles while the ClearAir Unit is in the “Fan On” mode. To adjust the Cycle Timer and Spray Timer, open the Spray Odor Cabinet, and remove the screwed-in-place timer control cover plate. Adjust as necessary for satisfactory odor control as follows:

Cycle Timer

To set the “Off” period, turn the dial to the desired off time interval.

Spray Timer

To set the “On” period, turn the dial to the desired on time interval.

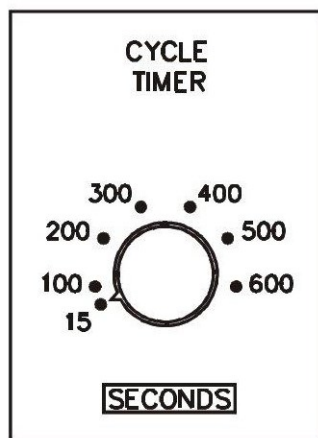

Figure 5-7-1
Cycle Timer

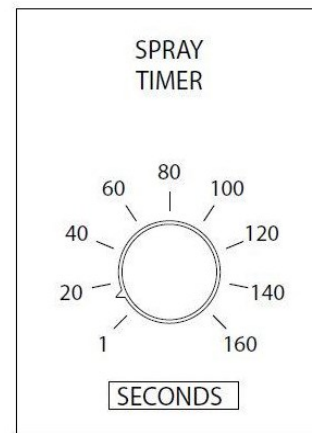

Figure 5-7-2
Spray Timer

Spray Odor Control - Maintenance

Compressor

The air pressure is factory set at 20 psi. If the solution is not being pulled up through the pick-up tube adjust the pressure slightly up or down until it climbs up the tube.

Nozzle

To obtain the best performance from your nozzle, it may become necessary to clean it periodically. The nozzle may become clogged and cease spraying due to factors such as dust, foreign particles accumulated in the orifice, and/or leakage in the air or liquid section of the nozzle.

Spray Odor Control – Maintenance (Cont.)

The following procedure should be done to maintain the nozzle's performance:

1. Check the air line, which is connected from the compressor unit to the compression fitting and threaded into the air inlet side of the nozzle, for any leakage.
2. Check the liquid suction line, which is connected to the liquid inlet side of the nozzle, and ensure that it is immersed in the odor control solution.
3. If it appears that the nozzle is only blowing air and does not lift the odor control solution out of the container, do the following:
 - a) Remove the cleanout plug from the nozzle body and, using a very thin pin or wire, clean the hole in the fluid cap (orifice) and replace the cleanout plug.
 - b) Remove the foot valve from the liquid container and inspect screen for clogging. Brush clean if clogged.

Spray Odor Chemical

In order for the spray odor system to work correctly the system must be supplied with a chemical solution. This solution in conjunction with the delivery nozzle system that finely atomizes the spray is what makes the system work. We recommend the use of FORMULA GS-710. This material has been effective at removing between 80% and 90% of the odors from the kitchen exhaust in many applications. For the contact information of the nearest FORMULA GS-710 distributor, contact Gaylord Industries.

Gaylord Industries

10900 SW Avery Street

Tualatin, OR 97062

Phone: (800) 547-9696

Exhaust Fan – Initial Set-Up

Overview

The exhaust fan in the ClearAir Unit is a heavy duty type. The size of the fan, motor, and drives has been chosen for the most efficient operation.

Initial Set-Up

For shipping purposes the leveling bolt on the spring isolators under the fan have been screwed down and the entire fan assembly strapped down. To set up the fan properly proceed as follows:

1. Cut the shipping straps and remove.
2. There are up to a total of six spring isolators, one on each of the four corners and possibly two more in the mid-section of the fan. The four on each corner are factory screwed down to help secure the fan during shipment. The two isolators at the motor end can be easily reached for adjustment. The two on the wheel end of the fan are accessed through the fan inlet plenum chamber by removing the two access panels in the chamber (Refer to Figure 6-2-1). Once the access panels are removed back off the leveling bolts on all four isolators until the fan is level and floating freely.
3. Tighten the lock nuts and replace the access panels.

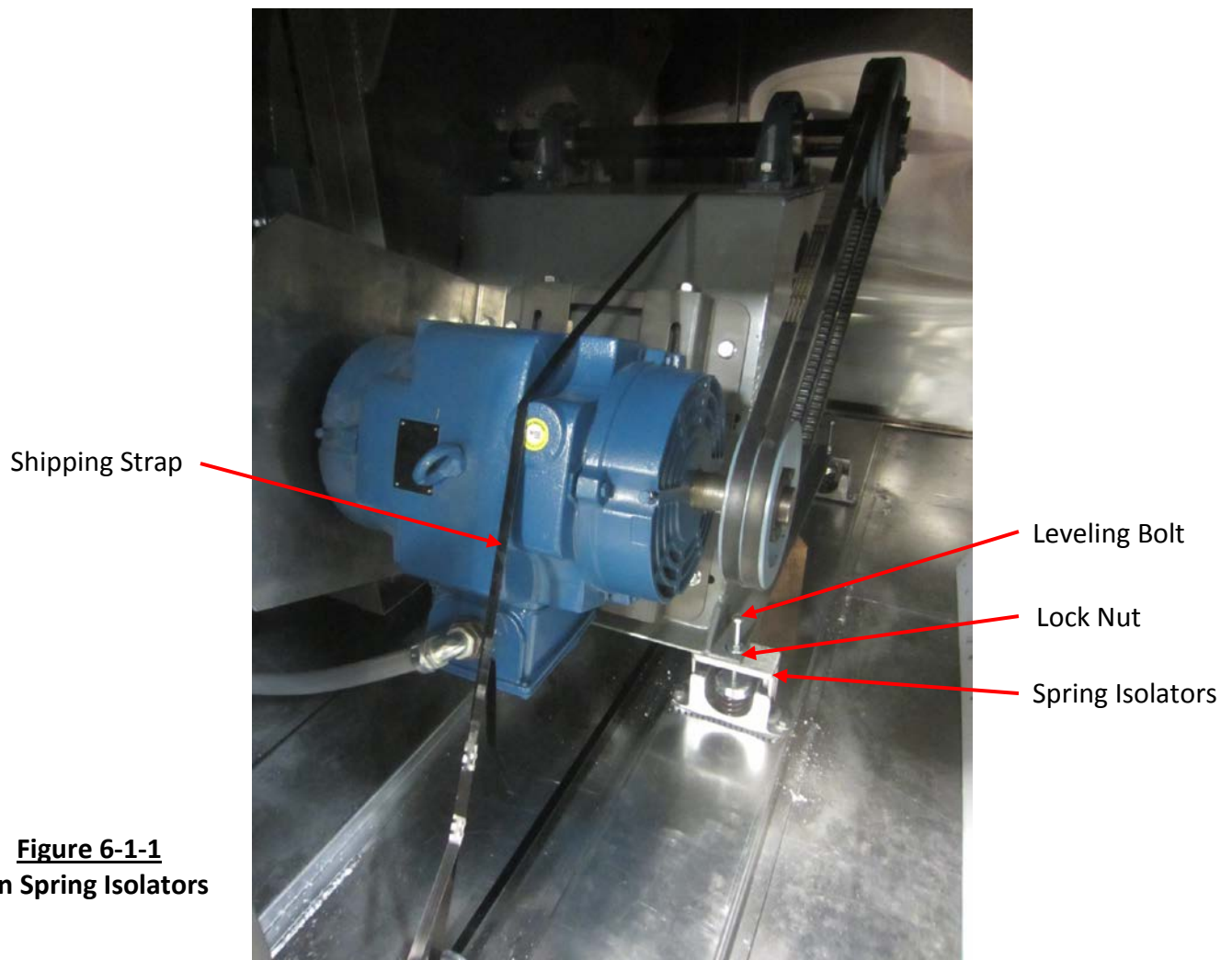

Figure 6-1-1
Fan Spring Isolators

Exhaust Fan – Initial Set-Up (Cont.)

Access Panels to
Spring Isolators

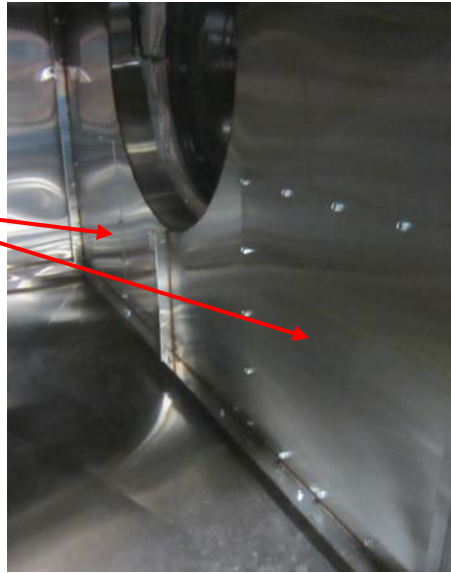

Figure 6-2-1
**Access to Spring
Isolators**

Pre-Operational Maintenance

Before starting the exhaust fan perform the following pre- operational maintenance:

1. Set screws & Belts:
 - a) Rotate fan impeller to check for shifting that may have occurred during shipment. If necessary, shift wheel position and re-tighten.
 - b) Check belt and pulley alignment.
 - c) Check tightness of setscrews in blower wheel hub.
 - d) Check tightness of set screws in bearing locking collar.
 - e) Check tightness of set screws in motor and fan pulleys.
 - f) Check tightness of all frame bolts and base bolts.
 - g) Check tightness of bearing mounting bolts.

2. Belt tension:
 - a) The deflection of the belt is approximately 1/4 inch per foot of center distance when firmly pressing the belt in the center.
 - b) If the belt does not have the proper deflection, adjustment is accomplished by use of adjustable motor base.

Initial Fan Lubrication

To prevent corrosion, bearings should receive grease and be rotated. Proceed as follows:

1. Completely fill the bearings with grease or moisture-inhibiting oil. Loren Cook Company uses petroleum lubricant in a lithium base. For best results, lubricate the bearings while turning the fan wheel. Pump grease in slowly until a slight bead forms around the bearing seals. Excessive grease can burst seals thus reducing bearing life.

Exhaust Fan – Initial Set-Up (Cont.)

Idle Fan Requirements

1. If the fan is going to sit idle for any length of time, rotate the wheel several revolutions every three to five days to keep a coating of grease on all internal bearing parts. Turn the wheel by hand while greasing bearings. A clean 1/16" bead of grease must appear on each side of each bearing. Refer to specific bearing lubricating instructions on the fan housing.

Initial Operation

After pre-operational checks, unit is ready for operation. Start the exhaust fan and check the following:

1. There is a rotation arrow on the fan housing. Check for proper rotation.
2. Excessive vibration.
3. Unusual noise.
4. Bearing noise.
5. Improper belt alignment or tension (listen for squealing).

If a problem is discovered, immediately shut the fan off. Lock out all electrical power and check for the cause of the problem and repair.

Exhaust Fan - Preventive Maintenance

Every six months conduct the following maintenance:

Extreme Caution: Before performing any maintenance on the exhaust fan always shut off the electrical power to the fan by disconnect switch located on the ClearAir unit Main Electrical Panel (Refer to Figure 4-23-1). Place a sign on the Command Center or any other control that starts the exhaust fan stating "Do Not Start Fan. Fan Maintenance In Process".

1. Inspect bolts and setscrews for tightness. Tighten as necessary. Worn setscrews should be replaced immediately.
2. Inspect belt wear and alignment. Replace worn belts with new belts and adjust alignment as needed.
3. Check for condition of the belts. Replace cracked, glazed or frayed belts.
4. Check for proper deflection of the belt. The deflection of the belt is approximately 1/4 inch per foot of center distance when firmly pressing the belt in the center. If the belt does not have the proper deflection, adjustment is accomplished by use of adjustable motor base.
5. Lubricate the bearings. Before lubrication, the grease nipple and immediate vicinity should be thoroughly cleaned without the use of high pressure equipment. Completely fill the bearings with grease or moisture-inhibiting oil. Loren Cook Company uses petroleum lubricant in a lithium base. For best results, lubricate the bearings while turning the fan wheel. Pump grease in slowly until a slight bead forms around the bearing seals. Excessive grease can burst seals thus reducing bearing life. In the event the bearings cannot be seen, use no more than three injections with a hand operated grease gun.

Exhaust Fan - Troubleshooting

Chart C-6-4-1
Exhaust Fan Troubleshooting

Troubleshooting – Exhaust Fan		
Symptom	Probable Cause	Corrective Action
Reduced Airflow	1. Fan wheel turning in the wrong direction. **	1. Re-wire fan motor.
	2. Belt slippage or broken belt.	1. Tighten or replace belt.
	3. Magnetic starter overload cut out.	1. Push starter reset button. If overloads continue to cut out search for cause.
Noise in exhaust fan.	1. Bad fan bearings.	1. Replace bearings
	2. Loose tie rods or blades	1. Replace fan wheel.
	3. Fan wheel loose on shaft	1. Tighten wheel.
	4. Foreign objects located in fan wheel or fan housing.	1. Clean the fan wheel.

****Warning:** Running the fan backwards will overheat the motor and can cause bearing failure or other serious damage and will void the Warranty.

Parts – Miscellaneous

Overview

The parts shown on the following pages are available from a Gaylord Certified Service Agency (CSA). For the location of your nearest CSA please go to www.galordventilation.com and click on Service Agency Locator.

Table T-7-1-1
Parts List - Miscellaneous

PC #	Description	Gaylord Part #	Photo/Illustration
1	Spray Nozzle	19717	
2	Wash Manifold Oscillating Motor	19700	
3	Brass Swivel Elbow "O" Rings	Special Order	
4	Shaft Collar	19859	
5	Rubber Oil Seal	18797	

Parts – Miscellaneous – Cont.

Table T-7-2-1
Parts List Miscellaneous (Cont)

PC #	Description	Gaylord Part #	Photo/Illustration
1.	Quick Disconnect	10324 20323	
2.	1/4 Turn Door Latch Key for Latch	19547 19548	
3.	Lift and Turn Latch	16547	
4.	"T" Handle Latch	19771	
5.	Fire Thermostat 15" Length, 250°F., Normally Open	18782	
6.	Water Solenoid Valve Slow Close – 1-1/4"	10144	
7.	Water Solenoid Valve Repair Kit – 1-1/4" – 8221G9	14390	
8.	Coil for Water Solenoid Valve – 120V	10156	

Parts – Miscellaneous – Cont.

Table T-7-3-1
Parts List Miscellaneous (Cont.)

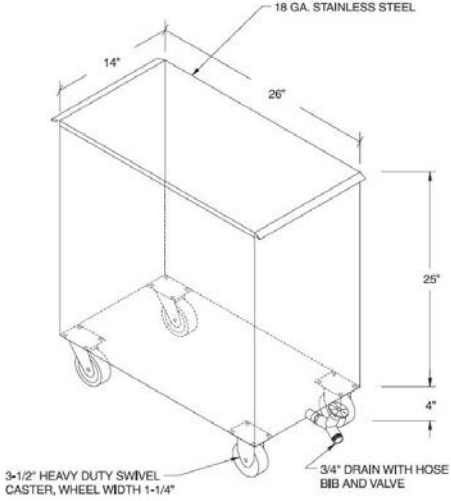
PC #	Description	Gaylord Part #	Photo/Illustration
	Soak Tank (24" Cells)	12801	
1	Debris Screen	30167	Not Illustrated
2	Impactor Filter	20006	
3	Moisture Separator	30080	
4	Vermiculite Gasket	10879	
5	Orange Silicone Gasket	18993	
6	Bulb Seal Gasket for Access Doors	20123	

Parts – ESP Cells

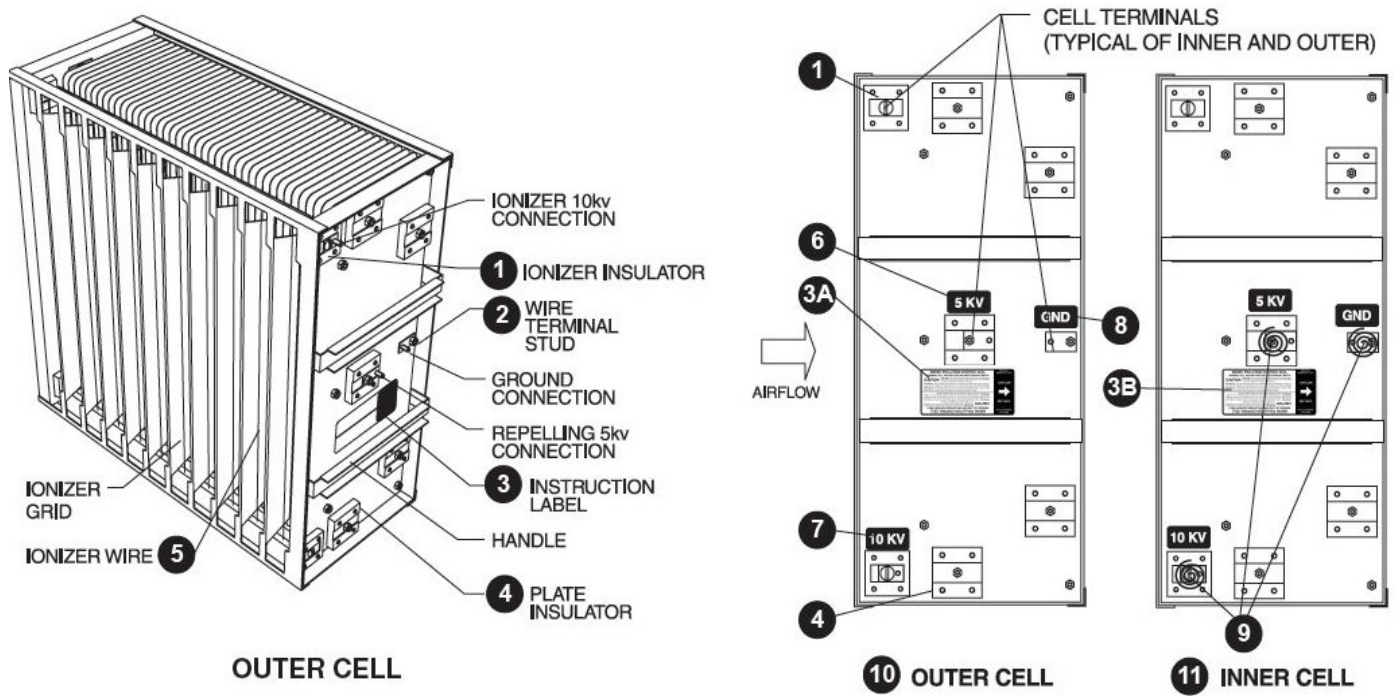

Figure 7-4-1
ESP Cells

Table T-7-4-1
Cell Parts List

PC #	Description	Gaylord Part #
1	Ionizer Insulator (same as Plate Insulator)	19833
2	Wire Terminal Stud	14753
3A	Instruction Label – Outer Cell	16846
3B	Instruction Label – Inner Cell	16844
4	Plate Insulator (same as Ionizer Insulator)	19883
5	Ionizer Wire	10338
6	5 KV Label	16999
7	10 KV Label	17000
8	Ground Label	16998
9	Inner Cell Coil Spring	11301
10	Outer Cell - Complete	76131
11	Inner Cell – Complete	76132

Parts – Electrical Compartment

Table T-7-5-1
Electrical Compartment Parts List

PC #	Description	Gaylord Part #
1	Cell Access Door Safety Switch Not Illustrated	30431
2	High Voltage Transformer/Power Supply (for 1-4 Cells)	16514
3	Electrical Compartment Plunger Safety Switch	12798
4	Cooling Fan	30424
5	Cell Status Light (Green) Not Illustrated	12512
6	Cell High Voltage Cable (6 ft. Lengths)	15228
7	Cell Terminal Connector Cover (90 Degree Rubber Boot)	10332
8	Spark Plug, Cell Terminal Connectors	10355

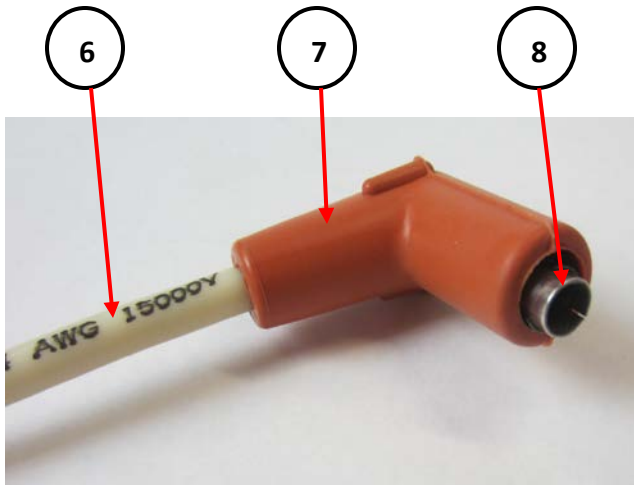

Figure 7-5-2
Cell High Voltage Cable with Connectors

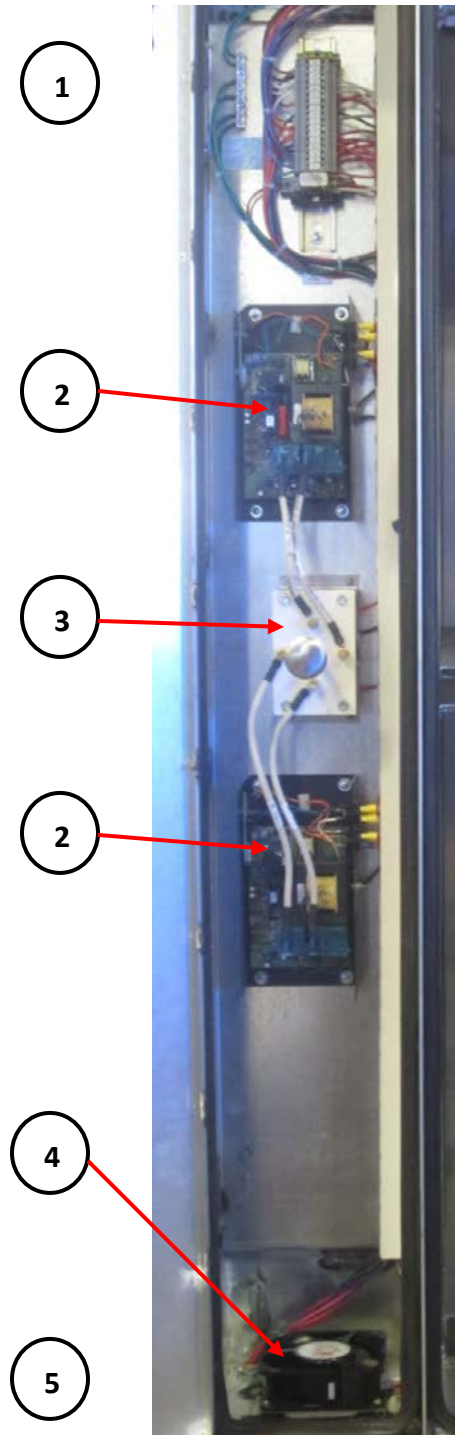

Figure 7-5-3
Electrical Compartment

Parts – Main Electrical Compartment

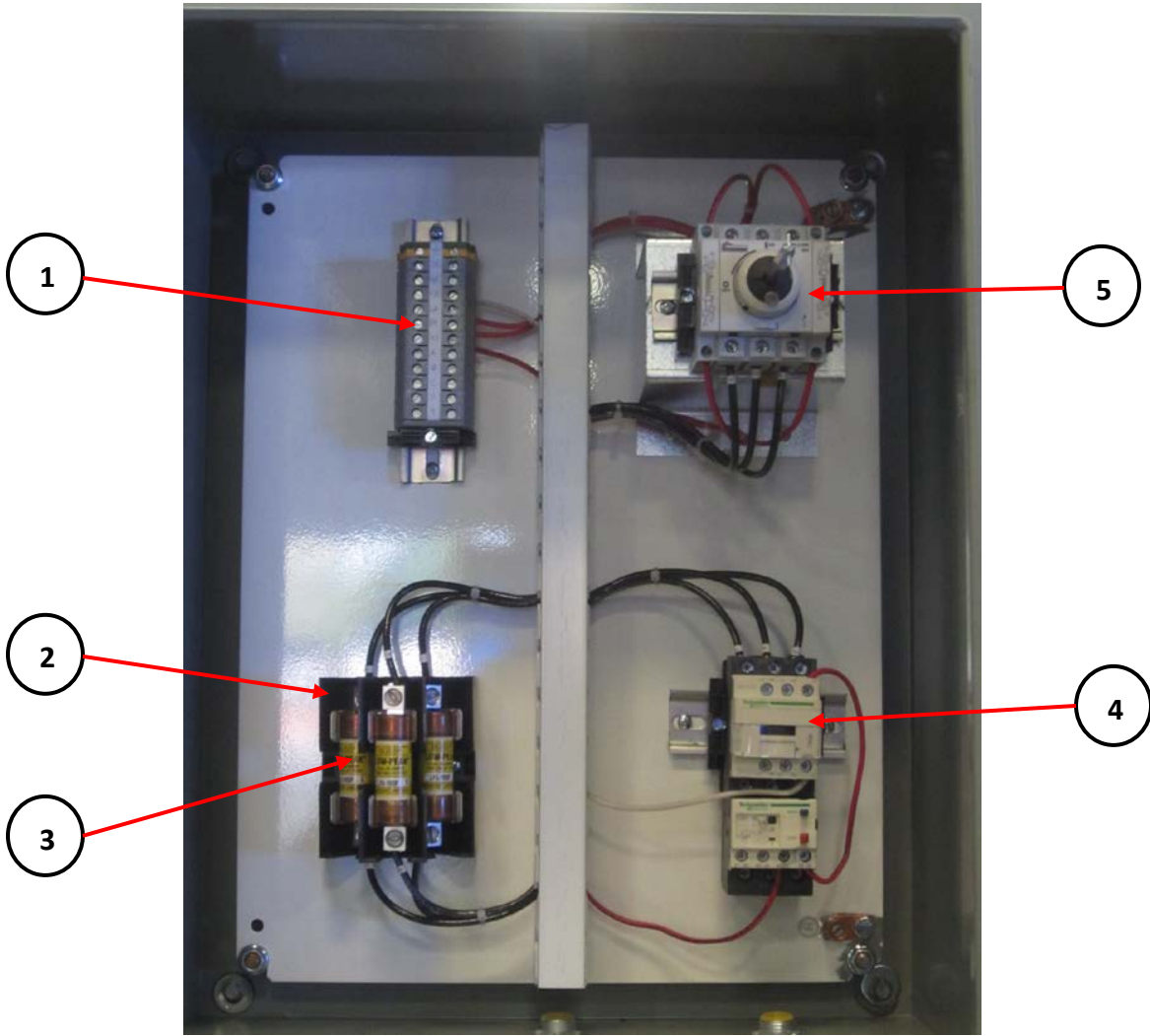

Figure 7-6-1
Main Electrical Compartment

Table T-7-6-1
Main Electrical Compartment Parts List

PC #	Description	Gaylord Part #
1	Terminal Block(Refer to Gaylord submittal drawings for part #)	Varies
2	Fuse Block (Refer to Gaylord submittal drawings for part #)	Varies
3	Fuses (Refer to Gaylord submittal drawings for part #)	Varies
4	Motor Starter (Refer to Gaylord submittal drawings for part #)	Varies
5	Disconnect Switch (Refer to Gaylord submittal drawings for part #)	Varies

Parts – Wash Control Cabinet

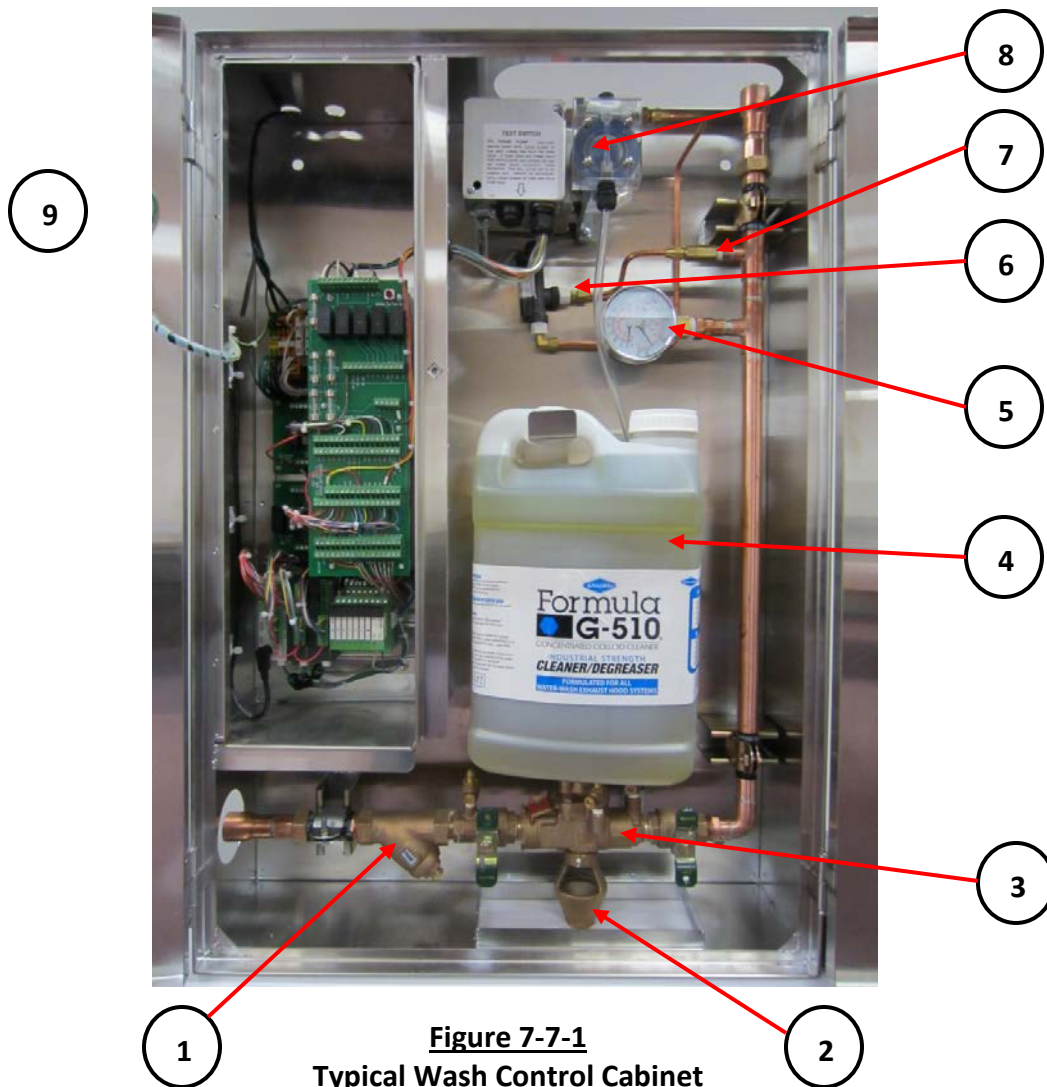

Figure 7-7-1
Typical Wash Control Cabinet

Table T-7-7-1

Washdown Control Cabinet Plumbing Parts List		
PC #	Description	Gaylord Part #
1	Line Strainer – 1.25"	17140
2	Air Gap Assembly for Backflow Preventer for 1.25"	50287
3	Reduced Pressure Principle Backflow Preventer – 1.25"	11319
4	Detergent Container	19793
5	Pressure - Temperature Gage	10175
6	Detergent Flow Switch	16892
7	Detergent Check Valve – Brass .25"	10246
8	Detergent Pump	10222
9	Command Center Guard (not shown - package of 2)	75587
10	Door Latch (not shown)	19351

Parts –
Detergent Pump

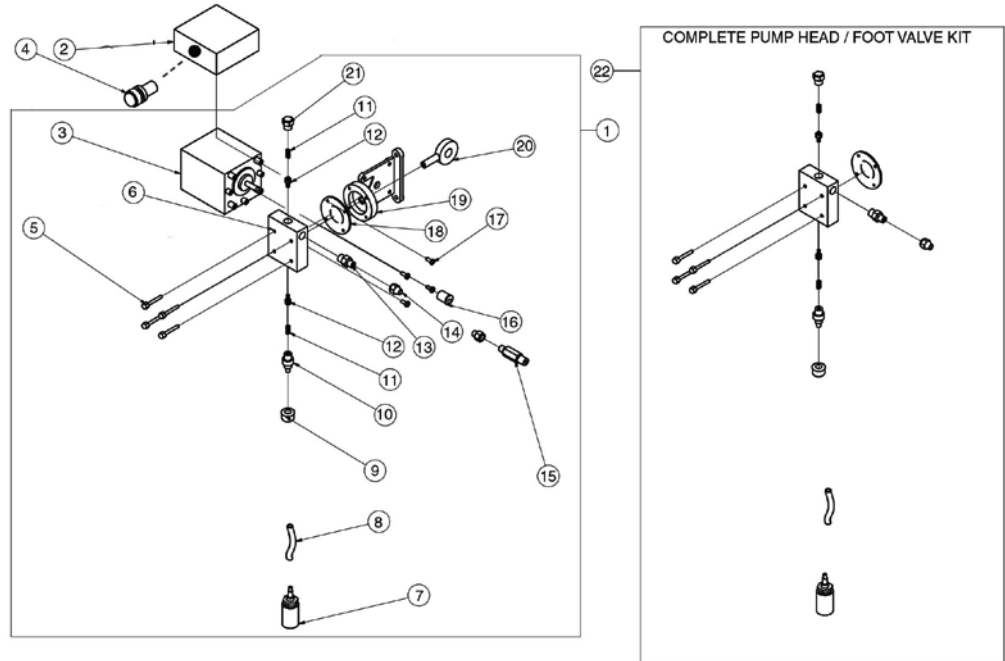

Figure 7-8-1
Detergent Pump
Exploded View

Table T-7-8-1

Detergent Pump Parts List			
Pc #	DECRPTION	QTY	GAYLORD PART NO.
1	Detergent Pump - Complete	1	10222
2	Electrical J-Box (not sold separately)	1	na
3	Pump Motor (not sold separately)	1	na
4	Detergent Pump Test Switch	1	10238
5	Pump Head Screws (sold with Kit Part No. 10275)	4	na
6	Pump Head, Sold as a Kit. See Part No 10275	1	na
7	Foot Valve	1	10269
8	Vinyl Tubing 22" Long	1	10272
9	Tube Nut (not sold with Kit Part No. 10275)	1	na
10	Bottom Adaptor with "O" Ring (sold with Kit Part No. 10275)	1	na
11	Spring (sold with Kit Part No. 10275)	1	na
12	Poppet Check (sold with Kit Part No. 10257)	2	na
13	Brass Outlet (sold with Kit Part No. 10275)	1	na
14	Tube Nut - Brass (sold with Kit Part No. 10275)	1	na
15	Check Valve - Brass	1	10265
16	Adjustable Cam Assembly	1	20466
17	Bracket Motor Mounting Screws (not sold separately)	4	na
18	Diaphragm (sold with Kit Part No. 10275)	1	na
19	Pump Bracket (not sold separately)	1	na
20	Yoke and Bearing Assembly	1	na
21	Top Cap (sold with Kit Part No. 10275)	1	na
22	Complete Pump Head / Foot Valve Kit	1	10275

Parts – Spray Odor Control

Pieces 5 and 6 not shown

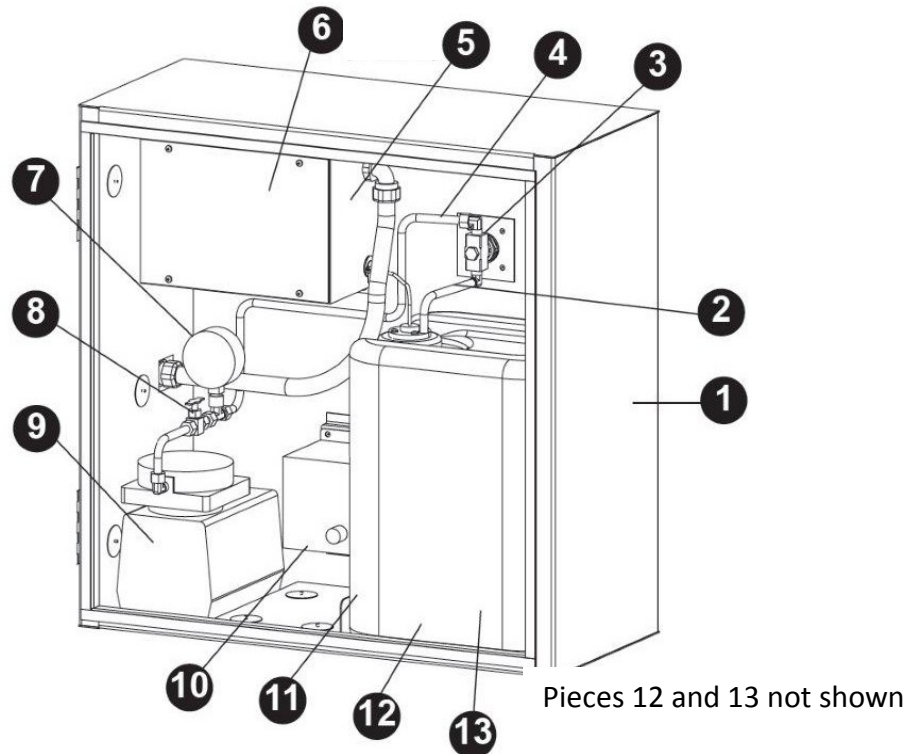

Figure 7-9-1
Spray Odor Control Cabinet

Table T-7-9-1

Odor Control Parts List		
PC #	Description	Gaylord Part #
1	Spray Odor Control Cabinet	19119
2	1/4" I.D. Flexible Suction Tube	10272
3	Spray Nozzle Assembly	19065
4	3/8" Copper Tubing	11000
5	Electrical Box	N/A
6	Cycle and Spray Timer Relay	19073
7	Pressure Gauge	10276
8	Needle Valve	19070
9	Air Compressor	19072
10	Heater	19075
11	5 Gallon (18.9 Liter) Container of GS-750	19097
12	Spray Chemical Level Sensor (In Tank)	19071
13	1/4" Foot Valve (In Tank)	10269

This Page Intentionally Left Blank

Wiring Diagrams

The Wiring Diagrams on the following pages are typical for Typical ClearAir Units and may not represent your installation. Always refer to the Gaylord submittal drawings for the actual Wiring Diagrams for your installation.

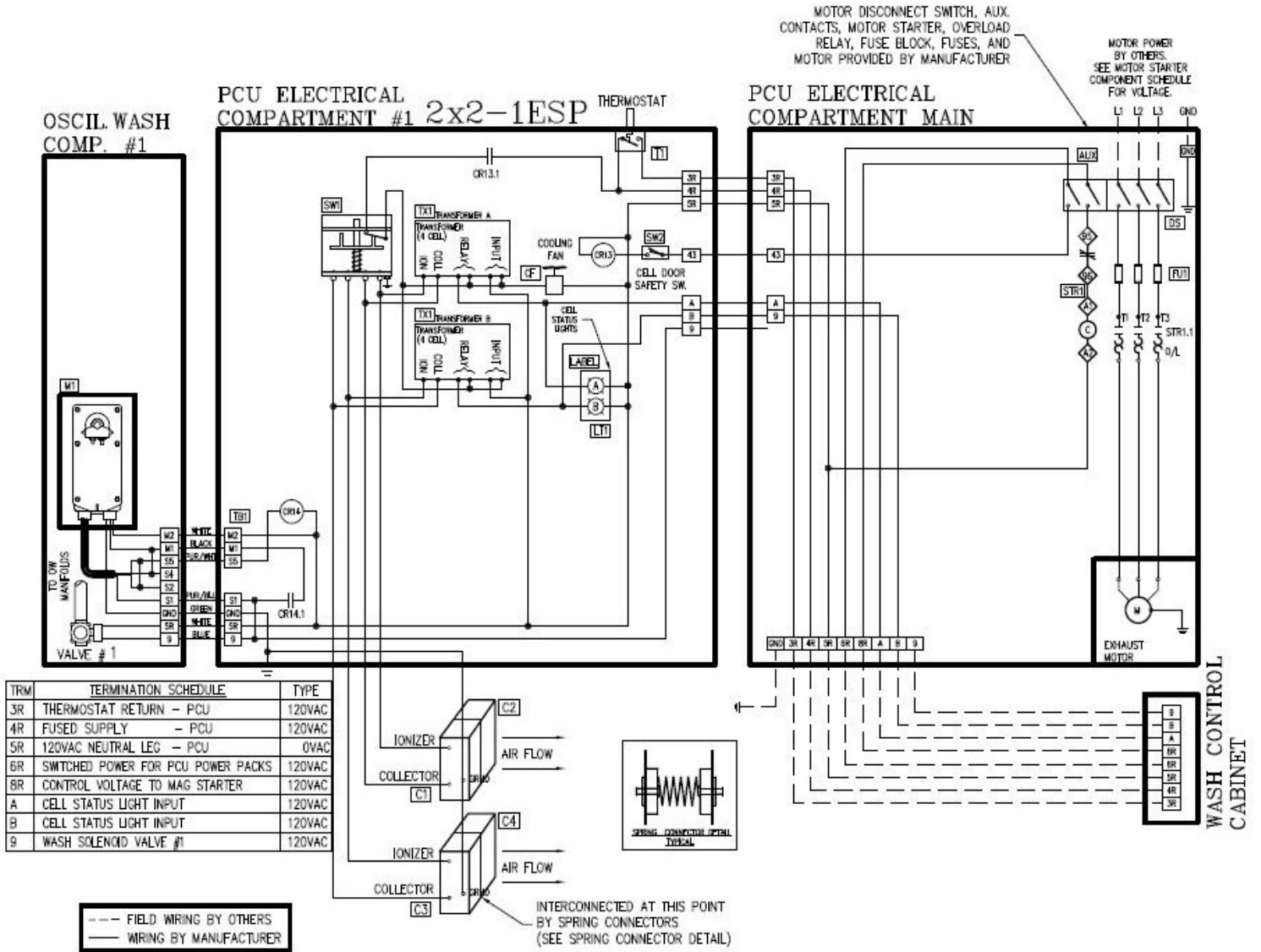

Figure 8-1-1
Wiring For 2x2-1ESP

Wiring Diagrams - Cont.

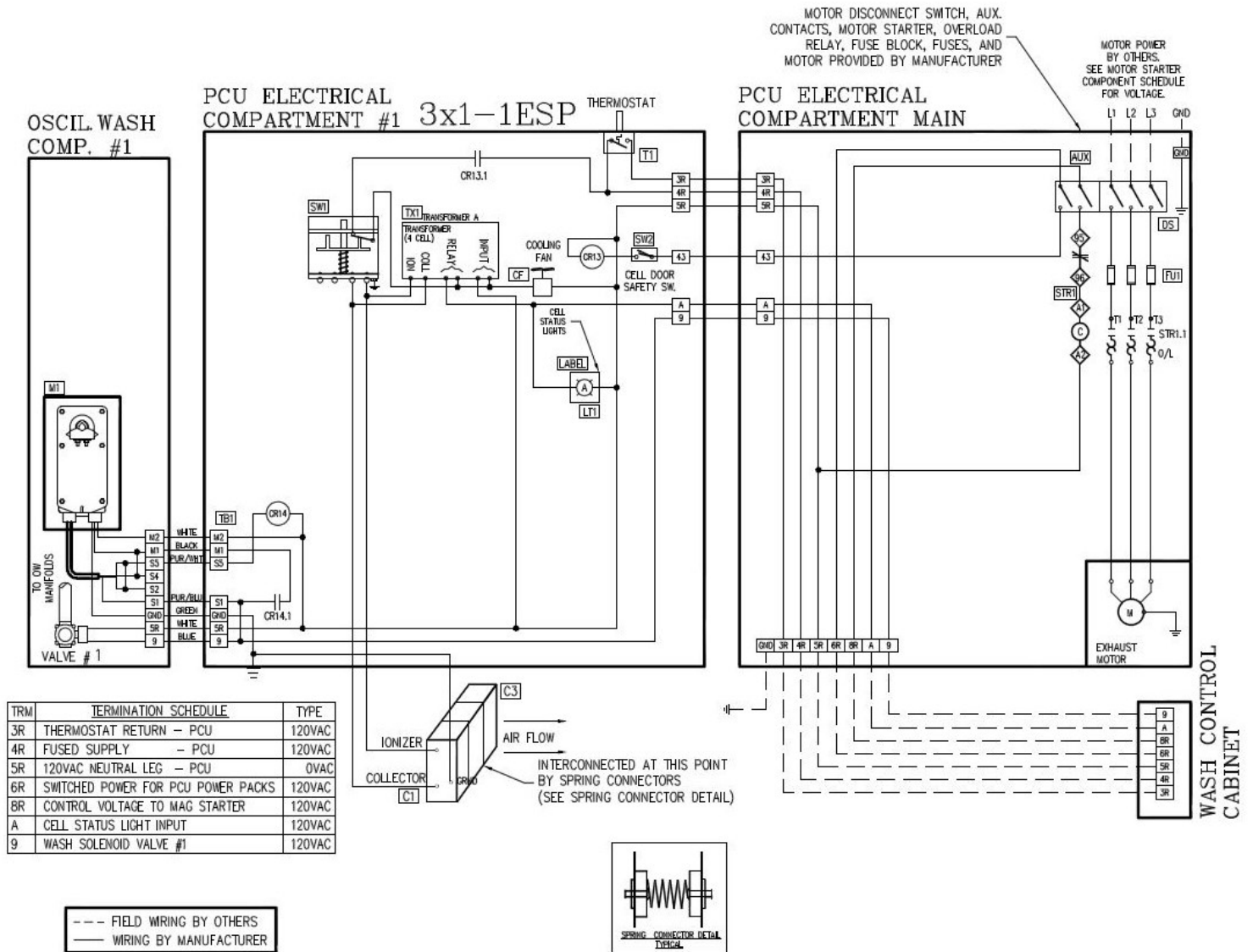

Figure 8-2-1
Wiring For 3x1-1ESP

Wiring Diagrams - Cont.

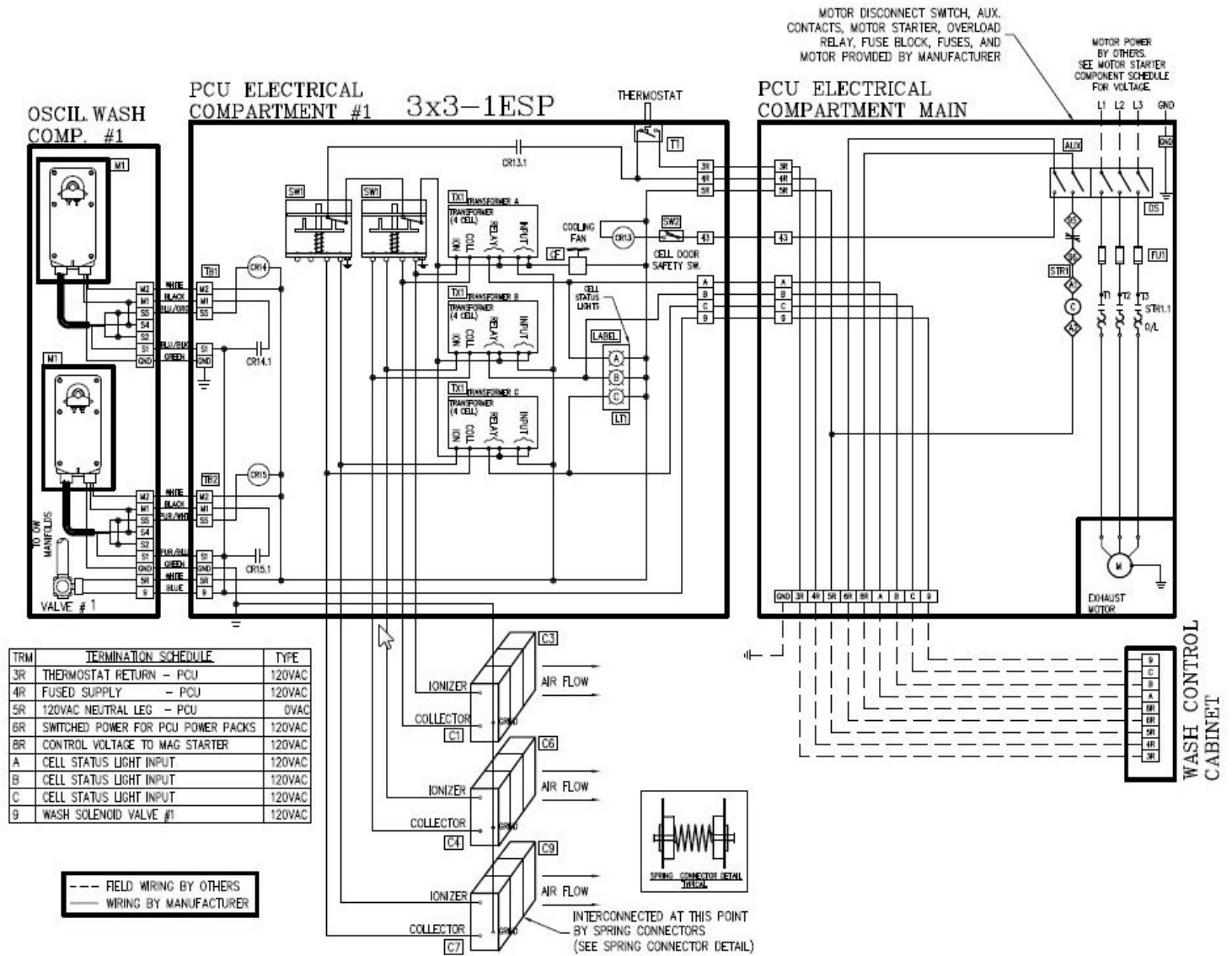

Figure 8-3-1
Wiring For 3x3-1ESP

Wiring Diagrams - Cont.

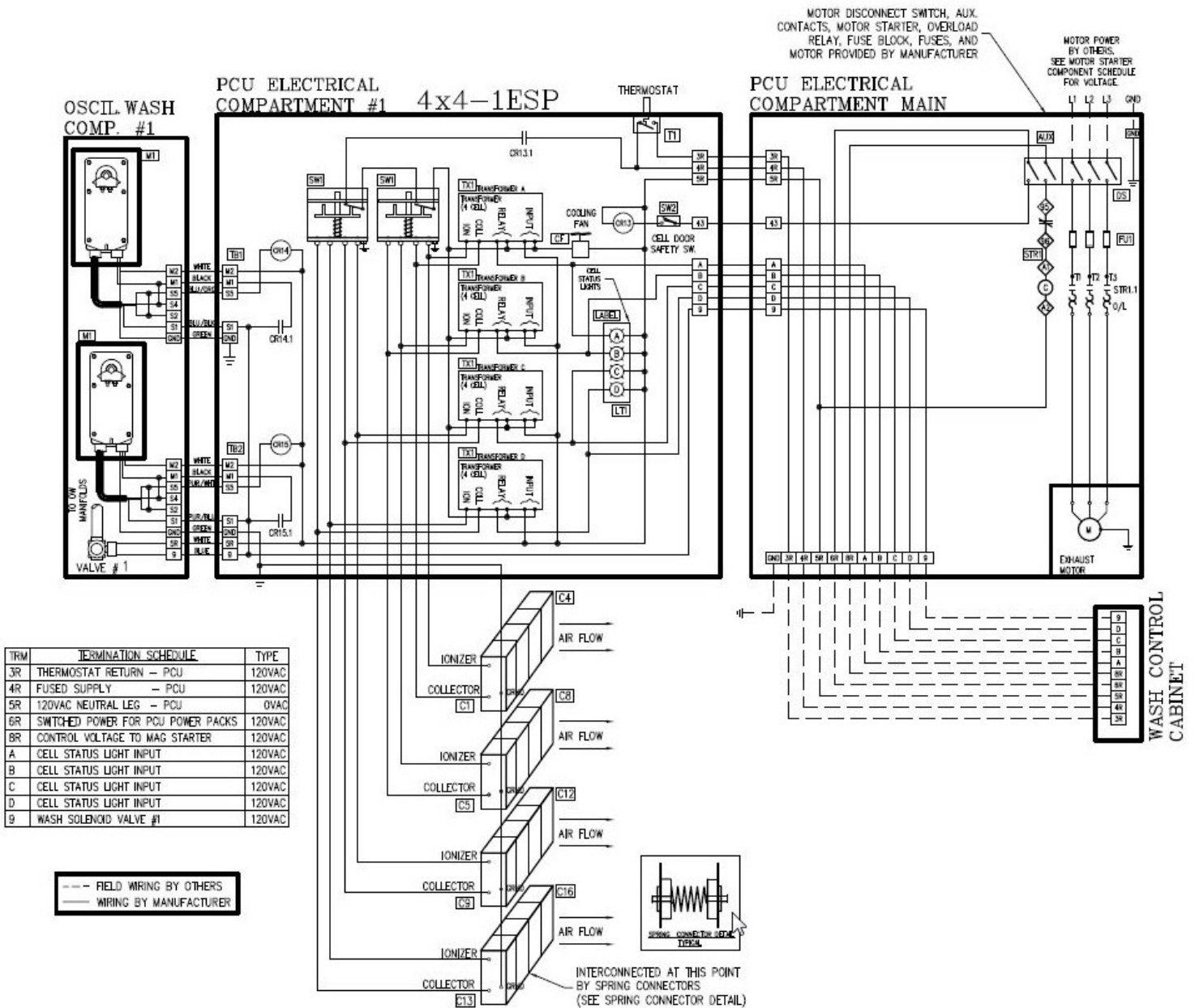

Figure 8-4-1
Wiring For 4x4-1ESP

Wiring Diagrams - Cont.

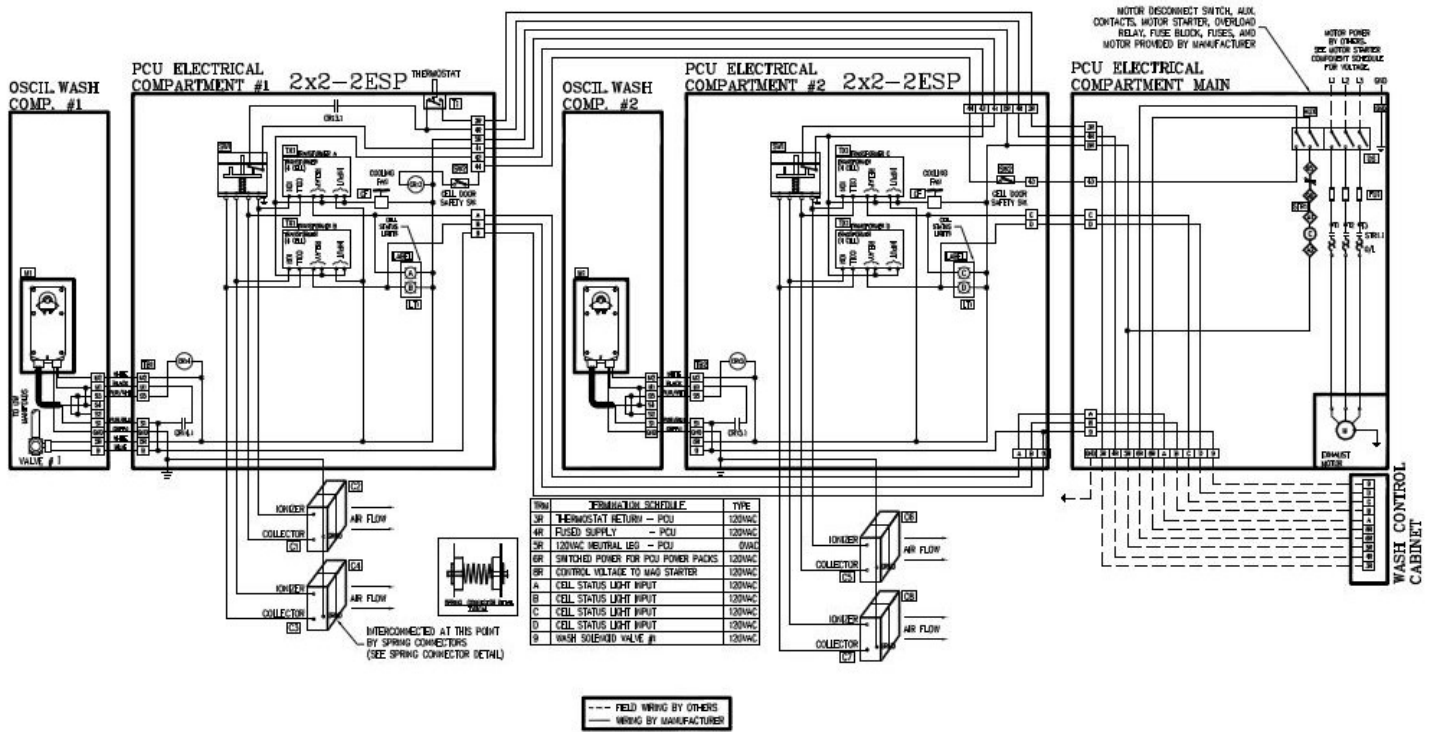

Figure 8-5-1
Wiring For 2x2-2ESP

Wiring Diagrams - Cont.

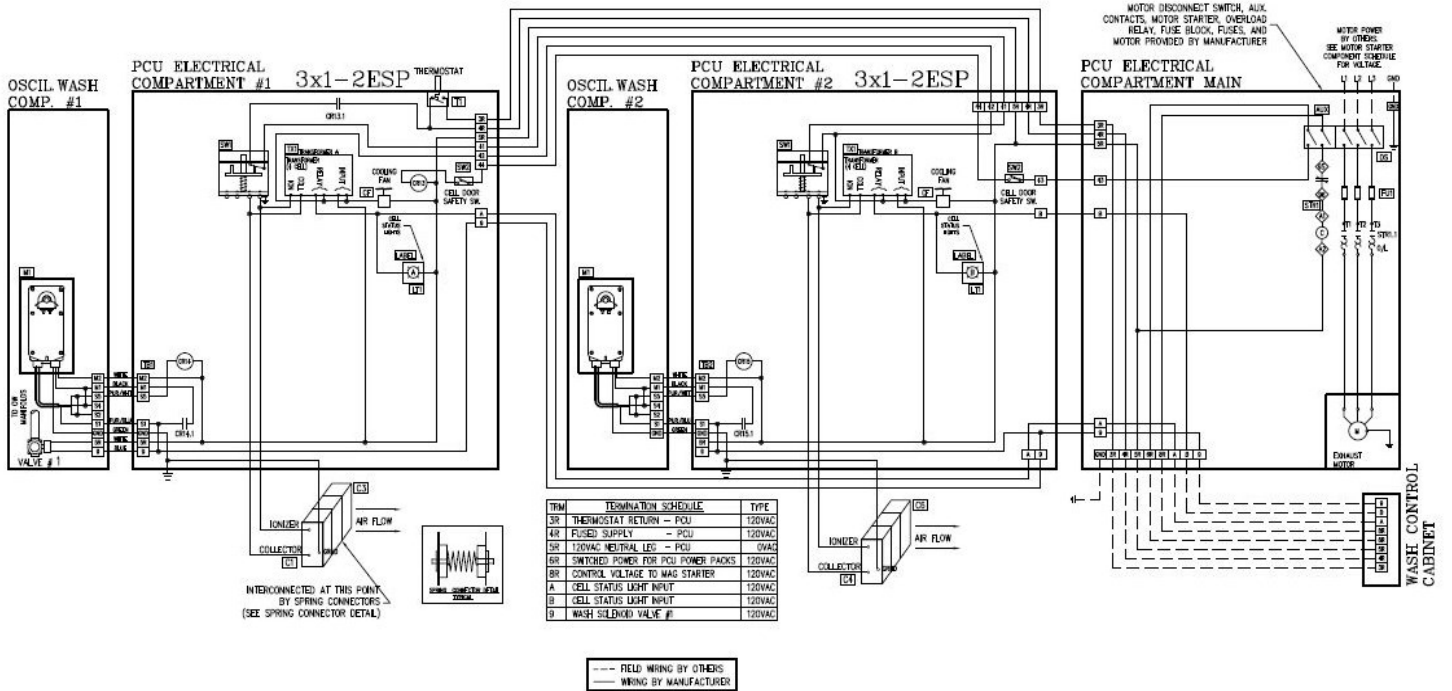

Figure 8-6-1
Wiring For 3x1-2ESP

Wiring Diagrams - Cont.

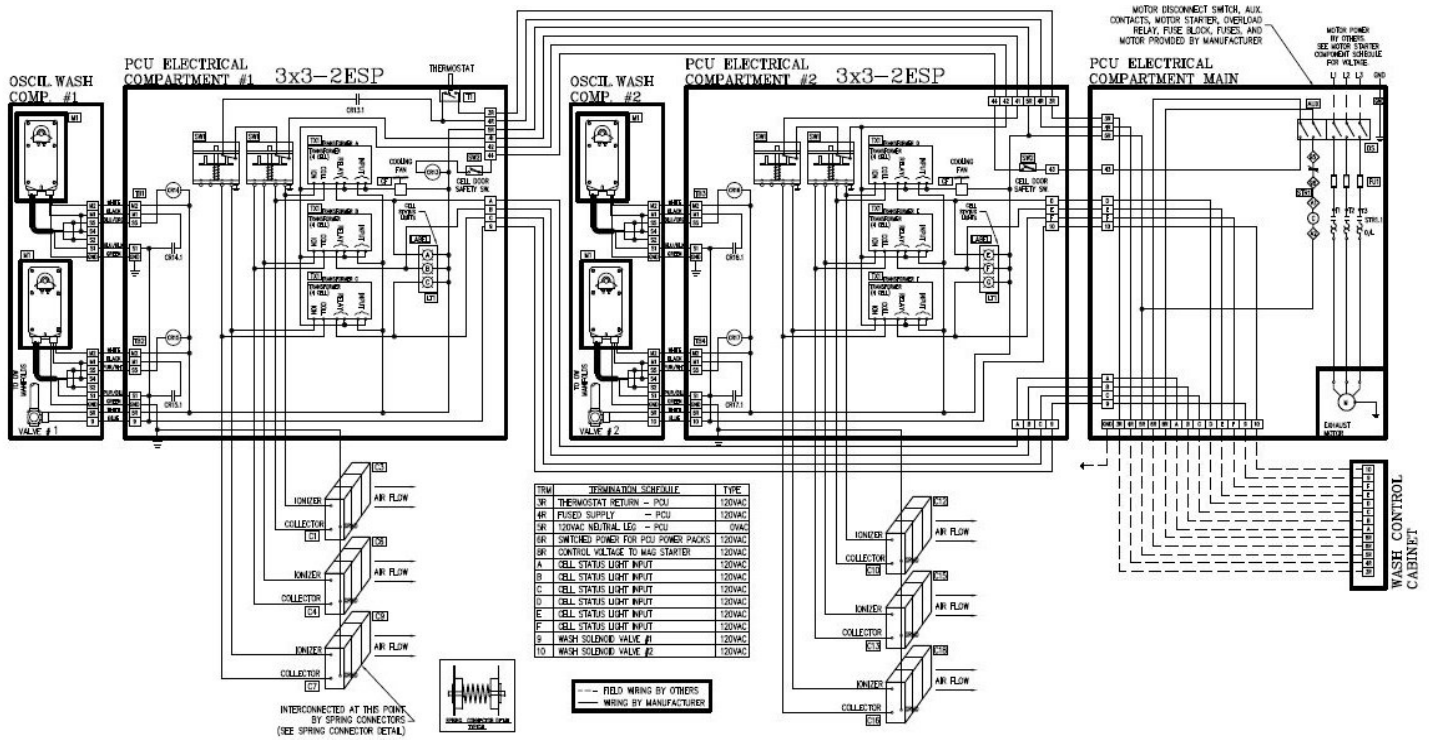

Figure 8-7-1
Wiring For 3x3-2ESP

Wiring Diagrams - Cont.

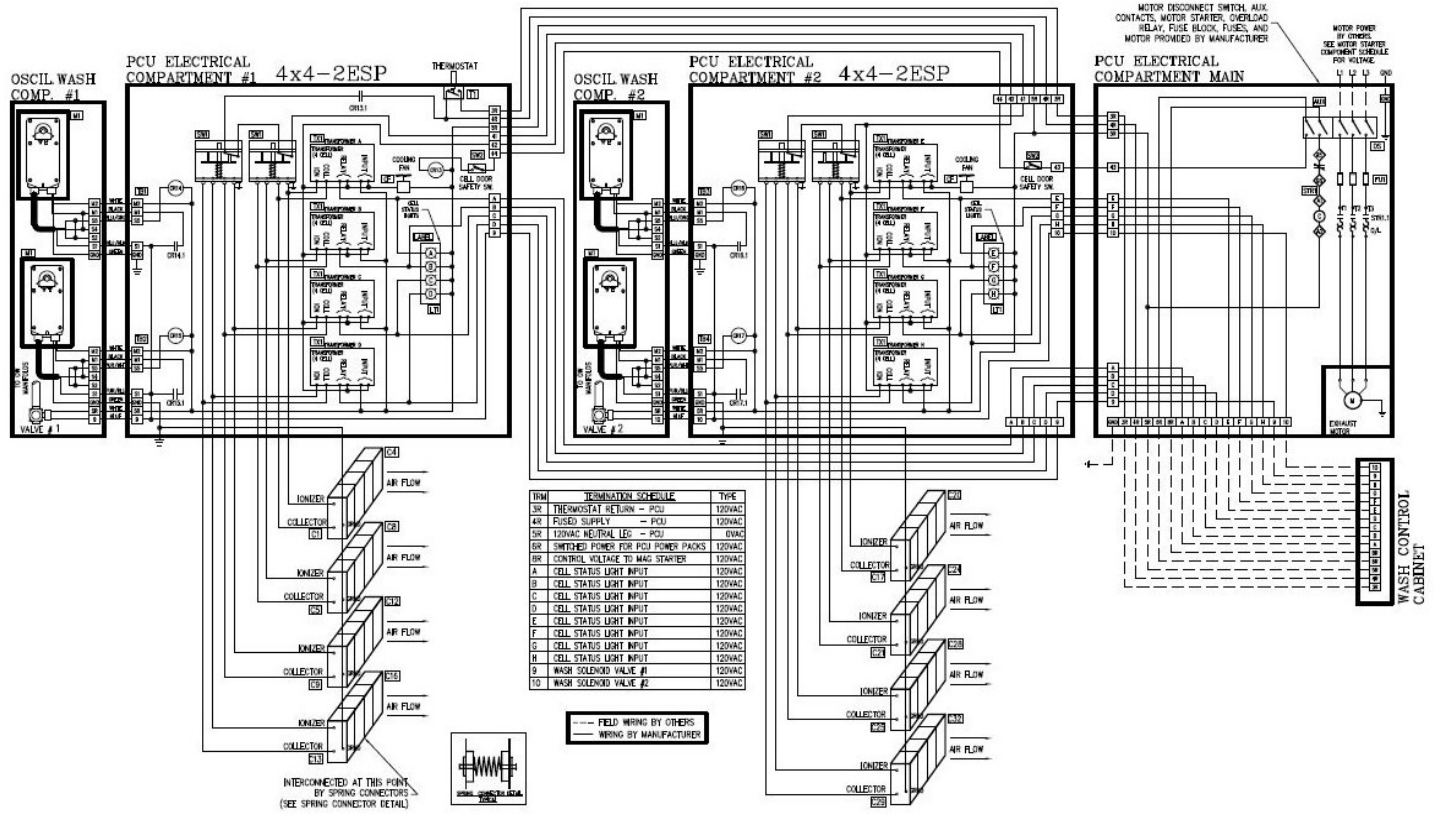

Figure 8-8-1
Wiring For 4x4-2ESP

Receiving

Overview

Most ClearAir units are shipped in one piece. However, some units, because of size or special jobsite conditions, may be shipped in multiple sections. Follow the instructions provided with the unit to join the sections back together.

Receiving

If the unit includes media bed odor control, the media panels are packaged separately. Verify against the shipping documents that you have received all items and note any shipping damage, obvious or hidden, to your carrier and on your Bill of Lading. If damage is found, immediately file a claim with the transport company. All units are thoroughly inspected and fully operation tested at the factory prior to shipment.

Verify that the electrical and air flow ratings on the unit nameplate agrees with jobsite requirements. If a contradiction arises notify the factory prior to proceeding with installation.

Safety Considerations

Installing and servicing the ClearAir unit can be hazardous due to the presence of electrical components. Only trained and qualified service personnel should install or service this equipment.

Untrained personnel can perform basic maintenance, such as cleaning and replacing filters. All other operations should be performed by trained service personnel. When installing or servicing, observe precautions in literature and on tags and labels attached to unit.

Follow all safety codes. Wear safety glasses and work gloves. Use quenching cloth for brazing operations. Have fire extinguisher available. Read these instructions thoroughly.

Odor Control Media Short Term Storage

Units that include media bed odor control, the media panels are shipped separate from the unit. The media panels must be stored in a dry place with less than 95% relative humidity.

Exhaust Fan Receiving and Storage

If the unit is equipped with an exhaust fan and if it is going to sit idle for any length of time the following must be done:

1. Completely fill the bearings with grease or moisture-inhibiting oil. Loren Cook Company uses petroleum lubricant in a lithium base. For best results, lubricate the bearings while turning the fan wheel. Pump grease in slowly until a slight bead forms around the bearing seals. Excessive grease can burst seals thus reducing bearing life.
2. Rotate the wheel several revolutions every three to five days to keep a coating of grease on all internal bearing parts.

If the unit is stored outdoors in addition to lubricating as described above the following must be done:

1. Coat the shaft with grease or a rust preventative compound.
2. Wrap bearings for weather protection.
3. Cover the exhaust outlet to prevent the accumulation of dirt and moisture in the housing.

Rigging

Instructions

All units are provided with a minimum of four (4) lifting points for rigging attachment. **WARNING:** Use all lifting points provided (Refer to Figure A-2-1). Spreader bars are mandatory to prevent contact and damage to the unit by lifting hooks, straps, cables, or chains. Consult the mechanical or structural engineer before moving the unit across the roof deck.

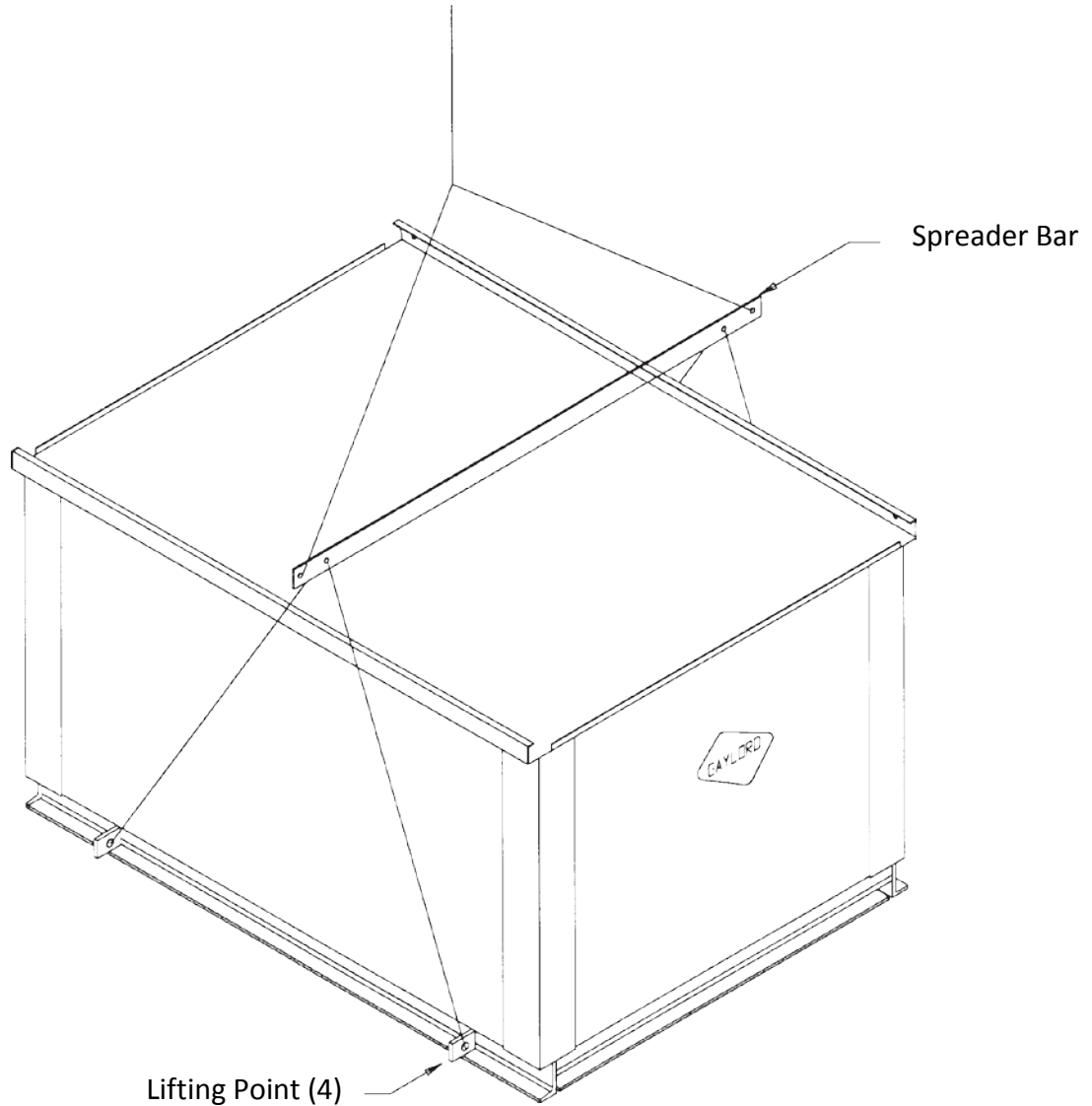

Figure A-2-1
Typical Rigging

Assembly

Overview

Typically, ClearAir units are shipped as one piece and no unit assemble is required. Sometimes, for building accessibility reasons, the unit is shipped in multiple pieces. If this is the case, use the following instructions to assemble.

1. Attach ESP Smoke Control Section 1 to Odor Control Section 2

Bolt Section 1 and Section 2 bases together on the outer sides using the provided 3/4" holes. Tech screw the walls and roofs together using the provided 3/16" holes. From inside the unit, continuously weld the floor, wall, and roof seams water tight. From outside the unit stitch weld and fire seal along the seams.

2. Attach Odor Control Section 2 to Plenum Section 3

Bolt Section 2 and Section 3 bases together, on the outer sides using the provided 3/4" holes. From inside the plenum, tech screw the walls and roofs together using the provided 3/16" holes. Continuously weld the round fan inlet openings together. From outside the unit stitch weld and fire seal along the seams.

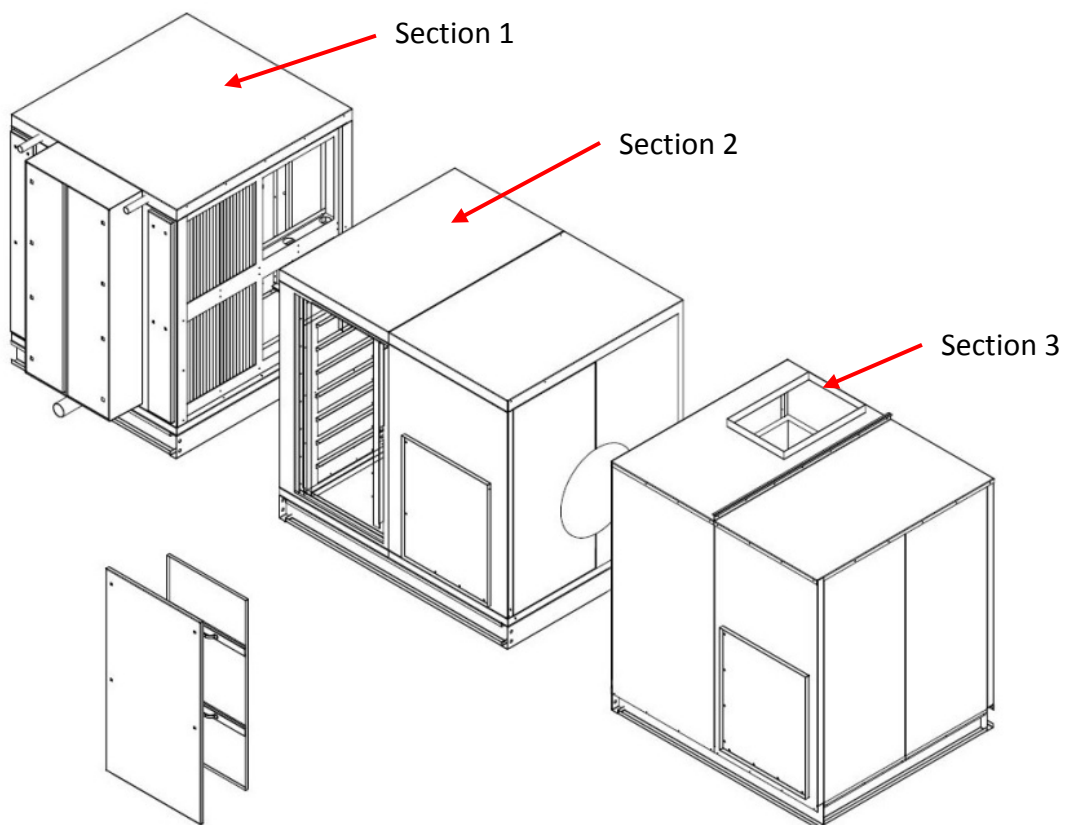

Figure B-1-1
Exploded View

This Page Intentionally Left Blank

Installation

Installation Codes

This unit requires external plumbing and electrical connections to be made in the field. It is recommended that the Authority Having Jurisdiction (AHJ) be consulted regarding local codes and installation procedures. Gaylord Industries is not responsible for obtaining necessary approvals and permits which may be required for installation, nor is it responsible for verifying that the unit has been installed in accordance with national, state, and local codes. In the absence of locally adopted codes use the current editions of the National Electrical Code and the Uniform Mechanical Code. Connections of the exhaust duct to the inlet and outlet of the ClearAir unit must be fully welded to comply with NFPA-96.

Installation Precautions

1. The services of qualified contractors are essential for safe and proper installation of this equipment.
2. The unit is designed for installation on a level surface.
3. When installed in an enclosed space a fire rated enclosure may be required for the unit and associated duct work. Consult the Authority Having Jurisdiction.
4. Consult the Authority Having Jurisdiction regarding distance requirements from the point of termination the exhaust outlet and any outside air intakes and/or adjacent structures or property lines.
5. Do not apply power to the unit until all electrical connections have been made and a pre-start-up preliminary inspection has been completed.
6. The NEC requires a minimum of 42 inches clearance in front of the Cell access door and the electrical compartment door for service and routine maintenance.

This Page Intentionally Left Blank

Nameplate



<div style="text-align: center;">  "ClearAir"[™] SMOKE POLLUTION CONTROL UNIT MODEL NUMBER <input style="width: 100%; height: 20px;" type="text"/> <input style="width: 100%; height: 20px;" type="text"/> SERIAL NUMBER <input style="width: 100%; height: 20px;" type="text"/> MEANUMBER <input style="width: 100%; height: 20px; text-align: center;" type="text" value="115-89-M VOL. 3"/> SUITABLE FOR USE WITH CONTROL MODEL NO. <input style="width: 100%; height: 20px;" type="text"/> <p style="text-align: center;">FOR EITHER INDOOR OR OUTDOOR INSTALLATION</p> <p style="text-align: center;">CAUTION - HIGH VOLTAGE 5,000 VOLT DC COLLECTOR VOLTAGE 10,000 VOLT DC IONIZER VOLTAGE</p> <p style="text-align: center;">GAYLORD INDUSTRIES 10900 S.W. AVERY STREET TUALATIN, OREGON 97062-8549</p> <p style="text-align: center;">FOR NAME OF THE NEAREST SERVICE AGENCY CALL: 800-547-9696 CONFORMS TO UL STD 867/710/ ULC646 CERTIFIED TO CSA STD C22.2 NO. 187</p> <div style="display: flex; justify-content: space-between; align-items: center;"> LA RR#7741 FORM NO. CANP 0814 / 19215  </div> </div>	<div style="text-align: center; border-bottom: 1px solid black;"> ENGINEERING DATA </div> <div style="text-align: center; border-bottom: 1px solid black;"> ESP SECTION </div> <p>CFM <input style="width: 100px;" type="text"/></p> <p>INT. STATIC PRESSURE <input style="width: 100px;" type="text"/> "W.G.</p> <p>MIN. WATER TEMP. 140°F MAX. WATER TEMP. 180°F MIN. WATER PRESSURE 30 PSIG MAX. WATER PRESSURE 80 PSIG</p> <p>ESP POWER PACK CIRCUIT:</p> <table style="width: 100%; border-collapse: collapse;"> <tr> <th style="text-align: center;">VOLTS</th> <th style="text-align: center;">PHASE</th> <th style="text-align: center;">HERTZ</th> <th style="text-align: center;">AMPS</th> <th style="text-align: center;">WATTS</th> </tr> <tr> <td style="text-align: center;"><input style="width: 50px;" type="text"/></td> <td style="text-align: center;"><input style="width: 50px; text-align: center;" type="text" value="1"/></td> <td style="text-align: center;"><input style="width: 50px;" type="text"/></td> <td style="text-align: center;"><input style="width: 50px;" type="text"/></td> <td style="text-align: center;"><input style="width: 50px;" type="text"/></td> </tr> </table> <p>MAX. FUSE SIZE <input style="width: 100px;" type="text"/> AMPS</p> <p>MAX. BREAKER SIZE <input style="width: 100px;" type="text"/> AMPS</p> <hr/> <div style="text-align: center;"> OPTIONAL FAN SECTION </div> <p>CFM <input style="width: 100px;" type="text"/></p> <p>TOTAL STATIC PRESSURE <input style="width: 100px;" type="text"/> "W.G.</p> <p>EXHAUST FAN POWER CIRCUIT:</p> <table style="width: 100%; border-collapse: collapse;"> <tr> <th style="text-align: center;">VOLTS</th> <th style="text-align: center;">PHASE</th> <th style="text-align: center;">HERTZ</th> <th style="text-align: center;">AMPS</th> </tr> <tr> <td style="text-align: center;"><input style="width: 50px;" type="text"/></td> <td style="text-align: center;"><input style="width: 50px;" type="text"/></td> <td style="text-align: center;"><input style="width: 50px;" type="text"/></td> <td style="text-align: center;"><input style="width: 50px;" type="text"/> FLA</td> </tr> </table> <p>MIN. CIRCUIT AMPACITY <input style="width: 100px;" type="text"/></p> <p>MAX. FUSE SIZE <input style="width: 100px;" type="text"/> AMPS</p> <p>MAX. BREAKER SIZE <input style="width: 100px;" type="text"/> AMPS</p> <p style="text-align: center;">-CAUTION-</p> <p style="font-size: small;">THE ELECTROSTATIC CELLS SHOULD BE INSPECTED FREQUENTLY TO ENSURE THAT COLLECTED GREASE IS BEING REMOVED BY THE WASHING SYSTEM. REFER TO THE TECHNICAL MANUAL FOR SPECIFIC INSTRUCTIONS. CELL WEIGHS MORE THAN 45 POUNDS. HANDLE WITH CARE WHEN REMOVING FOR CLEANING AND SERVICING.</p>	VOLTS	PHASE	HERTZ	AMPS	WATTS	<input style="width: 50px;" type="text"/>	<input style="width: 50px; text-align: center;" type="text" value="1"/>	<input style="width: 50px;" type="text"/>	<input style="width: 50px;" type="text"/>	<input style="width: 50px;" type="text"/>	VOLTS	PHASE	HERTZ	AMPS	<input style="width: 50px;" type="text"/>	<input style="width: 50px;" type="text"/>	<input style="width: 50px;" type="text"/>	<input style="width: 50px;" type="text"/> FLA
VOLTS	PHASE	HERTZ	AMPS	WATTS															
<input style="width: 50px;" type="text"/>	<input style="width: 50px; text-align: center;" type="text" value="1"/>	<input style="width: 50px;" type="text"/>	<input style="width: 50px;" type="text"/>	<input style="width: 50px;" type="text"/>															
VOLTS	PHASE	HERTZ	AMPS																
<input style="width: 50px;" type="text"/>	<input style="width: 50px;" type="text"/>	<input style="width: 50px;" type="text"/>	<input style="width: 50px;" type="text"/> FLA																

Figure D-1-1
Nameplate

This Page Intentionally Left Blank

This Page Intentionally Left Blank

Pre Start-Up Check

Overview

As one of the benefits of purchasing a Gaylord ClearAir Unit is a complete Start-Up Inspection is performed by a Gaylord Authorized Representative or a Gaylord Certified Service Agency. These tests must be conducted prior to use by the operator. Typically at the time the Start-Up Inspection is performed, the operation and general maintenance of the Gaylord equipment is demonstrated and described to the operating personnel. It is the responsibility of the Gaylord Authorized Representative or Agency to coordinate the date of Start-Up with any personnel such as the GC, owner, owner's rep, Fire Marshall, fire protection contractor, air balancer etc., required to witness the Start-Up.

Pre Start-Up Requirements

Before a Gaylord Start-Up can be performed, the responsible contractor or dealer must have the ClearAir Unit installed and operating. The following is a check list of items that must be completed prior to a Start-Up being conducted.

Pre Start-Up Check List

- ___ ClearAir Unit is installed as per Gaylord Submittal Drawings.
- ___ Check to ensure that duct work is a minimum 16 GA steel or 18 GA stainless steel, all welded and continuously welded to the connection at the ClearAir Unit.
- ___ If the unit was shipped in sections, check for proper assembly of the unit as shown on pages B-1 and B-2.
- ___ Check the fan section to ensure that the shipping straps have been removed and the fan isolators have been unscrewed as per the instructions on page 6-1.
- ___ Check to see that all required electrical and plumbing connections between the Gaylord Command Center, Wash Control Cabinets and the ClearAir Unit are completed per plans and operational.
- ___ Check to see that all pre-filters and ESP Cells are installed.
- ___ If a media bed odor control system was provided, make sure that it was installed per the instructions on page B-1.
- ___ If a spray odor control system was provided, locate the 5 gallon pail of GS-710 provided in the spray odor control cabinet. Remove the lid and install the pickup tube and level sensor.
- ___ Start exhaust fan and check for proper fan rotation. **Warning: A fan running backwards will overheat the motor and can cause bearing failure or other serious damage and will void the Warranty.**

ClearAir Start-Up Inspection and Test Report – Page 1

For RSPC-ESP-OW Series

Facility Name _____ Address _____ City _____ State ____ Zip _____ Facility Contact Name _____ Facility Contact Phone # _____ Facility E-Mail _____ This Report is for ClearAir Unit # _____	Gaylord Representative Performing Start-Up _____ Company Name _____ Date of Start-Up _____ Gaylord File Number _____
---	--

ClearAir Model Number _____

Preliminary Checklist

ESP Section

1. ___ Open all access doors and panels including electrical disconnect panel.
2. ___ Complete a thorough inspection of the unit for any shipping, handling, or installation damages, and if any make note under Comments.
3. ___ Verify that all debris screens, moisture separators, after filters are in place. See submittal drawings for details.
4. ___ Verify that all ESP Cells are in place and the high voltage wiring is properly connected.
5. ___ Verify that hot water piping is connected to the hot water inlet.
6. ___ Verify that the drain line is connected and that its size is equal to or greater than the outlet on the unit drain outlet.
7. ___ Verify that the spare fuses are provided inside the electric disconnect panel.

If Equipped with Media Bed Odor Control

8. ___ Verify that all panels or loose fill modules are in place. If loose, fill modules and verify that they are filled with media.
9. ___ Verify that the Odor Control Media Monitoring Tube is in place.

If Equipped with Spray Odor Control

10. ___ Verify that the container of spray odor chemical, Gaylord Formula GS-710, is in the spray odor cabinet and that the pickup tube is inserted into the container.

If Equipped with an Exhaust Fan

11. ___ Verify that the wall insulation is secure and has not loosened in shipment.
12. ___ Verify that all shipping tie downs, bolts and braces have been removed.
13. ___ Verify that the fan floats freely on the spring isolators and the fan wheel turns freely by rotating the pulleys.
14. ___ Verify that the exhaust discharge is not obstructed and not facing any structure.
15. ___ If a duct system is connected to the exhaust discharge, verify that the connection is continuously welded.

ClearAir Start-Up Inspection and Test Report – Page 2

Operational Check List

ESP Section

1. ___ Close and latch all access doors and panels.
2. ___ Verify that all circuit breakers are on and power is supplied to the ClearAir Unit.
3. ___ Turn the Disconnect Switch on the Main Electrical Panel to the on position.
4. ___ Push the Start Fan button the Command Center to energize the ESP Cell and exhaust fan.
 - a) Exhaust Fan started. ___ Yes ___ No.
 - b) Green ESP Cell status light on. ___ Yes ___ No.

Odor Control Section – Spray Odor Only

1. Verify that the Spray Odor Control pump came on. ___ Yes ___ No.
2. Verify that both timers are set to 15 seconds. ___ Yes. This may need to be adjusted to maximize the spray odor effectiveness. Decreasing the delay or increasing the spraying time will improve the effectiveness of the spray odor. Increasing the delay of decreasing the spray time will reduce the effectiveness.

Wash System

1. Push the Stop Fan button on the Command Center and check the following:
 - a) Exhaust Fan shut off. ___ Yes ___ No.
 - b) Water turned on. ___ Yes ___ No.
 - c) Oscillating motor operating. ___ Yes ___ No.
 - d) Length of Wash Cycle _____ Minutes.
 - e) Length of Delay _____ Minutes.
 - f) Length of Rinse Cycle _____ Minutes.
 - g) Water flow pressure at the ClearAir unit _____ PSI.
 - h) Water temperature _____ Degrees F.
 - i) Any water leaks ___ Yes ___ No. If yes make note in the Comment section.
 - j) Draining properly ___ Yes ___ No.
 - k) Brand of detergent used. _____
 - l) Number of spare Cells. _____
 - m) Number of Soak Tanks _____
 - n) Location of spare ESP Cells and Soak Tanks. _____

Limited Warranty

For ClearAir Series Pollution Control Units

Effective November 15, 2013

The Gaylord ClearAir Unit and component parts furnished with the ClearAir Unit are warranted to be free from defects of material and workmanship under normal use when installed, operated and serviced in accordance with factory recommendation. Aluminum, rubber and synthetic rubber parts such as "O" rings, diaphragms, poppet check, and gaskets are perishable when caustic cleaning solutions are used and, therefore, are not covered by this warranty.

The Manufacturer's obligation under this warranty and any warranties implied by law shall be limited to repairing or replacing at its option any part of said equipment when either Gaylord Industries, or the Licensed Gaylord Manufacturer's examination shall disclose to its satisfaction to be thus defective, for a period of one (1) year from the date of beneficial use, or eighteen months from date of shipment, whichever occurs first, provided proper and acceptable evidence of such is recorded at the factory. GAYLORD INDUSTRIES AND THE LICENSED GAYLORD MANUFACTURER SHALL NOT BE RESPONSIBLE FOR INCIDENTAL OR CONSEQUENTIAL DAMAGES RESULTING FROM A BREACH OF THIS WARRANTY.

Replacement parts furnished under this warranty shall be F.O.B. Gaylord Industries, Tualatin, Oregon U.S.A. The owner shall pay the necessary freight delivery charges, and necessary labor for removal and installation of parts, and any tariffs, duties or all taxes.

Component parts not manufactured by Gaylord Industries such as electrical switches, relays, solenoid coils, etc., shall be warranted under the terms and conditions of the warranty that is published by the manufacturer of said component parts.

This warranty does not cover routine maintenance and inspection of the cleaning system as spelled out in The Gaylord Ventilator Technical Manual. This warranty also does not cover malfunctions or improper operation caused by fluctuating electrical power or power surges.

This is the sole warranty with respect to the aforesaid items. NEITHER GAYLORD INDUSTRIES OR THE GAYLORD LICENSED MANUFACTURER OR ANY OTHER PARTY MAKES ANY OTHER WARRANTY OF ANY KIND WHATSOEVER, EXPRESSED OR IMPLIED, AND ALL IMPLIED WARRANTIES OF MERCHANTABILITY AND FITNESS FOR A PARTICULAR PURPOSE WHICH EXCEED THE AFORESAID OBLIGATIONS ARE HEREBY DISCLAIMED AND EXCLUDED FROM THIS AGREEMENT.

Specific Items Not Covered By This Warranty

1. Fan belts if equipped with an exhaust fan.
2. Pre filters, final filters, and odor control media if equipped with odor control.
3. Malfunction caused by fluctuating electrical or power surges or improper installation.

Service and Warranty Policies

1. No warranty work shall be performed on the product without a Purchase Order from Gaylord Industries, if financial reimbursement is to be requested.
2. No warranty shall be provided on equipment that has been started up and in operation for more the 90 days unless, a product maintenance schedule has been created and performed per the requirements of this technical manual.
3. Any, and all, wearable parts are not to be considered warranty items, regardless of installation date, unless previously authorized by the factory.



**WORLDWIDE SALES, MANUFACTURING AND SERVICE
FOR THE NAME AND LOCATION OF THE NEAREST
CERTIFIED SERVICE AGENCY, VISIT OUR WEB SITE:**

WWW.GAYLORDVENTILATION.COM

OR CONTACT US AT:

GAYLORD INDUSTRIES

10900 SW AVERY STREET
TUALATIN, OREGON 97062 U.S.A

Phone: 503-691-2010

1-800-547-9696

Fax: 503-692-6048

email: info@gaylordventilation.com

LOCAL SERVICE AGENCY