

Operations & Service Manual

EH-5 & 6



Giles Enterprises, Inc.

ISO 9001 Registered Company • Committed to Quality
2750 Gunter Park Drive West • Montgomery, AL 36109 USA
Phone: 334.272.1457 • Fax: 334.239.4117 • Website: www.gfse.com
Service Hotline (Toll Free): 800.554.4537 (USA & Canada Only)
Form No. 60073 (Revised: 08/25/11 - Rev. E)





LIMITED WARRANTY

- Subject to the terms and conditions of this Limited Warranty as herein stated, all Giles Enterprises, Inc., Foodservice Equipment and parts purchased new from an authorized Giles Enterprises, Inc., representative are warranted as to defects in material or workmanship for a period of 12 months from the date of installation, provided, however, that with regard to labor costs in connection with this warranty, see below. All installations must be made by a qualified installing agency in accordance with all applicable codes and/or regulations in the jurisdiction in which installed. Limited warranty coverage is extended to the original owner only and is void if the unit is resold.
- During the Limited Warranty period, Giles Enterprises, Inc. will replace or recondition, at its factory, any part or parts of this unit which Giles Enterprises, Inc. inspectors judge defective, provided the unit has been subjected to normal usage, properly installed, operated and serviced. This Limited Warranty does not cover cosmetic damage, and damage due to acts of God, accident, misuse, alteration, negligence, abuse of the Giles Foodservice Equipment or the use of unorthodox repair methods. All parts replaced under this Limited Warranty carry only the unexpired term of this Limited Warranty. Limited Warranty service may be furnished only by an authorized Giles Enterprises, Inc., representative.
- If Limited Warranty service is requested, Giles Enterprises, Inc., will send factory-authorized service representatives to repair, recondition, replace or inspect units of its manufacture with such labor being rendered without cost to owner for ninety (90) days from the date of installation. Otherwise, service, including labor and transportation charges or other expenses, in connection with the removal or installation of any part or parts supplied under this Limited Warranty, are specified on the original sales contract between the purchaser and the authorized Giles Enterprises, Inc., representative.
- Giles Enterprises, Inc. reserves the right to change or improve its equipment and parts in any way without obligation to alter such equipment or parts previously manufactured.
- Giles Enterprises, Inc. makes no further warranties, express or implied including implied warranties of merchantability or fitness for a particular purpose, and has no other obligation or liability not specifically stated herein.
- Repair or replacement as provided under this limited warranty is the exclusive remedy. Giles Enterprises, Inc., shall not be liable for any incidental or consequential damages for breach of any express or implied warranty on this product, except to the extent prohibited by applicable law. Any implied warranty of merchantability or fitness for a particular purpose on this product is limited in duration to the duration of this limited warranty.
- Used Giles Enterprises, Inc., Foodservice Equipment or parts or Giles Enterprises, Inc., Foodservice Equipment or parts not purchased from an authorized Giles Enterprises, Inc., representative, carry no warranties, express or implied.

Safety	v
Safety Overview	v
Specific Safety Precautions	vi
1. Introduction	1
1-1. Construction	1
1-2. Standard Features	1
1-3. Optional Features	1
1-4. Specifications	2
1-4.1 Overall Dimensions for EH-5	2
1-4.2 Overall Dimensions for EH-6	3
1-4.3 Regulatory Listings	4
1-4.4 Hood Weights	4
2. Installation	5
2.1 Unpacking	5
2.2 Location	6
2.3 Hood Mounting Detail	6
2.3.1 Hood Skirt Installation	7
2.4 Cooking Appliance limitations and clearances	8
2.4.1 Fryer limitations	8
2.4.2 Fryer clearances	8
2.4.3 Oven limitations	9
2.4.4 Oven clearances	9
2.4.5 Griddle limitations	10
2.4.6 Griddle clearances	10
2.4.7 Range limitations	11
2.4.8 Range clearances	11
2.5 Hood Electrical Requirements	12
2.5.1 Electrical Connections	12
2.5.2 Routing Power Wires	13
2.5.3 Hood and Appliance Interlock Diagram	13
2.6 Fire Suppression System Installation	14
2.6.1 Fire Suppression System Routing	14
2.6.2 Fire Suppression Fusible Links	15
2.6.3 Appliance Nozzles	15
2.6.4 Fire Extinguisher Nozzle Locations	16
2.6.5 General Maintenance	16
3. Overview	17
3.1 Control Panel	18
3.2 Filter Chamber and Exhaust	20
3.3 Accessories (Included)	22



4.	Operation & Filter Maintenance	25
4.1	Hood Operation	25
4.2	Filters and Filter Maintenance	25
4.2.1	Ventless Hood Filter Table	25
4.2.2	Baffle Filter Removal	26
4.2.3	Baffle Filter Installation	27
4.2.4	Baffle Filter Missing	27
4.2.5	Baffle Filter Cleaning	28
4.2.6	Pre-Filter Removal	28
4.2.7	Pre-Filter Installation	29
4.2.8	Pre-Filter Filter Missing	29
4.2.9	Pre-Filter Replacement	30
4.2.10	EAC Filter Removal	30
4.2.11	EAC Filter Installation	31
4.2.12	EAC Filter Status	32
4.2.13	EAC Filter Cleaning	32
4.2.14	Charcoal Filter Removal	33
4.2.15	Charcoal Filter Installation	34
4.2.16	Charcoal Filter Missing	34
4.2.17	Charcoal Filter Replacement	35
4.3	Filter Alarm Chart	35
5.	Hood Cleaning and Maintenance	36
5.1	Monthly Interlock Check	36
5.2	Quarterly Hood Cleaning	36
5.3.	Semi-Annual Fire Suppression System	37
5.4	Annual Fire Suppression System	37
5.5	12 Year Fire Suppression System	37
5.6	Maintenance & Service Log	38
6.	Troubleshooting	40
6.1	Troubleshooting Procedures	40
7.	Parts List	42
7.1	Parts Ordering and Service Information	42
7.2	Electrical Component Drawer EH-5 and EH-6	44
7.3	Front View - Doors and Panel removed	46
7.4	Baffle Filters and Switches	48
7.5	Doors and Front Panel	50

Safety

Safety Overview

The information contained in this manual has been prepared to aid in learning the proper procedures for installing, operating and servicing this unit.

Throughout this manual, safety precautions are identified through the use of the safety alert symbol and three signal words: **DANGER, WARNING**, and **CAUTION**. All safety alert information precedes the step(s) to which it applies. Suggested, recommended, or other noteworthy information is identified through the use of **NOTES**. Additionally, certain words are used to indicate a specific meaning or to add emphasis.

The following words are used as indicated throughout the manual:

Shall: understood to be mandatory.

Should: understood to be advisory.

May: understood to be permissive.

Will: indicates a future event/condition to occur.

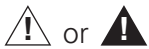

(Safety Alert Symbol)

Used in conjunction with signal words (**DANGER, WARNING**, or **CAUTION**) as alerts to potential personal injury hazards, immediately preceding precautionary measures that pertain to subsequent step(s). Obey all safety messages that follow this symbol to avoid possible injury or death. Failure to adhere to safety precautions identified by the safety alert symbol may also void the warranty.

DANGER

- Indicates an imminently hazardous situation which, if not avoided, will result in death or serious injury. Use of this is limited to the most extreme situations.

WARNING

- Indicates a potentially hazardous situation which, if not avoided, could result in death or serious injury.

CAUTION

- Indicates a potentially hazardous situation which, if not avoided, may result in minor or moderate injury. Also used to alert against unsafe practices.

CAUTION

- When used without the safety alert symbol, **CAUTION** indicates a potentially hazardous situation which, if not avoided, may result in equipment/property damage, and void the warranty.

NOTE:

- Identifies suggested, recommended, or other noteworthy information.

Specific Safety Precautions

For your safety, please observe the following precautions when operating or servicing your Environmental Hood, Model EH-5 or EH-6. Read the following important safety information to avoid personal injury and/or damage to the equipment.

DANGER

- Always disconnect the source of the main power before removing the service entrance box cover.
- Failure to ensure the Power switch is in the “OFF” position during servicing and when replacing filters could result in equipment damage, electrical shock and/or personal injury.
- Failure to comply with these **DANGER** notices will result in death or serious injury, equipment/property damage, and void the warranty.

WARNING

- **DO NOT** use or store flammable liquids or items that produce flammable vapors, in the vicinity of this or any other appliance!
- Consult a qualified electrician to ensure all electrical specifications have been met and the unit is properly grounded.
- Before installing or servicing this equipment, read the contents of this manual thoroughly.
- Improper installation, adjustment, alteration, service or maintenance could result in death or serious injury, equipment or property damage, and void the warranty.
- Failure to comply with these **WARNING** notices could result in death or serious injury and equipment or property damage.

CAUTION

- Exercise care when lifting or moving the unit. Refer to **Section 1-4.4, Hood Weights**.
- Exercise care when removing the wooden crating from around the unit.

CAUTION

- **DO NOT** operate the unit unless you fully understand the components and their intended function.
- Be careful not to bend the fins or break the ionizer wires on the EAC (Electrostatic Air Cleaner), as this will prevent it from working properly and will possibly shut down power to the appliance being used with the hood.
- Failure to comply with these **CAUTION** notices may result in minor or moderate injury, equipment or property damage, and void the warranty.

CAUTION

- The electronic components of the Control Panel are impact-sensitive. Exercise care around the Control Panel to maintain proper operation.
- Do not try to dry the EAC either by running the hood to air dry or by operating an appliance below to heat dry. This could potentially damage the EAC causing improper operation and voiding the warranty.
- When cleaning:
 - **DO NOT** steam clean.
 - **DO NOT** use products containing chlorine.
 - **DO NOT** use abrasive products, steel wool or scouring pads.
- Failure to comply with these **CAUTION** notices may result in equipment or property damage and void the warranty.

NOTE:

- Upon arrival, if the palletized unit shows any signs of damaged, immediately inspect the Hood and all other components contained on the pallet, and notify the freight company of any damage to the unit.
- To aid electricians and technicians, an electrical wiring diagram is contained in this manual. Refer to the wiring diagram during installation or servicing.
- Comply with all appropriate state and/or local health regulations regarding the cleaning and sanitation of equipment.
- For difficult areas with excessive particulate build up, a mild bio-degradable non-toxic degreaser (such as Clear Magic or Simple Green) may be used.
- Always ensure the unit is electrically grounded and installed in accordance with local codes, or in the absence of local codes, in accordance with the National Electrical Code ANSI/NFPA No. 70-1984.



NOTES:

1. Introduction

Congratulations on the purchase of your new Giles Environmental Hood System (EH-5 or EH-6) manufactured by Giles Enterprises, Inc., Montgomery, Alabama (USA). Standard mounting for this hood is suspension from the ceiling. Proper care and maintenance will ensure years of trouble-free service.

To help protect your investment in this equipment, we recommend taking a few moments to familiarize yourself with the installation, operational, cleaning, and maintenance procedures contained in this manual. Please read this manual before installing and operating the Hood. Adherence to these recommended procedures minimizes the potential for costly future "down-time" or equipment repairs. Please retain this manual for future reference.

1.1 Construction

The Environmental Hood System exterior and interior is constructed of stainless steel.

1.2 Standard Features

Control Panel

- Control panel LED indicators display the status of the EAC Filters (left & right).
- Missing Filter Light indicates if one, or more, of the two (2) Baffle Filters, Pre-Filters, or Charcoal Filters is missing or improperly installed.

Filters

- Baffle Filters capture large grease particulate and drain condensate into the grease gutter to be captured in the Drip Cup.
- Pre-Filters capture smaller grease particulate and moisture.
- Electronic Air Cleaners (EAC) capture smoke & other fine contaminants in the air stream.
- Activated Charcoal Filters help eliminate cooking odors from the air stream.

1.3 Optional Features

Inter-Locking Start System (ILS)

- Inter-Locking Start System (ILS) - Should there be a power interruption to the hood, this system will not allow the Hood and the served Appliance(s) to restart without the attendance of an operator. This system is required by code in some cities and/or states. Please consult with your local code officials to see if this option is required.

1.4 Specifications

1.4.1 Overall Dimensions - EH-5

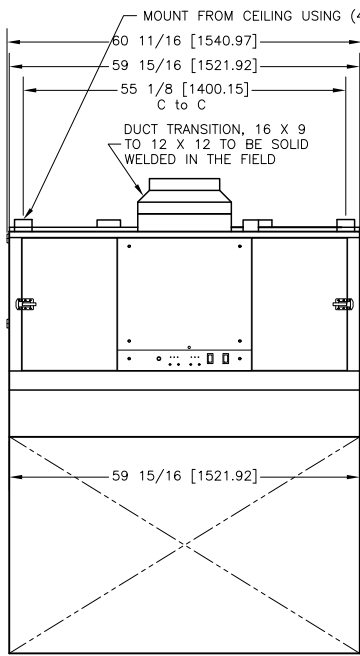

FRONT VIEW

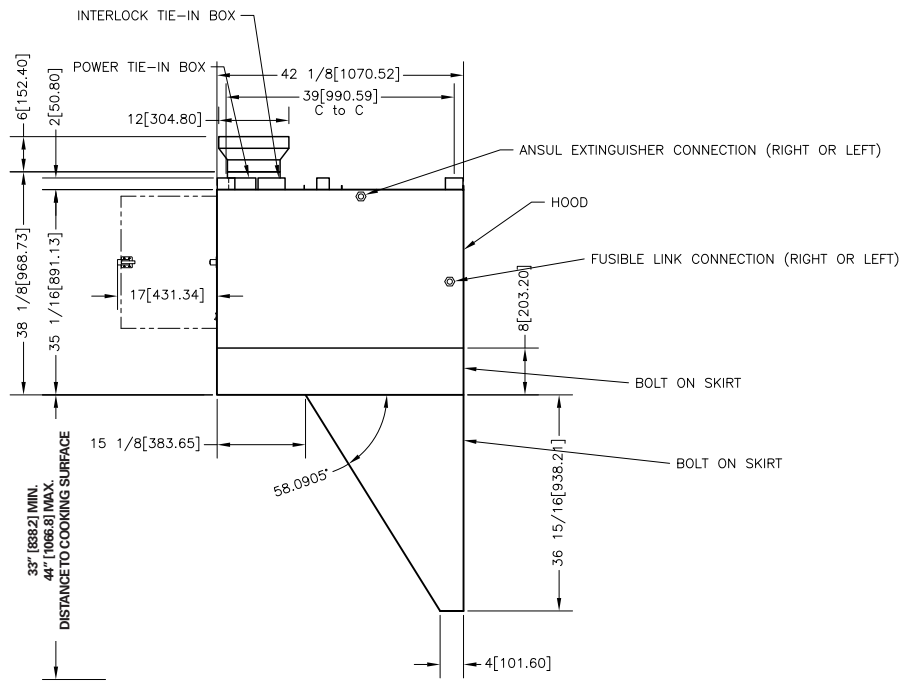

SIDE VIEW

1.4.2. Overall Dimensions for EH-6

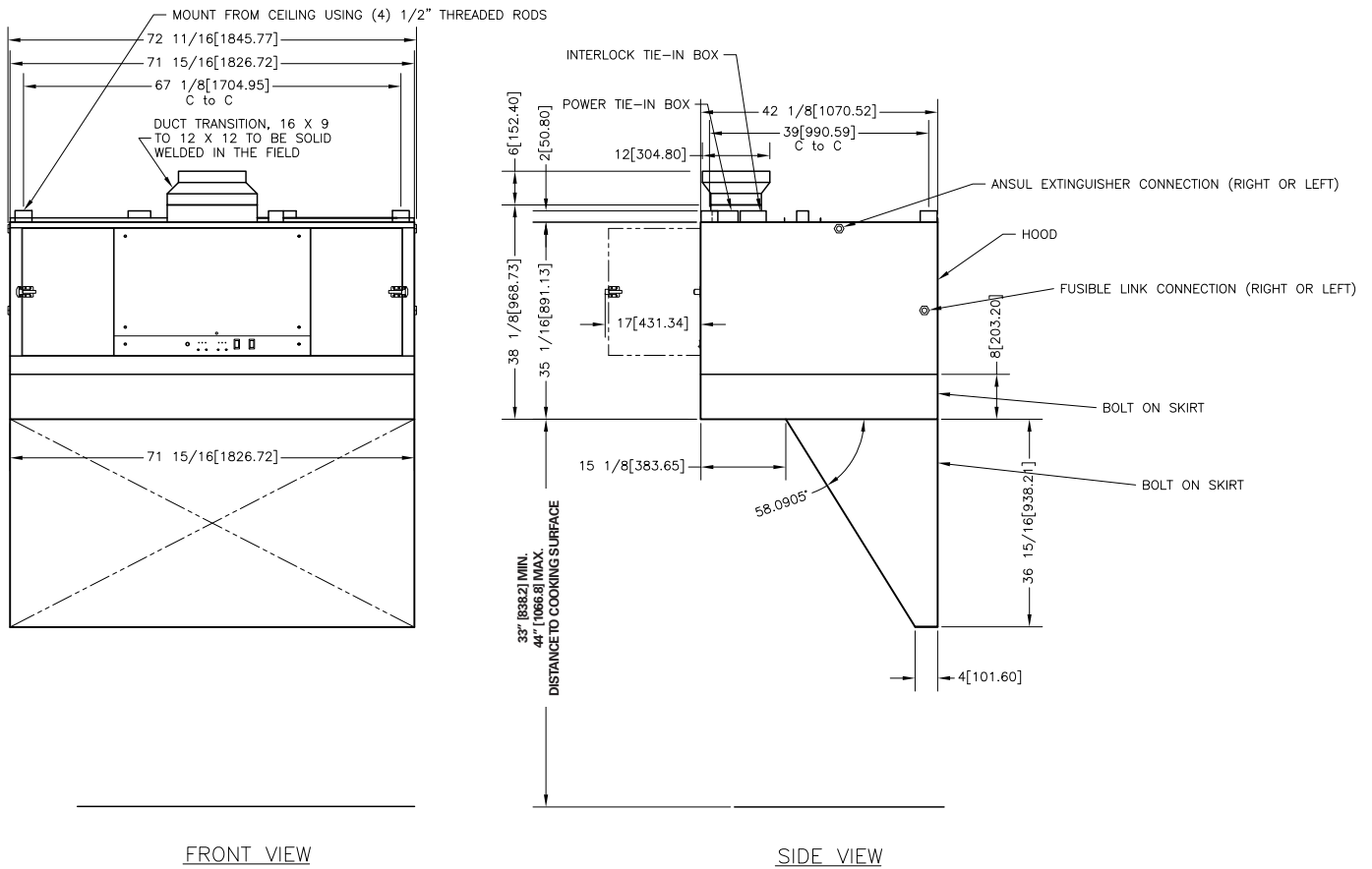



1.4.3 Regulatory Listings

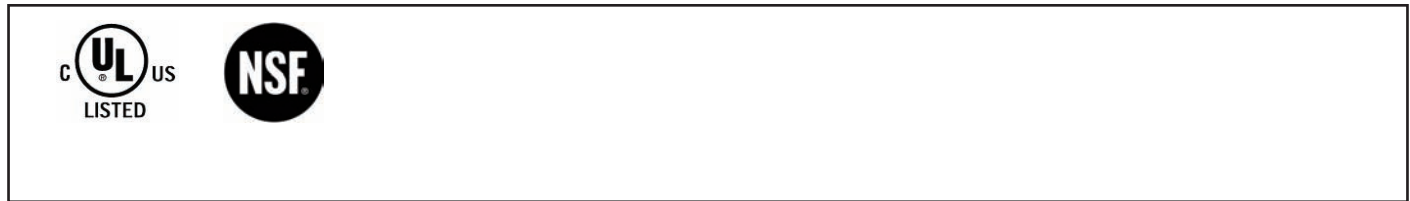

1.4.4 Hood Weights

Hood	Crated Weight	Uncrated Weight
EH-5	664 lbs [302 kg]	464 lbs [211 kg]
EH-6	733 lbs [333 kg]	553 lbs [251 kg]

2. Installation

This section provides a summary of procedures necessary to install your new EH-5 or EH-6 Environmental Hood. Before installing or servicing this equipment, please read the contents of this manual thoroughly. Following these procedures will help ensure a safe and proper installation.

NOTE:

The Giles Environmental Hood is a conventional type ventilation hood that must be connected by ductwork to an appropriately sized exhaust fan that discharges to the outside atmosphere. Prior to beginning installation, it is recommended to consult a qualified ventilation specialist to assess the site and determine fan and ductwork requirements, as well as address any local regulatory permit requirements. If desired, a "Fan Quotation Form" is available from Giles Services to help guide customers through this process. **It is the sole responsibility of the purchaser to supply the appropriate exhaust fan, ductwork, installation, all permits, and any consulting services deemed necessary, as this is NOT included with the hood purchase.**

2.1 Unpacking

The Hood should arrive palletized with a wooden protective frame, wrapped in machine applied stretch-wrap, and secured by means of high-tensile plastic strapping. The Backsplash, two (2) Side Skirts and Baffle Filters should be packed on top of Hood. Perform the following steps to unpack the unit.

1. Position the palletized unit in an area that has sufficient space for unpacking.

!! IMPORTANT NOTE:

- If the palletized unit shows any signs of damage, immediately inspect the equipment and other packed components, and notify the freight company of any and all damages. **Giles is not responsible for shipping damage claims.**

2. Cut and remove stretch-wrap and all strapping.
3. Use a hammer and pry-bar to remove the wooden framing from around the unit.
4. Carefully remove and set aside Skirts, Backsplash, Baffle Filters and envelope containing hardware and silicone sealant.

CAUTION

- Use suitable equipment to lift the hood and carefully move it away from the pallet ... refer to **Section 1.4.4, Hood Weights**. Take precautions not to damage to the hood's bottom skirting. If possible, it is advisable to rig and lift the hood from the topside, utilizing the hood's hanging brackets.
- Exercise care when removing the wooden framing from around the unit.
- Failure to comply with these **CAUTION** notices may result in minor or moderate injury, equipment or property damage, and void the warranty.

2.2 Location



• DO NOT MODIFY, ALTER OR ADD ATTACHMENTS TO THIS EQUIPMENT

1. Ensure intended mounting site is sound and that roof or ceiling structure is capable of supporting the hood's weight; refer to **Section 1.4.4, Hood Weights.**

2.3 Hood Mounting Detail

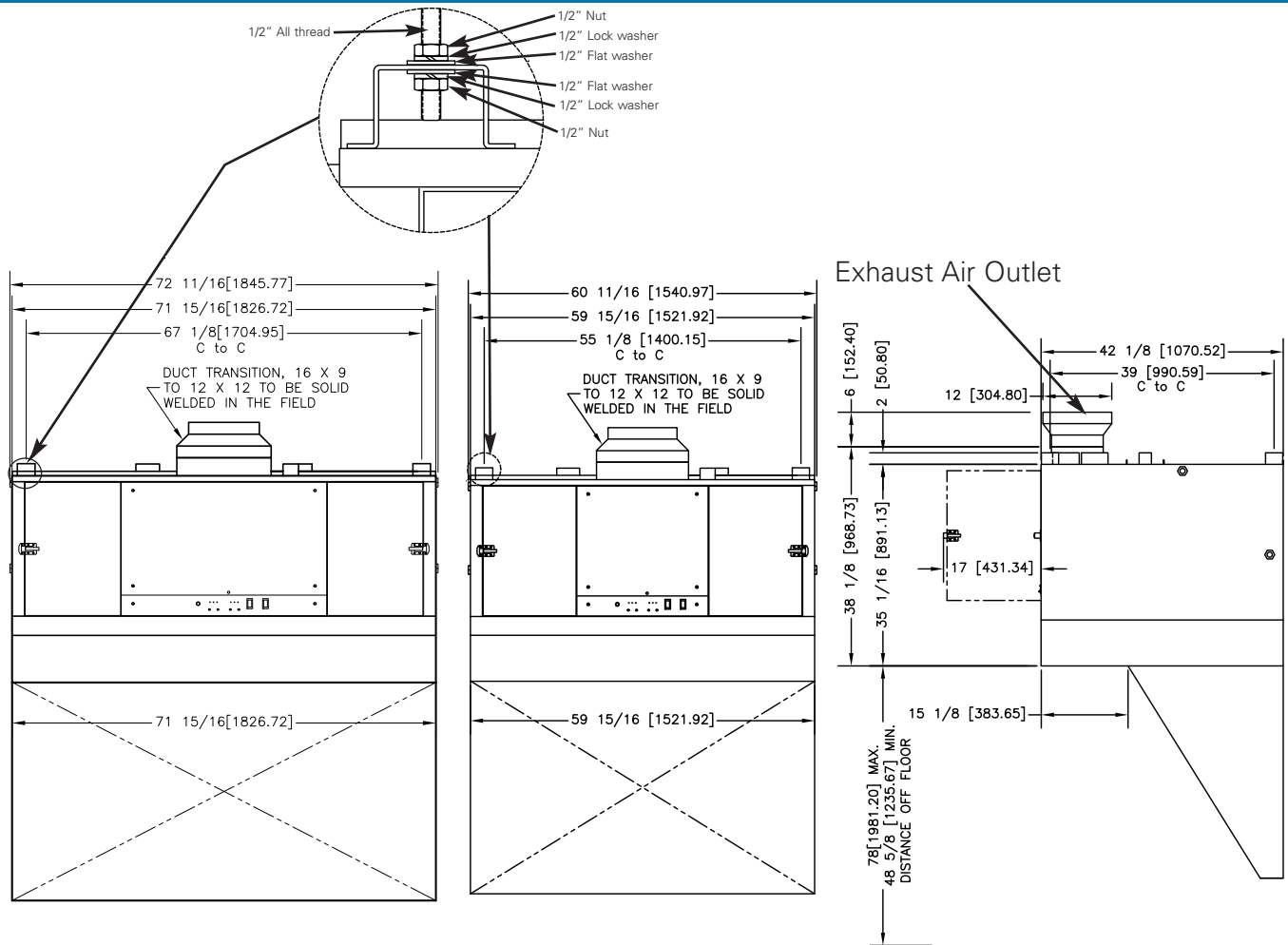

1. Ensure the hood is level, left to right and front to back.
2. Ensure all mounting fasteners are secure.

2.3.1 Hood Skirt Installation

NOTE:

- All hood Skirts MUST be installed to ensure proper and effective capture of vapors.

1. Apply a bead of Hi-Temp Silicone (tube enclosed) to the top flanges of both Side Skirts.
2. Attach Left and Right Side Skirts to hood with enclosed fasteners (do not tighten completely).
3. Apply a bead of the Hi-Temp Silicone to the top flange of the Rear Skirt.
4. Attach Rear Skirt to hood with enclosed fasteners (do not tighten completely) .
5. Fasten Left and Right Skirts to Rear Skirt.
6. Completely tighten all fasteners and wipe any excess silicone from the assembled Skirt.

NOTE: Peel all protective film from parts before assembling.

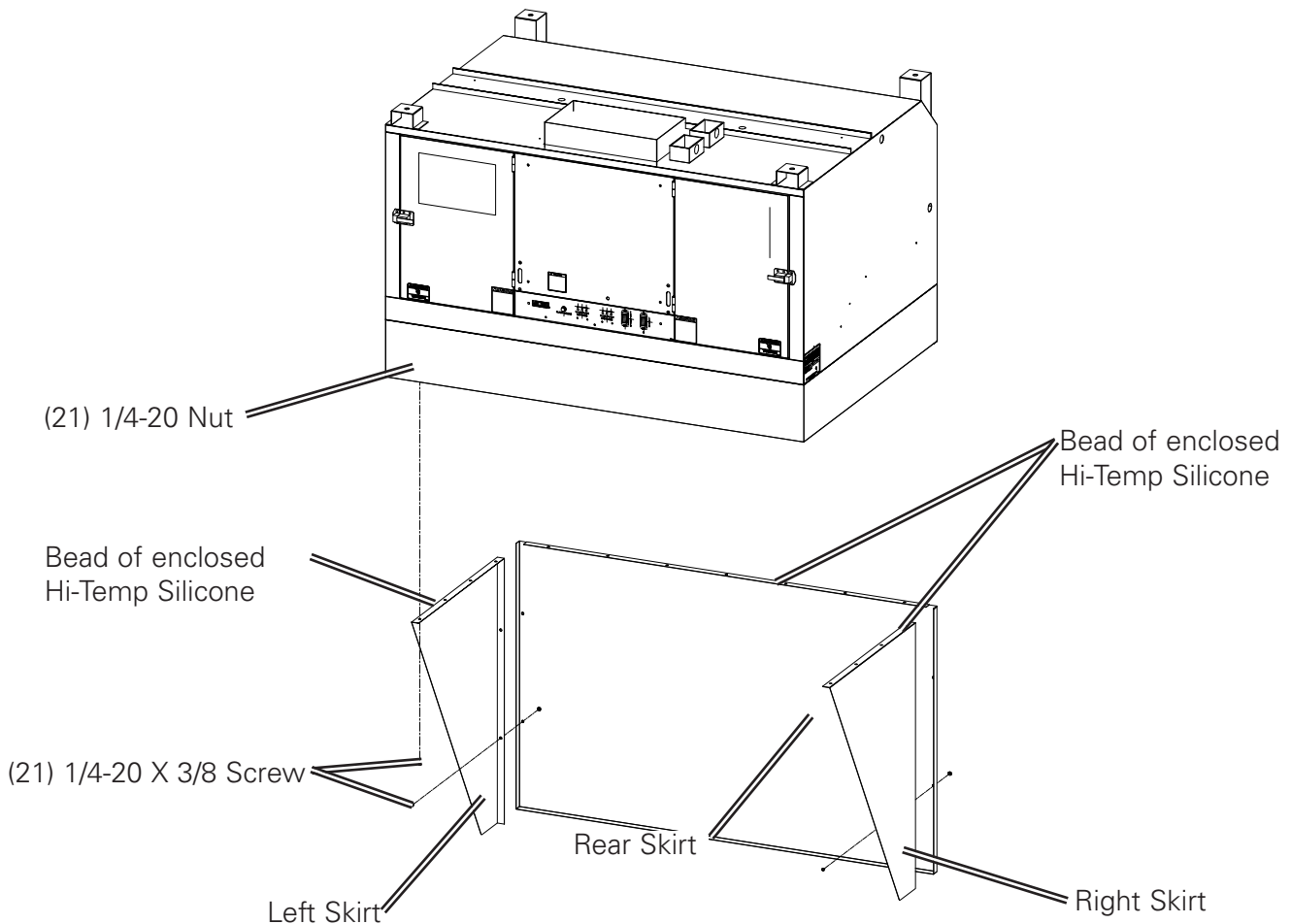

2.4 Cooking Appliance limitations and clearances

Hood	Max. Temp.	Recommended Exhaust Airflow CFM	Side Overhang	Front Overhang
EH-5	400	775/1107@1.25 wc	6 In.	12 In.
EH-6	400	846/1208@1.25 wc	6 In.	12 In.

2.4.1 Griddle Limitations

Hood	Max. Temp.	Max. KW Input	Max. Cooking Surface
EH-5	400	25	48 x 26
EH-6	400	25	60 x 26

2.4.2 Griddle Clearances

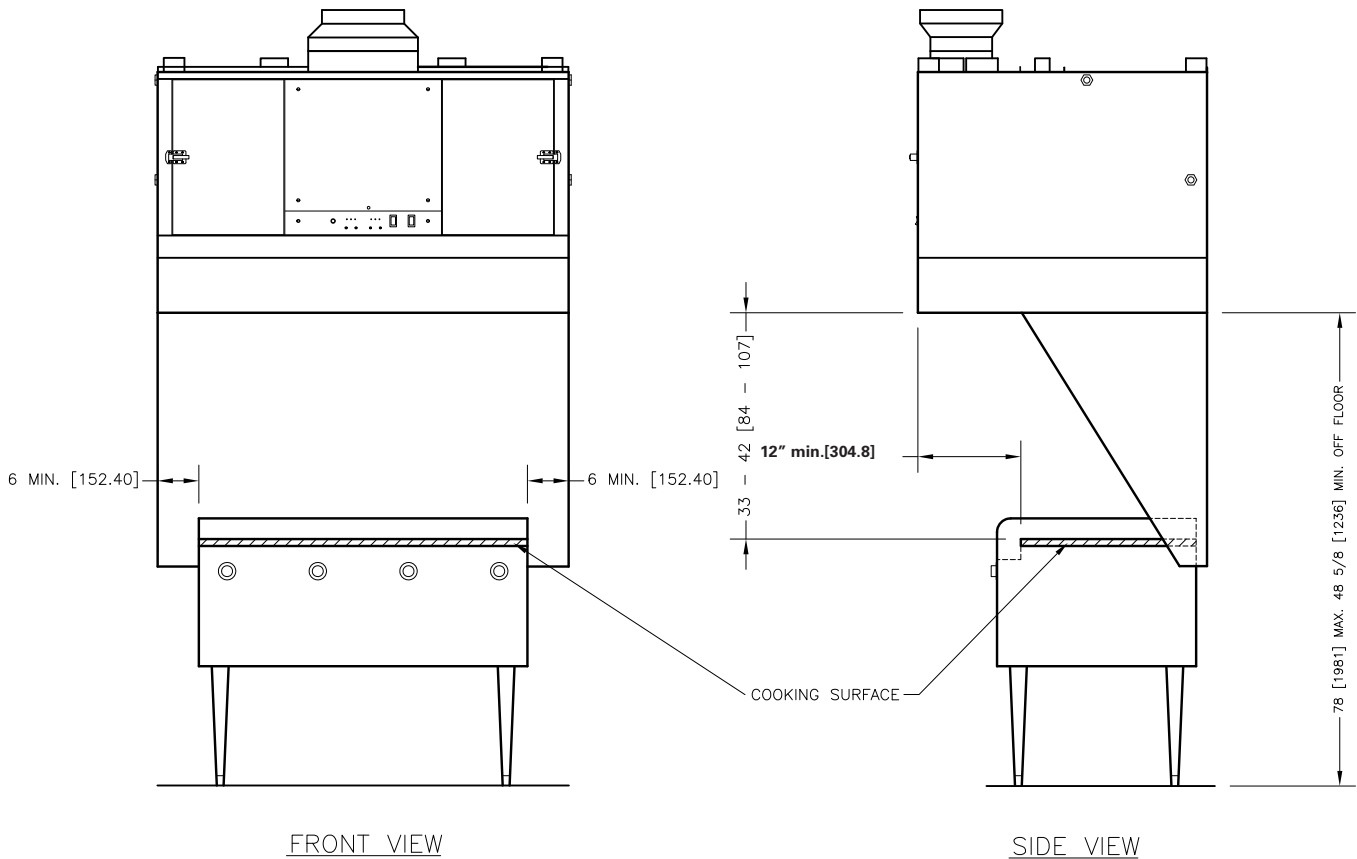

Inches [Millimeters]

2.4.3 Range limitations

Hood	Max. Temp.	Max. kW Input	Max Burners
EH-5	400	25	8
EH-6	400	25	8

2.4.4 Range clearances

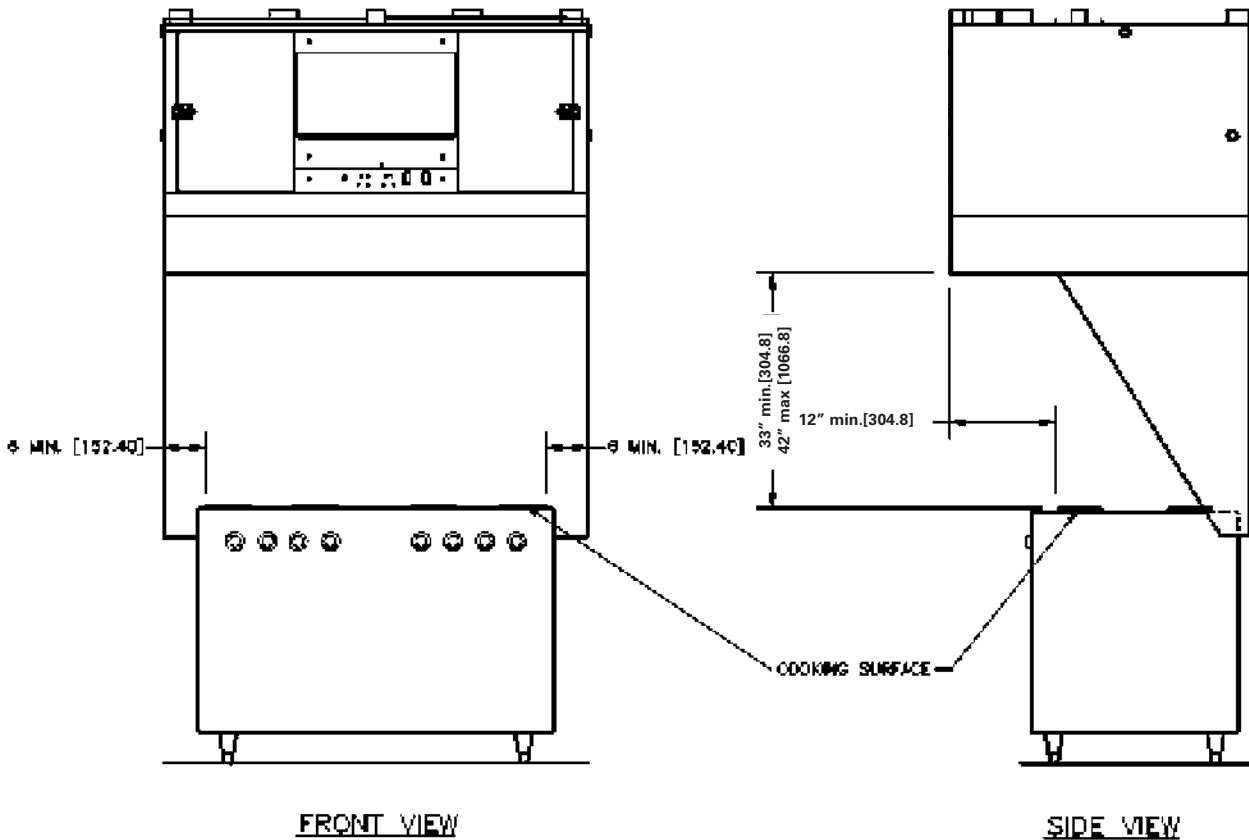

Inches [Millimeters]

2.4.5 Oven limitations

Hood	Max. Temp.	Max. kW Input (Total all Ovens)
EH-5	500	55
EH-6	500	55

2.4.6 Oven clearances

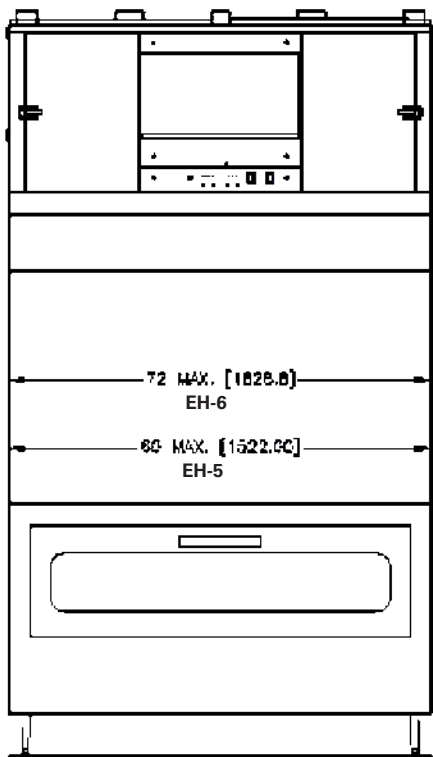

FRONT VIEW

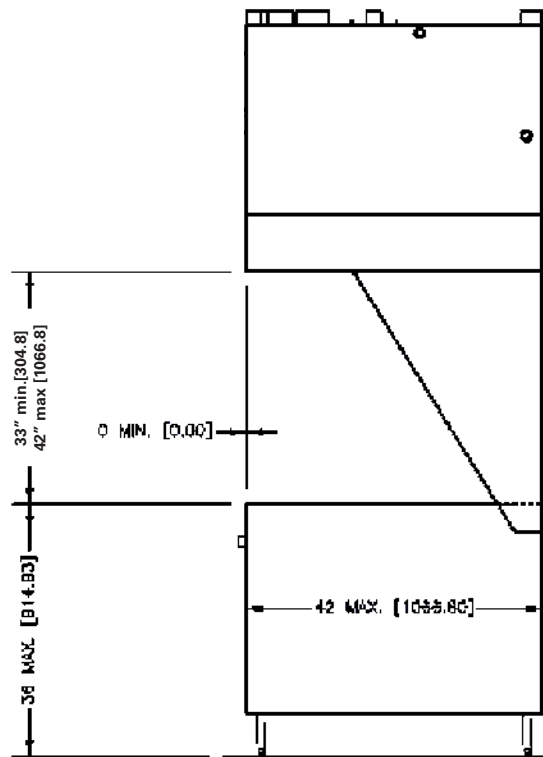

SIDE VIEW

Inches [Millimeters]

2.4.7 Fryer limitations

Hood	Max. Temp.	Max. kW Input	Max. Shortening Capacity	Max Cooking Surface (per Fryer)	Max Cooking Surface (Total all Fryers)
EH-5	400	20	10.5	380 Sq. In.	760 Sq. In.
EH-6	400	20	10.5	380 Sq. In.	760 Sq. In.

2.4.8 Fryer clearances

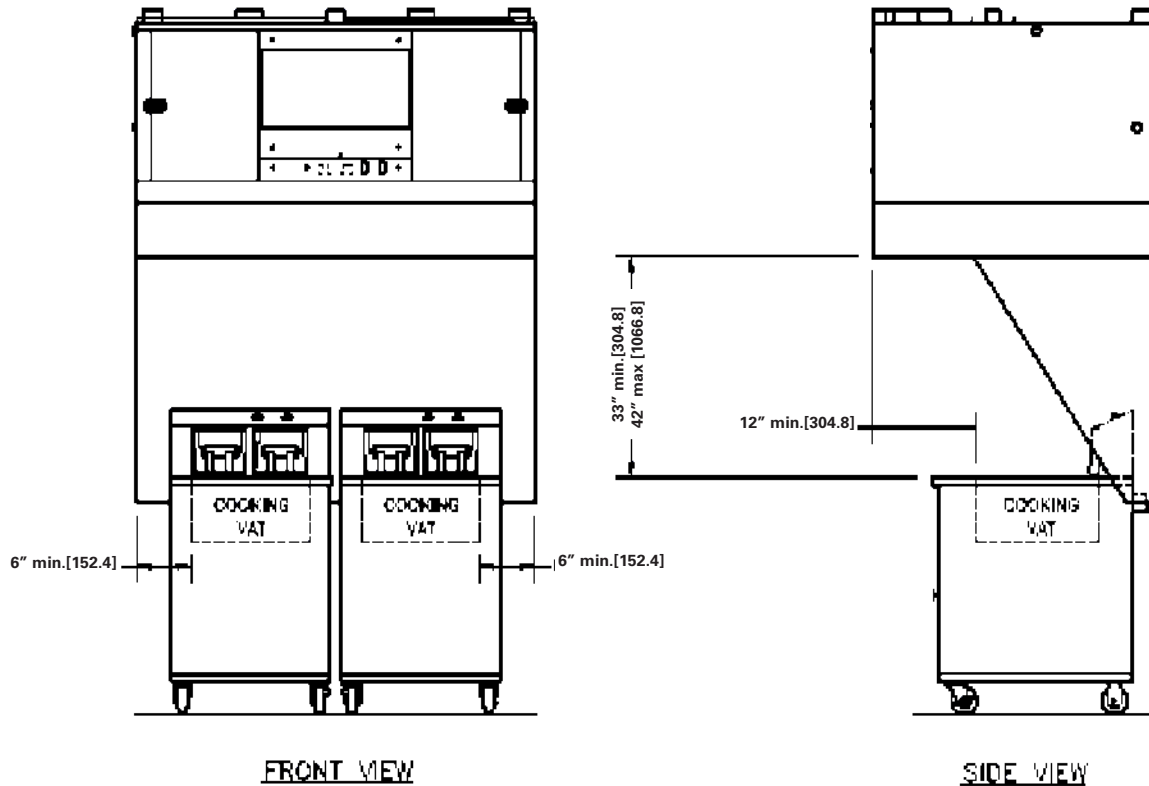

Inches [Millimeters]

2.5 Hood Electrical Requirements

WARNING

- Consult a qualified electrician to ensure all electrical specifications have been met and that the unit is properly wired and grounded.
- Improper installation, adjustment, alteration, service or maintenance could result in death or serious injury, equipment/property damage, and void the warranty.

Hood Electrical Requirements					
Unit	Voltage	Hz	Phase	Amps	Breaker
EH-5	208	60	1	15	20
EH-5	240	60	1	15	20
EH-6	208	60	1	15	20
EH-6	240	60	1	15	20

2.5.1 Mechanical & Electrical Connections

Mechanical:

1. Weld a 9"x16" to 12"x12" duct transition piece to the air discharge duct of the Environmental Hood (***customer supplied**).
2. Install and connect ductwork between hood and an appropriately sized exhaust fan, which discharges to the outside atmosphere (***customer supplied fan, ductwork, and installation**).
3. Install exhaust ductwork system in accordance with applicable local codes.
4. Wire fan motor into hood at the junction box on topside of hood.
5. Install an appropriate pressure pick-up in the duct system and connect it to the pressure switch with 1/4" silicone tubing. Adjustable pressure switch is located in the component tray behind Control Panel.

Electrical:

1. Install appropriate Circuit Breaker in Main Breaker Box (**refer to Section 2.5**).
2. Connect appropriate size wire from hood to the main breaker.
3. Re-install Service Panel.
4. Turn Main Breaker on.
5. Press the Hood power switch to the **ON** position. If ILS equipped, press and hold the "Push to Start" button for 5 secs after power is on.

2.5.2 Routing Power Wires

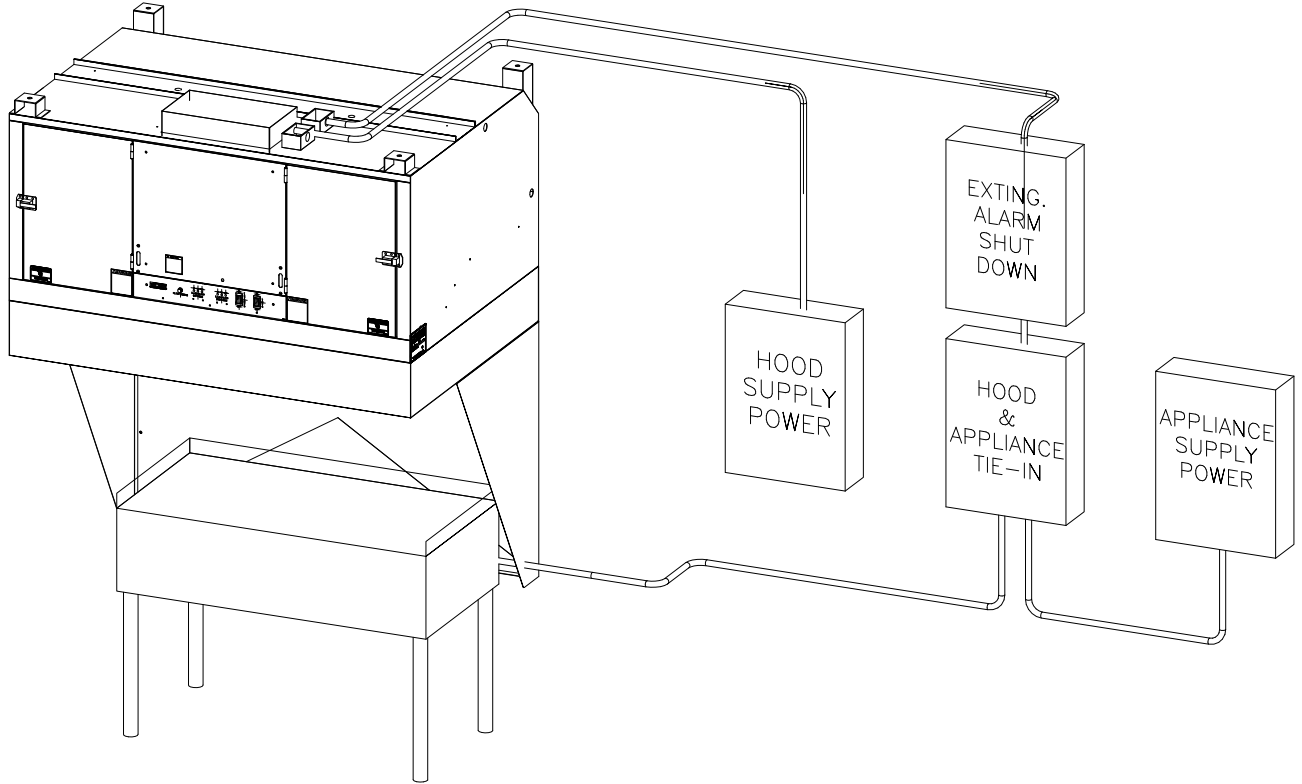

2.5.3 Hood and Appliance Interlock Diagram

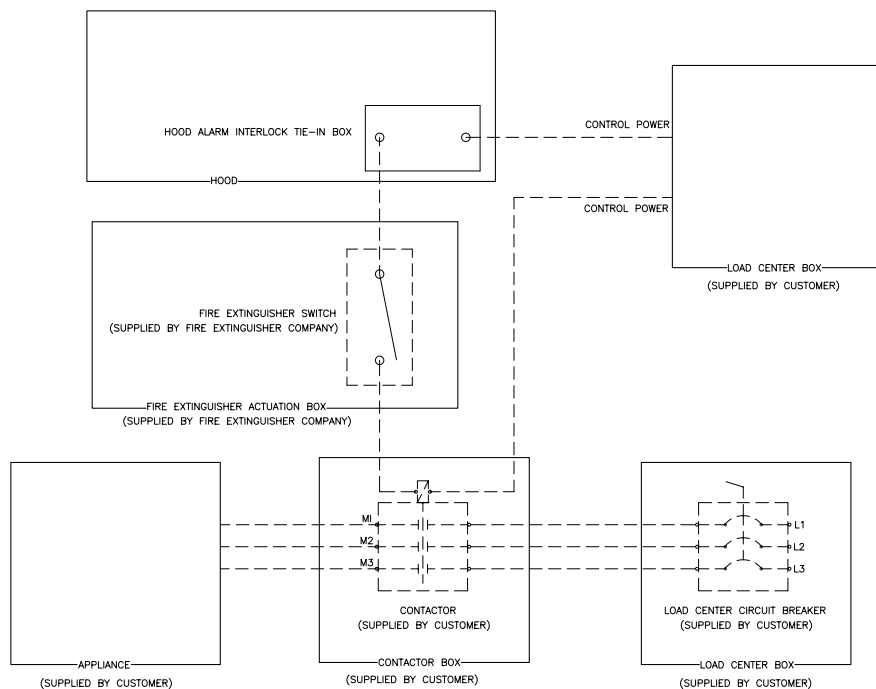

2.6 Fire Suppression System Installation

It is a requirement that the Giles EH-5 & 6 Environmental Hood System be protected by a UL Listed fire suppression system (***customer supplied**). Installation must be performed by an Authorized Fire Suppression Agent in accordance with the system listing.

The EH-5 & 6 hood system has factory-installed piping, plenum discharge nozzles, fusible link brackets and cabling conduit. **Appliance nozzles and drop-downs are not included.** The hood has been designed with pipe and conduit stubbed-out to accommodate either left or right side hook-up. The electrical switch requirements are identical to those listed in the Ansul R-102 Installation Manual with the hood system acting as the customer supplied switch.

1. Use Ansul No. 56922-1W Appliance Nozzles and 165°F (74°C) Fusible Links.
2. Appliance nozzles shall be positioned 11" [279.4mm] below the lowermost front edge of the hood.
3. The use of both appliance nozzles is required at all times.
4. A clearly marked and easily accessible manual pull station for the Fire System is to be installed in a path of exit or egress, in accordance with local code.
5. The Regulated Release Assembly shall be the mechanical type (Ansul P/N 79290).

2.6.1 Fire Suppression System Routing

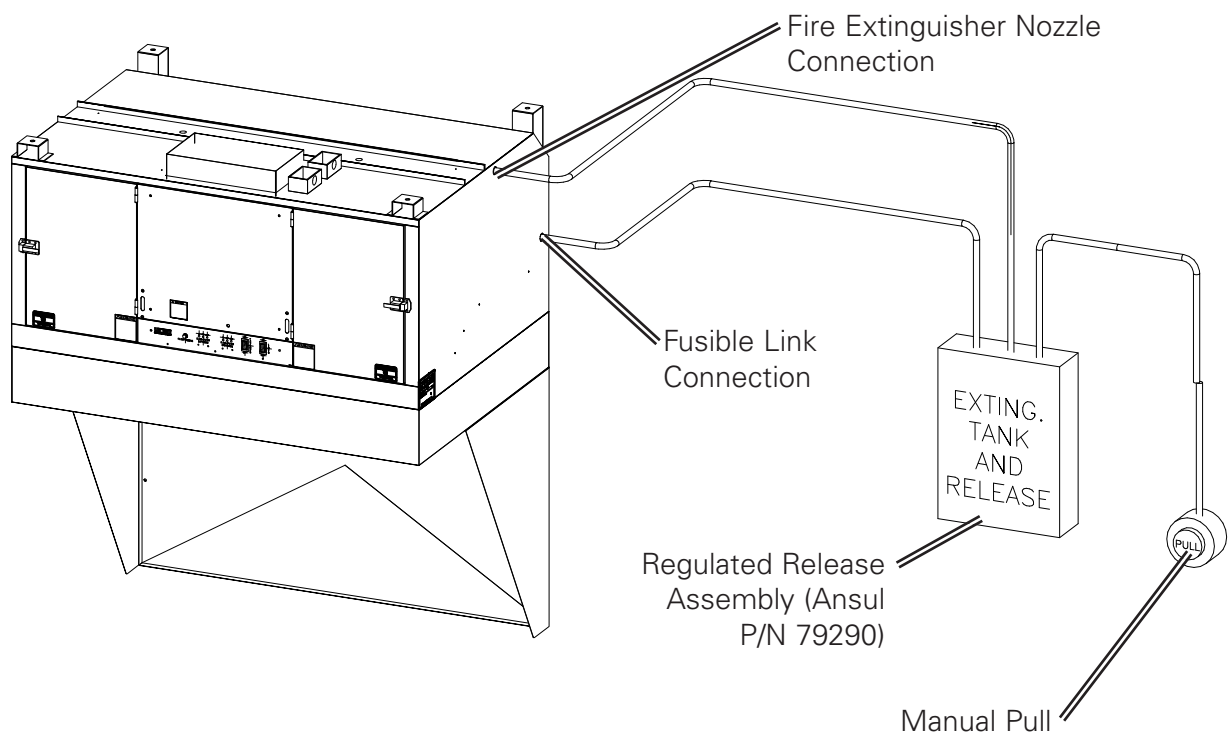

Note: System may be located and connected on the left or right of the hood.

2.6.2 Fire Suppression Fusible Links

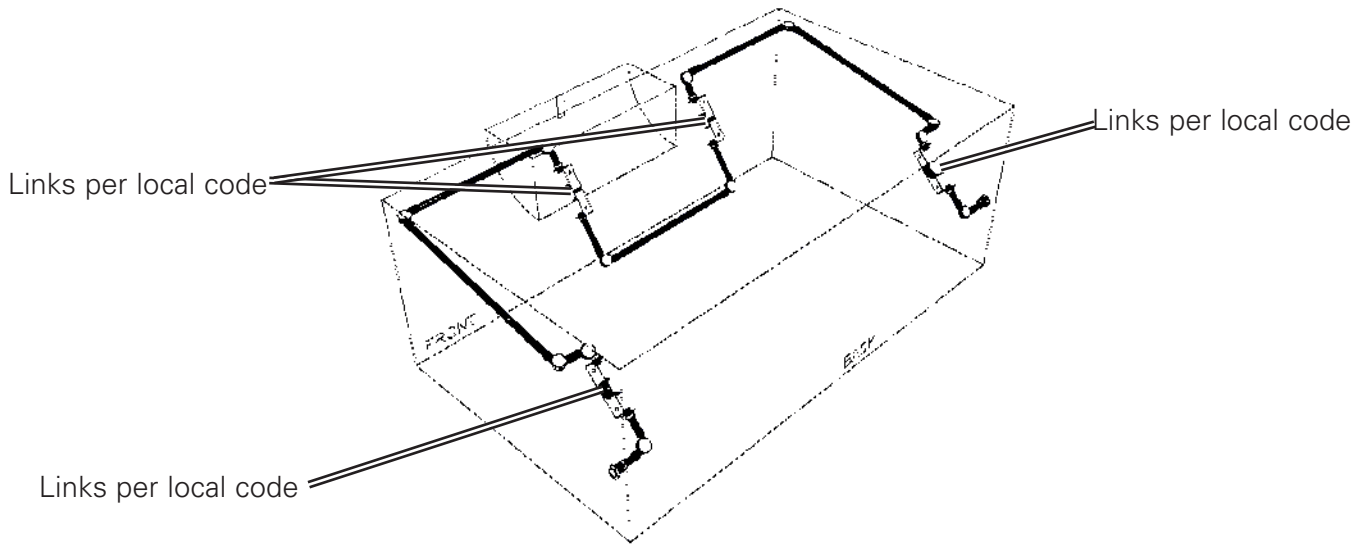

2.6.3 Appliance Nozzles

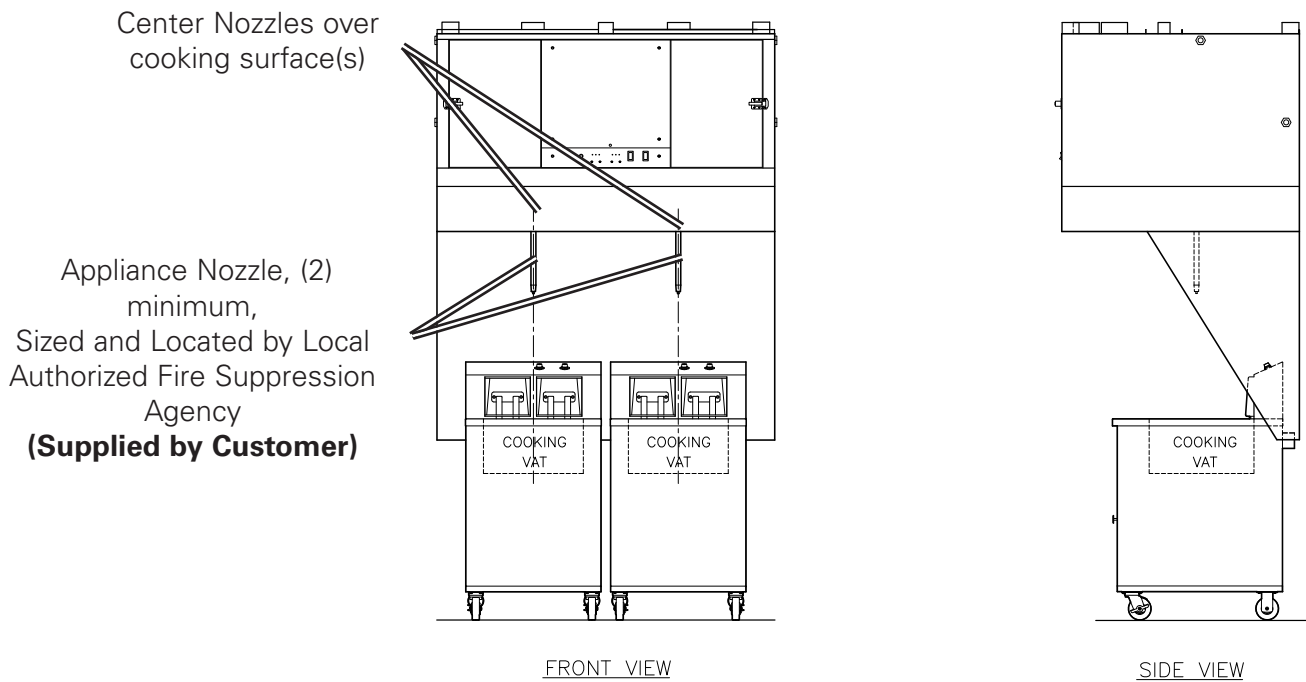

2.6.4 Fire Extinguisher Nozzle Locations

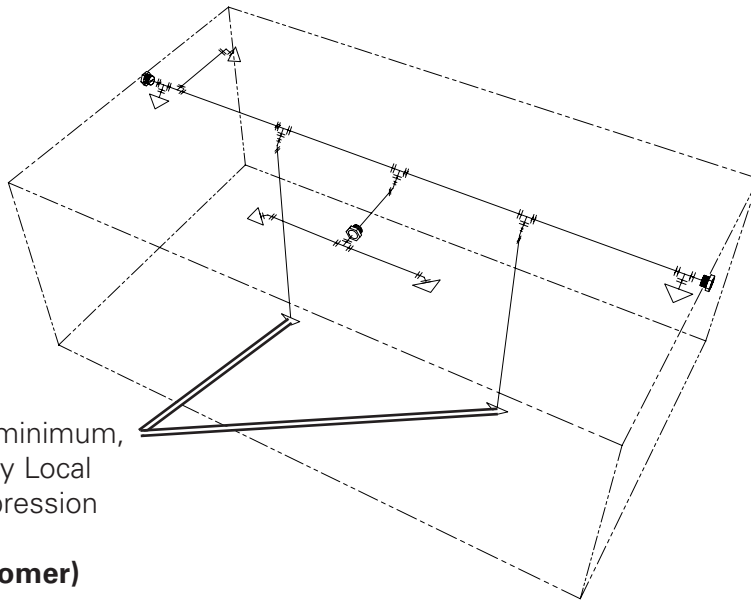

Appliance Nozzle, (2) minimum,
Sized and Located by Local
Authorized Fire Suppression
Agency
(Supplied by Customer)

2.6.5 General Maintenance

The fire extinguishing system must be maintained as outlined in the Standard for Wet Chemical Extinguishing Systems, NFPA 17A and in accordance with the instructions of the system's installer.

Please contact a local Authorized Fire Suppression Company or Ansul Dealer for maintenance, troubleshooting and repairs.

General Maintenance of the fire suppression system is very important. Inspect and maintain as follows: Servicing and inspection of the fire suppression system is to be conducted by qualified fire protection technicians. As a minimum, field inspection of the system is to be performed semi-annually. Such maintenance shall consist of the following:

1. Confirm that the hazard has not changed.
2. Verify that system pressure is nominal.
3. Inspect the soundness of the discharge spray nozzles and fusible links.
4. Ensure the system is properly located with respect to the appliance.
5. Verify the date the unit was manufactured.
6. Check to be sure the service tag is attached indicating what service was performed and when performed.

*Ansul is a registered trademark.

3. Overview

The following section provides a brief overview of the components, functions, and accessories of the EH-5 and the EH-6. Please review this section carefully before proceeding any further.

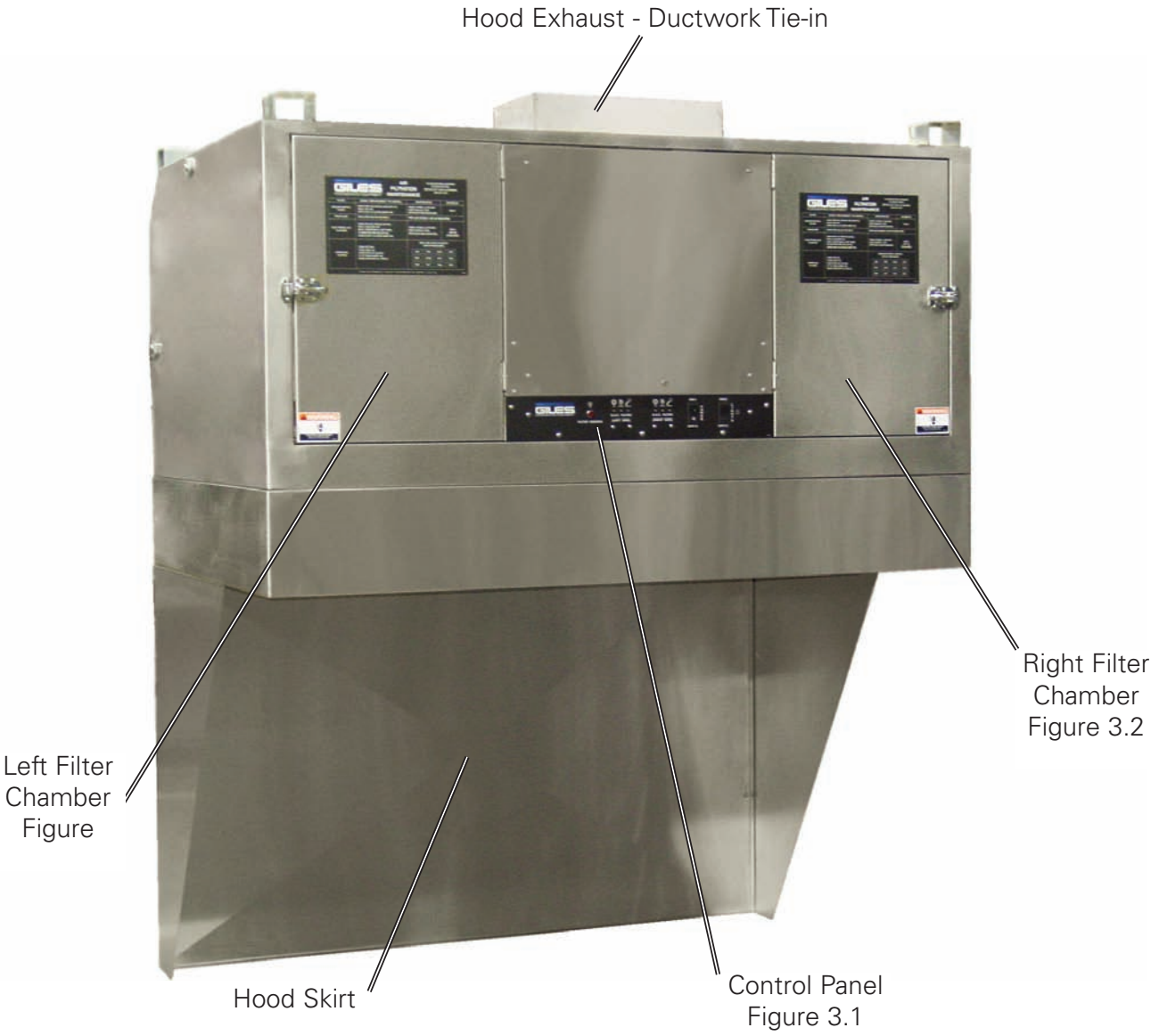

3.1 Control Panel

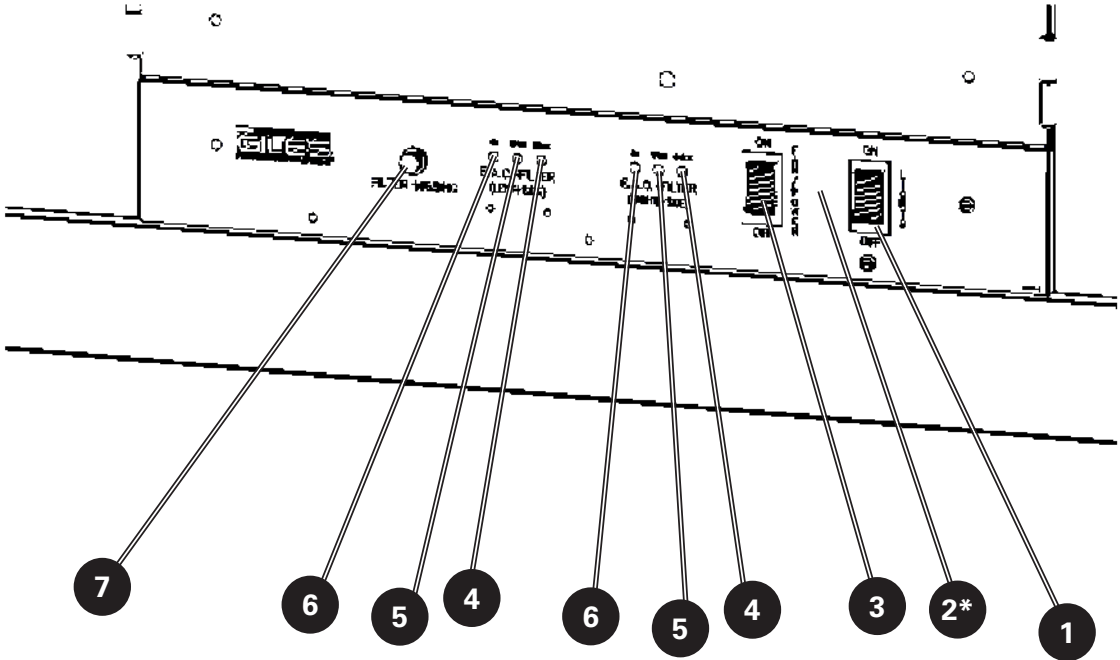

* ILS Only, Not Shown

3.1 Control Panel

Item	Description	Function
1	Light Switch	Operates the under-hood lights.
2*	PUSH to START Button	After the Power Switch is in the "ON" position, push and hold "PUSH to START" Button for 5 seconds. (Only installed on units with ILS (Inter-Locking Start)).
3	Power Switch	The Power Switch is a two-position Switch. Place switch in upward position to the "ON" position for operation.
4	"CHECK" Indicator Light (Right & Left EAC)	The "Check" Indicator Light will turn on when the EAC becomes completely shorted. Indicates EAC is not functioning and needs cleaning or repair.
5	"WASH" Indicator Light (Right & Left EAC)	The "Wash" Indicator Light will come on when the EAC becomes excessively dirty. DO NOT use this light as a signal for routine cleaning of the EAC. Failure to clean the EAC <u>daily</u> will significantly reduce the performance of the EAC, decrease the life of the charcoal filter, and possibly damage the EAC power supply.
6	"ON" LED Indicator (Right & Left EAC's)	The "ON" Indicator Light will turn on when the Electronic Air Cleaner (EAC) power supply is on and the filter is operating normally.
7	Filter Missing Light	The "Filter Missing" Light will turn on if either Grease Baffle Filter, Pre-Filter, or Charcoal Filter is missing or are not properly positioned in the hood.

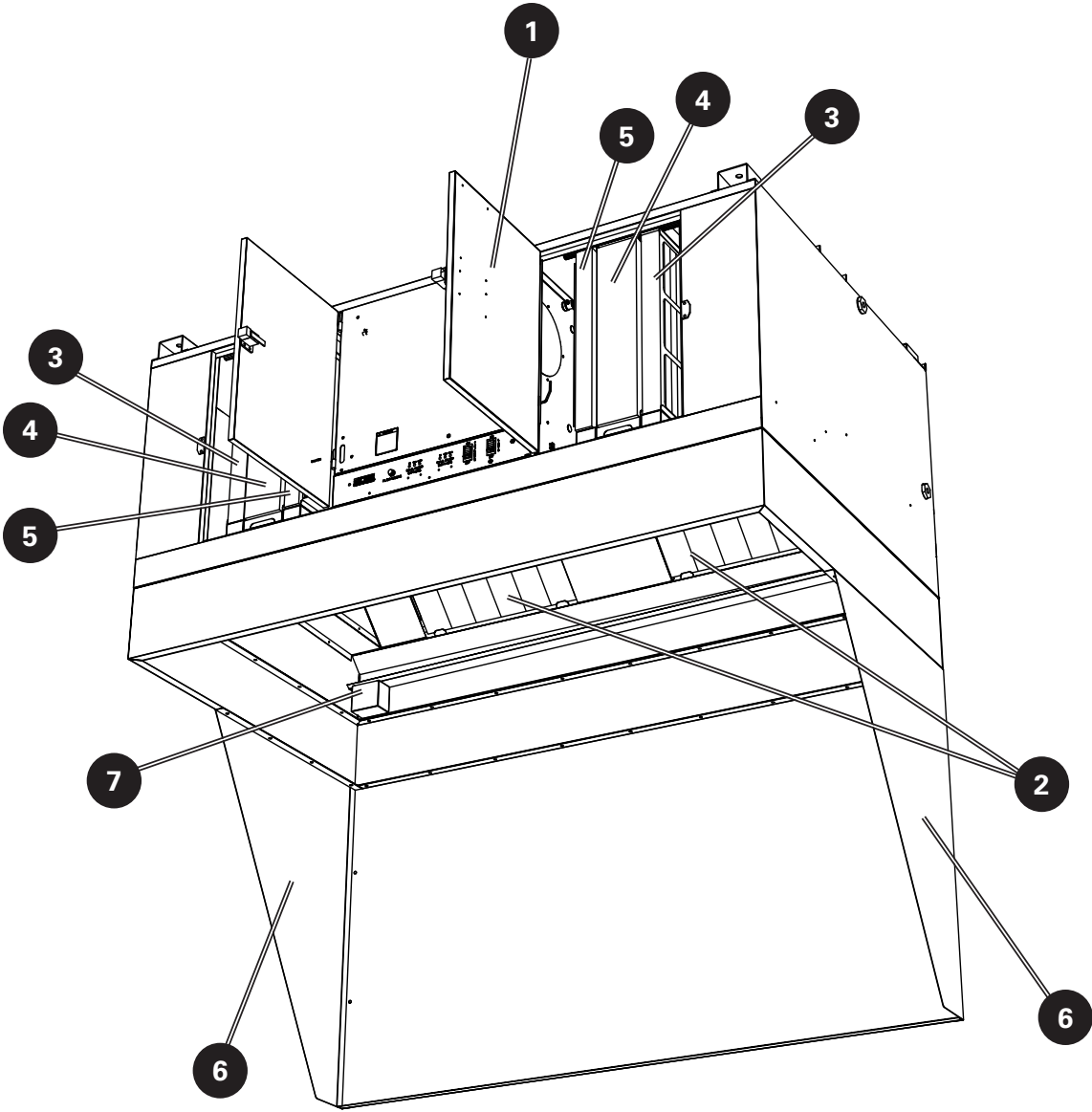

* Inter-Locking Start (ILS) Only

3.2 Filter Chamber and Exhaust





3.2 Filter Chamber and Exhaust

Item	Description	Function
1	Hood Filter Doors (2)	Access to Pre-Filters, EAC's and Charcoal Filters. Hood will NOT operate unless both doors are closed and latched.
2	Baffle Filters (2)	Baffle Filters are the first stage of the air-cleaning system to capture large grease particles. These filters are easily removed for daily cleaning. To prevent contact with electrical parts and avoid electrical shock, DO NOT attempt to operate Hood with Filter(s) removed. Baffle Filters should be cleaned daily.
3	Pre-Filters (2)	Pre-Filters remove additional grease-laden vapors and moisture from the air stream. To prevent contact with electrical parts and avoid electrical shock, DO NOT attempt to operate Hood with Filter(s) removed. NEVER attempt to clean and re-use Pre-Filters ... Replace with new filters weekly.
4	EAC Filter (Left & Right)	EAC Filters are electrostatic devices that remove fine grease vapor and smoke produced from cooking. To prevent contact with electrical parts and avoid electrical shock, DO NOT remove the EAC Filter while the hood is operating ... The EAC should be cleaned daily.
5	Charcoal Filters (2)	Charcoal Filters helps to eliminate cooking odors. These Filters should be replaced monthly. To prevent contact with electrical parts and avoid electrical shock, DO NOT attempt to operate Hood with Filter(s) removed. NEVER attempt to clean and re-use the Charcoal Filters ... Replace with new filters every 30 days.
6	Hood Side Skirts	The Hood Skirt helps contain and capture grease laden vapors produced by the cooking appliance.
7	Grease Drip Cup	The Grease Drip Cup is used to catch grease condensate generated at the Baffle Filters. This cup should be emptied and cleaned daily.

3-03. Accessories (Included)		
Part	Description/Part Number	Function
	<p>Baffle Filter P/N 42300</p> <p>(2) Required</p>	<p>Removes large grease particles from the incoming air.</p>
	<p>Pre-Filter P/N 91707</p> <p>(2) Required</p>	<p>Removes additional grease particulate and moisture from the incoming air.</p>
	<p>EAC Filter P/N 20521 (LEFT) P/N 20520 (RIGHT)</p>	<p>Removes smoke and fine particle contaminants from the incoming air.</p>

3-03. Accessories (Included)

Part	Description/Part Number	Function
 A rectangular, metallic charcoal filter with a grid of small holes on its surface.	Charcoal Filter P/N 32056 (2) Required	Helps remove cooking odors from the air stream.
 A rectangular, metallic soak tank with a black interior and a lid.	EAC Soak Tank P/N 39327	Used for soaking and cleaning EAC filter.



Notes:

4. Operation & Filter Maintenance

This section describes Hood operation and filter maintenance.

4.1 Hood Operation

Starting the Hood ... Make sure all Filters are in place and filter access doors are closed before attempting to operate the unit. **NOTE: The hood will NOT power-up if either Filter Door is open.**

1. Press the Power Switch **1** to the **ON** position, (if ILS model, press and hold the **"Push & Hold to Start"** Button **2** for 5 seconds). Fan will start and both EAC **ON** lights **3** will illuminate. The served cooking appliance, which is interlocked to the hood may now be operated.
2. Place the Light Switch **4** to the **ON** position to turn on the under-hood lights.

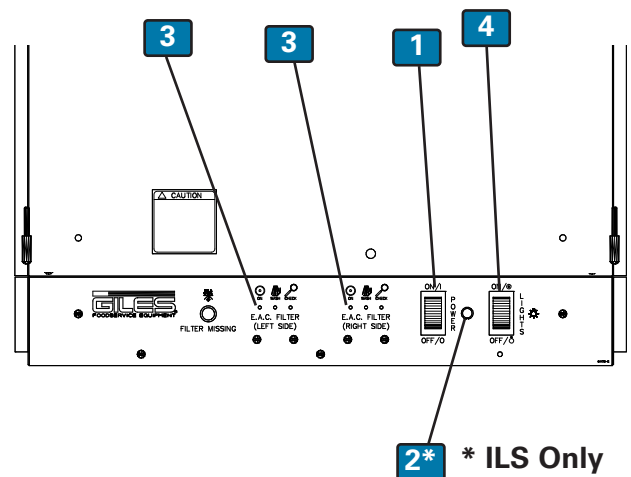

4.2 Filters and Filter Maintenance

Filter System operation, cleaning and maintenance schedule

4.2.1 Environmental Hood Filter Table

Filter	When to clean or replace	How to remove	How to clean	How to install
Baffle Filter	Clean daily	Section 4.2.2	Section 4.2.5	Section 4.2.3
Pre-Filter	Replace weekly	Section 4.2.6.	DO NOT attempt to clean, Replace ONLY Section 4.2.9	Section 4.2.7
EAC Filter	Clean daily	Section 4.2.10	Section 4.2.13	Section 4.2.11
Charcoal Filter	Replace every 30 days	Section 4.2.14	DO NOT attempt to clean, Replace ONLY Section 4.2.17	Section 4.2.15

4.2.2 Baffle Filter Removal

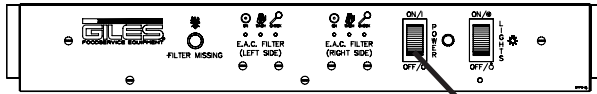

1 Place in OFF position

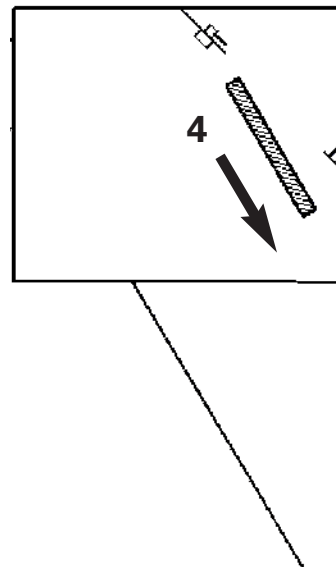
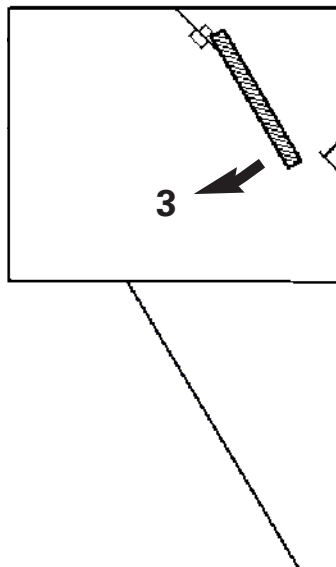
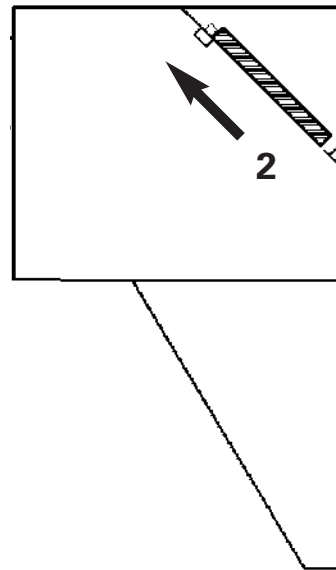
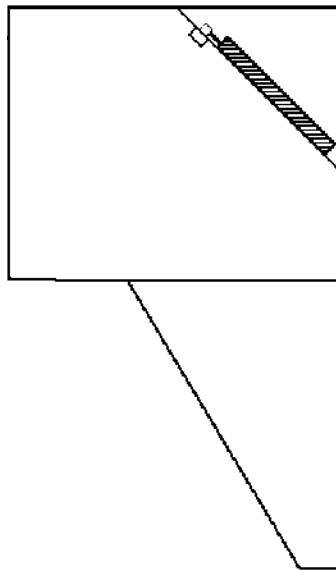

4.2.3 Baffle Filter Installation

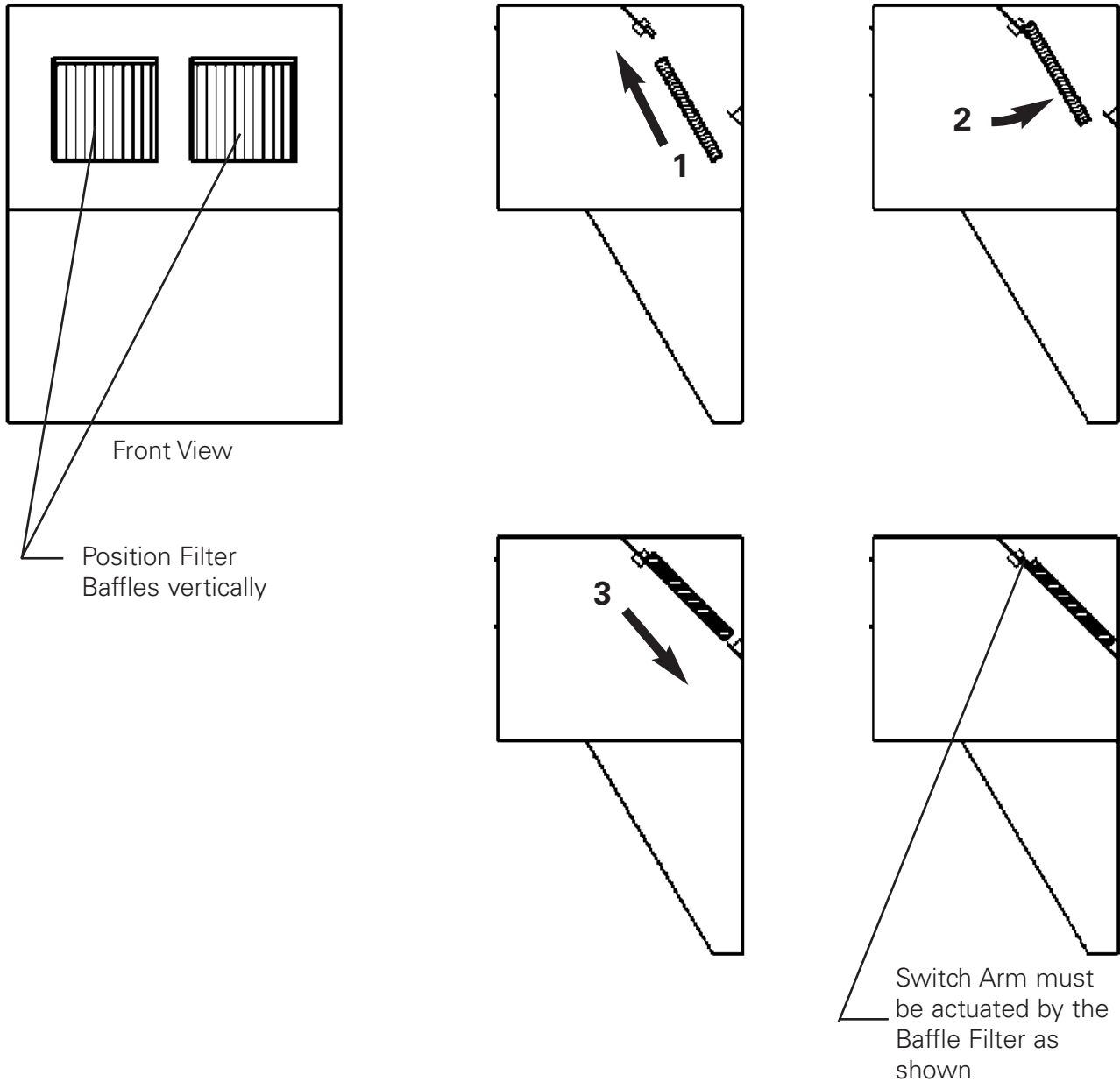

4.2.4 Baffle Filter Missing

If either Baffle Filter is missing, or not positioned correctly, the Filter Missing Light **1** will illuminate and power to cooking appliance is interrupted until the condition is corrected. See Section 4-2.03 Baffle Filter Installation.

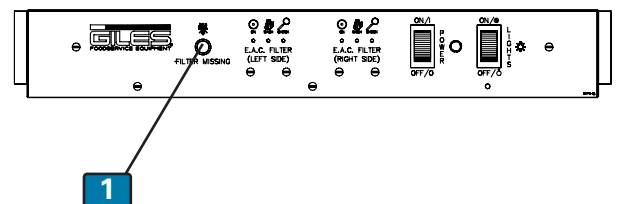

4.2.5 Baffle Filter Cleaning

Grease Baffle Filters should be cleaned daily. Place them in sink and clean with a mild bio-degradable degreaser. Dry filters thoroughly and reinstall in the unit.

4.2.6 Pre-Filter Removal

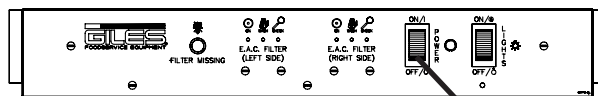

1 Place in OFF position

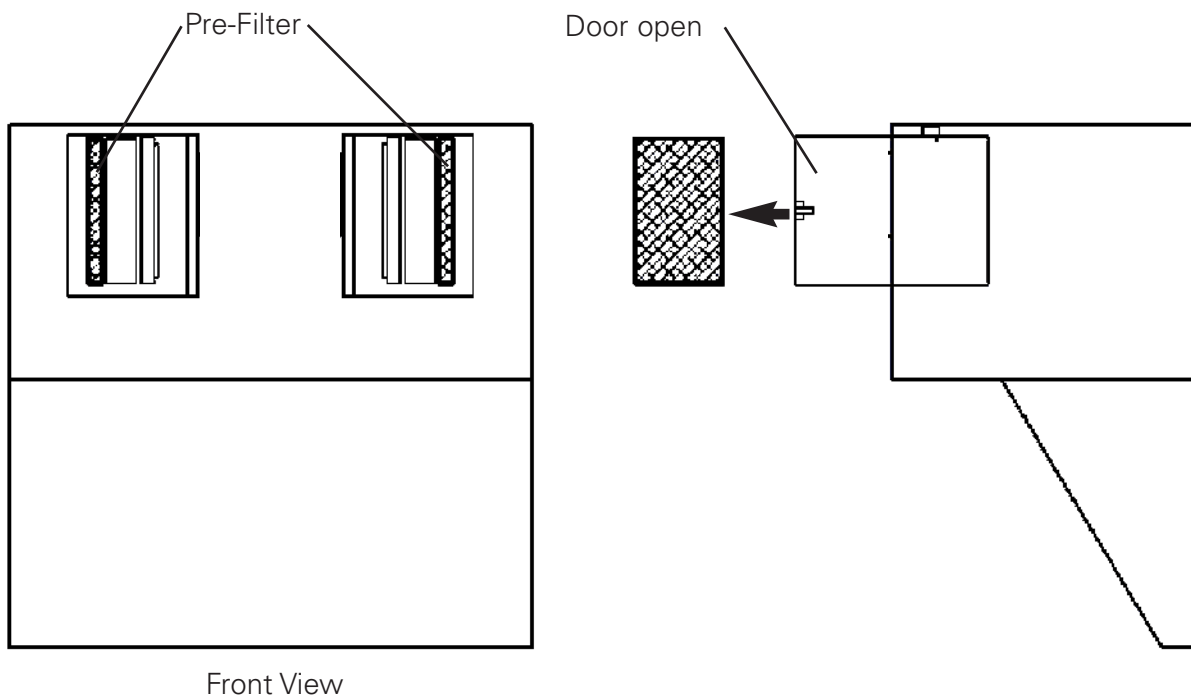

4.2.7 Pre-Filter Installation

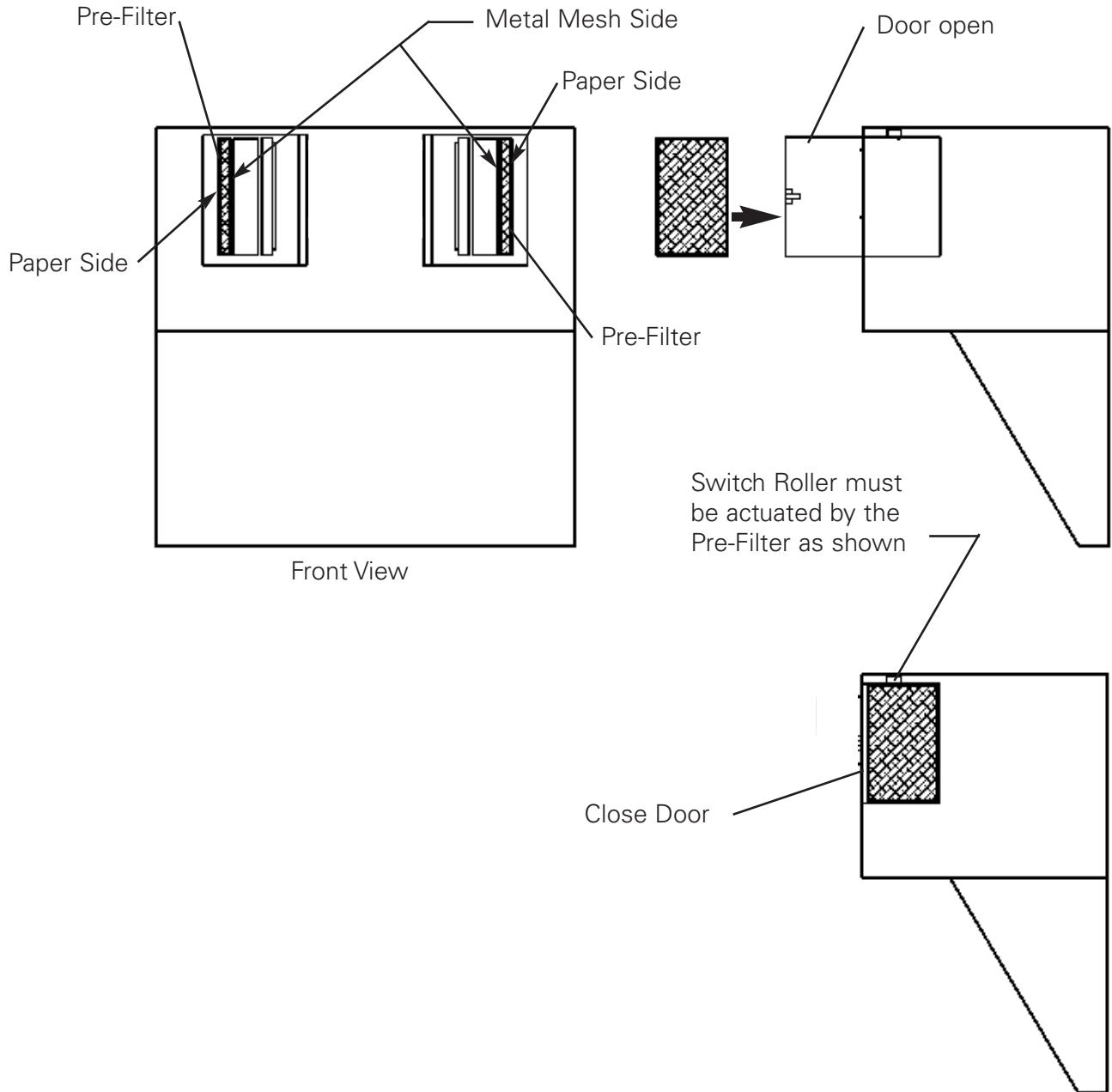

4.2.8 Pre-Filter Filter Missing

If either Pre-Filter is missing or not properly positioned, the Filter Missing Light **1** will illuminate and power to cooking appliance is interrupted until the condition is corrected. Section 4.2.7 Pre-Filter Installation.

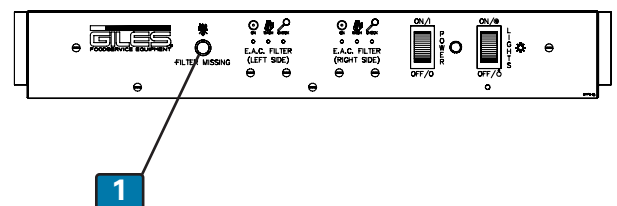

4.2.9 Pre-Filter Replacement



- NEVER attempt to clean and re-use the Pre-Filter. Damage to the unit could result.

Replace the Pre-Filter weekly. Use Replacement Part No. 91707. As an aid to proper filter maintenance, please take the time to record the install date of the new filter in the space provided on the label.

4.2.10 EAC Filter Removal

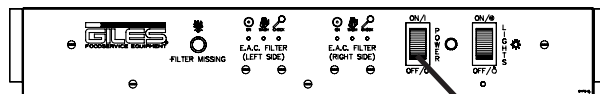

1 Place in OFF position

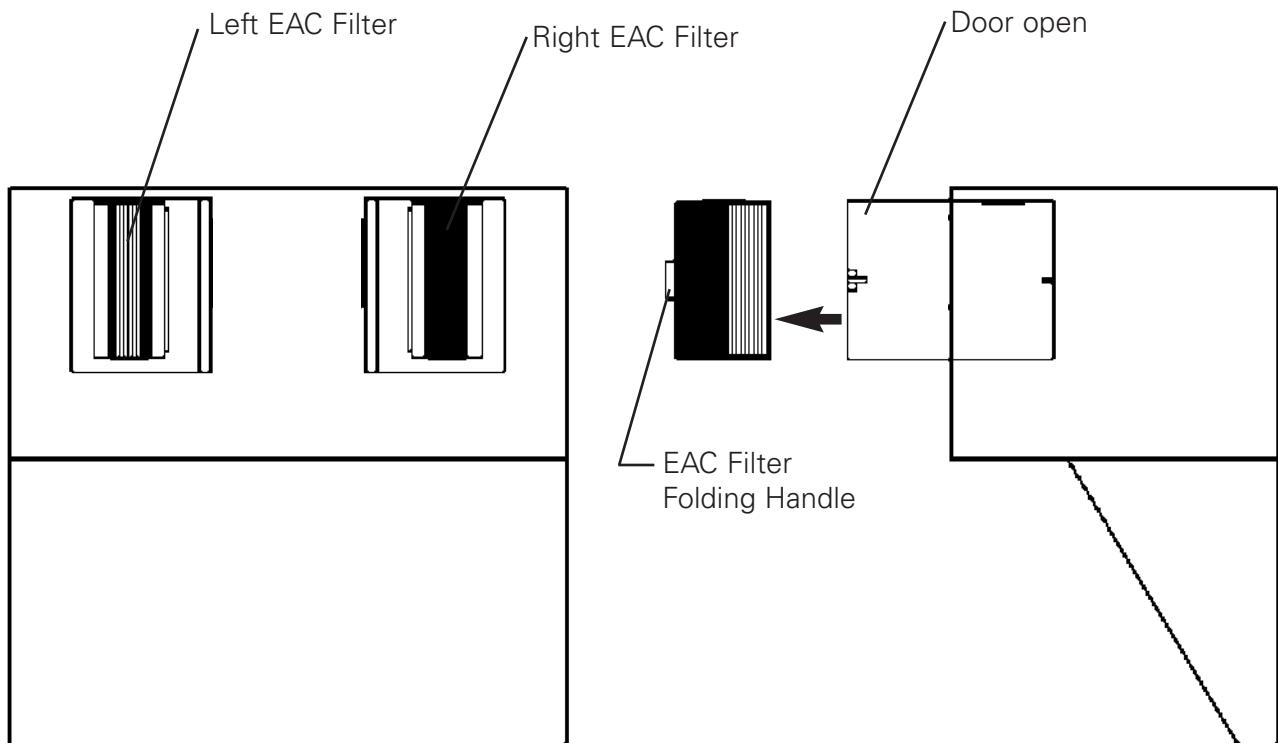

4.2.11 EAC Filter Installation

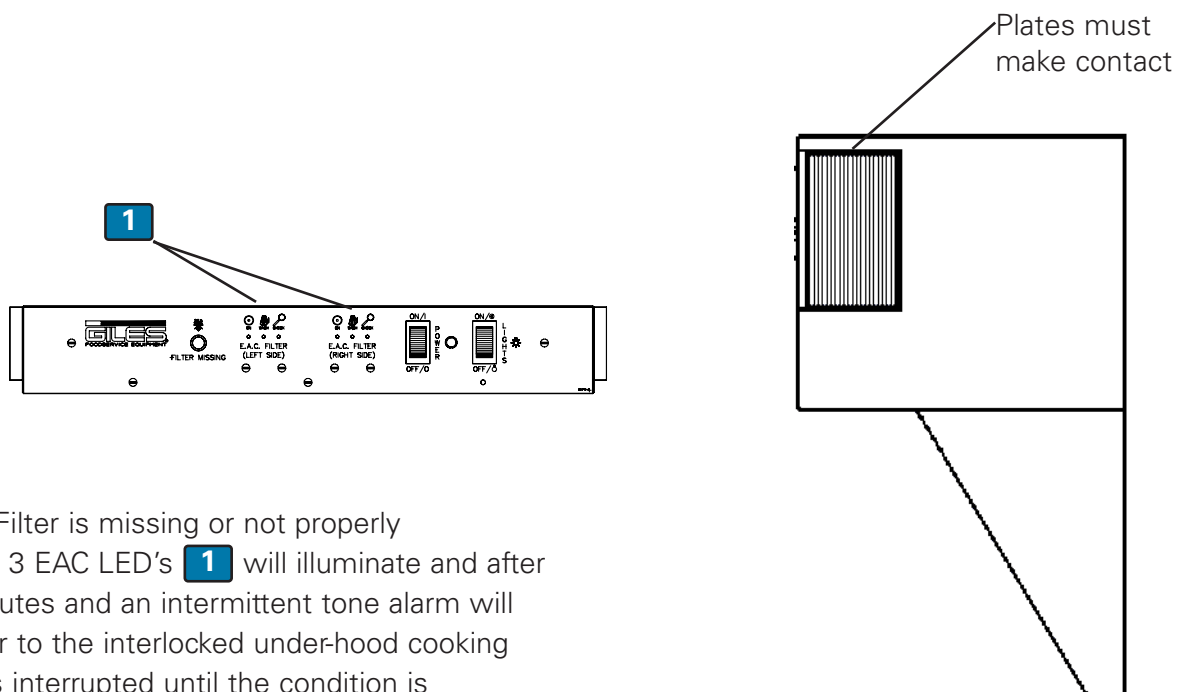
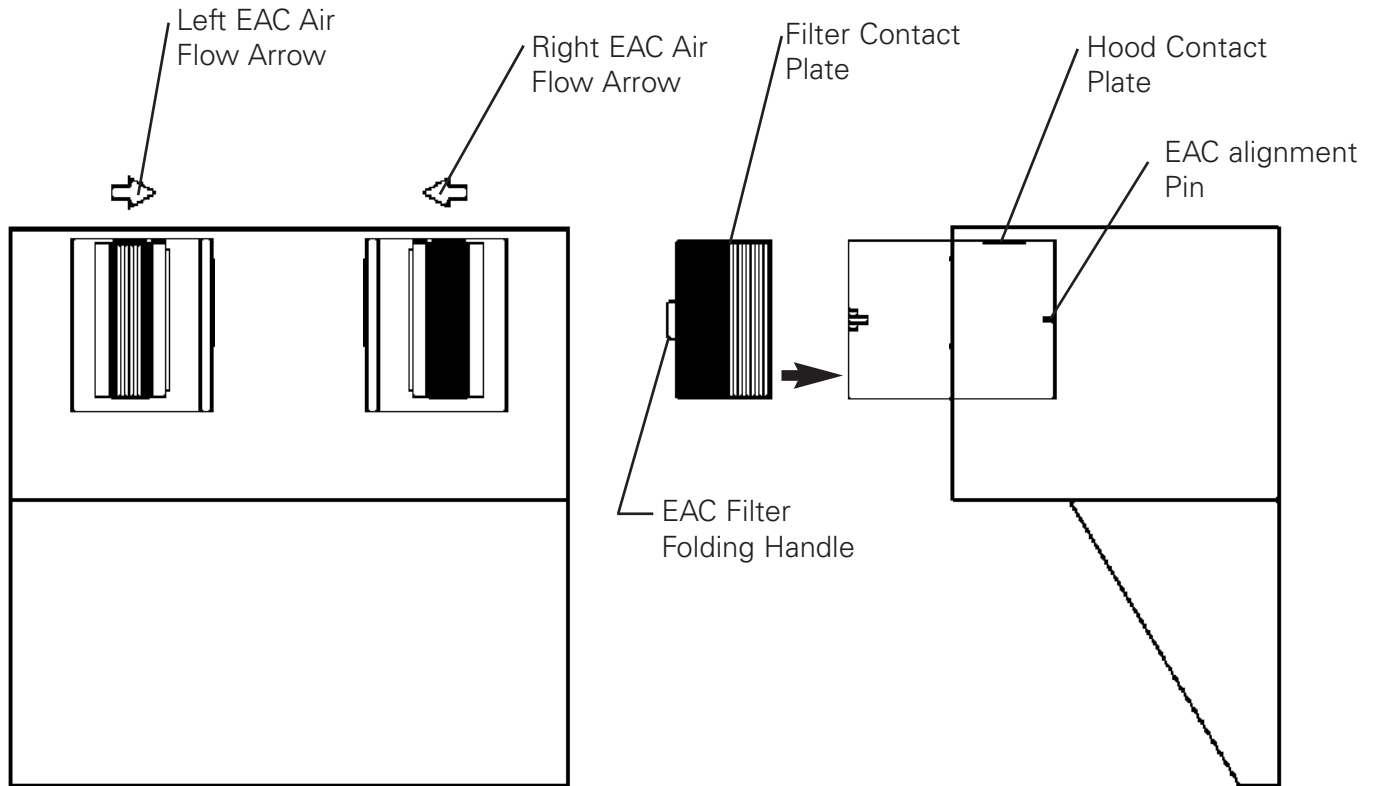

If either EAC Filter is missing or not properly positioned, all 3 EAC LED's **1** will illuminate and after approx. 2 minutes and an intermittent tone alarm will sound. Power to the interlocked under-hood cooking appliance(s) is interrupted until the condition is corrected.

4.2.12 EAC Filter Status

Three LED indicator lights on the Control Panel display the status of each EAC Filter.

- 1 ON** **ON** and other LED's **OFF** ... the EAC Filter is in place, powered and operating properly.
- 2 WASH** When **ON**, indicates the collection fins are becoming excessively dirty and must be cleaned. After approx. 2 minutes in this condition, an intermittent tone alarm will sound and power to interlocked under-hood cooking appliance(s) will be interrupted until the condition is corrected.
- 3 CHECK** When **ON**, indicates the Filter is not operating. There is either a poor connection at the contacts or the filter is damaged. After approx. 2 minutes in this condition, an intermittent tone alarm will sound and power to interlocked under-hood cooking appliance(s) will be interrupted until the condition is corrected.

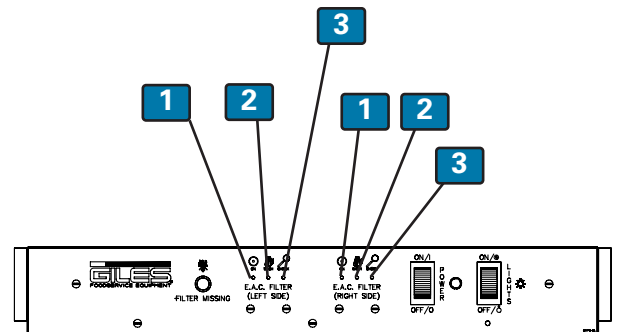

4.2.13 EAC Filter Cleaning

The EAC Filter should be cleaned daily for best performance.

CAUTION

• Do not bend the fins or break the ionizer wires on the EAC as this will prevent the electrostatic collecting cell from performing properly and could potentially void the warranty.

1. Add 1/2 gal of a mild degreaser, such as "Simple Green" or "Clean Magic"; to the Soak Tank **1**, add water to fill line (X's on inside of tank's back) and mix.
2. Holding the cell by the contact plate **2**, carefully lower the EAC **3** into the mixed degreasing solution.
3. Allow the EAC to soak for 20 to 30 minutes. Grasping it by the contact plate **2**, lift and gently jog it up and down in the solution to help dislodge grease residue.
4. Carefully remove the EAC from the tank and rinse thoroughly in a sink using hot water spray.
5. Allow the cell to air dry, thoroughly.
6. Inspect cell for broken wires or bent fins, Have broken wires replaced promptly. Bent fins may be gently straightened by hand, if needed.

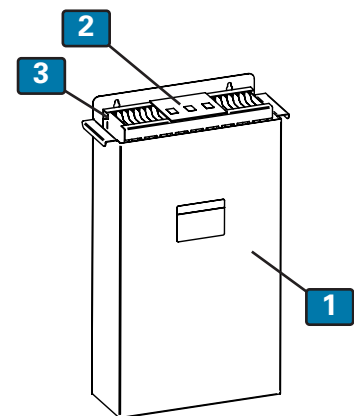

NOTE: The EAC cell is NOT designed to withstand washing in commercial dishwashers. Harsh degreaser products can damage the collection fins and cell body.

4.2.14 Charcoal Filter Removal

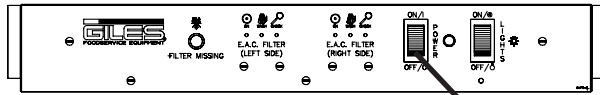

1 Place in OFF position

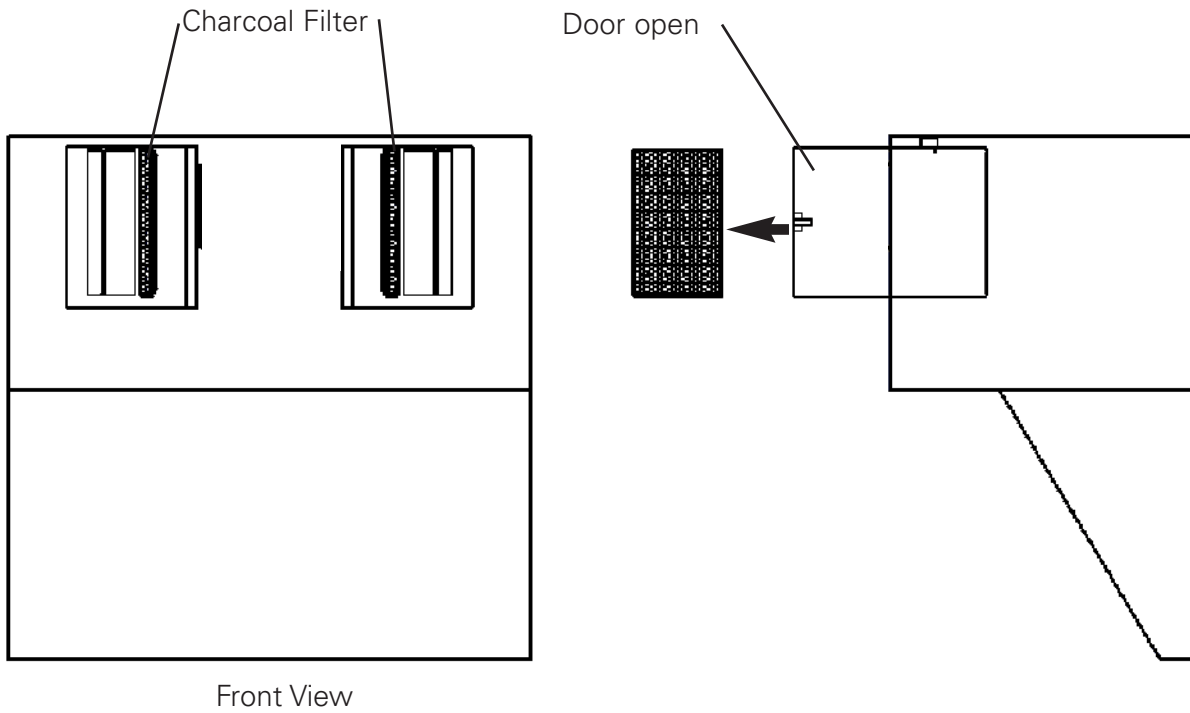

4.2.15 Charcoal Filter Installation

NOTE:

- As an aid to proper filter maintenance, please take the time to record the install date of the new filter in the space provided on the label.

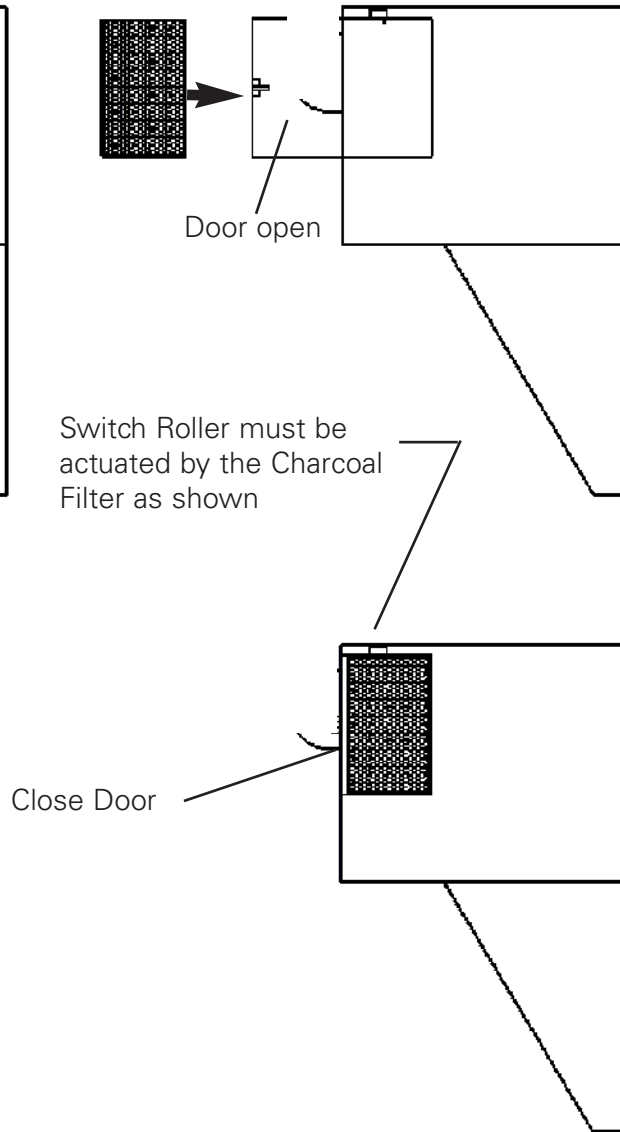
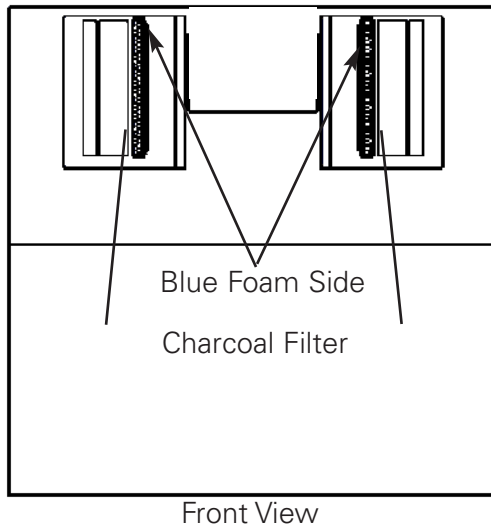

4.2.16 Charcoal Filter Missing

If either Charcoal Filter is missing or not properly positioned and the unit is on, the Filter Missing Light **1** will illuminate and power to cooking appliance is interrupted until the condition is corrected. Section 4.2.15 Charcoal Filter Installation.

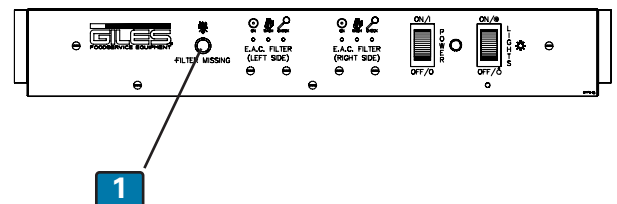

4.2.17 Charcoal Filter Replacement



WARNING

- **NEVER attempt to clean and re-use the Charcoal Filter. Damage to the unit could result.**

Replace the Charcoal Filter every 30 days. Use Replacement Part No. [32056](#). As an aid to proper filter maintenance, please take the time to record the install date of the new filter in the space provided on the label.

4.3 Filter Alarm Chart

Alarm Sound	What will happen	Filter effected	Cause	Solution	See Section
Continuous tone	Alarm will sound and the power to the appliance will shutdown. (If ILS model, the hood fan will also shutdown)	Charcoal	Filter dirty	Replace Filter	4.2.15 and 4.2.17
Continuous tone	Alarm will sound and the power to the appliance will shutdown. (If ILS model, the hood fan will also shutdown)	Pre-Filter	Filter dirty	Replace Filter	4.2.7 and 4.2.9
Continuous tone	Alarm will sound and the power to the appliance will shutdown. (If ILS model, the hood fan will also shutdown)	Baffle	Filter dirty	Clean Filter	4.2.3 and 4.2.5
Intermittent tone	“Check” and/or “Wash” LED’s will illuminate, alarm sounds, after approx. 2 minutes, power to the appliance is shutdown. (If ILS model, the hood fan will also shutdown)	E.A.C.	Filter dirty	Clean Filter	4.2.11 and 4.2.13

5. Hood Cleaning and Maintenance

This Section describes cleaning and maintenance procedures pertaining to the Hood System. Attention to these instructions will help ensure that hood performance remains optimal.

A **Maintenance & Service Log** is provided in this manual, see Table 5.6.

5.1 Monthly Interlock Check

The Giles Environmental Hood System is designed with various interlock circuits to ensure the unit operates in a safe and effective manner. These interlocks should be tested MONTHLY as described below. Use the **Maintenance & Service Log** provided in this Manual to record and track these unit checks. If a problem is found call your service representative.

1. **Baffle Filter Check:** Place power switch in the **OFF** position, remove the left-side Baffle Filter ... turn power **ON**. "Filter Missing Light" should be illuminated. Check appliance power, there should be none. Turn power **OFF** and reinstall the Grease Baffle Filter. Follow the same procedure to check the right-side Filter.
2. **Pre-Filter/Door Interlock Check:** Turn power switch **ON** ... with Hood running, slightly open the Filter Access door ... confirm Hood shutdown when door is opened ... turn power switch **OFF**. Remove the left-side Pre-Filter and close door ... turn power **ON**. "Filter Missing Light" should be illuminated. Check appliance power, there should be none. Turn power **OFF** and reinstall Pre-Filter. Follow the same procedure to check the right-side Pre-Filter.
3. **EAC Filter Check:** Place power switch in the **OFF** position, remove the left-side EAC Filter and close door ... turn power **ON**. Wait 2 minutes ... intermittent alarm should sound. Check appliance power, there should be none. Turn power switch **OFF** and reinstall EAC Filter. Follow the same procedure to check right-side EAC Filter.
4. **Charcoal Filter Check:** Place power switch in the **OFF** position, remove the left-side Charcoal Filter and close door ... turn power **ON**. Check appliance power, there should be none. Turn power switch **OFF** and reinstall Charcoal Filter. Follow the same procedure to check the right-side Charcoal Filter.
5. **Filter Clogged Check:** Place Hood power switch in the **ON** position. The blower will start and a continuous tone alarm should sound for 2 to 8 seconds until the blower reaches speed, then silence. Check appliance(s) power during this time; there should be no power supplied to appliance(s) until the alarm silences. If the alarm tone does not sound, fails to silence, and/or the appliance(s) fails to come on or comes on before the alarm silences, contact service agent and have the Clogged Filter interlock checked. Return Hood power switch to the **OFF** position.

5.2 Quarterly Hood Cleaning

To maintain effectiveness and performance, the hood must be cleaned, at a minimum, every 3 months. Disconnect power from the unit, preferably at a breaker. Remove all filters from the hood. Using soft cloth, sponge or towel, and a mild bio-degradable degreaser, clean the entire hood plenum and discharge duct section. A qualified hood and duct cleaning service should be contracted to clean the hood's exhaust ductwork, fan, and roof vent on a quarterly basis, or as mandated by local code.

5.3 Semi-Annual Fire Suppression System Service

Inspection & servicing of the fire suppression system must be performed by certified, qualified fire protection equipment specialists. As a minimum, field inspection of the Fire Suppression System must be conducted semi-annually and shall consist of the following:

Place fire extinguishing system locking bar on fire system when inspecting or servicing.

1. Inspect storage tank for chemical level and charge pressure. Inspect release mechanism.
2. Check all nozzles to insure they are free of grease buildup. Refer to **Section 2.6.4, Extinguisher Nozzle Locations**.
4. Test the remote manual pull station for activation and wear.
5. Install test link and cut to simulate automatic actuation.
6. Clean and inspect fusible links. Refer to **Section 2.6.2, Fusible Link Locations**.
7. Inspect fusible link wire cabling for wear at pulleys and detectors ... replace if necessary.
8. Record maintenance date and service performed in a permanent file.

5.4 Annual Fire Suppression System

Same as Semi-Annual Inspections except all fusible links must be replaced with new. Refer to **Section 2.6.2, Fire Suppression Fusible Links**.

5.5 12-Year Fire Suppression System Service

Same as Annual except for the following:

1. Replace R-102 fire suppressant chemical.
2. Hydrostatically test the holding tank and charging cartridge. These can be replaced with new components that have current hydrostatic certifications.
3. Flow test the regulator.

5-6. Maintenance & Service Log

Check								Initial/Date	Check								Initial/Date				
✓	✓	✓	✓	✓				<i>ABC</i>	1/2/03	1	2	3	4	5							
1	2	3	4	5						1	2	3	4	5							
1	2	3	4	5	6					1	2	3	4	5	6						
1	2	3	4	5						1	2	3	4	5							
1	2	3	4	5	6	7*	8*			1	2	3	4	5	6	7*	8*				
1	2	3	4	5						1	2	3	4	5							
1	2	3	4	5	6					1	2	3	4	5	6						
1	2	3	4	5						1	2	3	4	5							
1	2	3	4	5	6	7*	8*			1	2	3	4	5	6	7*	8*				
1	2	3	4	5						1	2	3	4	5							
1	2	3	4	5	6					1	2	3	4	5	6						
1	2	3	4	5						1	2	3	4	5							
1	2	3	4	5	6	7*	8*			1	2	3	4	5	6	7*	8*				
1	2	3	4	5						1	2	3	4	5							
1	2	3	4	5	6					1	2	3	4	5	6						
1	2	3	4	5						1	2	3	4	5							
1	2	3	4	5	6	7*	8*			1	2	3	4	5	6	7*	8*				
1	2	3	4	5						1	2	3	4	5							
1	2	3	4	5	6					1	2	3	4	5	6						
1	2	3	4	5						1	2	3	4	5							
1	2	3	4	5	6	7*	8*			1	2	3	4	5	6	7*	8*				
1	2	3	4	5						1	2	3	4	5							
1	2	3	4	5	6					1	2	3	4	5	6						
1	2	3	4	5						1	2	3	4	5							
1	2	3	4	5	6	7*	8*			1	2	3	4	5	6	7*	8*				

1	Baffle Filter Check	Section 5-1.
2	Pre-Filter Check	Section 5-1.
3	EAC Filter Check	Section 5-1.
4	Charcoal Filter Check	Section 5-1.
5	Filter Clogged	Section 5-1.
6	Quarterly Cleaning	Section 5-2.
7*	Fire Suppression System	Section 5-3.
8*	Fire Suppression System replace Fusible Links	Section 5-4.

*** Must be performed by a certified, qualified fire protection equipment company.**



Notes:

6. Troubleshooting

This section describes basic troubleshooting procedures for the EH-5 & 6. The wiring diagram provided with the unit will assist qualified technicians with more in-depth troubleshooting.

⚠ DANGER

- Electrical troubleshooting procedures should be performed **ONLY** by a qualified service technician or electrician. Death or serious injury will result from contact with energized electrical components.
- Failure to comply with these **DANGER** notices will result in death or serious injury, equipment/property damage, and could void the warranty.

6-1. Troubleshooting Procedures

Problem	Probable Cause	Repair Procedure
Hood will not turn on	a. (ILS Only) "HOLD TO START" button not held for 5 seconds	a. Hold down "HOLD TO START"
	b. Faulty power switch	b. Replace power switch.
	c. Improper supply voltage	c. Connect to proper voltage source.
	d. Filter Access Door not closed	d. Close access door.
	e. Not connected to power source	e. Connect to proper power source.
	f. Blown fuse or tripped circuit breaker.	f. Check the fuse or breaker.
Filter Missing Light on • Initial Start-up Only	a. Baffle filter is not installed	a. Install Baffle filter.
	b. Charcoal or Pre-Filter is not installed	b. Install charcoal or pre-filter.
Check or Wash Light on • LED light cluster for each side's filter.	a. EAC shorted	a. Replace or repair EAC.
	b. EAC dirty	b. Clean EAC.
	c. High voltage power supply faulty.	c. Replace high voltage power supply
	d. High voltage wires shorted.	d. Correct shorted condition.
	e. Faulty contact plate	e. Replace contact plate.

6.1 Troubleshooting Procedures (Cont'd.)

Problem	Probable Cause	Repair Procedure
Served appliance will not operate <ul style="list-style-type: none"> • Hood power ON • FILTER MISSING light ON 	a. Baffle Filter missing	a. Install Baffle Filter
	b. Baffle Filter not installed properly	b. Reinstall Baffle Filter
	c. Charcoal Filter missing	c. Install Charcoal Filter
Served appliance will not operate <ul style="list-style-type: none"> • Hood power ON • FILTER MISSING light OFF • Alarm emitting a continuous tone 	a. Charcoal Filter clogged	a. Replace Charcoal Filter
	b. Baffle Filter clogged	b. Clean Baffle Filter
	c. Clogged filter switch out of adjustment	c. Adjust clogged switch only. (initial start-up switch bad)
	d. Kinked vacuum line	d. Remove vacuum line kinks
	e. Fan running slow	e. Check voltage
Served appliance will not operate <ul style="list-style-type: none"> • Hood power ON • Alarm emitting an intermittent tone. 	a. EAC shorted	a. Repair EAC
	b. EAC dirty	b. Clean EAC
	c. EAC power supply faulty	c. Replace EAC power supply
	d. EAC wires shorted	d. Check voltage
	e. Bad contact plate	e. Replace contact plate
	f. EAC module faulty	f. Replace EAC module
	g. EAC ionizer wire broken or missing	g. Replace ionizer wire

7. Parts List

This section lists various replacement parts available for the EH-5 and EH-6.

7.1 Parts Ordering and Service Information

If you require assistance or need repairs, please contact a nearby Giles representative or dealer to assist with locating a service provider in your area or contact Giles Enterprises directly at the following phone numbers:

IN THE UNITED STATES, CANADA or MEXICO

Please call **800.554.4537** during normal business hours, 8:00AM to 5:00PM Central Time; other than normal business hours, call **800.554.4537** and follow recorded options to reach after-hours support.

IN ALL OTHER COUNTRIES

Please call **334.272.1457** during normal business hours, 8:00AM to 5:00PM Central Time; other than normal business hours, call **334.272.1457** and follow the recorded options.

INTERNET

Please visit our website at: **www.gfse.com** or e-mail **services@gfse.com**.

The goal of the Giles team is to provide you with the highest quality service and assistance. You can help us accomplish this by obtaining the following information and having it readily available when calling. The information is recorded on a Serial Plate or Label attached to the unit.



Record information here for quick reference in the future.

Model Name: _____

Serial Number: _____

Phase: _____

Voltage: _____

Nature of Problem: _____



NOTES:



7.2 Electrical Component Drawer

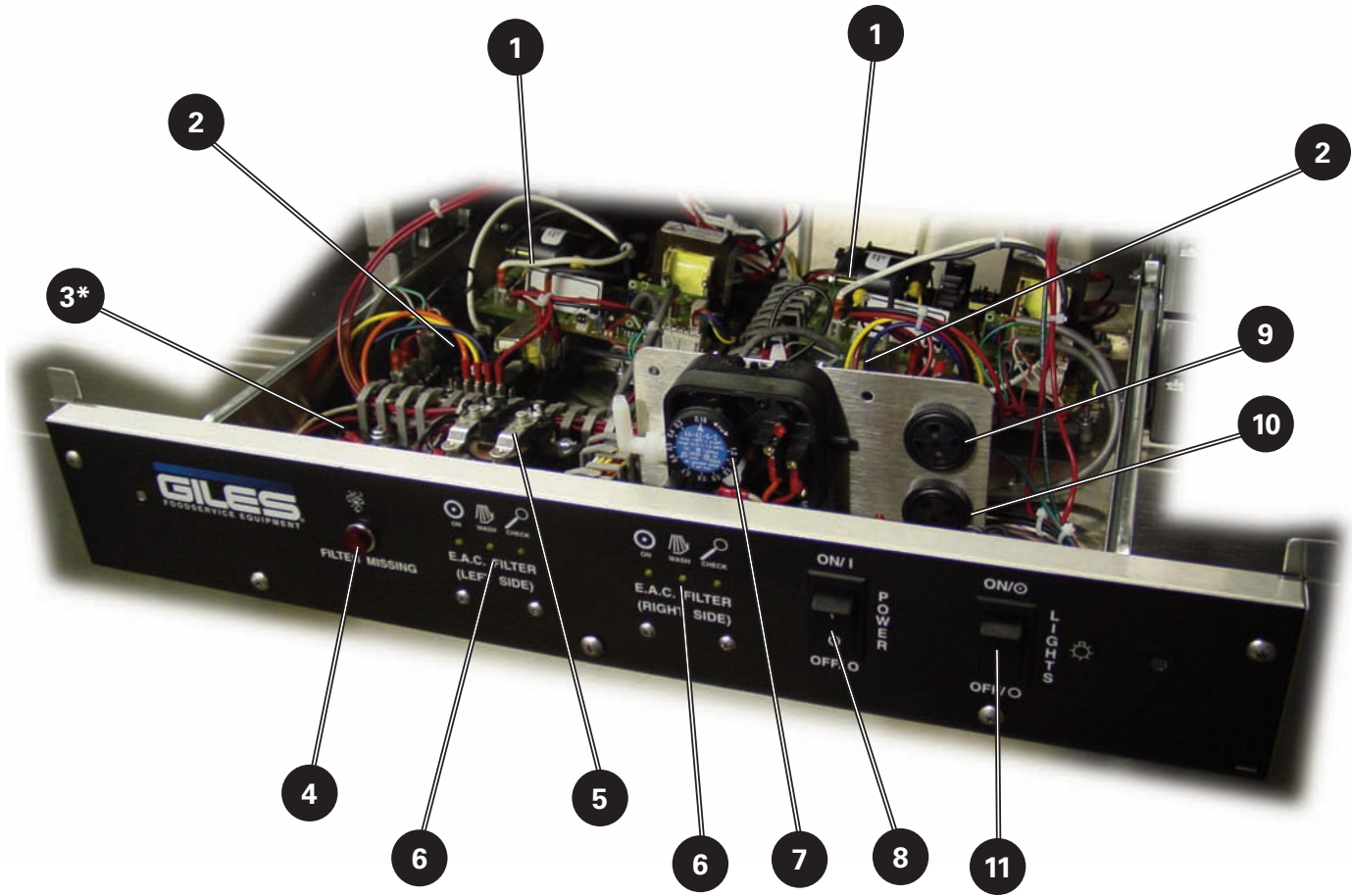

* Not Shown



7.2 Parts List for Electrical Component Drawer

Item	Part No.	Qty.	Description
1	24208	2	EAC POWER SUPPLY, w/DRIVER BOARD, 208-240V
2	23776	2	ALARM & SHUTDOWN MODULE, AIR FILTER
3	23751	1	TERMINAL BLOCK, 6-POLE
4	22300	1	INDICATOR LIGHT, RED, 250V
5	21174	1	RELAY, 30A, 240V, 2 POLE
6	24209	2	LED CLUSTER, EAC STATUS INDICATOR
7	20390	1	SWITCH, VACUUM, ADJUSTABLE
8	21190	1	ROCKER SWITCH, ON-OFF, 250V, 20A, DPST
9	23782	1	SONALERT, 250V, CONTINUOUS TONE
10	22950	1	SONALERT, 250V, INTERMITTENT TONE
11	21052	1	ROCKER SWITCH, ON-OFF-ON, 250V, 20A, DPDT



7.3 Front View - Doors and Panel removed

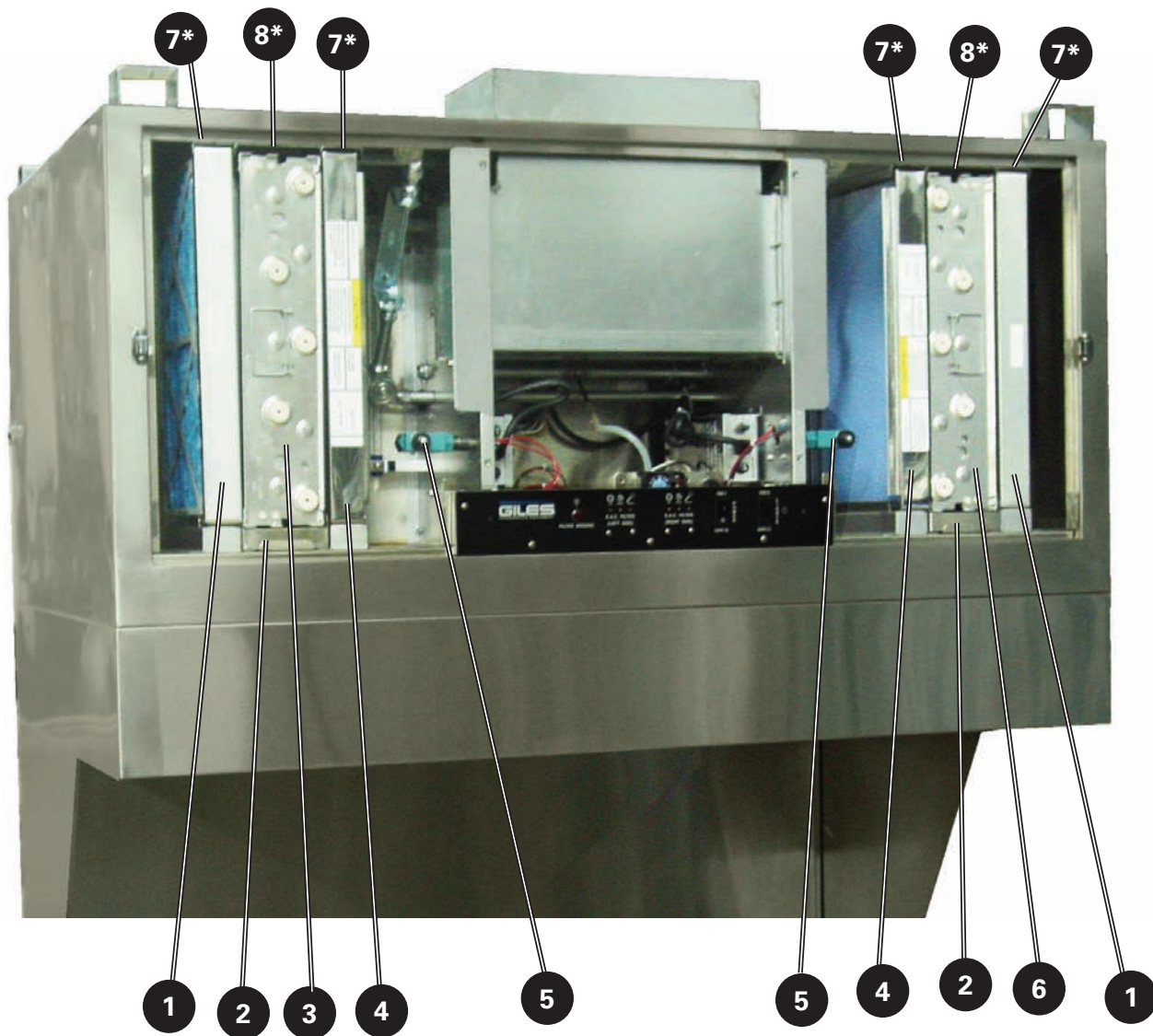

* Not shown

7.3 Parts List for Front View - Doors and Panel removed

Item	Part No.	Qty.	Description
1	91707	2	PRE-FILTER ASSY, 12 X 20 X 2
2	31843	2	E.A.C. FILTER DRIP CUP
3	20521	1	E.A.C. FILTER, 12 X 20, LEFT SIDE ONLY
4	32056	2	CHARCOAL FILTER ASSEMBLY
5	21157	2	DOOR INTERLOCK SWITCH
6	20520	1	E.A.C. FILTER, 12 X 20, RIGHT SIDE ONLY
7	23200	4	SWITCH, SNAP ACTION, ROLLER
8	21125	2	CONTACT BOARD, EAC FILTER

7.4 Baffle Filters and Switches

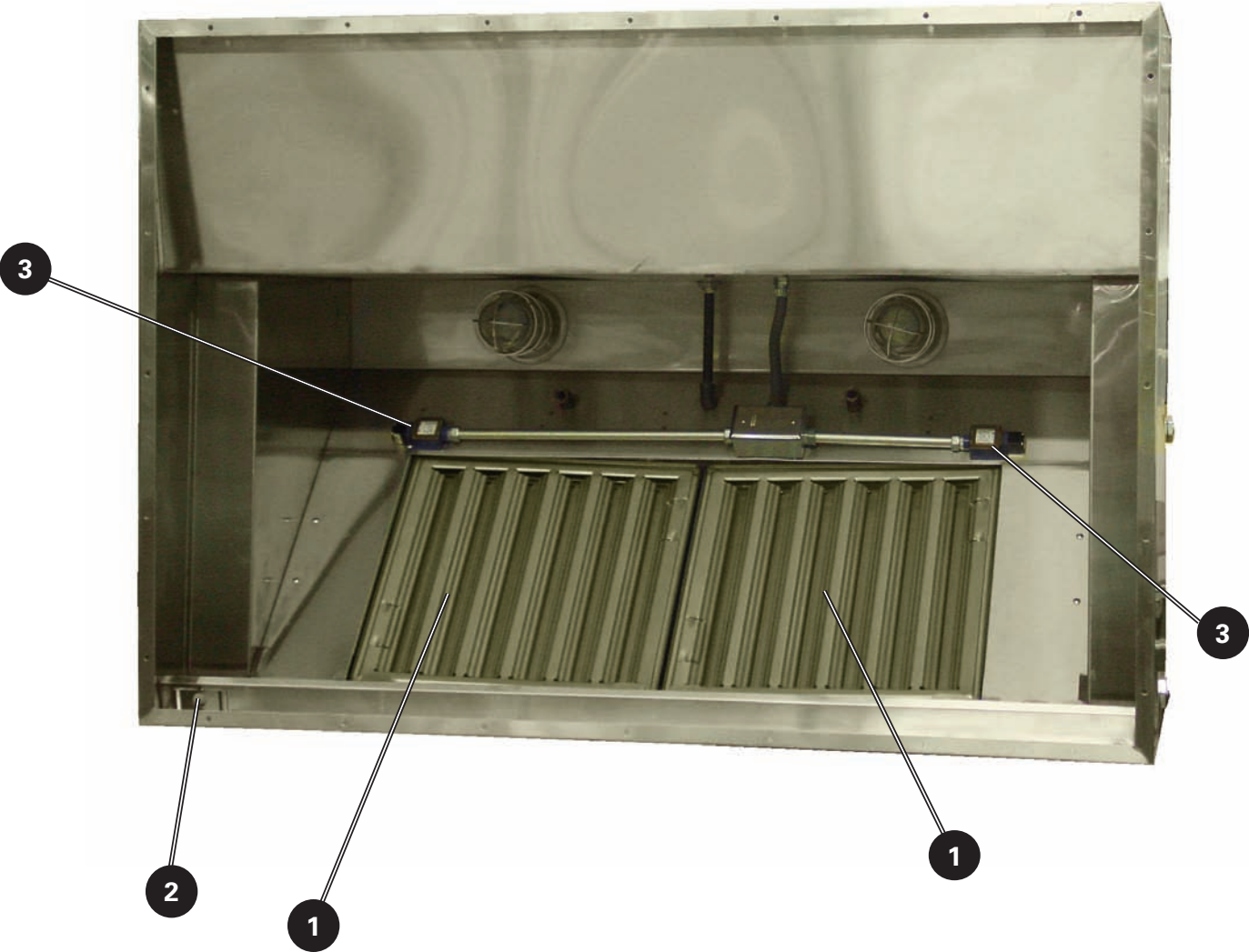



7.4 Parts List for Baffle Filters and Switches

Item	Part No.	Qty.	Description
1	42300	2	BAFFLE FILTER, S/S, 20 X 20
2	32776	1	DRIP CUP
3	32102	2	BAFFLE FILTER SWITCH ASSY

7.5 Doors and Front Panel



7.5 Parts List for Doors and Front Panel

Item	Part No.	Qty.	Description
1	42827	2	DOOR LATCH
2	33637	1	LEFT ACCESS DOOR ASSEMBLY
3	33253	1	RIGHT ACCESS DOOR ASSEMBLY
4	32026	1	HOOD SKIRT, 8-IN, EH-5
4	34231	1	HOOD SKIRT, 8-IN, EH-6
5	31867	1	LEFT SIDE-SKIRT PANEL
6	31868	1	RIGHT SIDE-SKIRT PANEL
7	31885	1	BACK-SPLASH PANEL, EH-5
7	34103	1	BACK-SPLASH PANEL, EH-6

* -Not shown



Giles Enterprises, Inc.

2750 Gunter Park Drive West • Montgomery, Al 36109 USA
Phone: 334.272.1457 • Service Hotline: 800.554.4537 (USA & Canada Only) • FAX: 334.239.4117 • www.gfse.com

Form No. 60073 (Revision Date: 08/25/11, Rev. E)