

## Operation & Service Manual

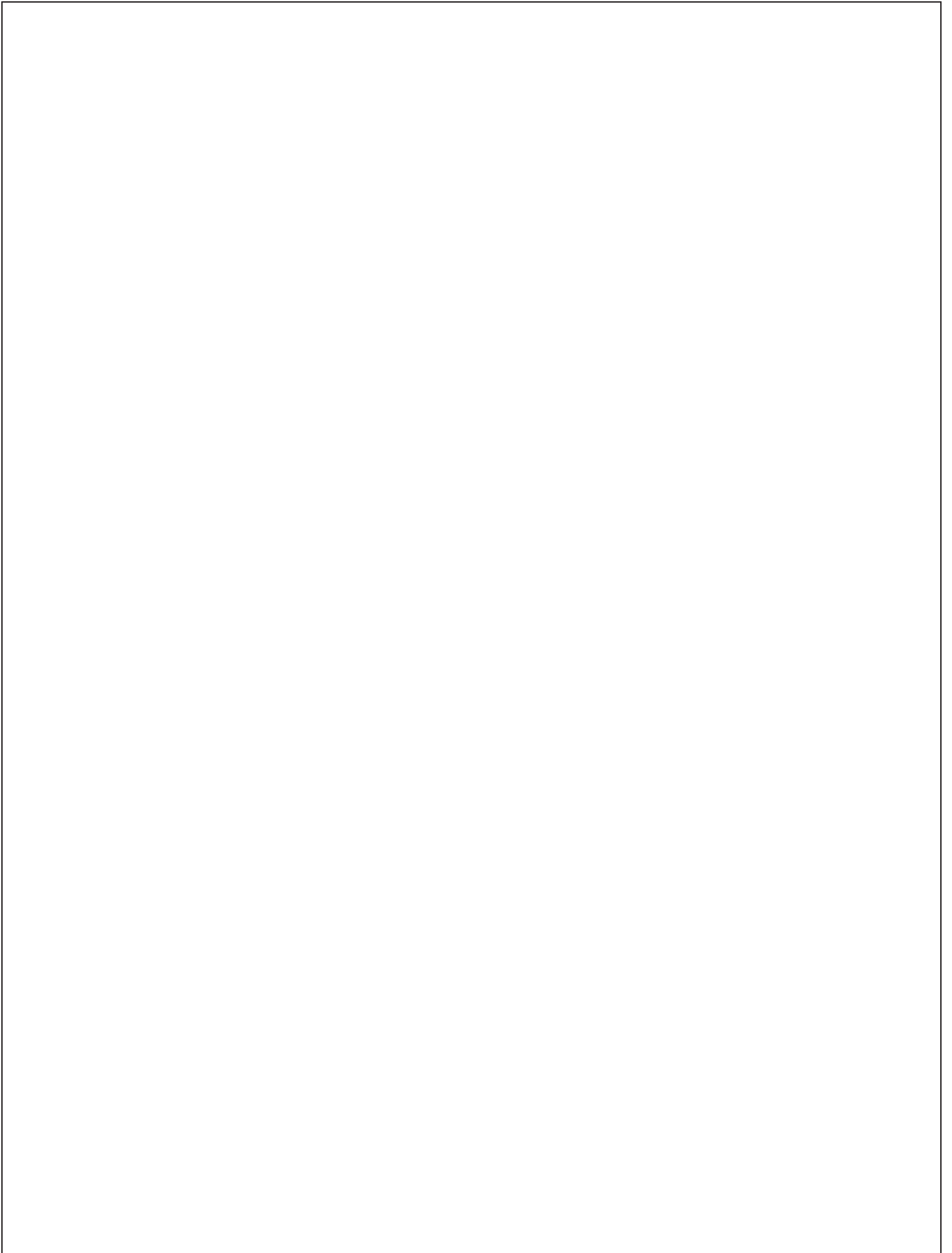

Model FSH-6





## LIMITED WARRANTY

- Subject to the terms and conditions of this Limited Warranty as herein stated, all Giles Enterprises Inc. (hereafter referred to as "Giles") food service equipment and parts purchased new from an authorized Giles representative are warranted as to defects in material or workmanship for a period of twenty-four (24) months from the date of installation, provided, however, that with regard to labor costs in connection with this warranty, see below. All installations must be made by a qualified installing agency in accordance with all applicable codes and/or regulations in the jurisdiction in which installed. Limited warranty coverage is extended only to the original owner and is void if the unit is resold.
- During the Limited Warranty period, Giles will replace or recondition, at its factory, any part or parts of this unit which Giles inspectors judge defective, provided the unit has been properly installed, subjected to normal usage, and operated and maintained in accordance with specified procedures. This Limited Warranty does not cover cosmetic damage, and damage due to acts of God, accident, misuse, alteration, negligence, abuse, or use of unorthodox repair methods. All parts replaced under this Limited Warranty carry only the unexpired term of this Limited Warranty. Limited Warranty service may be furnished only by an authorized Giles service representative.
- If Limited Warranty service is requested, Giles will dispatch factory-authorized service representatives to inspect, repair, recondition, or replace units of its manufacture with such labor being rendered without cost to owner for twenty-four (24) months from the date of installation. Otherwise, service, including labor and transportation charges or other expenses, in connection with the removal or installation of any part or parts supplied under this Limited Warranty, are specified on the original sales contract between the purchaser and the authorized Giles representative.
- **Failure to use Giles OEM replacement parts and Giles OEM filters may void this Warranty.**
- Giles reserves the right to change or improve its equipment and/or parts in any way without obligation to alter such equipment or parts previously manufactured.
- Giles makes no further warranties, express or implied, including implied warranties of merchantability or fitness for a particular purpose, and has no other obligation or liability not specifically stated herein.
- Repair or replacement as provided under this limited warranty is the exclusive remedy. Giles shall not be liable for any incidental or consequential damages for breach of any express or implied warranty on this product, except to the extent prohibited by applicable law. Any implied warranty of merchantability or fitness for a particular purpose on this product is limited in duration to the duration of this limited warranty.
- Used Giles food service equipment or parts, or Giles food service equipment or parts not purchased from an authorized Giles representative, carry no warranties, express or implied.

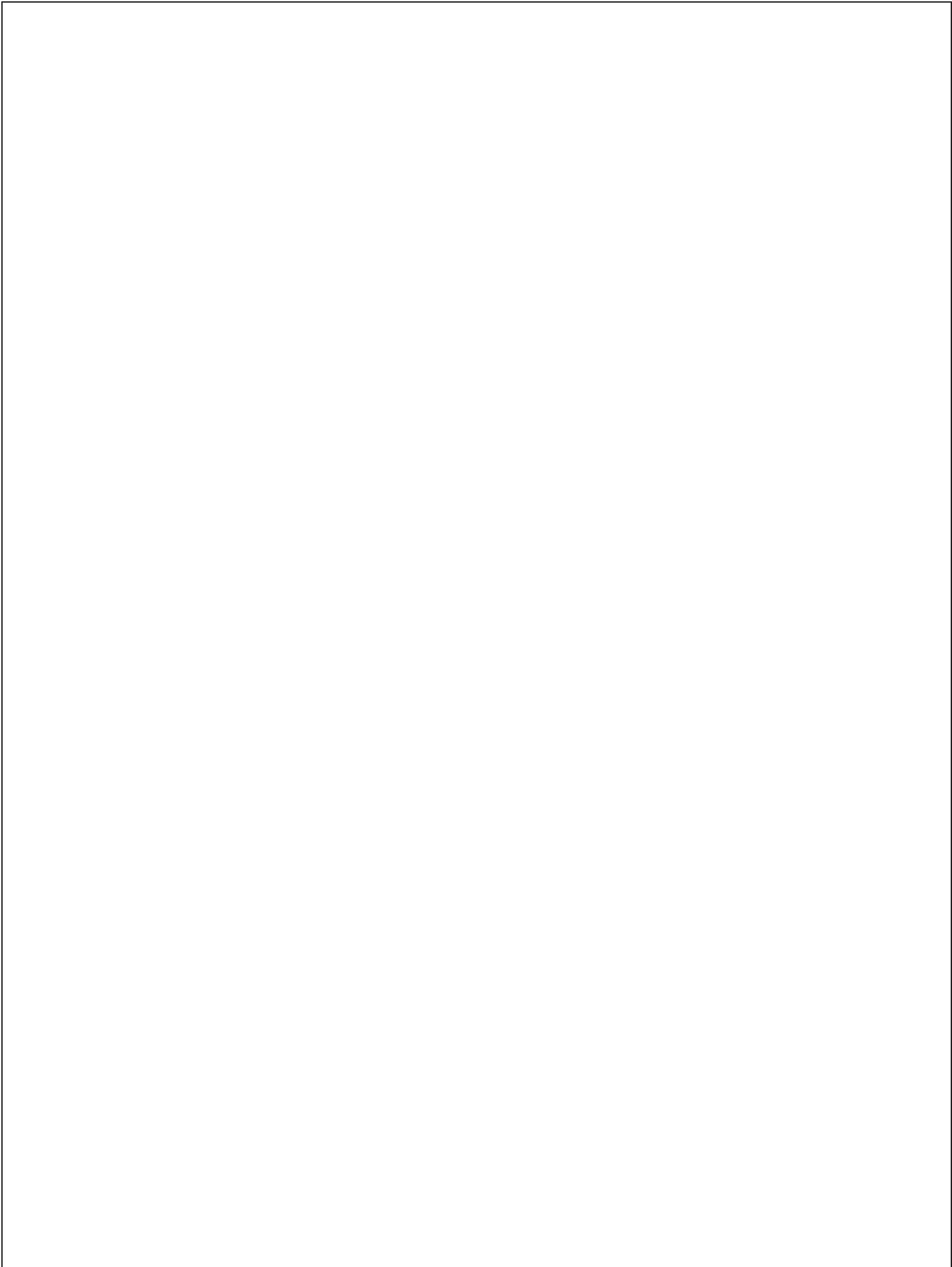

<b>Safety</b>	.....	<b>iii</b>
Safety Overview	.....	iii
Specific Safety Precautions	.....	iv
<b>1. Introduction</b>	.....	<b>1</b>
1.01 Construction	.....	1
1.02 Standard Features	.....	1
1.03 Specifications	.....	2
1.03.1 Overall Dimensions	.....	2
1.03.2 Agency Certifications	.....	3
1.03.3 Hood Weights	.....	3
<b>2. Installation</b>	.....	<b>5</b>
2.01 Location	.....	5
2.02 Unpacking	.....	6
2.03 Hood Installation Details	.....	6
2.03.1 Floor Stand Assembly	.....	7
2.04 Cooking Appliance Limitations & Clearances	.....	8
2.05 Electrical Specifications - Hood Only	.....	9
2.05.1 Electrical Connections	.....	9
2.05.2 Routing Power Conduit & Wiring	.....	10
2.05.3 Hood and Appliance Interlock Diagram	.....	10
2.06 Fire Suppression System Installation	.....	11
2.06.1 Fire Suppression System Connection	.....	11
2.06.2 Fire Suppression Detector Links & Location	.....	12
2.06.3 Appliance Nozzles	.....	12
2.06.4 Fire Extinguisher Nozzle Locations	.....	13
<b>3. Overview</b>	.....	<b>14</b>
3.01 Control Panel	.....	15
3.02 Filter Chamber & Exhaust	.....	17
3.03 Accessories Items Included w/Hood	.....	19
<b>4. Operation &amp; Filter Maintenance</b>	.....	<b>22</b>
4.01 Starting the Hood	.....	22
4.02 Filter System, Filter Maintenance & Filter Alarms	.....	22
4.02.1 Ventless Hood Filter Table	.....	22
4.02.2 Baffle Filter Removal	.....	23
4.02.3 Baffle Filter Installation	.....	24
4.02.4 Pre-Filter Removal	.....	25
4.02.5 Pre-Filter Installation	.....	26
4.02.6 E.A.C. Filter Cell Removal	.....	27
4.02.7 E.A.C. Filter Cell Installation	.....	28
4.02.8 Charcoal Filter Removal	.....	29
4.02.9 Charcoal Filter Installation	.....	30
4.03 Hood Filter Alarms	.....	31
4.03.1 Baffle, Pre-Filter or Charcoal Filter Missing	.....	31
4.03.2 Baffle, Pre-Filter or Charcoal Filter Clogged	.....	31
4.03.3 E.A.C. Filter Status & Alarm	.....	32

4.04	Filter Maintenance . . . . .	33
4.04.1	Baffle Filter Cleaning . . . . .	33
4.04.2	E.A.C. Collector Cell Cleaning . . . . .	33
4.04.3	Pre-Filter Maintenance . . . . .	36
4.04.4	Charcoal Filter Maintenance . . . . .	36
<b>5.</b>	<b>Hood Cleaning and Maintenance . . . . .</b>	<b>37</b>
5.01	Monthly Hood Interlock Inspection . . . . .	37
5.02	Quarterly Hood Cleaning . . . . .	38
5.03	Fire Suppression System Maintenance . . . . .	38
5.03.1	Semi-Annual Fire Suppression Inspection & Maintenance . . . . .	39
5.03.2	Annual Fire Suppression System Inspection & Maintenance . . . . .	39
5.03.3	12-Year Fire Suppression System Inspection & Maintenance . . . . .	39
5.04	Maintenance & Service Log . . . . .	40
<b>6.</b>	<b>Troubleshooting . . . . .</b>	<b>41</b>
6.01	Troubleshooting Procedures . . . . .	41
<b>7.</b>	<b>Parts List . . . . .</b>	<b>44</b>
7.01	Parts Ordering & Service Information . . . . .	44
7.02	Component Drawer & Control Panel . . . . .	45
7.03	Hood Filter Chamber . . . . .	47
7.04	Under Hood Components . . . . .	49
7.05	Hood Front & Floor Stand . . . . .	51

## Safety Overview

The information contained in this manual has been prepared to explain proper procedures for safely installing, operating and maintaining your **Giles Food Service Equipment**.

Throughout the manual, safety precautions are identified by a hazard alert symbol and key words ***DANGER***, ***WARNING*** or ***CAUTION***. Safety information will generally precede the process to which it applies. Suggested, recommended, and other noteworthy information will be identified as ***NOTES***, or noted as ***IMPORTANT!***. Additionally, certain words are used to indicate a specific meaning, or to add emphasis as follows:

- Shall:** understood to be mandatory.
- Should:** understood to be advisory.
- May:** understood to be permissive.
- Will:** indicates a future event or condition to occur.

 **Hazard Alert Symbols** are used in conjunction with notifications, such as ***DANGER***, ***WARNING***, or ***CAUTION***, to alert users to potential personal injury hazards and/or poor operating practices. These notifications will immediately precede precautionary measures relating to avoiding the hazard or practice. Adhere to all of the stated safety precautions to avoid possible injury, even death, damage to the equipment or damaged property. Failure to do so may also void the factory warranty.

 ***This product can minimally expose users to materials containing lead, nickel, aluminum, cadmium, brass, carbon, copper or BPA which are known in the state of California to cause cancer, birth defects and other reproductive harm. For more information go to: [www.p65warnings.ca.gov](http://www.p65warnings.ca.gov).***

### **DANGER**

Indicates an imminently hazardous situation which, if not avoided, will result in serious personal injury, even death.

### **WARNING**

Indicates a potentially hazardous situation which, if not avoided, could result in serious injury, even death.

### **CAUTION**

Indicates a potentially hazardous situation (*or unsafe practice*) which, if not avoided, may result in minor to moderate injury.

### **CAUTION**

Used without the safety alert symbol, indicates a potentially hazardous situation which, if not avoided, may result in equipment damage and/or damage to property, and may void the factory warranty.

### **NOTE or IMPORTANT!**

Identifies suggested, recommended, or other important information.

### Specific Safety Precautions:

For your safety, please observe the following precautions when operating or servicing this *GILES* food service equipment. Adhering to the following important safety information will help to prevent personal injury and/or damage to the equipment.

#### DANGER

- Before cleaning or performing maintenance, place **POWER** switch in the **[OFF]** position. To remove all power from the appliance, unplug power cord or turn OFF breaker in the electrical panel supplying the unit.
- Failure to place **POWER** switch in the **[OFF]** position when replacing filters, could result in equipment damage, electrical shock or other serious personal injury.
- ***DO NOT*** wash down interior or exterior of hood with water spray hose.
- Failure to comply with **DANGER** notices will result in serious injury, even death; or damage to equipment and/or property and may void the factory warranty.

#### WARNING

- Ventless/recirculating hoods are *not* suitable for every commercial food service application. Failure to fully comply with all site requirements and installation limitations as outlined in the *GFSE Hood Approval Letter & this Manual*, may result in poor or highly unsatisfactory hood performance.
- ***DO NOT*** use ventless/recirculating hoods with gas-fired cooking appliances ... a high potential for inhalation hazards from carbon monoxide build-up in the operating space will exist. *Hood is approved ONLY for use with electrically heated appliances.*
- Consult a qualified electrical contractor, or kitchen equipment specialist, to ensure that installation will comply with all electrical requirements & codes, and that breakers and wiring are of sufficient rating and gauge to power this equipment (check the rating label ... a wiring diagram is provided). **The unit must be installed and electrically grounded in accordance with local codes, or in the absence of local codes, in accordance with the National Electrical Code, NFPA 70.** Improper or inadequate grounding may result in electrical shock to users.
- Improper installation, alteration of the unit, or improper service & maintenance could result in serious injury, even death; equipment and/or property damage; and will potentially void the factory warranty.
- ***DO NOT*** use or store flammable liquids, or materials that produce flammable vapors, in the vicinity of this or any other appliance!
- Failure to comply with **WARNING** notices could result in serious injury, even death; damage to equipment and/or property; and will potentially void the factory warranty.

**CAUTION**

- Exercise care when removing wooden crate framework & the unit from shipping pallet. The hood is very heavy ... extreme caution must be exercised when assembling floor stand & lifting the hood to mount atop stand.
- Use extreme caution when moving & positioning an *assembled floor stand unit* into the final location ... it will be very top-heavy. Once located, be sure unit is properly leveled & anchored to floor.
- **DO NOT** operate the appliance unless you understand the function of all components and proper operating procedures (read **Section 3**). Closely follow the instructions in this manual to avoid equipment damage and/or malfunction.
- The equipment is not intended to be used by persons (including children) with reduced physical, sensory, or mental capabilities, or lack of experience and knowledge, unless they have been given adequate instruction and/or supervision concerning use by a person responsible for their safety.
- When working in a kitchen environment, take necessary precautions to avoid injury due to **HOT** surfaces (*cooking appliances, utensils, tools, etc.*). As applicable, always wear thermal protection, such as oven mitts or gloves, when handling hot pans, utensils or foods.
- Failure to comply with **CAUTION** notices may result in minor to moderate personal injury, damage to equipment or property, and potentially void the warranty.

**CAUTION**

- Some components & controls are impact-sensitive. To avoid damage and maintain proper operation, exercise due care when working near the hood.
- Handle the *electronic air cleaner (E.A.C.) collector cell* carefully. **DO NOT** bend the collection plates (*fins*) or break the fine wires stretched across the cell face ... result will be to significantly reduce the performance of the air cleaning system and can eventually result in shutdown of power to cooking appliances under hood.
- After cleaning the cell, **DO NOT** attempt to dry it by installing in hood & running. **NEVER PLACE A WET CELL INTO HOOD ... can potentially damage the system and cause improper operation. Such damage is NOT cover by the factory warranty.** If desired, drying after cleaning can be expedited by setting a small electric fan to blow room air across the cell.
- When cleaning this equipment:
  - **DO NOT** steam clean.
  - **DO NOT** clean with products containing chlorine, or other corrosive chemicals.
  - **DO NOT** use abrasive products, steel wool or scouring pads.
  - **DO NOT** use oven cleaner products.
- **DO NOT** alter, add attachments, or otherwise modify the equipment! **DO NOT** attach any type of ductwork extensions to the hood exhaust in an attempt to redirect the exhaust airflow.
- Failure to comply with **CAUTION** notices may result in damage to equipment or property. Such damages are **NOT** covered by the factory warranty.

**NOTE:**

- Comply with all appropriate state and/or local health regulations regarding cleaning and sanitation of food service equipment.
- To clean difficult surface areas, having excessive grease residue build-up, *GILES* recommends using a mild, biodegradable, non-toxic degreasing cleaner such as ***Simple Green® Crystal Foaming Spray Cleaner/Degreaser***.
- *GILES* assumes no responsibility with regard to code compliance during installation or when using ventless recirculating ventilation equipment. The customer shall be responsible for obtaining all necessary approvals from ***Authorities Having Jurisdiction (AHJ)*** before installation & operation.

## 1. Introduction

**THANK YOU** for purchasing a **Giles Model FSH-6 Ventless Recirculating Hood**, manufactured by *Giles Enterprises, Inc.*, Montgomery, Alabama (USA), hereafter referred to as "**GILES**". Giles ventless technology is the result of extensive engineering, research and development. Every unit is thoroughly inspected and tested prior to shipment to ensure it operates flawlessly after installation. With proper care and maintenance this unit should provide years of trouble-free service.

The *standard* hood is mounted on a 72" *high*, self-supporting floor stand.

To help protect your investment, we recommend that you take the time to review this *Manual* and become familiar with the procedures pertaining to installation, operation, cleaning and maintenance. Adherence to these recommended procedures will minimize potential for costly equipment downtime & future repair expenses.

***Please retain this Manual for future reference.***

### 1.01 Construction

Constructed of high-grade stainless steel sheet metal.

### 1.02 Standard Features

#### **Control Panel:**

- LED indicator lights show the operational status for each of the two (2) Electronic Air Cleaner collector cells.
- Indicator lights display hood performance status & provide signals when operator attention is required to correct conditions negatively affecting hood performance ... *missing filters, misaligned filters, clogged filters, airflow obstructions, etc.*
- **APPLIANCE POWERED** light indicates that cooking appliances under hood are being supplied with power.

#### **Filters:**

- (2) Baffle Filters - captures & removes the largest grease particulate from cooking vapor.
- (2) Pre-Filters - captures & removes smaller particulate and helps remove moisture.
- (2) Electronic Air Cleaner (E.A.C.) Collector Cells - electrostatically capture fine particle air contaminants.
- (2) Charcoal Filters - help to control undesirable cooking aromas in the exhaust air.

#### **Push-To-Start Power:**

After a power interruption, neither the hood nor interlocked cooking appliances underneath will automatically restart when power is restored ... hood **POWER** switch must be pressed for restart. Once hood restarts, power is then supplied to the cooking appliances. Features complies with code requirement, where applicable.

#### **Pre-plumbed for Fire Suppression System:**

Factory pre-plumbed for connection to a listed fire suppression system ... **Ansul® R-102 wet chemical**. Includes piping, plenum nozzles (**no appliance drop-downs**), detector link brackets and conduit. **The Ansul system, field installation, set-up, testing & final commissioning shall be provided by the purchaser, and must be supplied by an authorized Ansul® Distributor/Dealer ... not included with purchase.**

## 1.03 Specifications

### 1.03.1 Overall Dimensions

Code	Dimension
[A]	72-9/16 [1843]
[B]	68-7/16 [1738]
[C]	73-3/4 [1873]
[D]	72 [1829]
[E]	117 - 3/16 [2977]

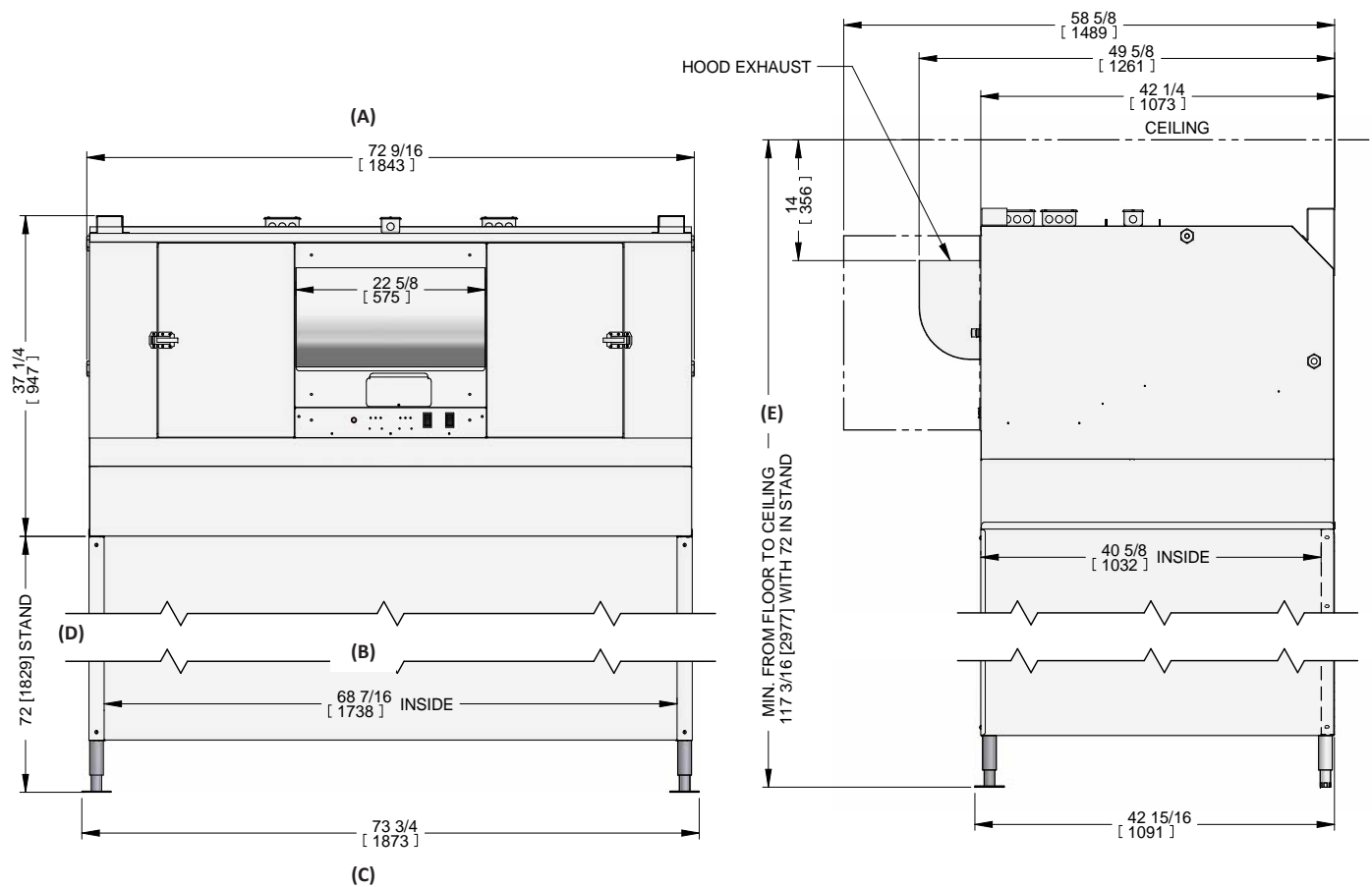

INCHES [mm]

## 1.03.2 Agency Certifications



## 1.03.3 Hood Weight

Hood Model	Crated Weight	Uncrated Weight (approx.)
FSH-6	925 lbs [420 kg]	725 lbs [329 kg]



## 2. Installation

This section summarizes procedures for proper equipment installation. To help avoid personal injury or damage to the equipment or property, be sure to follow all of these recommended procedures.

**Installation expense (materials & labor) is the sole responsibility of the purchaser.** Generally, it is advisable to engage the services of professional commercial kitchen equipment specialists, licensed electricians, and/or qualified HVAC contractors to assist with the details of installation. Call *Giles Technical Support @ 800.554.4537*, if assistance is required.

The hood is factory-assembled with internal fire suppression components (*piping, nozzles, detector link brackets, cable conduit, exhaust fire damper*) and is ready to be connected to a, **customer provided**, fire suppression system specified by the UL listing ... **Ansul® R-102 Wet Chemical System**. The system field installation, set-up, testing and final commissioning shall be provided for by the purchaser, and must be supplied by an authorized **Ansul Distributor/Dealer**.

### 2.01 Location

#### IMPORTANT!!

Before installing a **GILES Recirculating/Ventless Hood system** ensure that ... A). All necessary approvals have been obtained from local code authorities ... B). The appliances to be placed under the hood are all within the hood's listing limitations, as outlined in **Section 2.04** ... C). The installation site complies with the specific requirements & limitations outlined in the **GFSE Recirculating/Ventless Hood Approval Letter (HAL)**. The **HAL is available for review & download at [www.gfse.com](http://www.gfse.com) on the SUPPORT menu under VENTLESS DOCUMENTS.**

To ensure satisfactory hood performance when installed, the intended site **MUST** comply with minimum requirements for **kitchen size (>600 sq ft), ceiling height**, fresh outdoor air make-up, room air exchange rate, supplemental exhaust ventilation, clearances, etc. as stipulated in **Giles Hood Approval Letter**.

- **MAXIMUM** of 1 hood per 600 sq ft of commercial kitchen space.
- Fresh outside air make-up must be equal to a **MINIMUM of fifteen (15)** complete room air exchanges per hour.
- Giles makes no representations as to the proper layout design for an establishment in which the ventless hood will be used. Further, Giles does not perform site inspections prior to installation of its units.
- The hood produces a sound level of approximately **75 dB** when in operation.

#### CAUTION

- **DO NOT ALTER, ADD ATTACHMENTS OR OTHERWISE MODIFY THIS EQUIPMENT.**
- **Failure to comply with installation requirements as specified by the Giles Hood Approval Letter will void the factory warranty.**

1. A minimum clearance of **14" (355.6 mm)** must be maintained between the top of the hood exhaust outlet and ceiling, or other large overhead obstructions ... **approx. 10" (254 mm) above the hood top. If a floor-stand version hood will not meet this requirement, then continuing with the installation is not advisable.**
2. **DO NOT** attach additional ductwork to the exhaust outlet in an attempt to redirect airflow. The back-pressure created can significantly reduce hood capture and result in unsatisfactory performance. **DO NOT** attempt to by-pass the ceiling clearance requirement by directing exhaust air into a ceiling niche, or the space above a suspended ceiling. These actions are considered as improper installations and can void the factory warranty.

## 2.02 Unpacking

### !! IMPORTANT NOTE:

If there is evidence of damage to the palletized unit, or any of the accompanying items, immediately and thoroughly inspect the unit and all components. Notify the freight company of all damages. Generally, it is the responsibility of the customer to file and negotiate freight damage claims with the carrier.

Unit is shipped on a wooden pallet, secured by high-tensile plastic strapping & wrapped in machine-applied stretch film. In most cases a wooden crating framework is built around the unit for added protection. Unpack as follows:

1. Position pallet in an area that provides adequate work space.
2. Remove the plastic stretch wrap, strapping and any other packaging materials.
3. Using suitable equipment or sufficient manpower & safe work practices, carefully remove the hood stand components (*sides, back panels, trim pieces & appliance channels*) from the load & stage them for assembly and installation.
4. Generally, the two (2) stainless baffle filters are placed on top of the hood for shipment. If so, secure them & place for safe place for future installation.
5. Carefully remove any wooden supports and crating framework that might be attached.
6. Locate & secure the envelope containing *Warranty Card* and any other documentation or hardware provided for installation.
7. It is preferable to leave the hood unit on the pallet so that handling equipment can be used to easily move it for final installation.

### CAUTION

- Unit is very heavy and bulky! Use suitable equipment and sufficient manpower to lift and handle the hood. See **Section 1.03.3, Weights**.
- Take care when removing and disposing of packaging materials.
- When moving & handling the hood, take special care not damage the bottom skirting. Dragging unit along the floor or lifting by using the bottom edge has the potential to damage the skirt.
- Failure to comply with these **CAUTION** notices may result in moderate to minor injury, equipment or property damage, and could void the warranty.

## 2.03 Hood Installation Details

### NOTE:

*Items needed for hood installations, selected fasteners & high-temp silicone, are provided. All other expenses for materials, labor, handling equipment rentals, etc. are the sole responsibility of the purchaser & not included with purchase of a Giles hood.*

## 2.03.1 Floor Stand Assembly

Assemble stand with provided hardware & fasteners ... mount hood as shown below. Apply high-temp silicone as shown during assembly.

### STEP 1

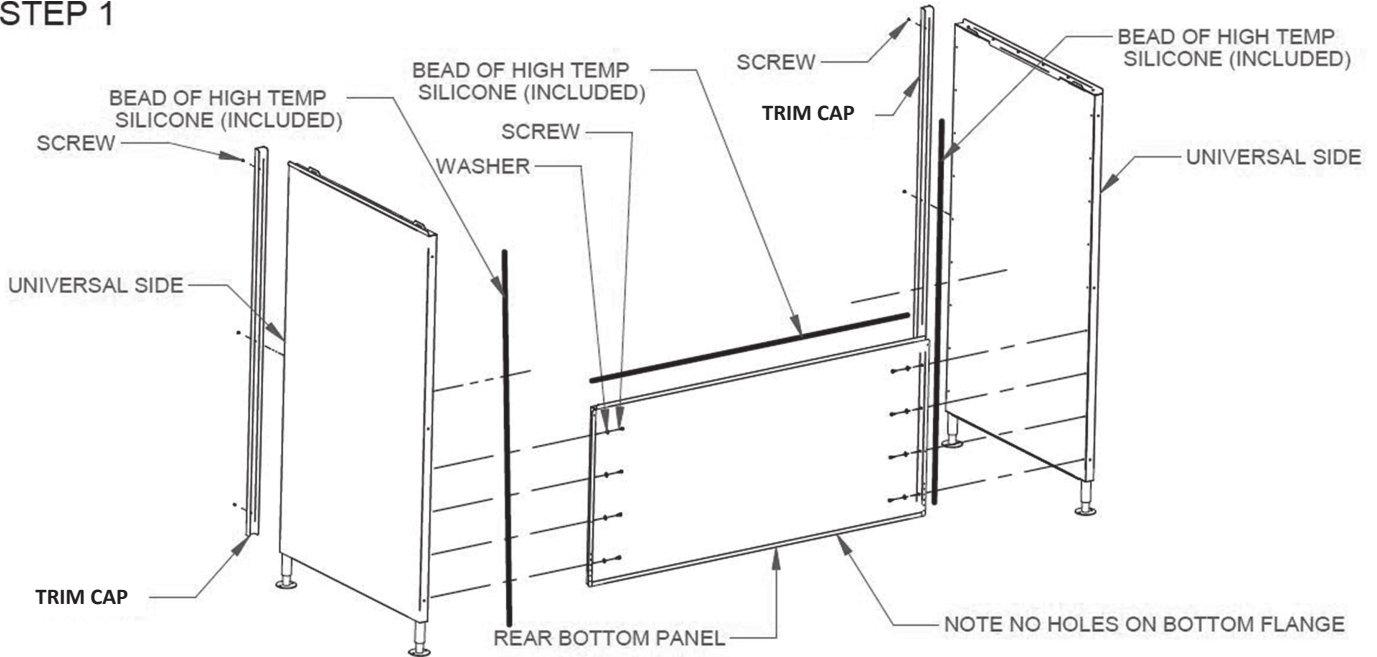

### STEP 2

Install upper back panel.

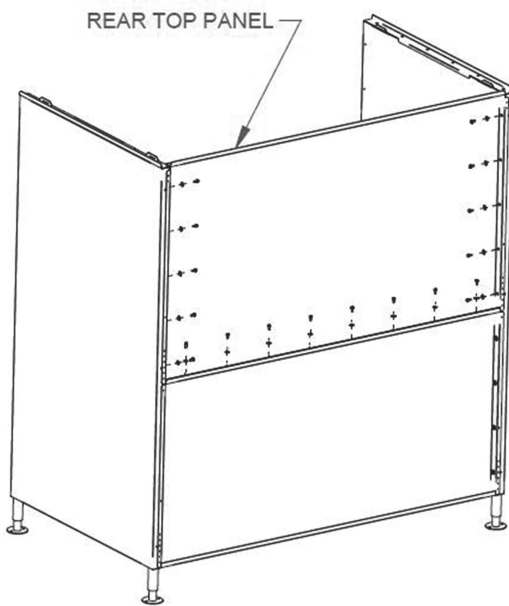

### STEP 3

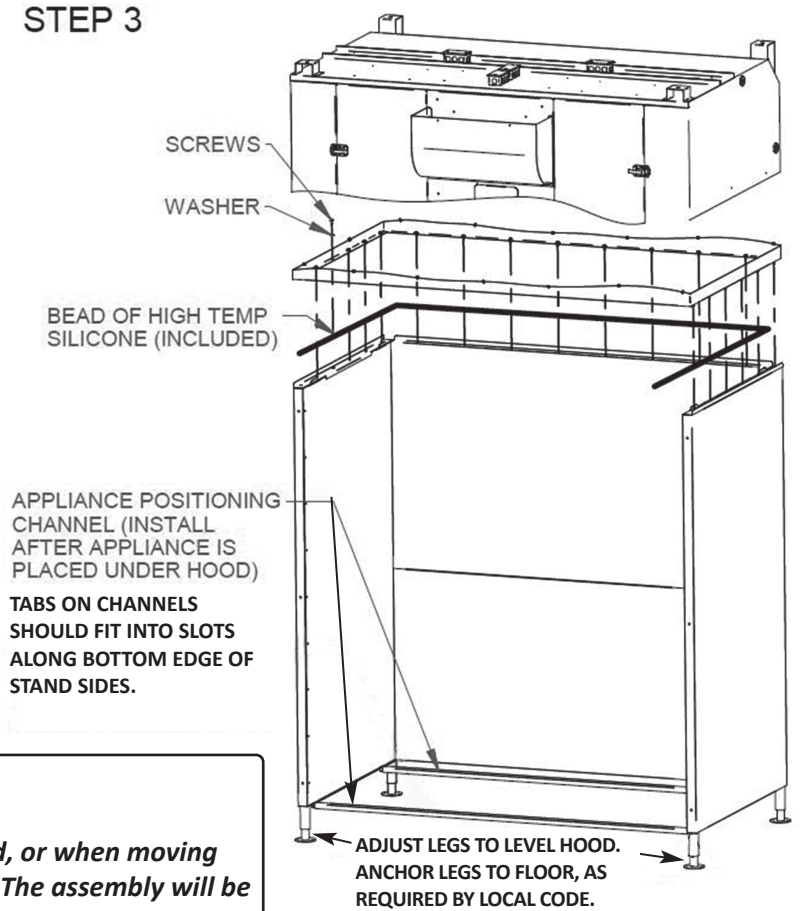

### **CAUTION**

Use extreme care when mounting hood onto stand, or when moving the assembled hood & stand into a final location. The assembly will be very heavy & extremely top-heavy.

## 2.04 Cooking Appliance Limitations & Clearances

**HOOD APPROVED FOR ELECTRICALLY HEATED APPLIANCES ONLY.**

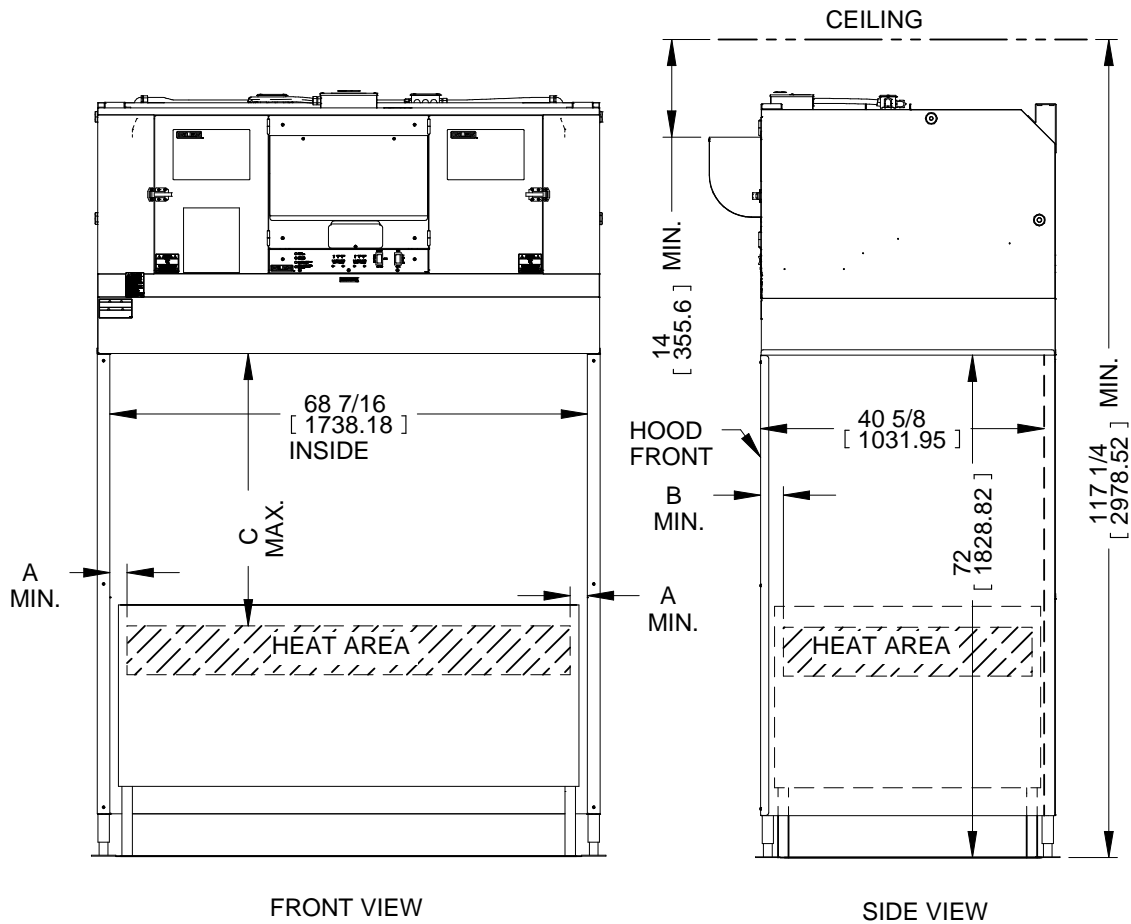

APPLIANCE RESTRICTIONS							
APPLIANCE	A	B	C	MAX INPUT POWER (kW)	MAX COOKING TEMP	MAX SHORTENING CAPACITY	MAX COOKING AREA
FRYERS	0	15.5	42	40 (Total) or 20 (per Fryer)	350°F [177°C]	160 lbs [72kg] (Total) 80 lbs [36kg] (per Fryer)	380 sq.in [0.25 sq m] single fryer 760 sq in [0.49 sq m] any combination
OVENS	0	0	42	55	500°F [260°C]	N/A	68"[1727 mm] W x 42" [1067 mm] D
GRIDDLES	0	15	42	25	400°F [204°C]	N/A	60"[1524 mm] W x 26"[660 mm] D
RANGES	0	15	42	25 Max 8 Burners	400°F [204°C]	N/A	60"[1524 mm] W x 26"[660 mm] D
*BROILERS (Vertical/Horizontal) *not for use with Charbroilers	0	15	42	25	500°F [260°C]	N/A	60"[1524 mm] W x 26"[660 mm] D 42"[1067mm] max (appl top to hood btm)

## 2.05 Electrical Specifications - Hood ONLY

### **⚠ WARNING**

- Food service equipment must be properly grounded in **accordance with local code, or in the absence of local code, with the *National Electrical Code, ANSI/NFPA 70***. Improper grounding may result in electrical shock to users. Check local electrical code to ensure that proper grounding is applied.
- Always consult a certified electrician, or other qualified service technician, prior to installation to ensure that electrical circuits are of sufficient rating for the hood and appliance load.
- **Improper installation, adjustment, alteration, service or maintenance could result in serious injury or possible death, equipment or property damage, and could void the warranty.**

Electrical Specifications (Hood Only)				
Voltage	Hz	Phase	Amps	Breaker
208-240	60	1	8	10

### **IMPORTANT!**

- Hood is designed to operate with either 208V or 240V supply power.
- Breaker size shown applies to *hood power only*. Under-hood appliances are to be powered by a separate circuit with an interlock relay controlled through the hood circuitry, such that the appliances do receive power unless the hood is running properly.

### 2.05.1 Electrical Connections

1. Install appropriate circuit breaker in main electrical panel, see **Section 2.05, Electrical Specifications**.
2. As required by code, route suitable sized flexible conduit from main panel to service box on hood top and attach using appropriate connectors. See **Section 2.05.2, Routing Conduit & Wiring**.
3. Pull appropriately sized wire from the electrical panel to the hood service box. Securely connect power supply wires to the proper terminal blocks inside the service box & reinstall cover.
4. Turn ON breaker supplying power to the hood.
5. Press & briefly hold in the top **[START]** portion of the **POWER** switch, then release when the hood fan starts running. Switch will spring back and remain in the **[ON]** position. The green **[POWER]** light turns ON ... an alarm may briefly sound until the fan reaches full speed. The amber **[APPLIANCE POWERED]** turns ON.
6. Place **POWER** switch in the **[OFF]** position & continue installation.
7. **Section 2.05.3** shows detail for connecting the appliance power supply through a hood interlocked relay.

## 2.05.2 Routing Power Conduit & Wiring

1. This diagram shows a typical conduit & wiring setup for connecting hood and appliance power.
2. See **Section 2.05.3, Hood & Appliance Interlock Diagram** for details on setting up an interlock circuit for the under-hood cooking appliances.

Once properly connected, the appliances should not receive service power unless the hood is running properly.

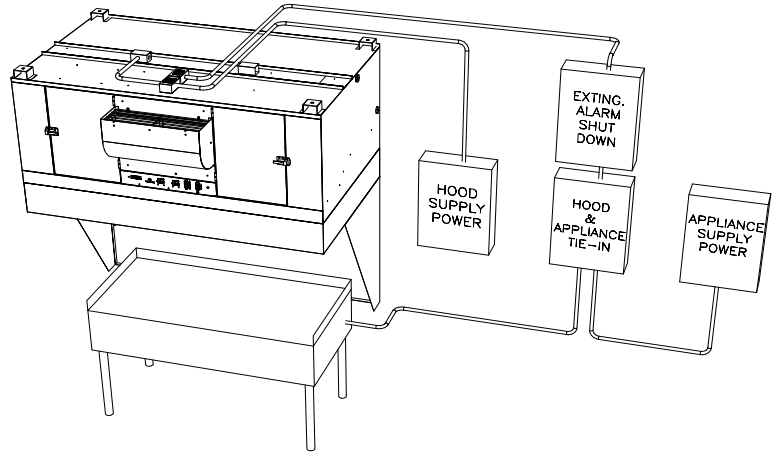

## 2.05.3 Hood & Appliance Interlock Diagram

**IMPORTANT!**  
 Failure to interlock cooking appliances with the hood, so that they are not powered unless the hood is operating, **will not be compliant with the hood's UL listing** and may be in violation of local codes (*building, fire & health*). A typical interlock circuit for under-hood cooking appliances is shown below.

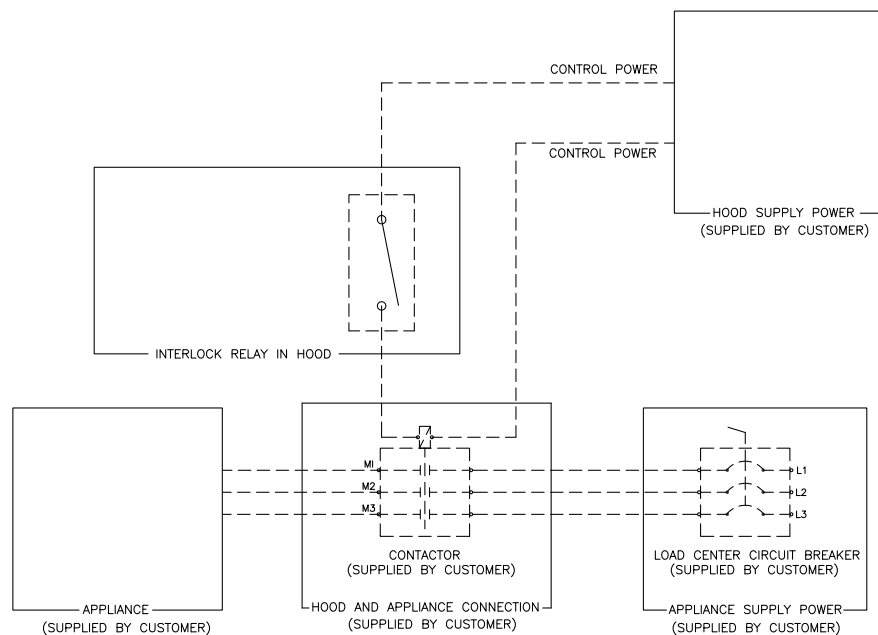

## 2.06 Fire Suppression System Installation

Giles ventless hoods (*plus under-hood cooking appliances*) must be protected by an **Ansul® R-102 Restaurant Fire Suppression System**. Hood includes factory-installed piping, plenum discharge nozzles (*appliance drop-down nozzles not included*), detector link brackets, and cable conduit. Piping & conduit are stubbed out on either side of hood to connect the fire suppression system. **Procurement of the Ansul system, field installation, set-up, testing & certification is the sole responsibility of the purchaser (NOT included with hood).** The system & installation must be provided by an authorized Ansul® distributor/dealer.

1. Ansul 1-W appliance nozzles shall be positioned 11" [279.4 mm] below the lowermost front edge of the hood.
2. Both appliance nozzles must be installed & remain in place at all times.
3. A manual activation station for the fire system (*NOT included*) shall be installed in a conspicuous location in a path of egress (exit) from the area. The pull station must be clearly marked & easily accessible.
4. The regulated *release mechanism* shall be the mechanical type (*Ansul® Automan #79290*) ... 3-gal wet-chemical suppressant storage tank shall be included.
5. Installation, operation & maintenance of this hood must comply with the **Standard for Ventilation Control & Fire Protection of Commercial Cooking Operations, NFPA 96**.

### 2.06.1 Fire Suppression System Connection

**NOTE:** Suppression system may be connected on either left or right side of hood. Connection & set-up of the system must be performed and certified by an authorized Ansul service company.

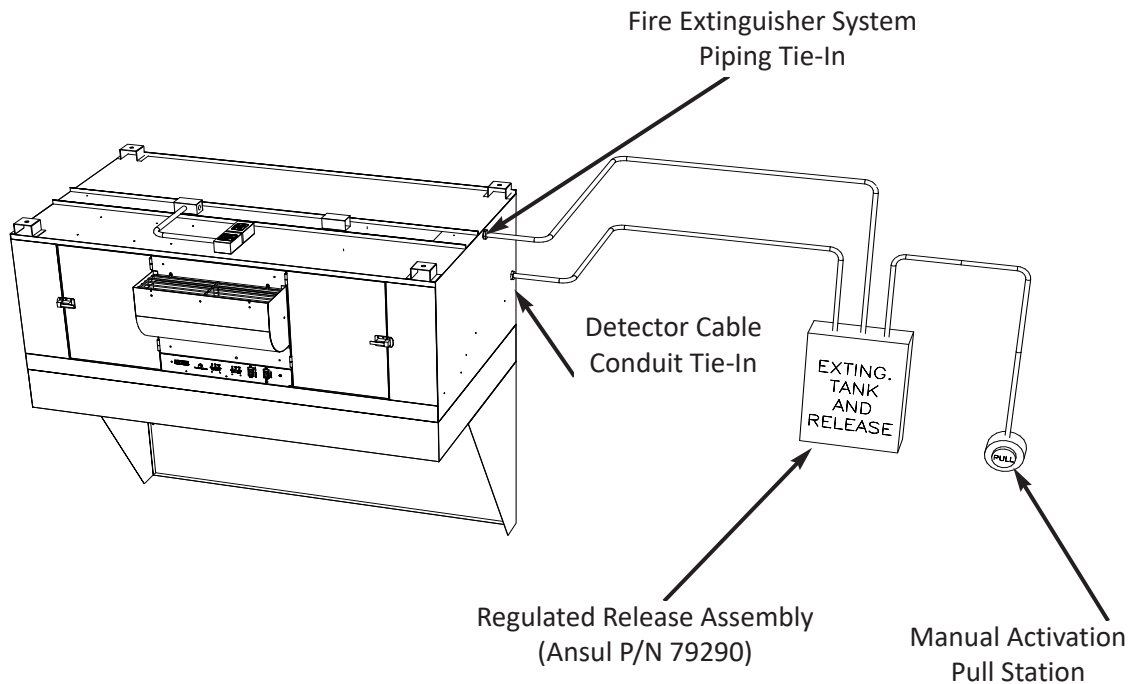

**NOTE:** System can be connected at either side of the hood.

## 2.06.2 Fire Suppression Fusible Detector Links & Location

All fusible detector links shall be supplied & installed by authorized Ansul® service technicians.

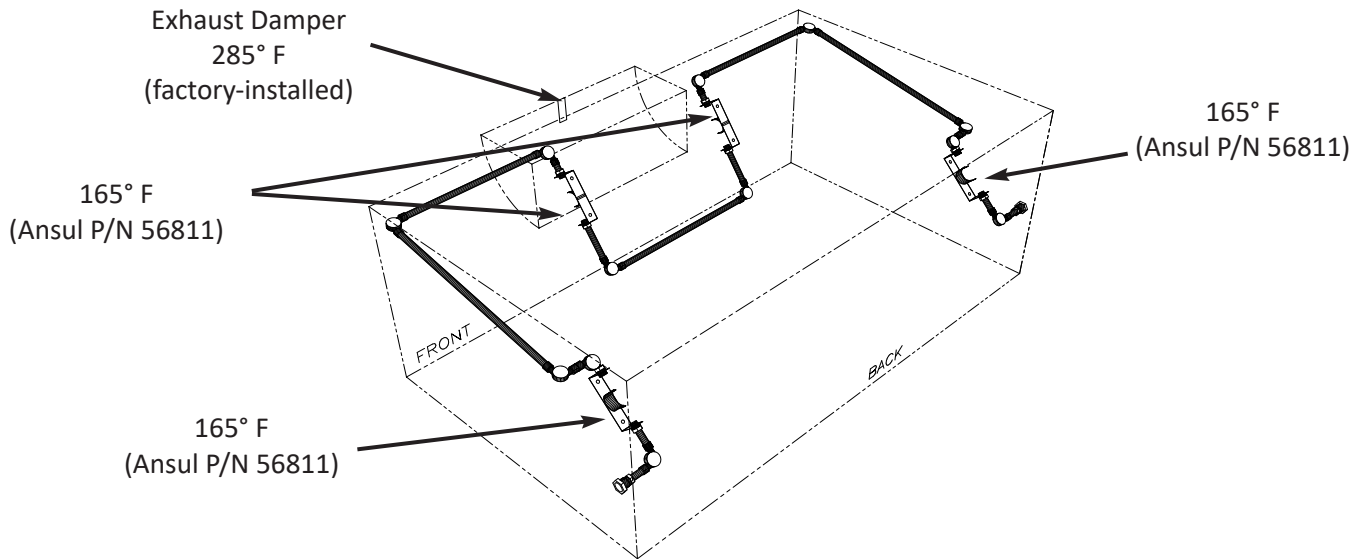

## 2.06.3 Appliance Nozzles

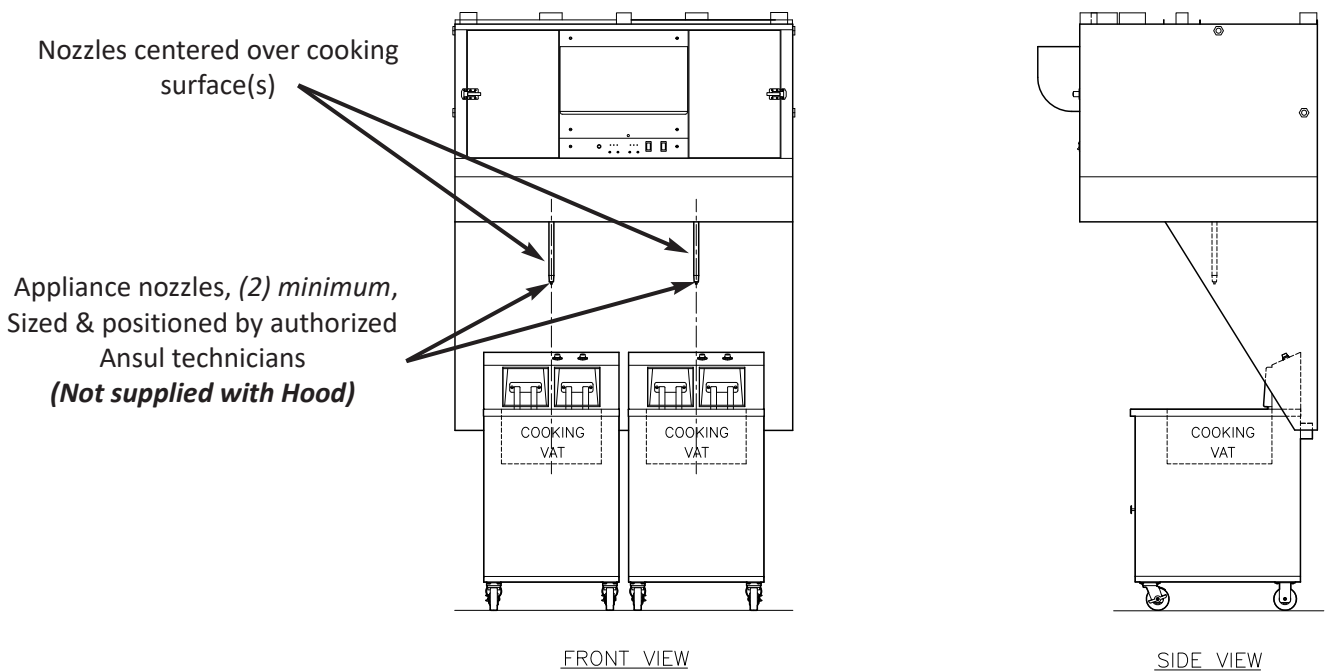

## 2.06.4 Fire Extinguisher Nozzle Locations

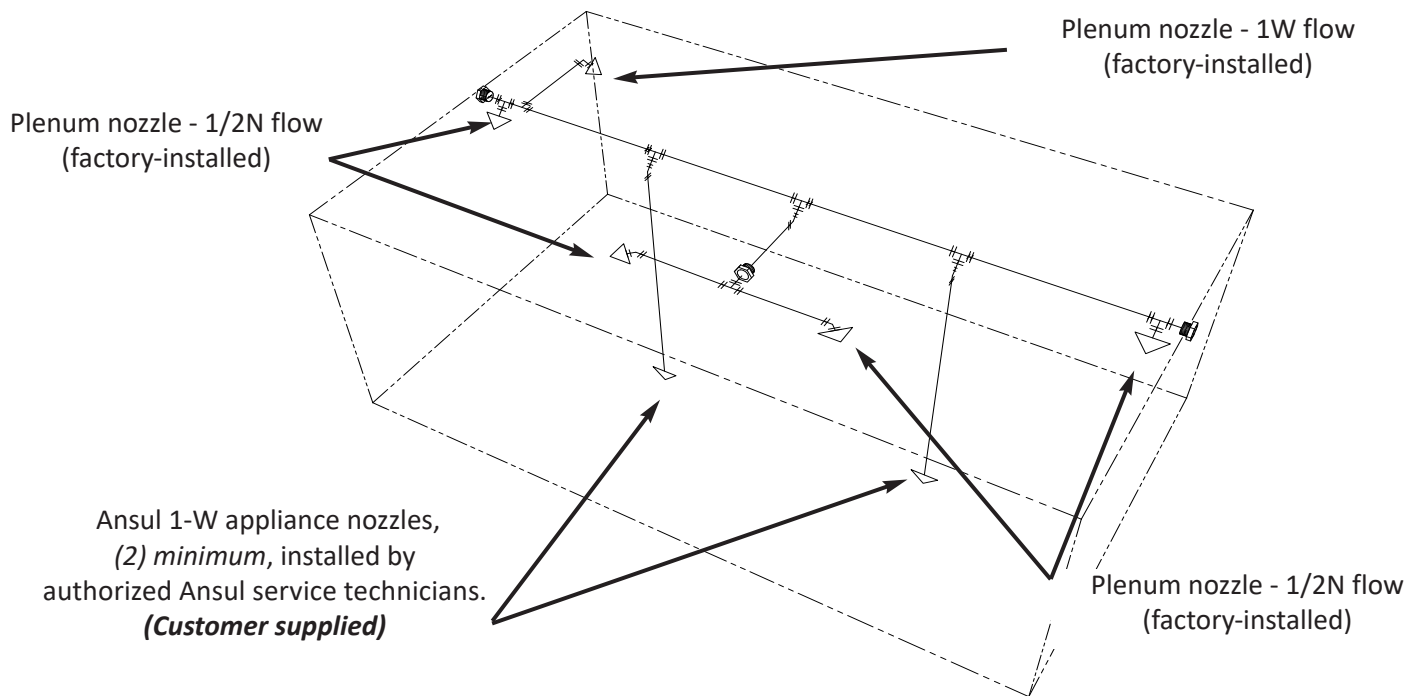

## 3. Overview

This section provides a brief overview of hood components, functions and accessories. Please review carefully before attempting to operate the hood.

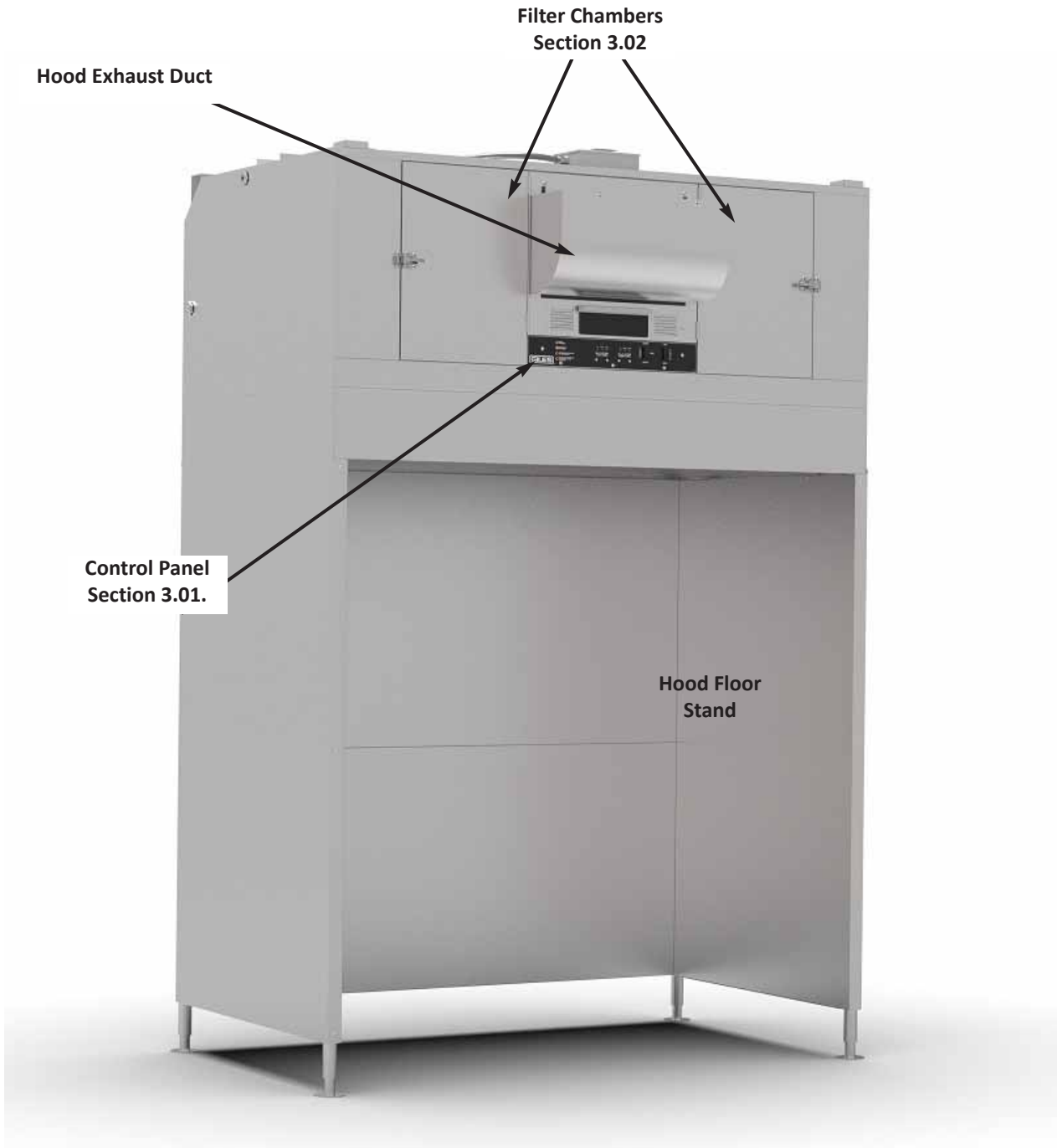

3.01 Control Panel

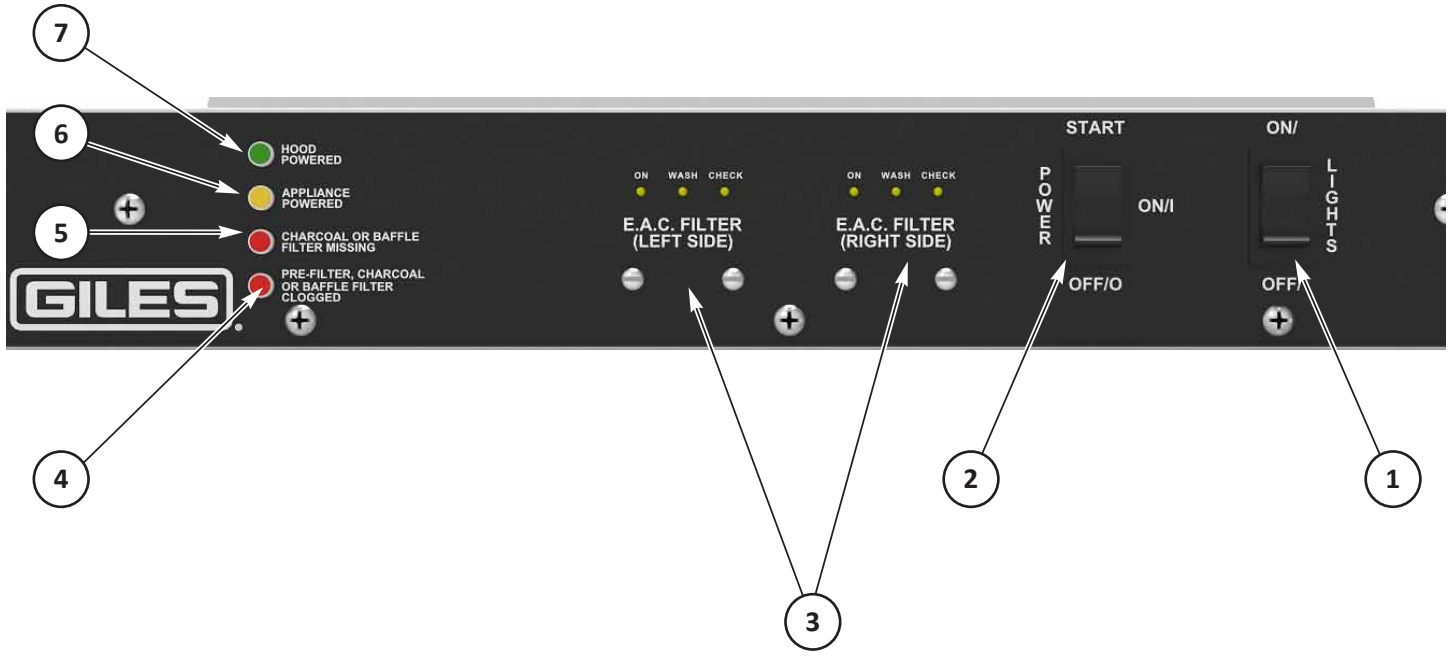

3.01 Control Panel - continued

Item	Description	Function
1	<b>LIGHT</b> Switch	Controls under-hood lighting.
2	<b>POWER Switch (Push-To-Start)</b>	Press & momentarily hold the top <b>[START]</b> portion of switch to start hood & supply power to cooking appliances underneath. Switch remains in <b>[ON]</b> position (center) when released. To turn hood OFF & shutdown power supply to appliances, press the bottom of switch. Hood must be restarted with this switch after any interruption of power supply.
3	E.A.C. Filter Status Indicators	LED lights indicate the status of the electronic air cleaner (E.A.C.) on each side of the hood. <b>[ON]</b> - illuminates when hood is powered & indicates that E.A.C. system is powered & functioning normally to clean air. Should be the only light ON when operating normally. <b>[WASH]</b> - turns ON to indicate excessive build-up on collector fins (dirty), collector cell missing, poor contact, missing ionizer wires, etc. Approximately 2 minutes after this light turns ON, a beeping alarm will begin sounding & power to cooking appliances is shutdown. <b>IMPORTANT! Do not rely on this light as a signal for routine cleaning; cell must be cleaned daily to maintain peak performance &amp; extend the useful life of charcoal filters.</b> <b>[CHECK]</b> - indicates that collector cell has stopped operating ... damaged, shorted to ground, fins shorted due to excessive moisture, etc. No alarm sounds & the cooking appliances remain powered, but air cleaning system is not functioning. <b><u>DO NOT continue operation ... check system &amp; determine cause.</u></b> Service may be required.
4	<b>CLOGGED FILTER</b> Light	Turns ON if filters ( <i>baffle, pre-filter, charcoal filter</i> ) are excessively dirty and restricting airflow through hood. Other obstructions can also be cause ... blocked exhaust, etc. A constant (steady) alarm will sound.
5	<b>FILTER MISSING</b> Light	Turns ON to indicate that a required filter ( <i>baffle, pre-filter, charcoal</i> ) is missing or installed improperly. There will be no alarm sounding.
6	<b>APPLIANCE POWERED</b> Light	Turns ON to indicate that power is being supplied to cooking appliances under hood. When light turns OFF while the hood is powered, there is typically a an alarm condition that has disabled appliance power.alarm condition that has disabled appliance power.
7	<b>HOOD POWERED</b> Light	Turns ON indicating the hood is powered.

3.02 Filter Chamber & Exhaust

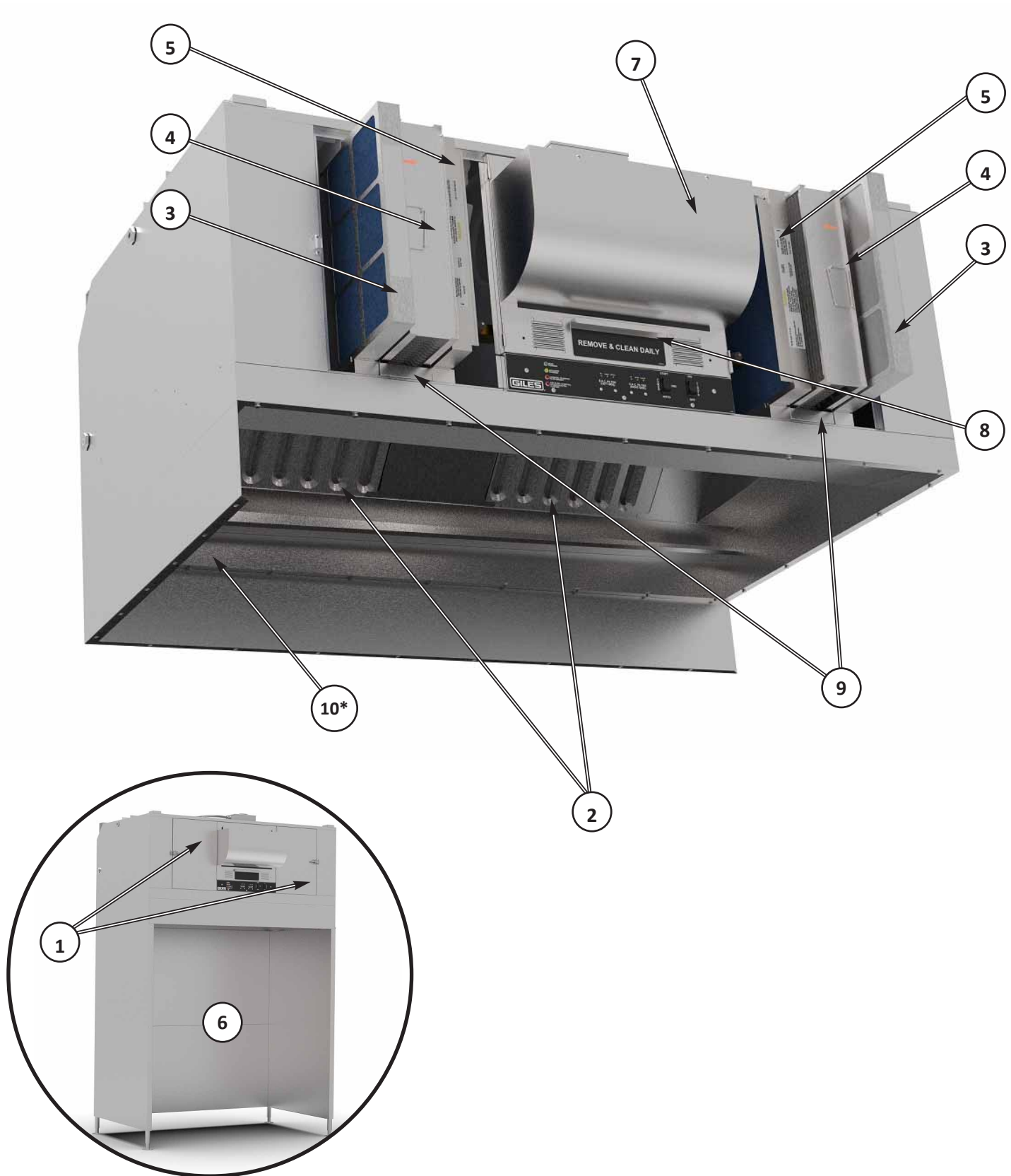



\*Hidden

3.02 Filter Chamber & Exhaust



Item	Description	Function
1	Hood Filter Doors (2)	Provides access the pre-filters, EAC collector cells and charcoal filters. Both doors must be closed & latched before hood will operate.
2	Baffle Filter (2)	First stage of the ventless air cleaning system. Stainless steel filters capture largest grease particulate in cooking vapor. Easy to remove for daily cleaning. <b>Baffle filters should be cleaned daily &amp; can be washed in a dishwasher.</b>
3	Pre-Filter (2)	Single-use, disposable filters ... removes moisture & some smaller grease particulate from the air stream. Helps keep the EAC cells performing effectively. <b>NEVER attempt to clean &amp; re-use pre-filters ... replace every 7-10 days with fresh new filters.</b>
4	E.A.C. Collector Cell (Left & Right)	EAC collector cells are sustainable electrostatic devices that remove fine grease particulate and smoke generated by the cooking appliances. <b>To maintain peak performance, cells must be cleaned <u>DAILY</u> as described later in this manual.</b>
5	Charcoal Filter (2)	Single-use, disposable filters that help to control cooking aromas in exhausted air. Filters must be replaced periodically. <b>NEVER attempt to clean &amp; re-use charcoal filters ... Typically, replace with fresh new filters every 30 to 45 days. Actual replacement frequency is highly dependent on cooking appliances in use &amp; type of foods cooked.</b>
6	Floor Stand	<u>Self-Supporting Floor Stand version</u> hood ... full floor stand fully supports hood & helps contain cooking vapors & improve hood capture performance. Maximizes usable hood width.
7	Exhaust Outlet	Directs cleaned air back into the room. <b>A minimum clearance of 14" MUST be maintained between the top of the exhaust outlet and the ceiling, or other large overhead obstructions. DO NOT attempt to direct exhaust into a different space by attaching ductwork ... will result in poor performance.</b>
8	Grease Tray	Catches & collects grease residue that drips from the blowers. Tray should be checked & emptied daily ... cleaned as needed.
9	EAC Drip Cups (2)	Catches & collects grease residue that may drip down from E.A.C. filter cells. Should be checked & emptied daily ... cleaned as needed.
10*	Drip Cup	Catches & collects grease condensate generated at the baffle filters. Cup should be checked & emptied daily ... cleaned as needed.

\*Hidden

3.03 Accessory Items Included w/ Hood

Part	Description/ Part Number	Function
	<p>Baffle Filter (2) required <b>P/N 42300</b></p>	<p>Captures large grease particle contaminant from the air stream.</p>
	<p>Pre-Filter (2) required <b>P/N 91707</b></p>	<p>Removes additional grease-laden vapor and moisture from the air. Single use only. Must be replaced weekly (approx.)</p>
	<p>E.A.C. Collector Cell <b>P/N 20521 (Left Side)</b> <b>P/N 20520 (Right Side)</b></p>	<p>Captures fine grease particulate and some smoke contaminant from the air. Must be cleaned daily.</p>

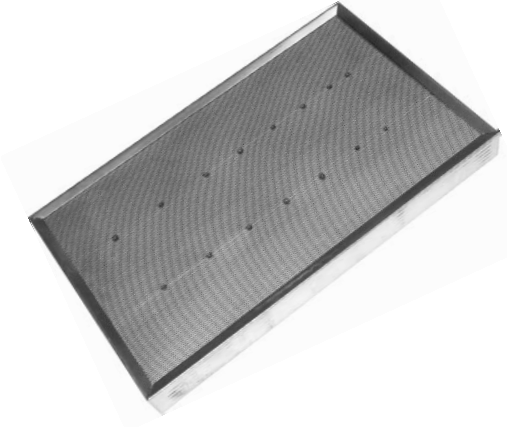
3.03 Accessory Items Included w/ Hood - continued

Part	Description/ Part Number	Function
	<p>Charcoal Filter (2) required <b>P/N 32056</b></p>	<p>Helps control cooking aromas in the exhausted air. Single use only. Must be replaced approximately every 30 - 40 days. <b><u>Will not completely eliminate odor</u></b></p>
	<p><b>(2) Sample Can</b> Foaming Crystal Cleaner/Degreaser <b>P/N 41510</b> <b>12-count Case</b> <b>NSF approved</b></p>	<p><b><u>GILES recommended collector cell cleaner.</u></b></p> <p>Spray foam degreaser for cleaning EAC collector cells. It is readily available from Giles and on-line distributors, as well as other nationwide retail outlets.</p>



## 4. Operation & Filter Maintenance

### 4.01 Starting the Hood

Be sure that all filters are in place & both filter access doors are closed & latched securely before starting the hood.  
***Hood will NOT power-up if either filter door is open, or ajar.***

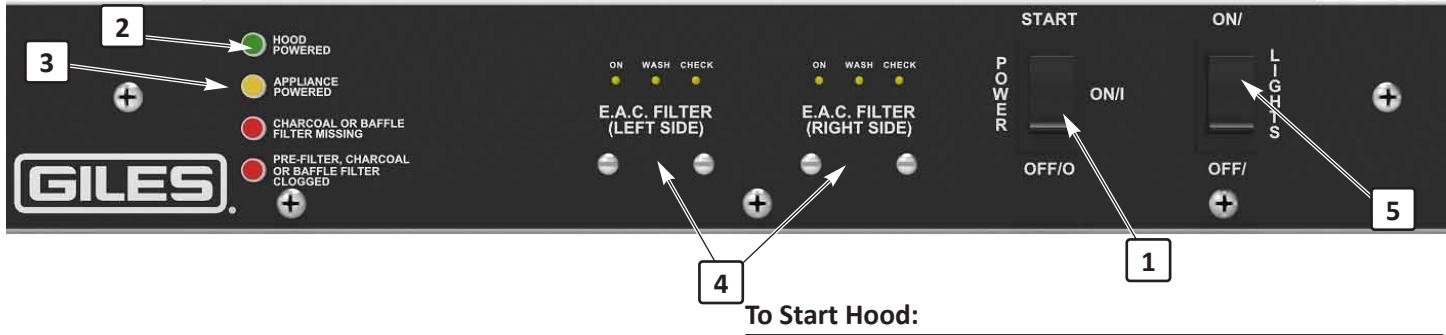

1. Press & momentarily hold the top [START] portion of the **POWER** switch ① until both hood blowers start running. Release & switch will spring back to remain ON. Green **HOOD POWERED** light ② should turn ON.
2. An alarm may sound briefly until the blower reaches full speed, then the amber **APPLIANCE POWERED** light ③ should turn ON. Cooking appliances under the hood should now be receiving power and be ready for use.
3. Both **E.A.C. FILTER [ON]** lights ④ should turn ON.
4. Place **LIGHT** switch ⑤ in [ON] position to turn on under-hood lighting.

#### To Shutdown Hood:

1. Press the bottom [OFF] portion of the **POWER** switch ①.
2. Blowers stop running & all indicator lights turn OFF.
3. Power to the cooking appliances is shutdown.

## 4.02 Filter System, Filter Maintenance & Filter Alarms

### 4.02.1 Ventless Hood Filter Table

Filter	When to Clean/ Replace	How to Remove	How to Clean	How to Install
Baffle Filter	Clean daily	Section 4.02.2	Section 4.04.1	Section 4.02.3
Pre-Filter	Replace every 7 to 10 days	Section 4.02.4	<b><i>DO NOT attempt to clean. replace ONLY!</i></b> Section 4.04.3	Section 4.02.5
E.A.C. Collector Cell	Clean daily	Section 4.02.6	Section 4.04.2	Section 4.02.7
Charcoal Filter	Replace every 30 to 40 days (approx.)	Section 4.02.8	<b><i>DO NOT attempt to clean. replace ONLY!</i></b> Section 4.04.4	Section 4.02.9

## 4.02.2 Baffle Filter Removal



① Turn hood power OFF

Baffle filters are located underneath the hood, directly above cooking appliances.

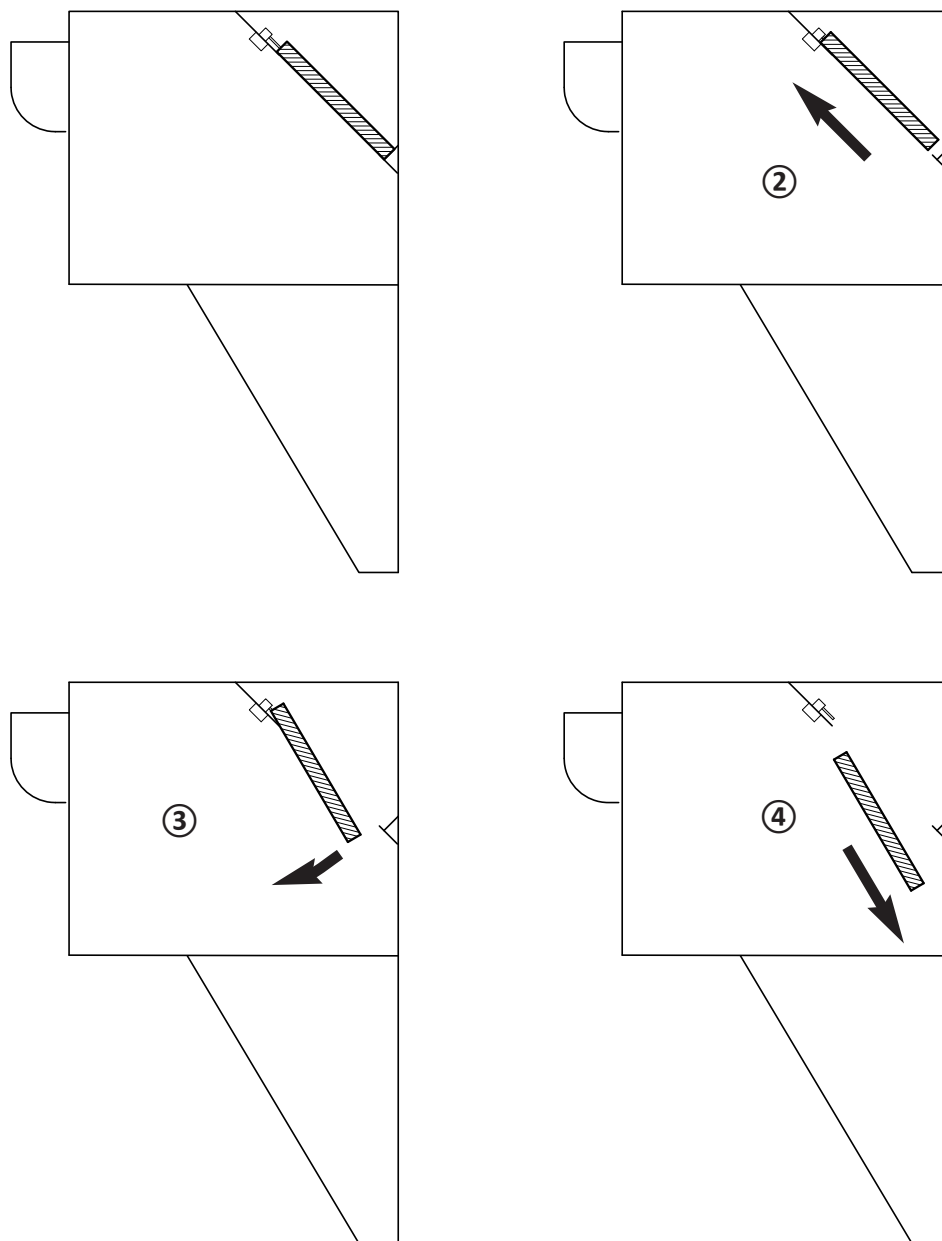

4.02.3 Baffle Filter Installation

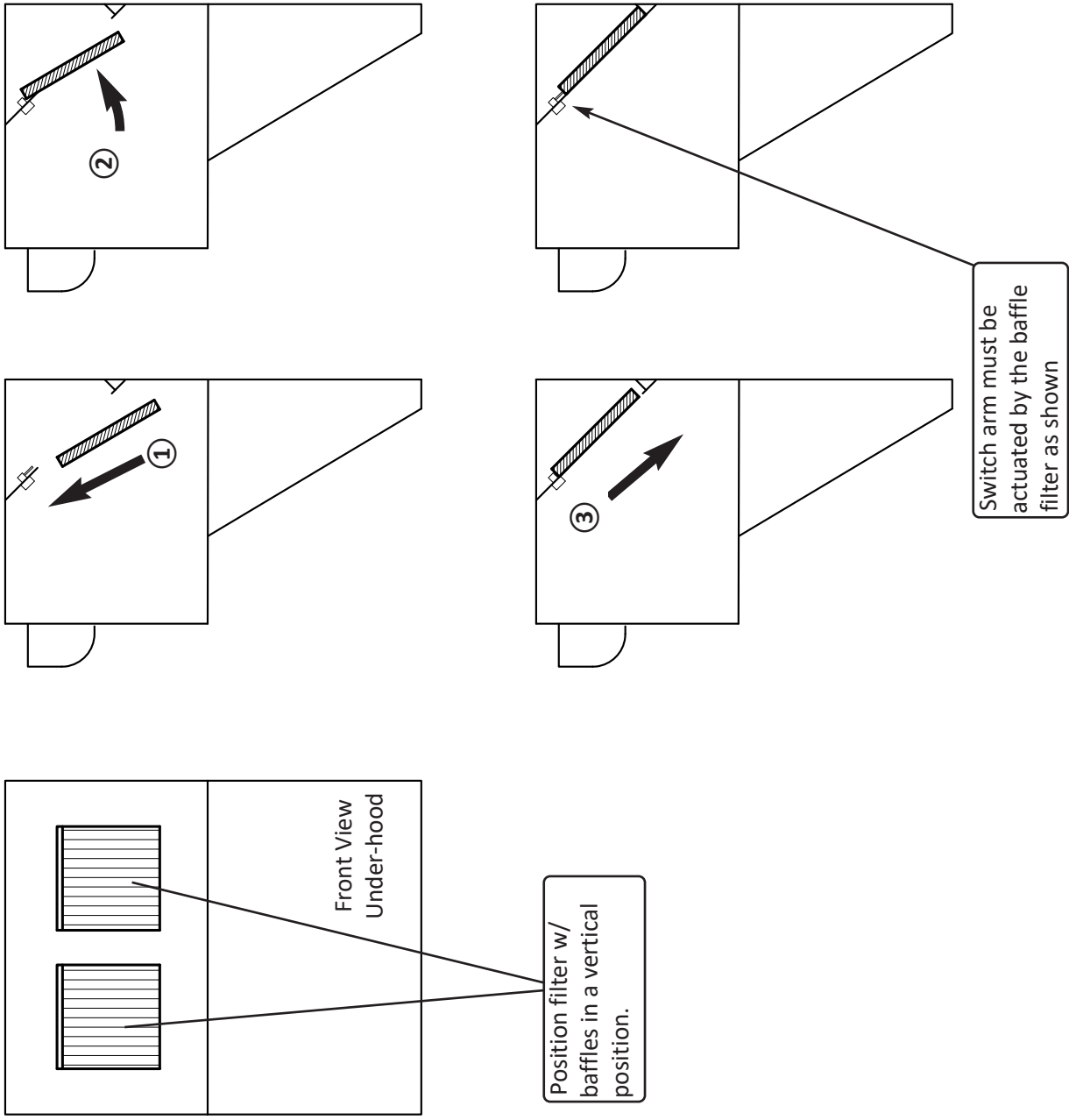

## 4.02.4 Pre-Filter Removal



① Turn hood power OFF

Pre-filters are located inside the filter chamber in the outermost position on each side.

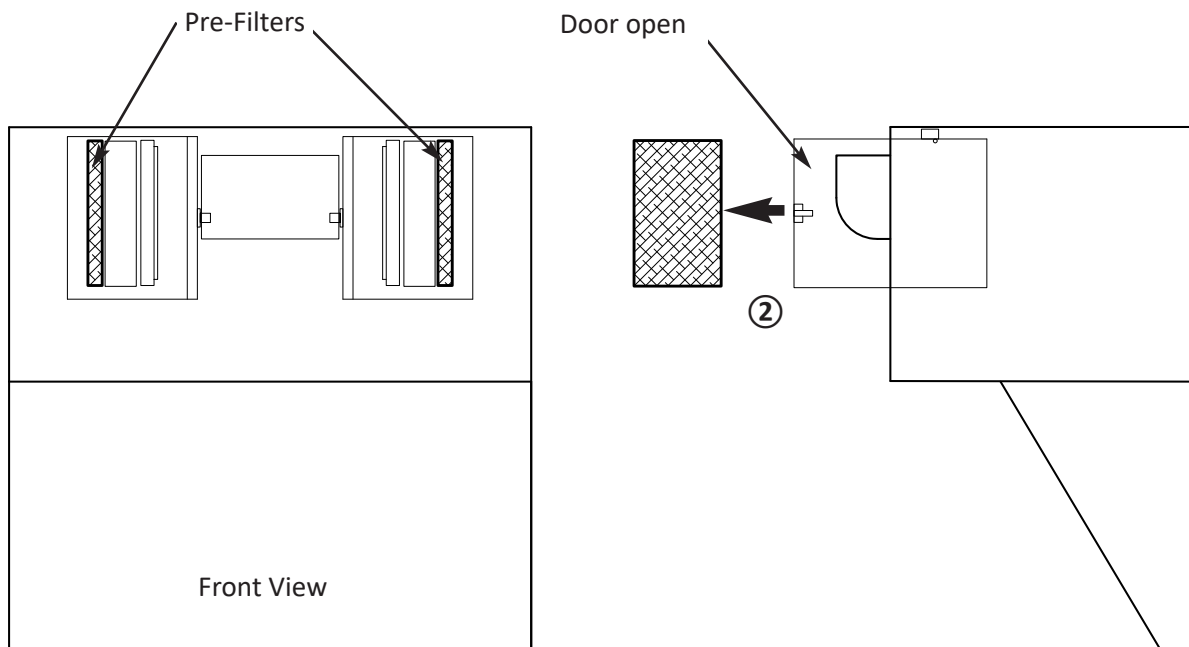

## 4.02.5 Pre-Filter Installation

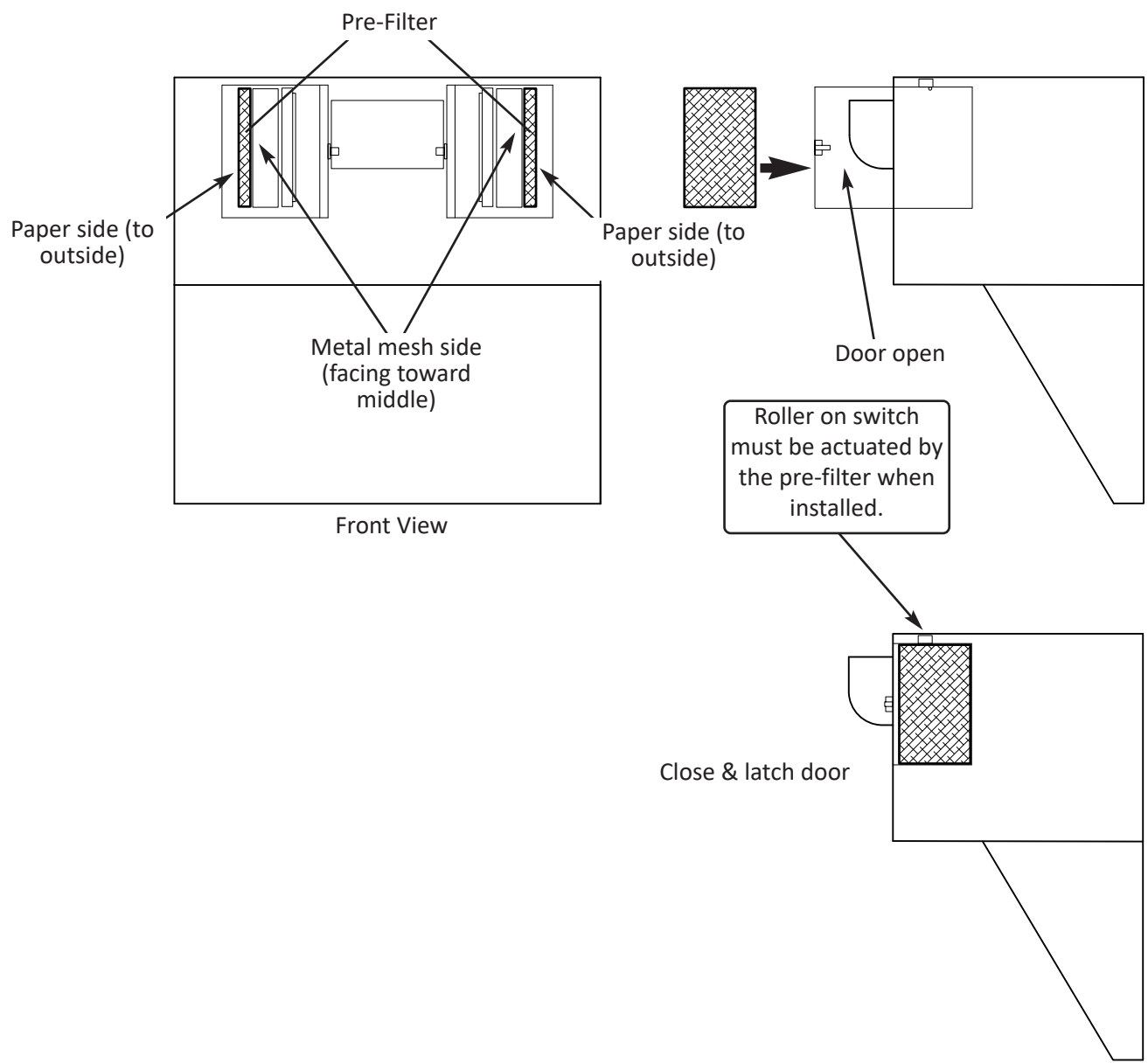

**NOTE:**  
When filters are changed, always record the installation date in the space provided on the filter label.

## 4.02.6 E.A.C. Collector Cell Removal



① Turn hood power OFF

Collector cells are located inside the filter chamber in the middle position on each side.

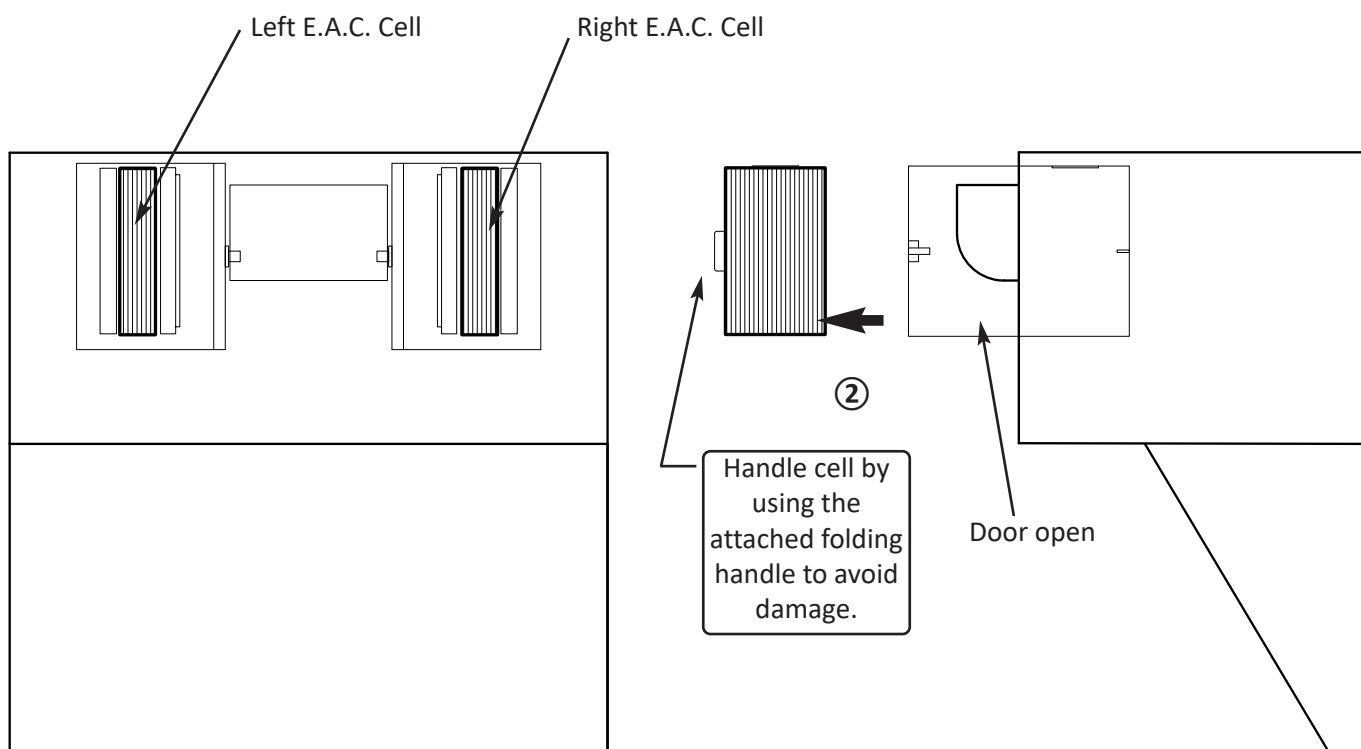

## 4.02.7 E.A.C. Collector Cell Installation

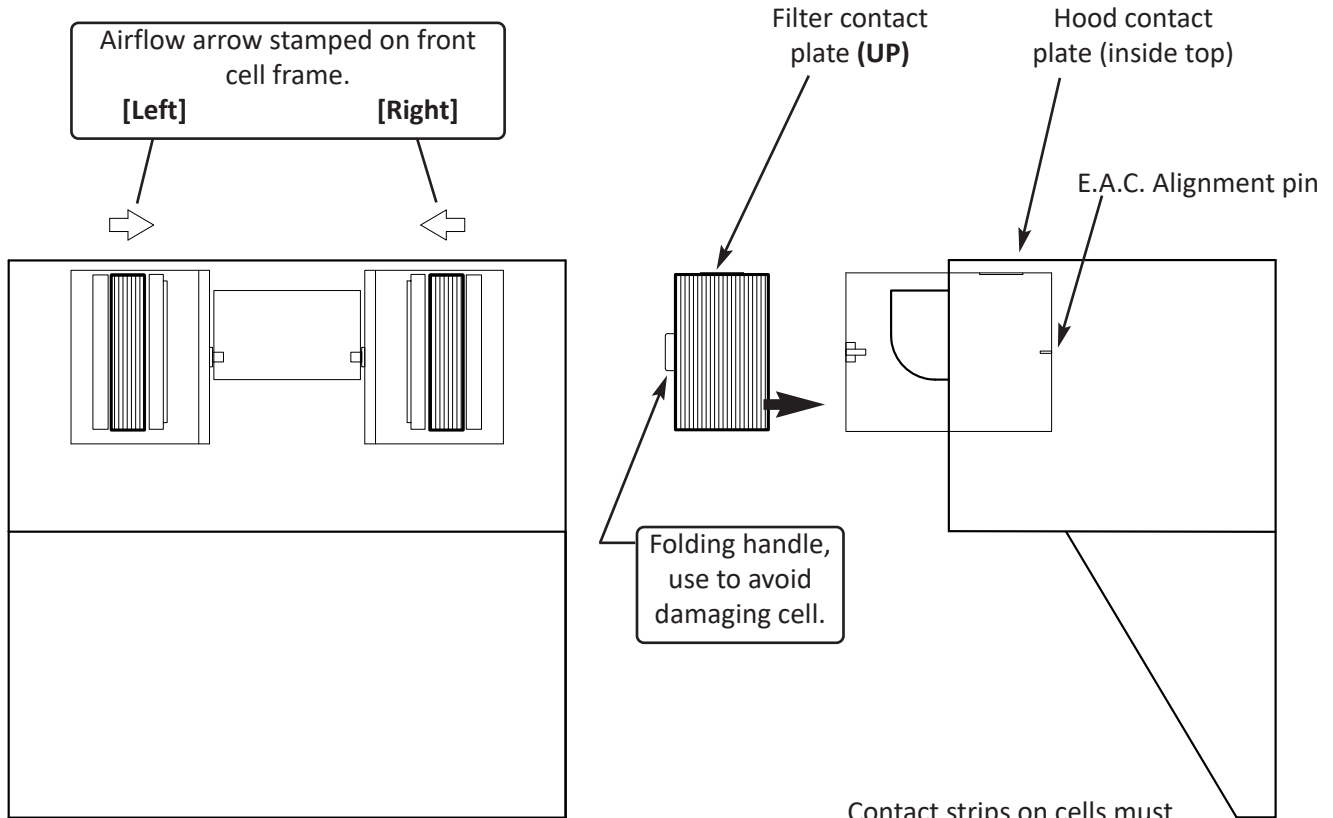

Contact strips on cells must make good connection with contact plates inside hood.

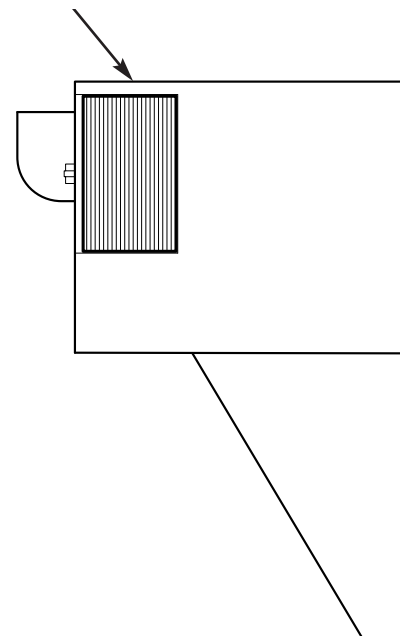

**IMPORTANT!**  
*E.A.C. collector cells are side-specific. Always take care when installing to avoid improper positioning. Contact plates of both cells must be positioned toward top of hood when inserted, and airflow arrows must point toward the hood center.*  
*If cell does not engage the alignment pin and slide fully into the hood, it is NOT positioned properly.*

## 4.02.8 Charcoal Filter Removal



① Turn hood power OFF

Charcoal filters are located inside the filter chamber in the innermost position on each side.

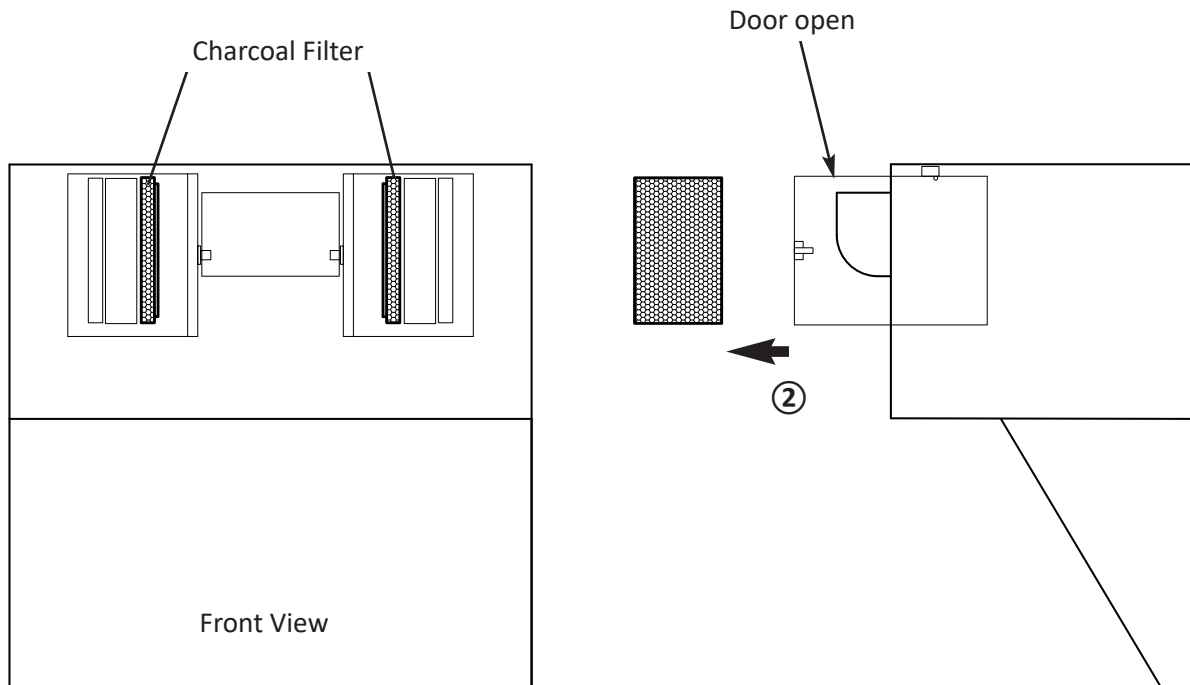

## 4.02.9 Charcoal Filter Installation

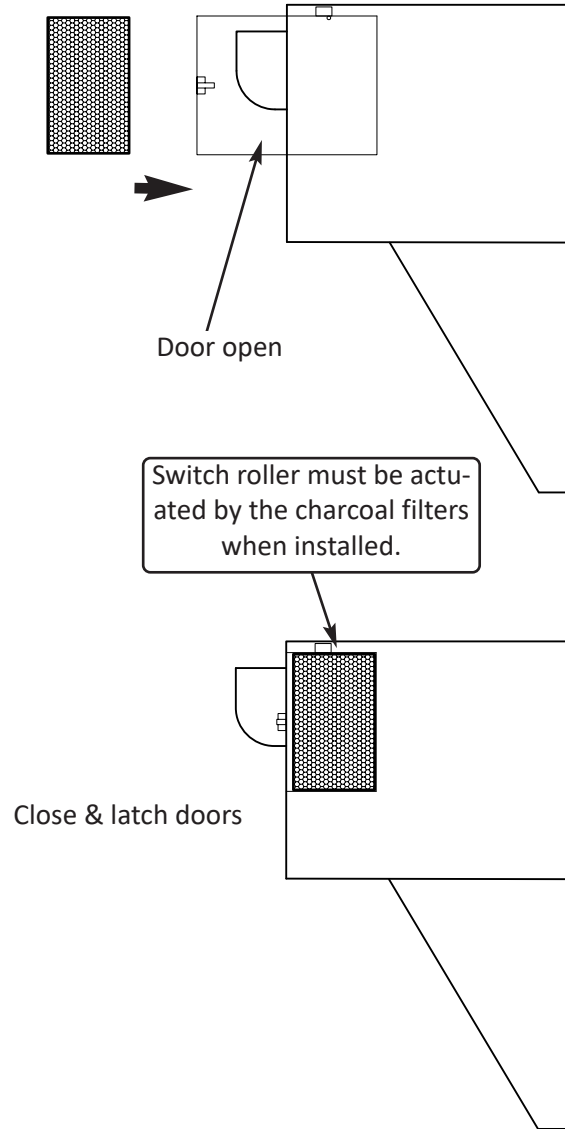
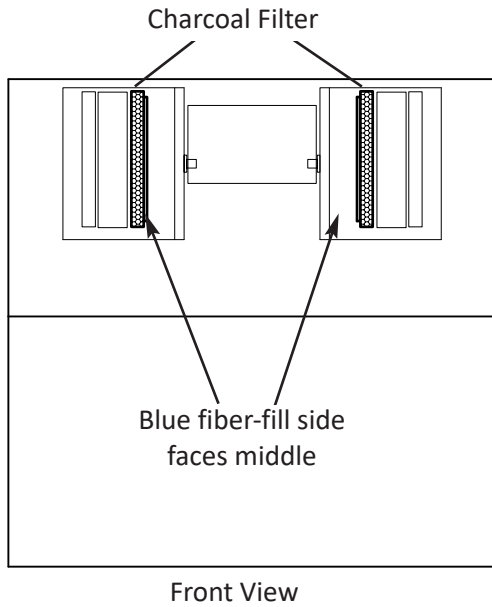

## 4.03 Hood Filter Alarms

### 4.03.1 Baffle, Pre-Filter or Charcoal Filter Missing

If either *baffle filter*, *pre-filter*, or *charcoal filter* is not in place, or positioned incorrectly, the red **[CHARCOAL OR BAFFLE FILTER MISSING]** light will turn ON. Power to cooking appliances under hood is shutdown until the condition is corrected ... the amber **[APPLIANCE POWERED]** light turns OFF. No audible alarm will sound.

- Hood blowers continues to run ... turn OFF hood power.
- Confirm that all filters are in place.  
See [Sections 4.02.3 • 4.02.5 • 4.02.9, Filter Installation.](#)
- Remove & reinstall the filters to ensure that they are seated properly in guides, pushed fully into the filter compartment & that doors close properly. Each filter must also actuate a proofing switch located in the filter channels (charcoal & pre-filter switches are in the top of the compartment; baffle filter switches are located in the filter rack under hood).
- Restart hood ... if condition persists, call for service.



### 4.03.2 Baffle, Pre-Filter or Charcoal Filter Clogged

If *baffle filters*, *pre-filters*, or *charcoal filters* become clogged, or other conditions exist that obstruct airflow through the hood such that it falls below the minimum required for effective capture of cooking vapors, the **[PRE-FILTER, CHARCOAL OR BAFFLE FILTER CLOGGED]** light will turn ON. Power to all cooking appliances under hood is shutdown until the condition is corrected ... the amber **[APPLIANCE POWERED]** light turns OFF. A steady (constant) tone audible alarm will begin sounding.

- Hood blowers continue to run ... turn OFF hood power.
- Clean the baffle filter ([Section 4.04.1, Baffle Filter Cleaning](#)).
- Replace pre-filters or charcoal filters with fresh new filters ([Section 4.04.3, Pre-Filter Maintenance](#) • [Section 4.04.4, Charcoal Filter Maintenance](#))
- Inspect inside the hood plenum to ensure that no other obstructions are present.
- Check the hood exhaust outlet & be sure that nothing is obstructing it or the surrounding area.
- Restart hood ... if condition persists, call for service.



## 4.03.3 E.A.C. Filter Status & Alarm

Two LED indicator light clusters on the control panel show the operational status of the Electronic Air Cleaner (EAC) filter system for each side of the hood.

**[ON]** Indicates that the collector cell is installed, powered & operating. This will be only light ON when the system is operating properly.

**[WASH]** This light turns ON to indicate:

- Filter cell is not installed or is mis-aligned.
- Collection fins are dirty ... contain excessive amounts of captured grease residue.
- Poor contact between cell & contact plate inside hood.
- Too many ionizer wires are broken or missing.

When **[WASH]** light is ON, an alarm condition exists & air cleaning is not occurring. Approximately two (2) minutes after light turns ON, a beeping alarm will begin to sound & shortly thereafter, power to the cooking appliances under hood is shutdown ... **[APPLIANCE POWERED]** light turns OFF.



**[WASH]** light is **NOT** intended as the signal for routine cleaning of the cell, **DO NOT use it as such**. Typically, the collection cell must be cleaned **DAILY** to ensure optimum performance. See [Section 4.04.2, EAC Filter Cell Cleaning](#).

**[CHECK]** This light turns ON to indicate:

- Ionizer wire broken & shorted out against collector cell frame.
- Cell is damaged & shorted out to ground.
- Collection fins are shorted out due to of excessive moisture.

When **[CHECK]** light is ON, system is no longer operating to clean the air, even though hood continues to run & the cooking appliances continue to receive power. **DO NOT CONTINUE TO OPERATE HOOD WHEN THIS CONDITION EXIST ... DAMAGE TO SYSTEM CAN OCCUR ... DETERMINE CAUSE & CORRECT!**

**NOTE: If none of the LED lights turn ON when hood is started, the EAC power supply may be faulty ... call for service.**

Before calling for service, try the following to clear the alarm condition:

1. Turn OFF hood **POWER** switch.
2. Remove the EAC collector cells, clean & dry as described in [Section 4.04.2](#).
3. Inspect the cell for broken or missing ionizer wires, bent fins, or other damage. Ionizer wires are replaceable (when ordering replacements, specify **20" wires**). Bent fins may be gently straightened by hand, such that no fins are touching adjacent fins. If collector cell has excessive damage (*broken/badly bent frame, broken insulators, etc.*), it must be replaced.
4. Inspect the EAC contact plates inside hood compartment. Clean any grease accumulation from contacts with a mild degreasing cleaner & dry thoroughly.
5. Replace collector cells ([Section 4.02.7](#)) in hood & restart ([Section 4.01](#)). If the condition persist, contact a factory-authorized equipment service company.

## 4.04 Filter Maintenance

The following sections describe procedures necessary for cleaning & maintaining filters in the **FSH-4 Ventless Hood**. **Conscientious adherence to these procedures is essential for maintaining optimum & satisfactory hood performance.**

### 4.04.1 Baffle Filter Cleaning



The stainless steel baffle filter is fabricated from thin gauge sheet metal that can potentially have sharp edges. Exercise due care when handling and cleaning to avoid injury.

*It is recommended to wear heavy-duty rubber gloves.*

Ideally, grease baffle filters should be cleaned daily. Remove & clean in sink with a mild, biodegradable, degreasing cleaner (*Giles recommends Simple Green® Crystal Foaming Spray Cleaner*). Rinse & dry thoroughly ... reinstall dry filters in hood. Generally, baffle filters can be washed in a dishwasher.

**Ensure that filters are completely dry before reinstalling in hood. NEVER PLACE A WET FILTER INTO THE HOOD!**

### 4.04.2 E.A.C. Collector Cell Cleaning



The E.A.C. collector cell contains parts fabricated from thin gauge sheet metal that can potentially have sharp edges, which may cause cuts if not handled properly. To avoid injury, exercise due care when handling and/or cleaning the cell.

*It is recommended to wear heavy-duty rubber gloves as a precaution.*

The EAC collector cell is sustainable & renewable ... it should last for years if cleaned and handled properly. To maintain peak performance, it **MUST BE CLEANED DAILY** ... failure to do so can lead to an interruption of cooking appliance operations, premature failure of the EAC system, or reduced useful life of consumable charcoal filters. Follow the procedures detailed below for effective cleaning.

**IMPORTANT: The cell CANNOT withstand washing in commercial dishwashing equipment, and some commercial cleaners/detergents will cause oxidation, or create a layer of contamination on the aluminum collection fins that can lead to system malfunction and result in interruption of power to cooking appliances under the hood.**

Two (2) different cleaning methods are endorsed by GILES Food Service, as follows.

- **Preferred: Spray Method** ... uses *Simple Green® Crystal Foaming Spray Cleaner/Degreaser*. A readily available foaming aerosol that is an exceptionally effective cleaner, and safe for use on aluminum (*NSF approved, food-grade, non-toxic & biodegradable*). Cleaning the collector cell is quick & easy with this convenient ready-to-use cleaner. A complimentary sample is supplied with new equipment. It can be ordered from Giles, **item #41510 (12-count case)**. When used as directed, a case of cleaner should provide approximately a 4 to 5 week supply, depending on equipment usage
- **Alternative: Soak Method** uses a diluted solution of *Simple Green® Pro-HD* & water. Although not as convenient as the spray method, requiring more planning & time, this procedure has proven to be very satisfactory for cleaning EAC collector cells for many years. This product has the same characteristics of the spray product, but requires mixing with water before use in the **dilution factor of 1:12**, e.g. 1/2 gal. of cleaner to 6 gals. of water.



**With proper care, cleaning, and handling, the EAC collector cell is designed to provide years of service.**

## 4.04.2 E.A.C. Collector Cell Cleaning - continued

### CAUTION

While handling & cleaning the cell, take care not to bend the collection fins or break the fine ionizer wires stretched across the face of the cell. Bent fins and broken & missing wires can prevent the electronic collection system from performing properly. System faults & alarms will occur that can potentially interrupt appliance operations or cause damage to the system.

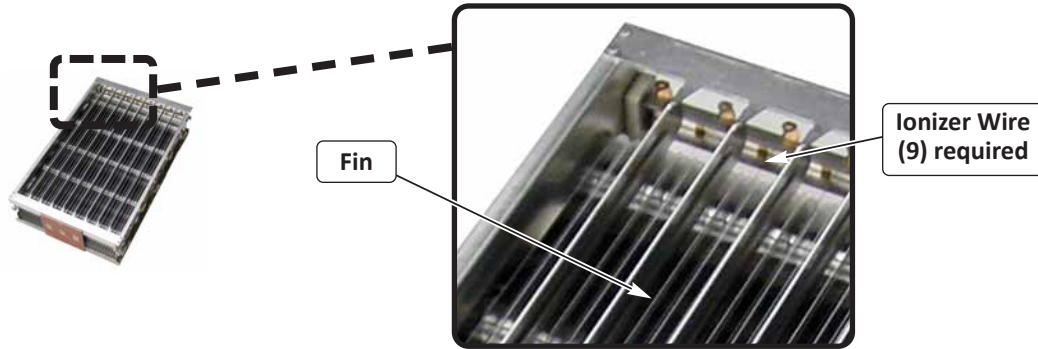

*Damage from abusive handling and/or improper maintenance may not be covered by the factory warranty.*

### A. Preferred - Spray Cleaner Method

1. Remove collector cells from hood (see [Section 4.02.6](#)) and lay on a drain board or other suitable surface.

2. Hold can at an appropriate distance & spray **Simple Green® Crystal Foaming Degreaser** onto the cell, completely covering all surfaces ... collection fins, contact plate, brass fittings & inside corners of the frame. Turn cell over & apply to the other side in like manner, ensuring that both sides of all collector fins are completely covered with foam.

3. Allow foam to soak for **5 to 10 minutes**. In cases of extreme build-up, a second application may be required after rinsing.

4. Carefully move cell to sink & rinse thoroughly, using hot water spray. **Rinse ONLY, DO NOT scrub with brushes.**

5. Stand cell upright on end on a drain board, w/contact plate up ... allow it to drain & air dry overnight. The cell must be completely dry before being replaced in hood. If desired, a small electric fan can be set up to blow across the cell to help expedite drying.

6. Before replacing cell in hood, inspect for broken & missing ionizer wires and bent fins. Broken or missing wires need to be replaced promptly. Bent fins may be straightened by hand so that no fins are touching adjacent fins.

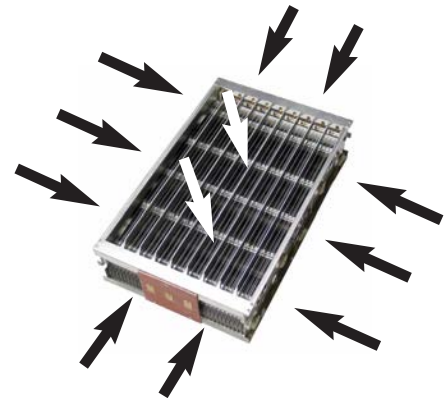

**IMPORTANT! ONLY Simple Green® Crystal Foaming Cleaner/Degreaser is recommended by GILES for cleaning the EAC cell in this manner. Other cleaners can contain corrosive ingredients that may damage the metal components of the cell, causing it to fail or not perform properly. Such damages are not covered by the factory warranty.**

## 4.04.2 E.A.C. Collector Cell Cleaning - continued

### B. Alternate - Soaking Method

The factory-recommended product to use for cleaning the collector cell in this manner is **Simple Green® Pro-HD**. It is a readily available, biodegradable, non-toxic degreasing cleaner that is safe for use on aluminum. It performs well to clean collector cells when diluted with water in a **1:12 ratio** (e.g. 1/2 gal. cleaner to 6 gals clean water).

**DO NOT use DISHWASHING DETERGENTS or CORROSIVE CLEANERS as they can contain ingredients that may damage the metal cell components, causing failure or unsatisfactory performance. Such damages are not covered by the factory warranty.**

1. The soaking method requires a suitable, leakproof container, such as a tall trash bin, recycle bin, plastic tote, or the *GILES soak tank*\*. Container must be large enough to hold the cell along with enough diluted degreasing solution to submerge it completely for soaking.
2. Fill container with fresh water to a level that will basically cover the cell. Measure the water as container is filled & note the quantity. Add **Simple Green® Pro-HD** in the **ratio of 1:12** to the water (e.g. **8 gals. of water will require 85-1/2 ozs. degreaser**). Stir solution to mix.



\* **NOTE: The GILES soak tank (purchased separately, Item# 91123) is specifically designed & sized for soaking the cell. Add 1/2 gal. of cleaner & fill tank to the marked "FILL" line with clean water.**



3. After preparing a quantity of degreaser solution sufficient to completely cover the cell in the soaking container, hold cell by the contact plate, the frame, or the handle and carefully place it into the solution. Be sure that it is fully submerged.
4. Allow cell to soak for approximately **20 minutes (no more than 30 mins)**, then lift it slightly and briefly agitate up & down in the solution to help dislodge grease residue.
5. Carefully remove cell from container and follow **Steps 4 thru 6** as described in the previous section.



#### NOTE:

Degreasing solution may be used multiple times ... cover container with a lid or other suitable cover when not in use to prevent contamination. Discard & replenish solution when a greasy film remains visible, floating on the liquid.

## 4.04.3 Pre-Filter Maintenance

### CAUTION

Pre-Filters are single-use, disposable filters. NEVER attempt to clean and reuse; doing so can cause damage to the unit.

Typically, pre-filters should be replaced weekly (see [Sections 4.02.4 & 4.02.5](#)). They **CANNOT** be cleaned and are not intended for long-term use.

Use GILES replacement **Item No. 91707**. Write the replacement date on the new filter.

**IMPORTANT: Failure to use Giles OEM parts and OEM replacement filters may void the factory warranty.**

## 4.04.4 Charcoal Filter Maintenance

### CAUTION

Charcoal filters are single-use, disposable filters. NEVER attempt to clean and reuse; doing so can cause damage to the unit.

Charcoal filters are consumable items which must be replaced periodically (see [Sections 4.02.8 & 4.02.9](#)). They **CANNOT** be cleaned and reused. Typical replacement frequency is every **30 to 40 days**, depending on cooking activities & volume.

Use GILES replacement **Item No. 30256**. Write the replacement date on the new filter.

**IMPORTANT: Failure to use Giles OEM parts and OEM replacement filters may void the factory warranty.**

## 5. Hood Cleaning & Maintenance

This section describes the steps for general maintenance & cleaning of the **FSH-6 Hood**. Attention to these procedures will help ensure the hood remains in good operating condition and continues to run efficiently and safely.

A **Maintenance & Service Log** is provided, see **Section 5.04**.

### 5.01 Monthly Hood Interlock Inspection (Can be Performed by User)

The hood design incorporates a series of interlock switches to ensure that the unit will shutdown when conditions exist that are not consistent with safe and effective operation. These interlocks should be tested **MONTHLY** as described below. Use the **Maintenance & Service Log** to record completion of the test. If problems are detected, contact **GILES** or an authorized service provider. **NOTE: Anytime a filter access door is opened and closed, the hood must be restarted with the power switch.**

1. **Door Interlock Test:** Start hood ... with hood running, unlatch and slightly open each access door, one at a time. When each side is opened, confirm that hood powers OFF and cooking appliances under the hood cannot be turned ON.
2. **Baffle Filter Test:** Remove the *baffle filter* from one side ... start hood. Verify that the red **[FILTER MISSING]** light turns ON. Check to ensure that cooking appliances under hood will not turn ON. Replace filter & repeat the test on the other side. See **Sections 4.02.2 & 4.02.3, Removal & Installation**.
3. **Pre-Filter/Charcoal Filter Test:** Same procedure as #2 except perform for each pre-filter and charcoal filter, **one at a time in succession**. Reinstall the filters. See **Sections 4.02.4, 4.02.5, 4.02.8 & 4.02.9, Removal & Installation**.
3. **E.A.C. Filter Test:** Remove one of the EAC collector cells, close & latch door ... start hood. Verify that **[WASH]** light on **EAC Status** comes ON for the side without cell. Wait approx. two (2) minutes. A beeping alarm should begin sounding ... after a few seconds, check to ensure that cooking appliances under hood cannot be turned ON. Turn off hood, reinstall cell, and repeat for other side. See **Section 4.02.6. & 4.02.7, Removal & Installation**.
4. **Filter Clogged Test:** **Perform this test ONLY after installing new prefilters & charcoal filters.** Start hood normally and allow to run. Use cardboard, or other suitable material, and completely block the hood exhaust outlet ... hold firmly in place so that no air is escaping. Within a few seconds, a continuous tone alarm should begin sounding. Check to ensure that cooking appliances under hood cannot be turned ON. Remove the obstruction ... the alarm should silence and you should be able to turn ON cooking appliances again.

Should any of the tests fail to yield the described results, contact a factory-authorized service company and have the unit evaluated and repaired. A *Giles Manufacturer's Representative* can provide information about nearby authorized service providers, or call **GILES Services at 800-554-4537** for assistance.

## 5.02 Quarterly Hood Cleaning

### CAUTION

- DO NOT** wash down hood with water from a spray hose.
- DO NOT** steam clean or use pressure washing equipment.
- DO NOT** use products containing chlorine or other caustic chemicals.
- DO NOT** use abrasive products, steel wool or scouring pads.

The factory-recommended product for general cleaning & degreasing of this equipment is **Simple Green® Crystal Foaming Spray Degreaser/Cleaner**, a readily available, biodegradable, non-toxic degreasing cleaner.

To maintain effectiveness & performance, the hood should be deep cleaned *every 3 months*, at a minimum.

1. Disconnect power from the unit at circuit breaker panel.
2. If possible, unplug & remove cooking appliances from underneath hood.
3. Remove all of the hood filters.
4. Use a soft cloth or sponge, and the mild biodegradable decreasing cleaner (**Simple Green® Crystal Foaming Spray Degreaser/Cleaner is recommended**) to clean surfaces inside the entire hood plenum, removing grease film accumulation.
5. Inspect the hood blowers on each side. If possible, clean grease build-up from the blades using degreaser and a small brush (*use cleaner sparingly*). **NOTE: When restarting hood after cleaning, hold a cardboard box, or other suitable item, over the exhaust outlet to catch cleaning residue which may be discharged from the blowers.**
6. Thoroughly clean the under-hood area & all exterior surfaces with mild degreaser or a good quality stainless steel cleaner.
7. Allow hood to thoroughly dry or wipe dry with clean dry cloth.
8. Clean baffle filters & EAC collector cells see **Sections 4.04.1 & 4.04.2**. If necessary, obtain and install a new fresh pre-filters and charcoal filters. Ensure all filters are properly reinstalled.
9. As necessary, reposition cooking appliances under hood & restore power supply.

## 5.03 Fire Suppression System Maintenance

The fire extinguishing system connected to the hood must be maintained in accordance with the **Standard for Wet Chemical Extinguishing Systems, NFPA 17A** and with the instructions of the system's installer.

All inspections, maintenance, troubleshooting, repairs and general servicing of the fire extinguishing system must be performed by an authorized **Ansul® Distributor/Dealer**. Required maintenance activities are explained in the following sections.

**Consult fire suppression system documentation provided by the system installer for complete maintenance guidelines.**

## 5.03.1 Semi-Annual Fire Suppression System Inspection & Maintenance

Inspection & service of the fire suppression system must be performed by a qualified **Ansul® Distributor/Dealer**. Field inspection of the fire suppression system must be conducted semi-annually (*every 6 months*) and shall consist of the following:

- Confirm that the fire hazard potential has not changed.
- Inspect suppressant storage tank for chemical level and charge pressure.
- Inspect & test the Automan release mechanism.
- Check all nozzles to ensure they are free of grease build-up. Confirm that all nozzle blow-off caps are in place & in good condition ... replace as needed. See **Section 2.06.4, Fire Extinguisher Nozzle Locations**.
- Inspect & test the remote manual activation station for function and wear.
- Install test link in detector & cut to test automatic actuation.
- Inspect & clean detector fusible links. Verify that detector links are of the correct temperature rating. See **Section 2.06.2, Fire Suppression Detector Links & Location**.
- Inspect conduit & wire cable for wear at pulleys & detectors ... replace if necessary.
- Record maintenance date and service performed in a permanent file ... complete sign-off tag & attach to system in a conspicuous location.

## 5.03.2 Annual Fire Suppression System Inspection & Maintenance

Same as **Semi-Annual** maintenance plus the following item:

- All fusible detector links must be replaced with new. See **Section 2.06.2, Fire Suppression Detector Link Specification & Location**.

## 5.03.3 12-Year Fire Suppression System Inspection & Maintenance

Same as **Semi-Annual & Annual** maintenance plus the following items:

- Replace wet-chemical fire suppressant.
- Hydrostatic test & certify suppressant tank & compressed gas charging cartridge. As alternative, components can be replaced with new.
- Flow test the regulator.

# Hood Cleaning & Maintenance

# Ventless Recirculating Hood

FSH-6

## 5.04 Inspection & Maintenance Log

Check								Initial/Date	Check								Initial/Date			
✓	✓	✓	✓	✓				RT 5/15/2021	1	2	3	4	5							
1	2	3	4	5					1	2	3	4	5							
1	2	3	4	5	6				1	2	3	4	5	6						
1	2	3	4	5					1	2	3	4	5							
1	2	3	4	5					1	2	3	4	5							
1	2	3	4	5	6	7			1	2	3	4	5	6	7					
1	2	3	4	5					1	2	3	4	5							
1	2	3	4	5					1	2	3	4	5							
1	2	3	4	5	6				1	2	3	4	5	6						
1	2	3	4	5					1	2	3	4	5							
1	2	3	4	5	6	7			1	2	3	4	5	6	7					
1	2	3	4	5					1	2	3	4	5							
1	2	3	4	5					1	2	3	4	5							
1	2	3	4	5	6				1	2	3	4	5	6						
1	2	3	4	5					1	2	3	4	5							
1	2	3	4	5	6	7			1	2	3	4	5	6	7					
1	2	3	4	5					1	2	3	4	5							
1	2	3	4	5					1	2	3	4	5							
1	2	3	4	5	6				1	2	3	4	5	6						
1	2	3	4	5					1	2	3	4	5							
1	2	3	4	5	6	7			1	2	3	4	5	6	7					
1	2	3	4	5					1	2	3	4	5							
1	2	3	4	5	6				1	2	3	4	5	6						
1	2	3	4	5					1	2	3	4	5							
1	2	3	4	5	6	7			1	2	3	4	5	6	7					
1	2	3	4	5					1	2	3	4	5							
1	2	3	4	5	6				1	2	3	4	5	6						
1	2	3	4	5					1	2	3	4	5							
1	2	3	4	5	6	7			1	2	3	4	5	6	7					

1	Door Check	Section 5.01
2	Baffle Filter Check	Section 5.01
3	EAC Filter Check	Section 5.01
4	Pre-Filter/Charcoal Filter Check	Section 5.01
5	Filter Clogged	Section 5.01
6	Quarterly Cleaning	Section 5.02
7*	Semi-Annual Fire Suppression System	Section 5.03.1
8*	Annual Fire Suppression System	Section 5.03.2

**\* Must be performed by an authorized Ansul® Service Agent**

## 6. Troubleshooting

This section describes basic troubleshooting procedures for **FSH Recirculating Hoods**. Generally, troubleshooting and/or repairs should only be performed by trained & qualified service technicians. Troubleshooting by users should be limited to issues that are operational or procedural in nature.

### **⚠ DANGER**

- Troubleshooting for electrical problems should be performed **ONLY** by trained service technicians or electricians. Serious injury, even death, will result from contact with energized electrical circuits.

### 6.01 Procedures

Problem	Probable Cause	Corrective Action
<b>Hood will not turn ON</b>	a. Filter Access Door not closed	Close & latch Access Door.
	b. Improper start-up method	Press & momentarily hold in top <b>[START]</b> portion of power switch.
	c. Power Switch is faulty	Replace Power Switch.
	c. Improper supply voltage	Connect to proper electrical supply.
	e. Not properly connected to power source.	Confirm connections & correct.
	f. Blown fuse or tripped circuit breaker.	Check fuse in hood and main breaker box.
<b>[FILTER MISSING] light ON at start-up</b>	a. Baffle or Charcoal Filter is not installed or not properly seated	Install appropriate Filter and/or check alignment in track.
<b>EAC [WASH] light ON &amp; beeping alarm sounding</b>	a. Excessive film build-up on fins	Clean the EAC cell, <b>Section 4.04.2</b>
	b. EAC cell is not installed	Install EAC Cell
	c. Poor connection at contact plate inside hood.	Check cell position, clean contacts.
	d. Faulty EAC contact plate	Have plate inspected, replace if needed.
	e. Missing ionizer wires	Replace wires, (9) required.
<b>EAC [CHECK] light ON</b> • <b>[HOOD POWERED] light ON</b> • <b>No alarm sounding</b>	a. EAC shorted to ground (damaged)	Replace or repair the EAC cell.
	b. High voltage wires shorted to ground.	Correct shorted condition.
	c. Collector fins shorted out due to excessive moisture.	Eliminate condensation causes - cold air being drawn into hood, etc.

## 6.01 Procedures - continued

Problem	Probable Cause	Corrective Action
<b>Under-hood Cooking Appliance will not power-up:</b> <ul style="list-style-type: none"> <li>• [HOOD POWERED] light ON</li> <li>• [FILTER MISSING] light ON</li> <li>• [APPLIANCE POWERED] light OFF</li> </ul>	a. Baffle Filter missing or not properly installed	Install Filter / check alignment.
	b. Charcoal Filter or pre-filter is missing or not properly installed	Install Filter / check alignment.
	c. Filter switches are faulty	Test & replace as needed.
<b>Under-hood Cooking Appliance will not power-up:</b> <ul style="list-style-type: none"> <li>• [HOOD POWERED] light ON</li> <li>• [CLOGGED FILTER] light ON</li> <li>• [APPLIANCE POWERED] light OFF</li> <li>• Continuous (steady) tone alarm sounding.</li> </ul>	a. Baffle, Pre-filter, or Charcoal Filter clogged	Replace Charcoal Filter or Pre-Filter; Clean Baffle Filter.
	b. Hood exhaust outlet excessively block	Confirm exhaust is clear of any obstruction around diverter.
	c. Vacuum Switch is out of adjustment	Test & adjust vacuum switch.
	d. Kinked or blocked vacuum line	Remove vacuum line kinks or blockage.
	e. Fan running slow or blades are loaded with grease film	Check voltage and inspect blowers, clean if needed
<b>Under-hood Cooking Appliance will not power-up:</b> <ul style="list-style-type: none"> <li>• [HOOD POWERED] light ON</li> <li>• [WASH] light ON</li> <li>• [APPLIANCE POWERED] light OFF</li> <li>• Beeping tone alarm sounding.</li> </ul>	a. Excessive grease film built up on collector fins; too dirty	Clean the EAC cell, <b>Section 4.04.2.</b>
	b. EAC cell is not installed	Install clean EAC cell.
	c. EAC driver board is faulty	Test & replace EAC power supply if needed.
	d. Poor connection at contact plate, dirty contacts, cell mis-aligned, faulty contacts.	Check cell position, clean contacts, inspect contact plate & replace if needed.
	e. Ionizer wire(s) missing.	Replace missing wire(s).
<b>Under-hood Cooking Appliance operating:</b> <ul style="list-style-type: none"> <li>• [HOOD POWERED] light ON</li> <li>• EAC [CHECK] light ON</li> <li>• [APPLIANCE POWERED] light ON</li> <li>• No alarm sounding, but cell is <b>NOT</b> cleaning air.</li> </ul>	a. Ionizer wire broken & touching chassis.	Replace ionizer wire.
	b. Collector fins shorted to ground by moisture.	Dry cell, determine cause of moisture, cool air being drawn into hood creating condensation.
<b>Under-hood lighting does not come ON.</b>	a. Bulb burned out	Replace bulb.
	b. Faulty light switch	Check and replace switch.



## 7. Parts List

This section lists some of the various parts that are available for replacement on the unit. This is not an all inclusive listing; please contact an authorized *GILES* representative or service company concerning other parts that may be replaced in the field.

### 7.01 Parts Ordering & Service Information

*Giles* is an equipment manufacturer and does not sell parts direct. Parts for our equipment are available through authorized service companies, part distributors, and/or kitchen equipment dealers. If assistance with sourcing parts or equipment repair service is required, please contact a *GILES* Manufacturer’s Representative to assist with locating a parts source or authorized service provider near you. For further assistance you may contact the ***GILES Technical/ Customer Service Support*** as follows:

**IN THE UNITED STATES & CANADA call: 800.554.4537**

**ALL OTHERS call: 334.272.1457**

Normal business hours are 8:00 AM to 5:00 PM Central Time ... calls are handled by an auto-attendant answering system. Please follow the recorded instructions to route your call appropriately. If necessary after hours, leave a voicemail message and a representative should respond within 30 minutes.

Website: [www.gfse.com](http://www.gfse.com) Email: [services@gfse.com](mailto:services@gfse.com)

Our goal at Giles is to provide the highest possible quality of service and assistance. To help us accomplish this, please have the following information readily available when calling, along with a brief description of the problem being experienced. Please record the unit information in the table below for quick reference.

<b>Model:</b>	
<b>Serial Number:</b>	
<b>Voltage:</b>	
<b>Phase:</b>	



The information can be found on a serial/data label similar to this, located on the hood.

7.02 Component Drawer & Control Panel

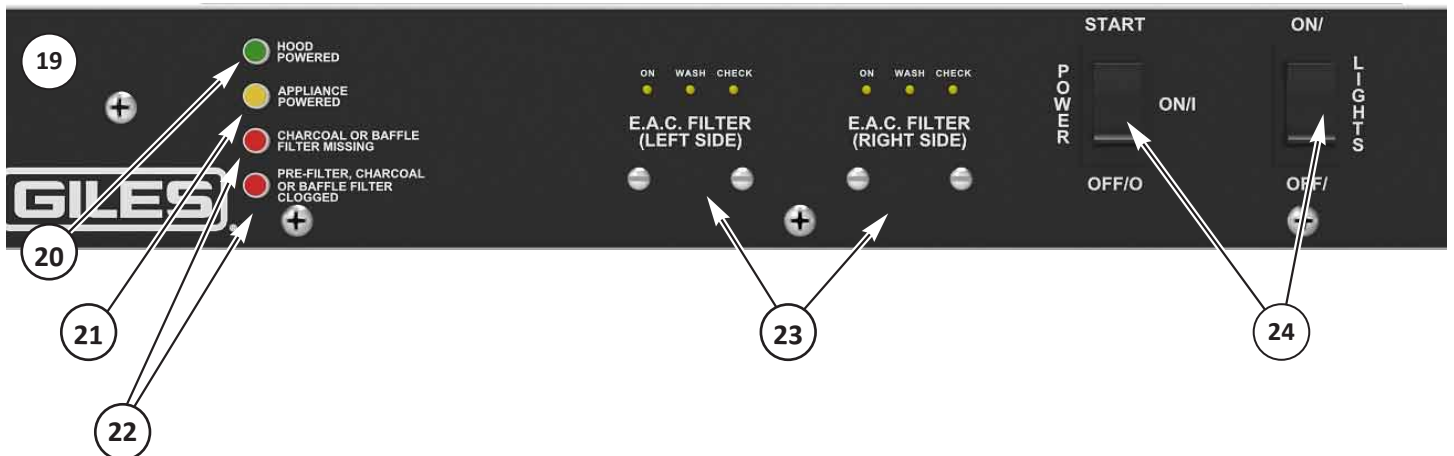
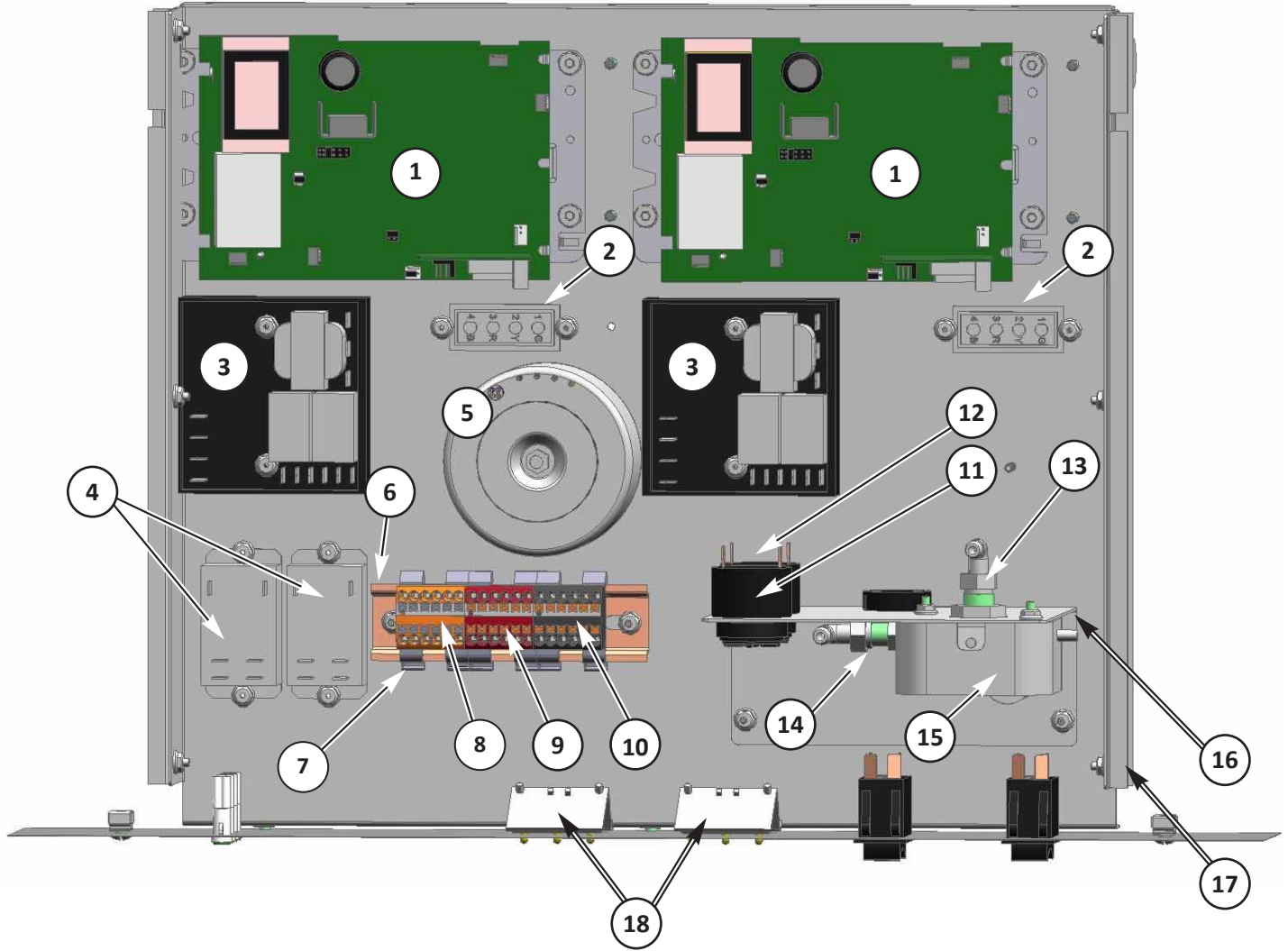

## 7.02 Component Drawer &amp; Control Panel - continued

Item	Part No.	Qty.	Description
1	<a href="#">21296</a>	2	EAC POWER SUPPLY, w/ DRIVER BOARD, 120V
2	-	2	TERMINAL BLOCK (COMES W/ ITEM 1, <a href="#">21296</a> )
3	<a href="#">23776</a>	2	ALARM & SHUTDOWN MODULE, AIR FILTER
4	<a href="#">21417</a>	2	RELAY, POWER SWITCH, 30A/2.5HP, 240V
5	<a href="#">21337</a>	1	TRANSFORMER, 230VAC >115VAC (COMES W/ MOUNTING HARDWARE)
6	91717	1	DIN RAIL, 7"
7	21496	6	CLIP, DIN RAIL, END BRACKET, PTFIX, NS-35
8	21512	1	DIST.BLOCK, 12-PL, 12-26 AWG, ORANGE
9	21509	1	DIST.BLOCK, 12-PL, 12-26 AWG, RED
10	21510	1	DIST.BLOCK, 12-PL, 12-26 AWG, BLACK
11	<a href="#">23782</a>	1	SONALERT, 250V, CONTINUOUS TONE ( <b>TOP</b> )
12	21659	1	SONALERT, 120V, INTERMITTENT BEEP TONE ( <b>BOTTOM</b> )
13	<a href="#">40880</a>	1	FITTING, 1/4 BARBED, 90-EL, NYL, 1/4 NPT
14	<a href="#">40877</a>	1	FITTING, 1/4 BARBED, 90-EL, NYL, 1/8 NPT
15	<a href="#">20390</a>	1	VACUUM SWITCH, ADJUSTABLE
16	80839	1	BRACKET, VACUUM SWITCH
17	41049	2	DRAWER SLIDES, 14"
18	30833	2	BRACKET, EAC LED
19	67320	1	LABEL, CONTROL PANEL
20	<a href="#">21678</a>	1	INDICATOR LIGHT, GREEN, 125-250V
21	<a href="#">21674</a>	1	INDICATOR LIGHT, AMBER, 125-250V
22	<a href="#">21673</a>	2	INDICATOR LIGHT, RED, 125-250V
23	<a href="#">24209</a>	2	LED, EAC STATUS INDICATOR
24	<a href="#">21441</a>	2	SWITCH, ROCKER, (ON)-ON-OFF, 250V, 20A

7.03 Hood Filter Chamber

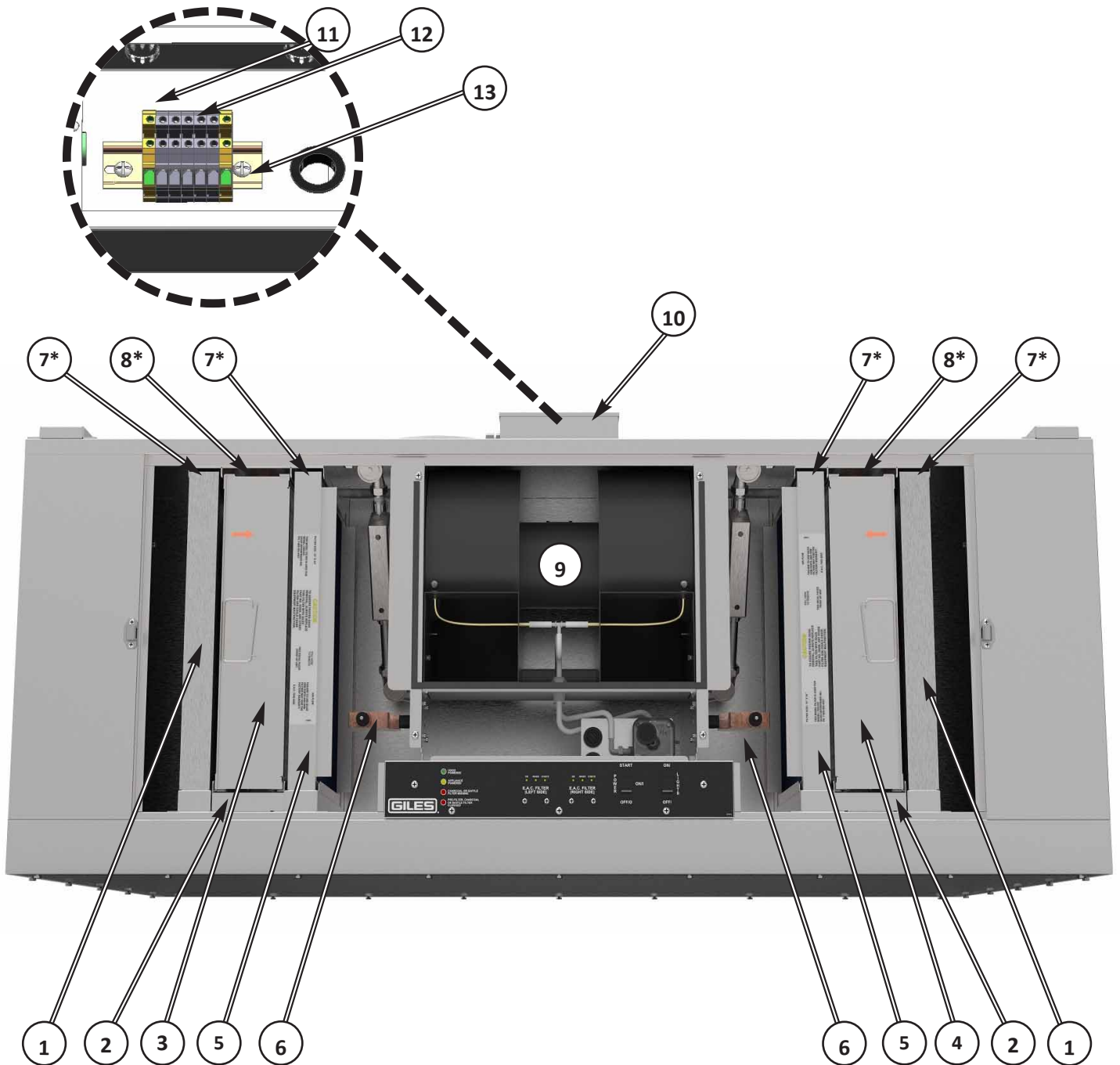

## 7.03 Hood Filter Chamber - continued

Item	Part No.	Qty.	Description
1	91707	2	PRE-FILTER, ASSY, 12 X 20 X 2
2	98146	2	DRIP TRAY, EAC FILTER
3	20521	1	FILTER, EAC 12 X 20, LEFT SIDE ONLY
4	20520	1	FILTER, EAC 12 X 20, RIGHT SIDE ONLY
5	30256	2	CHARCOAL FILTER, ASSY
6	21157	2	SWITCH, PLUNGER, 250V, 15A
7*	23200	4	SWITCH, SNAP ACTION ROLLER
8*	21125	2	CONTACT BOARD, EAC
9	34616	2	BLOWER ASSEMBLY
10	91522	1	BOX, POWER CONNECTION
11	20320	2	TERMINAL BLOCK, 24-8 AWG, GROUND
12	20319	5	TERMINAL BLOCK, DIN, 24-8 AWG, 50A
13	90550	1	RAIL, DIN, TERMINAL BLOCK, 4.0"

\*Hidden

7.04 Under Hood Components

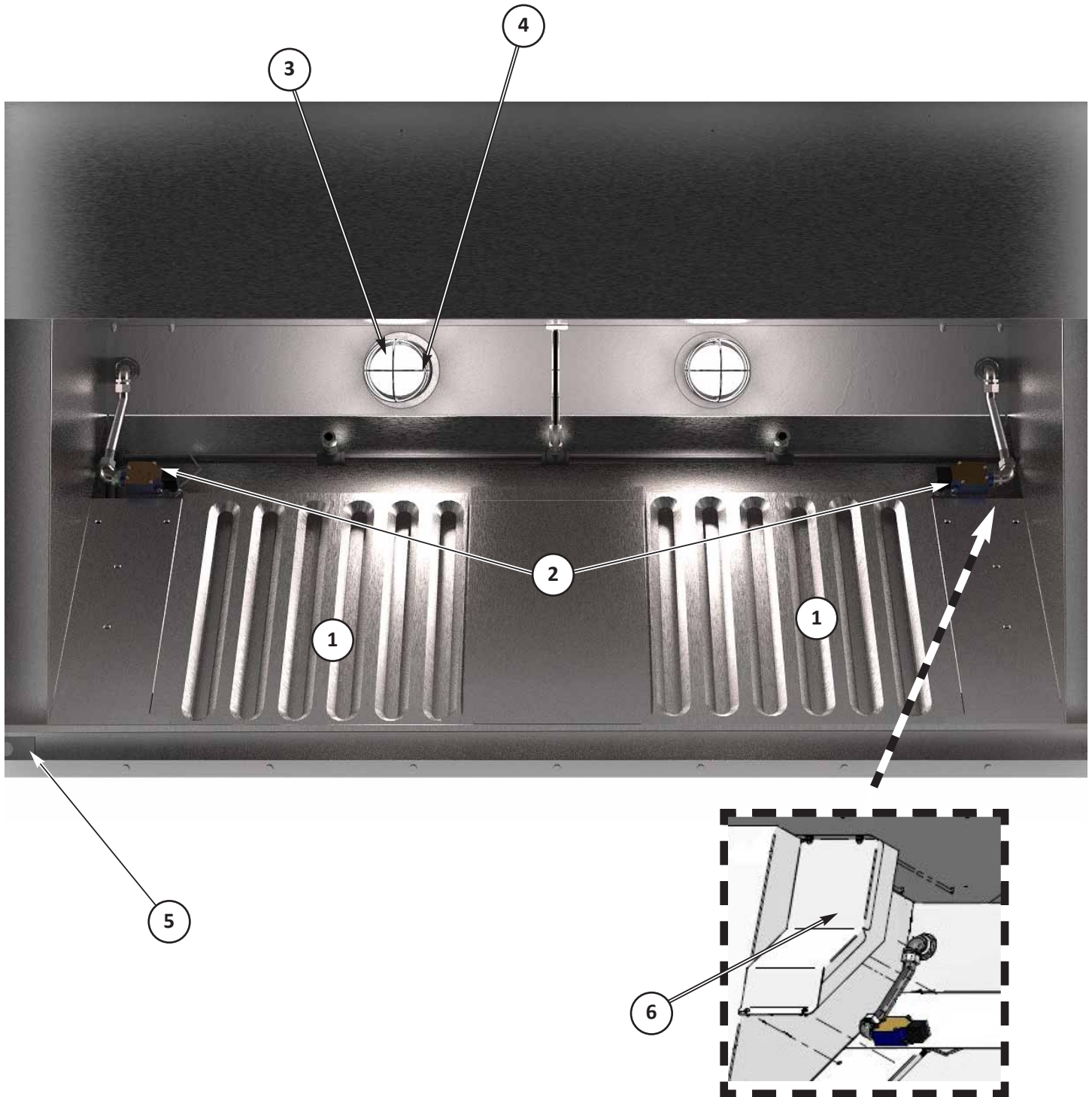

7.04 Under Hood Components - continued

Item	Part No.	Qty.	Description
1	42300	2	BAFFLE FILTER, S/S, 16 X 20
2	32102	2	BAFFLE FILTER SWITCH ASSY.
3	40625	2	LIGHT FIXTURE
4	20395	2	FLUORESCENT BULB, COATED
5	32776	1	DRIP CUP
6	98104	2	CONDUIT COVER

7.05 Hood Front & Floor Stand

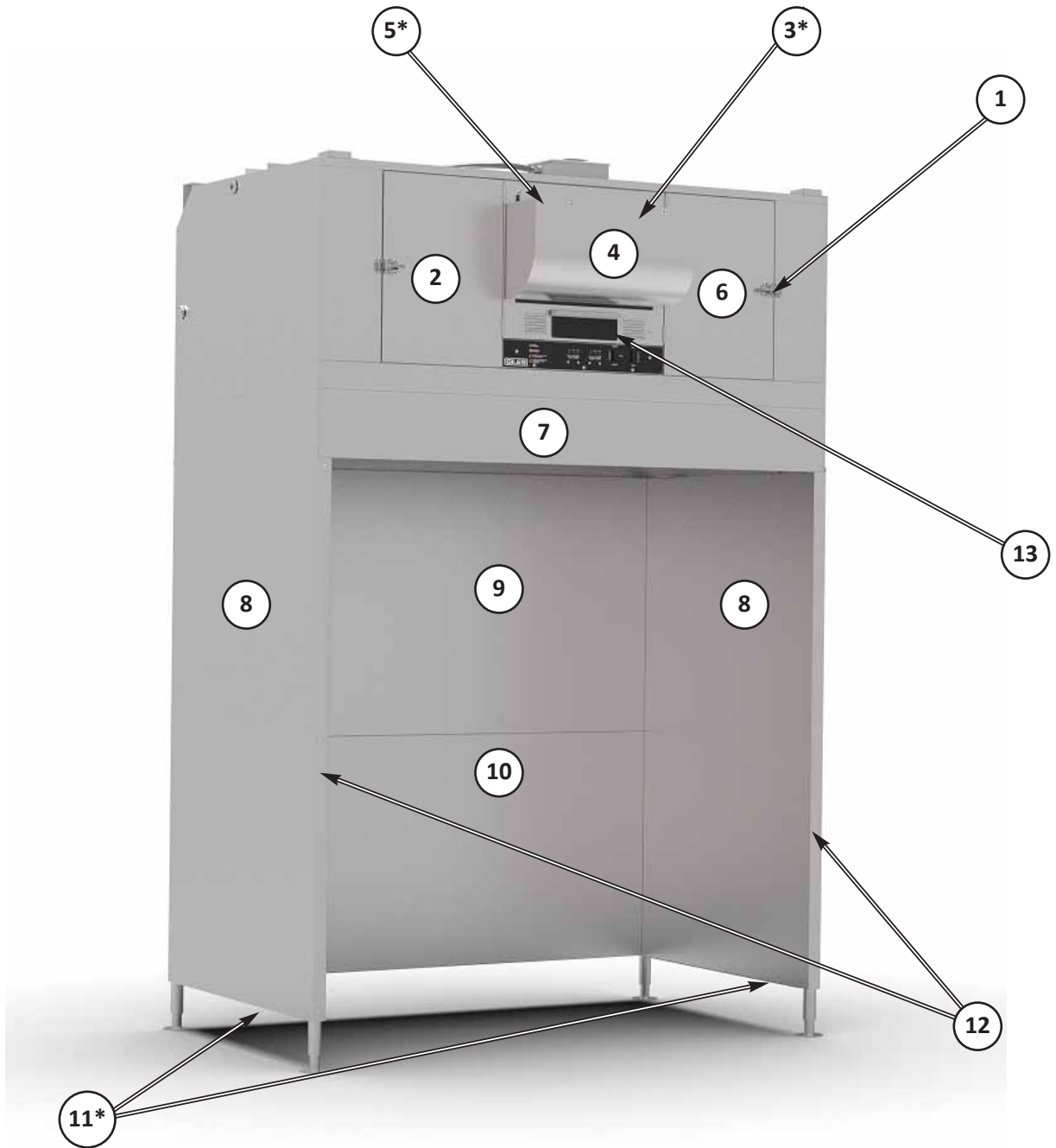

NOTE: Legs are welded in place ... not replaceable.

## 7.05 Hood Front &amp; Floor Stand - continued

Item	Part No.	Qty	Description
1	42827	2	DOOR LATCH
2	98036	1	ACCESS DOOR ASSY, LEFT
3*	46126	1	FIRE DAMPER
4	98141	1	FAN COVER & EXHAUST DUCT
5*	98140	1	GUARD, FIRE DAMPER
6	98037	1	ACCESS DOOR ASSY, RIGHT
7	91945	1	SKIRT, 8IN, STAND MOUNT, ASSY
8	91583	2	72" HOOD STAND SIDE
9	91938	1	72" HOOD STAND, TOP BACK PANEL
10	91940	1	72" HOOD STAND, BOTTOM BACK PANEL
11*	92063	2	CHANNEL, APPLIANCE POSITIONING
12	91708	2	CHANNEL, FRONT TRIM, HOOD STAND-72
13	80870	1	GREASE TRAY ASSY

**NOTE: Legs are welded in place ... not replaceable.**

\*Hidden



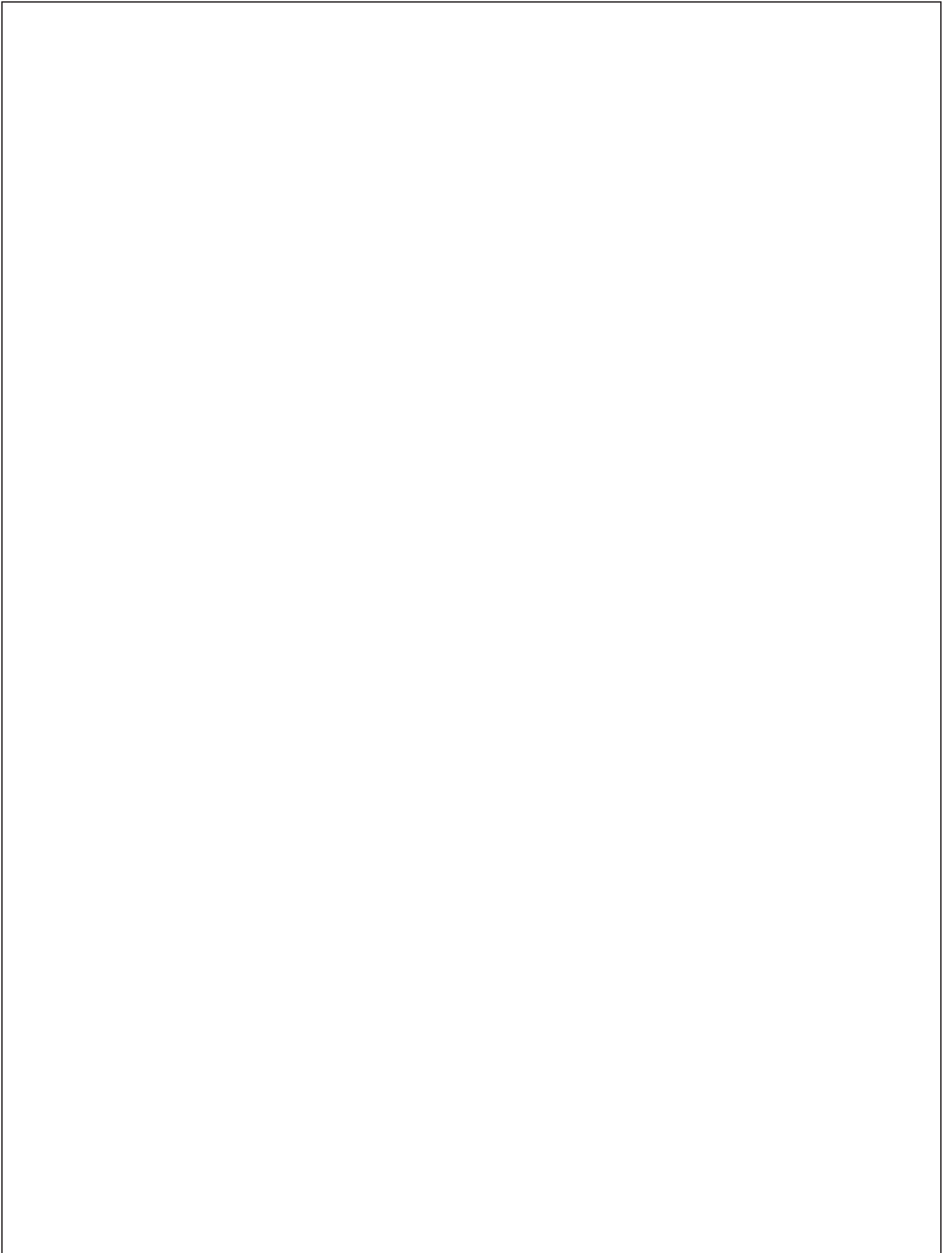



**GILES Food Service Equipment**  
**ISO 9001-2015 Certified**

2750 Gunter Park Drive West • Montgomery, AL 36109 USA  
Phone 334.272.1457 • Fax 334.239.4117 • Phone Toll Free 800.554.4537  
Website: [www.gfse.com](http://www.gfse.com) • Email: [services@gfse.com](mailto:services@gfse.com)

64898  
REV-O  
ECO3582  
02/24/2026  
PRINTED IN USA