

# Operations & Service Manual

GEF Series  
GEF-VH Series



Models: GEF-400  
GEF-560  
GEF-720



Models: GEF-400-VH  
GEF-560-VH



PROVEN & TRUSTED SINCE 1952

ISO 9001 Registered • Committed to Quality

2750 Gunter Park Drive West • Montgomery, AL 36109 USA

Toll Free: **800.554.4537** (USA & Canada Only) Other: **334.272.1457**

Fax: 334.239.4117 • Website: [www.gfse.com](http://www.gfse.com) • Email: [services@gfse.com](mailto:services@gfse.com)

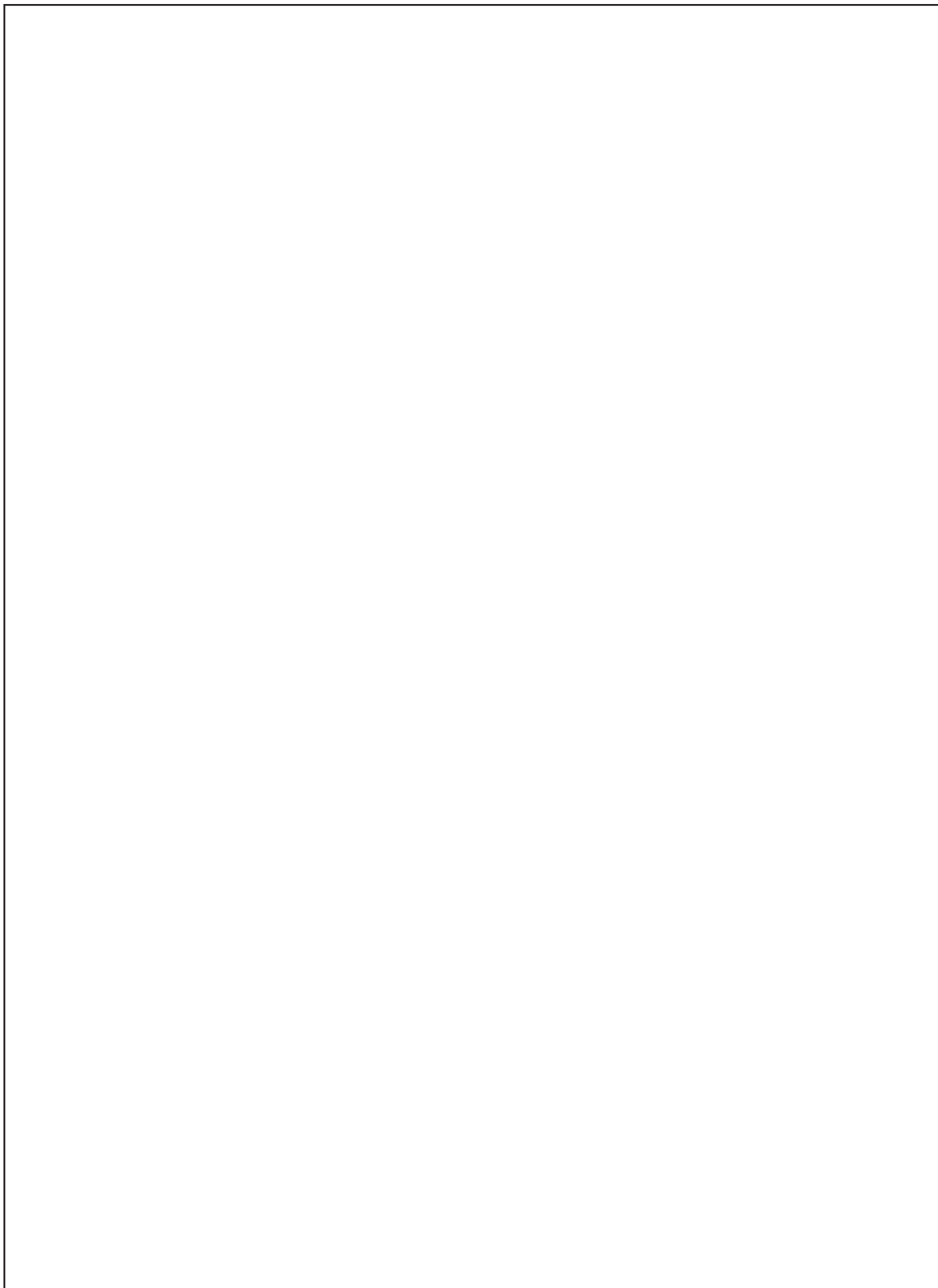



## LIMITED WARRANTY

- Subject to the terms and conditions of this Limited Warranty as herein stated, all Giles Enterprises Inc. (hereafter referred to as "Giles") food service equipment and parts purchased new from an authorized Giles representative are warranted as to defects in material or workmanship for a period of twenty-four (24) months from the date of installation, provided, however, that with regard to labor costs in connection with this warranty, see below. All installations must be made by a qualified installing agency in accordance with all applicable codes and/or regulations in the jurisdiction in which installed. Limited warranty coverage is extended only to the original owner and is void if the unit is resold.
- During the Limited Warranty period, Giles will replace or recondition, at its factory, any part or parts of this unit which Giles inspectors judge defective, provided the unit has been properly installed, subjected to normal usage, and operated and maintained in accordance with specified procedures. This Limited Warranty does not cover cosmetic damage, and damage due to acts of God, accident, misuse, alteration, negligence, abuse, or use of unorthodox repair methods. All parts replaced under this Limited Warranty carry only the unexpired term of this Limited Warranty. Limited Warranty service may be furnished only by an authorized Giles service representative.
- If Limited Warranty service is requested, Giles will dispatch factory-authorized service representatives to inspect, repair, recondition, or replace units of its manufacture with such labor being rendered without cost to owner for twenty-four (24) months from the date of installation. Otherwise, service, including labor and transportation charges or other expenses, in connection with the removal or installation of any part or parts supplied under this Limited Warranty, are specified on the original sales contract between the purchaser and the authorized Giles representative.
- **Failure to use Giles OEM replacement parts and Giles OEM filters may void this Warranty.**
- Giles reserves the right to change or improve its equipment and/or parts in any way without obligation to alter such equipment or parts previously manufactured.
- Giles makes no further warranties, express or implied, including implied warranties of merchantability or fitness for a particular purpose, and has no other obligation or liability not specifically stated herein.
- Repair or replacement as provided under this limited warranty is the exclusive remedy. Giles shall not be liable for any incidental or consequential damages for breach of any express or implied warranty on this product, except to the extent prohibited by applicable law. Any implied warranty of merchantability or fitness for a particular purpose on this product is limited in duration to the duration of this limited warranty.
- Used Giles foodservice equipment or parts, or Giles foodservice equipment or parts not purchased from an authorized Giles representative, carry no warranties, express or implied.

## Safety

Safety Overview .....	vii
Specific Safety Precautions .....	viii

<b>1.</b>	<b>Introduction .....</b>	<b>1</b>
1.1	Construction .....	1
1.2	Standard Features .....	1
1.3	Specifications .....	2
1.3.1	Overall Dimensions: GEF Models .....	2
1.3.2	Overall Dimensions: GEF-VH Models .....	3
1.3.3	Agency Certifications .....	4
1.3.4	Basket Sizes .....	4
1.3.5	Cooking Capacities .....	4
<b>2.</b>	<b>Installation .....</b>	<b>5</b>
2.1	Appliance Location .....	6
2.2	Unpacking .....	6
2.3	Electrical Requirements .....	7
2.4	Electrical Connections .....	9
2.4.1	Conduit Routing .....	9
2.4.2	Service Box Connections .....	10
2.5	Ventilation of Non-Ventless Fryer .....	10
2.6	Ventless Hood Clearances (VH Model) .....	10
2.7	Ventless Hood Fire Suppress System .....	11
2.8	Fusible Link and Gas Cartridge Locations .....	11
2.9	Fire Extinguisher Nozzle and Tank Locations .....	12
2.10	Fire Alarm Connection .....	13
2.11	Changing the Door Swing .....	14
2.12	Finalizing Installation .....	15
2.12.1	Power Test .....	16
2.12.2	Heating Element Test .....	16
2.12.3	Filter Pump Test .....	17
2.12.4	Initial Fryer Cleaning (Boil Out) .....	17
2.12.5	General Initial Cleaning of Fryer & Filter Pan .....	18
2.12.6	Optional KITCHENTRACT™ - Remote Equipment Monitoring .....	18
<b>3.</b>	<b>Overview .....</b>	<b>19</b>
3.1	Control Panel .....	20
3.2	Lower Cabinet Area .....	22
3.3	Filter Pan Assembly .....	24
3.4	Basket & Elevator Assembly .....	26
3.5	Ventless Hood (VH Model Only) .....	28
3.6	Accessories (Included) .....	30
3.7	Accessories (Not Included, Purchased Separately) .....	32

<b>4.</b>	<b>Fryer Operation</b>	<b>35</b>
4.1	Computer Cooking Controller	36
4.1.1	Keys & Functions	36
4.1.2	General Operation - Fryer Controller	38
4.1.3	Manually Setting a Cook Time & Cooking Temperature	39
4.1.4	Working with Menu Item Presets	40
4.1.4.1	Editing a Menu Preset	41
4.1.4.2	Selecting a Menu Preset for Cooking	44
4.1.5	Cooking Cycle - General Overview	45
4.1.6	Other Controller Features	45
4.1.6.1	Manually Operating the Basket Lift	45
4.1.6.2	COOL Mode	46
4.1.6.3	AUTO-COOL Feature	46
4.1.6.4	BOIL OUT Mode	46
4.1.7	User Settings	47
4.1.8	PASSWORD Protection	48
4.1.9	Start-up Procedure	48
4.1.9.1	Start-up Non-Ventless Fryer (GEF)	48
4.1.9.2	Start-up Ventless Fryer (GEF-VH)	49
4.1.10	Controller Errors & Alarms	50
4.1.10.1	Resolving Controller Errors & Alarms	51
4.2	Cooking Procedures	53
4.3	Filtering Used Cooking Oil	58
4.4	Removing Waste Cooking Oil from Fryer	61
4.5	Normal Shutdown	64
4.6	Emergency Shutdown	64
<b>5.</b>	<b>Cleaning</b>	<b>65</b>
5.1	Boil-Out Procedure (Cleaning the Fry Pot)	65
5.2	Cleaning the Filter Pan & Replacing Filter Media	68
<b>6.</b>	<b>Ventless Hood</b>	<b>69</b>
6.1	Filters	69
6.1.1	Ventless Hood Filter Table	69
6.1.2	Baffle Filter Removal	70
6.1.3	Baffle Filter Installation	71
6.1.4	Baffle Filter Cleaning	72
6.1.5	EAC Filter Cell Removal	72
6.1.6	EAC Filter Installation	73
6.1.7	EAC Filter Operation Overview - Status & Alarms	73
6.1.7.1	EAC Filter Cell Cleaning Timer	75
6.1.8	EAC Filter Cleaning	76
6.1.9	Charcoal Filter Removal & Installation	78
6.1.10	Charcoal Filter Maintenance	79
6.1.11	Filter Alarm Chart	79
6.2	Maintenance	81

6.2.1	Monthly Interlock Testing . . . . .	81
6.2.2	Quarterly Hood Cleaning . . . . .	82
6.2.3	Semi-Annual Fire Suppression System Inspection & Service . . . . .	82
6.2.4	Annual Fire Suppression System Inspection & Service . . . . .	82
6.2.5	12-Year Fire Suppression System Inspection & Service . . . . .	82
6.2.6	Maintenance & Service Log . . . . .	83
<b>7.</b>	<b>Troubleshooting . . . . .</b>	<b>84</b>
7.1	Temperature Control System . . . . .	84
7.2	Oil Filtration System . . . . .	87
7.3	Basket Elevator System . . . . .	87
<b>8.</b>	<b>Parts List . . . . .</b>	<b>89</b>
8.1	Parts Ordering & Service Information . . . . .	89
8.2	Control Panel & Front Header . . . . .	90
8.3	Front Lower Cabinet . . . . .	92
8.4	Fry Pot . . . . .	94
8.5	Rear Lower Cabinet . . . . .	96
8.6	Basket Cover & Basket . . . . .	98
8.7	Filter Pan Assembly . . . . .	100
8.8	Front Ventless Hood (GEF-VH Only) . . . . .	102
8.9	Rear Ventless Hood (GEF-VH Only) . . . . .	104
<b>APPENDIX:</b>		
<b>A.</b>	<b>Connecting Optional KITCHENTRAC™ . . . . .</b>	<b>107</b>
A.1	Connecting WIFI Board to Wireless Router . . . . .	107
A.2	Establishing Communication with KITCHENTRAC™ . . . . .	108
A.3	WIFI Components . . . . .	109

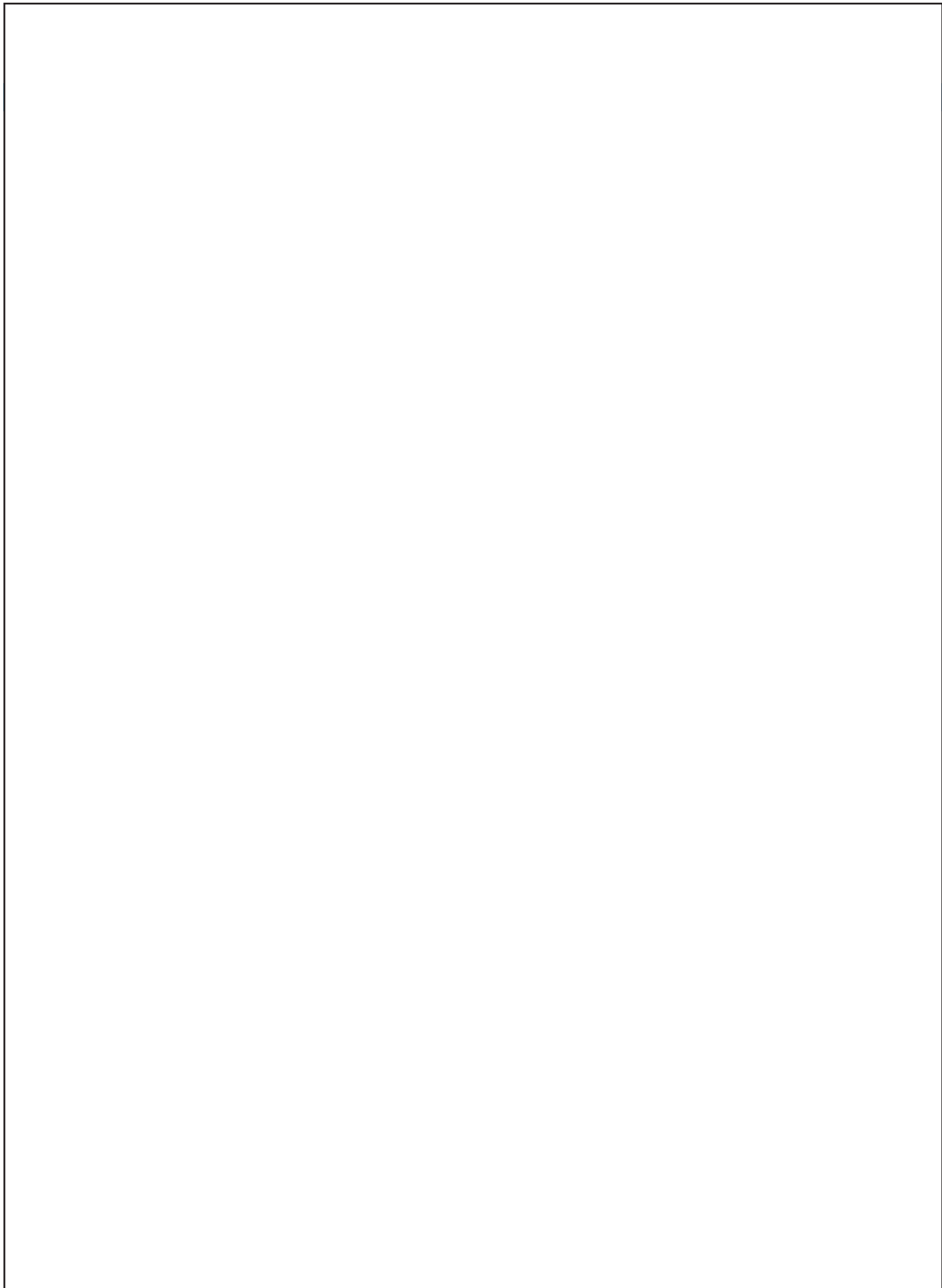

## Safety

### Safety Overview:

The instructions contained in this manual have been prepared to explain the proper procedures for installing, operating and servicing *Giles Model GEF or GEF-VH Series Electric Fryer*.

Throughout the manual, safety precautions are identified by a hazard alert symbols and notifications such as **DANGER**, **WARNING** or **CAUTION**. Alert information precedes the tasks to which it applies. Suggested, recommended, or other noteworthy information is identified as **NOTES**, or will be marked as **IMPORTANT!**. Additionally, certain words are used to indicate a specific meaning, or to add emphasis as follows:

- Shall:** understood to be mandatory.
- Should:** understood to be advisory.
- May:** understood to be permissive.
- Will:** indicates a future event or condition to occur.

 **Hazard Alert Symbols** are used in conjunction with notifications **DANGER**, **WARNING**, or **CAUTION**, to alert users of potential personal injury hazards and/or poor operating practices. Notification will immediately precede the precautionary measures pertaining to avoiding such hazards or practices. Adhere to all information following these symbols to avoid possible injury, or even death. Failure to do so may also void the factory warranty.

 *This product can expose Users to chemicals including lead, nickel, cobalt, aluminum, cadmium, brass, carbon, copper or BPA which are known in the state of California to cause cancer, birth defects and other reproductive harm. For more information go to: [www.p65warnings.ca.gov](http://www.p65warnings.ca.gov).*

### **DANGER**

Indicates an imminently hazardous situation which, if not avoided, will result in serious personal injury, even death.

### **WARNING**

Indicates a potentially hazardous situation which, if not avoided, could result in serious injury, even death.

### **CAUTION**

Indicates a potentially hazardous situation which, if not avoided, may result in minor to moderate injury. This notification is also used as an alert to unsafe practices.

### **CAUTION**

If used without the safety alert symbol, indicates a potentially hazardous situation which, if not avoided, may result in equipment and/or property damage, and may void the factory warranty.

### **NOTE or IMPORTANT!**

Identifies suggested, recommended, or other important information.

**Specific Safety Precautions:**

For your safety, please observe the following precautions when operating or servicing **GEF & GEF-VH Electric Fryers**. Adherence to the following important safety precautions will help users to avoid personal injury and/or damage to the equipment or property.

**⚠ DANGER**

- Before cleaning or performing maintenance, place power switch in the OFF position. Turn OFF power at the electrical panel supplying power to remove all power from the appliance.
- **DO NOT** wash down the fryer interior or exterior with water spray ... not *wash-down safe*.
- Failure to comply with **DANGER** notices will result in serious injury, even death; or damage to equipment and/or property and may void the factory warranty.

**⚠ WARNING**

- Fryer with an integral, ventless/recirculating hood is *not* suitable for every commercial food service application. Failure to fully comply with all site requirements and installation limitations as outlined in the *GFSE Hood Approval Letter and this Manual*, may result in poor or highly unsatisfactory hood performance..
- The equipment must be adequately and properly grounded. Improper grounding may result in electrical shock to users. Always refer to local electrical code to ensure proper grounding of this or any other electrical equipment.
- Check the rating label on the unit to confirm proper power supply required. Consult a professional electrician or service technician to ensure that the installation will comply with the appliance’s electrical requirement and all local codes, and that circuit breakers and wiring are of sufficient rating and gauge to power the appliance load. A wiring diagram is provided. **Appliance must be installed and electrically grounded in accordance with local code, or in the absence of local code, in accordance with the *National Electrical Code, NFPA 70*.**
- Improper installation, adjustment, alteration, service, or maintenance could result in serious injury, even death; equipment and/or property damage; and will potentially void the factory warranty.
- **DO NOT** use or store flammable liquids, or materials that produce flammable vapors, in the vicinity of this or any other appliance!
- **DO NOT (or ALLOW OTHERS to) for any reason, stand or step onto the top of the appliance.** Cooking oil in fryers can be **EXTREMELY HOT (in excess of 330°F [166°C])**. Bodily contact will cause extremely serious injury. Lids used to sometimes cover cooking vats/pots are not designed to, and **WILL NOT**, support the weight of a person.
- Failure to comply with **WARNING** notices could result in serious injury, even death; damage to equipment and/or property; and will potentially void the factory warranty.



### CAUTION

- The appliance must remain in an upright position.
- Exercise care when removing the unit from shipping pallet.
- **DO NOT** operate the appliance unless you completely understand its components and their intended functions (see **Section 3**). Closely follow the presented procedures and instructions in order to avoid damage or malfunction.
- **To avoid personal injury, it is recommended that thermal hand protection (gloves or mitts) be worn while tended the appliance.** Certain parts of the fryer will become very **HOT** during operation ... temperatures inside cabinet may exceed **150°F (65.5°C)**! Exercise caution when operating and cleaning.
- Placing foods containing excessive moisture into hot oil, or attempting to load larger than recommended batch sizes can cause “*surge boiling*” and result in an overflow of **HOT** cooking oil. Exercise due care when loading food and observe how hot oil reacts before continuing.
- Be sure the appliance is positioned in a stable, safe location with the front caster wheel brakes in the locked position. **DO NOT** operate appliance if not secured. Some jurisdictions may require additional special anchoring for this type appliance ... check local codes.
- Allow the appliance to cool for 15-20 minutes before cleaning or servicing.
- This appliance is not intended for use by persons (including children) with reduced physical, sensory, or mental capabilities, or lack of experience and knowledge, unless they have been given adequate instruction and/or supervision concerning its use by a person responsible for their safety.
- Prior to sale for consumption, cooked food products must be maintained at a minimum holding temperature of 150°F (65.5°C), or in accordance with governing health regulations
- **Ventless Hood (VH) Models:**
  - Avoid bending the collection fins or breaking the ionizer wires on the Electronic Air Cleaner (EAC) collector cell. Doing so will prevent the system from working properly, and may cause the fryer to shutdown.
  - After cleaning the collector cell, **DO NOT** attempt to dry it by installing it in the hood and running the fan to force air dry, or by heating the fryer. This could potentially damage the EAC power supply and control system, leading to malfunction and voiding the warranty. The cell filter must air dry at ambient room temperature, preferably overnight. A small fan set to blow through the cell can help expedite drying.
- Failure to comply with **CAUTION** notices may result in minor to moderate personal injury, damage to equipment or property, and potentially void the warranty.

**CAUTION**

- Components exposed on the control panel surface are impact-sensitive. To avoid damage and maintain proper operation, exercise care when working around or using carts/rolling tables near the appliance.
- The control panel contains a high-tech electronic microprocessor controller. **While the front panel is liquid-resistant, it is not completely wash-down safe.** When cleaning, avoid spraying directly with high pressure spray.
- **DO NOT** install the unit near combustible walls and materials. Failure to maintain safe distance may result in fire.
- When cleaning the appliance:
  - **DO NOT** steam clean.
  - **DO NOT** use products containing chlorine, or other corrosive chemicals.
  - **DO NOT** use abrasive products, steel wool or scouring pads.
  - **DO NOT** use oven cleaners.
- **DO NOT** alter, add attachments, or otherwise modify this equipment!
- Failure to comply with **CAUTION** notices may result in damage to equipment or property, and void the factory warranty.

**NOTE:**

- Users must comply with all appropriate state and local health regulations relating to food service operations, and cleaning and sanitization of food service equipment.
- **For Ventless Hood (VH) Models:**
  - **NEVER** attempt to clean and reuse a charcoal filter ... it is a single use, consumable filter.
  - Appliance and plenum discharge nozzles for the fire suppression system have been factory installed and positioned in the proper alignment. **DO NOT MOVE OR ADJUST, except on recommendation of a certified fire protection specialist.**
  - The sound level of the hood while in operation is approximately **65 dB**.

## 1. Introduction

**THANK YOU** for purchasing a *Giles Model GEF or GEF-VH Series Electric Fryer*, manufactured by *GILES Food Service Equipment*; Montgomery, Alabama (USA), hereafter referred to as "*Giles*". Every unit is thoroughly inspected and tested prior to shipment in an effort to ensure that it will operate flawlessly when properly installed. With proper care and maintenance the appliance will provide years of trouble-free service.

To help protect your investment, we recommend that you take a few moments to become familiar with the procedures contained in this manual relating to installation, operation, cleaning, and maintenance. Adherence to these procedures will minimize the future potential for costly appliance downtime and repair expense. Please retain this manual for future reference.

***NOTE: Due to continuing improvements and product enhancements, some of the illustrations shown in this manual might not exactly depict current models.***

### 1.1 Construction

18 & 20 ga. high-grade series stainless steel. Double-wall cabinet structure.

### 1.2 Standard Features

**Computer Controller** - Accurately controls cooking oil temperature and cooking time. Programmable cooking presets for up to 50 menu items. Constantly monitors fryer status & displays operational instructions, warnings and errors, such as **DRAIN OPEN, LOW OIL LEVEL, MAX. ELEMENT TEMP**, etc. Features **BOIL-OUT program, COOL MODE, FORCE FILTER** control, password security, three language selections, and enhanced safety features.

**Automatic Basket Lift** - Automatically lowers basket of product when cook cycle is started ... lifts cooked product from hot oil at the conclusion of the cook cycle.

**Built-in Oil Filtration System** - Fully self-contained system ... when used properly, can help to extend the useful life of cooking oil. Robust 1/2 hp pump ... designed to perform a filter cycle in approximately five (5) minutes.

**Push-To-Start Feature** - After a power any interruption, operator must press [**START**] key on controller to power-up the appliance. This feature will comply with code requirements in some jurisdictions.

#### **GEF-VH Integral Ventless Hood Model Only:**

**Ventless Hood** - Integral, self-contained, type-1, recirculating hood removes grease-laden cooking vapors produced while frying and recirculates cleaned air into the room ... eliminates need for conventional venting to the outside.

***GEF-VH models must be installed only in sites which comply with the specific installation limitations & restrictions, as explained in the Giles Hood Approval (HAL) document.***

**Fire Extinguishing System** - Self-contained, *Ansul® R-102* wet chemical fire extinguishing system protects unit at all times. ***Requires purchaser-provided final field set-up & commissioning by an Ansul distributor/dealer.***

**EAC Cleaning Timer** - Notifies operators when it is time to clean the *electronic air cleaner (EAC) collection cell*. Daily cleaning is important to maintain peak performance of the air cleaning system. The timer system will disable the appliance if cleaning activities are not performed in a timely manner.

1.3 Specifications

1.3.1 Overall Dimensions: GEF Models

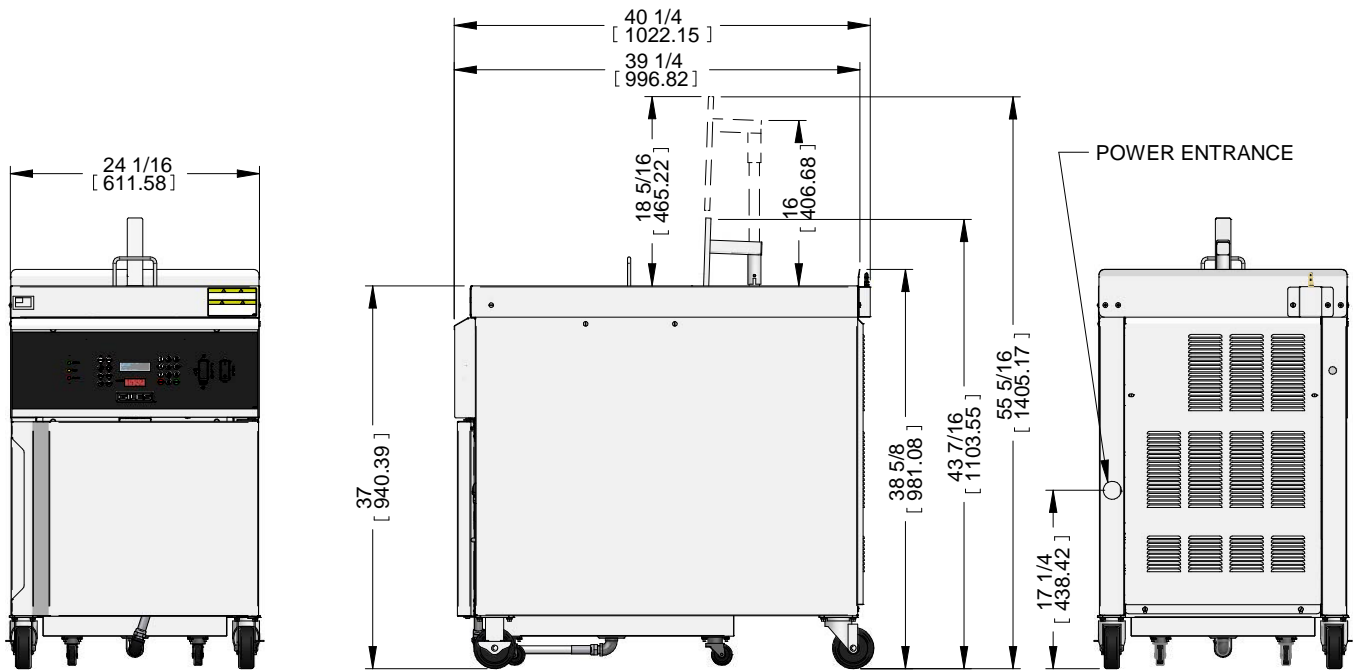
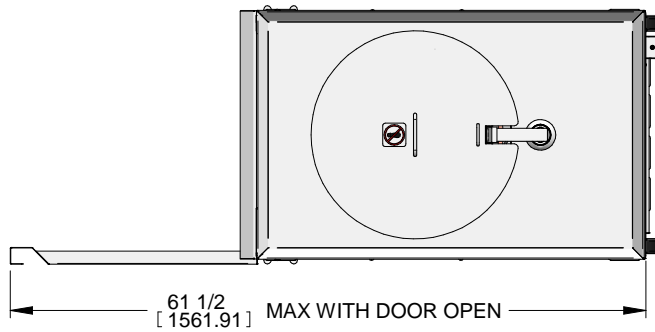

Inches [mm]

## 1.3.2 Overall Dimensions: GEF-VH Models

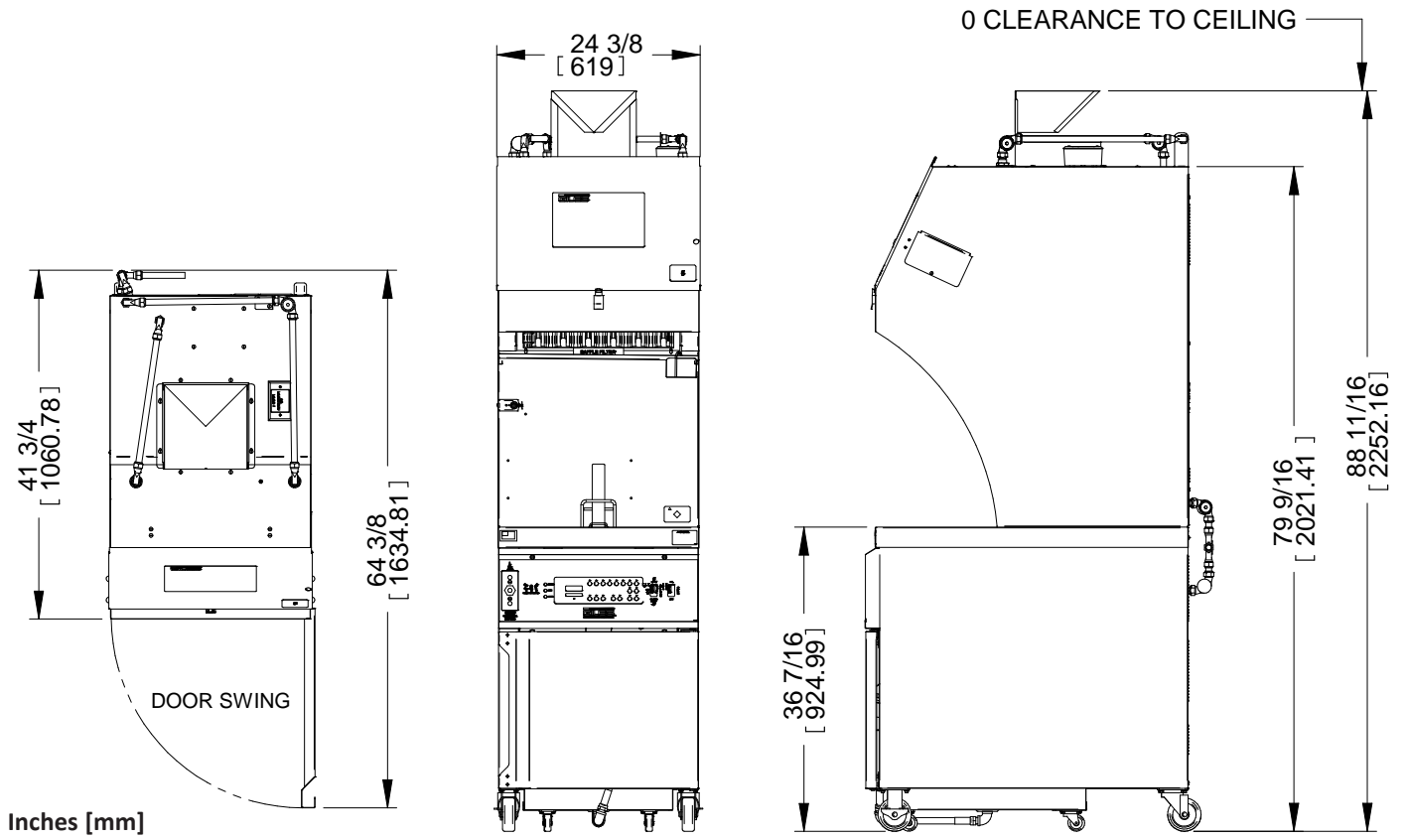

**NOTE:** The appliance is equipped with an exhaust air diverter, requiring zero [0"] clearance to ceiling, or overhead obstructions. It is recommend that some adequate space be provided to allow for easy movement of the appliance, if need.

**1.3.3 Agency Certifications**



GEF-VH models are listed to *UL-KNKG (-7 for Canada)* complying with *ANSI/UL-197 & ANSI/UL-710B*

**1.3.4 Basket Sizes**

Model	Basket Size		Volume
	Diameter: in[mm]	Depth: in[mm]	Cubic inch [Cu m]
GEF-400 & 400-VH	12-3/8 [314.2]	10-1/4 [260.4]	1,231.8 [.020]
GEF-560 & 560-VH	14-3/4 [374.7]	10-1/4 [260.4]	1,751.5 [.029]
GEF-720	14-3/4 [374.7]	12-3/4 [323.9]	2,178.6 [.036]

**1.3.5 Cooking Capacity**

Model	Cooking Oil Capacity		Product Capacity (*Chicken)
	Lbs [kg]	Gal [l]	Lbs [kg]
GEF-400 & 400-VH	45 [21]	5.8 [21.9]	14 [6.3]
GEF-560 & 560-VH	60 [27]	7.8 [29.5]	19 [8.6]
GEF-720	75 [37]	9.7 [36.7]	24 [10.8]

*\* 8-way cut, bone-in*

## 2. Installation

This section summarizes procedures necessary for proper equipment installation. To help avoid personal injury or equipment damage, adhere to all of these recommended procedures.

**Installation expenses (materials & labor) are completely the purchaser's responsibility.** Generally, it is advisable to engage the services of a professional commercial kitchen equipment specialist and a licensed electrician to assist with the details of installation. Additionally, a qualified HVAC contractor may be required when installing the ventless GEF-VH model. Call *Giles Technical Support @ 800.554.4537*, if assistance is required.

***GEF-VH Fryer:*** The hood section is equipped with a self-contained *Ansul® R-102 wet chemical fire suppression system* (piping, conduit, nozzles, Automan release mechanism, detector link brackets, fire damper & chemical tank). Field set-up and commissioning must be completed by an authorized *Ansul Distributor/Dealer* including, but not limited to, installation of proper fusible detector links & cabling, filling and installing the provided wet chemical suppressant tank, installation of a remote manual activation station, installing compressed gas discharge cartridge, testing, certifying and arming the system. ***All expenses (parts & labor) necessary for field set-up is the responsibility of the customer and is not included with fryer purchase.***

### 2.1 Appliance Location

#### **IMPORTANT!!**

Before installing a GILES fryer with Integral Recirculating/Ventless Hood, ensure that; A). all necessary approvals from local code authorities have been obtained and B). the installation site complies with the specific requirements and limitations outlined in the *GFSE Recirculating/Ventless Hood Approval Letter (HAL)*. The HAL is available for review or download at [www.gfse.com](http://www.gfse.com) under the *SUPPORT* tab in *VENTLESS DOCUMENTS*.

To ensure satisfactory performance of the hood section after installation, the intended site **MUST** comply with minimum requirements for kitchen size (>300 sq ft), ceiling height, fresh outdoor air make-up, room air exchange rate, supplemental exhaust ventilation, clearances, etc. as stipulated in Giles' *Hood Approval Letter*.

- **MAXIMUM** of 1 integral fryer/hood per 300 sq ft of commercial kitchen space.
- Fresh outside air make-up must be equal to a **MINIMUM** of 15 complete room air exchanges per hour.
- Giles makes no representations as to the proper design or layout of an establishment in which the ventless hood will be used. Further, Giles does not perform site inspections prior to installation of any of its units.
- When operating, the hood produces a sound level of approximately 65 dB.

#### **CAUTION**

- **DO NOT ALTER, ADD ATTACHMENTS OR OTHERWISE MODIFY THIS EQUIPMENT.**
- **Failure to comply with installation requirements as specified by the *Giles Hood Approval Letter* will void the factory warranty.**

**2.1 Appliance Location - continued**

1. The appliance and surrounding area must be free and clear of combustible materials. *GEF fryer = 3" [7.6 cm] ... GEF-VH fryer = 18" [46 cm].*
2. Allow adequate space for easy access for operation and service.
3. Be certain that available electrical service, wire & circuit breakers, in the intended location complies with voltage and amperage rating required to power the appliance.
4. Be sure unit will be installed in a stable position and will not unintentionally move. The fryer has locking brakes on front caster wheels ... be sure they are locked when installation is complete. Some jurisdictions may require additional special anchoring of the appliance ... check local codes.
5. **Ventless Hood Model Only:**
  - a. Hood exhausts = **510 to 680 CFM**
  - b. Average temperature of exhausted air from the hood, after four (4) hours of continuous frying, is approximately **90°F (32°C)**.
6. This appliance is to be installed, operated and maintained in accordance with the **Standard for Ventilation Control, and Fire Protection of Commercial Cooking Operations, NFPA 96.**

If there are questions concerning suitable location of the appliance, contact **Giles Technical Support** at **800.554.4537** or email **services@gfse.com**.

**2.2 Unpacking**

The fryer is shipped on a wooden pallet; secured with high-tensile plastic strapping and enclosed by a wooden crate framework. The entire unit is wrapped in machine-applied stretch film.

**⚠ CAUTION**

- The appliance must remain in an upright position during the unpacking process.
- Exercise care when removing the wooden crating framework from around the unit.
- Units are **very heavy**. Use extreme care and appropriate handling equipment and/or sufficient manpower when lifting or moving the equipment.
- Failure to comply with these **CAUTION** notices may result in minor or moderate injury, equipment or property damage, and void the factory warranty.

**IMPORTANT!**

If crate exhibited evidence of damage or mishandling, immediately inspect the unit and all accessory items and notify the freight carrier of any damages. Typically it is the purchaser's responsibility to file and negotiate freight damage claims.

## 2.2 Unpacking - continued

1. Carefully cut and remove the shipping wrap and strapping. Remove and set aside all auxiliary items that are packed with the unit. Some items may be found packed in the *Filter Pan* inside fryer cabinet. Keep all of these items in a secure place for future use.
2. Use appropriate tools and work practices to remove the wooden crating from around the unit.
3. Carefully remove the appliance from the shipping pallet. The unit is extremely heavy, GEF models weigh more than **300 lbs [136 kg]**; GEF-VH models more than **500 lbs [227 kg]**.



Great care should be taken when lifting or moving the unit to prevent personal injury or equipment damage. Use appropriate handling equipment or sufficient manpower. **IMPORTANT! Be aware that the GEF-VH model is top-heavy and can easily tip over if a floor obstruction is encountered.**

### IMPORTANT!

Giles is not liable for damages to the unit caused by use of improper material handling equipment or poor work practices, or for personal injuries or property damage which may be incurred during installation of the equipment. Installation is the sole responsibility of the purchaser, unless previous arrangements have been made in writing.

## 2.3 Electrical Requirements

### CAUTION

- Fryers must be properly grounded in **accordance with local code, or in the absence of local code, with the National Electrical Code, ANSI/NFPA 70**. Improper grounding may result in electrical shock to users. Check local electrical code to ensure proper grounding.
- Always consult a professional electrician, or other qualified service technician, prior to installation to ensure that electrical circuits are of sufficient rating for the appliance load.
- **GEF Fryers** are manufactured for the various voltage/Hz/phase shown on **Table 2.3 below**. Check the serial/data label inside the cabinet, or attached to the rear panel to determine the electrical service required.

Table 2.3 Electrical Requirements								
Model	Voltage	Hz	Ph	kW	Amps			Breaker Required
					L1	L2	L3	
GEF-400	208	60	1	10.0	48	48	--	60
	208	60	3	10.0	29	29	29	40
	240	60	1	10.0	42	42	--	50
	240	60	3	10.0	25	25	25	35
	380	50	3	9.6	14	14	14	20
	415	50	3	10.0	14	14	14	20
GEF-400-VH	208	60	1	10.4	50	50	--	60
	208	60	3	10.4	30	30	30	40
	240	60	1	10.4	44	44	--	60
	240	60	3	10.4	26	26	26	35
	380	50	3	9.97	15	15	15	20
	415	50	3	10.4	15	15	15	20
GEF-560	208	60	1	15.0	72	72	--	100
	208	60	3	15.0	43	43	43	60
	240	60	1	15.0	63	63	--	80
	240	60	3	15.0	38	38	38	50
	380	50	3	14.8	21	21	21	30
	415	50	3	15.0	21	21	21	30
GEF-560-VH	208	60	1	15.4	74	74	--	100
	208	60	3	15.4	44	44	44	60
	240	60	1	15.4	64	64	--	80
	240	60	3	15.4	38	38	38	50
	380	50	3	14.8	21	21	21	30
	415	50	3	15.4	22	22	22	30
GEF-720	208	60	3	20.0	58	58	58	80
	240	60	3	20.0	49	49	49	60
	480	60	3	20.0	25	25	25	35
	380	50	3	19.2	28	28	28	35
	415	50	3	20.0	28	28	28	35

## 2.4 Electrical Connections

**NOTE:**

Electrical installation materials (breakers, conduit, fittings, wire, etc.) and labor shall be supplied by the customer. Work should be performed by a professional electrician, or service technician.

Installation must comply with all local code requirements. Giles shall not be responsible for code compliance with regard to installation and use of this appliance.

1. As needed, install appropriate sized circuit breaker in main electrical panel. See **Table 2.3**.
2. Connect 1-1/4" flexible conduit from main electrical panel to the appliance. Attach conduit to rear of the cabinet with appropriate conduit fittings. Allow enough length so that the fryer can be moved easily for cleaning and servicing. See **Figure 2.4.1**.
3. Open cabinet door and remove cover from service entrance box. See **Figure 2.4.2**.
4. Route appropriately sized power wires from the circuit breaker in the main panel through the wire chase inside cabinet wall to the front service box.
5. Connect power wires to the appropriate terminal blocks inside the service box and reinstall cover. See **Figure 2.4.2**.

**NOTE:** On later models, the service box will also contain DIN mount fuse holders & fuses. Confirm that fuses are installed and secure.

### 2.4.1 Conduit Routing

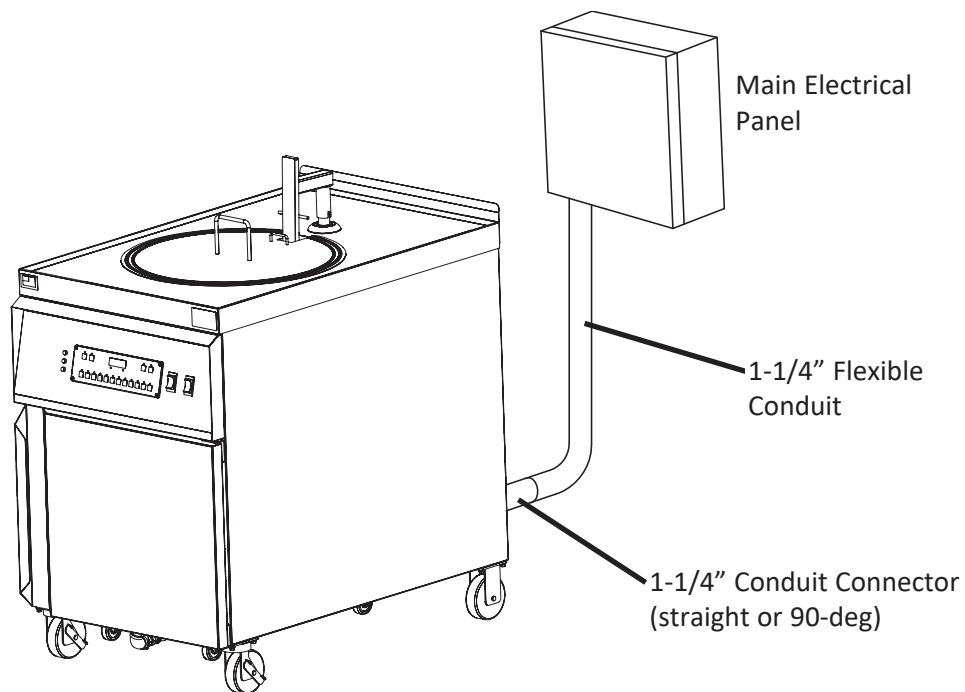

2.4.2 Service Box Connections

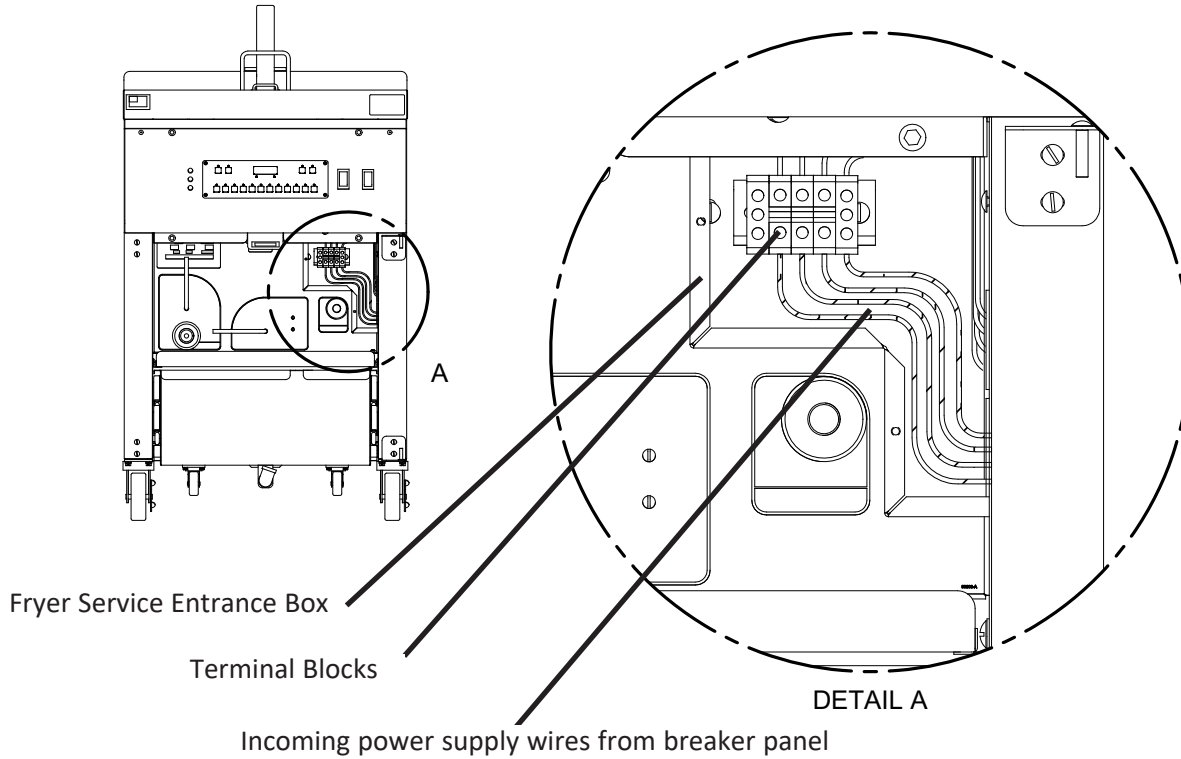

2.5 Ventilation of Non-Ventless Fryer

**NOTE:**  
Guidelines and codes for ventilation system requirements differ from locale to locale. Always consult the local **Authorities Having Jurisdiction (AHJ)** to ensure compliance.

Consult a professional ventilation or HVAC company for assistance in determining whether existing systems are sufficient to accommodate this equipment, or in designing a ventilation hood system to comply with code requirements.

2.6 Ventless Hood Clearances (VH Model)

GEF Ventless Hood fryers are equipped with an exhaust air diverter that directs exhaust air horizontally (sides and rear). The minimum clearance from the top of the diverter to the ceiling is 0" [0 mm], however it is recommended that adequate space be provided to allow easy movement of the unit if required. The area around the sides and rear of the diverter must remain free of obstruction to allow proper air flow.

**DO NOT attach any additional ductwork the hood exhaust in an attempt to redirect airflow to another area. The resulting back-pressure created will reduce hood capture, causing poor or unsatisfactory performance.**

## 2.7 Ventless Hood Fire Suppression System

The fire suppression system in the Ventless Hood fryer is an **Ansul® R-102 Restaurant Fire Suppression System (UL-197 listed)**. The system is mechanically activated which automatically provides constant protection against accidental fire and self-contained, including piping, discharge nozzles (appliance/plenum), fusible link brackets, fusible link cable conduit, Automan release mechanism, fire damper, 1.5 gal. tank and a built-in manual activation station.

**Final field set-up and commissioning of the system *must* be performed by an authorized ANSUL® agent in accordance with the appliance’s listing and shall include charging with suppressant chemical, installation of fusible links + cable, installing compressed gas firing cartridge, testing, certifying and arming. Some jurisdictions may require that an additional, remotely located, manual activation pull station be installed.**

**Fryer WILL NOT heat until the fire system is properly armed.**

**Expenses associated with field set-up and commissioning of the fire system are NOT included with purchase and shall be the responsibility of the purchaser.**

## 2.8 Fusible Link and Gas Cartridge Locations

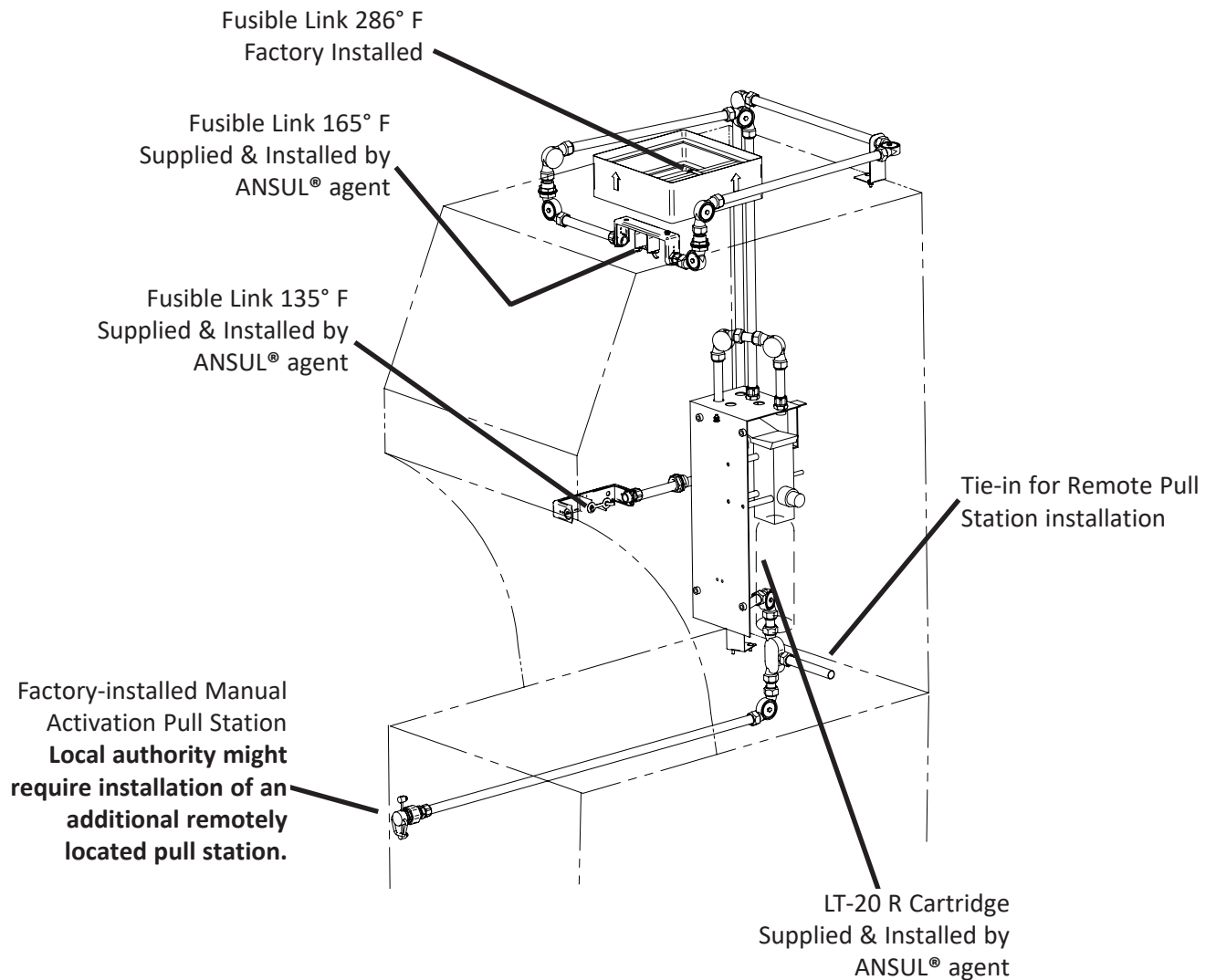

2.9 Fire Extinguisher Nozzle and Tank Locations

All extinguisher system discharge nozzles have been factory installed and aligned in the proper position. **DO NOT MOVE OR ADJUST**, except on advice of a fire protection specialist.

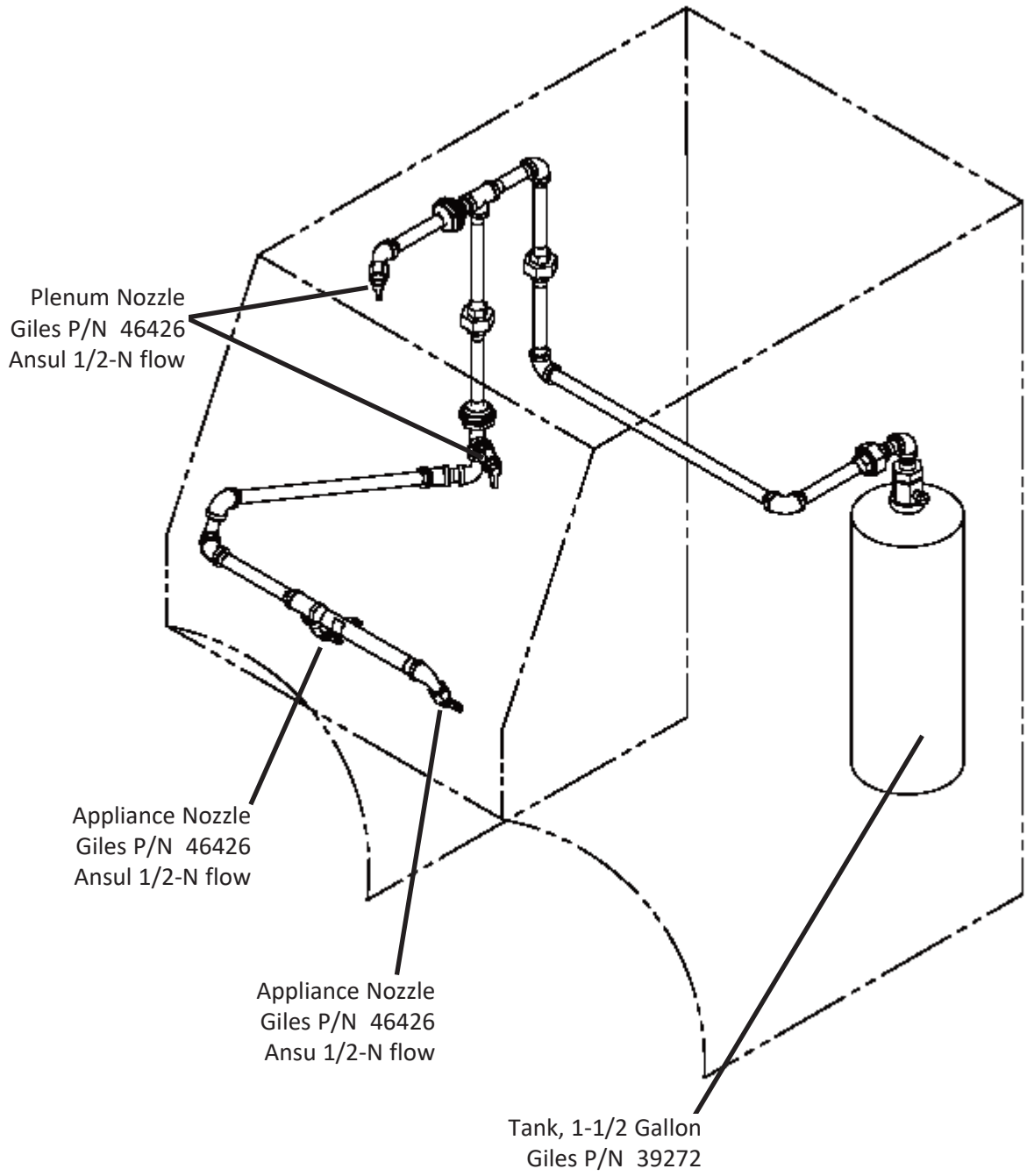

**NOTE:**

Tank is not factory-installed. Packed in separate carton and must be filled and installed by *Ansul*® service technician.

## 2.10 Fire Alarm Connection

Connects fire suppression system to the building fire alarm system for detecting activation of the fire extinguishing system.

### Fire Alarm Connection:

1. Remove cover on Fire Alarm Tie-In Box and install appropriately sized conduit and wire to the facility's fire alarm system. Allow enough length such that the appliance can be moved for access when cleaning and servicing.
2. Make appropriate connections and reinstall cover.

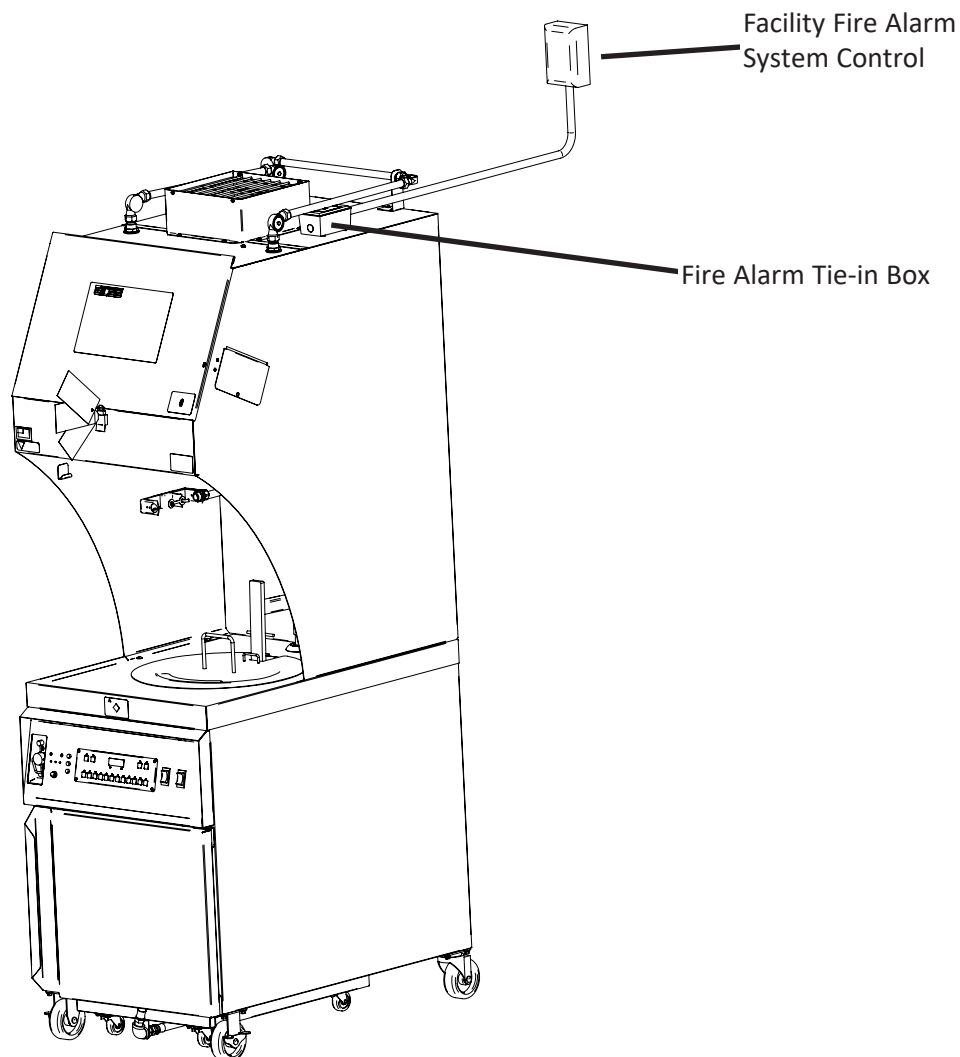

**2.11 Changing the Door Swing**

Certain situations may require that the door swing direction be reversed to allow easier access to the lower cabinet. This procedure is described below.

1. Turn OFF fryer power.
2. Remove (4) screws ① on the left side of the fryer cabinet and retain.
3. While supporting door; remove screws ② (2-top & 2-bottom) holding hinges to the cabinet; remove door along with the hinges. Retain the plastic washer ③ from the bottom hinge.
4. Flip the top hinge ④, move to the bottom corner on the opposite cabinet side and attach with screws removed in Step-1 ... do not tighten. Place the saved plastic washer ③ onto the hinge pin.
5. Flip the cabinet door and hang on the hinge pin.
6. Flip the bottom hinge ⑤, move it the top corner on opposite side and insert pin into top of door. Attach hinge to cabinet with screws removed in Step-1 ... do not tighten.
7. Check door swing and levelness; adjust as needed. Securely tighten all hinge screws.
8. Install (4) screws (2-top & 2-bottom) removed in Step-3 to fill holes on right cabinet side.
9. Power up fryer.
10. If desired, order a new **Quick Reference Door Label (Part No. 60802) ⑥** and apply over existing label. Available through a *Giles Food Service Equipment* dealer or service agent.

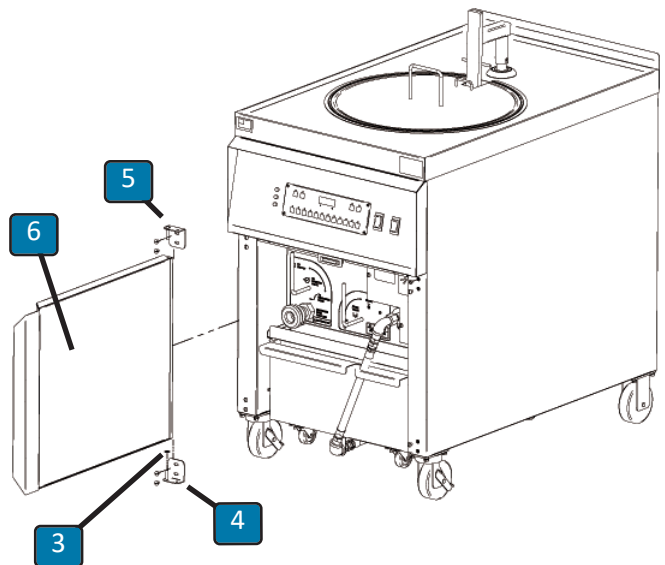
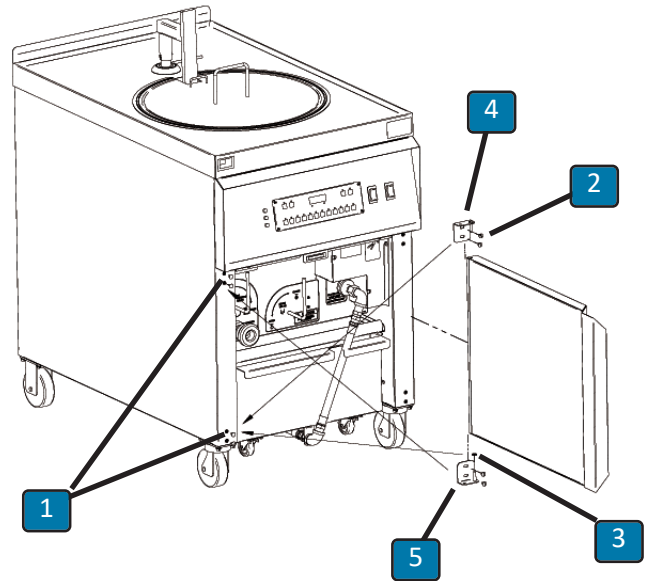

## 2.12 Finalizing Installation

Every effort is made to ensure that new *GILES fryers* are in perfect operating condition when received and installed ... each one has passed rigorous quality control testing and inspection prior to shipment. After fryer installation is complete, to ensure that it has been properly installed and will operate as expected when placed into service, we recommend that the following simple tests be performed to check basic functionality of systems and to prepare the appliance for first use.

### **CAUTION**

Before proceeding, please refer to *Section 3* and become familiar with various controls, systems and functions. After fully understanding this information, perform the following steps precisely to avoid possibly equipment damage.

#### **BEFORE BEGINNING:**

- As necessary, remove basket and filter pan from fryer.
- As applicable, on control panel set switches (*POWER & SELECTOR*) in the [OFF] positions.
- Inside cabinet, confirm that *DRAIN VALVE* is [CLOSED] & *OIL DIVERTER VALVE* is in [TO FRYPOT] position
- If any of the following tests fail to produce the described result, consult *Section 6, Troubleshooting*, or contact *GILES Technical Service at 800.554.4537* for assistance.

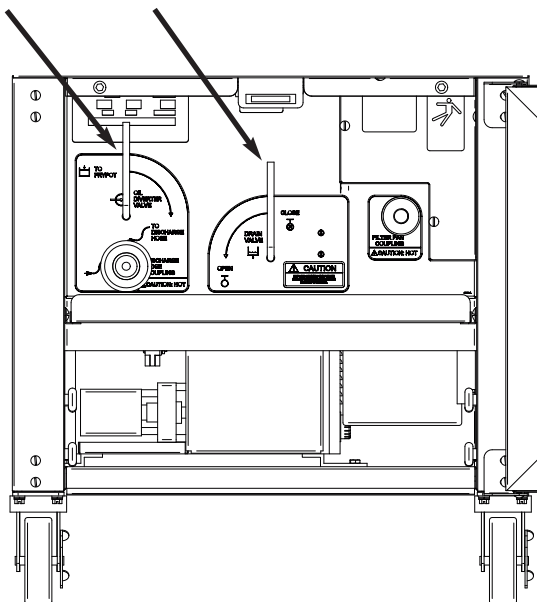

**2.12.1 Power Test**

This test confirms that the unit is properly receiving power.

1. Confirm that circuit breakers supplying power to unit are ON. *If a disconnect switch is installed between electrical panel and fryer, be sure that it is in the ON position.*
2. Place **POWER** switch in [ON] position. Green **POWER** light turns ON and the computer controller powers up. When alarm signal sounds after power-up, press [ALARM] key to silence, leave **POWER** switch [ON] and proceed to **Section 2.12.2**.

If the **POWER** light does not turn ON and/or controller does not power-up, refer to **Section 7.01, Troubleshooting Procedures**.



**2.12.2 Heating Element Test**

The following test confirms that heating elements are being energized.

**CAUTION** DO NOT touch heating elements. They quickly become very hot and contact with bare skin will result in severe burn injury.

1. The message "**POWER FAILURE ... PRESS [START] TO ENTER PREHEAT**" should be shown on *upper display* ③. Be sure **SELECTOR** switch is in [OFF] position.
2. Press the [START] key and controller enters **PREHEAT**. Menu item info & temp setpoint appear on the *upper display* and controller will call for **HEAT ...** small red indicator adjacent to *lower display* turns ON.
3. Liberally dampen heating elements ① with a wet sponge or towel ... leave visible moisture.
4. Place the **SELECTOR** switch ④ in [COOK] position. The amber **HEAT** light on control panel should turn ON. Leave switch in [COOK] for **NO MORE THAN 10 -15 SECONDS** and then return to [OFF]. Leave power ON.
5. The moisture on the elements should quickly dry and heat should be felt rising from the pot.

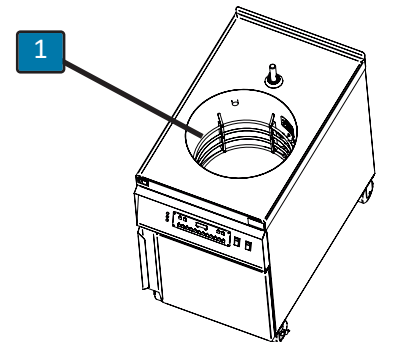

If no heat can be felt, or elements do not get hot enough to evaporate the moisture, refer to the troubleshooting procedures in **Section 7.1**, otherwise proceed to **Section 2.12.3**.

## 2.12.3 Filter Pump Test

The following test confirms that the filter system pump is operating properly.

1. Confirm **POWER** switch is **[ON]**.
2. Open cabinet door. *If necessary, disconnect and remove filter pan .*
3. Firmly press the palm of the your hand over the filter pan hose coupling (2).
4. While covering the opening with your hand, set the **SELECTOR** switch (3) to the **[FILTER PUMP]** position. Filter pump should start running ... if suction is felt, it is operating correctly. Return switch to **[OFF]**. **ONLY allow pump to run long enough to check for suction.**

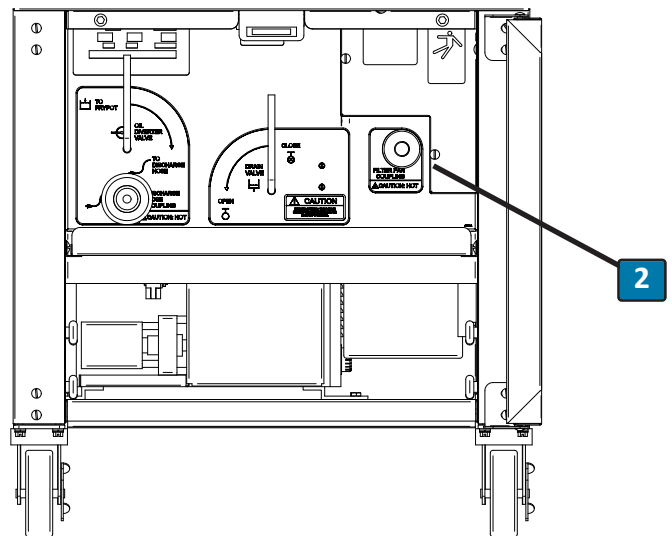

If no suction is felt or if air is blowing out of the fitting, refer to the troubleshooting procedures in **Section 7.2**, otherwise proceed to **Section 4.5**.

## 2.12.4 Initial Fryer Cleaning (Boil Out)

### IMPORTANT!

Before using the appliance for the first time, perform a *Boil-Out Procedure* on fryer pot. This process removes residue which may remain from manufacturing processes, or dirt and debris that may have accumulated during warehousing and shipment. For details concerning the *Boil-Out Procedure*, see **Section 5.01**.

### 2.12.5 General Initial Cleaning of Filter Pan & Fryer

To remove residue which may remain from manufacturing processes, or dirt and debris that may have accumulated during warehousing and shipping, disassemble and thoroughly clean all parts of the filter pan. For details, see **Section 5.02, Cleaning the Filter Pan & Refreshing Filter Media**.

Wash all accessory items included with the fryer (basket, basket carrier arm, utensils, tools, etc) in warm soapy water, rinse and allow to dry completely.

Inspect unit for any of the adhesive plastic protective film which may remain on sheet metal surfaces. Some film is typically left in place as added protection during storage and shipment. Remove all such material and clean the entire exterior of the unit with a good quality stainless steel cleaner/polish. **DO NOT use cleaners that are abrasive or contain caustic chemicals.**

### 2.12.6 Optional KITCHENTRAC™ Remote Equipment Monitoring



If your new equipment is factory-equipped with **optional Giles' KITCHENTRAC™** remote monitoring, an account must first be created before the feature can be used. A monthly server hosting fee will be required to use the service.

After appliance installation is complete and an account has been created, the appliance must be connected to the **KITCHENTRAC™** server via your establishment's local *wifi network*. A wireless router providing a continuous open connection to the internet and located within range of the monitored appliance is required.

A detailed **WiFi Connection Manual (Form #66313)** should have been packed with the unit. Before the monitoring service is active, the steps outlined must be completed. Additionally, **Appendix A** in the back of this manual also explains the connection & pairing process.

Once the connection process has been completed, you will be able to monitor appliance performance, productivity, menu trends, operational status, and a multitude other analytics by simply logging-in to the **KitchenTrac™** website from any computer or remote device (smart-phone, laptop, or tablet).

---

Installation is now complete and the appliance is ready for use. Before attempting to use it for the first time, please carefully read the remainder of this manual to become familiar with all controls, functions, operational procedures and the necessary maintenance & cleaning activities. Adhering to the methods and processes described here will help keep your new **GILES** fryer performing flawlessly for many years.

## 3. Overview

The following section is a brief overview of the components, functions, and accessories of *Giles GEF and GEF-VH Series Electric Fryers*. Please review this section carefully before attempting to operate the appliance.

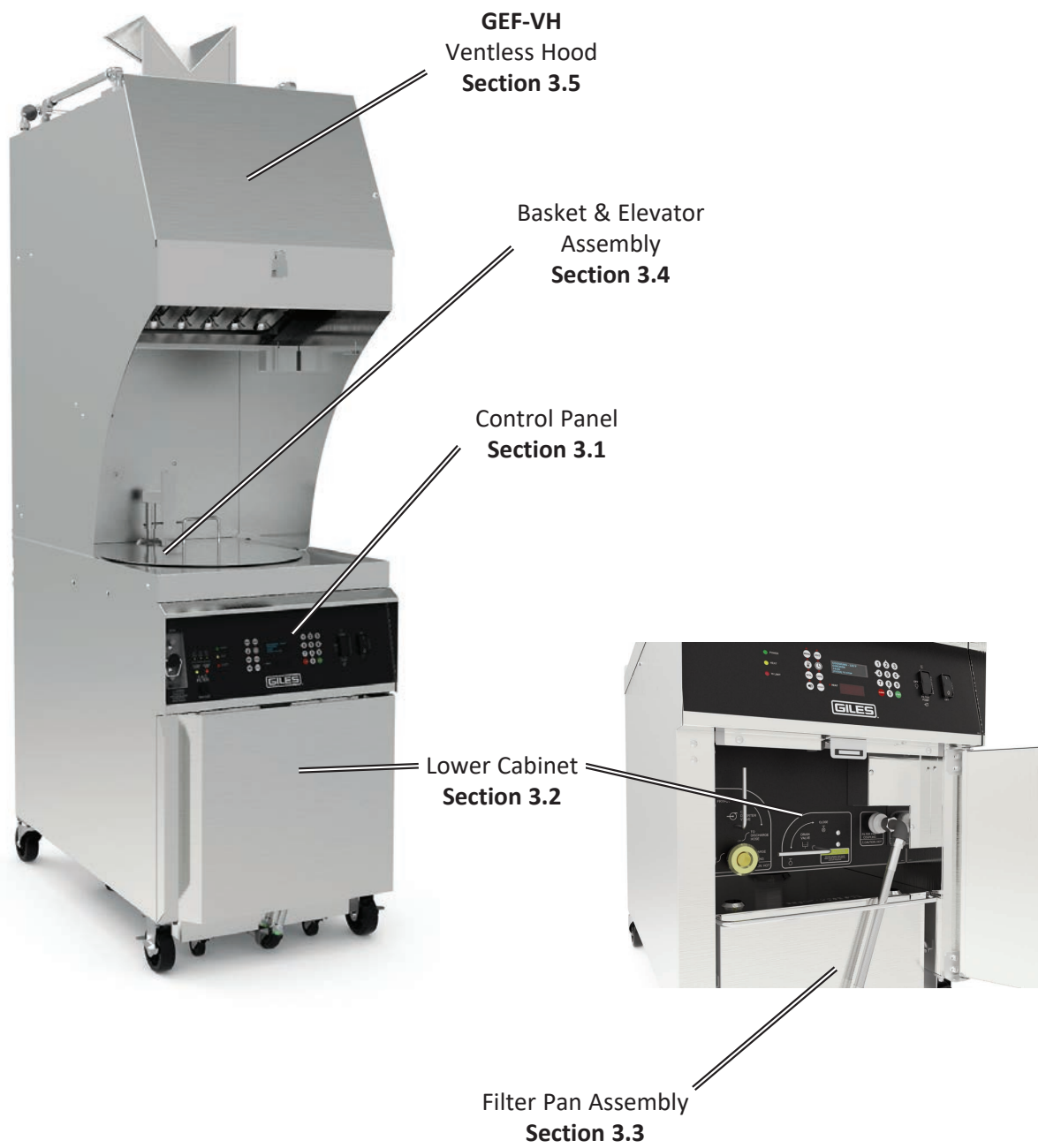

3.1 Control Panel



\* Ventless Hood (VH) Models Only

## 3.1 Control Panel

Item	Description	Function
1	<b>POWER</b> Switch	Turns fryer power <b>ON/OFF</b> . Press top portion to place in <b>[ON]</b> position for operation.
2	<b>SELECTOR</b> Switch	3-position switch selects fryer mode ... <b>[COOK • OFF • FILTER PUMP]</b> . Heating elements only operate when in <b>[COOK]</b> position. Place in <b>[FILTER PUMP]</b> position to run filter pump. Center position is <b>[OFF]</b> .
	Computer Controller	Controls & monitors fryer functions, oil temperature, cook time, etc. Stores up to 50 programmable Menu Item cooking presets. Displays status, operational messages, errors and alarm conditions.
4	<b>HI-LIMIT</b> Indicator	Red high-limit light illuminates when the overheating safety thermostat turns OFF power to heating elements. Should this light come on, discontinue operation and refer to the <i>Troubleshooting Section</i> . <b>NEVER COOK IN A FRYER THAT CONTINUES TO GIVE A HI-LIMIT ALARM!</b>
5	<b>HEAT</b> Indicator	Amber light illuminates when heating elements are energized. When set-point temperature is reached, the light turns OFF. Light will cycle ON and OFF during normal operation.
6	<b>POWER</b> Indicator	Green light is ON whenever the <b>POWER</b> switch is in the <b>[ON]</b> position.
*7	<b>ON</b> L.E.D. Indicator	The <b>[ON]</b> indicator illuminates when the <i>Electronic Air Cleaner (EAC)</i> power supply is ON. The only light ON during normal operation.
*8	<b>WASH &amp; CHECK</b> L.E.D. Indicators	When one of these lights is ON, there is a problem with the EAC system and indicates it has <i>stopped</i> cleaning the air. The cell is either excessively dirty, not making good contact, damaged, or shorted out. <b>IMPORTANT! Do not rely upon these indicators as a notification for routine cleaning; EAC cell must be cleaned daily to maintain peak performance and to extend the useful life of charcoal filters.</b>
*9	Fire Extinguisher Manual Pull Handle	Pulling this handle will manually activate the fire suppression system. The extinguishing system also activates automatically in event of fire.
*10	EAC Cleaning Timer <b>[CHANGE SOON]</b> Indicator	Turns ON when timer enters <b>[WARNING MODE]</b> , indicating that the EAC cell needs to be cleaned within the next <b>24 hours</b> .
*11	EAC Cleaning Timer <b>[CHANGE NOW]</b> Indicator	Turns ON when timer enters <b>[TIMEOUT MODE]</b> , indicating that the maximum time between cleanings has expired. Cell must be cleaned immediately. Power to fryer heating elements will be turned OFF until cleaning is performed, then timer will automatically reset.
*12	EAC Cleaning Timer <b>[SNOOZE]</b> Button	Pressing button, after <b>[TIMEOUT]</b> is active, returns timer to <b>[WARNING MODE]</b> and allows fryer to be used for <b>two (2) additional hours</b> . Only two (2) <b>[SNOOZE]</b> periods are available. Afterward, power to fryer heating elements will be locked-out until cell is cleaned.

\* Ventless GEF-VH models Only

3.2 Lower Cabinet Area



Due to continuing improvements and product enhancements, illustrations might differ slightly from actual unit.

## 3.2 Lower Cabinet Area

Item	Description	Function
1	Diverter Valve Handle	Directs filter pump discharge to either the fry pot or to the <i>Waste Oil Discharge Hose</i> .
2	Quick Coupling - Oil Discharge Hose	Connects the <i>Waste Oil Discharge Hose</i> to fryer plumbing when removing waste oil from fryer.
3	Drain Valve Handle	Operates the fry pot <i>Drain Valve</i> . Always be sure that valve is closed prior to adding cooking oil or water for boil out solution. <b><i>As a safety precaution, heating elements are disabled if valve is not completely CLOSED.</i></b>
4	Quick Coupling - Filter Pan Hose	Connects the <i>Filter Pan Assembly</i> to the fryer on-board oil filtration system.
5	Filter Pan Assembly	Collects oil when drained from pot. Contains filter media for filtering and reconditioning cooking oil after use.
6	Filter Pan Cover	Helps minimize splash when hot oil is drained into the <i>filter pan</i> . Helps safeguard against foreign material contamination of oil during the filtering process. Sits loosely atop filter pan and is easily removed for cleaning.
7	Cabinet Door	Provides access to lower fryer cabinet & filter pan. If needed, swing of the door is field reversible.
8	Door Magnet	Keeps door closed during operation
9	Electrical Service Box	Contains terminal blocks for connecting incoming power supply wiring. Also houses fryer fuses behind a small secondary cover.

3.3 Filter Pan Assembly



\* Not included, Optional Item

Due to continuing improvements and product enhancements, illustrations might differ slightly from actual unit.

## 3.3 Filter Pan Assembly

Item	Description	Function
*1	Crumb Screen <b>(Optional)</b>	Captures large crumbs and other cooking residue as used cooking oil is being drained into filter pan.
2	Hold-down Frame	Holds and seals the filter media in the bottom of the Filter Pan.
3	Filter Paper	Standard paper filter media ... filters fine particles of sediment from the cooking oil during the a filter cycle. One (1) piece of paper media must be used for proper filtering. A filter aid product such as <i>Giles Filter Powder</i> should also be used to recondition the oil.
4	Hold Down Levers (4)	Locks the hold-down frame in position.
5	Filter Pan Hose Quick Coupling	Connects filter pan to the on-board oil filtration system. The hose must be disconnected for filter pan removal.
6	Filter Pan	Collects and filters used cooking oil drained from the fry pot. Removable for cleaning and refreshing of filter media. A perforated screen is permanently attached in the pan bottom to support filter media, and should media become torn, prevents larger debris from entering the filter pump. <b>THIS IS NOT A FILTER ... FILTER MEDIA MUST ALWAYS BE USED!</b>
*7	Stainless Steel Filter Screen <b>(Optional)</b>	Renewable, sustainable, stainless micro-mesh screen filter media ... direct replacement for filter paper. Can be removed, cleaned and reused. Features silicone edge gasket for proper seal.
8	Filter Pan Cover	Removable cover helps to prevent splash and splatter when draining oil from the fry pot. Can help keep inside of cabinet & floor cleaner.

\* Not included, Optional Item

3.4 Basket & Elevator Assembly



Due to continuing improvements and product enhancements, illustrations might differ slightly from actual unit.



## 3.4 Basket & Elevator Assembly

Item	Description	Function
1	Pot/Basket Cover	Covers fry pot while product is cooking. When used as intended, prevents hot cooking oil from splashing or splattering from pot.
2	Basket Carrier	Attaches the fry basket to basket lift shaft ... holds it in the proper position for lowering, cooking and raising.
3	Basket	Contains product during cooking. Constructed from electro-polished stainless steel woven wire.
4	Basket Lift Assembly	Automatically lowers basket into oil for cooking and lifts it from oil at the end of the cooking cycle. <b>Located inside Cabinet.</b>



3.5 Ventless Hood (VH Model Only)





## 3.5 Ventless Hood (VH Model Only)

Item	Description	Function
1	Filter Access Cover	Provides access to the filter chamber and plenum area ... EAC cell & charcoal filter. The cover must be in place and latched before the fryer will power up.
2	Charcoal Filter	<b>Helps</b> to control cooking aromas in the exhausted air. Filter must typically be replaced monthly. <b>NEVER attempt to clean the charcoal filter ... it is NOT renewable.</b> It is advisable to keep a spare filter on hand (Giles #30248) for quick exchange when needed! <b>NOTE: No filter will completely eliminate aroma from the air.</b>
3	EAC Collector Cell	<i>Electrostatic Air Cleaner</i> removes grease vapors and smoke generated while cooking. The cell is completely renewable and <b><u>should be cleaned daily to maintain peak performance.</u></b> <b>Appliance power must be turned OFF before removing the cell for cleaning.</b> 
4	Baffle Filter	The first stage of the air cleaning system. It is easily removed for daily cleaning. <b>DO NOT remove the baffle filter while the fryer is operating. Doing so exposes electrically charged parts and can lead to electrical shock.</b> 
5	Grease Drip Cup	Collects grease condensate generated by the baffle filter. This cup should be checked & cleaned daily, or as needed.
6	Grease Drip Cup Safety Pin	Secures the Grease Drip Cup, preventing it from unintentionally falling from the holding bracket.
7	Diverter Exhaust Stack	Located atop the hood fan discharge outlet. Diverts exhaust air horizontally to the sides and rear. Allows for [0"] clearance requirement between the ceiling and top of the diverter. It is advisable to allow space for easier moving the appliance when needed.
8	Basket Cover Hanger	Provides a convenient place to hang the basket cover when loading, unloading, or stirring product. One is located on either side of the hood.

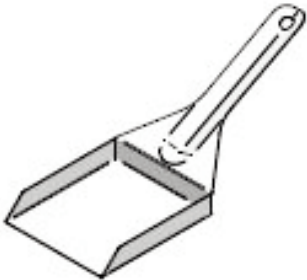
**3.6 Accessories (Included)**

Part	Description / Part Number	Function
	<p>Kettle Drain Brush P/N <a href="#">71025</a></p>	<p>Use for cleaning the fry pot drain in the event of clogging.</p>
	<p>Stirring Utensil P/N <a href="#">77775</a></p>	<p>Use for stirring hot oil and to agitate product while cooking to prevent sticking.</p>
	<p>Pot / Utility Brush P/N <a href="#">71100</a></p>	<p>Use for cleaning fry pot and heating elements &amp; other general cleaning.</p>
	<p>Crumb Shovel P/N <a href="#">30059</a></p>	<p>Use to remove sediment from the surface of the filter media in the filter pan after a filtering cycle.</p>

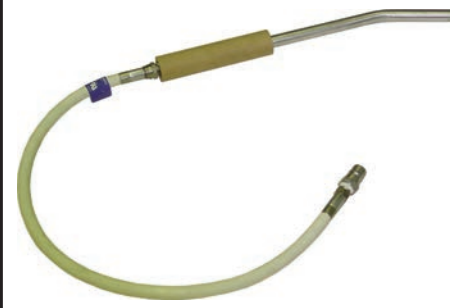

## 3.6 Accessories (Included)

Part	Description / Part Number	Function
	<p>L-Shaped Brush P/N <a href="#">73233</a></p>	<p>Use for cleaning between heating elements and the space between the pot wall and the elements.</p>
	<p>Waste Oil Discharge Hose P/N <a href="#">33667</a></p>	<p>Use for removing waste cooking oil from fryer.</p> <p><b>NOTE: NOT to be used to wash down fry pot.</b></p>
	<p><b>(1) Sample Can</b> Foaming Crystal Cleaner/Degreaser P/N <a href="#">41510</a> <b>12-count Case</b> NSF approved</p>	<p>Spray on foaming degreaser for simple and effective cleaning the EAC collector cell.</p> <p><b>This is GILES recommended cleaner.</b> It is readily available through <i>Giles</i> dealers or on-line distributors, as well as many nationwide retail outlets.</p>

**3.7 Accessories (Not Included, Purchased Separately)**

Part	Description / Part Number	Function
	<p>Filter Paper P/N <a href="#">60810</a></p>	<p>Paper filter media for the filter pan.</p>
	<p>Filter Powder P/N <a href="#">72004</a></p>	<p>Filter aid to help clean the cooking oil during the filtering cycle. Removes soluble impurities from oil.</p>
	<p>Giles Fryer Boil-Out P/N <a href="#">72003</a> Case of (24) pre-measured <b>6-oz</b> Packets</p>	<p>Fryer cleaner/degreaser ... add to water for a fryer boil-out cleaning procedure. Typical fryer requires (2) packets. Can be used as an overnight fryer cleaning soak. Also suitable for cleaning tile &amp; concrete floors</p>

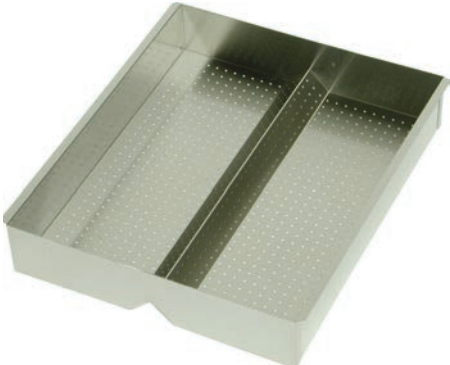
## 3.7 Accessories (Not Included, Purchased Separately)

Part	Description / Part Number	Function
	<p>Filter Pan Crumb Screen P/N <a href="#">39246</a></p>	<p>Catches larger crumbs and cooking residue as oil drains into the filter pan for filtering. Helps reduce potential of filter system clogging.</p>
	<p>Stainless Steel Renewable Filter Screen P/N <a href="#">41014</a></p>	<p>Reusable replacement for filter paper. Durable stainless steel media can be cleaned and reused many times. Provides same filtering performance as paper media.</p>
	<p>Giles Oil Caddy P/N <a href="#">79187</a></p>	<p>Portable, waste oil disposal container with capacity for 80 lbs of waste cooking oil. Manually operated pump, no electrical connection needed.</p> <p><b>Note: For use with filtered, warm oil only. No crumbs or debris.</b></p>



**Notes:**

## 4. Fryer Operation

This section describes the various procedures necessary for operating and maintaining *Giles Models GEF & GEF-VH Electric Fryers*.

### **⚠ DANGER**

- Turn OFF fryer **POWER** switch and disconnect supply power at main electrical panel prior to cleaning or performing maintenance.
- **DO NOT** wash down the appliance with water from a spray hose, or other pressure-type washing equipment.
- Failure to comply with **DANGER** notices will result in serious injury, even death, damage to equipment or property and void the factory warranty

### **⚠ WARNING**

- **DO NOT** use or store flammable liquids, or materials that produce flammable vapors, in the vicinity of this or any other appliance!
- **DO NOT (or ALLOW OTHERS to) stand or step onto the top of the fryer for any reason.** Very serious injury can result from slips and falls, or from bodily contact with extremely **HOT** cooking oil in the cooking vat (**excess of 330°F/166°C**). Removable covers often placed over cooking vats and pots are **NOT designed to, and WILL NOT, support the weight of a person.** 
- Failure to comply with **WARNING** notices could result in serious injury, even death; damage to equipment and/or property and will void the factory warranty.

### **⚠ CAUTION**

- Be sure the fryer is positioned in a stable, safe location with front caster wheel brakes locked.
- Exercise caution when operating and cleaning. **To avoid personal injury, wear thermal protection (gloves or mitts) while tending the appliance.** Certain parts of fryer can become very **HOT** during operation; temperatures inside the cabinet may exceed **150°F/65.5°C and cooking oil temperature is in excess of 330°F/166°C.**
- This appliance is for professional use only and is to be operated by qualified personnel. It is not intended for use by persons (including children) with reduced physical, sensory, or mental capabilities, or those lacking experience and knowledge, unless they have been given adequate instruction and/or supervision concerning its operation by a person responsible for their safety.

4.1 Computer Cooking Controller

This section explains the functions, features, and operational procedures for the *single-timer Computer Controller*. The controller has been designed to be user-friendly and many operational instructions and prompts will be shown on the *upper display* (blue graphic) to help guide you through each process.



4.1.1 Keys and Functions



**Numeric Keypad:** Use to enter fryer settings and program & edit *Menu Item cooking presets*.

**Arrow Keys:** The [2] • [4] • [6] • [8] keys are used as directional keys for manually operating the basket Lifts, scrolling through lists, moving the cursor, operating the basket lift, etc: [2]=UP, [8]=DOWN, [4]=LEFT, [6]=RIGHT. When active as *arrow keys*, each will be illuminated.

**[START]:** A function key is used for various operations ... starting cook cycles, selecting items, saving settings, etc.

**[CLEAR]:** A function key used for canceling cook cycles, exiting certain functions, etc.

### 4.1.1 Keys and Functions - continued



**MENU Key:** Action key which is pressed in combination with other keys to access programmed menu item presets. Up to fifty (50) different programmable presets can be created & stored.



**EDIT Key:** Action key which is pressed in combination with other keys to enter *edit mode* for changing or entering new *Menu Item preset* cook settings.



**TEMP Key:** Press this key to set a cooking oil temperature setpoint. When fryer is in **READY** state, Pressing key twice (2x) will display *actual oil temperature* on the *lower display* for approximately **20 secs**. **NOTE:** During **PREHEAT**, real-time actual temperature is displayed.



**CLOCK Key:** Press this key to begin manually setting a cooking time (mm:ss).



While in **PREHEAT** state, press this key to start the **BOIL-OUT** program. Temp setpoint and time will change to the **BOIL TEMP** and **BOIL OUT TIME** specified in *User Settings, Section 4.1.7, Edit User Settings*. **Defaults = 200°F & 30 mins**.



Press this key to enter **COOL** mode. An energy-saving feature, places fryer at a lower temperature during inactive periods. Temp setpoint will change to the **COOL TEMP** specified in *User Settings, Section 4.1.7, Edit User Settings*. **Default = 275°F**.



**ALARM Key:** Pressing this key silences the controller alarm and acknowledges certain status messages.



**BASKET Key:** Enables arrow keys **[2]-UP** & **[8]-DOWN** for manually operating the automatic basket lift. Key is **disabled** during **PREHEAT** mode to prevent lowering of product into oil that is not yet at the proper cooking temperature.



**Upper OLED Display (blue graphic):** Displays cook settings, fryer status information, operational instruction prompts, alarm/error messages, etc..



**Lower 7-Segment Display (red graphic):** Displays status information, cook cycle time countdown, temperature, error codes, etc.

**[HEAT]** indicator illuminates when controller is calling for the heating elements to energize.

**4.1.2 Controller - General Overview**

The following is only general information ... detailed procedures and instructions are covered in subsequent sections. During operation, certain instructions and prompts are shown on the *upper controller display* to help guide you through processes. Additionally, some controller keys and indicator lights will illuminate as a further aid.

- **POWER UP:**  
 When **POWER** switch is placed in the **[ON]** position, controller will power up and sound an alarm. The message **“POWER FAILURE [PRESS START TO PREHEAT]”** is shown on the *upper display*. ***This is normal***, intended to prevent the fryer from beginning to heat after power interruptions without an operator present. Pressing the **[START]** key silences the alarm and places fryer into **PREHEAT** mode. If the control panel **SELECTOR** switch is in the **[COOK]** position, and controller temp setpoint is higher than current actual oil temperature, heating elements will turn ON and cooking oil will begin heating. ***DO NOT place the SELECTOR switch in [COOK] position unless vat is filled to the FULL level with cooking oil or water.***
  
- **PREHEAT:**  
 While oil heats during **PREHEAT**, the real-time actual oil temperature is displayed on the *lower display*. When oil reaches the programmed setpoint, an alarm will sound and *upper display* shows message **“ALARM - STIR OIL”**. Vigorously stir the cooking oil and press the **[ALARM]** key. Typically, oil temp drops when stirred ... controller enters a *10 second delay* and if temperature drops below setpoint during this time, **PREHEAT** continues until temp returns to setpoint. ***This process helps to ensure more consistent temperature throughout the total volume of oil, leading to better cooking performance.*** Upon reaching setpoint again, alarm sounds and *upper display* shows **“ALARM - SETPOINT REACHED”**. Pressing the **[ALARM]** key, places fryer into **READY** state.
  
- **READY STATE:**  
 Oil is at cooking temperature and fryer is ready to cook. The *lower display* changes to show the current controller temperature setpoint and *upper display* shows the last cook settings used.  
  
 While in **PREHEAT** or **READY** state, fryer settings can be changed ... select a different menu item preset, see **Section 4.1.4.2, Selecting a Menu Preset** to change cook temp, time and food name - **OR** - manually enter different settings, see **Section 4.1.3, Setting a Manual Temperature & Cook Time**.  
  
**NOTE: If PASSCODE ENABLE is set to [ON], you cannot manually enter a cook time or temp without the proper password. This security feature provides management control over cooking procedures.**
  
- **START:**  
 Current cook settings (*preset or manual*), are shown on the *upper display*. To start the displayed cooking cycle press the **[START]** key. When started, cooking time count down begins, shown on the *lower display*.



## 4.1.3 Manually Entering a Cook Time & Cooking Temperature

The following explains the process for manually entering cooking time and temperature.

**CAUTION** Before setting temperature, be sure the SELECTOR switch is in the [OFF] position and that pot is filled with cooking oil.

**NOTE:** After manually entering the *cook time and/or temperature*, the upper display shows the label [MANUAL] instead of a Menu Item name.



**IMPORTANT!**

If the **PASSCODE** feature is enabled, *time / temperature* settings **cannot** be manually entered without inputting the required password. You can only choose from the list of programmed *Menu Item Presets*, see **Section 4.1.4, Working with Menus**.

**Set Cook Time: (mm:ss)**

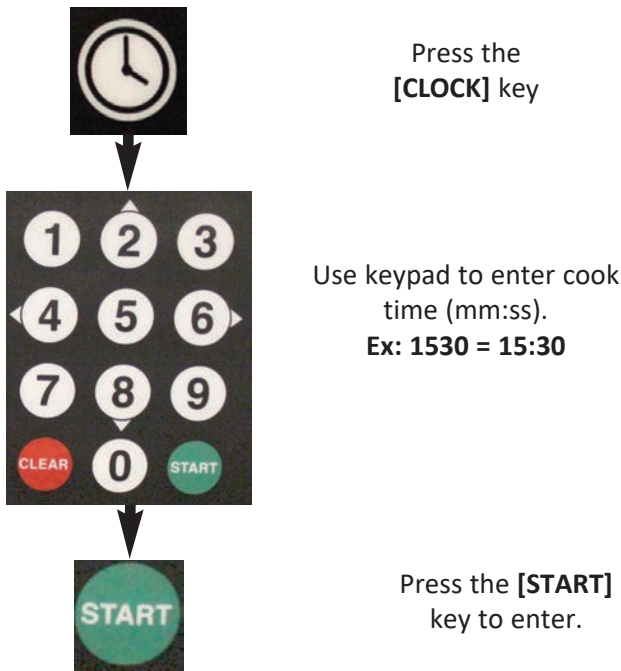

**Set Cook Temperature: (°F)**

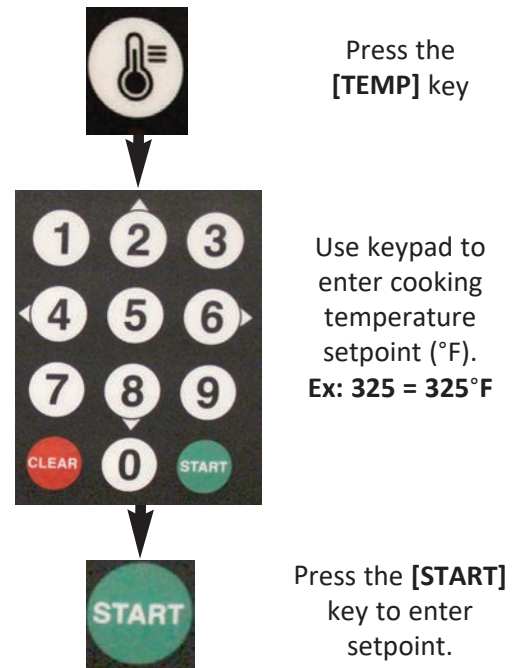

**NOTE:** Pressing [TEMP] key twice (2x) will display actual oil temperature on lower display for 20 seconds

**WARNING** DO NOT place SELECTOR switch in the [COOK] position unless vat is filled to the [FULL] level with cooking oil or water, and you are ready to start heating.

- If actual oil temperature is lower than the entered setpoint, controller enters **PREHEAT** (small red [HEAT] indicator light on controller turns ON). Before oil will actually begin heating, the **SELECTOR switch on the control panel must be placed in the [COOK] position**. The amber **HEAT** indicator light on the control panel will turn ON and heating begins.
- If oil temperature is already equal to or greater than the entered setpoint, alarm sounds and the message **"STIR OIL"** is displayed. Press the [ALARM] key and stir oil. If oil remains at setpoint for 10 seconds, alarm sounds again and the message **"SETPOINT REACHED"** is displayed. Press [ALARM] key and controller enters **READY** state; fryer is ready for cooking. If temp drops while stirring, fryer remains in **PREHEAT** until temp is again reached.

While heating, **real-time actual oil temperature** is shown on the lower display. After setpoint is reached, display will change to show the **temperature setpoint**. Press [TEMP] key twice to display actual oil temp.

**4.1.4 Working with Menu Item Presets**

Fifty (50) different *Menu Item Preset* cook settings can be stored in the controller, each includes:

- **Menu #** - Sequential ID number
- **Menu Name** - Name of the food product assigned to the preset.
- **Cooking Time** - Cook time setting for the item.
- **Cooking Temperature** - Cooking oil temperature setting for the item.
- **STIR OVERRIDE** - Overrides the global controller **STIR ALARM** parameter set in *User Settings* for this menu item only. **Factory default = [NORMAL]**.
- **FISH FILTER** - To prevent potential flavor transfer, establishments cooking seafood can force filtering of cooking oil after only **one (1) batch** of product is cooked. This setting overrides the global **FORCE FILTER** parameter specified in *User Settings*. **Factory default = [OFF]**. A **SNOOZE** feature can be selected which will allow **two (2) batches** to be cooked before forced filtering.

All *Menu Presets* are factory-programmed with default settings. The first ten (10) are set for some popular typical menu items (*names & settings shown in table below*). The general settings as shown on the last line are stored in all others. As needed, you can edit any of these settings to customize for your specific applications and menus.

Explanation for working with *Menu Item Presets* are presented in the following sections.

MENU NO.	MENU NAME	TEMP (F°)	TIME (MM:SS)	STIR OVERRIDE	FISH FILTER
1	BONE-IN-CHICKEN	335°	13:00	NORMAL	OFF
2	TENDERS	335°	7:00	NORMAL	OFF
3	WEDGES	335°	6:00	NORMAL	OFF
4	BONE-IN-WINGS	335°	8:00	NORMAL	OFF
5	BONELESS WINGS	335°	7:00	NORMAL	OFF
6	POPCORN CHICKEN	335°	3:00	NORMAL	OFF
7	LIVERS	335°	4:00	NORMAL	OFF
8	CORNDOGS	335°	10:00	NORMAL	OFF
9	CHEESE STICKS	335°	3:00	NORMAL	OFF
10	FISH	335°	3:00	NORMAL	OFF
<b>11 thru 50</b>	<b>MENU XX</b>	<b>335°</b>	<b>2:00</b>	<b>NORMAL</b>	<b>OFF</b>

**NOTE:**

Some customers have arranged for purchased fryers to be preloaded with their specific Menu Set. If that is the case, the first 10 menu items will be different than those shown above.

## 4.1.4.1 Editing a Menu Preset

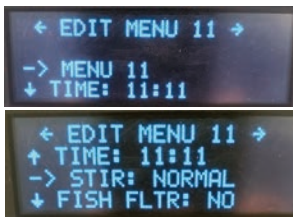
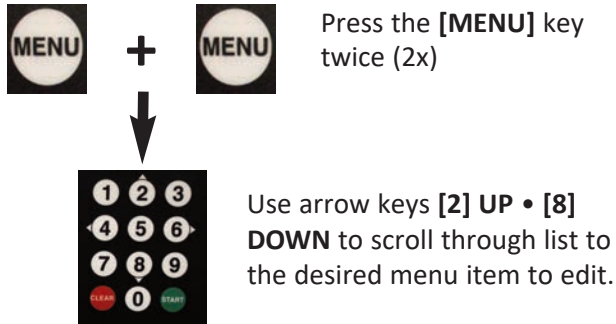

Use arrow keys [2 / 8] to move the cursor [→←] until it points to the preset item you wish to edit:

- NAME
- TIME
- TEMP
- STIR
- FISH FILTER

Press [START] to select if editing **NAME**, **TIME** or **TEMP** ... when pointing to **STIR** or **FISH**, pressing [START] only toggles between setting choices.

Press the [START] key to begin edit



Edit NAME: Two methods available

### Method 1

*Enter NAME letter by letter*

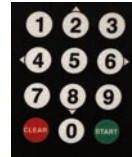

Choose **NAME** setting as described at the left. A flashing cursor will appear at the first letter of the current name. Use arrow keys [2 / 8] to scroll thru alphabet ... the character at cursor changes ... stop on the desired letter. Press right arrow key [6>] to move cursor to next character in the **name** ... repeat until item name is complete.

When finished editing, press [START] to save

- OR -

Press [CLEAR] to **Cancel & Exit** without saving



Use left arrow key [←4] to backspace and erase errors.

### Method 2

*Select a NAME from catalog of programmed names.*

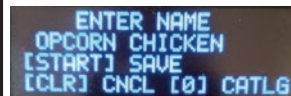

Choose **NAME** setting as described. Cursor appears at first letter. Press [0] key to open a **catalog** of **programmed names** ... use arrow keys [2 / 8] to scroll through list. Stop at desired name & press [START] to copy the selected name to the item being edited & previous display returns.



When finished, press [START] to save - OR - Press [CLEAR] to **Cancel & Exit** without saving - OR - Press [0] to re-open the **name catalog**.

4.1.4.1 Editing a Menu Item Preset - continued

Edit COOKING TIME:

Scroll to and select TIME for editing as shown previously.



Current time setting is displayed. Use numeric keypad to enter the new TIME (mm:ss)



NOTE: All digits must be entered, e.g. 1000 = 10:00, 105 = 1:05 Press the [CLEAR] key to backspace and erase errors.



After entering new value, press [START] to save - OR - Press CLEAR to exit without saving



Edit COOKING TEMPERATURE:

Scroll to and select TEMP for editing as shown previously.



Current temp setting is displayed. Use keypad to enter new cooking TEMP setpoint (°F). 335 = 335°F Max = 350°F



Press the [CLEAR] key to backspace and erase errors.

NOTE: Temperature unit can be changed to [°C] in User Settings, see Section 4.1.7



After entering new value, press [START] to save - OR - Press CLEAR to exit without saving



Continued on Next Page

### 4.1.4.1 Editing a Menu Item Preset - continued

#### Edit STIR OVERRIDE Setting:

---

Regardless of the global **STIR ALARM** setting in *user settings* (Section 4.1.7), you may want to have a food item stirred or not stirred during the cook cycle. **STIR OVERRIDE** overrides the global setting for the specific item.

Available settings = **[NORMAL]** • **[SKIP]** • **[FORCE]**.

**[NORMAL]** = the alarm is issued as specified.

**[SKIP]** = the alarm is **NOT** issued for the item, regardless of global setting.

**[FORCE]** = the alarm is **ALWAYS** issued for the item, regardless of global setting.

Factory-default = **[NORMAL]**

To edit setting, scroll to and select as described previously ... **[→]** points to **[STIR]**



Press the **[START]** key to toggle between the available options, stop on desired setting.

#### Edit FISH FILTER Setting:

---

To minimize potential for flavor transfer, establishments that cook seafood along with other proteins, may wish to force operators to filter the oil after cooking **only one (1) batch** of a seafood product. When **FISH FILTER** is set to **[ON]**, the unit will enter forced **FILTER MODE** after completing one load the specific item. If **FORCE FILTER SNOOZE** is set to **[ON]** in *user settings* (Section 4.1.7), an additional load may be cooked before filtering is forced. When **FORCE FILTER** = **[OFF]** only a filter warning message is displayed on the *upper controller screen* ... when **FORCE FILTER** = **[ON]**, the fryer is locked out until the filter cycle is completed.

To edit setting, scroll to and select as described previously ... **[→]** points to **[FISH FLTR]**



Press the **[START]** key to toggle between the selections and stop on desired choice.

4.1.4.2 Selecting a Menu Preset for Cooking

**CAUTION** Before selecting a menu preset, be sure that *SELECTOR switch* on control panel is in the [OFF] position and that pot is filled with cooking oil.

A. Direct Entry Method - desired *Menu* is known.

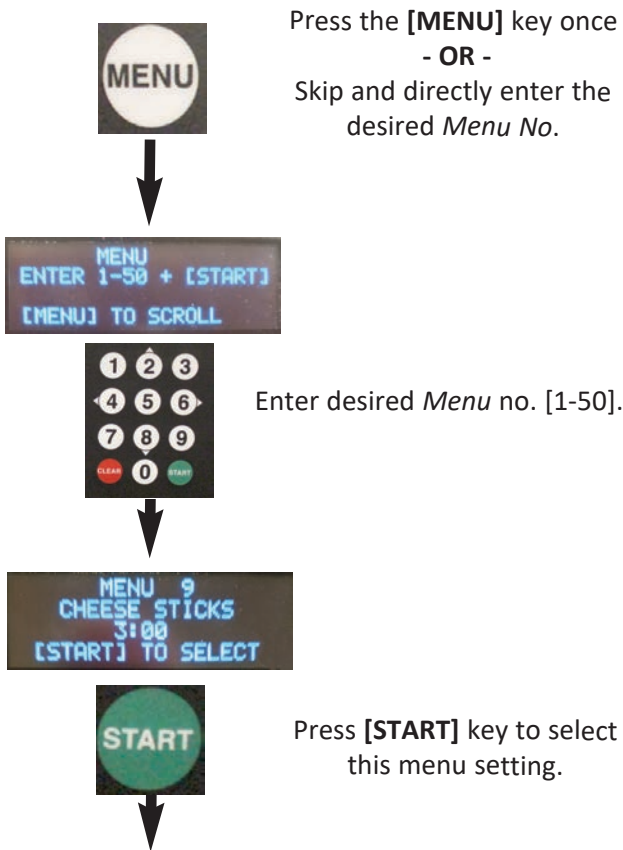

B. Scroll Method - Scroll through list of *Menu Presets*. Settings are shown on the *upper display*.

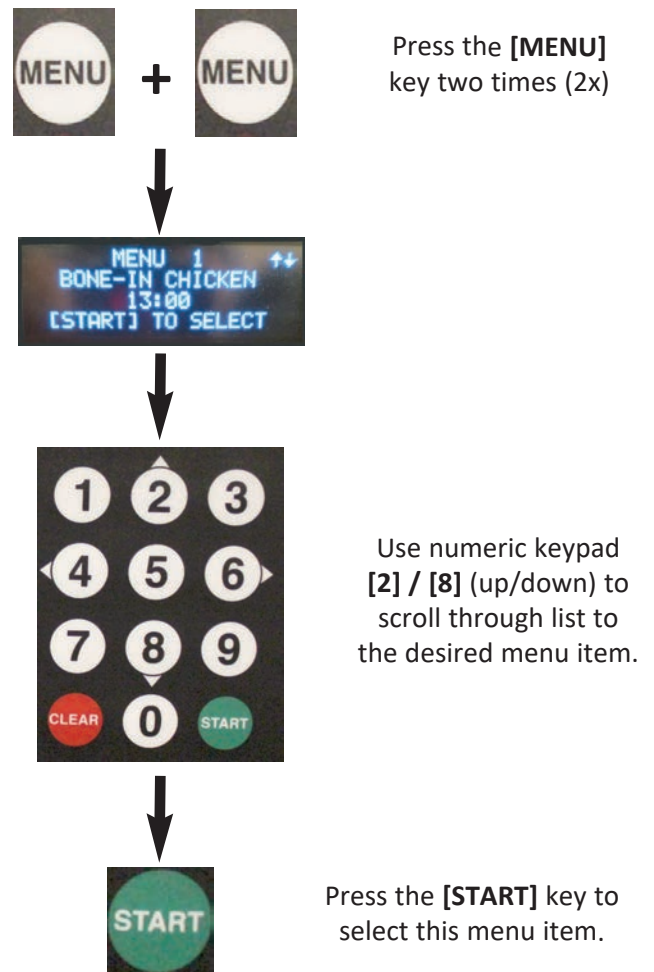

Selected menu Item information is shown on the *upper display*.  
After selecting, place control panel *SELECTOR switch* in [COOK] position.

If actual oil temperature is lower than the temperature setting of the selected preset and the *SELECTOR switch* is in the [COOK] position, heating elements turn **ON** and oil begins heating. If actual temperature happens to be higher than controller setpoint, fryer will immediately enter **READY** state and cooking may begin.

**NOTE:**  
*Basket lift is disabled while fryer is in PREHEAT mode. Lift is enabled when setpoint is reached and fryer enters READY state.*

### 4.1.5 Cooking Cycle - General Overview



**COOKING TEMPERATURE • MENU NAME • COOK TIME • STIR OVERRIDE • FISH FILTER** settings are shown on the *upper display*. **READY** notification indicates that cooking oil is at the set temperature and fryer is ready for cooking.



When in **READY** state the **TEMP** setpoint will be displayed on the *lower display*.

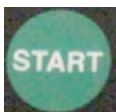

To start the cook cycle, press the **[START]** key once. Basket will automatically lower into the cooking oil and cook **TIME** will begin counting down, shown on the *lower display*.

**STIR ALARM:** When active, an alarm tone is sounded at a set specific time during the cook cycle, signaling the operator to stir the cooking product. Stirring helps to promote more even cooking and prevent pieces from sticking. To function, the feature must be enabled in *User Settings, Section 4.1.7* and the parameters set. **[STIR ALARM %]** = amount of elapsed time before the alarm sounds. For example, if **[STIR ALARM %]** = **60**, then during a **10 min.** cook cycle, the alarm will sound after **6 mins.** of time have elapsed.

**Factory-set default:** **[STIR ALARM ENABLE]** = **ON** and **[STIR ALARM %]** = **62**.

A menu item **STIR OVERRIDE** setting can override the **[STIR ALARM ENABLE]** setting, see *Section 4.1.4.1*.

When cooking cycle time is complete, an alarm will sound and the message **“DONE COOKING”** is displayed. The cook basket is automatically raised from the pot. Pressing the **[ALARM]** key silences the alarm and fryer returns to **READY** state, awaiting the next load of product.



x 2

To cancel a running cook cycle press the **[CLEAR]** key once, then press it again to cancel **-OR-** press **[4]** to continue the cook cycle.

### 4.1.6 Other Controller Features

#### 4.1.6.1 Manually Operating the Basket Lift



- OR -



Press the **[BASKET]** key once

Use **[2] UP** & **[8] DOWN** keys to raise or lower the basket lift

**NOTE:**

- Manual lift operation is disabled while the controller is in **PREHEAT** state. This is a safeguard against attempting to cook product in oil that is not yet at the proper cooking temperature.
- Once activated, the lift cannot be manually actuated again for approximately **20 secs.** or until the red indicator over the **[BASKET]** key turns OFF.

**4.1.6.2 COOL Mode**



**COOL mode** is an energy-saving feature that lowers the oil temperature setpoint value, placing fryer into an idle standby state during periods of inactivity.

Press the [COOL] key once to enter **COOL** mode. Temperature setpoint changes to the **COOL TEMP** setting specified in *user settings*, see *Section 4.1.7*.  
**Factory-set default = 275°F ... setting range is 200°F - 350°F.**

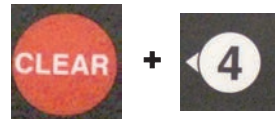

To exit **COOL mode** press the [CLEAR] key, then press [<4] to exit  
 - OR -

Press [CLEAR] again to continue with **COOL** mode.

Upon exit, the temperature setpoint will return to the previous active value and fryer will enter **PREHEAT** until temperature is reached.

**4.1.6.3 AUTO-COOL**

When the **AUTO-COOL** feature is turned [ON], fryer automatically enters **COOL mode** if no cook cycles are started within the amount of time specified by the [AUTOCOOL TIME] setting in *user settings*, see *Section 4.1.7, Edit User Settings*.

**Factory-set default: [AUTOCOOL] = OFF ... [AUTOCOOL TIME] = 30 ... setting range is 1 to 510 mins.**

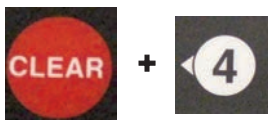

Exit **AUTO-COOL** same as **COOL** ... press the [CLEAR] key, then press [<4] to exit  
 - OR -

Press [CLEAR] again to continue **COOL** mode.

Upon exit, the temperature setpoint will return to the previous active value and fryer will enter **PREHEAT** mode until temperature is reached. The **STIR OIL** alarm is issued when setpoint is reached, as described in *Section 4.1.5*

**4.1.6.4 BOIL OUT Program**



Pressing the [BOIL] key while controller is in **PREHEAT** begins the **BOIL OUT** program. Temperature and time change to the **BOIL TEMP** and **BOIL OUT TIME**, respectively, as specified in *user settings*, see *Section 5.1.7*.

**Factory-Default Setting:**

**BOIL TEMP = 200°F ... setting range is 185° to 208°F.**

**BOIL OUT TIME = 30 minutes ... setting range is 1 to 45 mins.**

**IMPORTANT!**  
 After **BOIL OUT** program is complete, the controller automatically resets the temperature setpoint to 50°F. It must be reset to a proper cooking temperature, either manually or by choosing a menu preset, before the fryer will heat cooking oil for normal operation.

*Fryer must be properly drained, rinsed and prepared for cooking after a Boil Out cycle. See Section 5, Cleaning.*

### 4.1.7 User Settings

To access the *User Settings* menu for editing ...

Press  
[TIME] key



Enter on  
keypad

9 9 9 9

Press  
[START] key

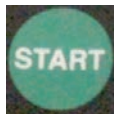

The table below details available *User Settings* and factory-set *Defaults*.

Keypad [4] / [6] (left/right) will scroll through the list of *user settings* ... current setting value will be shown on the *upper controller display*.



- Press the [EDIT] key, when setting is displayed.
- Use keys [2] / [8] (up/down) to change the setting value. Press [EDIT] key again to **SAVE** choice.



To exit *User Settings* menu, press the [CLEAR] key.

**NOTE:**

A message **“TOO LOW”** or **“TOO HIGH”** is displayed if an entered value is outside of the allowable range and will cause a controller error.

NAME	DESCRIPTION	RANGE	DEFAULT
TEMP SCALE	Temperature unit of measure	°F or °C	°F
FORCE FILTER	When <b>ON</b> , forces operators to filter oil after the number of cook cycles set in <b>FILTER COUNT</b> are completed ... locks-out fryer until filtering complete.	ON - OFF	<b>ON</b>
FORCE FILTER SNOOZE	When <b>ON</b> , allows (1) additional cook cycle after <b>FILTER COUNT</b> is exceeded, when <b>FORCE FILTER</b> is <b>ON</b> .	ON -OFF	<b>OFF</b>
FILTER COUNT	Number of cook cycles before filtering is required.	1 to 20	<b>4</b>
GUARD BAND	Cooking not allowed if oil temperature is outside of the setpoint by amount of guard band	1 to 990	<b>900</b>
MAX SETPOINT	Maximum oil setpoint allowed by controller.	32°F to 375°F	<b>350°</b>
AUTOCOOL	After a specified amount of time, unit will enter <b>COOL</b> mode.	ON - OFF	<b>OFF</b>
AUTOCOOL TIME (MINUTES)	When <b>AUTOCOOL</b> is <b>ON</b> , fryer automatically enters <b>COOL</b> mode after unit is idle for this amount of time.	1 to 510 minutes	<b>30</b>
AUDIBLE ALARM (SECONDS)	Duration of the audible alarm in seconds, automatically silences after this amount of time..	5 to 120 seconds	<b>10</b>
COOL TEMP	Temperature setting for <b>COOL</b> mode	200°F to 350°F	<b>275°F</b>
BOIL TEMP	Temperature setting for the <b>BOIL OUT</b> cycle	185°F to 208°F	<b>200°F</b>
FILTER RESET	A temperature that resets fryer to exit <b>FILTER MODE</b> .	200°F to 325°F	<b>290°F</b>
BOIL OUT TIME	Time (in minutes) for the <b>BOIL OUT</b> cleaning cycle	1 to 45 minutes	<b>30</b>
STIR ALARM ENABLE	If <b>ON</b> , sounds the <b>STIR ALARM</b> at specified % of cook cycle completion.	ON - OFF	<b>ON</b>
STIR ALARM %	When <b>STIR ALARM</b> is <b>ON</b> , the alarm sounds after this percent [%] of cooking cycle has elapsed.	10% to 90%	<b>62%</b>
KEY BEEP ENABLE	If <b>ON</b> , an audible sound is generated with each keystroke.	ON - OFF	<b>OFF</b>

Continued on Next Page

4.1.7 User Settings - continued

NAME	DESCRIPTION	RANGE	DEFAULT
LANGUAGE	Sets the controller language	English-Spanish-French	English
[0] KEY EXTRA TIME	If enabled, operator can add extra time to cook cycle ( <i>after or during the cycle</i> ) by pressing [0] + the number of minutes to add.	ON - OFF	OFF

4.1.8 PASSWORD Protection

It is possible to add **PASSWORD** protection for certain controller settings. This feature is a **FACTORY SETTING** that is typically **DISABLED**. If **PASSCODE ENABLE** is set to **[ON]**, you are prompted to enter a password before performing many controller operations.

If you desire to have password protection enabled, or have questions concerning this feature, call **Giles Technical Services at 800.554.4537** to request the passcode and instructions as to how to enable the feature.

4.1.9 Start-up Procedure

4.1.9.1 Non-Ventless Fryer (GEF)

1. Be sure that the **SELECTOR** switch ① is in the center **[OFF]** position.
2. Place **POWER** switch ② in the **[ON]** position and green **POWER** light ③ will illuminate.

The computer controller powers-up, performs a memory check and then sounds an alarm. The message **"POWER FAILURE [PRESS START TO PREHEAT]"** is shown on the upper display ④. **This is normal** and occurs every time power is turned OFF and back ON. It is to prevent fryer from beginning to heat after a power interruption until it is attended by an operator. Pressing the **[START]** key silences the alarm and places fryer into **PREHEAT** mode. Fryer settings shown on the upper display will be those last used. The red **HEAT** indicator on controller indicates that it is calling for heat, but until the **SELECTOR** switch is placed in the **[COOK]** position, the heating elements will not be energized.

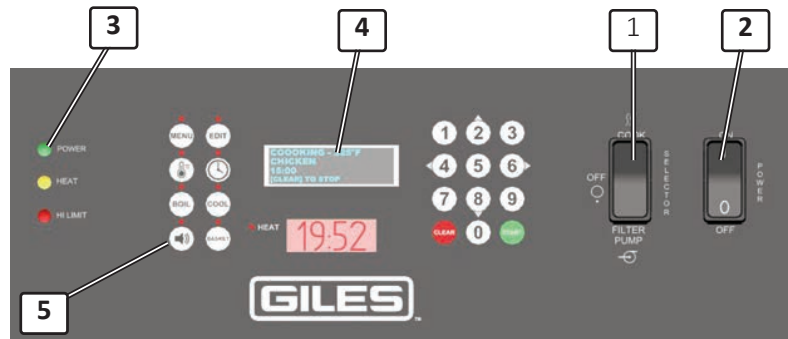

**⚠ DO NOT** place switch in **[COOK]** position unless pot is filled with cooking oil or water, see **Section 4.2, Cooking Procedures**.

**NOTE:** Pressing the **[ALARM]** key ⑤ silences alarm tones ... alarm will also silence automatically after a few seconds.

### 4.1.9.2 Ventless Fryer (GEF-VH)

Be certain that all hood filters are properly installed and that the *Access Cover* is in place and securely latched before using the appliance.



**NOTE:**

*The appliance will **NOT** power-up if the access cover is missing or ajar. The sides of the cover must seat flush against the hood front and the pin on the right-hand edge must engage the interlock switch inside the hood wall.*

1. Ensure that the **SELECTOR** switch ① is in the center **[OFF]** position.
2. Place **POWER** switch ② in the **[ON]** position, green **POWER** light ③ will illuminate and the hood fan will start. The computer controller will powers-up, performs a memory check and then sounds an alarm tone. The message **“POWER FAILURE [PRESS START TO PREHEAT]”** is shown on the **Upper Display** ④. ***This is normal*** and occurs every time controller is turned OFF and back ON. It is to prevent fryer from beginning to heat after a power interruption until it is attended by an operator. Pressing the **[START]** key silences the alarm and places fryer into **PREHEAT** mode. Fryer settings shown on the *upper display* are those last used. The red **HEAT** indicator on controller indicates that it is calling for heat, but until the **SELECTOR** switch is placed in the **[COOK]** position, heating elements will not be energized.



**DO NOT** place **SELECTOR** switch in **[COOK]** position unless pot is filled with cooking oil or water, see **Section 4.2, Cooking Procedures.**

3. The hood fan will come to full speed and the E.A.C. status **[ON]** light ⑤ will turn ON. If the **[WASH]** or **[CHECK]** status lights also turns ON, there could be a problem with the *E.A.C. Air Cleaning system.* **See Section 7, Troubleshooting.**
4. If an alarm sounds when hood starts and controller displays error messages, consult **Section 4.1.10, Controller Errors & Alarms** and attempt to resolve the issue.

**NOTE:**

Pressing the **[ALARM]** key ⑥ silences alarm tone. Tone also silences automatically after a few seconds.

4.1.10 Controller Errors & Alarms

Conditions that can cause unsafe operation or result in damage to the unit (*open valves, low oil level, high temp, hood problems, etc.*) will halt fryer operation, activate an alarm tone and display error codes/messages.

Error codes are shown on the **7-Segment Display**; error messages and prompts are shown on the **OLED Display**.

Generally, heating elements are disabled until error conditions have been corrected. Pressing the **[ALARM]** key silences the alarm, but does not clear an error. Error codes are shown in the Table below and further details are discussed in the following section.



ERROR CODE	DESCRIPTION ( <i>upper display</i> )	PROBLEM
OPEN	DRAIN IS OPEN	Drain valve is open, or not completely closed. If down, basket will be raised from pot. Closing drain should clear error.
----	CHECK OIL LEVEL, ENSURE VAT IS FULL, IF FULL THEN PRESS [START]	This is a notification to confirm oil level that is displayed after closing drain has cleared the <b>OPEN</b> drain error.
ER03	LOW OIL LEVEL – ENSURE VAT IS FULL (Element/Add Level Differential Warning)	The oil level is below the <b>[ADD]</b> mark. Add oil to the <b>[FULL]</b> the mark & stir. Error will remain in effect until temp differential at the probe is resolved.
ER06	LOW OIL LEVEL – ENSURE VAT IS FULL – PRESS [START] (Post ER03 Warning)	After an <b>ER03</b> is cleared, this notification is displayed until user presses <b>[START]</b> to confirm oil level.
ER07	MAX ELEMENT TEMP – PRESS [START] (Post Warning)	Error is displayed after <b>MAX</b> element temperature ( <b>ER19</b> ) has occurred and element has cooled below <b>MAX</b> temperature, .
ER13	OIL PROBE Error	Problem with the <i>variable oil temp probe</i> . <b>Service call generally required.</b>
ER15	ELEMENT PROBE Error	Problem with <i>element temp probe</i> , attached directly to heating element. <b>Service call generally required.</b>
ER17	ADD LEVEL PROBE Error	Problem with <i>add level probe</i> at pot <b>[ADD]</b> mark. Fryer without this probe should have <b>ELMT-ADD DIFF ENABLE</b> setting <b>[OFF]</b> in <b>Factory Settings</b> . <b>Probe cannot be bypassed. Service call generally required.</b>
ER19	MAX ELEMENT TEMP Error	The maximum heating element temperature has been exceeded. <b>This is a safety device; NEVER bypass this probe.</b>
ER21	BAFFLE FILTER MISSING	<b>Ventless Fryers (VH) Only ...</b> Baffle Filter is missing, or improperly installed.
ER22	CHARCOAL FILTER MISSING	<b>Ventless Fryers (VH) Only ...</b> Charcoal Filter is missing, or improperly installed.
ER23	FILTER CLOGGED	<b>Ventless Fryers (VH) Only ...</b> airflow through hood is below minimum. Charcoal filter is clogged, or there are other obstructions. Replace filter, remove any obstruction.
ER24	EAC CELL DIRTY	<b>Ventless Fryers (VH) Only ...</b> E.A.C. collector cell is dirty, requires cleaning. This error can also have other causes.

## 4.1.10 Controller Errors & Alarms - continued

ERROR CODE	DESCRIPTION ( <i>Upper Display</i> )	PROBLEM
ER25	GUARD BAND EXCEEDED	Actual oil temperature deviates from setpoint by the guard band amount. Allow oil to cool, or heat, to within range. Factory default is 900°F ... <b>Error should not occur.</b>
ER37	EEPROM Error	An error occurred while saving settings to the EEPROM. <b>Contact Giles Tech Service (800.554.4537).</b>
ER38	Internal ADC Error	The ADC (Analog-to-Digital Converter) chip has failed. MCB1 board must be replaced. <b>Contact Giles Tech Service (800.554.4537).</b>

### 4.1.10.1 Resolving Controller Errors & Alarms

The following is a summary explanation of various controller errors/alarms and some basic steps which can be taken to resolve them and return to normal operation. The inability to resolve an error/alarm by following these steps may indicate a more serious malfunction of a fryer system or component, requiring the attention of a qualified service person.

- DRAIN OPEN (Error Code OPEN)** - If the pot drain valve is open (*even slightly*) while fryer power is ON, an alarm sounds, *lower display* reads “**OPeN**”, and *upper display* reads “**ERROR ALARM - DRAIN IS OPEN**”. If the basket lift is down, it will be raised. Heating elements are disabled as long as the condition exists.

Press the [ALARM] key to silence alarm. Completely close the *drain valve* to clear error. When error is cleared, alarm sounds again and *upper display* reads “**CHECK OIL LEVEL, ENSURE VAT IS FULL, IF FULL THEN PRESS [START]**”. This is a post-error notification alerting user to confirm that cooking oil in the pot is at the [FULL] mark. Add oil if needed, then press the [START] key to return to PREHEAT mode.
- LOW OIL LEVEL (Error Code 03)** - Alarm sounds, *lower display* reads “**Er03**”, and *upper display* reads “**ERROR ALARM - CHECK OIL LEVEL - ENSURE VAT IS FULL**”. Heating elements are disabled until condition is corrected. The temperature differential between a sensor located at the [ADD] mark and one attached to heating element exceeds an acceptable value, indicating low oil level. **Low oil level greatly increases the possibility of fire!** Press [ALARM] key to silence alarm and place SELECTOR switch in [OFF] position. Allow fryer to adequately cool, then add oil to raise level to the [FULL] mark.
- LOW OIL LEVEL Post-error Warning (Error Code 06)** - After Error 03 clears, a warning alarm occurs. *Lower display* reads “**Er06**”, and *upper display* reads “**CHECK OIL LEVEL - ENSURE VAT IS FULL - PRESS [START]**”. This notification alerts user to confirm that cooking oil in the pot is at the [FULL] mark. If oil was added, press [START], otherwise press [ALARM] key to silence tone, add oil, then press [START] key to enter PREHEAT mode.
- MAX. ELEMENT TEMP (Error Code 19)** - Heating element has exceeded the maximum temperature allowed. The alarm sounds, *lower display* reads “**Er19**”, and *upper display* shows “**ERROR ALARM - MAX ELEMENT TEMPERATURE**”. Heating elements are automatically turned OFF and must cool to the acceptable temperature to clear the error. Typical cause of this error is low oil level, which has exposed the heating element. False alarms can occur when preheating **cold** oil at initial startup of a new day. Vigorously stirring oil during preheat will usually prevent, or clear, a false alarm of this type.

### 5.1.10.1 Resolving Controller Errors & Alarms - continued

- **MAX ELEMENT TEMP Post-error Warning (Error Code 07)** - After **Error 19** is cleared, a warning alarm occurs. *lower display* reads “Er07”, and *upper display* reads “MAX ELEMENT TEMP - PRESS [START]”. This alarm notifies user that a maximum element temperature error has occurred and is now cleared. Press [START] key to enter **PREHEAT** mode. Heating elements will not turn ON until [START] key is pressed.

---

- **BAFFLE FILTER MISSING (Error Code 21 - ONLY applies to ventless model)** - Alarm sounds, *lower display* reads “Er21”, and *upper display* reads “ERROR ALARM - BAFFLE FILTER MISSING”. Indicates that the baffle filter is missing or installed improperly. Heating elements are disabled until the condition is corrected. Install the filter, or adjust its position; error will clear when filter is installed properly. See **Section 6.1.2. & 6.1.3, Baffle Filter Removal & Installation.**

---

- **CHARCOAL FILTER MISSING (Error Code 22 - ONLY applies to ventless model)** - Alarm sounds, *lower display* reads “Er22”, and *upper display* reads “ERROR ALARM - CHARCOAL FILTER MISSING”. Indicates that charcoal filter is missing or installed improperly. Heating elements are disabled until the condition is corrected. Install the filter, or adjust its position; error will clear when filter is installed properly. See **Section 6.1.10, Charcoal Filter Installation.**

---

- **CLOGGED FILTER (Error Code 23 - ONLY applies to ventless model)** - Alarm sounds, *lower display* reads “Er23”, and *upper display* reads “ERROR ALARM - CLOGGED FILTER”. Indicates that airflow through the hood has dropped below a minimum level. Generally, means that the charcoal filter is clogged, however other airflow restrictions will also cause the alarm. Heating elements are disabled until the condition is corrected. Replace the charcoal filter and/or inspect for any other obstructions; error clears when proper airflow is restored. See **Section 6.1.10 & 6.1.12, Charcoal Filter Installation & Replacement.**

---

- **E.A.C. DIRTY (Error Code 24 - ONLY applies to ventless model)** - Alarm sounds, *lower display* reads “Er24”, and *upper display* reads “ERROR ALARM - CLEAN THE EAC”. Indicates that the *Electronic Air Cleaner (E.A.C.)* collector cell is excessively dirty, missing, installed improperly, damaged, or has failed. Heating elements are disabled until the condition is corrected. Clean/inspect the collector cell; the error will clear when the condition is resolved. See **Section 7.1.6 through 7.1.9, EAC Filter Operation & Cleaning.**

---

**NOTE: If an error condition cannot be resolved, please contact a factory-authorized service company, or call Giles Technical Support at 800.554.4537.**

### 4.2 Cooking Procedure

This section explains cooking procedures for both **GEF & GEF-VH Series Fryers** ... In most cases, these procedures assume starting with a clean, empty fryer with the basket lift in the UP position.

1. Remove basket from lift carrier arm and set aside.
2. Be sure that both **POWER** switch (1) and **SELECTOR** switch (2) are in the [OFF] position.
3. Be sure the *drain valve* (3) is in the fully [CLOSE] position (handle vertical).
4. Place the **POWER** switch (1) in the [ON] position. The **POWER** light (5) will illuminate. Power-up fryer (and hood) as described in **Section 4.1.9.1, Start-Up Non-VH & Section 4.1.9.2, Start-up VH.**

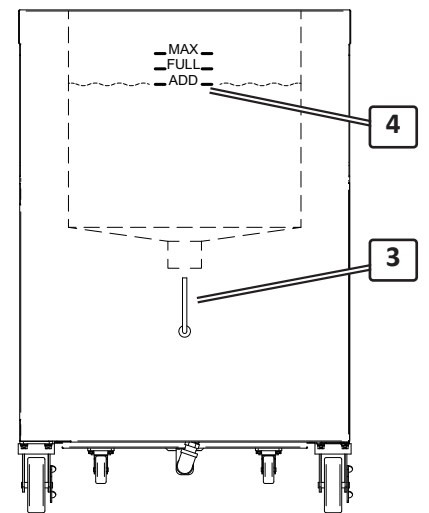

**IMPORTANT!**

*If alarm sounds during power-up and message "ERROR ALARM - DRAIN IS OPEN" is displayed, verify that the drain valve is tightly closed, press the [ALARM] key and follow controller prompts.*

5. Fill the pot with your preferred liquid frying shortening to the [ADD] mark (4) only. When heated, oil expansion should bring level to near the [FULL] mark.

**NOTE:**

*On power-up, controller retains the cook settings for the last load cooked. Skip step #6 if you wish to continue using these settings.*

6. Use keypad (6) to manually set a new cooking temperature and time, see **Section 4.1.3, Manually Setting a Temperature & Cook Time.**  
-- OR --  
Choose a new controller *Menu Item Preset*, see **Section 4.1.4.2, Selecting a Menu Preset.**

7. Controller enters **PREHEAT** using the cooking temperature chosen in **step #6**, or the last used ... real-time oil temperature is shown on *lower display*.

8. Place **SELECTOR** switch (2) in the [COOK] position (*press in top portion of switch*). The **HEAT** light (7) will turn ON and the heating elements energize to begin heating oil to temperature setpoint.

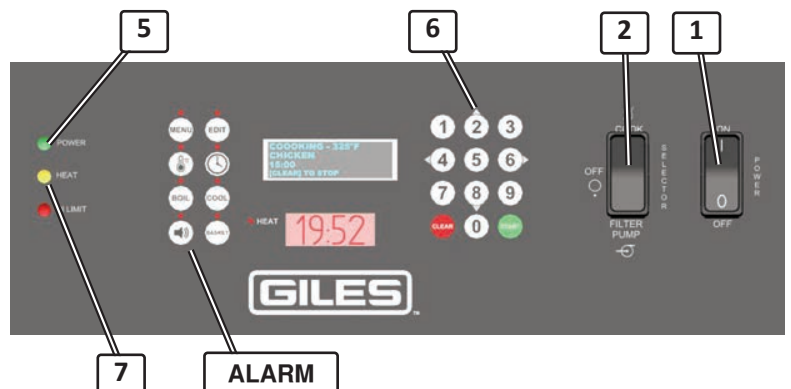

Continued on Next Page

4.2 Cooking Procedure - continued



**Cooking oil is extremely HOT! Contact with unprotected skin will cause serious injury. Always wear thermal protection, such as oven mitts or gloves.**

9. As cooking oil heats, use the provided *stirring utensil* to frequently stir oil from bottom of pot to the top. This stirring action will mix the total volume of oil and prevent formation of cool zones, resulting in more even heating and help prevent occurrence of a false **HI-LIMIT** alarm when first heating cool oil.

10. When oil initially reaches setpoint temperature, the heating elements and **HEAT** light (7) will turn OFF.

11. An alarm sounds and message “**ALARM - STIR OIL**” is displayed on the *upper display*.



Press the **[ALARM]** key and vigorously stir oil. If oil temperature drops below setpoint during a *10 sec.* controller delay, fryer remains in **PREHEAT** until setpoint is reached again. A second alarm sounds and message “**ALARM - SETPOINT REACHED**” is displayed. Press **[ALARM]** key and fryer enters **READY** state. The value displayed in the *lower display* changes from real-time actual temperature to the setpoint temperature.

**Fryer is now ready for cooking ...**

12. Check the oil level. It should now be at (or near) the **[FULL]** level mark (8). If necessary, add more oil to raise level and stir. If the **HEAT** light turns **ON** after adding oil, continue stirring and wait until it turns OFF again and fryer returns to **READY** state before cooking.

13. Place the cook basket (9) onto the *basket lift carrier arm*.

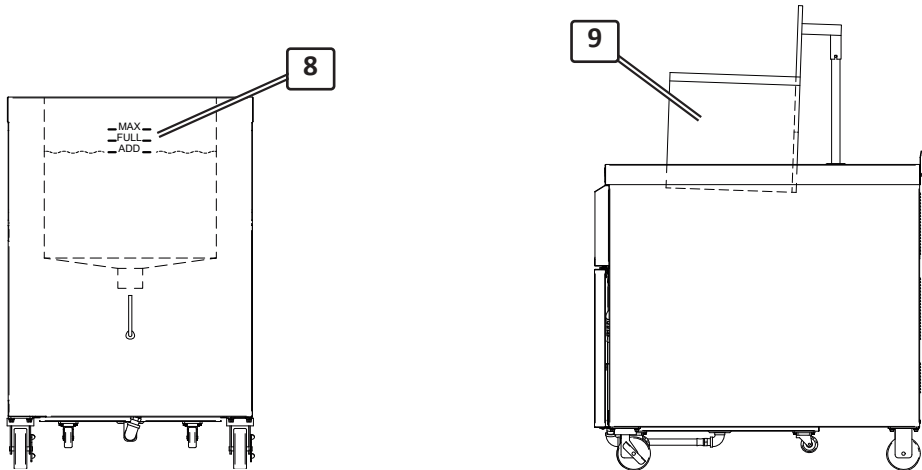

**During cooking operations, oil level MUST be maintained above the minimum [ADD] level. Failure to do so may cause power to heating elements to shutdown.**

### 4.2 Cooking Procedure - continued

14. Current fryer cook settings are shown on the *upper display* ⑩ along with message “[START] TO COOK”. The “READY” notification indicates fryer is ready to cook.

Different cook settings may be entered by following the steps shown **Section 4.1.3** or **Section 4.1.4.2**

**DO NOT exceed recommended full loads for bone-in, 8-way cut chicken as follows:**

- GEF-400: 14 lbs.
- GEF-560: 19 lbs.
- GEF-720: 24 lbs.

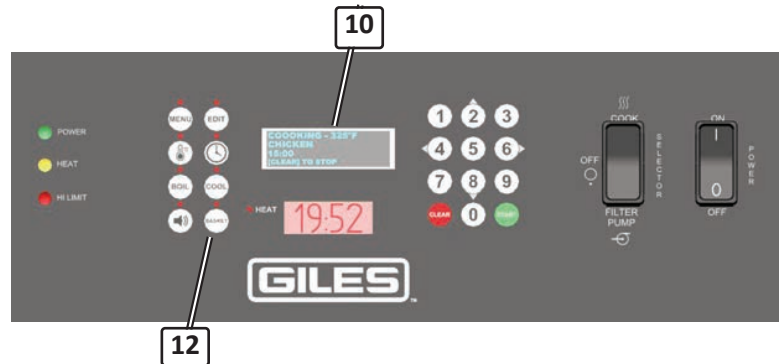

#### **CAUTION**

*If basket is lowered before loading product, use extreme caution when placing food items into HOT oil; skin contact, or splash, can cause serious injury. Always wear thermal protective gear (gloves or mitts).*

15. Uncooked product may be placed in the basket ⑪ either before or after it is lowered into hot cooking oil.
- To manually lower basket before loading, press [BASKET] key ⑫, then press [8]-down key on keypad to lower. **NOTE: Basket lift will not operate unless controller indicates READY.**
  - OR —
  - Load product into basket while lift is in the UP position.
16. Press [START] key to begin cook cycle. If UP, basket lift automatically lowers and the cooking timer begins countdown, which is shown on *lower display*. **Controller must be in READY state before a cooking cycle will begin.**
17. Place *Basket Cover* ⑬ on top of pot.

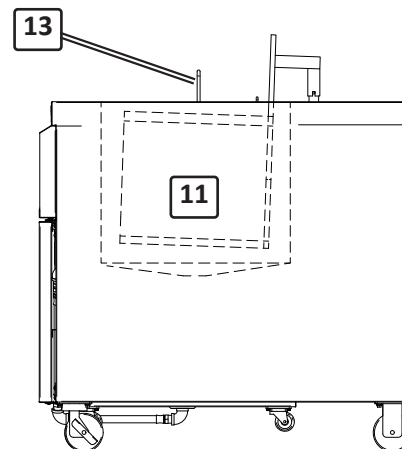

4.2 Cooking Procedure - continued

NOTE:

Step #18 applies only if the user setting [STIR ALARM ENABLE] = ON and the menu preset [STIR OVERRIDE] = NORMAL for item being cooked.

— OR —

[STIR ALARM ENABLE] = OFF and [STIR OVERRIDE] = FORCE.

If these settings are not in effect, **NO** alarm will sound.

Regardless of settings, it is recommended that product be stirred at some point during the last half of the cook cycle to help promote even cooking and prevent pieces from sticking.

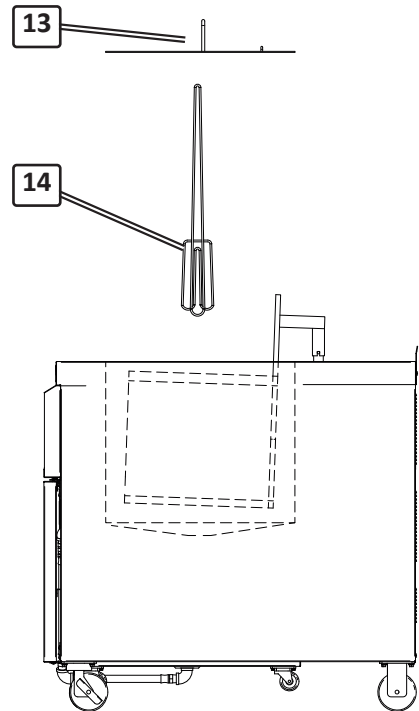

18. The **STIR ALARM** sounds after a preset amount of programmed cook time has elapsed. The *upper display* reads “**ALARM - STIR**” Press the [ALARM] key to silence. **Wear thermal hand protection**, remove the *basket cover* (13) and stir & agitate the cooking product with the provided *stirring utensil* (14) to separate pieces, then replace basket cover.

19. At the end of the cooking cycle, the basket (11) and cooked product will automatically be raised from the oil. An alarm sounds and message “**DONE COOKING**” is shown on the *upper display*. Press the [ALARM] key to silence alarm ... fryer returns to **READY** state awaiting the next load.

20. Public health regulations and food service business guidelines typically mandate that the internal temperature of cooked protein products indicate a prescribed level of doneness before being sold for consumption. In accordance with your specific standard operating procedures, internal temperature of cooked products should be checked for doneness after the cooking process is completed. Check internal temperature of some larger pieces with a digital probe-style food thermometer. Should temp be lower than required, additional cooking time is needed.

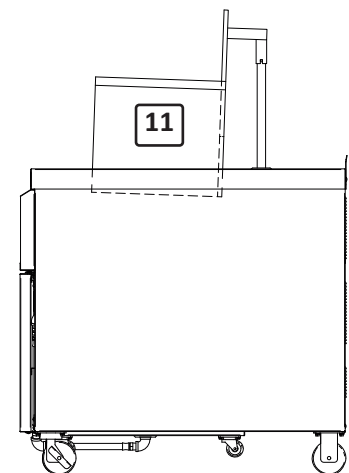

The fryer controller has a feature that allows operator to easily add needed amounts of additional cooking time by pressing the [0] key + **no. of mins. to add**. This can be done either after a cycle is complete, or while it is still active. To use this feature, the *user setting* “[0] KEY EXTRA TIME” must be set to **ON**. See Section 4.1.7, *User Settings*.

### 4.2 Cooking Procedure - continued

21. After verifying doneness, allow cooked product to adequately drain, then remove *basket* from carrier arm and dump product into an appropriate dump station, or food service pan.

Always comply with health regulations pertaining to holding temperature & times for foods prior to sale.

22. To cook another load - return to **Step #12** of this procedure.

To place fryer into standby **COOL** mode - see **Section 4.1.6.2, Cool Mode**.

To shutdown fryer - see **Section 4.5, Normal Shutdown**.

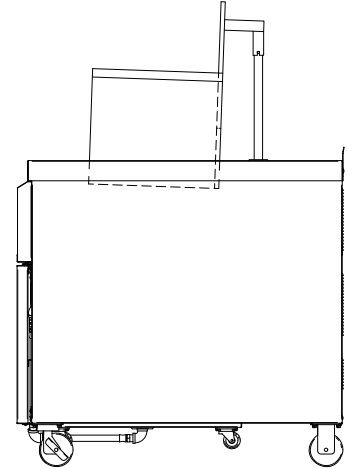

#### **IMPORTANT!**

*In an attempt to promote oil drainage or to dislodge cooking residue, **DO NOT** forcefully strike the basket (full or empty) against the edge of the fryer cabinet, rim of the pot, the basket carrier arm or any other hard surface. Doing so will damage the basket and appliance ... such damages are not covered by the factory warranty.*

**4.3 Filtering Used Cooking Oil**

This section explains use of the on-board *Oil Filtration System* to filter and recondition used cooking oil. The system pumps oil through filter media in the *filter pan* and circulates it back to the fryer pot. Routinely performing this procedure can increase the useful life of cooking oil by as much as 50%.

**GEF & GEF-VH** fryers are equipped with a **FORCE FILTER** feature, which can be set to force operating personnel to perform an oil filtering process according to specific management preferences. The feature is configured in *User Settings*, see **Section 4.1.7 ...**

- **FORCE FILTER** - [ON] or [OFF] • **Factory-set default = [ON].**  
 [ON] = After completing a set number of cook cycles (defined by **FILTER COUNT**), alarm sounds and the message **“ALARM - MUST FILTER OIL”** is displayed on *upper display* screen. Pressing the [ALARM] key silences alarm and fryer enters **FILTER MODE**. Appliance will be disabled from continued operation until the filtering process is properly completed, as described in the section.  
 [OFF] = After completing a set number of cook cycles (defined by **FILTER COUNT**), alarm sounds and the message **“ALARM - FILTER OIL”** is displayed on *upper display* screen. Pressing the [ALARM] key silences alarm and the fryer returns to **READY** state ... the appliance is not disabled. You may continue to cook, however this alarm will sound and the notification displayed after every subsequent cook cycle until oil filtering is done.
- **FILTER COUNT** - 1 to 20 • **Factory-set default = 4.**  
 The number of cook cycles that can be performed before fryer enters **FILTER MODE**.
- **FORCE FILTER SNOOZE** - [ON] or [OFF] • **Factory-set default = [OFF].**  
 Effective only when **FORCE FILTER** is turned [ON].  
 [ON] = Allows operator to cook **one (1) additional load of product** after **FILTER COUNT** has been reached, before fryer enters **FILTER MODE** and is locked-out.  
 [OFF] = **No** additional cook cycles is allowed.

In addition to global **FORCE FILTER**, each *Menu Item Preset* has a **FISH FILTER** setting ... when set [ON], it overrides the global setting and fryer enters **FILTER MODE** after cooking **only (1) batch** of the particular menu item. This feature is typically used for seafood items to attempt to minimize possibility of flavor transfer to other foods cooked with the same fryer. See **Section 4.1.4.1, Editing a Menu Item Preset** for more detail.

**CAUTION** DO NOT attempt to filter cold, congealed oil. Filter pump damage or malfunction may occur. Oil should be a minimum of 200°F (93°C) before attempting to pump.

1. After cooking the preset number of loads defined by [FILTER COUNT] the alarm sounds.

2. If **FORCE FILTER = OFF**, display ① reads **“ALARM - FILTER OIL”**, press [ALARM] key ② to continue. **To continue to alert operator that oil needs filtering, this alarm notification will occur after each subsequent load cooked, until the oil in fryer is filtered.**

If **FORCE FILTER = ON**, display ① reads **“ALARM - MUST FILTER OIL”**, press [ALARM] key ②.

Fryer enters **FILTER MODE** and is **disabled from continued operation** until the oil is properly filtered.

3. Place **SELECTOR** switch ③ in [OFF] position. **IMPORTANT! The POWER switch must remain [ON] during the filtering process.**

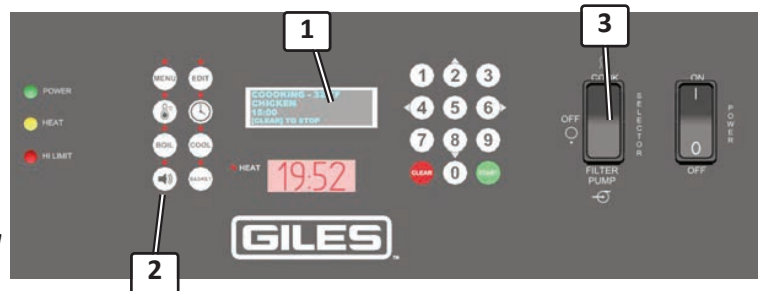

### 4.3 Filtering Used Cooking Oil - continued



Always wear thermal protection, such as gloves or oven mitts, while performing the filtering process. Fryer parts inside cabinet can be very HOT!

4. Open cabinet and disconnect the *Filter Pan Hose* (4) (push in white slip-ring & pull hose from coupling) ... remove *Filter Pan* (5) from unit.
5. Remove *Filter Pan Cover* (6) and check that filter media (typically, 1 sheet of filter paper) is in place and that any residue from a previous filtering has been cleaned from the surface. Ensure that *Hold-down Frame* is properly locked in place.
6. Evenly distribute approximately **5 ozs** of a suitable **filter aid** product over the filter media surface. Using a good quality filter aid product is essential for removing soluble impurities and reconditioning the oil. **Portion packed Filter Powder is available from Giles dealers & distributors ... Item #72004.**

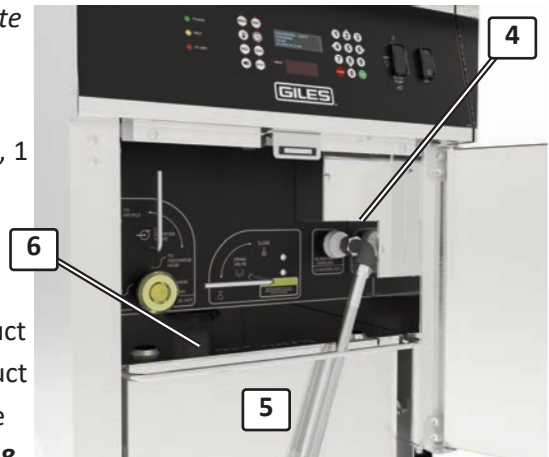

7. Replace *pan cover* and reposition the assembled *filter pan* under fryer ... reconnect *filter pan hose* (4) (push in white slip-ring while inserting brass fitting into coupling). **Ensure that the hose fit is tight and secure.**



The next steps will drain cooking oil from the pot into the filter pan, exposing the heating elements. Fryer is equipped with safety interlocks that disable heating elements anytime the drain valve is opened. As a further safeguard, to reduce risk of oil fire, always place control panel **SELECTOR** switch in the [OFF] position prior to draining. **NEVER CONSIDER THE DRAIN VALVE AS THE "ON/OFF HEAT SWITCH"**.

8. Ensure control panel **SELECTOR** switch is in the [OFF] position ... **POWER** switch must remain [ON]. Place the **OIL DIVERTER VALVE** (7) in the [TO FRYPOT] position (vertical). Slowly turn the **DRAIN VALVE** handle (8) to the [OPEN] position (horizontal). Allow all used oil to completely drain into *filter pan* (5).

**NOTE:**

**Be sure filter pan cover is in place while draining. Doing so will help contain oil splash and splatter.**

If pot does not drain readily, use the provided **Kettle Drain Brush** to break up crumbs or debris that might be blocking the drain opening. **Be careful not to push brush so far down as to puncture filter media in the filter pan. Doing so could allow excessive debris to enter the filter pump and potentially clog and damage it.**

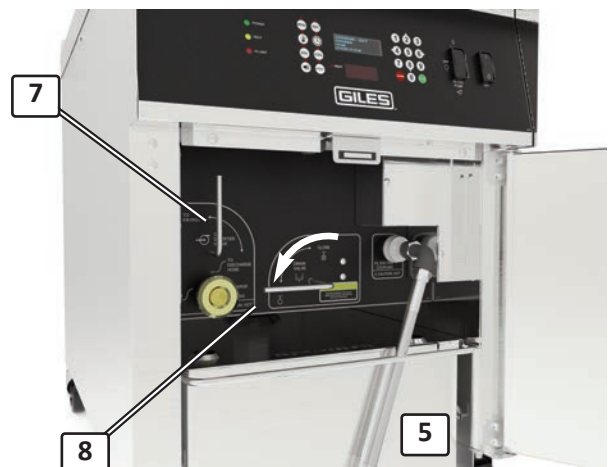

Continued on Next Page

4.3 Filtering Used Cooking Oil - continued

9. When oil has *completely drained* from pot into the *filter pan*, place the **SELECTOR** switch (9) in the **[FILTER PUMP]** position.

10. The filter pump starts ... oil is drawn through the filter media and filter aid, then is pumped back into the pot. **Leave drain valve open and allow oil to continually recirculate to act as a “crumb wash” to flush residue down into the filter pan.** During this time use the provided *heat-resistant brushes* to scrub residue from pot surfaces and heating elements. Use *round bristle brushes* to clean between pot wall & elements. Allow recirculating oil to flush the pot.

11. After approx. **5 mins**, return *Drain Valve* handle (10) to the **[CLOSE]** position (vertical) and allow pump to run until the pot refills with the filtered and reconditioned oil.

12. When oil has been pumped completely back to pot, place the **SELECTOR** switch (11) in the **[OFF]** position (centered) to stop pump.

13. Be sure oil level is at the **[FULL]** level mark, add if needed.

14. **Wear thermal hand protection**, disconnect *filter pan hose* (12), remove the *filter pan* from cabinet and lift off cover.

15. Use the provided *Crumb Scoop* (13) to scoop filter sediment from the surface of the filter media and discard. *Unless there are obvious holes or tearing, it is not necessary to replace the filter media after every filter cycle.*

**IMPORTANT! At a minimum, the filter pan should be thoroughly cleaned and the media refreshed DAILY, see Section 5.2, Cleaning Filter Pan & Replacing Filter Media.**

16. Replace *pan cover* and reinstall *filter pan* in fryer cabinet ... connect hose.

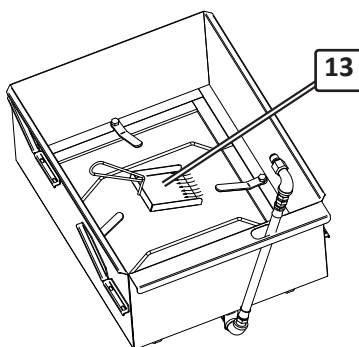
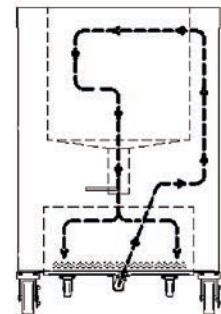
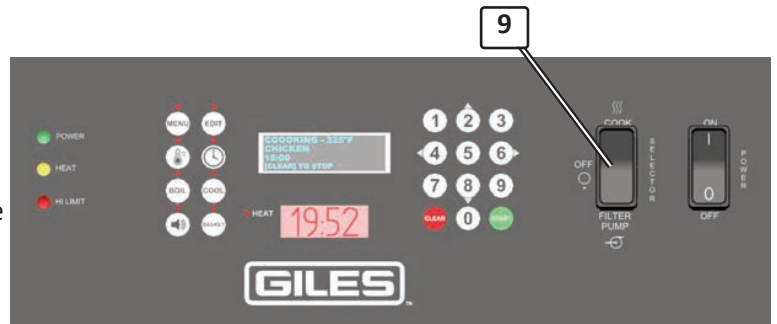

Continued on Next Page

### 4.3 Filtering Used Cooking Oil - continued

17. To continue cooking, refer to **Step #6, Section 5.2, Cooking Procedure**.

To discontinue cooking, see **Section 5.5, Normal Shutdown**.

#### IMPORTANT!

When **FORCE FILTER** is [ON], the fryer will not exit **FILTER MODE** and return to normal operation unless the controller detects, 1). opening of the drain valve, and 2). an oil temperature that is less than the [FILTER RESET] temperature parameter specified in *user settings*. Generally, oil will cool sufficiently while filtering to reset the controller ... *factory-set default = 290°F*.

The **POWER** switch must remain [ON] throughout the entire filter process to allow controller to reset properly from **FILTER MODE**. If switch is turned [OFF], controller will not detect drain opening or oil temperature ... it will not reset.

### 4.4 Removing Waste Cooking Oil from Fryer

This section explains the procedure for removing and disposing of waste cooking oil. To maintain the quality of foods cooked, oil should generally be changed every **7 to 10 days**, depending on your filtering practices, types of foods and quantities cooked regularly. Oil must also be removed before a *Boil-Out procedure* is performed.

In this section a *Giles Oil Caddy (not provided)* is referenced as waste oil handling equipment.



**DO NOT** attempt to filter cold, congealed oil. Filter pump damage or malfunction may occur. Oil should be a minimum of 200°F (93°C) before attempting to pump.

1. If cooking oil is cold, *preheat to 200°F (93°C)*.
2. Be sure the **POWER** switch ① and **SELECTOR** switch ② are both in the [OFF] position.
3. Open cabinet and ensure *filter pan* ③ with filter media is in place and the *filter pan hose* ④ is properly connected to fryer.
4. Slowly turn **DRAIN VALVE** handle ⑤ to the [OPEN] position (horizontal) and allow pot to completely drain.

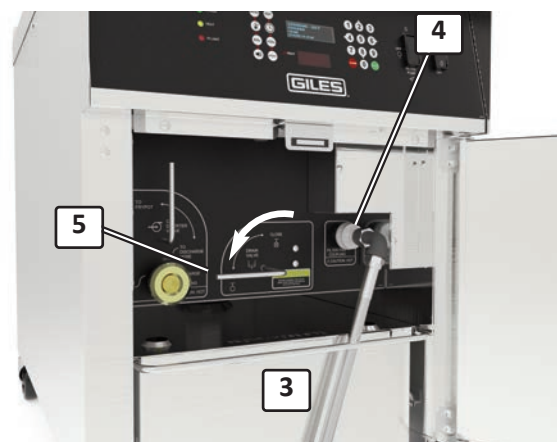

Continued on Next Page



### 4.4 Removing Used Waste Cooking Oil from Fryer - continued

10. After waste oil is removed from *filter pan*, place the **SELECTOR** switch (12) and **POWER** switch (13) in the **[OFF]** position.
11. Return **OIL DIVERTER VALVE** handle (14) to the **[TO FRYPOT]** position (vertical).
14. ***Wear thermal protection!*** Remove *discharge hose* from the **DISCHARGE HOSE** coupling (15) and drain any oil remaining in it into the disposal container.
15. Allow the *filter pan* to sufficiently cool. then remove from unit. Disassemble and clean thoroughly, as described in **Section 5.2**.
16. After removal of waste oil, a **Boil-Out** procedure should be performed promptly. See **Section 5.1, Boil-Out Procedure**. ***DO NOT*** allow oil residue to remain in the pot for any extended period of time. It will dry and become very difficult to clean away ... eventually could lead to an undesirable build-up that can negatively impact fryer performance and food quality.
  - ◇ If **Boil-Out** must be postponed ... at a minimum, use absorbent paper wipes to clean as much of the waste oil residue, as possible, from the pot surfaces and heating elements, then clean the *filter pan*, refill fryer with fresh oil, and restart as described in **Section 4.2, Cooking Procedure**.
17. To perform a **Boil Out**, see **Section 5.1, Boil Out Procedure**.

To shutdown fryer, refer to **Section 4.5, Normal Shut-Down**.



4.5 Normal Shut-Down

1. Place **SELECTOR** switch ① and **POWER** switch ② in the [OFF] position.
2. Confirm that **POWER** light ③ turns OFF.
3. To completely remove power from the appliance, turn **OFF** circuit breakers in main electrical panel providing power to the unit.



4.6 Emergency Shut-Down

In case of emergency, shutdown power to this and all other food service equipment in accordance with your business standard emergency down procedures.

### 5. Cleaning

This section describes procedures for cleaning and maintaining models *GEF & GEF-VH Series Fryers* that are necessary to keep the appliances in good operating condition. **General cleaning of the appliance should be performed daily** and other activities should be performed as described by the following.

#### **⚠ DANGER**

**DO NOT** wash down the interior or exterior of fryer with water from a spray hose, or any pressure washing equipment.

Failure to comply with DANGER notices will result in death or serious injury, equipment or property damage, and void the warranty.

#### 5.1 Boil-Out Procedure (Cleaning the Fryer Pot)

The following explains a **Boil-Out Procedure** that is used for cleaning & degreasing the fryer pot and heating elements. The procedure must be performed before first use of a new appliance and should be performed promptly before refilling fryer with fresh cooking oil after used waste oil is removed and discarded.

**Generally, for proper maintenance and to ensure satisfactory operation and food quality, the procedure should be performed every 7 to 10 days, however, exact timing of oil replacement is dependent on many factors. Oil test kits, which can help accurately determine oil condition and when replacement is needed, are available from most restaurant supply companies.**

#### **⚠ CAUTION**

- A boil-out process does not actually involve a rolling boil ... nevertheless, **DO NOT** leave a fryer unattended during the procedure. Careful monitoring is needed to guard against accidental overflow, which could result in serious equipment damage.
- The fryer and boil-out solution in the pot will become very HOT ... always wear thermal hand protection when performing the procedure, as well as use other personal protective equipment (*face-shield, latex apron, etc.*).
- When using *fryer degreaser/cleaner products*, closely follow the manufacturer's usage instructions. Products may contain chemicals, which require special precautions and if used improperly could cause equipment damage and/or personal injury.

1. Remove waste cooking oil from the fryer as described in **Section 4.4, Removing Waste Cooking Oil**.
2. Confirm that the **DRAIN VALVE** handle ① is in the fully **[CLOSE]** position.
3. Ensure that control panel **SELECTOR** switch is in the **[OFF]** position.
4. Use absorbent disposable wipes to clean as much waste oil residue as possible from pot and heating elements ... begin filling pot with clean ambient temp water.
5. Use a reputable **fryer cleaning** product and carefully follow the manufacturer's usage directions. Add the recommended amount to pot while filling and stir to mix ... fill to the **[FULL]** level mark ②.

**Fryer Boil Out** cleaner is available through *Giles equipment dealers and distributors* ... Item number: #72003-1, 8-lb Jar or #72003, Case of 4 Jars.

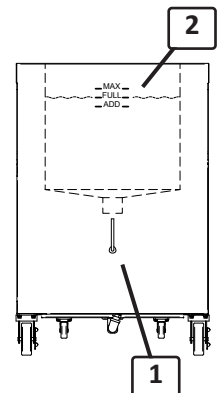

5.1 Boil-Out Procedure (Cleaning the Fryer Pot) - continued

5. Place the **POWER** switch ③ in the [ON] position.
6. Place the **SELECTOR** switch ④ in [COOK] position.
7. After controller powers-up and alarm sounds, press [START] key to begin **PREHEAT** ... amber **HEAT** light on control panel turns ON, solution begins heating. Note upper display reads "**PRESS [BOIL] - GO TO BOIL-OUT**". Press the [BOIL] key ⑤ to place fryer into **BOIL OUT** mode. Temp setting changes to **200°F (93°C)** and time begins countdown from **30 mins**. *These are the factory default settings which can be changed in user settings, Section 4.1.7.*

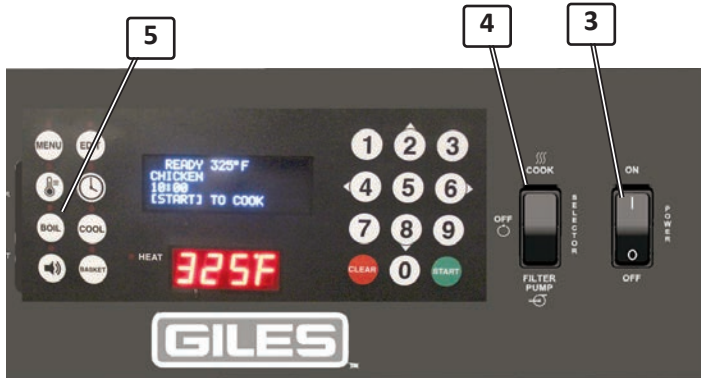

8. Allow boil out cycle to run completely. When boil out cycle time expires, the "**DONE COOKING**" alarm sounds ... place both **SELECTOR** ④ and **POWER** ③ switches in the [OFF] position.
9. Disconnect and remove *filter pan* from fryer.

**NOTE:**  
As a safeguard, when the boil out cycle ends, the controller temperature setpoint automatically changes to 50°F. Before cooking activities can resume, a menu item preset must be re-selected, or temperature setpoint must be manually re-entered.

**IMPORTANT!!**  
DO NOT drain boil-out solution into the filter pan or run through filter pump! It is corrosive and will damage components. Equipment damages and/or malfunctions caused in this manner will not be covered by the factory warranty.

10. Position a suitable *heat resistant catch container* ⑥ (not provided) beneath the fryer drain.

**CAUTION** The catch container used for this step should be heat resistant up to 300°F (148°C). Plastic is generally not acceptable, as it may soften and crack. A leak-proof metal container should be used. Failure to comply with this caution may result in personal injury.  
If a floor drain is available in a suitable nearby location, slowly draining solution onto floor and squeegeeing the liquid into drain is an acceptable alternative (requires a helper).

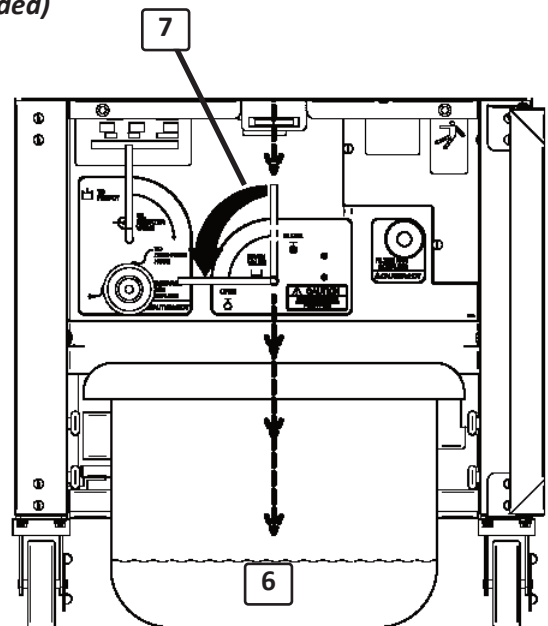

11. Slowly turn the **DRAIN VALVE** handle ⑦ to the [OPEN] horizontal position and drain boil-out solution from pot. If using catch container, carefully monitor and empty as needed. As solution drains, you can scrub heating elements and pot surfaces with the provided brushes.
12. Rinse and flush pot thoroughly with clean hot water. Empty catch container as often as needed or continue to squeegee to floor drain.

Continued on Next Page

### 5.1 Boil-Out Procedure (Cleaning the Fryer Pot) - continued

13. Dry pot with clean, dry, sanitized towels. Be sure pot surfaces and heating elements are completely dry before refilling with fresh cooking oil.
14. Slowly turn the **DRAIN VALVE** handle ⑧ to the [CLOSE] vertical position.
15. Clean the *filter pan*, replace *filter media* and re-assembled; refer to **Section 5.2, Cleaning Filter Pan & Replacing Filter Media**.
16. Place cover ⑨ on *filter pan* ⑩, reposition assembled pan under fryer and connect *filter pan hose* ⑪ at the quick coupling.
17. To resume cooking, refill pot with fresh liquid frying shortening and restart fryer as described in **Section 4.2, Cooking Procedures**.

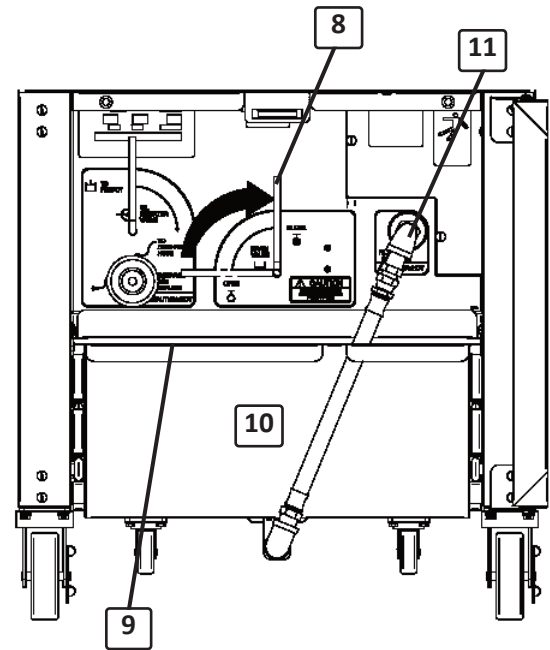

To shutdown, follow prescribed standard procedures; refer to **Section 4.5, Normal Shutdown**.

**5.2 Cleaning Filter Pan & Replacing Filter Media**

This section describes the procedure for cleaning *filter pan* and replacing *filter media*. Must be done after each *Boil-Out Procedure*, as well as part of a *daily cleaning routine*.

*GILES recommends using a non-toxic, non-detergent, biodegradable degreaser cleaner, such as SIMPLE GREEN® Crystal Foaming Spray Cleaner/Degreaser along with hot water, to clean the filter pan and its components.*

**CAUTION** Wear thermal hand protection as safeguard from hot parts.

1. Shutdown fryer using *Normal Shut-Down*, see *Section 4.5*.
2. Disconnect & remove *filter pan* ① from fryer and lift off *cover* ②. Clean and dry cover thoroughly.
3. If equipped, remove the *Crumb Screen*\* ③, clean and dry it thoroughly.
4. Using the metal *crumb scoop* provided with the unit, remove accumulated filter residue from the surface of the media ⑤, especially around the edge of the *Hold-Down Frame* ④.
5. Turn locking *levers* ⑥ to disengage the *hold-down frame* from *filter pan*. Remove frame, clean and dry thoroughly.
6. Grasp edge of *soiled sheet of filter paper* ⑤ and carefully roll it up, taking care to not allow filter debris to fall through perforated screen in the pan bottom ... discard waste sheet.
7. Clean *filter pan*, rinse thoroughly and dry completely. Be certain to drain all water from filter pan hoses.
8. Reassemble *filter pan*, using one (1) fresh sheet of *filter paper* (proper size 15-1/2" x 21-3/8"). Replace hold-down frame & close all locking levers ... be sure they securely engage the *frame*.
9. Replace *crumb screen*\* & *pan cover*, as needed. Place assembled *filter pan* under fryer and reconnect hose at the quick-coupling.

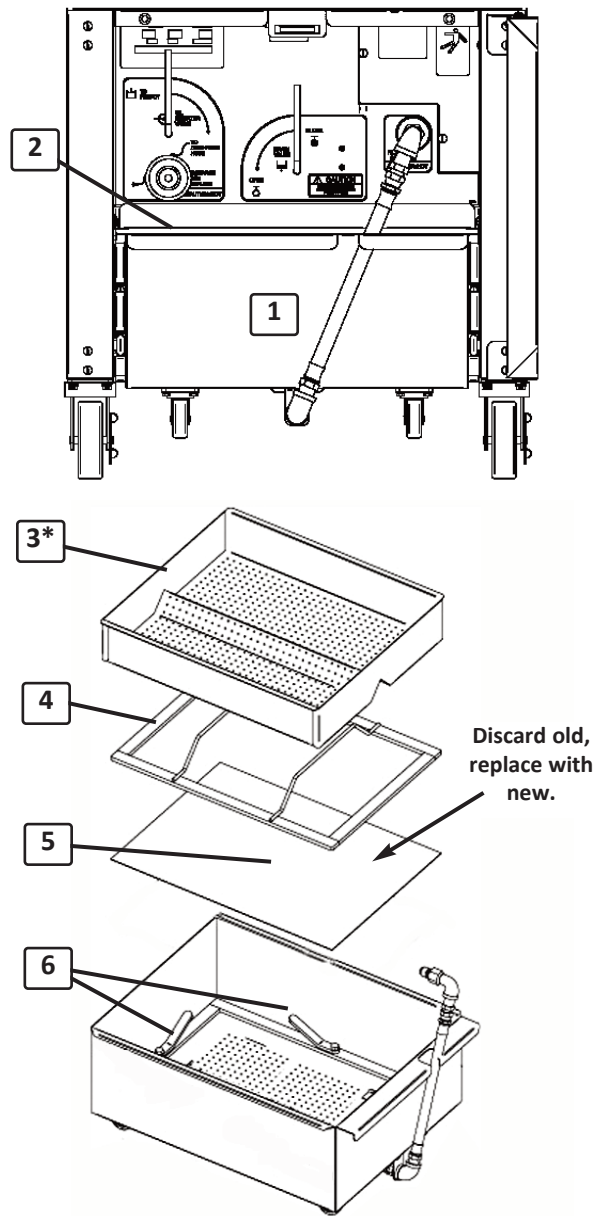

\* Purchased separately, not provided

**IMPORTANT!**

At a minimum, the *filter pan* must be cleaned & filter media replaced daily, as described here. Doing so will help keep the on-board oil filtration system operating at peak performance. Some food service operators may wish to perform this more often as a standard practice.

## 6. Ventless Hood

*This section applies **ONLY** to GEF-VH Ventless Hood Fryers and explains operation, maintenance and service procedures specific to the **integral ventless hood system**. The hood is a recirculating system that captures and removes grease-laden cooking vapors generated by the fryer. Air is cleaned & filtered before being exhausted back into the room. The hood does not require ducting to the outside, however, to ensure satisfactory performance, the installation site and application must comply with limitations and requirements, defined in **GILES Hood Approval Document (HAL)**.*

**IMPORTANT!** *The appliance will **NOT** power-up if the filter Access Cover is missing, or ajar. The sides of the cover must seat flush against the hood front and the pin on the right-hand edge must engage the interlock switch inside the hood wall. The fryer will **NOT** heat unless **ALL** hood filters are in place.*

### 6.1 Filters



The following explains each **filter** within *ventless hood system* and explains filter removal, installation & cleaning, and the alarm conditions that can occur if not maintained properly. The following steps must be performed as described to keep the ventless hood operating at peak performance to remove grease-laden vapor.

#### 6.1.1 Ventless Hood Filters

Filter	When to Clean or Replace	How to Remove	How to Clean	How to Install
Baffle Filter	Clean Daily	Section 6.1.2	Section 6.1.4	Section 6.1.3
E.A.C. Filter Cell	Clean Daily	Section 6.1.5	Section 6.1.9	Section 6.1.6
Charcoal Filter	Replace approx. every 30-40 days <b>P/N 30248</b>	Section 6.1.10	<b>Cannot be cleaned ONLY REPLACE</b>	Section 6.1.11

- **BAFFLE FILTER:** First stage of the air cleaning process. Entraps and collects larger grease particulate generated while cooking. Condensate drains into a collection gutter and is directed to a drip cup beneath the filter. **Generally, this filter is dishwasher safe.**
- **ELECTRONIC AIR CLEANER [E.A.C.] COLLECTOR CELL:** Second stage of the air cleaning process. Contains ***fine ionizer wires*** and a ***bank of thin metal collection fins***. The system negatively charges fine grease particulate in the air stream, allowing it to be electrostatically captured on the collection fins. The cell must be cleaned **EVERY DAY** with a non-caustic degreasing cleaner. The fryer features a **Cleaning Timer** that will remind operators to clean the cell ... the timer system will shutdown fryer and disable it from continued operation until the collector cell is cleaned.
- **CHARCOAL FILTER:** Third stage of the air cleaning process. The activated carbon filter ***helps to control cooking aromas*** in the exhausted air. The filter is a consumable item (*single use*) that **MUST** be replaced approximately every **30 to 40 days**, depending on cooking activity. **The filter CANNOT be cleaned and reused.**

6.1.2 Baffle Filter Removal

 <p><b>WARNING</b></p>  <p>Sharp edges Watch your fingers</p>	<p>The baffle filter has sharp exposed edges, which may cause cut injury. Use due caution when handling and cleaning the filter. Heavy duty rubber gloves are advised.</p>
---	--

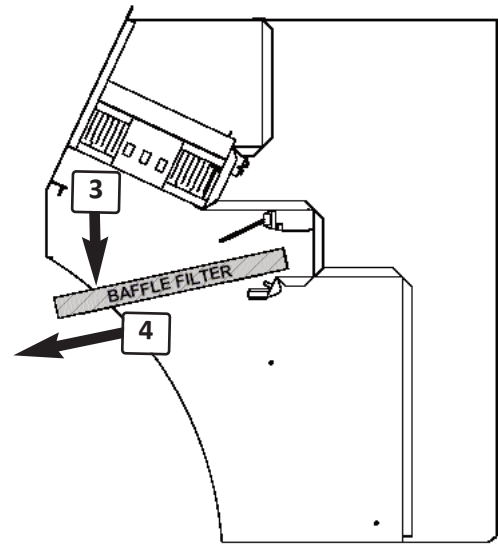
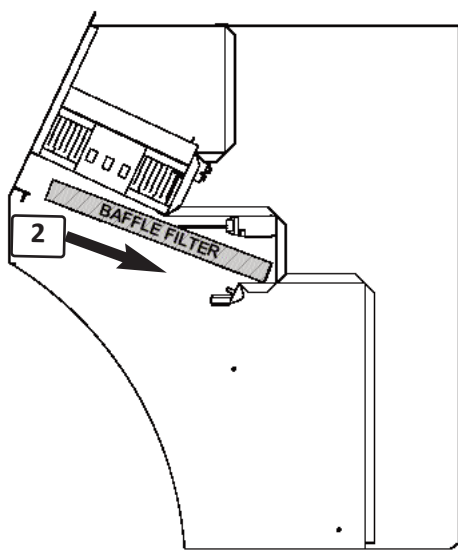
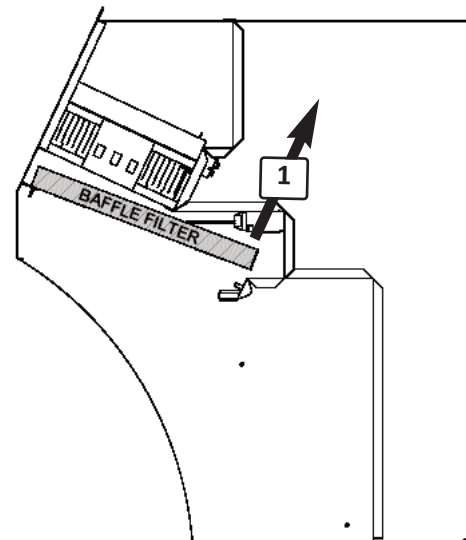
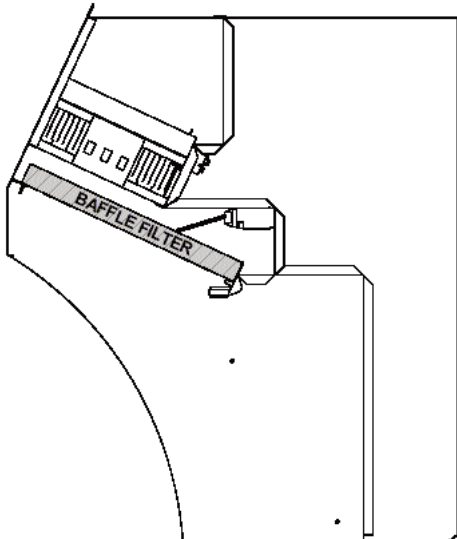

- ① Turn OFF power ... reach under hood & lift rear edge of filter enough to clear the edge of **rear support channel**.
- ② Slide filter toward the back of the hood to allow front edge to clear **front support ledge** drop downward.
- ③ Drop front edge down to clear **Front Header** panel.
- ④ Remove filter from hood.

## 6.1.3 Baffle Filter Installation

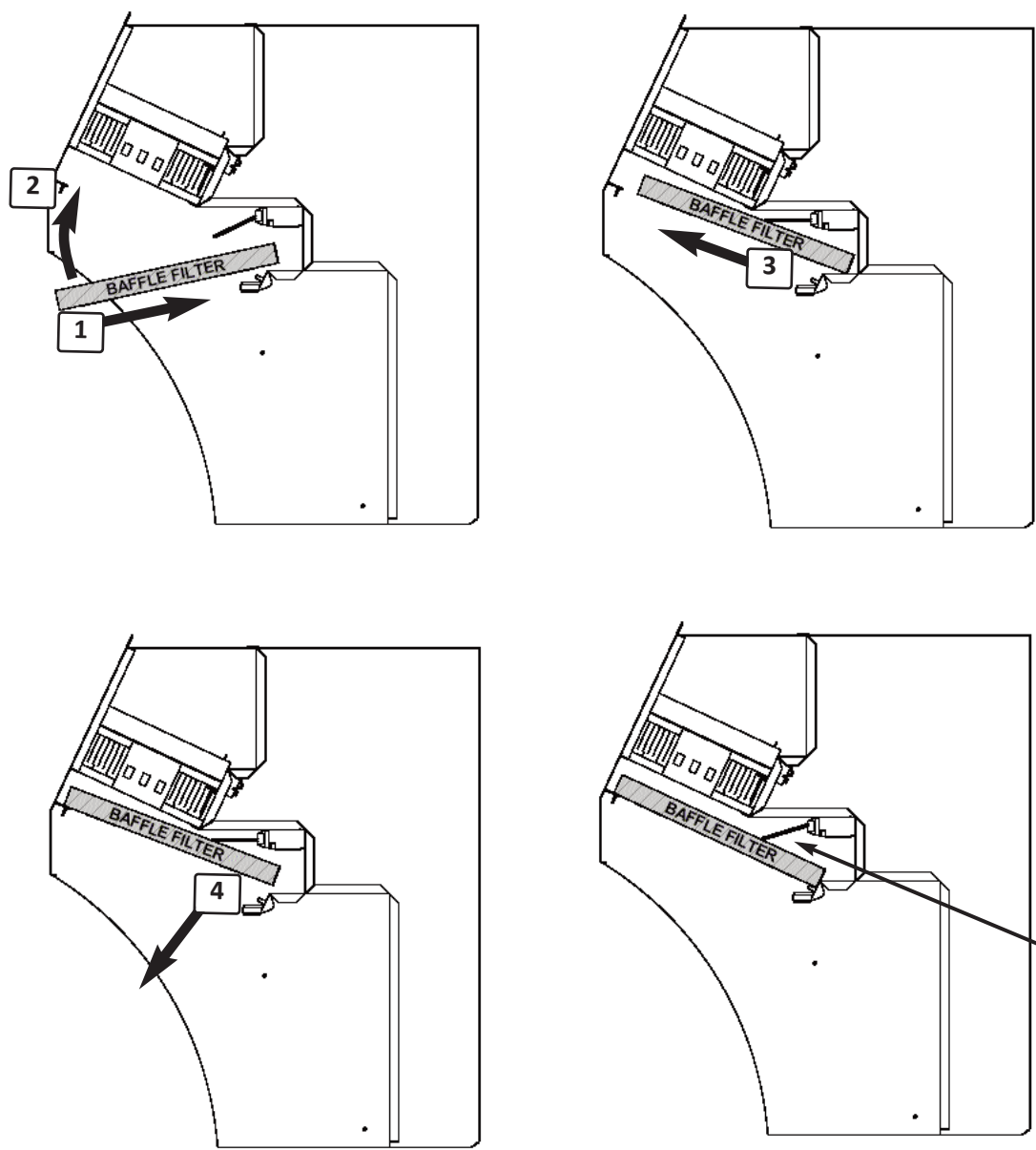

<p><b>WARNING</b></p>  <p>Sharp edges Watch your fingers</p>	<p>The baffle filter has sharp exposed edges, which may cause cut injury. Use due caution when handling and cleaning. Heavy duty rubber gloves are advised.</p>
---	---



- ① Insert back edge of filter into hood, *fully to the back wall*.
- ② Lift front edge up behind **Front Header** panel.
- ③ Pull filter forward until front edge rests on **support ledge** inside **front panel**.
- ④ Allow back edge to drop down and rest on the **(2) studs in rear channel**.

**IMPORTANT!** As shown above, the filter body must engage and actuate the curved switch lever located at the right rear of hood. Filter must be installed so that the slats & slots are in a vertical orientation, NOT horizontal.

**6.1.4 Baffle Filter Cleaning**

 <p><b>WARNING</b></p>  <p>Sharp edges Watch your fingers</p>	<p><i>The Baffle Filter has sharp exposed edges, which may cause cut injury. Use due caution when handling and cleaning. Heavy duty rubber gloves are advised.</i></p>
---	--

Generally, the *baffle filter* should be cleaned **daily**. Wash filter in sink with a mild degreaser cleaner and warm water. Rinse and dry completely. **Filter must be completely dry before re-installing into hood. Never place wet or damp filter into hood for operation!**

Generally, a *baffle filter* can generally be washed in a dishwasher.

**6.1.5 E.A.C. Filter Cell Removal**

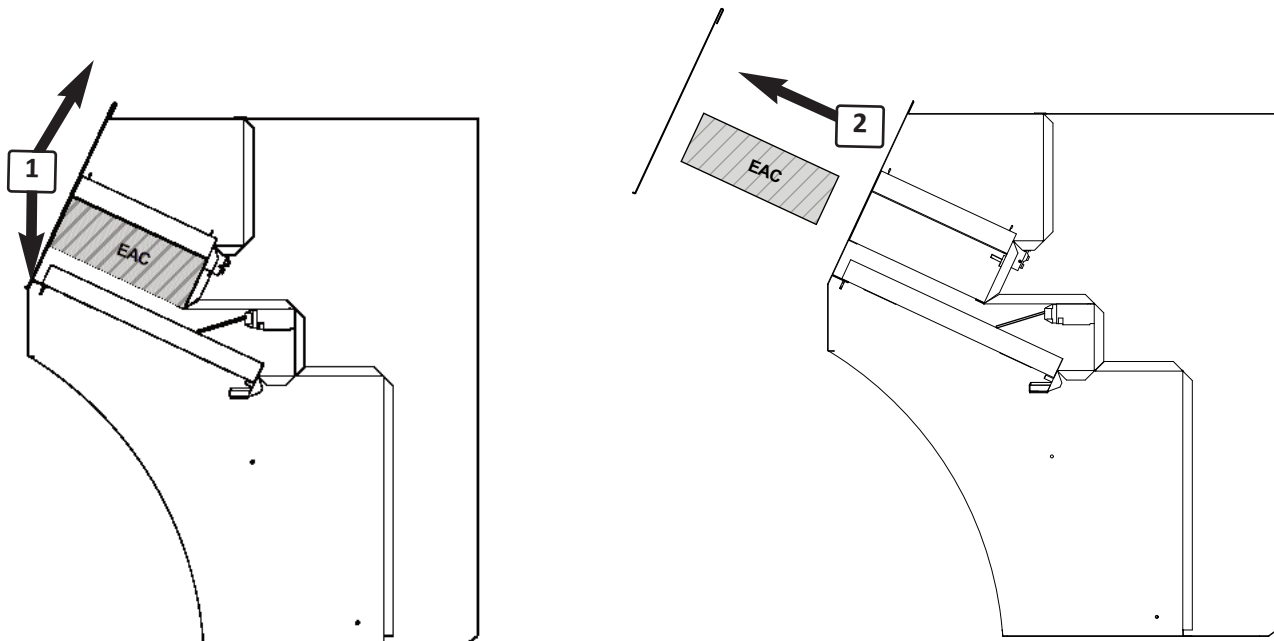

- ① Turn OFF power ... unlatch **Access Cover** and lift off.
- ② Grasp **E.A.C. Collector Cell** handle and pull cell straight out, at a slightly upward angle.

## 6.1.6 E.A.C. Filter Cell Installation

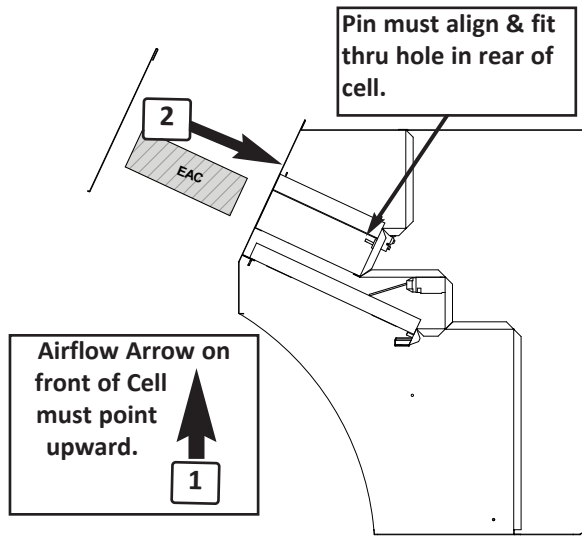

- ① Ensure the airflow indicator arrow points **UPWARD** & the cell's **contact pad** faces to the **right side**.
- ② Align cell in *guides* and slide into hood. If installed properly, the cell will be flush with hood front. **If this not the case, the cell is not installed correctly.**
- ③ Replace *access cover* and latch.

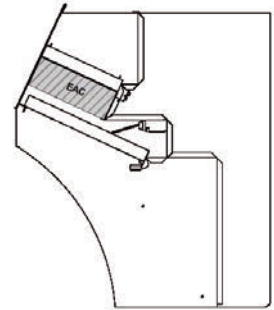

## 6.1.7 E.A.C. Filter Operation Overview - Status & Alarms

The **Electronic Air Cleaner (E.A.C.)** system is designed to electrostatically capture and collect fine grease particulate to remove it from the air stream.

Three **LED indicator lights** on the control panel show the continuous operational status of the system.

**[ON]** Indicates that the cell is installed, powered and operating. This will be the only light ON when the system is operating normally.

**[WASH]** This light turns ON to indicate:

- Filter cell is not installed or is mis-aligned.
- Collection fins contain an excessive amount of captured grease residue.
- Poor connection of cell's contact plate with the hood contacts.
- Too many Ionizer wires are completely missing.

When any of these conditions exist, the **[WASH]** light turns ON to signal that attention is required to avoid fryer shutdown. **Two (2) minutes** after the light turns ON, an alarm sounds and heating elements are shutdown. The message **"ERROR ALARM - CLEAN THE EAC"** is displayed on the *upper display* ①.

**[WASH]** light is **NOT** intended to be the signal for routine *collector cell* cleaning, **DO NOT use as such**. Typically, the collection cell must be cleaned **DAILY** to ensure optimum performance. See **Section 6.1.8, EAC Filter Cell Cleaning**.



**6.1.7 E.A.C. Filter Operation Overview - Status & Alarms • continued**

**[CHECK]** This light turns ON to indicate:

- Ionizer wire broken and touching the cell frame.
- Cell is damaged and has shorted out to ground.
- Collection fins are shorted out because of excessive moisture.

When **[CHECK]** light is ON, the system is no longer operating to clean the air even though the hood and fryer will continue to operate. **Important! controller does not issue an alarm for this condition.**

**DO NOT CONTINUE TO USE FRYER WHEN THIS CONDITION EXIST!**

The following actions may correct the alarm condition:

1. Turn OFF hood **POWER** switch.
2. Remove the E.A.C. cell and clean as described in **Section 6.1.8**.
3. Inspect the cell for broken or missing ionizer wires, bent fins, or other damage. Ionizer wires are replaceable (*when ordering replacements, note length ... 20"*). Bent fins may be gently straightened by hand, so that no fins are touching adjacent fins. A cell with excessive damage (*badly damaged frame, broken insulators, etc*) must be replaced.
4. Inspect the E.A.C. contacts inside hood. Clean grease accumulation away with a mild degreasing cleaner and dry thoroughly.
5. Replace filter cell (**Section 6.1.6**) and restart fryer (**Section 4.1.9.2**). If the alarm condition persists, contact a qualified service company.

**IMPORTANT! If no L.E.D. indicators turn ON up when the fryer is powered up, the E.A.C. system may have an internal malfunction. A call for service is required.**

## 6.1.7.1 E.A.C. Filter Cell Cleaning Timer

This feature was implemented to help operators adhere to a proper cleaning routine for the *E.A.C. Collector Cell*. Timely cleaning is necessary to ensure the hood continues to effectively clean the air. It is a countdown timer which is programmed to issue a **warning** signal, alerting the operator that the *cell* needs to be cleaned **soon**. If no action is taken within an allotted time, a **timeout alert** is issued, the fryer is shutdown and *disabled from continued operation* until cell is cleaned. When cleaning is performed, the timer resets, fryer operation is restored, and a new countdown begins. To avoid the possibility of *lock out*, **performed cleaning DAILY**, as prescribed.

Timer indicators and a **Snooze** control are located on the left side of the fryer control panel.

Details of operation shown below.

### Timer Operation:

- ① **CHANGE SOON**  
The amber indicator light turns ON when the timer enters **[WARNING]** mode. If the *collector cell* is cleaned within the next **24 hours**, timer automatically resets, begins a new countdown and *normal operation continues without interruption*.

- ② **CHANGE NOW**  
The red indicator light turns ON when the timer enters **[TIMEOUT]** mode, to signal that the allowed time between cleanings has expired. An audible alarm sounds and the fryer is shutdown and will remain *locked out of continued operation* until the cell is cleaned.

Place the **POWER** switch in the **[OFF]** position to silence the alarm. Fryer will **not** power up even if switch is returned to **[ON]** position until the timer is reset by cleaning.

- ③ **SNOOZE**  
The **SNOOZE** feature is provided for use in the event that **[TIMEOUT]** occurred during a period of high customer demand or while cooking is in progress. When timer has *timed out*, press the **SNOOZE** button to temporarily set it back to **[WARNING]** mode for a period of **2 hours** to allow continued operation.

**Only two (2) SNOOZE periods can be used.** During the second period, the **CHANGE SOON** light will flash to indicate that timer is in the final snooze period. After second period expires, the appliance is locked-out and **cannot** be restarted until the cell is cleaned.

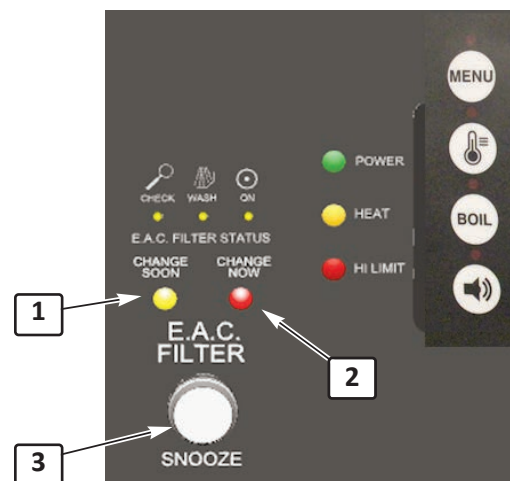

6.1.8 E.A.C. Filter Cell Cleaning

<b>CAUTION</b>	The E.A.C. collector cell contains parts made of thin gauge sheet metal that can potentially have sharp edges, which may cause cut injury if not handled properly. To avoid injury, exercise due care when handling and/or cleaning the cell. <b><i>It is recommended to wear heavy-duty rubber gloves as a precaution.</i></b>
 Sharp edges Watch your fingers	

The E.A.C. collector cell is sustainable and renewable; it should last for years if cleaned and handled properly. To maintain peak performance, it ***MUST BE CLEANED DAILY***; failure to do so can lead to an interruption of appliance operation, premature failure of the electronic air cleaning system, or reduced useful life of the consumable charcoal filters. Follow the procedures detailed below for effective cleaning.

**IMPORTANT:** *The cell CANNOT withstand washing in commercial dishwashing equipment, and some commercial cleaners & detergents will cause oxidation or create a layer of contamination on the aluminum collection fins that can cause malfunction and result in interruption of power to the fryer.*

Two (2) different cleaning methods are endorsed by GILES Food Service, as follows.

- **Preferred:** *Spray foam method* uses **Simple Green® Crystal Foaming Spray Cleaner/Degreaser**. A readily available foaming aerosol that is an exceptionally effective cleaner, as well as being safe for use on aluminum surfaces (*NSF approved, food-grade, non-toxic & biodegradable*). Cleaning the E.A.C. cell is quick and easy with this convenient ready-to-use cleaner. A complimentary sample has been supplied with your new equipment. It can be ordered from Giles, **item #41510 (12-count case)**. When used as directed, a case of cleaner should last approximately 4 to 5 weeks, depending on activity.
- **Alternative:** *Soaking method* uses a diluted solution of **Simple Green® Pro-HD** and water. Although not as convenient as the spray, requiring more planning and time, the procedure has proven to be very satisfactory for cleaning E.A.C. collector cells for many years. This product has the same properties & characteristics of the spray product, but requires mixing with water before use ... **dilution factor is 1:12**, e.g. 1/2 gal. of cleaner per 6 gals. of water.

*With proper care, cleaning, and handling, the E.A.C. collector cell is designed to provide years of service.*

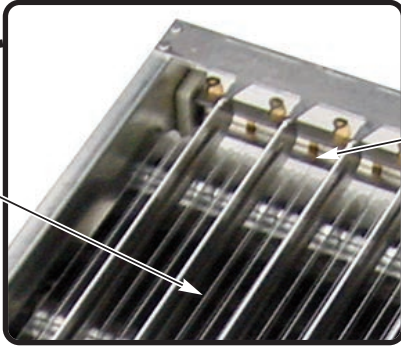
<b>CAUTION</b>	While handling and cleaning the cell, take care not to bend the collection fins or break any of the (9) fine ionizer wires that are stretched across the face of the cell. Bent fins and broken/missing wires can prevent the system from performing properly. System faults and alarms will occur that can potentially interrupt appliance operation.
 Fin	 Ionizer Wire (9) required
<p><b><i>Damage from abusive handling and/or improper maintenance may not be covered by the factory warranty.</i></b></p>	

## 6.1.8 E.A.C. Filter Cell Cleaning - continued

### A. Preferred Cleaning Method - Spray Cleaner

1. Remove collector cell from hood (see **Section 6.1.5**) and lay on a drain board or other suitable surface.
2. Hold the can at an appropriate distance and spray **Simple Green® Crystal Foaming Degreaser** onto the cell, completely covering all surfaces ... collection fins, contact plate, brass fittings and inside corners of frame. Turn cell over and apply cleaner to the other side in like manner, ensuring that both sides of all collector fins are completely covered.
3. Allow foam to soak for **5 to 10 minutes**. In cases of extreme build-up, a second application may be required after rinsing.
4. Carefully move cell to sink and rinse thoroughly, using hot water spray. **Rinse ONLY, DO NOT scrub with brushes.**
5. Stand cell upright on end on a drain board with contact plate up ... allow it to drain and air dry overnight. The cell must be completely dry before being replaced in hood unit. If desired, a small electric fan can be used to blow across the cell to help expedite drying.
6. Before replacing cell in the hood, inspect for broken/missing ionizer wires and bent fins. Broken or missing wires need to be replaced promptly. Bent fins may be straightened by hand so that no fins are touching adjacent fins.

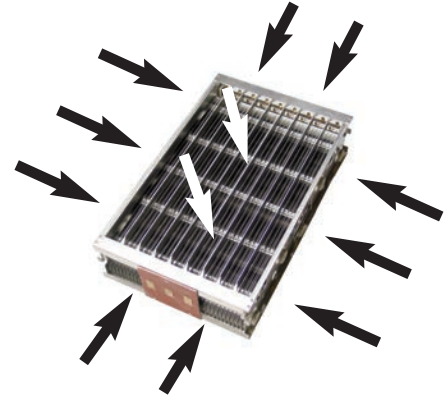

**IMPORTANT! ONLY Simple Green® Crystal Foaming Cleaner/Degreaser is recommended by GILES for cleaning the E.A.C. cell in this manner. Other available spray cleaners can contain corrosive ingredients that may damage the metal components, causing cell to fail or not perform properly. Such damages are not covered by the factory warranty.**

### B. Alternate Cleaning Method - Soaking

The factory-recommended product to use for cleaning the E.A.C. cell in this manner is **Simple Green® Pro-HD**. It is a readily available, biodegradable, non-toxic degreasing cleaner that is safe for use on aluminum. It performs well to clean the cell when diluted at a **1:12 ratio** (e.g. 1/2 gal. cleaner to 6 gals ambient water).

**DO NOT use DISHWASHING DETERGENTS or CORROSIVE CLEANERS as they can contain ingredients that may damage the metal cell components, causing failure or unsatisfactory performance. Such damages are not covered by the factory warranty.**

1. Cleaning with this method requires a suitable, leakproof container, such as a tall trash bin, recycle bin, plastic tote, or the **GILES soak tank\***. that is large enough to hold the cell along with enough degreasing solution to completely cover and soak it, either standing on end, on edge, or lying flat.

\* The **GILES soak tank** (purchased separately, Item# **91123**) is specifically designed & sized for soaking the EAC cell. Use 1/2 gal. of the cleaner & fill to the marked "FULL" line with clean water.



Continued on Next Page

**6.1.8 E.A.C. Filter Cell Cleaning - continued**

2. Fill the container with fresh water to a level that will almost cover the cell. Measure water as filling and note the quantity. Add *Simple Green® Pro-HD* in the **ratio of 1:12** to the water (*e.g. 8 gals of water would require .67 gals (2 qts+21 ozs) degreaser*). Stir solution well to mix.
3. After preparing a quantity of degreaser solution sufficient for cell to be completely submerge in the soaking container, carefully place it into the solution. Be sure that it is fully submerged.
4. Allow cell to soak for approximately **20 minutes (no more than 30 mins)**, then lift it slightly and briefly agitate it in the solution to help dislodge grease residue.
5. Carefully remove cell from container and follow **Steps 4 thru 6** as explained in the previous section.



**NOTE:**  
 The degreasing solution can be used multiple times ... cover container with a lid or other suitable cover when not in use to prevent contamination. Discard and replenish solution when a greasy film remains visible, floating on the surface of the liquid. When soaking, always ensure that solution completely covers the cell ... add water if needed.

**6.1.9 Charcoal Filter Removal & Installation**

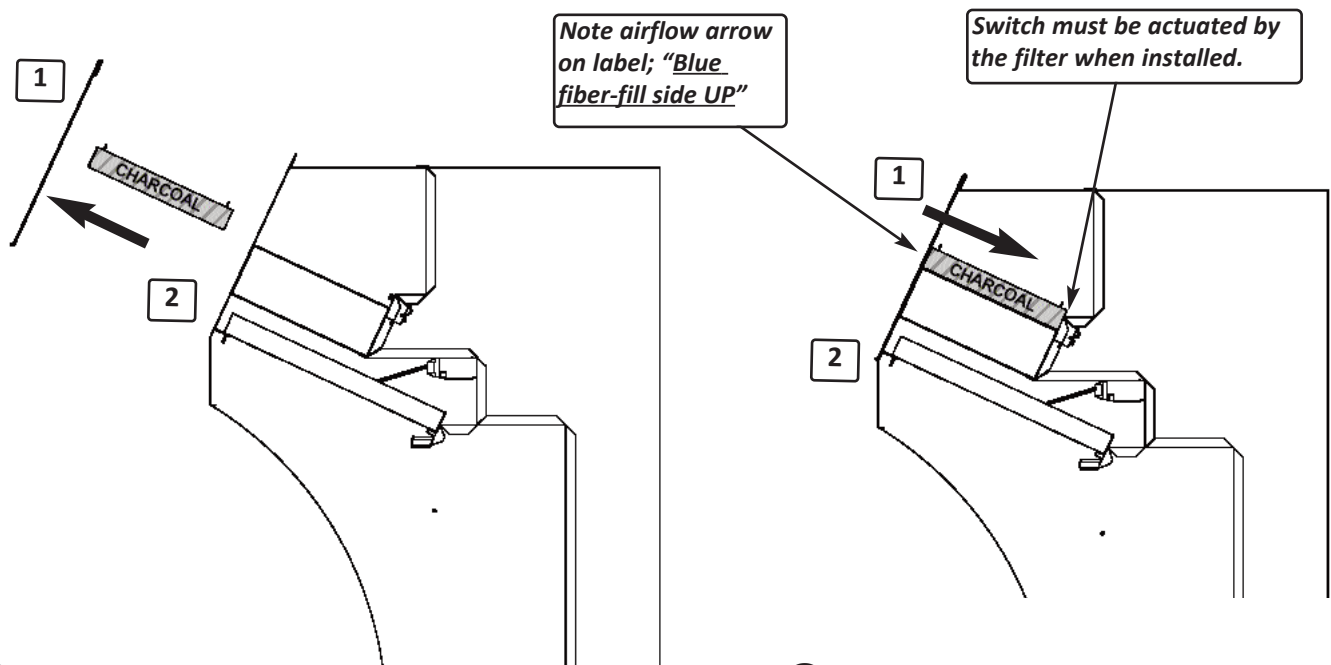

- ① Turn power OFF, unlatch Access Cover and lift off.
- ② Grasp charcoal filter and pull straight out, at an slight upward angle.

- ① Align in guide channels, slide straight into hood. Filter must fit flush with front. **Blue fiber-fill side must face upward.**
- ② Replace and latch cover.

## 6.1.10 Charcoal Filter Maintenance

The charcoal filter cannot be cleaned and reused ... **ONLY REPLACE**. Filter is a one-use consumable that must be **REPLACED** periodically. Never attempt to clean the filter ... damage to the equipment could result.

Typical replacement cycle is approximately **30 to 40 days**, depending on fryer operation hours, types of foods being cooked, and operator diligence with regard to EAC collector cell cleaning.

Replace filter with **Giles Item No. 30248**.

**Failure to use Giles OEM Replacement Parts and Filters may void the factory warranty.**

**IMPORTANT!** Attempting to use a charcoal filter for too long a time can lead to the **CLOGGED FILTER** alarm, see Section 6.1.11, Filter Alarm Chart.

At that time, hood capture performance has fallen below minimum requirements, causing the alarm and fryer heating elements to shutdown until the situation is corrected..

## 6.1.11 Filter Alarm Chart

The following table explains the various possible *filter alarms*. When an alarm condition occurs, an alarm tone sounds, an error code is displayed on the *lower display* and error description is shown on the *upper display*. Refer to **Sections 4.1.10 & 4.1.10.1** for more information.



Error Message [Error Code]	What will happen	Filter Affected	Cause	Solution	See Section
<b>ERROR ALARM - BAFFLE FILTER MISSING [Er21]</b>	<ul style="list-style-type: none"> <li>Continuous tone alarm.</li> <li>Heating element power shutdown.</li> </ul>	Baffle	The filter is not installed, or is mis-aligned.	Install filter. Check filter alignment.	6.1.2 & 6.1.3

6.1.11 Filter Alarm Chart - continued

Error Message [Error Code]	What will happen	Filter Affected	Cause	Solution	See Section
<b>ERROR ALARM - CHARCOAL FILTER MISSING [Er22]</b>	<ul style="list-style-type: none"> <li>• Continuous tone alarm.</li> <li>• Heating element power shutdown.</li> </ul>	Charcoal	The filter is not installed, or is mis-aligned.	Install filter. Check filter alignment.	6.1.9
<b>ERROR ALARM - CLOGGED FILTER [Er23]</b>	<ul style="list-style-type: none"> <li>• Continuous tone alarm.</li> <li>• Heating element power shutdown.</li> </ul>	Charcoal or Baffle	Airflow restriction is present. charcoal or baffle filter clogged. Other possible restrictions.	Replace charcoal filter, about every 30 days. Clean baffle filter. Check for other airflow restrictions.	6.1.4 & 6.1.10
<b>ERROR ALARM - CLEAN THE EAC [Er24]</b>	<ul style="list-style-type: none"> <li>• EAC Status [WASH] light ON</li> <li>• Continuous tone alarm</li> <li>• Power to heating elements is shutdown after 2 mins.</li> </ul>	E.A.C.	Collector cell is dirty. Cell not installed. Contacts dirty. Other fault conditions.	Clean collector cell Install cell correctly.	6.1.7 & 6.1.8

## 6.2 Maintenance

This section describes the periodic maintenance required for the **Ventless Hood System**. These activities are essential to maintaining continuing hood efficiency and safe operation.

*A Maintenance & Service Log is provided on Page 80.*

### 6.2.1 Monthly Interlock Testing

The hood features a system of interlocks which ensure that the unit operates safely and effectively. Inspection and testing of this system should be performed **MONTHLY**, as described below. Check the appropriate box in the **Service Log** to indicate completion of tests. When performing these tests, each time power is turned OFF and then turned ON again, the unit goes through the power-up sequence explained in **Section 4.01.10, Power Up Procedure**

1. **BAFFLE FILTER:** Place **POWER & SELECTOR** switches in the **[OFF]** position, remove the **baffle filter (Section 6.1.2)** and replace cover. Confirm that **SELECTOR** switch is in **[OFF]** position then turn ON power. After power-up, a constant tone alarm should sound, and the *upper display* should read **"ERROR ALARM - BAFFLE FILTER MISSING"**. Place **SELECTOR** switch in the **[COOK]** position ... the amber **HEAT** light should **NOT** turn ON. Return **SELECTOR** switch to **[OFF]**, turn power **OFF**, and reinstall the **baffle filter (Section 6.1.3)**.
2. **E.A.C. FILTER:** Remove the **EAC collector cell (Section 6.1.5)** and replace cover. Confirm that **SELECTOR** switch is in **[OFF]** position then turn ON power. After power-up, the **EAC status [ON] & [WASH]** lights will turn ON. Wait approximately two (2) minutes, a constant tone alarm sounds ... the *upper display* should read **"ERROR ALARM - CLEAN THE EAC"**. Place **SELECTOR** switch in the **[COOK]** position ... the amber **HEAT** light should **NOT** turn ON. Return **SELECTOR** switch to **[OFF]**, turn power **OFF**, and reinstall the **collector cell (Section 6.1.6)**.
3. **CHARCOAL FILTER:** Remove the **charcoal filter (Section 6.1.9)** and replace cover. Confirm that **SELECTOR** switch is in **[OFF]** position then turn ON power. After power-up, a constant tone alarm should sound ... the *upper display* should read **"ERROR ALARM - CHARCOAL FILTER MISSING"**. Place **SELECTOR** switch in the **[COOK]** position ... the amber **HEAT** light should **NOT** turn ON. Return **SELECTOR** switch to **[OFF]**, turn power **OFF**, and reinstall the **charcoal filter (Section 6.1.9)**.
4. **FILTER CLOGGED:** Place the **POWER** switch in the **[ON]**. With hood running, position a piece of filter paper, or other suitable material, such as cardboard, over the **baffle filter** so that the entire area is covered and sealed off. Shortly, a constant tone alarm should sound ... the *upper display* should read **"ERROR ALARM - CLOGGED FILTER"**. Place **SELECTOR** switch in the **[COOK]** position ... the amber **HEAT** light should **NOT** turn ON. Return all switches to the **[OFF]** position and remove the filter blockage.
5. **ACCESS COVER:** Place **POWER** switch in the **[ON]** position. Note the controller powers up and the hood blower starts running. Unlatch and lift front edge of **access cover** away from hood. The appliance should shutdown completely.

Should the equipment fail to react as described to any of these tests, contact a factory-authorized service company and have the unit evaluated and repaired. Any *Giles Manufacturer's Representative* can provide information about nearby service companies, or call **Giles Services** at **800-554-4537** for assistance.

## 6.2.2 Quarterly Ventless Hood Section Cleaning

Disconnect power at the main electrical panel. Remove the *access cover* and *all filters*. Using a degreasing cleaner (*such as recommended for EAC cleaning*), deep clean the entire plenum and blower section of the hood. Recommended cleaning frequency is **every three (3) months**.

Inspect the blower wheel for grease residue build-up on the vanes. Clean with degreaser, if needed.

Ensure that contacts on the **E.A.C. contact board** are clean and free of excessive build-up.

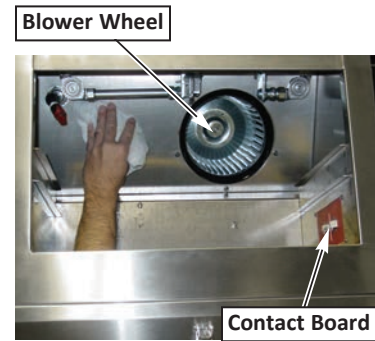

## 6.2.3 Semi-Annual Fire Suppression System Inspection & Service

Inspection, servicing and maintenance of the *fire suppression system* must be performed by a qualified fire protection equipment service company, having credentials acceptable to *local code authorities (AHJ)*. As a minimum, field inspection of the system shall be performed **every six (6) months** and shall consist of the following:

1. Remove and inspect charging cartridge. Replace gasket, if needed. See **Section 2.8. Fusible Link and Gas Cartridge Locations**. **To prevent accidental system discharge, DO NOT replace cartridge until inspection is complete.**
2. Remove and inspect suppressant chemical tank. Verify proper chemical level. Clean and coat o-ring with high-temperature grease, and reinstall. See **Section 2.9. Fire Extinguisher Nozzle and Tank Locations**.
3. Inspect and clean discharge nozzles. Replace missing or damaged *blow-off caps*.
4. Inspect remote *Manual Activation Station* for function and wear.
5. Test automatic actuation function with test link. Replace actual link and re-arm system.
6. Inspect and clean fusible links. See **Section 2.8. Fusible Link and Gas Cartridge Locations**
7. Inspect wire rope for wear at pulleys and detectors ... replace as needed.
8. Replace gas cartridge, tag system and confirm that it is armed. Record maintenance date and log the inspection in permanent on-site file.

## 6.2.4 Annual Fire Suppression System Inspection & Service

Same as *Semi-Annual* Inspection, **except** for the following:

1. Replace all fusible links. See **Section 2-08. Fusible Link and Gas Cartridge Locations**.

## 6.2.5 12-Year Fire Suppression System Inspection & Service

Same as *Semi-Annual* and *Annual* Inspection, **except** for the following:

1. Remove suppressant chemical from tank. Hydrostatic test storage tank and gas cartridge.
2. Refill storage tank with fresh **R-102 wet chemical fire suppressant**.
3. Flow test the regulator.



## 7. Troubleshooting

**IMPORTANT!** This section describes basic troubleshooting procedures for GEF Model Electric Fryers. Simple operational issues may be corrected by the user, however most in-depth troubleshooting, and repair, should be performed only by qualified service technicians.

7.1 Temperature Control System		
Problem	Probable Cause	Corrective Action
<b>APPLIANCE WILL NOT TURN ON:</b> • <b>POWER</b> light OFF • VH Model - Hood fan not ON  <i>**Fuses on 480V models are located on the step-down transformer inside the rear cabinet panel.</i>	A. Not connected to proper power source	Connect unit to proper power supply
	B. Blown fuse or tripped breaker in electrical supply panel	Check electrical panel, replace fuse or reset breaker
	C. <b>**Blown fuse in unit or faulty fuse holder</b>	<b>**Check/replace fuses and/or fuse holders ... behind small access cover on service entry box.</b>
	D. <b>(VH Model)</b> Hood filter cover not positioned & latched properly	Position cover properly; pin on right corner must engage interlock switch
	E. Faulty power switch	Check/replace power switch
	F. Fire suppression system not armed	Contact Ansul service company
	G. <b>(VH Model)</b> EAC Cleaning Timer has expired; red <b>CHANGE NOW</b> light is ON	Clean EAC cell, or press <b>SNOOZE</b> button to continue operation for 2 hours
<b>FRYER DOES NOT HEAT:</b> • <b>POWER</b> light ON • Amber <b>HEAT</b> light OFF	A. SELECTOR switch not in the <b>[COOK]</b> position	Place SELECTOR switch in <b>[COOK]</b> position
<b>FRYER DOES NOT HEAT:</b> • <b>POWER</b> light ON • SELECTOR switch is in <b>[COOK]</b> position • Amber <b>HEAT</b> light OFF	A. Actual oil temp higher than controller setpoint	Reset the temperature or if actual temp is correct, begin cooking
	B. <b>DRAIN OPEN</b> message ... alarm sounding	Close valve fully to reset alarm
	C. Faulty controller	Check/replace Controller
	D. Temperature sensor faulty; Er13 displayed	Check wiring; replace sensor
	F. Contactor is faulty	Check/replace Contactor
	G. SELECTOR switch faulty	Check/replace Switch
	I. Power-up procedure not completed	At <b>POWER FAILURE</b> msg, press <b>[START]</b> key to begin <b>PREHEAT</b>
<b>FRYER WILL NOT HEAT (certain models):</b> • <b>POWER</b> light ON • SELECTOR switch in <b>[COOK]</b> position • Amber <b>HEAT</b> light ON	A. Circuit breaker on rear of fryer cabinet tripped	Reset circuit breaker

7.1 Temperature Control System - continued		
Problem	Probable Cause	Corrective Action
<b>FRYER WILL NOT HEAT:</b> <i>(VH Model Only)</i> <ul style="list-style-type: none"> <li>• <b>POWER</b> light ON</li> <li>• <b>SELECTOR</b> switch in <b>[COOK]</b> position</li> <li>• <b>HEAT</b> light OFF</li> <li>• Steady tone alarm sounding</li> <li>• <b>“MISSING FILTER”</b> message displayed on controller</li> </ul>	A. Baffle filter missing	Check, install baffle filter
	B. Baffle filter misaligned	Check, reinstall, or properly align baffle filter
	C. Charcoal filter missing or misaligned	Check, reinstall, or properly align charcoal filter
<b>FRYER WILL NOT HEAT:</b> <i>(VH Model Only)</i> <ul style="list-style-type: none"> <li>• <b>POWER</b> light ON</li> <li>• <b>SELECTOR</b> switch in <b>[COOK]</b> position</li> <li>• <b>HEAT</b> light OFF</li> <li>• <b>EAC [WASH]</b> light ON</li> <li>• Steady tone alarm sounding</li> <li>• <b>“CLEAN THE EAC”</b> message displayed on controller</li> </ul>	A. EAC cell is excessively dirty	Clean the cell as described
	B. Too many ionizer wires on the cell are broken/missing	Replace ionizer wires
	C. Poor connection at contact board; dirty or damaged	Clean contacts, or replace board
	D. EAC cell is missing	Install or reinstall EAC Cell
<b>NORMAL FRYER OPERATION:</b> <i>(VH Model Only)</i> <ul style="list-style-type: none"> <li>• <b>POWER</b> light ON</li> <li>• <b>SELECTOR</b> switch in <b>[COOK]</b> position</li> <li>• <b>EAC [CHECK]</b> light staying ON</li> <li>• No alarm</li> </ul>	A. Ionizer wire broken ... touching cell frame.	Replace wire
	B. Cell damaged ... shorted to ground	Inspect cell, replace if needed
	C. Collection fin shorted out due to excessive moisture	Eliminate cause ... cold air from a/c being drawn into hood, excessive moisture in food, etc.
<b>FRYER WILL NOT HEAT:</b> <ul style="list-style-type: none"> <li>• <b>POWER</b> light ON</li> <li>• <b>SELECTOR</b> switch in <b>[COOK]</b> position</li> <li>• Red <b>HILIMIT</b> light ON</li> </ul>	A. Power surge tripped thermostat	Turn OFF power for approx 5 secs, return to ON
	B. Low oil level	Check level, add oil as needed
	C. Contactor is sticking	Check/replace Contactor
	D. High Limit safety board is faulty	Check/replace High Limit board
	E. High Limit sensor is faulty, or out of position	Check, adjust, or replace sensor
	E. Controller is faulty	Check/replace Controller
<b>FRYER WILL NOT HEAT:</b> <i>(VH Model Only)</i> <ul style="list-style-type: none"> <li>• <b>POWER</b> light ON</li> <li>• <b>SELECTOR</b> switch in <b>[COOK]</b> position</li> <li>• <b>HEAT</b> light OFF</li> <li>• Constant tone alarm sounding</li> <li>• <b>“CLOGGED FILTER”</b> message displayed on controller</li> </ul>	A. Charcoal filter clogged	Replace charcoal filter
	B. Vacuum switch requires adjustment, or is faulty	Adjust switch, replace if needed
	C. Vacuum lines clogged or kinked	Inspect tubing clean or remove kinks
	D. Blower running too slow	Check voltage
	E. Blower vanes clogged w/residue	Inspect blower, clean

7.1 Temperature Control System - continued		
Problem	Probable Cause	Corrective Action
<b>FRYER HEATS SLOWLY:</b> • Slow heat recovery • <b>HEAT</b> light ON constantly	A. Improper cooking procedures	Consult Manual for proper procedures
	B. One or more heating elements faulty	Check/replace faulty element(s)
	C. Contactor failing	Check/replace Contactor
	D. Wiring at elements loose	Inspect/repair wiring
	E. Low incoming supply voltage	Check/repair supply power
<b>FRYER HEATS SLOWLY</b> • Short cycling, <b>HEAT</b> light turning <b>ON &amp; OFF continuously</b>	A. Low incoming supply voltage	Check/repair supply power
	B. Variable temp sensor too close to heating element	Correct sensor position
	C. Controller malfunctioning	Replace controller
<b>OIL TEMPERATURE ERRATIC:</b>	A. Faulty temperature sensor	Replace probe
	B. Contactor is failing	Replace contactor
	C. Controller malfunctioning	Replace Controller
	D. Wiring at elements loose	Inspect/repair wiring
<b>OIL SMOKING:</b>	A. Oil too old ... broken down	Replace with fresh oil
	B. Cooking temperature too high	Check temperature setpoint, adjust
	C. Carbon build-up on heating elements	Perform boil-out, clean the fry pot
	D. Element failure	Check/replace elements
	E. Improper incoming supply voltage	Verify incoming power
	F. Low oil level	Maintain oil level at <b>[FULL]</b> level mark

7.2 Oil Filtration System		
Problem	Probable Cause	Corrective Action
<b>OIL NOT PUMPING BACK FROM FILTER PAN TO FRY POT:</b>	A. SELECTOR switch not in [ <b>FILTER PUMP</b> ] position	Place switch in proper position
	B. Air leak in the system ... hoses, fittings, connectors, or filter pan	Inspect & stop air leak ... be sure quick-couple fitting is secure
	C. Pump motor faulty	Check/replace Motor
	D. Oil pump clogged or damaged	Check/repair Pump
	E. Excessive sludge in filter pan	Clean filter pan ... replace media
<b>OIL PUMP LOCKED UP</b>	A. Boil-out solution has been run through filter pump	Disassemble pump head, clean & re-oil
	B. Oil allowed to setup inside pump	Disassemble pump head & clean

7.3 Basket Lift System		
Problem	Probable Cause	Corrective Action
<b>BASKET LIFT DOES NOT FUNCTION:</b>	A. Power not ON	Place POWER switch in [ <b>ON</b> ] position
	B. Controller malfunction	Check/replace controller
	C. Cooking cycle in progress	Cancel cycle or wait for completion
	D. Basket lift micro-switch out of adjustment	Inspect/adjust switch
	E. Basket lift micro-switch faulty	Check/replace switch
	F. Basket lift motor/gearbox faulty	Check/replace lift motor
	G. Controller still in <b>PREHEAT</b> state, oil is not at <b>READY</b> temperature.	Allow oil to reach cooking temperature
	H. Basket has just finished a cycle	When activated, lift <b>will not</b> activate again for about 20 secs



## 8. Parts List

This section shows the various parts that are, typically, field replaceable on **GEF & GEF-VH Electric Fryers**. It is provided to aid qualified service persons who are servicing or repairing the equipment. Repairs should only be attempted by trained kitchen equipment service persons.

### 8.1 Parts Ordering & Service Information

Giles is an equipment manufacturer and does not sell parts direct. Parts for our equipment are available through authorized service companies, part distributors, and/or kitchen equipment dealers. If assistance with sourcing parts or equipment repair service is required, please contact a *GILES* manufacturer’s representative to help you with locating a parts source or authorized service provider near you.

For further assistance you may contact **GILES Services Support** as follows:

**IN THE UNITED STATES & CANADA call: 800.554.4537**  
**ALL OTHERS call: 334.272.1457**  
 Normal business hours are **8:00 AM to 5:00 PM Central Time** ... calls received are handled by an automated phone attendant system. Please follow the recorded instructions.  
  
 If calling outside of normal hours, leave a voicemail message along with your contact number and a *Services representative* will promptly return your call, usually within thirty (30) minutes.

Website: [www.gfse.com](http://www.gfse.com) or e-mail [services@gfse.com](mailto:services@gfse.com).

Our goal at Giles is to provide the highest possible quality of service and assistance. To help us accomplish this, please have the following information readily available when calling, along with a brief description of the problem being experienced. Please record the unit information in the table below for quick reference.

<b>Model:</b>	
<b>Serial Number:</b>	
<b>Voltage:</b>	
<b>Phase:</b>	

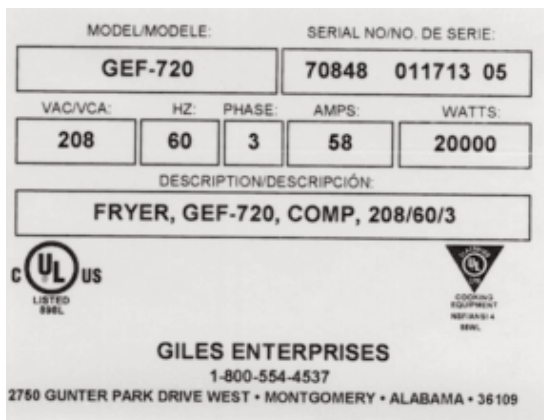

The information can be found on the serial/data label located inside the fryer cabinet or on the cabinet rear panel.

8.2 Control Panel & Front Header

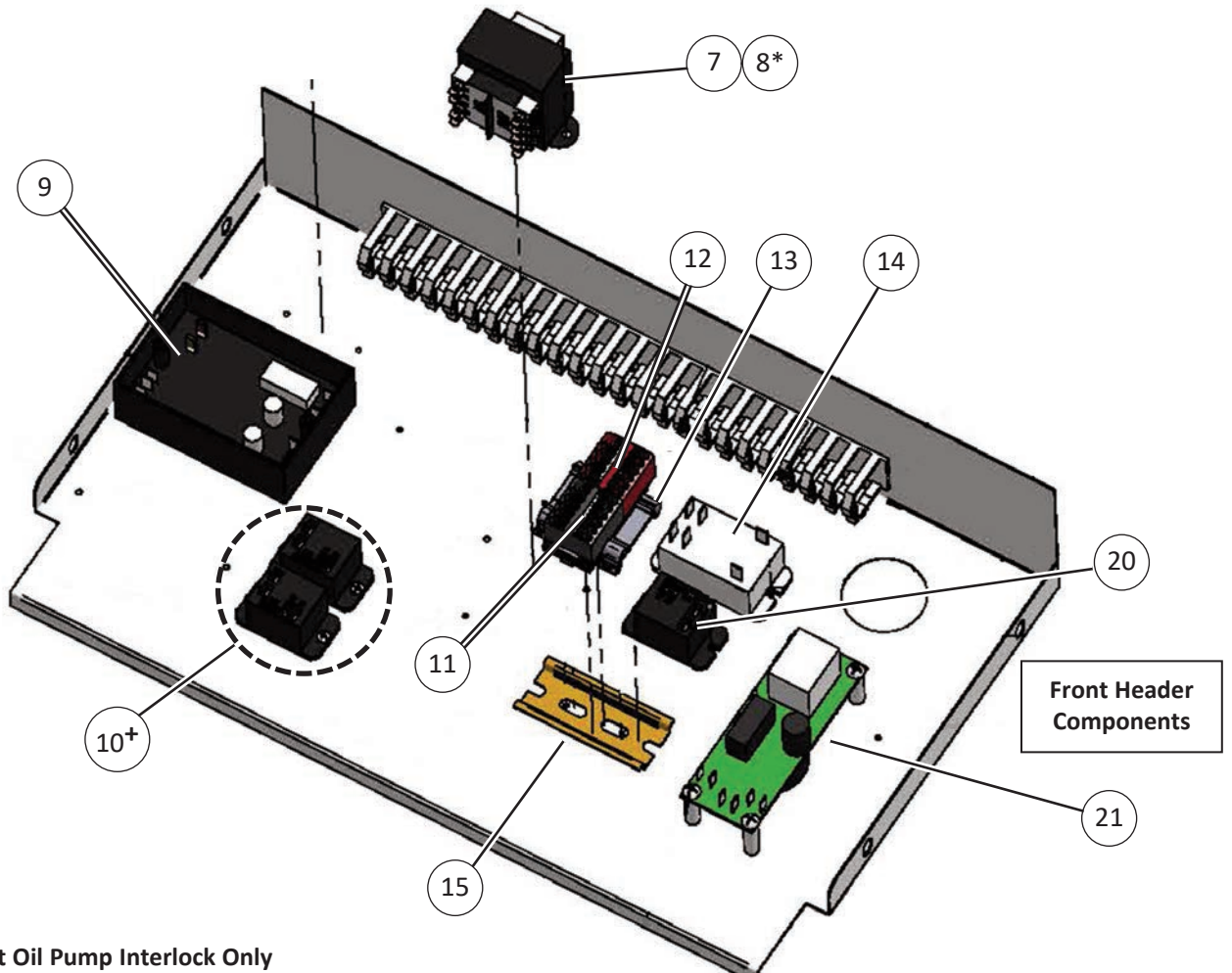

\* Not Shown

+ Units w/Hot Oil Pump Interlock Only

# Parts List

## GEF & GEF-VH Fryers

### 8.2 Control Panel & Front Header

#### Regular GEF Model Fryer:

Item	Part Number	QTY.	Description
1	21374	1	CONTROLLER, SINGLE TIMER, CC10
2	21189	1	SWITCH, ROCKER, ON-OFF-ON, 250V,20A,S.P.
3	21190	1	SWITCH, ROCKER, ON-OFF, 250V, 20A, D.P.
4	21678	1	INDICATOR LIGHT, GREEN, 125-250V
5	21674	1	INDICATOR LIGHT, AMBER, 125-250V
6	21673	1	INDICATOR LIGHT, RED, 125-250V
7	20366	1	TRANSFORMER, 20VA, 115/230V, 60HZ, CL2
8*	38365 91759	1	FUSE ASSY, CONTROLLER TRANSFORMER ( <i>WABASH</i> ) " " " " ( <i>HAMMOND</i> )
9	23754	1	THERMOSTAT, HILIMIT, WATLOW, 425DEG, 208/240
10 <sup>+</sup>	21203	2	RELAY, SPST-NO, 240V ( <i>HOT OIL PUMP INTERLOCK ONLY</i> )
11	21510	1	DISTRIBUTION BLOCK, 12-PL, 12-26 AWG, BLACK
12	21509	1	DISTRIBUTION BLOCK, 12-PL, 12-26 AWG, RED
13	21496	2	CLIP, DIN RAIL, END BRACKET, PTFIX, NS-35
14	21417	1	RELAY, POWER SWITCH, 30A/2.5HP, 240V
15	94784	1	DIN RAIL, 3"

#### Ventless GEF-VH Model Fryer Only:

Item	Part Number	QTY.	Description
16	24209	1	L.E.D. CLUSTER, E.A.C.
17	20694	1	PILOT LIGHT, YELLOW, EAC TIMER
18	20693	1	PILOT LIGHT, RED, EAC TIMER
19	20692	1	SWITCH, MOMENTARY, PUSH-BUTTON
20	21203	1	RELAY, SPST-NO, 240V
21	20572	1	EAC TIMER, BOARD W/LIGHTS & P.BUTTON
22	30238	1	MANUAL PULL, MODIFIED

\* Not Shown

8.3 Front Lower Cabinet

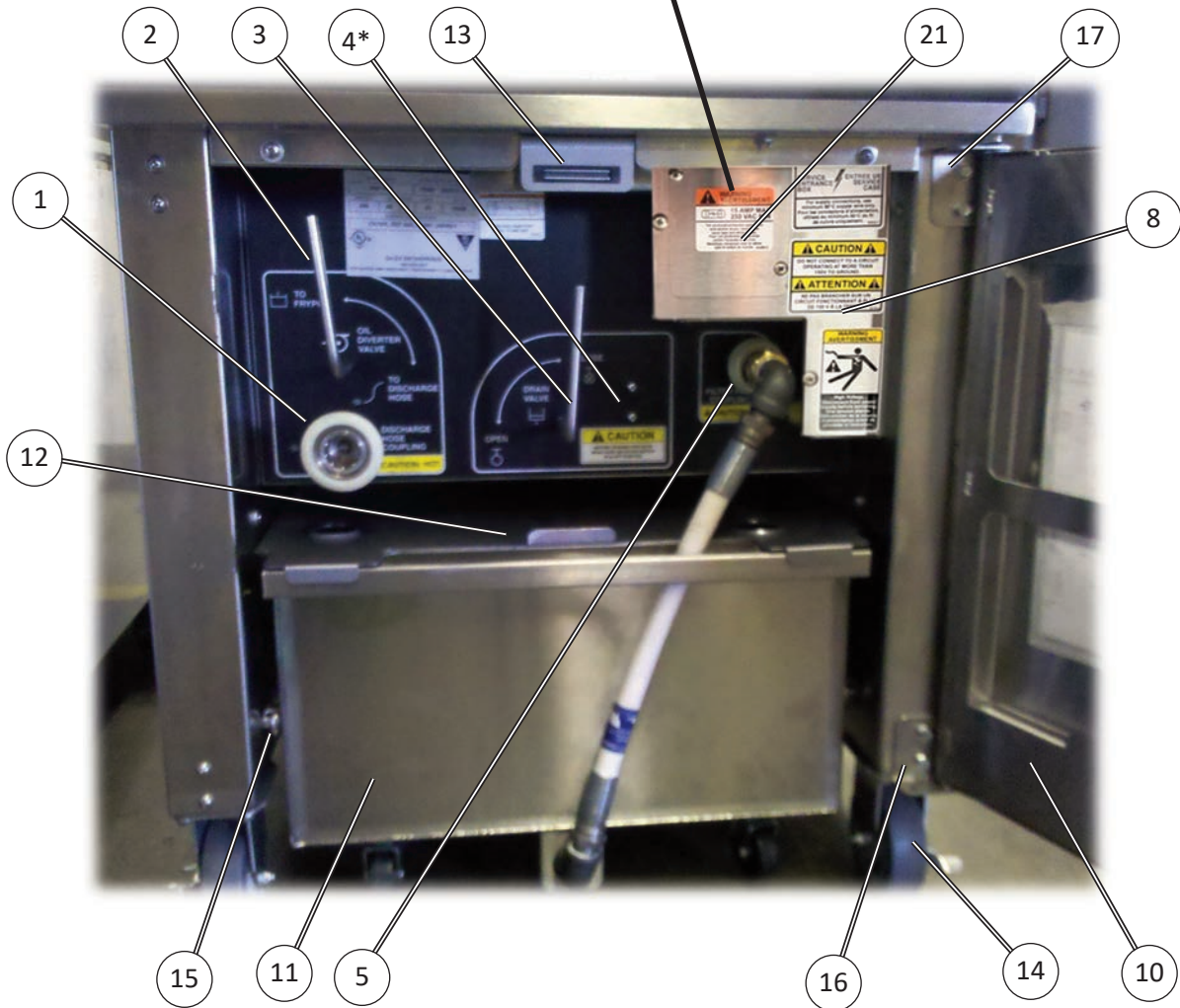
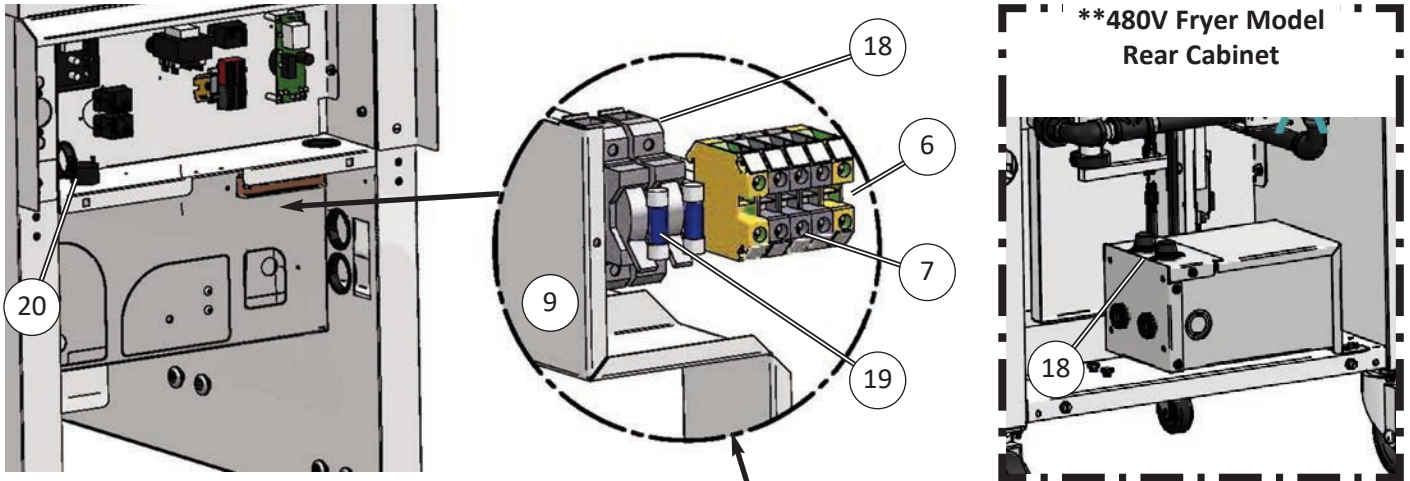

\* Not shown

## 8.3 Front Lower Cabinet

Item	Part Number	Qty	Description
1	41699	1	COUPLING, QUICK DISCONNECT, FEMALE
2	38888	1	DIVERter VALVE HANDLE
3	96688	1	DRAIN VALVE HANDLE
4*	21386	2	SWITCH, LIMIT, SPDT, DRAIN, PREWIRED <b>(BEHIND PANEL)</b>
5	41900	1	COUPLING, QUICK-DISCONNECT, FEMALE
6	20304	2	TERMINAL BLOCK, GROUND, 4-12 GA WIRE
7	20303	3	TERMINAL BLOCK, 4-12 GA WIRE
8	38881	1	COVER, SERVICE BOX
9	38880	1	SHROUD, SERVICE BOX
10	38845	1	DOOR, WELD ASSY, GEF-400/560/720
11	38834	1	FILTER PAN, ASSY, GEF-400/560/720
12	93003	1	FILTER PAN COVER, WELD ASSY, UNIVERSAL
13	40851	1	CATCH, MAGNET, DOOR, SNAP IN, 2.3IN
14	40806	2	CASTER, 5-IN, RIGID, W/BRAKE, PLT. MT.
15	40315	8	ROLLER, BALL-BEARING, FILTER PAN DOCKING
16	90988	1	DOOR HINGE, RIGHT PIN
17	90989	1	DOOR HINGE, LEFT PIN
18	20411	2	FUSE HOLDER, DIN RAIL, 600V, 35A
	**21950	2	FUSE HOLDER, 600V, 15A <b>(see **480V Model inset)</b>
19	21900	2	FUSE, 15-AMP, BUSS, SC-15
20	22976	1	SONALERT, CONTINUOUS, 2-12 VDC
21	99409	1	ACCESS COVER, FUSES, SERVICE BOX

**\*\*NOTE: 480V Model (see inset)**

*Item #18, 21950 Fuse Holders on 480V GEF model fryers differ from other models and are installed on the 480V to 240V step-down transformer which is located inside the rear cabinet panel, mounted onto the lower brace.*

\* Not shown

8.4 Fry Pot

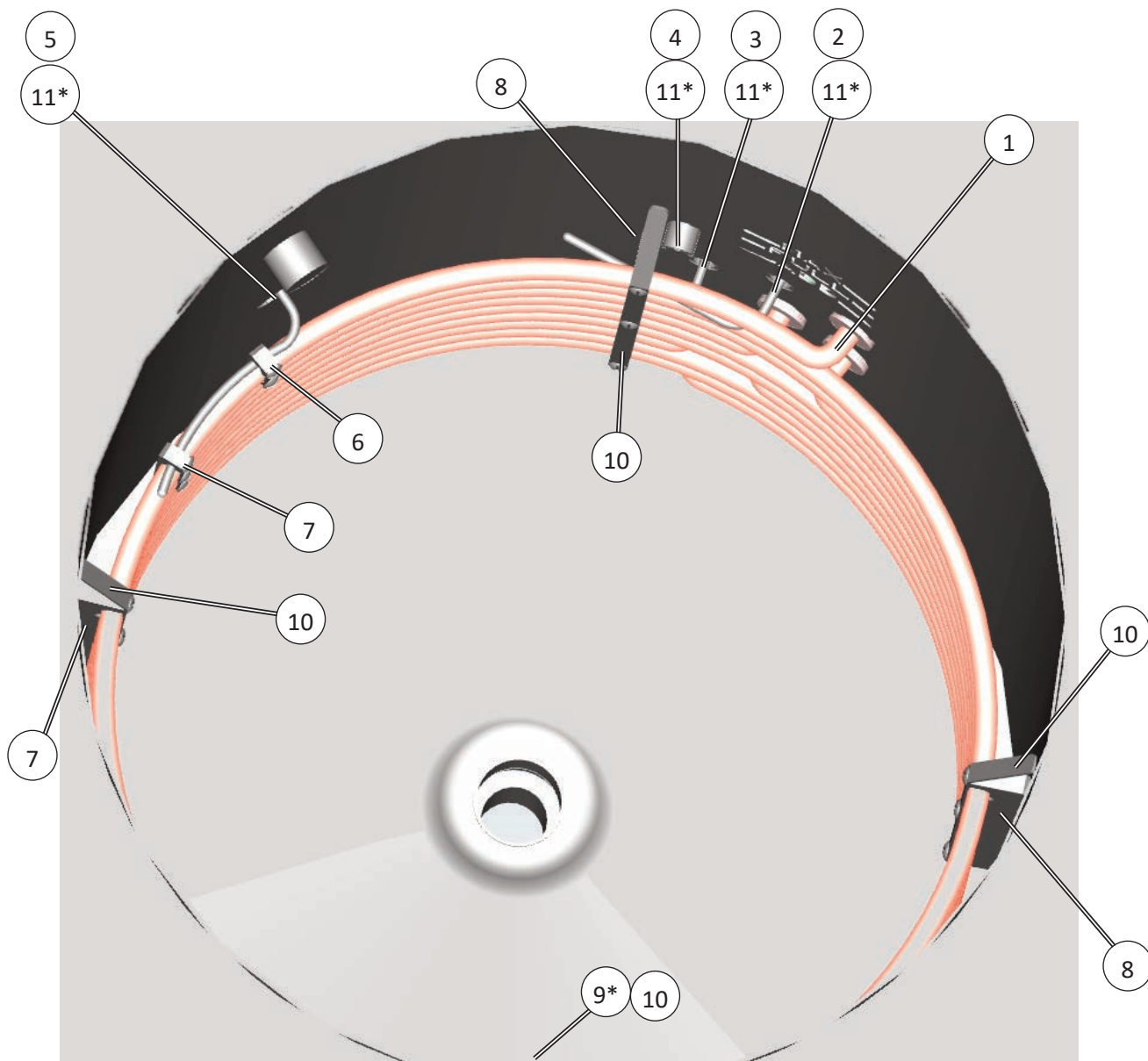

\* Not shown

## 8.4 Fry Pot

Item	Part Number	Qty.	Description
1	20306	3	ELEMENT, 6666W, 208V, <b>GEF-720</b>
	20309	3	ELEMENT, 6666W, 240V, <b>GEF-720</b>
	20313	3	ELEMENT, 6666W, 480V, <b>GEF-720</b>
	21526	3	ELEMENT, ROUND, 5000W, 208V, <b>GEF-560</b>
	21299	3	ELEMENT, ROUND, 5000W, 240V, <b>GEF-560</b>
	21527	3	ELEMENT, ROUND,3333W,208V, <b>GEF-400</b>
	21298	3	ELEMENT, ROUND,3333W,240V, <b>GEF-400</b>
2	23908	1	THERMOCOUPLE, TYPE-J, 7-1/2" BENT, GROUNDED (HI-LIMIT)
3	23909	1	THERMOCOUPLE, TYPE-J, 3", GROUNDED (VARIABLE)
4	20439	1	THERMOCOUPLE, TYPE-J, 3", UNGROUNDED (ADD-LEVEL)
5	20571	1	THERMOCOUPLE, TYPE-J, 7-1/2", UNGROUNDED (ELEM TEMP)
6	96481	1	ELEMENT PROBE BRACKET, SINGLE
7	96475	1	ELEMENT PROBE BRACKET, DOUBLE
8	38894	3	BRACKET, ELEMENT, W/HOLE, GEF-720
	33437	3	BRACKET, ELEMENT, W/HOLE, GEF-560/400
9*	38895	1	BRACKET, ELEMENT, LONG, GEF-720
	33355	1	BRACKET, ELEMENT, LONG, GEF-560/400
10	38896	4	CAP, ELEMENT BRACKET, GEF-720
	33354	4	CAP, ELEMENT BRACKET, GEF-400/560
11*	45400	4	CONNECTOR, 0.190 ID, 1/4NPT, SWAGELOCK ( <i>INCLS. #45111 FERRULE</i> )

**IMPORTANT!**

When replacing Thermocouple Probes (#2, #3, #4, or #5) without replacing the associated Swagelock Connector, a new **Ferrule #45111** is required.

\* Not shown

8.5 Rear Lower Cabinet

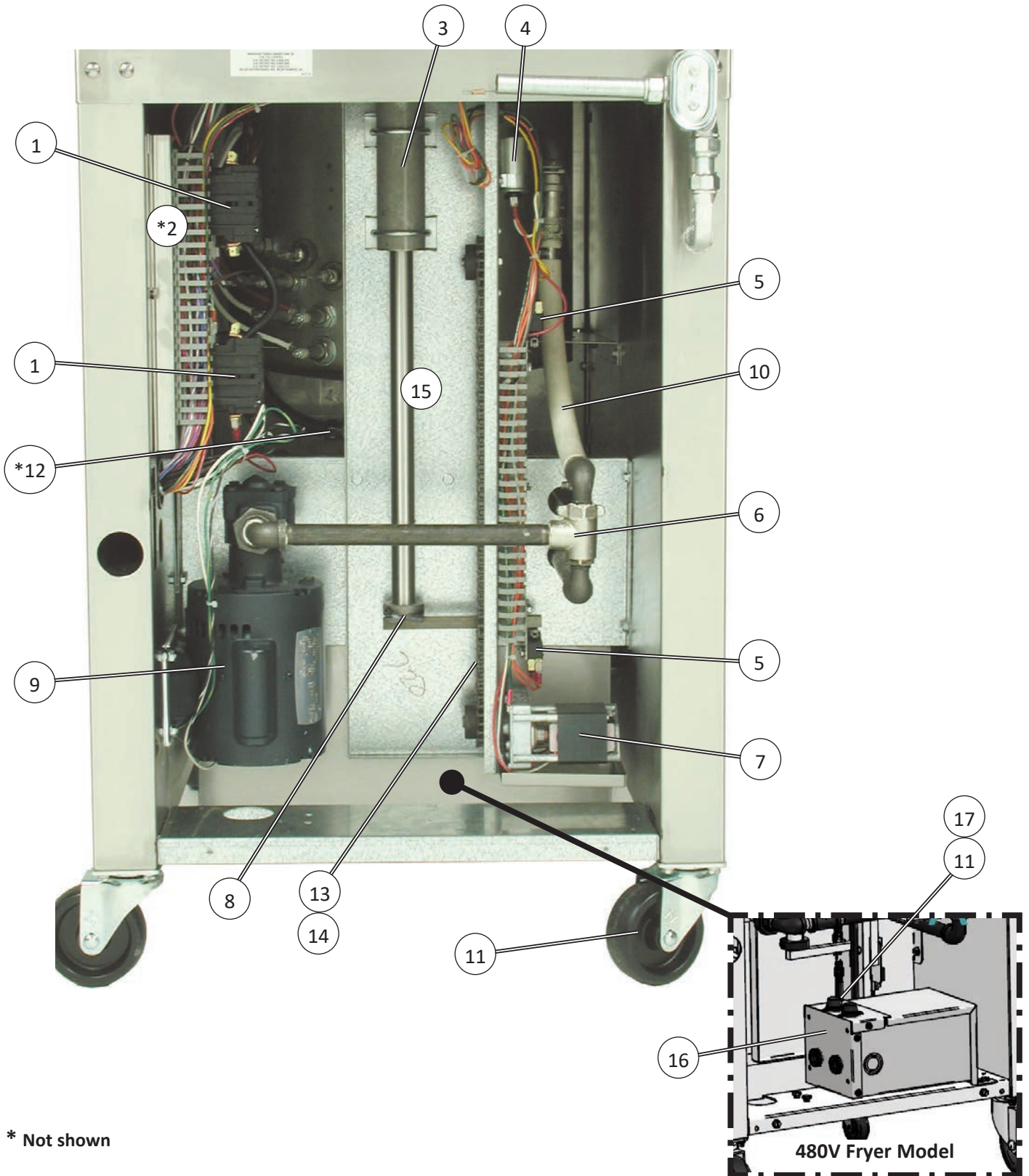

\* Not shown

Due to continuing equipment improvements, some actual components may appear different than depicted in this Manual.

## 8.5 Rear Lower Cabinet

Item	Part Number	Qty.	Description
1	21245	2	CONTACTOR, 208VAC, 63A (GEF400/1-PH, GEF400-560-720/3-PH))
	20617	2	CONTACTOR, 240/480VAC, 63A (GEF400/1-PH, GEF400-560-720/3-PH)
	21260	2	CONTACTOR, 208VAC, 80A (GEF-560)
	21261	2	CONTACTOR, 240VAC, 80A (GEF-560)
2*	20513	1	BREAKER, CIRCUIT, 277V, 50A, 6 PL (1-PH units & 208/240V GEF720)
3	40770	1	SHAFT & CYLINDER ASSY, BASKET LIFT
4	20122	1	CAPACITOR, 4mfd,370V,GEF
5	23201	2	SWITCH, SNAP ACTION, ROLLER TYPE
6	45755	1	VALVE, 3-WAY, 1/2NPT, NICKEL PLATED
7	20120	1	MOTOR, 230V, ELEVATOR,GEF
8	38824	1	ELEVATOR CARRIER, WELD ASSY, GEF
9	71754	1	PUMP & MOTOR ASSY (76923 Pump Head Only, 71753 Motor Only)
10	41080	1	HOSE, CORRUGATED, SS, 1/2 ID X 20"
11	40807	2	CASTER, 5-IN, SWIVEL, W/O BRAKE, PLT. MT.
12*	45876	1	VALVE, 1-1/2 NPT, DRAIN,
13	38829	1	CHAIN, ELEVATOR, S35, 115-PITCH
14	40951	1	MASTERLINK, #35, SINGLE ROW, 3/8 PITCH
15	38827	1	COMPLETE BASKET LIFT ASSEMBLY
16	24277	1	TRANSFORMER, 480V-240V, 1.5 kVA (480V units only)
17	21950	2	FUSE HOLDER, 600V, 15A (480V units only)
18	21900	2	FUSE, 15-AMP, BUSS, SC-15 (480V units only)

\* Not shown

8.6 Basket Cover & Basket

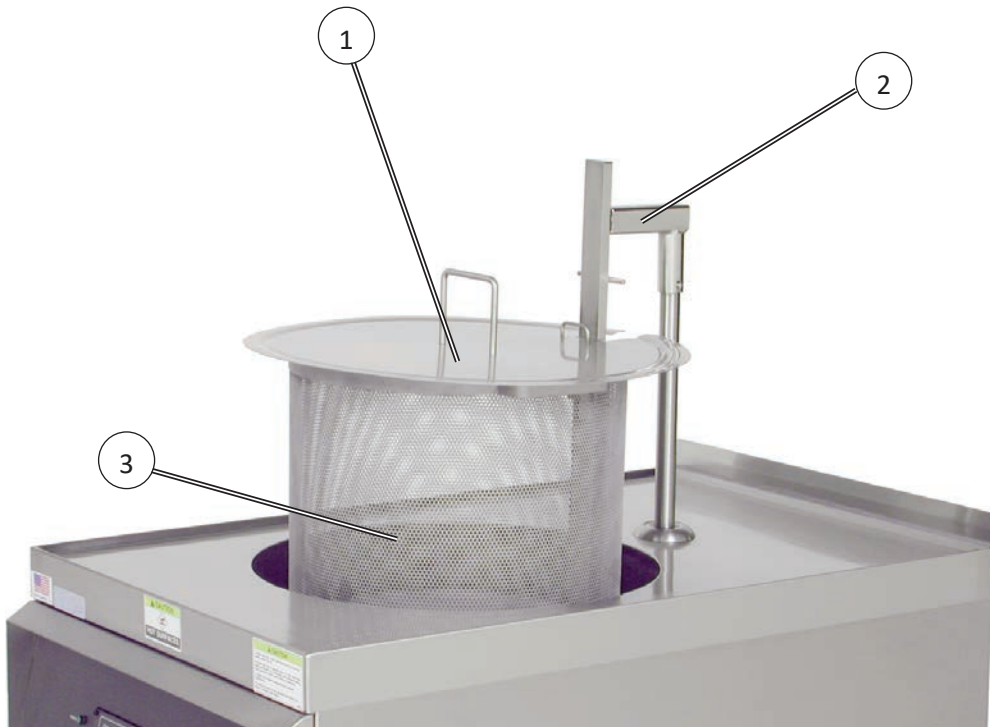

Due to continuing equipment improvements, some actual components may appear different than depicted in this Manual.

## 8.6 Basket Cover & Basket

Item	Part Number	Qty.	Description
1	<a href="#">33883</a>	1	BASKET COVER, ASSY, GEF560/GEF720
	<a href="#">33884</a>	1	BASKET COVER, ASSY, GEF400
2	<a href="#">38930</a>	1	BASKET CARRIER, ASSY, GEF-720
	<a href="#">97132</a>	1	BASKET CARRIER, ASSY, GEF-560
	<a href="#">39165</a>	1	BASKET CARRIER, ASSY, GEF-400
3	<a href="#">91811</a>	1	BASKET, GEF-720
	<a href="#">33703</a>	1	BASKET, GEF-560
	<a href="#">33718</a>	1	BASKET, GEF-400

8.7 Filter Pan Assembly

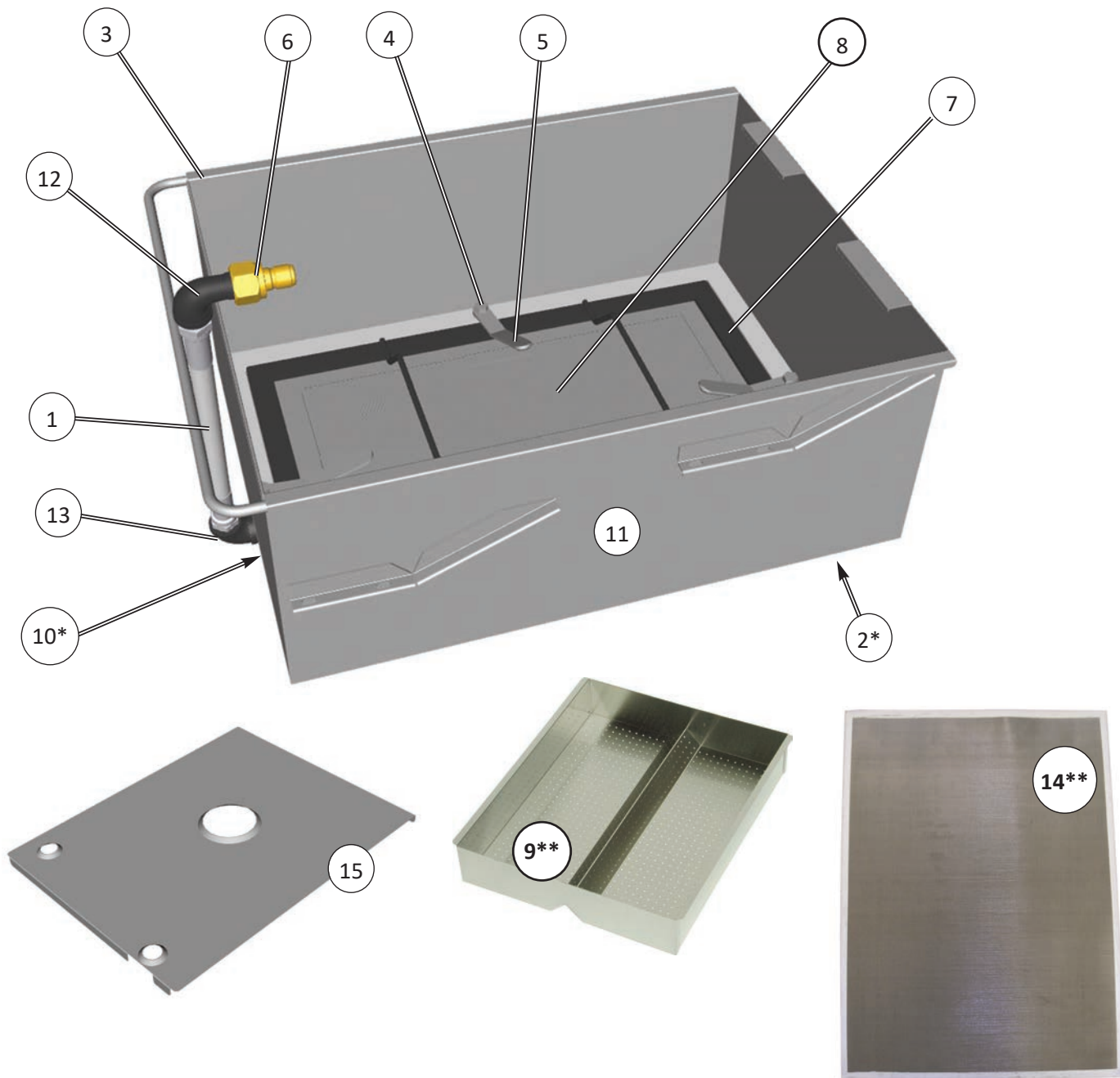

\* Not shown

\*\* Optional item, not included as standard

## 8.7 Filter Pan Assembly

Item	Part Number	Qty.	Description
1	40955	1	HOSE, 1/2NPT X 15.75
2*	40649	4	CASTER, SWIVEL, 2-9/16, FILTER PAN
3	38842	1	FILTER PAN WELD ASSEMBLY <b>(NOT COMPLETE, PAN ONLY)</b>
4	30040-4	4	STUD, FILTER PAN HOLD DOWN FRAME
5	38841	4	HANDLE, SUPPORT FRAME, FILTER PAN
6	44150	1	FITTING, BRASS,MALE,1/2NPT,QUICK DISCONNECT
7	38830	1	HOLD DOWN FRAME, WELD ASSEMBLY
8	60810	1	PAPER, FILTER MEDIA, 21.375 X 15.500 <b>(Sold as 100 ct Case)</b>
9**	39246	1	CRUMB SCREEN, FILTER PAN <b>(NOT INCLUDED, Purchased Separately)</b>
10*	40956	1	HOSE, 1/2NPT X 11.500 (underside of pan)
11	38834	1	COMPLETE FILTER PAN ASSEMBLY <b>(W/O CRUMB SCREEN)</b>
12	42250	1	ELL, 90-DEG, STREET, 1/2-NPT, BLACK PIPE
13	42200	1	ELL, 90-DEG, 1/2-NPT, BLACK PIPE
14**	41014	1	MESH FILTER SCREEN MEDIA, 15-3/8 X 21-1/4 <b>(OPTIONAL)</b>
15	95555	1	FILTER PAN COVER

\* Not shown

\*\* Optional item, not included as standard

8.8 Front Ventless Hood (GEF-VH Only)



\* Not shown

## 8.8 Front Ventless Hood (GEF-VH Only)

Item	Part Number	Qty.	Description
1	90254	1	FILTER ACCESS PANEL, ASSY
2	30248	1	CHARCOAL, FILTER ASSY
3	20520	1	FILTER, EAC, 20 IN
4	42300	1	FILTER, BAFFLE, 20 X 20 X 2, SS
5*	23200	1	SWITCH, SNAP ACTION, ROLLER TYPE
6*	21125	1	BOARD, CONTACT, EAC, VH UNITS
7	30206	1	DRIP CUP, WELD ASSY
8	34750	1	PIN, DRIP CUP SAFETY

\* Not shown

8.9 Rear Ventless Hood (GEF-VH Only)

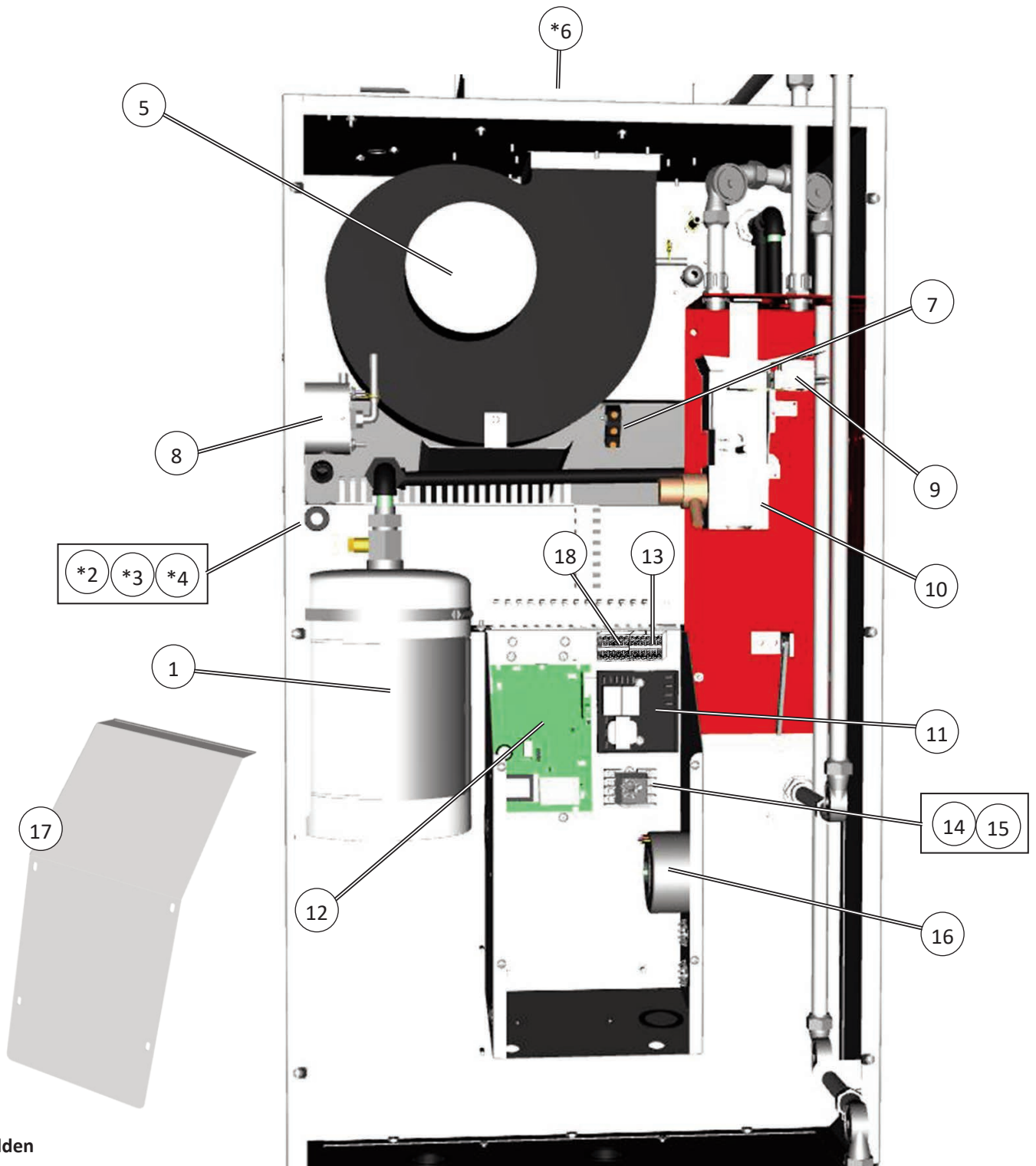

\* Hidden

Due to continuing equipment improvements, some actual components may differ slightly from illustrations in this Manual.

## 8.9 Rear Ventless Hood (GEF-VH Only)

Item	Part Number	Qty.	Description
1	39272	1	TANK, ANSUL, 1.5-GAL SS
2*	<a href="#">23778</a>	1	SWITCH, SIDE ROTARY, 240V, 30A, W/O ARM
3*	<a href="#">23779</a>	1	ROD, ADJUSTMENT
4*	90054	1	ACTUATOR ARM, SWITCH, BAFFLE FILTER
5	<a href="#">33589</a>	1	BLOWER, ASSY, VH-FRYERS
6	<a href="#">46125</a>	1	DAMPER, FIRE, 10 X 10, 285 DEG LINK
7	<a href="#">24237</a>	1	SWITCH, PLUNGER, 250V, 15A
8	<a href="#">20390</a>	1	SWITCH, VACUUM, ADJUSTABLE
9	<a href="#">20002</a>	1	SWITCH, ANSUL, SHUTDOWN/ALARM, 15A, 120V
10	40132	1	BRACKET & RELEASE, ANSUL, AUTOMAN
11	<a href="#">23776</a>	1	MODULE, AIR FILTER, ALARM & SHUTDOWN
12	<a href="#">21296</a>	1	POWER SUPPLY, EAC, W/DRIVER, 120V
13	21510	1	DISTRIBUTION BLOCK, 12-PL, 12-26 AWG, BLACK
14	<a href="#">21101</a>	1	SOCKET, RELAY, 8 PIN, 300V, 10A
15	<a href="#">21102</a>	1	RELAY, 240VAC, DPDT, 10A, PLUG IN
16	<a href="#">21337</a>	1	TRANSFORMER, 230VAC >115VAC @.86A
17	96760	1	COMPONENT BOX COVER
18	21509	1	DISTRIBUTION BLOCK, 12-PL, 12-26 AWG, RED

\* Hidden

## GEF & GEF-VH Fryers

## Parts List

Notes:

## A. Connecting Optional KITCHENTRAC®



If you purchased a new *Giles* cooking appliance with optional, factory-equipped, **KITCHENTRAC® Remote Monitoring**, it comes to you ready for connection to the **KITCHENTRAC®** server, via your establishment’s WiFi network. The app provides remote monitoring of equipment performance, productivity, menu trends, maintenance events and a multitude of other analytics pertaining to the appliance.

Three (3) levels of service are available when creating an account: **Basic**, **Business** & **Enterprise**. **Basic** service is included with purchase of the **KITCHENTRAC®** option & provides limited functionality to *view data only*. **Business** & **Enterprise** levels require monthly service fees, but offer enhanced capabilities to remotely edit fryer settings & receive notification of problems via email or text. The **Enterprise** level even includes extensive monitoring by Giles Technical associates with automatic repair dispatch for warranty equipment.

A **WiFi Connection Manual, Form #66313** was shipped with your new equipment ... the following information also explains the process to connect controller to the **KITCHENTRAC®** server. After equipment is installed & checked out, follow these instructions precisely to get connected and begin experiencing the benefits of remote equipment monitoring.

Should you encounter any difficulties with the process, please contact **GILES Technical Services @ 800.554.4537** or email [services@gfse.com](mailto:services@gfse.com).

### A.1 Connecting WiFi Board to Wireless Router

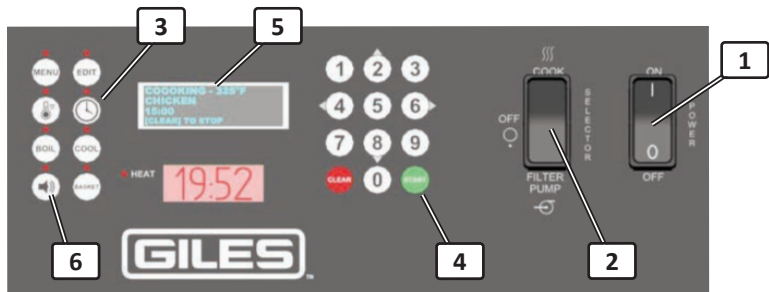

*There are minor differences in control panel layout & configuration between appliance models.*

**IMPORTANT!** *There must be a continuous open connection to the internet with a wireless WiFi router, which is within range of the monitored equipment. The password for the establishment router may be required.*

1. Place **POWER** switch ① to [ON] ... controller powers-up ... when alarm sounds, press [ALARM] key ⑥ to silence. Be sure to keep **SELECTOR** or **HEAT** switch ② in the [OFF] position throughout the process to prevent fryer heat from energizing.
2. Press [TIME] key ③ + **9 4 3 4** on keypad + [START] key ④.  
The message **“WiFi SETUP PRESS [START]”** appears on the upper display screen ⑤ ... press [START] key.
3. The message **“SEARCHING FOR WIFI MODULE”** will appear on display screen.  
If the WiFi module is not found within **10 seconds**, the message **“COMMUNICATIONS ERROR, CHECK CONNECTIONS”** will be displayed. Several issues can cause this error ... DIP switches on board are not set properly, cable is loose or disconnected, jumpers are missing, etc.  
Turn **POWER** switch OFF ... check WiFi board & cables, then retry. If the error persists, call **Giles Technical Services @ 800.554.4537** for assistance.
4. When module is successfully found, the message **“WIFI MODULE FOUND, CONFIGURING”** appears on screen.

## A.1 Connecting WiFi Board to the Wireless Router - continued

5. The display screen will cycle through the messages below as configuration proceeds:
  - **“WIFI MODULE FOUND, GETTING STATUS”**
  - **“STARTING CONFIG PORTAL”**
  - **“PORTAL ENABLED, CONNECT TO WIFI”**

6. When **“CONNECT TO WIFI”** appears ... open *WiFi Settings* on a smart-phone [*Android or iPhone*] to display available networks ... select ***KitchenTrac\_Config***. This is the network being broadcast by fryer’s WiFi board for set-up.

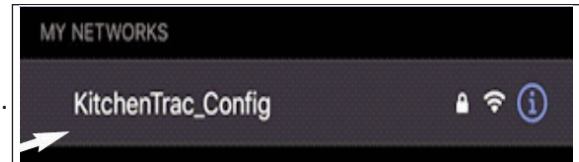

You will be prompted to enter a password ... password is **kitchentrac** (all lowercase).

7. The phone should open a *captive portal*.
 

**NOTE: If the captive portal does not automatically open after about 30 seconds, open the phone’s web browser and type in IP address - 10.10.0.1 + enter.**
8. On the phone, select the establishment’s WiFi network to which you are attempting to connect. Enter the router password (*if necessary*), then tap the **“JOIN”** button.

## A.2 Establishing Communication with KITCHENTRAC® Server

1. A **PAIR CODE** must be communicated to ***GILES Tech Service*** while the person performing the connection procedure is on-site with access to the equipment.
 

If the previous steps were successful the **PAIR CODE** should be displayed on the fryer controller screen. The code regenerates to a different value every **15 minutes** ... whatever code is displayed while in contact with *Giles Services* is the one that must be registered before the app is active & monitoring begins.

If **PAIR CODE** does not appear, go to **step #2 of Section A.1** & try the connection process again.

When you have acquired the code, call ***GILES Tech Service @ 800.554.4537*** and inform the *Tech Service representative* of the code and they will enter it into the ***KITCHENTRAC®*** website.

  - If a **PAIR CODE** did not appear during *Step #1*, you might try viewing the **“WIFI SYSTEM LOG”** on the fryer controller screen to acquire it.
    - Press **[TIME]** key + **7 7 7 7** + **[START]** key on controller.
    - Press keypad right arrow key **[6>]** until **“WIFI SYSTEM LOG”** is displayed on the *upper screen*.
    - A **PAIR CODE** should be shown.
    - Call ***GILES Tech Service @ 800.554.4537*** & communicate the displayed code to the *Tech Service representative* for entering into the ***KITCHENTRAC®*** website.
3. After **PAIR CODE** has been entered, verify that the controller is actually connected to the server.
 

To confirm connection success, enter *controller diagnostics mode* by pressing **[TIME]** key + **7 7 7 7** + **[START]** key, then press keypad right arrow key **[6>]** until *upper display* shows *Connection Status* ... displaying either **“SERVER CONNECTED”** or **“NOT CONNECTED”**.

If communication if has not been established, it is possible that there are problems with internet connectivity at your location, or the wireless router is possibly not within range of the appliance. ***Please contact GILES Tech Service for assistance in resolving the issue.***

## A.3 WiFi Components

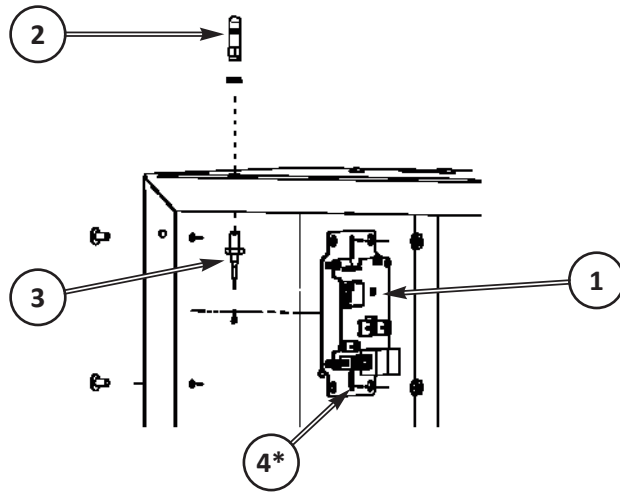

WiFi boards are located in various locations inside the appliance cabinets, depending on model. An antenna will protrude from cabinet near its location.

**IMPORTANT!** Take care not to damage the antenna when cleaning or servicing the equipment.

ITEM	PART NO.	QTY	DESCRIPTION
1	21606	1	WiFi BOARD ASSY, EXT ANTENNA
2	21613	1	ANTENNA, WiFi, 2.4GHz, RP-SMA, 1.8dB
3	21614	1	CABLE, ANTENNA, RF, U.FL TO RP-SMA, 15-IN
4	21454*	1	CABLE, CONNECTOR, RJ45, PLUG-TO-PLUG, 6-FT
	21615*	1	CABLE, CONNECTOR, RJ45, PLUG-TO-PLUG, 12-FT ( <i>VENTLESS MODELS ONLY</i> )

\* Not shown - connects board to controller in the Control Panel on front of unit.



P.O. Box 210247 • 2750 Gunter Park Drive West • Montgomery, AL 36121-0247 USA  
Phone 334.272.1457 • Toll-Free 800.554.4537 (USA & Canada Only) • FAX 334.239.4117 • [www.gfse.com](http://www.gfse.com)

Form No. 60831 (Rel. Jun.2003; Rev. Jul.2022, Rev. L)