

Operation & Service Manual



MODELS:
GGF-400
GGF-720

 **CAUTION:** Read instructions before using this appliance.

IN A PROMINENT LOCATION, post instructions for the actions to be taken in the event personnel smells gas.
This information can be obtained by contacting your local *Gas Utility Company*.

FOR YOUR SAFETY

DO NOT store, or use flammable liquids, or any materials which may produce flammable vapors, in the vicinity of this or any appliance.

 WARNING

- **DO NOT install or use gas fired appliances in areas without sufficient ventilation to provide adequate room air exchanges in order to prevent accumulation of combustion flue gases (carbon monoxide & CO₂). Improper installation or use can result in personal injury, even death.**
- **Read the installation, operating & maintenance instructions thoroughly before installing & attempting to operate or service this appliance.**



LIMITED WARRANTY

- Subject to the terms and conditions of this Limited Warranty as herein stated, all Giles Enterprises Inc. (hereafter referred to as “Giles”) food service equipment & parts purchased new from an authorized Giles distributor/dealer are warranted as to defects in material or workmanship for a period of twenty-four (24) months from the date of installation, provided, however, that with regard to labor costs in connection with this warranty, see below. All installations must be made by a qualified kitchen equipment service contractor in accordance with all applicable codes and/or regulations in the jurisdiction where installed. Limited warranty coverage is extended only to the original owner and is void if the unit is resold.
- During the Limited Warranty period, Giles will replace or recondition, any part or parts of this unit which Giles inspectors judge defective, provided the unit has been properly installed, subjected to normal usage, and operated and maintained in accordance with specified procedures. This Limited Warranty does not cover cosmetic damage and damage due to: acts of God, accident, misuse, alteration, negligence, abuse, or use of unorthodox repair methods. All parts replaced under this Limited Warranty carry only the unexpired term of this Limited Warranty. Limited Warranty service may be furnished only by an authorized Giles service company.
- If Limited Warranty service is requested, Giles will dispatch factory-authorized service representatives to inspect, repair, recondition, or replace units of its manufacture with such labor being rendered without cost to owner for twenty-four (24) months from the date of installation. Otherwise, service, including labor and transportation charges or other expenses, in connection with the removal or installation of any part or parts supplied under this Limited Warranty, are specified on the original sales contract between the purchaser and the authorized Giles representative.
- **Failure to use Giles OEM replacement parts and Giles OEM filters may void this Warranty.**
- Giles reserves the right to change or enhance its equipment and/or parts in any way without obligation to alter such equipment or parts previously manufactured.
- Giles makes no further warranties, express or implied, including implied warranties of merchantability or fitness for a particular purpose, and has no other obligation or liability not specifically stated herein.
- Repair or replacement as provided under this limited warranty is the exclusive remedy. Giles shall not be liable for any incidental or consequential damages for breach of any express or implied warranty on this product, except to the extent prohibited by applicable law. Any implied warranty of merchantability or fitness for a particular purpose on this product is limited in duration to the duration of this limited warranty.
- Used Giles food service equipment or parts, or Giles food service equipment or parts not purchased from an authorized Giles representative, carry no warranties, express or implied.

Safety	iii
Safety Overview	iii
Specific Safety Precautions	iv
1. Introduction	1
1.1. Construction	1
1.2. Standard Features	1
1.3. Optional Features	1
1.4. Specifications	2
1.4.1. Overall Dimensions: GGF-400 & 720	2
1.4.2. Agency Certifications	3
1.4.3. Basket Sizes	3
1.4.4. Cooking Capacity	3
2. Installation	5
2.1. Appliance Location	5
2.2. Unpacking	6
2.3. Clearances & Utility Connection Locations	7
2.4. Ventilation	8
2.5. Utility Requirements	8
2.5.1. Electrical Specifications	8
2.5.2. Fuel Gas Specifications	8
2.6. Electrical Connections	9
2.7. Gas Line Connection	9
2.7.1. Typical Gas Supply Line Connection	10
2.8. Gas Orifices: Informations & Replacement Procedure	11
2.9. Gas Pressure Setting and Adjustment	13
2.10. Blower Vacuum Switch Setting and Adjustment	14
2.11. Restraint Device	15
2.12. Finalizing Installation	15
2.12.1. Power Test	17
2.12.2. Burner Test	17
2.12.3. Filter Pump Test	18
2.12.4. Pre-Use Fryer Cleaning	19
2.12.5. Optional KITCHENTRAC® Overview	19
3. Overview	21
3.1. Control Panel	22
3.2. Lower Cabinet	24
3.3. Filter Pan Assembly	26
3.4. Basket & Elevator Assembly	28
3.5. Accessories (Included)	30
3.6. Accessories (Not Included)	32
4. Fryer Operation	35
4.1. Computer Cooking Controller	36

4.1.1.	Keypad & Function Keys.	36
4.1.2.	General Operation - Fryer Controller	38
4.1.3.	Manually Entering Cook Time & Temperature	39
4.1.4.	Working with Menu Item Presets	40
4.1.4.1.	Editing a Menu Preset	41
4.1.4.2.	Selecting a Menu Preset for Cooking	44
4.1.5.	Cooking Cycle - General Overview	45
4.1.6.	Other Controller Features	45
4.1.6.1.	Manually Operating the Basket Lift.	45
4.1.6.2.	COOL Mode.	46
4.1.6.3.	AUTO-COOL Feature.	46
4.1.6.4.	Boil-Out Program	46
4.1.7.	Controller User Settings.	47
4.1.8.	PASSWORD Protection	48
4.1.9	Start-up Procedure	48
4.1.10	Controller Errors & Alarms.	49
4.1.10.1	Resolving Controller Errors & Alarms	50
4.2.	Cooking Procedures	50
4.3.	Filtering Used Cooking Oil	56
4.4.	Removing Waste Oil from Fryer	61
4.5.	Normal Shutdown	64
4.6.	Emergency Shutdown	64
5.	Cleaning	65
5.1.	Boil-Out Procedure (Cleaning the Fry Pot)	65
5.2.	Cleaning the Filter Pan & Refreshing Filter Media	68
6.	Troubleshooting	69
6.1.	Temperature Control System	67
6.2.	Oil Filtration System	72
6.3.	Basket Lift System.	73
7.	Parts List	75
7.1.	Parts Ordering & Service Information.	75
7.2.	Front Header & Control Panel	76
7.3.	Front Lower Cabinet.	78
7.4.	Rear Cabinet	80
7.5.	Plumbing - Standard.	82
7.6.	Plumbing - Waste Oil Option	84
7.7.	Basket & Basket Cover	86
7.8.	Filter Pan	88

Safety Overview

The instructions contained in this manual have been prepared to explain the proper procedures for installing, operating and servicing **Giles Model GGF Series Gas Fryer**.

Throughout the manual, safety precautions are identified by a hazard alert symbols and notifications such as **DANGER**, **WARNING** or **CAUTION**. Alert information precedes the tasks to which it applies. Suggested, recommended, or other noteworthy information is identified as **NOTES**, or will be marked as **IMPORTANT!**. Additionally, certain words are used to indicate a specific meaning, or to add emphasis as follows:

Shall: understood to be mandatory.

Should: understood to be advisory.

May: understood to be permissive.

Will: indicates a future event or condition to occur.

 **Hazard Alert Symbols** are used in conjunction with notifications **DANGER**, **WARNING**, or **CAUTION**, to alert users of potential personal injury hazards and/or poor operating practices. Notification will immediately precede the precautionary measures pertaining to avoiding such hazards or practices. Adhere to all information following these symbols to avoid possible injury, or even death. Failure to do so may also void the factory warranty.

 *This product can expose Users to chemicals including lead, nickel, cobalt, aluminum, cadmium, brass, carbon, copper or BPA which are known in the state of California to cause cancer, birth defects and other reproductive harm. For more information go to: www.p65warnings.ca.gov.*

DANGER

Indicates an imminently hazardous situation which, if not avoided, will result in serious personal injury, even death.

WARNING

Indicates a potentially hazardous situation which, if not avoided, could result in serious injury, even death.

CAUTION

Indicates a potentially hazardous situation which, if not avoided, may result in minor to moderate injury. This notification is also used as an alert to unsafe practices.

CAUTION

If used without the safety alert symbol, indicates a potentially hazardous situation which, if not avoided, may result in equipment and/or property damage, and may void the factory warranty.

NOTE or IMPORTANT!

Identifies suggested, recommended, or other important information.

Specific Safety Precautions:

For your safety, please observe the following precautions when operating or servicing the equipment. Adhering to the following important safety precautions will help personnel avoid personal injury and/or prevent damage to the equipment.

⚠ DANGER

- Before cleaning or performing maintenance, place **POWER** switch in the **OFF** position. To remove all power, unplug power cord or turn **OFF** power at the electrical panel supplying power. Close valves on the gas supply line & place fryer's *gas valve handle* in **OFF** position.
- **DO NOT** wash down the appliance interior or exterior with water from a spray hose.
- Failure to comply with **DANGER** notices will result in serious injury, even death; or damage to equipment and/or property and may void the factory warranty.

⚠ WARNING

- Fryer must be installed & used only in locations that have positive ventilation to the outside, sufficient to provide adequate room air exchanges necessary to prevent accumulation of hazardous combustion gases (carbon monoxide & CO₂). Combustion gases must be vented to the outside in accordance with the prevailing *National Fuel Gas Code, ANSI Z223.1*. Failure to comply can result in personal injury, even death.
- The equipment must be adequately & properly grounded. Improper grounding may result in electrical shock to operators. Always refer to local electrical code to ensure proper grounding of this or any other electrical equipment.
- Check the rating label on the unit to confirm the proper required power supply. Consult a professional electrician or service technician to ensure that the installation will comply with the appliance's electrical requirement, compliance with all local codes, and that electrical circuits are of sufficient rating to power the appliance load. A wiring diagram is provided. **The appliance must be installed & electrically grounded in accordance with local code, or in the absence of local code, in accordance with the *National Electrical Code, NFPA 70*.**
- Improper installation, equipment adjustments or alterations, service, or maintenance could result in serious injury, even death; equipment and/or property damage & will potentially void the factory warranty.
- **DO NOT** use or store flammable liquids, or materials that produce flammable vapors, in the vicinity of this or any other appliance!
- **For any reason, DO NOT (or ALLOW OTHERS TO) stand or step onto the top of the appliance.** Cooking oil in fryers can be **EXTREMELY HOT (excess of 330°F [166°C])**. Bodily contact will cause extremely serious injury. Lids used to sometimes cover cooking vats/pots are not designed to, and **WILL NOT** support the weight of a person. 
- Failure to comply with **WARNING** notices could result in serious injury, even death; damage to equipment and/or property; and will potentially void the factory warranty.

CAUTION

- The appliance must remain in an upright position.
- Exercise care when removing the unit from shipping pallet.
- **DO NOT** operate the appliance unless you completely understand its components & their intended functions (see **Section 3**). Closely follow the presented procedures & instructions in order to avoid damage or malfunction.
- **To avoid personal injury, it is recommended that personal protective equipment (gloves or mitts) be worn while tending the appliance.** Certain parts of the fryer will become very **HOT** ... temperatures inside cabinet may exceed **150°F (65.5°C)**! Exercise caution when operating & cleaning.
- Placing foods which contain excessive moisture into hot oil, or attempting to load larger than recommended batch sizes can cause “surge boiling” & result in an overflow of **HOT** oil. Proceed slowly & exercise due care when loading food to observe how the hot oil reacts before continuing.
- Be sure the appliance is located in a stable, safe location with the casters in the locked position. **DO NOT** operate appliance if not secured. Some jurisdictions may require special anchoring for this type appliance ... check local codes.
- Allow appliance to cool for 15 to 20 minutes before cleaning or servicing.
- This appliance is not intended for use by persons (including children) with reduced physical, sensory, or mental capabilities, or lack of experience and knowledge, unless they have been given adequate instruction and/or supervision concerning its use by a person responsible for their safety. Children should not be allowed to play with, or around, this appliance.
- Prior to sale, cooked food products must be maintained at a minimum temperature of 150°F (65.5°C), or in accordance with governing health regulations.

CAUTION

- Components exposed on the control panel surface are impact-sensitive. To avoid damage & maintain proper operation, exercise care when using rolling carts or tables near the appliance.
- The control panel contains a high-tech micro-processor controller. **While the front panel is liquid-resistant, it is not completely wash-down safe.** When cleaning, avoid spraying directly with water spray.
- **DO NOT** install the unit near combustible walls & materials. Failure to maintain safe distance may result in fire.
- When cleaning the appliance:
 - **DO NOT** steam clean.
 - **DO NOT** use products containing chlorine, or other corrosive chemicals.
 - **DO NOT** use abrasive products, steel wool or scouring pads.
 - **DO NOT** use oven cleaners.
- **DO NOT** alter, add attachments, or otherwise modify this equipment!
- Failure to comply with **CAUTION** notices may result in damage to equipment or property, and void the factory warranty.

NOTE:

- Comply with all appropriate state and/or local health regulations regarding food safety & cleaning/sanitization of equipment and accessories.

1. Introduction

THANK YOU for purchasing the *Giles Model GGF Series Gas Fryer*, manufactured by *GILES Food Service Equipment*; Montgomery, Alabama (USA), hereafter referred to as "Giles". Every unit is thoroughly inspected & tested prior to shipment in efforts to ensure that it will operate flawlessly when installed. With proper care & maintenance the appliance will provide years of trouble-free service.

To help protect your investment in this state-of-the-art equipment, we recommend that you take a few moments to become familiar with the procedures for installation, operation, cleaning & maintenance contained in this manual. Adherence to these recommended procedures will minimize the potential for costly appliance downtime & future repair expense. Please retain this manual for future reference.

NOTE: Due to continuing improvements and product enhancements, some of the illustrations shown in this manual might not exactly depict current models.

1.1 Construction

Constructed of stainless steel formed sheet metal.

1.2 Standard Features

Computer Controller - Accurately controls cooking oil temperature & cooking time. Programmable cooking presets for up to 50 menu items. Constantly monitors fryer status & displays operational instructions, warnings and errors, such as **DRAIN OPEN, LOW OIL LEVEL, MAX. ELEMENT TEMP**, etc. Features **BOIL-OUT** program, **COOL MODE, FORCE FILTER** control, password security, three language selections, and enhanced safety features.

Dual Burner System (GGF-720 only) - Unique *energy-saving* dual-burner configuration delivers maximum heat input when needed after initial cold food drop, then cuts back to one burner when temp recovers, until it drops again by 3-degrees while cooking. One burner is also usually sufficient to maintain oil temp during brief idle periods.

Automatic Basket Lift - Automatically lowers basket of product when cook cycle is started and lifts cooked product from hot oil at the conclusion of the programmed cooking time.

Built-in Oil Filtration System - Fully self-contained system ... when used properly, can help to extend the useful life of cooking oil. Robust 1/2 hp pump designed to perform a filtering cycle in approximately five (5) minutes.

Push-To-Start Feature - After a power any interruption, operator must press **[START]** key on controller to power-up the appliance. This feature will comply with code requirements in some jurisdictions.

1.3 Optional Features

Woven-wire Mesh Filter Media [purchased separately] - Stainless steel, sustainable & reuseable filter screen ... a direct replacement for *filter paper*. With proper care this screen will serve for many months & helps to reduce the total cost of operation & the kitchen waste stream. **Order Part Number: 41014**

1.4 Specifications

1.4.1 Overall Dimensions

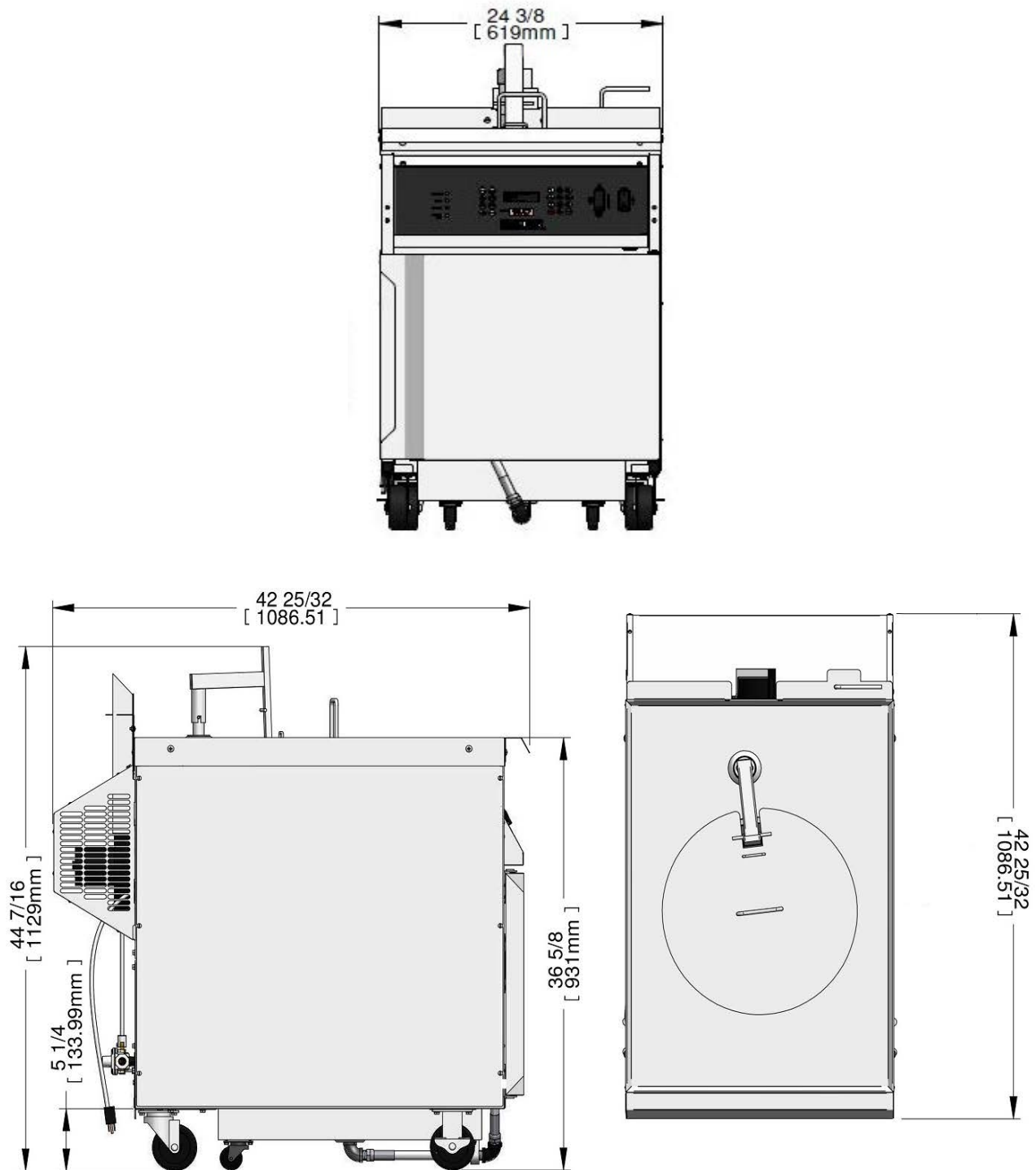

INCHES [mm]

1.4.2 Agency Certifications



1.4.3 Basket Size

Model	Basket Size		Volume
	Diameter: in [mm]	Height: in [mm]	Cubic inch [Cu m]
GGF-400	12-3/8 [314.2]	10-1/4 [260.4]	1,231.8 [.020]
GGF-720	14-3/4 [374.7]	12-3/4 [323.9]	2,178.6 [.036]

1.4.4 Cooking Capacity

Model	Cooking Oil Capacity**		Product Capacity (*Chicken)
	Lbs [kg]	Gal [l]	Lbs [kg]
GGF-400	45 [21]	5.8 [21.9]	14 [6.3]
GGF-720	75 [34]	9.7 [36.7]	24 [10.8]

** Never exceed [MAX] oil level

* 8-way cut, bone-in

CAUTION

Exceeding the product load capacity or over-filling fry vat with oil may result in personal injury and/or damage to equipment or property.

2. Installation

This section summarizes procedures necessary for proper installation of the **GGF** gas fryer. To avoid personal injury or damage to the equipment, please ensure these steps are properly followed by using the **INSTALLATION CHECKLIST** below. For future reference, initial and date at completion of each item.

CAUTION

Various installation tasks described in this manual **MUST** be performed only by a licensed professional electrician or qualified gas technician/plumber.

NOTE: The appliance must be electrically grounded in accordance with local code, or in the absence of local code, with the **National Electrical Code, ANSI/NFPA 70**, or **Canadian Electrical code, CSA C22.2**, as applicable.

INSTALLATION CHECK SHEET				
Check	Date	Initial	Section	Description
X	8/18/05	CSY	0.0	Review entire Operations Manual & Section 2 thoroughly
			2.1	Select location for appliance
			2.2	Inspect for shipping damage & uncrate fryer
			2.3	Confirm proper clearances
			2.4	Confirm proper ventilation is provided
			2.5	Verify utility requirements ... electrical & fuel gas
			2.6	Electrical connection
			2.7	Gas line connection (gas service personnel)
			2.8	Verify elevation, confirm correct orifice installed (gas service personnel)
			2.9	Correct gas pressure setting (gas service personnel)
			2.10	Set blower vacuum switch (gas service personnel)
			2.11	Restraint device installed
			2.12	Finalize Installation
			2.12.1	Power Test
			2.12.2	Burner Test
			2.12.4	Initial Fry Pot Cleaning
			2.12.5	General Initial Cleaning

2.1 Appliance Location

WARNING **DO NOT MODIFY, ADD ATTACHMENTS OR OTHERWISE ALTER THIS EQUIPMENT.**

DO NOT install or use the appliance in kitchen spaces, or any other areas, that do not have positive ventilation to the outside. Ventilation must be sufficient to provide a room air exchange rate (ACH) sufficient to prevent accumulation of hazardous combustion gases (CO & CO₂). Failure to comply can result in personal injury and even death.

2.1 Appliance Location - continued

1. Installation location must comply with clearances to combustibles stated in **Section 2.3**.
2. Provide adequate space for easy access to operate & service appliance.
3. Verify that electrical power at the intended location is proper voltage & amp rating. Each appliance requires an **isolated, properly grounded, 120V, 15A (min), non-GFCI circuit**.
4. The proper type, stable fuel gas supply must be available. A 1/2" supply line, fitted with "service" shutoff valve is required.
5. Be sure unit will be located in a stable position & will not move unintentionally. Cabinet is equipped with casters ... front wheels have locking brakes ... be sure they are used. Code in some jurisdictions may require additional special anchoring of the appliance ... check local code (see **Section 2.13, Restraining Device**).
6. Appliance shall be installed, used & maintained in accordance with the **Standard for Ventilation Control & Fire Protection of Commercial Cooking Operations, NFPA 96**.

If there are questions concerning installation procedures, contact **Giles Technical Support** at **800.554.4537** or email **services@gfse.com**.

2.2 Unpacking

IMPORTANT!

If crate exhibited evidence of damage or mishandling, immediately inspect the unit & all accessory items. Immediately notify the freight carrier of damages. Typically it is the purchaser's responsibility to file & negotiate freight damage claims.

Giles shall not be liable for damages to the unit caused by use of improper material handling equipment or poor work practices, or for personal injuries or property damage which may be incurred during installation. Installation expenses are the sole responsibility of purchaser, unless previous arrangements have been made in writing.

CAUTION

- The fryer must remain in an upright (vertical) position.
- Exercise care when lifting & moving the unit.
- Use due caution when removing the wooden crating & shipping materials.
- Failure to comply with **CAUTION** notices may result in minor to moderate injury, damage to equipment or property & void the manufacturer's warranty.

1. The appliance is palletized on a wooden pallet, secured with high-tensile plastic strapping & protected by a wooden crate framework. The entire unit load is wrapped with machine applied stretch film.
2. Carefully cut & remove the plastic stretch film wrap.
3. Carefully remove the wooden crate framework, cut & remove plastic strapping. Secure & remove all accessory items (*basket, pot cover, brushes, tools, filter pan, etc.*). Set aside in a safe place ... properly dispose of shipping materials.
4. Carefully remove fryer from the shipping pallet. The appliance is heavy [approximately 280 lbs, 127 kg]. Extreme care should be taken when lifting & moving the unit to prevent personal injury and/or damage to the equipment. Use sufficient manpower and/or appropriate handling equipment.

2.3 Clearances & Utility Connection Location

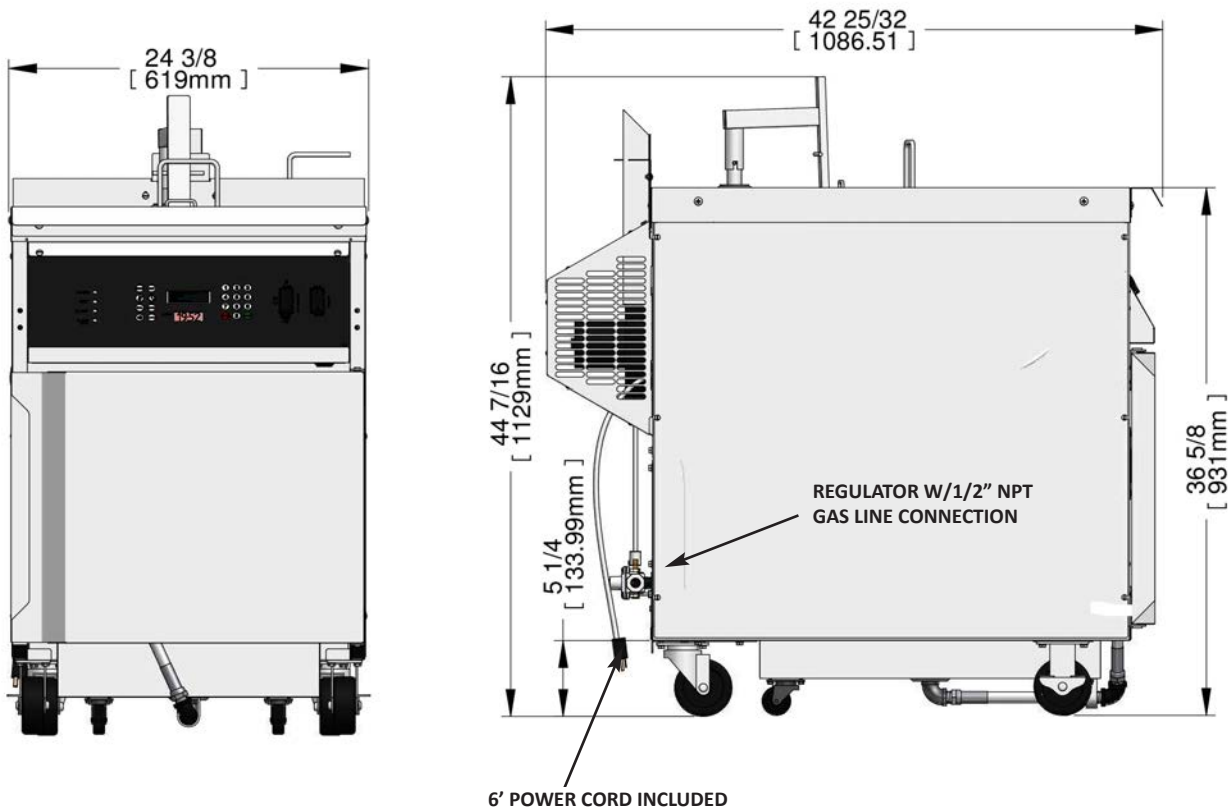
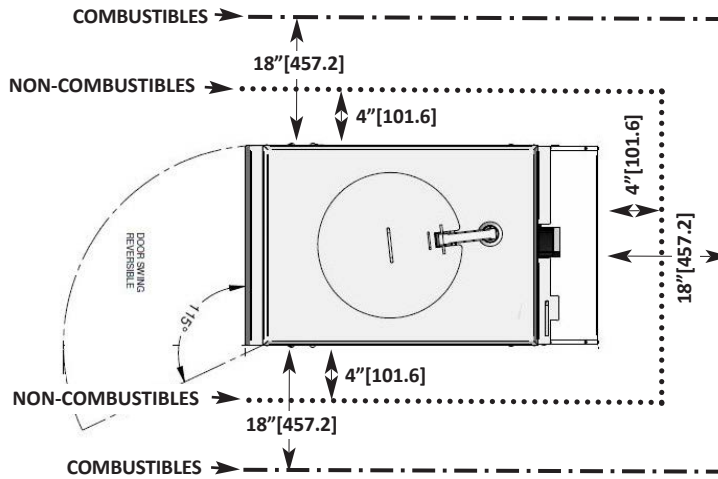

INCHES [mm]

2.4 Ventilation

NOTE:

Guidelines for ventilation system requirements may differ by locale. Always consult with local authorities to ensure compliance for this appliance.

- **Combustion gases produced by this appliance must be vented to the outside in accordance with the prevailing National Fuel Gas Code, ANSI Z223.1 & terminate with a UL listed outside vent terminal. For Canadian installations reference CSA-B149.1 or .2, Installation Codes for Gas Burning Appliances & Equipment.**
- The appliance is to be installed, used and maintained in accordance with the **Standard for Ventilation Control & Fire Protection of Commercial Cooking Operations, NFPA 96.**
- Consult a professional, HVAC contractor for assistance in designing & specifying a ventilation hood system for this unit. Recirculating ventilation hoods **CANNOT** be used for this & other gas-fired appliances.

2.5 Utility Requirements

CAUTION

Fryers must be adequately & properly grounded. Improper grounding may result in electrical shock to users. Always refer to local electrical code to ensure proper grounding of this or any other electrical equipment. Always consult with a qualified electrician or service technician to ensure breakers & wiring are of sufficient rating & gauge to supply power for the equipment.

Table 2.5.1. Electrical Specifications

Model	Voltage	Hz	Ph	Amps	Breaker Required
GGF-400 & 720	120	60	1	9.2	15

Fuel Gas Specification: Giles GGF gas fryers are available from the factory configured to operate with either of the fuel types shown below. *It is important to comply with the indicated gas pressure specifications.*

Table 2.5.2. Fuel Gas Specifications

Fuel Type	Max. Incoming Supply Pressure to Fryer Gas Inlet	Max. Regulated Pressure to Fryer Gas Control Valve	Supply Line Size
Nat. Gas	13.85" w.c. [3.45 kPa]	5" w.c. [1.23 kPa]	1/2"
LP Gas	13.85" w.c. [3.45 kPa]	11" w.c. [2.99 kPa]	1/2"

2.6 Electrical Connections

1. Connect fryer power cord to an appropriately **grounded, isolated, 120V, 15A (min), non-GFCI receptacle** ... See **Table 2.5.1**.
2. Fryer has a 6 ft. power cord with a molded **NEMA 5-15P** plug.
3. Because the fryer's electronic gas ignitor system is designed to arc to ground to ignite the burners, it is necessary that only a **non-GFCI** receptacle be used for power. The ignitor will cause a **GFCI** to trip and interrupt fryer power. To avoid such nuisance interruptions **DO NOT** connect the appliance to a **GFCI** receptacle.



IMPORTANT!

When installed, appliance must be electrically grounded in accordance with local code, or in the absence of local code, with the **National Electrical Code, ANSI/NFPA 70, or Canadian Electrical Code, CSA C22.2**, as applicable.

2.7 Gas Line Connection

⚠ WARNING

- Combustion gases produced by this appliance must be vented to the outside in accordance with the prevailing **National Fuel Gas Code, ANSI Z223.1** & terminate with a UL listed outside vent terminal. For Canadian installations reference **CSA-B149.1 or .2, Installation Codes for Gas Burning Appliances and Equipment**.
- Quick-disconnect devices must comply with the **Standard for Quick-Disconnect Devices for Use with Gas Fuel, ANSI Z21.41 [in Canada CSA 6.9-2014]**.
- Gas connectors & supply lines must comply with **Standard for Movable Gas Appliance, ANSI-69, and Addenda Z21.69 [in Canada CSA 6.10-2015]**.
- The unit **MAY** require installation of a secondary in-line gas pressure regulator (*customer supplied*), see **Section 2.5, Utility Requirements & Table 2.5.2, Fuel Gas Specifications**.
- The unit **MUST** be connected to gas supply by qualified gas service personnel.
- Ensure both the facility shut-off valve & the fryer shut-off valve are in the [OFF] position.

Verify that a proper facility gas supply line (1/2" min.) is install & equipped with a "service" shut-off valve (**not provided**). See **Section 2.8.1, Typical Gas Supply Line Connections**.

2.7.1 Typical Gas Supply Line Connection

IMPORTANT!

- Installation must comply with local code, or in the absence of local code, with the **National Fuel Gas Code, ANSI Z223.1/NFPA 54** [in Canada, **Natural Gas & Propane Installation Code, CSA B149.1**] including:
- The appliance must be disconnected from the incoming gas supply line at the main shut-off valve, during any testing of piping at test pressures **in excess of 1/2 psi (3.5kPa)**.
- The appliance must be isolated from the incoming gas supply line by closing the fryer *gas shutoff valve*, during any testing of piping at test pressures **equal to or less than 1/2 psi (3.5kPa)**.

1. Check pressure on incoming gas supply & compare to **Table 2.5.2**. If necessary install a secondary pressure regulator to regulate supply pressure to a maximum of **13.85" W.C. [3.45 kPa]**.
2. Install an appropriate quick-coupling fitting on the gas line.
3. Connect an approved 1/2" flexible gas line (**not provided, purchased separately**) between supply line & fryer gas regulator located on rear of the unit.
Note: The flexible gas line should be long enough to allow for the fryer to be moved away from wall for any servicing & cleaning.
4. **WHEN TIGHTENED, CHECK ALL CONNECTIONS FOR LEAKS USING A SUITABLE METHOD!**

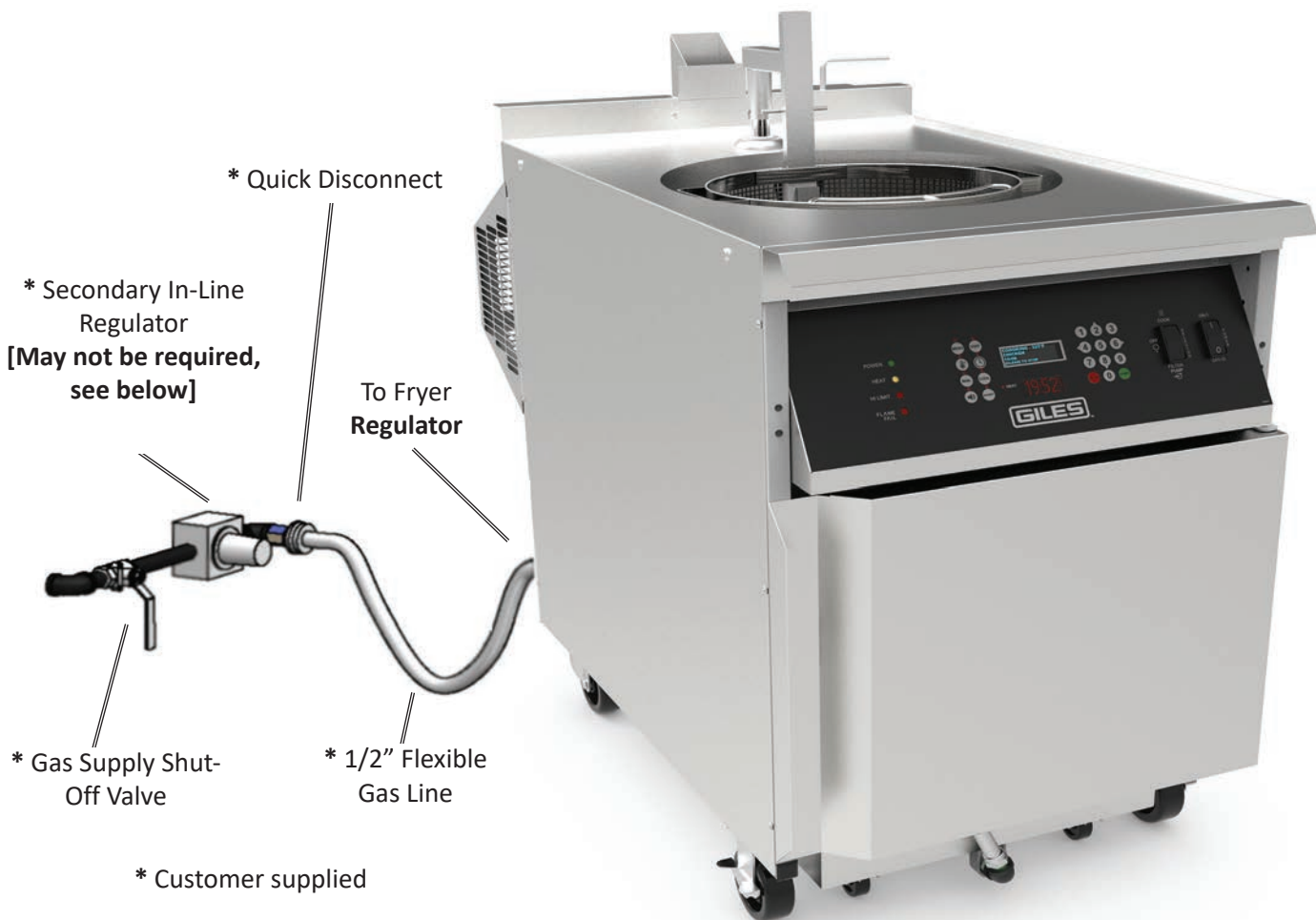

2.7.1 Typical Gas Supply Line Connection - continued

IMPORTANT!

The factory-installed regulator on the fryer controls gas pressure supplied to the gas valve as shown in **Table 5-2.2**. This regulator is rated for max. input pressure of 13.85" W.C. [3.45 kPa]. **If supply line pressure exceeds this maximum, a secondary regulator must be installed in the supply line, upstream of the installed regulator, to maintain pressure at or below the maximum rating.**

2.8 Gas Orifices: Information & Replacement Procedure

IMPORTANT!

The fryer is manufactured & shipped with standard gas orifices for operation as follows:

Natural Gas: Sea Lvl to 3,000 feet AMSL

LP Gas: Sea Lvl to 4,000 feet AMSL

Verify the elevation of the installation site.

Gas flow varies at different elevations. If elevation is greater than those stated above, orifices must be changed to an appropriate size. To confirm that proper orifices are installed or to exchange, follow the steps below. Orifices are available from *Giles (call factory at 800.554.4537)* ... it is also possible that they can also be sourced locally ... consult charts below or label on fryer rear panel.

CAUTION Changing type of fuel gas will require a proper Conversion Kit ... contact factory.

2.8 Gas Orifices: Information & Replacement Procedure - continued

NOTE: The model GGF-720 is equipped with (2) burners, orifices, gas manifolds & gas lines.

1. Disconnect power plug from receptacle.
2. Ensure that all gas valves are OFF.
3. Remove rear fan guard & back cabinet panel.
4. It should be possible to examine the ID stamp on orifice head without removing them.
5. If orifice is incorrect for actual installation altitude, disconnect gas line and remove the *gas manifold*.
6. Remove & replace orifice in manifold with the proper size. **See charts below.**
7. Re-install manifold & installed orifice, reconnect gas line, and replace panel & guard. Proceed to **Section 2.10; Gas Pressure Setting and Adjustment.**

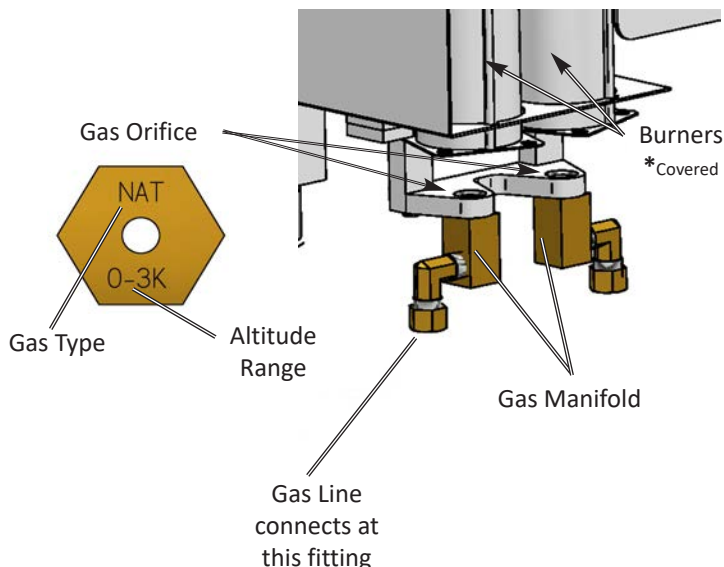

IMPORTANT! [Model GGF-720 with 2 Burners]

When removing & reattaching gas lines, for any service or maintenance event, be sure that they are reattached to the same burner manifold from which they were removed. Inadvertently switching these lines will result in ignition failures.

IMPORTANT! Orifice size charts ... see label on rear of unit

GGF-400 Fryer

NATURAL GAS				PROPANE			
ALTITUDE IN FEET	INPUT RATING	DRILL SIZE #	ORF P/N	ALTITUDE IN FEET	INPUT RATING	DRILL SIZE #	ORF P/N
0- 999	45000	30(.1285)	46719	0- 999	45000	48(.076)	46723
1000-1999	45000	30(.1285)	46719	1000-1999	45000	48(.076)	46723
2000-2999	43200	30(.1285)	46719	2000-2999	43200	48(.076)	46723
3000-3999	41500	31(.120)	46720	3000-3999	41500	48(.076)	46723
4000-4999	39800	31(.120)	46720	4000-4999	39800	49(.073)	46724
5000-5999	38200	31(.120)	46720	5000-5999	38200	49(.073)	46724
6000-6999	36700	31(.120)	46720	6000-6999	36700	49(.073)	46724
7000-7999	35200	32(.116)	46721	7000-7999	35200	50(.070)	46726
8000-8999	33800	32(.116)	46721	8000-8999	33800	50(.070)	46726

GGF-720 Fryer

NATURAL GAS				PROPANE			
ALTITUDE IN FEET	*INPUT RATING	DRILL SIZE #	ORF P/N	ALTITUDE IN FEET	*INPUT RATING	DRILL SIZE #	ORF P/N
0- 999	85000	30(.1285)	46719	0- 999	85000	48(.076)	46723
1000-1999	85000	30(.1285)	46719	1000-1999	85000	48(.076)	46723
2000-2999	81600	30(.1285)	46719	2000-2999	81600	48(.076)	46723
3000-3999	78300	31(.120)	46720	3000-3999	78300	48(.076)	46723
4000-4999	75200	31(.120)	46720	4000-4999	75200	49(.073)	46724
5000-5999	72200	31(.120)	46720	5000-5999	72200	49(.073)	46724
6000-6999	69300	31(.120)	46720	6000-6999	69300	49(.073)	46724
7000-7999	66500	32(.116)	46721	7000-7999	66500	50(.070)	46726
8000-8999	63900	32(.116)	46721	8000-8999	63900	50(.070)	46726

2.9 Gas Pressure Setting & Adjustment

The following procedure sets the fryer's gas valve to the proper output pressure to ensure that heat output (BTUs) of the burners will be as specified. **Requires a digital manometer capable of reading inches w.c. (water column).**

CAUTION Burners must be ignited when checking & adjusting gas pressure ... **NEVER** perform this without first having the fry pot filled with water.

1. Fill fry pot with clean water to the **FULL** mark.
2. Remove the lower rear panel from fryer cabinet.
3. Remove the *pressure tap plug* from gas valve. Install a fitting appropriate for attaching a digital manometer.
4. Remove the *pressure adjustment cover plug* from the valve.
5. Connect a digital manometer (reading inches w.c.) to the gas valve *pressure tap* & tighten.
6. Open the gas supply line valve & place the fryer's *gas shut-off valve* in the **[OPEN]** position.
7. Place the **POWER** switch in the **[ON]** position & allow controller to power-up. Press **[ALARM]** key to silence alarm, then press **[START]** key. Place **SELECTOR** switch in the **[COOK]** position.
8. Fryer begins ignition sequence ... you should hear ignitor sparking. Burner(s) should ignite momentarily ... unit will begin heating.
9. With burners ON, check the manometer pressure reading & compare to table below. If pressure matches for the type of fuel gas, NO adjustment is needed. If not, use a screwdriver to adjust the valve adjustment screw ... turn to right (clockwise) to increase pressure ... turn to left (counter-clockwise) to decrease pressure.

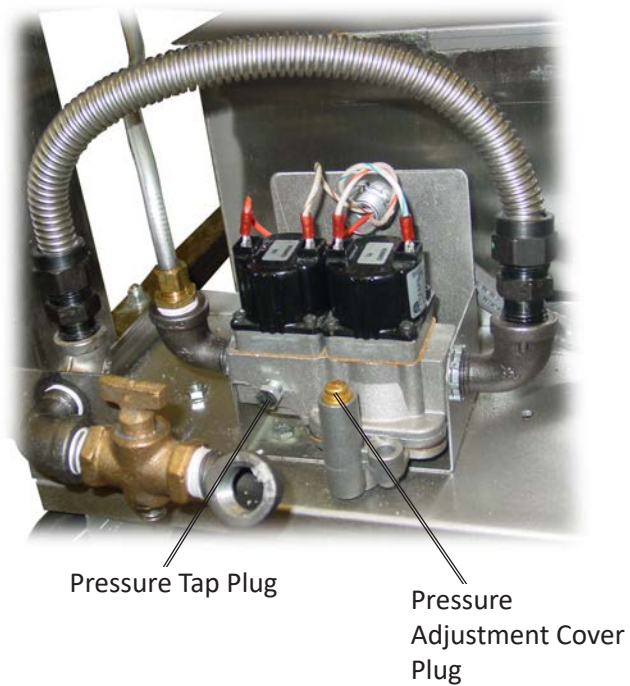

After adjusting, observe pressure for several minutes to confirm that it remains stable.

GAS TYPE	MODEL	IN. WATER COLUMN [w.c.]
NATURAL	GGF-400	4.0"
	GGF-720	3.5"
LP	GGF-400	11.0"
	GGF-720	10.5"

10. Return **SELECTOR** & **POWER** switches to **[OFF]** position.
11. Remove manometer tube ... replace & tighten the *pressure tap plug* and the *adjustment screw cover*. Replace rear fryer panel.
12. **Do not drain water** ... restart the fryer as described in **Step-7** and continue set-up ... see **Section 2.10, Blower Vacuum Switch Setting**.

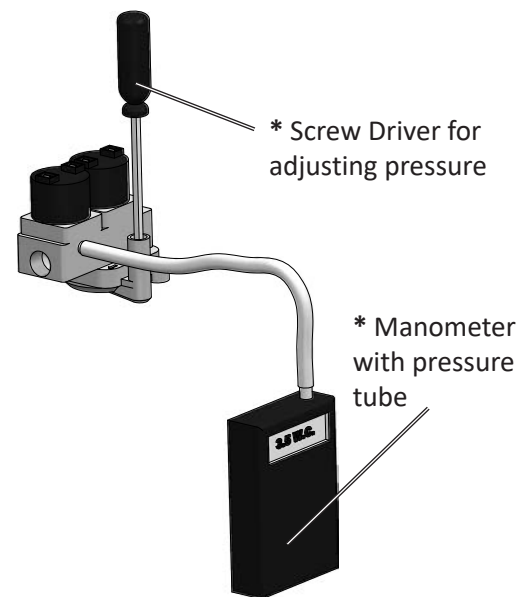

* Not supplied with unit

2.10 Blower Vacuum Switch Setting & Adjustment

The blower vacuum switch ensures that proper draft air-flow exist before allowing the gas valve to open for ignition. The switch is factory-set, but differences in conditions at installation sites can affect settings. Use the following steps to confirm that the vacuum switch is adjusted properly for the local conditions.

CAUTION

Burners must be ignited ... **NEVER** check or adjust the *blower vacuum switch* without having fry pot filled with water.

CAUTION

During the next steps use great caution & wear thermal hand protection. The air exhausted from the flue stack is **EXTREMELY HOT!!**

1. Restart fryer.
2. With burners **ON**, use a piece of ***non-combustible material*** to diagonally block (*corner to corner*) about half of the flue stack opening.
3. Burner(s) & the draft fan should shutdown. When the opening is unblocked, the fan should restart & burner(s) should re-ignite. If this occurs as described, the setting is satisfactory, go to **Step-8**.

If burner(s) fail to shutdown, the blower vacuum switch must be adjusted as follows:

4. Shutdown fryer.
5. Remove retaining screws at top of the control panel & lower panel.
6. Locate pressure switch on left side of the component box. ***If still in place, remove plastic cover.***
7. To increase sensitivity, slowly rotate the pressure switch adjustment dial to the right (clockwise) ... turn to the left (counter-clockwise) to decrease. Restart fryer & repeat **Step-2 thru 3**. As necessary, continue incremental adjustments until the burner(s) consistently shutdown when approx. half of the stack opening is blocked.

Shutdown fryer ... re-secure the control panel.

8. Drain water from the fryer into a suitable container (***NOT Filter Pan***). Proceed to **Section 2.11**.

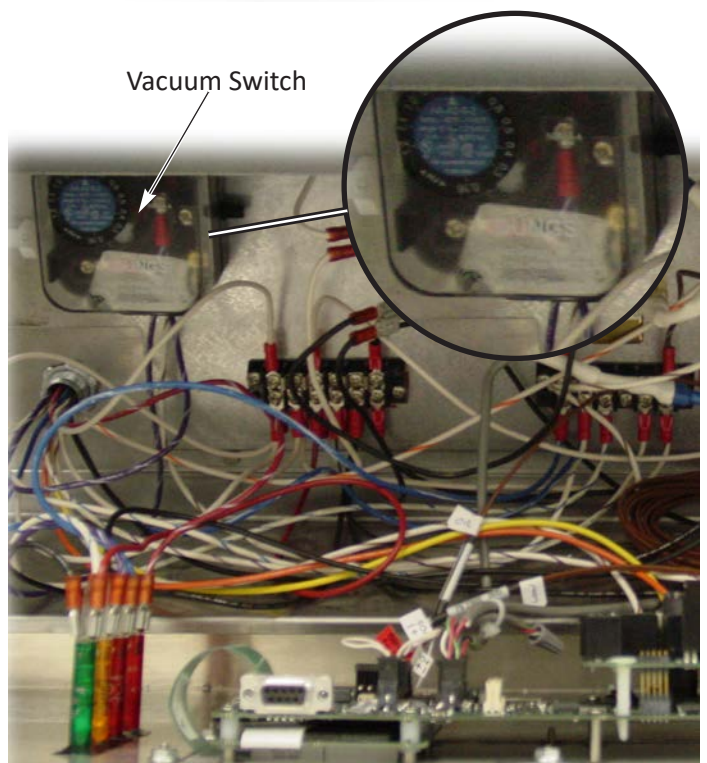

2.11 Restraint Device

This appliance requires use of a *restraint device (not provided)* to prevent it from being moved unintentionally, placing undue strain on electrical & gas connections. The restraint cable length must be shorter than both electrical cord & the flexible gas line and must be anchored to a immovable wall or structure. A quick-disconnect latch can be placed on one end of the cable so that it can be easily removed for servicing or cleaning. Proceed to [Section 2.12; Finalizing Installation](#).

* Restraint Anchor attached to non-movable wall

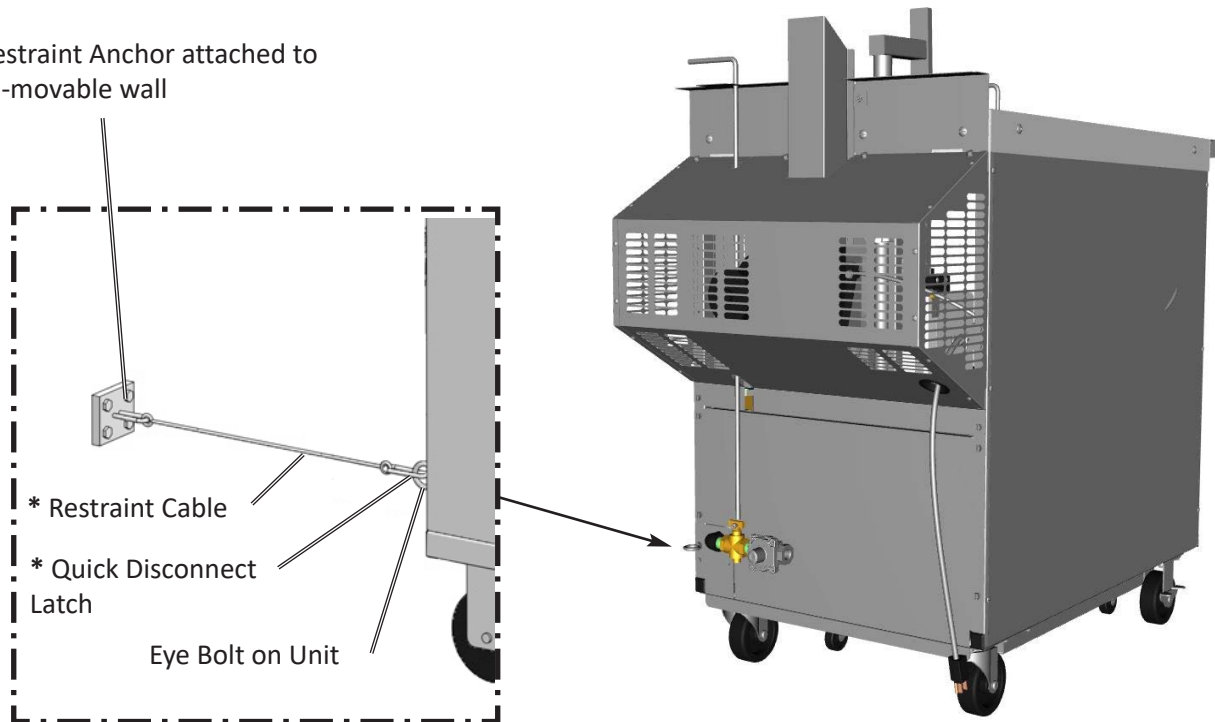

* Customer supplied

2.12 Finalizing Installation

Every effort is made to ensure that all new *GILES* food service equipment is in perfect operating condition when received & installed ... each unit has passed rigorous quality control testing & inspection prior to shipment. To ensure that it has been properly installed & will operate as expected when placed into service, we recommend that the following simple tests be performed to check basic functionality of systems & prepare the appliance for first use.

CAUTION

Before proceeding, please refer to [Section 3](#) to become familiar with various controls, systems & functions. After fully understanding this information, perform the following steps precisely to avoid possibly equipment damage.

2.12 Finalizing Installation - continued

BEFORE BEGINNING:

- As necessary, remove basket & filter pan from fryer.
- As applicable, on control panel set **POWER & SELECTOR** switches in the **[OFF]** positions.
- Inside cabinet, confirm that **DRAIN VALVE** is **[CLOSED]** & **OIL DIVERTER VALVE** is in **[TO FRYPOT]** position.
- If any of the following tests fail to produce the described result, consult **Section 7, Troubleshooting**, or contact **GILES Technical Service at 800.554.4537** for assistance.



2.12.1 Power Test

This test confirms that the unit is receiving power properly.

1. Confirm that circuit breakers supplying power are ON & fryer power cord is plugged into wall receptacle.
2. Place **POWER** switch in **[ON]** position. Green **POWER** light turns ON & the computer controller powers up. When alarm sounds after power-up & **"POWER FAILURE"** message appears on *upper controller display* ... press **[ALARM]** key to silence ... leave **POWER** switch **[ON]** and proceed to **Section 2.12.2**.

If the **POWER** light does not turn ON and/or controller does not power-up, refer to **Section 7.01, Troubleshooting Procedures**.



2.12.2 Burner Test

The following test will verify that gas burner system is receiving fuel & igniting properly.

⚠ WARNING

DO NOT touch the heat exchanger ring during this test. It becomes very hot ... bare skin contact will result in severe burn injury.

⚠ CAUTION

This test causes the burners to ignite & briefly burn without oil in pot. **DO NOT** allow burners to remain ON for more than **10 seconds**. Failure to observe this precaution may result in damage to the heat exchanger.

1. Be sure that main gas supply line valve is **OPEN** & that **fryer gas valve handle** is in the **[ON]** position.
2. Heat exchanger ring inside pot should be at room temperature. Wipe the ring with a soaked wet sponge, leaving visible moisture on its surface.
3. Place **SELECTOR** switch in the **[COOK]** position ... the draft fan should start & you should hear the ignitor sparking ... burners should light momentarily.

NOTE: If burner does not ignite within an allowed time, fryer will enter **FLAME FAIL** error. Return **SELECTOR** switch to **[OFF]** ... wait **10 seconds** & try again.



2.12.2 Burner Test - continued

4. After ignition, the surface of the heat exchanger should become hot & dry quickly (*within approximately 15 seconds*). Noticeable heat should be felt rising from the pot, indicating acceptable operation.
5. If burners do not light after two (2) attempts, or appear not to be heating properly, refer to **Section 7, Troubleshooting**.
6. If the burner system appears to be operational, return **SELECTOR** switch to [OFF] & proceed with the next test in **Section 2.12.3**.

2.12.3 Filter Pump Test

The following test will verify that the Filter Pump is operating correctly.

1. Place the **POWER** switch ① in the [ON] position.
2. Open cabinet door.
3. With the filter pan disconnected, place the palm of the hand tightly over the **filter pan hose quick-coupling** ② opening.
4. Briefly place the **SELECTOR** switch ③ in the [FILTER PUMP] position, then return to the centered [OFF] position. If suction is felt, when the pump ran, it is operating correctly; continue to **Section 2.12.4**.

If the pump does not run, no suction is felt, or air is blowing outward, refer to the **Section 7, Troubleshooting**.

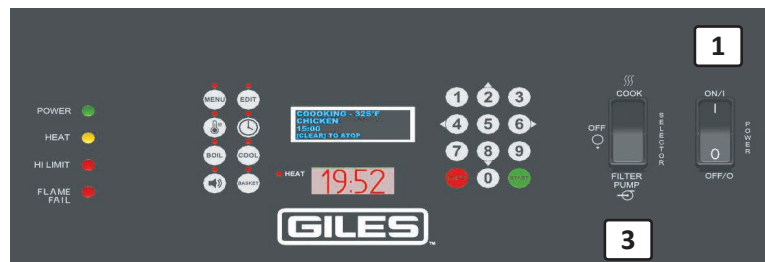

2.12.4 Pre-Use Fryer Cleaning

IMPORTANT!

Before using the appliance for the first time, perform a **Boil-Out** of the fryer pot. This process removes residue which may remain from manufacturing processes, or dirt & debris that may have accumulated during warehousing & shipment. For details concerning the *Boil-Out Procedure*, see [Section 5.1](#).

To remove residue which may remain from manufacturing processes, or dirt & debris that may have accumulated during warehousing & shipping, disassemble & thoroughly clean all parts of the filter pan. For details, see [Section 5.2, Cleaning the Filter Pan & Refreshing Filter Media](#).

Wash all accessory items included with the fryer (*basket, basket carrier arm, utensils, tools, etc*) in warm soapy water, rinse & allow to dry completely.

Inspect unit for remaining adhesive plastic protective film on sheet metal surfaces. Some film is typically left in place as added protection during storage & shipment. Remove all such material & clean the entire exterior of the unit with a good quality stainless steel cleaner/polish. **DO NOT use cleaners that are abrasive or contain caustic chemicals.**

2.12.5 Optional KITCHENTRAC® Remote Equipment Monitoring



If your new equipment is factory-equipped with **optional Giles' KITCHENTRAC®** remote monitoring, before it can be used the unit must be paired with your establishment's WiFi network and then connected to the **KITCHENTRAC®** server. Monthly user fees are required for the service.

A wireless router which is providing a continuous open connection to the internet and located within range of the monitored appliance is required for use of the service.

A detailed **WiFi Connection Manual (Form #66313)** should have been packed with the unit. Before the monitoring service is active, the steps outlined must be completed.

Once the connection process has been completed, you will be able to monitor appliance performance, productivity, menu trends, operational status, etc. and access available analytics by simply logging-in to the **KITCHENTRAC®** website from any computer or remote device (smart-phone, laptop, or tablet).

Installation is now complete and the appliance is ready for use. Before attempting to use it for the first time, please carefully read the remainder of this manual to become familiar with all controls, functions, procedures and necessary maintenance & cleaning activities. Adhering to the methods and processes described here will help keep your new **GILES** fryer performing flawlessly for many years.

3. Overview

The following section provides a brief overview of components, features & accessories of the *Giles GGF Series Gas Fryer*. Please review this section completely before attempting to use the appliance.

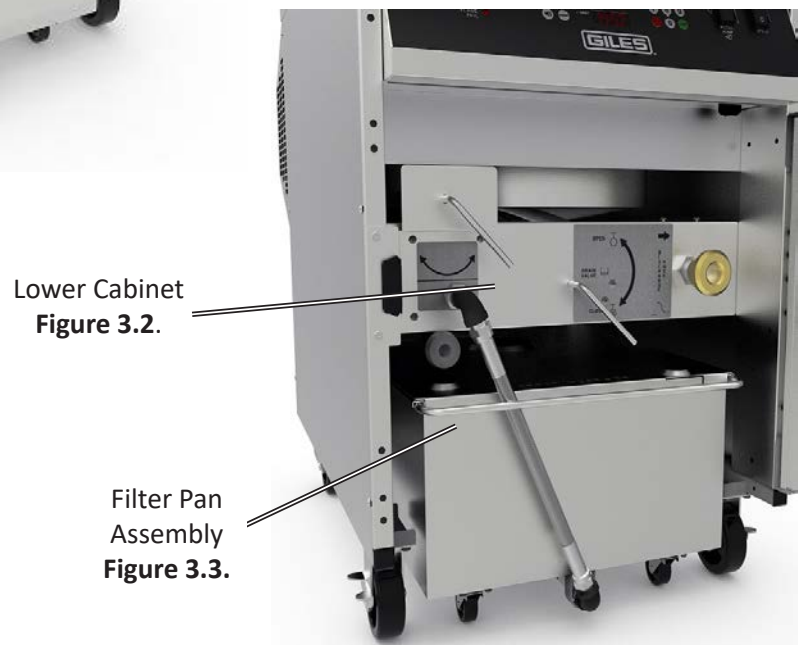

3.1 Control Panel

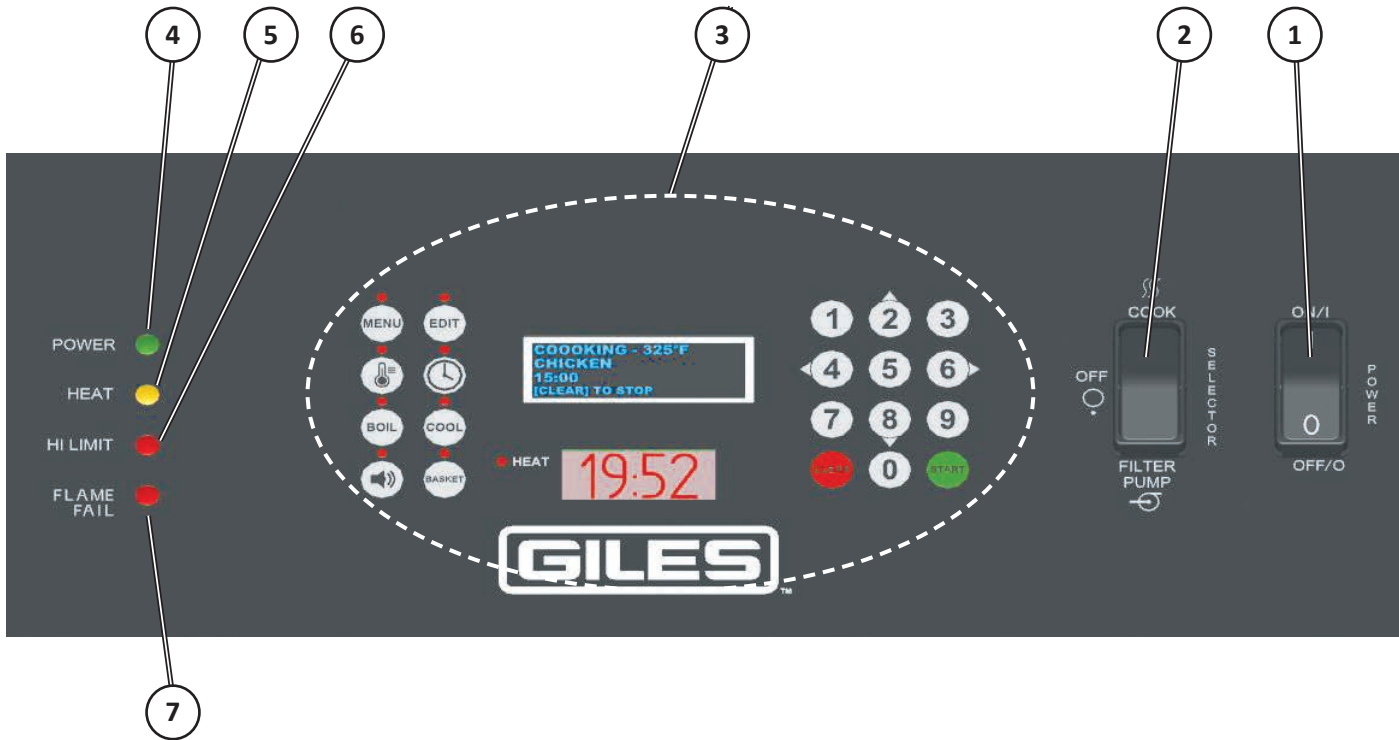

3.1 Control Panel

Item	Description	Function
1	POWER Switch	Turns fryer power ON/OFF. Press top portion to place in [ON] position for operation.
2	SELECTOR Switch	3-position switch selects fryer mode ... [COOK - OFF - FILTER PUMP] . Burners will only ignite & operate when in [COOK] position. Place in [FILTER PUMP] position to run filter pump. Centered position is [OFF] .
3	Computer Controller	Computer controller regulates cooking oil temperature & cooking time. Stores up to fifty (50), programmable menu item cooking presets. Continuously monitors fryer operation, displays alarm & error conditions and shows operational instruction prompts. Keypad used for inputting values & settings Function keys used to beginning specific controller functions.
4	POWER Light	Green light is ON whenever the POWER switch is in the [ON] position.
5	HEAT Light	Amber light illuminates when burners are ON. When set-point temperature is reached, the light turns OFF. Light cycles ON & OFF during normal operation as controller maintains oil temp.
6	HI-LIMIT Light	Red high-limit light illuminates when the overheat safety thermostat turns OFF power to gas valve, stopping flow to burners. Should this light come on, discontinue operation & refer to the <i>Troubleshooting Section</i> . <u>NEVER COOK IN A FRYER THAT CONTINUES TO GIVE A HI-LIMIT ALARM!</u>
7	FLAME FAIL Light	The red FLAME FAIL light illuminates whenever burner control system detects that there is not a flame present at the burner & the gas control valve has shutdown gas flow.

3.2 Lower Cabinet



3.2 Lower Cabinet

Item	Description	Function
1	Diverter Valve Handle	Directs filter pump discharge to either the fry pot or to the <i>Waste Oil Discharge Hose</i> .
2	Quick Coupling - Oil Discharge Hose	Connects the <i>Waste Oil Discharge Hose</i> to fryer plumbing when removing waste oil from fryer.
3	Drain Valve Handle	Operates the fry pot DRAIN VALVE . Always be sure that valve is closed prior to adding cooking oil or water for boil-out. <i>As a safety precaution, the burners will not ignite if valve is not completely CLOSED.</i>
4	Quick Coupling - Filter Pan Hose	Connects the Filter Pan Assembly to the fryer's on-board oil filtration system.
5	Filter Pan Assembly	Collects oil when drained from pot. Contains filter media for filtering & reconditioning cooking oil after use.
6	Filter Pan Cover	Helps minimize splash when hot oil is drained into the <i>filter pan</i> and helps safeguard against contamination of oil during the filtering process. Sits loosely atop filter pan & is easily removed for cleaning.
7	Cabinet Door	Provides access to lower fryer cabinet & filter pan. If needed, swing of the door is field reversible.
8	Door Magnet	Keeps door closed during operation

3.3 Filter Pan Assembly



* Non-standard; Sold separately; Not Included

3.3 Filter Pan Assembly

Item	Description	Function
*1	Crumb Screen	<i>*OPTIONAL, SOLD SEPARATELY, NOT INCLUDED</i> Designed to catch large crumbs, cooking offal & residue as oil drains into the Filter Pan.
2	Hold-Down Frame	Secures filter media tightly against Filter Pan bottom to provide a good pump suction seal. Improper placement will likely affect Filter Pump performance.
3	Filter Paper	Standard, disposable paper filter media. Filters fine sediment & residue from cooking oil during the filtering cycle.
4	Hold-Down Levers [4}	Secures hold-down frame firmly against the filter media in filter pan. If levers are not properly engaged, there is potential for poor filter pump performance.
5	Filter Pan Hose	Connects the filter pan to the fryer's oil filtration system. This hose must be disconnected before the filter pan can be removed.
6	Filter Pan	Collects used cooking oil for filtering; contains filter media which filters & reconditions oil during the filter cycle. The filter pan features casters ... it is easily removed for cleaning & refreshing filter media. Features a permanently attached perforated media support screen ... will help prevent large particle residue from entering the filter system should media be accidentally damaged. <i>THIS IS NOT A SUBSTITUTE FOR FILTER MEDIA ... MEDIA MUST BE USED!</i>
*7	Stainless Steel Woven-wire Mesh Filter Screen	<i>*OPTIONAL, SOLD SEPARATELY, NOT INCLUDED</i> A cleanable, sustainable, reuseable filter screen used as a direct substitute for standard paper media. Durable, can be used many times.

* Non-standard; Sold separately; Not Included

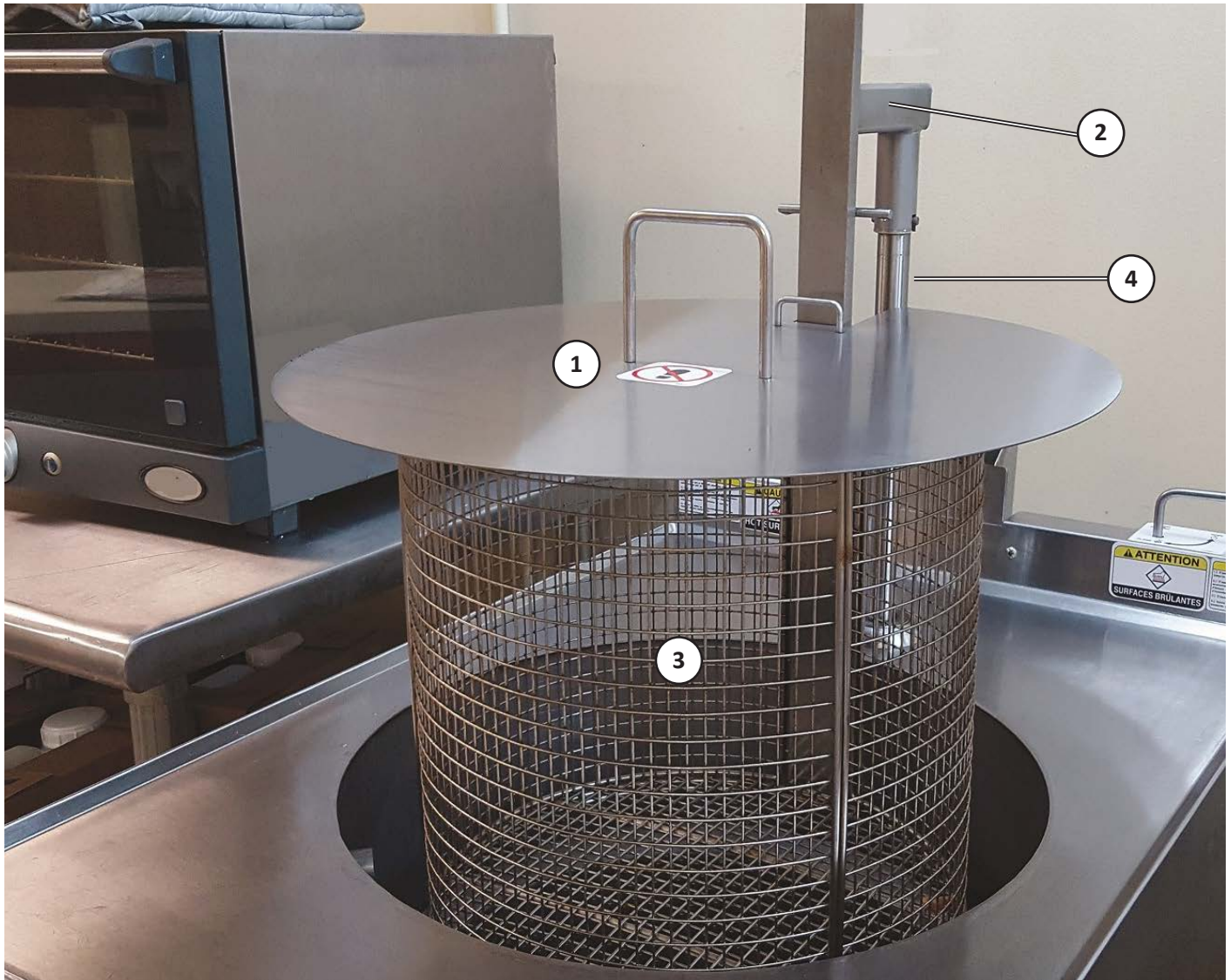

3.4 Basket & Optional Elevator Assembly



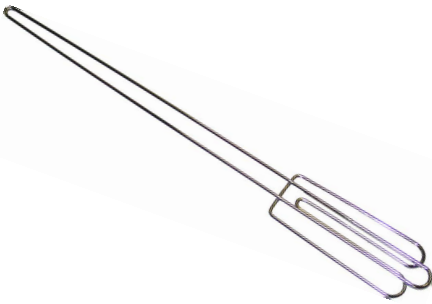

3.4 Basket & Optional Elevator Assembly

Item	Description	Function
1	Basket Cover	Covers pot during the cooking cycle & during idle periods. When in place will prevent hot cooking oil from splashing from the pot. Protects against contamination during idle times.
2	Basket Carrier Arm	Holds fry basket in a proper position as it is lowered & raised by the auto-basket lift.
3	Fry Basket	Contains product for cooking.
4	Auto-Basket Lift	Lowers basket into cooking oil, then automatically raises cooked product from the hot oil at end of cooking time.

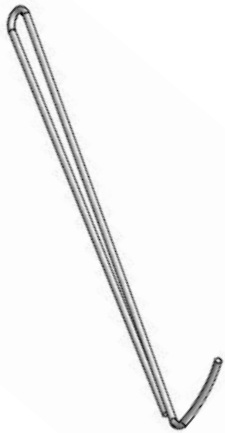

3.5 Accessories Included

Part	Description/Part Number	Function
	<p>Kettle Drain Brush P/N 71025</p>	<p>Heat Resistant brush for cleaning fryer vat drain & between the pot wall and heat exchanger wall.</p>
	<p>Stirring Utensil P/N 77775</p>	<p>Use to stir cooking oil & product in the vat as it is cooked to prevent sticking.</p>
	<p>Utility/Pot Brush P/N 71100</p>	<p>Heat-resistant brush for cleaning fry vat sides / bottom & surfaces of the heat exchanger.</p>
	<p>Crumb Scoop P/N 30059</p>	<p>Use to remove filter sediment from filter pan after filter cycle is complete.</p>

3.5 Accessories Included

Part	Description/Part Number	Function
	<p>Clean Out Tool (GGF 720 Only) P/N 80434</p>	<p>Use to clean between top and bottom heat exchanger tubes</p> <p><u>NOTE: THIS CLEAN OUT TOOL IS FOR USE WITH THE GGF 720 ONLY!</u></p>
	<p>Waste Oil Discharge Hose Assembly P/N 33667</p>	<p>Connects to fryer filter pump system. Used for removing waste cooking oil from fryer for disposal.</p> <p><u>NOTE: DO NOT USE TO WASH DOWN THE FRYER VAT!</u></p>

3.6 Accessories Not Included

Part	Description/Part Number	Function
	<p>Giles Filter Paper P/N 60810</p>	<p>Paper filter media place in filter pan for filtering cooking oil.</p>
	<p>Giles Filter Powder P/N 72004</p>	<p>Filter aid compound used when filtering cooking oil ... helps recondition oil by removing soluble fats & impurities.</p>
	<p>Giles Fryer Boil-Out P/N 72003 Case of (24) pre-measured 6-oz Packets</p>	<p>Fryer cleaner/degreaser ... add to water for a fryer boil-out cleaning procedure. Typical fryer requires (2) packets. Can also be used as an overnight cleaning soak. Also, ideal to clean tile & concrete floors.</p>

3.6 Accessories Not Included

Part	Description/Part Number	Function
	<p>Giles Oil Caddy P/N 79187</p>	<p>Portable waste oil disposal container with capacity for 80-lbs of waste oil.</p> <p>Intended to handle warm, clean, filtered oil ... no crumbs or debris.</p>
	<p>Tool Caddy P/N 71522</p>	<p>Tool storage rack that mounts directly to the fryer or a nearby wall.</p> <p>Does not include tools.</p>
	<p>Splash Guard (Left Side Shown)</p> <p>P/N 72084 (Left Side) P/N 72085 (Right Side)</p>	<p>Provides a side shield for the fryer vat to prevent oil splash & splatter from soiling adjacent equipment & floors.</p>
	<p>Filter Pan Crumb Catcher P/N 39246</p>	<p>Filter Pan insert helps prevent larger crumb particles & cooking debris from getting into the Filter Pan.</p>

4. Fryer Operation

This section describes operating procedures for *Giles Model GGF-400 & GGF-720 Gas Fryers*.

⚠ DANGER

- Turn **OFF** fryer **POWER** switch & disconnect supply power at main electrical panel, or remove power cord plug from wall receptacle before cleaning or servicing.
- **DO NOT** wash down with water from a spray hose, or pressure washing equipment.
- **DO NOT** operate gas fueled appliances in enclosed spaces without providing proper ventilation & effective venting of combustion gases to the outside.
- Failure to comply with **DANGER** notices will result in serious injury, even death, damage to equipment or property and void the factory warranty.

⚠ WARNING

- **DO NOT** use or store flammable liquids, or materials that produce flammable vapors, in the vicinity of this or any other appliance!
- **DO NOT (or ALLOW OTHERS to) stand or step onto the top of the fryer for any reason.** Very serious injury can result from slips & falls, or from bodily contact with extremely **HOT** cooking oil in the cooking pot (**excess of 330°F/166°C**). Removable covers placed over cooking vats & pots are **NOT designed to, and WILL NOT, support the weight of a person.** 
- Failure to comply with **WARNING** notices could result in serious injury, even death; damage to equipment and/or property and will void the factory warranty.

⚠ CAUTION

- Be sure the fryer is positioned in a stable, safe location with front caster wheel brakes locked.
- Exercise caution when operating & cleaning. **To avoid personal injury, wear thermal protection (gloves or mitts) while tending the appliance.** Certain parts of fryer can become very **HOT** during operation; temperatures inside the cabinet may exceed **150°F/65.5°C and cooking oil temperature is in excess of 330°F/166°C.**
- This appliance is for professional use only and is to be operated by qualified personnel. It is not intended for use by persons (including children) with reduced physical, sensory, or mental capabilities, or those lacking experience and knowledge, unless they have been given adequate instruction and/or supervision concerning its operation by a person responsible for their safety.

4.1 Computer Cooking Controller

This section explains the functions, features & operational procedures for the *dual-timer Computer Controller*. The controller has been designed to be user-friendly & many operational instructions & prompts will be shown on the *upper display screen* (blue graphic) to help guide you through each process.



4.1.1 Keypad & Function Keys



Numeric Keypad: Use to enter fryer setting values and to create/edit *Menu Item cooking presets*.

Arrow Keys: The [2] • [4] • [6] • [8] keys are used as directional keys for manually operating the basket lift, scrolling through lists, moving the cursor, etc: [2]=UP, [8]=DOWN, [4]=LEFT, [6]=RIGHT. When active as **arrow keys**, each will be illuminated.

[START]: A function key used for various operations ... start cook cycles, select items, save settings, etc.

[CLEAR]: A function key used to cancel cook cycles, exit functions, etc.

4.1.1 Keypad & Function Keys - continued



MENU Key: Action key which is pressed in combination with other keys to access programmed menu item presets. Up to fifty (50) different programmable presets can be created & stored.



EDIT Key: Action key which is pressed in combination with other keys to enter *edit mode* for changing or entering new *Menu Item preset* cook settings.



TEMP Key: Press this key to input a cooking oil temperature setpoint. When fryer is in **READY** state, pressing key twice (2x) will display *actual oil temperature* on the *lower display screen* for approximately **20 secs**. **NOTE:** During **PREHEAT**, the real-time actual temperature is displayed.



CLOCK Key: Press this key to begin manually inputting a cooking time (mm:ss).



While in **PREHEAT** state, press this key to start the **BOIL-OUT** program. Temp setpoint & time will change to the **BOIL TEMP** and **BOIL OUT TIME** specified in Controller User Settings, Section 4.1.7, Edit User Settings. **Defaults = 200°F & 30 mins**.



Press this key to enter **COOL** mode. An energy-saving feature that puts fryer at a lower temperature during inactive periods. Temp setpoint will change to the **COOL TEMP** specified in Controller User Settings, Section 4.1.7, Edit User Settings. **Default = 275°F**.



ALARM Key: Pressing this key silences the controller alarm & acknowledges certain message prompts. Alarm tone will silence automatically after a preset duration ... **Default = 10 secs**.



BASKET Key: Activates the arrow keys **[2] UP** & **[8] DOWN** for manually operating the automatic basket lift. Key is **disabled** during **PREHEAT** mode to prevent lowering product into oil that is not yet at the proper cooking temperature.



Upper OLED Display (blue graphic): Displays cook settings, fryer status information, operational instruction prompts, alarm/error messages, etc..



Lower 7-Segment Display (red graphic): Displays status information, cook cycle time countdown, temperature, error codes, etc.

[HEAT] indicator illuminates when controller signals for burners to ignite for heating. Burners will not actually ignite unless control panel **SELECTOR** switch is in the **[COOK]** position.

4.1.2 Controller - General Overview

The following is only a general overview ... detailed procedures & instructions are covered in subsequent sections. During operation, certain instructions & prompts are shown on the *upper controller display* to help guide you through processes. Additionally, some controller keys & indicator lights will illuminate as a further aid.

- **POWER UP:**

When **POWER** switch is placed in the **[ON]** position, controller will power up & sound an alarm. The message **“POWER FAILURE [PRESS START TO PREHEAT]”** is shown on the *upper display screen*. ***This is normal***, intended to prevent the fryer from beginning to heat after power interruptions without an operator present. Pressing the **[START]** key silences the alarm & places fryer into **PREHEAT** mode. If the control panel **SELECTOR** switch is in the **[COOK]** position, and controller temp setpoint is higher than current actual oil temperature, the burners will ignite & cooking oil will begin heating. ***DO NOT place SELECTOR switch in [COOK] position unless pot is filled to the FULL level with cooking oil (or water).***

- **PREHEAT:**

While the oil is heating during **PREHEAT**, the real-time actual oil temperature is displayed on the *lower display screen*. When oil reaches the programmed setpoint, alarm will sound & *upper display* shows the message **“ALARM - STIR OIL”**. Press the **[ALARM]** key, then vigorously stir the heated oil. Typically, oil temp drops when stirred ... controller delays *10 seconds* & if temperature drops below setpoint when stirred, **PREHEAT** continues until temp returns to the setpoint. ***This process will help to ensure more consistent temperature throughout the total volume of oil, which leads to better cooking performance.*** Upon reaching setpoint again, alarm sounds & *upper display* reads **“ALARM - SETPOINT REACHED”**. Press the **[ALARM]** key to silence & place fryer into **READY** state.

- **READY STATE:**

Oil is at cooking temperature & fryer is ready to cook. The *lower display screen* changes to show the current controller temperature setpoint & *upper screen* will display the last cook settings used.

You may revise the fryer cook settings while in **PREHEAT** or **READY** state ... select a different menu item preset, see **Section 4.1.4.2, Selecting a Menu Preset** to change cook temp, time & food name - **OR** - manually enter different settings, see **Section 4.1.3, Setting a Manual Temperature & Cook Time**.

NOTE: If the controller parameter “PASSCODE ENABLE” is set to [ON], you must enter a password before you are able to manually enter a cook time or temp. This is a security feature to provide management control over cooking procedures.

- **START:**

Current cook settings (*preset or manual*), are shown on the *upper display*. To start the displayed cooking cycle press the **[START]** key. When started, cooking time count down begins & is displayed on the *lower display screen*.



4.1.3 Setting the Cooking Temperature



Before setting temperature, be sure the **SELECTOR** switch is in the **[OFF]** position & that pot is filled with cooking oil.

NOTE: When using a manually entered *cook time* and/or *temperature*, the *upper display* shows the label **[MANUAL]** instead of a *Menu Food Item* name.



IMPORTANT!

If the **PASSCODE** feature is enabled, *time & temperature* settings **cannot** be manually entered without the required password. You will only be able to choose from the available programmed *Menu Item Presets*, see **Section 4.1.4, Working with Menus**.

Set Cook Time: (mm:ss)



Press the **[CLOCK]** key



Use keypad to enter cook time (mm:ss).
Ex: 1530 = 15:30



Press the **[START]** key to save setting.

Set Cook Temperature: (°F)



Press the **[TEMP]** key



Use keypad to enter cooking temperature set-point (°F).
Ex: 325 = 325°F



Press the **[START]** key to save setting.

NOTE:

Pressing **[TEMP]** key twice (2x) will display actual oil temperature on *lower screen* for 20 seconds



DO NOT place **SELECTOR** switch in the **[COOK]** position unless vat is filled to the **[FULL]** level with cooking oil (or water) & you are ready to start heating.

- If actual oil temperature is lower than entered setpoint, controller enters **PREHEAT** (small red **[HEAT]** indicator light on controller turns **ON**). Oil **will not** actually begin heating until the control panel **SELECTOR** switch is placed in the **[COOK]** position ... amber control panel **HEAT** indicator light will turn **ON** & heating begins.
- If oil temperature is already equal to or greater than entered setpoint, an alarm sounds & the message **"STIR OIL"** is displayed on *upper screen*. Press the **[ALARM]** key & stir oil. Continue to stir oil until alarm sounds again & message **"SETPOINT REACHED"** is displayed ... stirring may cause a temp drop, fryer returns to **PREHEAT** & heat comes **ON** until temp reaches setpoint again. Press **[ALARM]** key ... controller enters **READY** state ... fryer is ready to cook.

While heating, the **real-time actual oil temperature** is shown on the *lower display screen*. After setpoint is reached, this display will change to show the **temperature setpoint** ... press **[TEMP]** key twice to display actual oil temp.

4.1.4 Working with Menu Item Presets

Fifty (50) different *Menu Item Preset* cook settings can be stored in the controller, each includes:

- **Menu #** - Sequential ID number
- **Menu Name** - Name of the food product assigned to the preset.
- **Cooking Time** - Cook time setting for the item.
- **Cooking Temperature** - Cooking oil temperature setting for the item.
- **STIR OVERRIDE** - *ONLY* for this menu item, can change how the controller **STIR ALARM** parameter that is set in *User Settings* will act. **Factory default = [NORMAL]**.
- **FISH FILTER** - *ONLY* for this menu item, can change how the controller **FORCE FILTER** parameter that is set in *User Settings* will act. To control flavor transfer, establishments cooking seafood may wish to force oil filtering after cooking only **one (1) batch** of seafood product. **Factory default = [OFF]**. A **SNOOZE** feature is available which will allow cooking **two (2) batches** of the product before forced filter.

All of the *Menu Presets* are factory-programmed with default settings. The first ten (10) are set for some popular typical menu items (*names & settings shown in table below*). The general settings as shown on the last line are stored in all others. As needed, you can edit any of these settings to customize for your specific applications and menus.

Instructions for creating & working with **Menu Item Presets** are covered in the following sections.

MENU NO.	MENU NAME	TEMP (F°)	TIME (MM:SS)	STIR OVERRIDE	FISH FILTER
1	BONE-IN-CHICKEN	335°	13:00	NORMAL	OFF
2	TENDERS	335°	7:00	NORMAL	OFF
3	WEDGES	335°	6:00	NORMAL	OFF
4	BONE-IN-WINGS	335°	8:00	NORMAL	OFF
5	BONELESS WINGS	335°	7:00	NORMAL	OFF
6	POPCORN CHICKEN	335°	3:00	NORMAL	OFF
7	LIVERS	335°	4:00	NORMAL	OFF
8	CORNDOGS	335°	10:00	NORMAL	OFF
9	CHEESE STICKS	335°	3:00	NORMAL	OFF
10	FISH	335°	3:00	NORMAL	OFF
11 thru 50	MENU XX	335°	2:00	NORMAL	OFF

NOTE:

Some customers have arranged for purchased fryers to be preloaded with their own specific Menu Set. If that is the case, the first 10 menu items will be different than those shown above.

4.1.4.1 Editing a Menu Preset

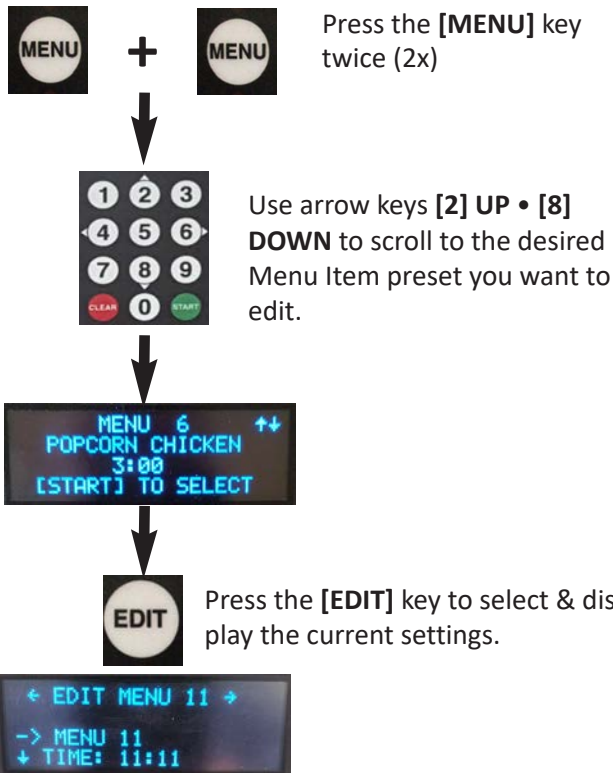

Use arrow keys [2] / [8] to move the cursor [-->] until it points to the preset item you wish to edit:

- NAME
- TIME
- TEMP
- > STIR
- FISH FILTER

When editing **NAME**, **TIME** or **TEMP**, press [START] key to select ... when cursor points to **STIR** or **FISH**, pressing [START] toggles between setting choices.

Press the [START] key to begin ...



Edit NAME: *Two methods available*

Method 1

Enter NAME letter by letter



Choose **NAME** to edit as described at the left. A flashing cursor appears at under first letter of the current name. Use arrow keys [2] / [8] to scroll thru alphabet ... the character at cursor changes ... stop on the desired letter. Press right arrow key [6>] to move cursor to next character in the **name** ... repeat until item name is complete.



When finished editing, press [START] to save

- OR -

Press [CLEAR] to **Cancel & Exit** without saving



Use left arrow key [<4] to backspace & erase errors.

Method 2

Select a NAME from catalog of programmed names.



Choose **NAME** to edit as previously described. Cursor appears under first letter. Press [0] key to open a **catalog** of **programmed names** ... use arrow keys [2] / [8] to scroll through list. Stop at desired name ... press [START] to copy & paste the selected name ... previous display returns.



When finished, press [START] to save - OR - Press [CLEAR] to **Cancel & Exit** without saving - OR - Press [0] to re-open the **name catalog**.

4.1.4.1 Editing a Menu Item Preset - continued

Edit COOKING TIME:

Scroll to & select TIME for editing as shown previously.



Current time setting is displayed.
Use numeric keypad to enter the new TIME (mm:ss)



NOTE: All digits must be entered, e.g. 1000 = 10:00, 105 = 1:05
Press the [CLEAR] key to backspace to erase errors.



After entering new value, press [START] to save
- OR -
Press CLEAR to exit without saving



Edit COOKING TEMPERATURE:

Scroll to and select TEMP for editing as shown previously.



Current temp setting is displayed. Use keypad to enter new cooking TEMP setpoint (°F). 335 = 335°F
Max = 350°F



Press the [CLEAR] key to backspace to erase errors.

NOTE: Temperature unit can be changed to [°C] in User Settings, see Section 4.1.7



After entering new value, press [START] to save
- OR -
Press CLEAR to exit without saving



4.1.4.1 Editing a Menu Item Preset - continued

Edit STIR OVERRIDE Setting:

Regardless of the controller **[STIR ALARM]** setting in *user settings* (Section 4.1.7), you may wish to have certain items ***stirred -OR- not stirred*** during the cook cycle. The **STIR OVERRIDE** setting will override the controller setting for this specific item only.

Available settings: **[NORMAL]** • **[SKIP]** • **[FORCE]**.

[NORMAL]: The alarm is issued as specified in controller *user settings*.

[SKIP]: The alarm is ***NOT*** issued for this item, regardless of the controller setting.

[FORCE]: The alarm is ***ALWAYS*** issued for this item, regardless of controller setting.

Factory-default: **[NORMAL]**

 To edit setting, scroll to & select setting as described previously ... → pointing to **[STIR]**

Press the **[START]** key to toggle between the available options, stop at desired setting & it is saved.

Edit FISH FILTER Setting:

To minimize potential for flavor transfer, establishments that cook seafood along with other items in the same fryer, may wish to force associates to filter fryer oil after cooking ***only one (1) batch*** of seafood.

When **[FISH FILTER]** is set to **[ON]**, the fryer will enter forced **FILTER MODE** after cooking one load this specific item. If **[FORCE FILTER SNOOZE]** is set to **ON** in *user settings* (Section 4-1.7), one additional load is allowed before filtering is forced ... the fryer will then be locked out of continued operation until the filtering cycle is completed.

When **[FORCE FILTER]** is **OFF**, only a *filter warning message* will be displayed on the *upper controller screen* ... it will continue to display after each subsequent load until filtering cycle is performed.

To edit, scroll to & select this setting as described previously ... → pointing to **[FISH FLTR]**

 Press the **[START]** key to toggle between the selections, stop at desired setting & it is saved.

4.1.4.2 Selecting a Menu Preset for Cooking

CAUTION Before selecting the preset, be sure that the control panel SELECTOR switch is in the [OFF] position & that the pot is properly filled with cooking oil.

A. Direct Entry Method - desired Menu is known.

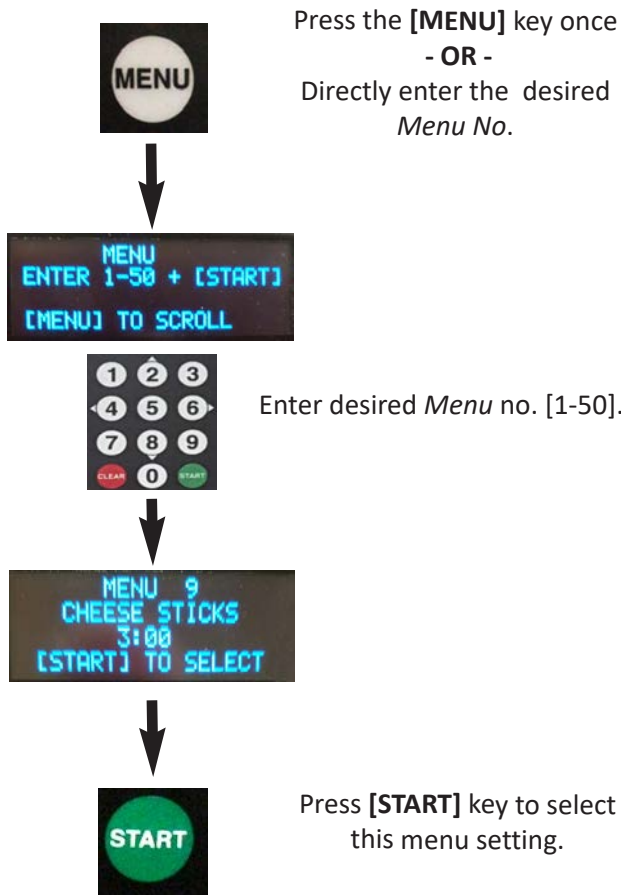

B. Scroll Method - Scroll through list of Menu Presets & view settings on the upper display screen.

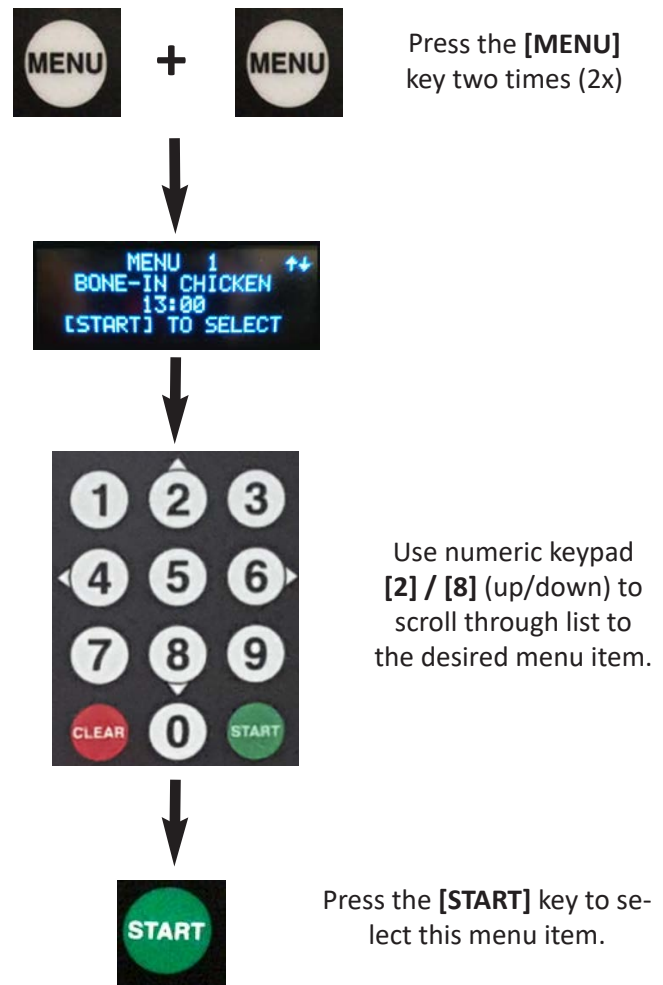

Selected menu Item preset cooking information is shown on the upper display screen.
After selecting, place control panel SELECTOR switch in [COOK] position.

If actual oil temperature is lower than the temperature setpoint specified by the selected preset & **SELECTOR switch is in the [COOK] position**, heating elements turn ON & oil begins heating. If actual temperature happens to be higher than controller setpoint, the "SETPOINT REACHED" alarm sounds ... pressing the [ALARM] key will immediately place the fryer into READY state ... cooking may begin.

NOTE:
The automatic basket lift is disabled while fryer is in PREHEAT mode ... will be enabled when setpoint is reached & fryer enters READY state.

4.1.5 Cooking Cycle - General Overview



COOKING TEMPERATURE • MENU NAME • COOK TIME • STIR OVERRIDE & FISH FILTER settings are shown on the *upper display screen*. The **READY** prompt indicates that cooking oil is at cooking temperature & fryer is ready to cook.



When fryer is in **READY** state the **TEMP** setpoint is displayed on the *lower screen*.

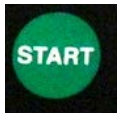

To start the cook cycle, press the **[START]** key once. Basket will automatically lower into the cooking oil & cook **TIME** will begin counting down on the *lower display*.

STIR ALARM: If this setting is set up as **ON**, an alarm sounds at a specified time during the cook cycle to signal operator to stir the cooking product. Stirring helps to promote even doneness & prevent pieces from sticking together. The feature is enabled & the parameters set in *User Settings, Section 4.1.7*. **[STIR ALARM %]** is the amount of cooking time which must elapse before the alarm ... for example, if set at **60**, then during a **10 min.** cooking cycle, the alarm will sound after product has cooked for **6 mins.**

Factory-set defaults: **[STIR ALARM ENABLE] = ON ... [STIR ALARM %] = 62.**

The menu item **STIR OVERRIDE** setting can override the setting, see *Section 4.1.4.1*.

When cooking cycle time is complete, an alarm will sound & the message **“DONE COOKING”** is displayed on the *upper screen*. The cook basket is automatically raised from the pot. Press the **[ALARM]** key to silence alarm ... fryer returns to **READY** state, awaiting the next load of product.

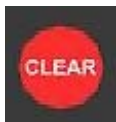

x 2

To cancel a running cook cycle press the **[CLEAR]** key once, then press it again to cancel **-OR-** press **[<4]** to continue the cook cycle.

4.1.6 Other Controller Features

4.1.6.1 Manually Operating the Basket Lift



- OR -



Press the **[BASKET]** key once

Use **[2] UP** & **[8] DOWN** keys to raise or lower the lift

NOTE:

- Manual lift operation is disabled while the controller is in **PREHEAT** mode as a safeguard against placing product into oil that is not yet at the proper cooking temperature.
- Once activated, the lift cannot be manually actuated again for approximately **20 secs.** or until the red indicator over the **[BASKET]** key turns OFF.

4.1.6.2 Cool Mode



COOL mode is an energy-saving feature that lowers oil temp setpoint value, placing fryer into a standby mode during periods of inactivity. Can help slow oil oxidation, extend oil durability & life.

Press the [COOL] key once to enter **COOL** mode. Temperature setpoint changes to the **COOL TEMP** setting specified in *user settings*, see [Section 4.1.7](#).

Factory-set default is 275°F ... setting range is between 200° & 350°F.

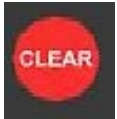

+



To exit **COOL** mode, press the [CLEAR] key, then press [<4] to exit

- OR -

Press [CLEAR] again to continue **COOL** mode.

Upon exit, temperature setpoint returns to the previous active value & fryer will enter **PREHEAT** until cooking temperature is reached.

4.1.6.3 Auto-Cool

When the **AUTO-COOL** feature is **ON**, fryer automatically enters **COOL** mode when **no cook cycles are started** within the amount of time specified by the [AUTOCOOL TIME] setting in *user settings*, see [Section 4.1.7, Edit User Settings](#).

Factory-set default: [AUTOCOOL] = OFF ... [AUTOCOOL TIME] = 30 ... setting range is 1 to 510 mins.

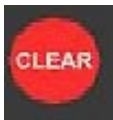

+



Exit **AUTO-COOL** same as **COOL** ... press the [CLEAR] key, then press [<4] to exit

- OR -

Press [CLEAR] again to continue **COOL** mode.

Upon exit, the temperature setpoint will return to the previous active value and fryer will enter **PREHEAT** mode until temperature is reached. The **STIR OIL** alarm is issued when setpoint is reached, as described in [Section 4.1.5](#).

4.1.6.4 Boil Out Program



Pressing the [BOIL] key while controller is in **PREHEAT** begins the **BOIL OUT** program.

Temperature and time change to the **BOIL TEMP** and **BOIL OUT TIME**, respectively, as specified in *user settings*, see [Section 5.1.7](#).

Factory-Default Setting:

BOIL TEMP is 200°F ... setting range is 185° to 208°F.

BOIL OUT TIME is 30 minutes ... setting range is 1 to 45 mins.

IMPORTANT!

After the BOIL OUT program completes, the controller enters an IDLE state. Pressing the START key recalls the previous menu item temperature setting ... fryer will go into PREHEAT. DO NOT press START until you are ready to continue using fryer, it has been properly drained, rinsed, pot filled with fresh oil & prepared for cooking ... see [Section 5, Cleaning](#).

4.1.7 Controller User Settings

User Settings can be accessed & edited by following these steps ...

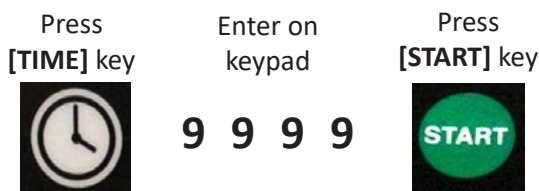

The table below describes *User Settings* & shows the *factory-set defaults*.

Use keypad [**<4**] & [**6>**] keys (left/right) to scroll through the list of *user settings* ... current setting value will be shown on the *upper controller display*.



- Press the [**EDIT**] key when desired setting is displayed.
- Use keypad [**2**] & [**8**] keys (up/down) to change the setting to your desired value.
- Press [**EDIT**] key again to **SAVE** choice.

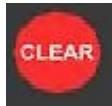

To exit *User Settings* menu, press the [**CLEAR**] key.

NOTE:
A message "**TOO LOW**" or "**TOO HIGH**" is displayed if an entered value is outside of the allowable range, which will cause a controller error.

NAME	DESCRIPTION	RANGE	DEFAULT
TEMP SCALE	Temperature unit of measure	°F or °C	°F
FORCE FILTER	When ON , forces operators to filter oil after the number of cook cycles set by FILTER COUNT are completed ... locks-out fryer until filtering complete.	ON - OFF	ON
FORCE FILTER SNOOZE	When ON , allows (1) additional cook cycle after FILTER COUNT is exceeded ... only active when FORCE FILTER is ON .	ON -OFF	OFF
FILTER COUNT	Number of cook cycles before oil filtering is FORCED.	1 to 20	4
GUARD BAND	Cooking not allowed if oil temperature deviates from the set-point by amount of guard band	1 to 990	900
MAX SETPOINT	Maximum oil setpoint allowed by controller.	32°F to 375°F	350°
AUTOCOOL	After a specified amount of time, unit will enter COOL mode.	ON - OFF	OFF
AUTOCOOL TIME (MINUTES)	When AUTOCOOL is ON , fryer automatically enters COOL mode after unit is idle for this amount of time.	1 to 510 minutes	30
AUDIBLE ALARM (SECONDS)	Duration of the audible alarm in seconds ... automatically silences after this amount of time.	5 to 120 seconds	10
COOL TEMP	Temperature setting for the COOL mode	200°F to 350°F	275°F
BOIL TEMP	Temperature setting for the BOIL OUT cycle	185°F to 208°F	200°F
FILTER RESET	The temperature that resets/unlocks fryer from FILTER MODE .	200°F to 325°F	290°F
BOIL OUT TIME	Time (in minutes) for the BOIL OUT cleaning cycle	1 to 45 minutes	30
STIR ALARM ENABLE	When ON , sounds the STIR ALARM at specified % of cook cycle completion.	ON - OFF	ON
STIR ALARM %	When STIR ALARM is ON , the alarm sounds after this percent [%] of programmed cooking time has elapsed.	10% to 90%	62%
KEY BEEP ENABLE	When ON , an audible sound is generated by each keystroke.	ON - OFF	OFF

4.1.7 Controller User Settings - continued

NAME	DESCRIPTION	RANGE	DEFAULT
LANGUAGE	Sets the controller's display language	English-Spanish-French	English
[0] KEY EXTRA TIME	When ON , operator can add extra cooking time (<i>after or during the cycle</i>) by pressing [0] key + number of mins to add .	ON - OFF	OFF

4.1.8 Password Protection

It is possible to add **PASSWORD** protection for certain controller settings. This feature is a **FACTORY SETTING** that is typically *DISABLED*. If **PASSCODE ENABLE** is set to **[ON]**, you will be prompted to enter a password before performing many controller operations.

If you desire to have password protection enabled, or have questions concerning this feature, call **Giles Technical Services at 800.554.4537** to request the passcode & instructions as to how to enable the feature.

4.1.9 Start-Up Procedure

1. Be sure that the **SELECTOR** switch ① is in the center **[OFF]** position.
2. Place **POWER** switch ② in the **[ON]** position & green **POWER** light ③ will come **ON**. The computer controller powers-up & the sounds an alarm. The message "**POWER FAILURE [PRESS START TO PREHEAT]**" is shown on the upper display screen ④. ***This is normal ...***

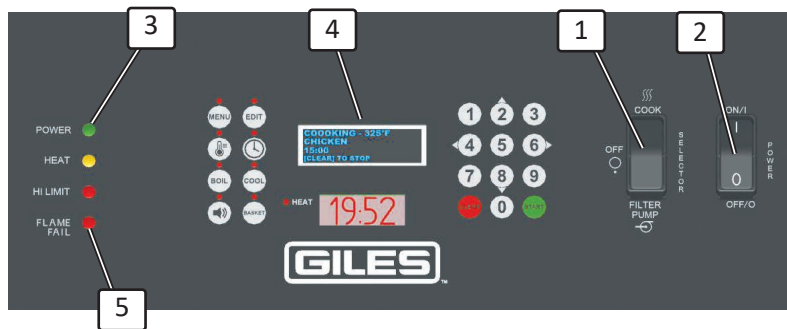

occurs each time fryer power is cycled **OFF & ON**. The purpose is to prevent fryer from beginning to heat after a loss of power until it can be attended by an operator. Pressing the **[START]** key silences the alarm & places fryer into **PREHEAT** mode. Fryer settings displayed on the *upper screen* are the last used. The red **HEAT** indicator beside the *lower display* indicates that controller is signaling for heat, but until **SELECTOR** switch is placed in **[COOK]** position, the burners will not ignite for heating.



DO NOT place switch to **[COOK]** position unless pot is filled with cooking oil (or water), see *Section 4-2, Cooking Procedures*.

3. **IF POT IS FILLED**, place the **SELECTOR** switch ① to the **[COOK]** position. The draft blower starts running & you should hear burners ignite. If there is no ignition after a specified amount of time, the red **FLAME FAIL** light ⑤ will turn **ON** and the fryer gas control valve closes. When this occurs, return **SELECTOR** switch to **[OFF]**, wait 2 -3 minutes to allow accumulated gas to dissipate and then try again.

IMPORTANT! If the appliance continues failing to ignite, refer to **Section 6, Troubleshooting**. A service technician may be required to correct certain issues.

4.1.10 Controller Errors & Alarms

Conditions that can cause unsafe operation or result in damage to the appliance (*open valves, low oil level, high temp, etc.*) will stop operation, activate an alarm tone & display error codes/messages. Error codes are shown on the lower **7-Segment Display** ... error messages & prompts are shown on the upper **OLED Display**. Generally, burners are shutdown & gas supply is turned **OFF** until error conditions have been corrected. Pressing the **[ALARM]** key silences the alarm, but will not clear an error. Error codes are shown in the Table below ... further details are discussed in the following section.

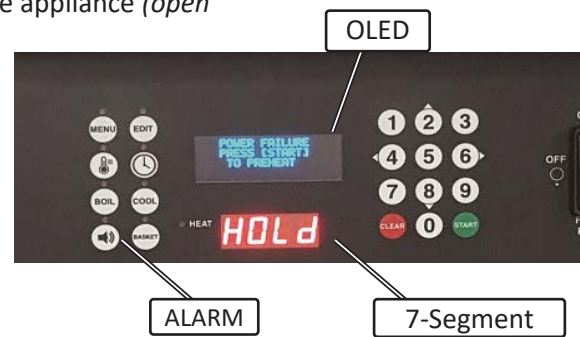

ERROR CODE	DESCRIPTION (<i>Upper Display</i>)	PROBLEM
OPEN	DRAIN IS OPEN	Drain valve is open, or not completely closed. If cooking, the basket will be raised.
----	CHECK OIL LEVEL, ENSURE VAT IS FULL, IF FULL THEN PRESS [START]	This is a notification to confirm oil level that is displayed after the OPEN drain error has been cleared.
ER03	LOW OIL LEVEL – ENSURE VAT IS FULL (Element/Add Level Differential Warning)	The oil level is below the [ADD] level in the vat. Add oil to the [FULL] level mark & stir.
ER06	LOW OIL LEVEL – ENSURE VAT IS FULL – PRESS [START] (Post ER03 Warning)	After an ER03 is cleared, this notification is displayed until operator presses [START] to confirm oil level.
ER07	MAX ELEMENT TEMP – PRESS [START] (Post Warning)	Error is displayed after a MAX element temperature (ER19) has occurred & element has cooled below MAX temp.
ER13	OIL PROBE Error	Problem with the <i>variable oil temp probe</i> . Call for service is generally required.
ER15	ELEMENT PROBE Error	Problem with <i>element temp probe</i> , attached directly to heating element. Call for service is generally required.
ER17	ADD LEVEL PROBE Error	Problem with <i>add level probe</i> at pot [ADD] level. Fryer without this probe should have the ELMT-ADD DIFF ENABLE setting [OFF] in Factory Settings . Probe cannot be bypassed. Call for service is generally required.
ER19	MAX ELEMENT TEMP Error	The maximum heating element temperature has been exceeded. This is a safety device; NEVER bypass this probe.
ER25	GUARD BAND EXCEEDED	Actual oil temperature deviates from setpoint by the Guard Band amount. Allow oil to cool, or heat, to within range. Factory default is 900°F ... Error should not occur.
ER37	EEPROM Error	An error occurred while saving settings to the EEPROM. Contact Giles Tech Service (800.554.4537).
ER38	Internal ADC Error	The ADC (Analog-to-Digital Converter) chip has stopped working. MCB1 board must be replaced. Contact Giles Tech Service (800.554.4537).

4.1.10.1 Resolving Controller Errors & Alarms

The following summaries explain various controller errors/alarms & some basic steps which can be taken to resolve them for returning to normal operation. Not being able to resolve an error/alarm by following these steps may indicate a more serious malfunction, which will require the attention of a qualified service technician.

- **DRAIN OPEN (Error Code OPEN)** - If the pot drain valve is opened (*even slightly*) while fryer power is **ON**, an alarm sounds, *lower display* reads “**OPEN**” & *upper display* reads “**ERROR ALARM - DRAIN IS OPEN**”. If cooking, the basket lift will be raised. Heating is shutdown & remains **OFF** until condition is cleared.

Press the **[ALARM]** key to silence alarm. Confirm the *drain valve* is closed completely, to clear alarm. When error is cleared, alarm sounds again & *upper display* reads “**CHECK OIL LEVEL, ENSURE VAT IS FULL, IF FULL THEN PRESS [START]**”. This is a post-error notification, alerting operator to confirm that no oil has been lost & is still at **[FULL]** level. If needed, add oil then press **[START]** key to return to operation.

- **LOW OIL LEVEL (Error Code 03)** - Alarm sounds, *lower display* reads “**Er03**” & *upper display* reads “**ERROR ALARM - CHECK OIL LEVEL - ENSURE VAT IS FULL**”. Fryer heating is disabled until condition is corrected. A temperature differential between a sensor at the **[ADD]** level & one placed against the heat exchanger exceeds an acceptable value, indicating low oil level. ***Operating with low oil levels greatly increases potential for fire!*** Press **[ALARM]** key to silence alarm & place **SELECTOR** switch in **[OFF]** position. Allow adequate cooling to ensure error reset; add oil to raise level to **[FULL]** mark ... **DO NOT overfill**.

- **LOW OIL LEVEL Post-error Warning (Error Code 06)** - When **Error 03** is cleared, a warning alarm occurs. *Lower display* reads “**Er06**” & *upper display* reads “**CHECK OIL LEVEL - ENSURE VAT IS FULL - PRESS [START]**”. This notification alerts operator to confirm that cooking oil is at the **[FULL]** level. If level is proper, press **[START]**. If oil is still needed, press **[ALARM]** key to silence tone ... add necessary oil, then press **[START]** key to return to operation.

- **MAX. ELEMENT TEMP (Error Code 19)** - The *heat exchanger* surface has exceeded the maximum allowed temperature. Alarm sounds, *lower display* reads “**Er19**” & *upper display* shows “**ERROR ALARM - MAX ELEMENT TEMPERATURE**”. Fryer heating is turned **OFF** & disabled ... fryer must cool to the acceptable temperature to clear the error. Typical cause of this error is low oil level, which has exposed some of the *heat exchanger* surface. False alarms can occur when preheating **cold** oil, like during initial startup of the day. Vigorously stirring oil during preheat will usually prevent, or clear, these false alarms.

- **MAX ELEMENT TEMP Post-error Warning (Error Code 07)** - After **Error 19** is cleared, a warning alarm occurs. The *lower display* shows “**Er07**” & the *upper display* reads “**MAX ELEMENT TEMP - PRESS [START]**”. This alarm alerts operator that a maximum element temperature error occurred & now has been cleared. Press **[START]** key to return to operation. Heating will not begin until **[START]** key is pressed.

NOTE: If an error condition cannot be resolved, please contact a factory-authorized service agent, or call 800.554.4537 for Giles Technical Support.

4.2 Cooking Procedures

Prior to starting the fryer for cooking operations do the following:

- Be sure that installation is complete & the fryer has been properly prepared & cleaned as described in **Section 2**.
- Fryer **Gas Valve Handle**, located on the right rear of the cabinet, is in the **ON** position (parallel to cabinet back).
- Be sure that proper ventilation is provided in the operating space.
- Be certain that gas supply line valve is **OPEN**, power cord is plugged into an appropriate outlet & main power to outlet is **ON**.



4.2 Cooking Procedures - continued

The following procedures assume you are starting with a clean empty fryer, which has been properly prepared for use ... basket lift in the **UP** position. These procedures may vary slightly depending on your actual standard practices or during continuous operation.

1. If necessary, remove basket from lift & set aside.
2. Place the **POWER** ① & **SELECTOR** ② switches in the **[OFF]** position.
3. Be sure the *drain valve* ③ is in the full **[CLOSE]** position (handle down to a stop).

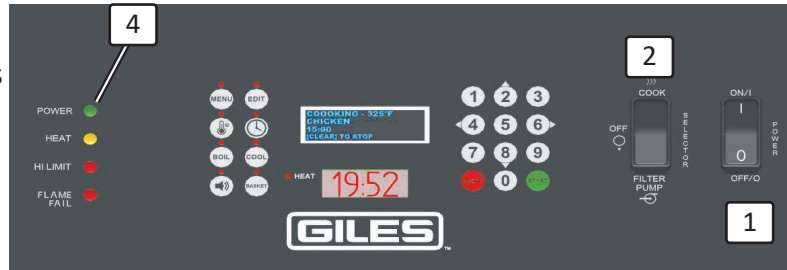

4. Place the **POWER** switch ② in the **[ON]** position. The **POWER** light ④ will turn **ON** & controller proceeds through the power-up sequence described in [Section 4.1.9, Start-Up Procedure](#).

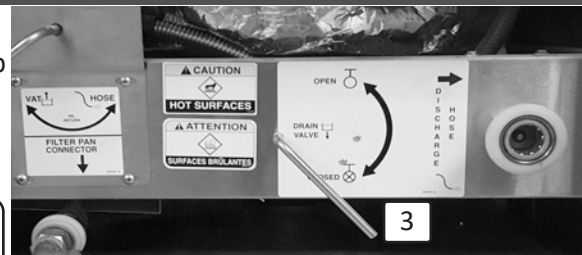

NOTE: If alarm sounds during power up & the message **ERROR ALARM DRAIN IS OPEN** is displayed, verify that the drain valve is tightly closed ... press the **[ALARM]** key & follow controller prompts.

5. Fill pot with your preferred liquid frying shortening ... fill only to the **[ADD]** mark at this time. Heated oil will expand & should bring level to near the **[FULL]** mark.

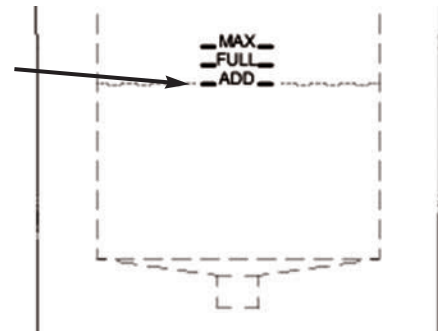

CAUTION DO NOT OVERFILL ... this could result in overflow, excessive splatter & potentially cause personal injury and/or damage to equipment.

NOTE: The Controller retains cook settings from previous cook cycle. If you wish to continue using these settings, skip step #6

6. Set Controller for cooking:

Use keypad ⑤ to manually set temperature & cook time, see [Section 4.1.3, Manually Setting a Temperature & Cook Time ...](#) OR ... select a desired Menu Item preset, see [Section 4.1.4.2, Selecting a Menu Preset for Cooking](#).

Once set, controller enters **PREHEAT** mode ... current cook settings are shown on the *upper display screen* & the real-time oil temperature is shown on *lower display screen*.

7. Place the **SELECTOR** switch ② in **[COOK]** position ... the **HEAT** light ⑥ will turn **ON**, the draft blower starts running & burner(s) will momentarily ignite to begin heating oil to temperature.

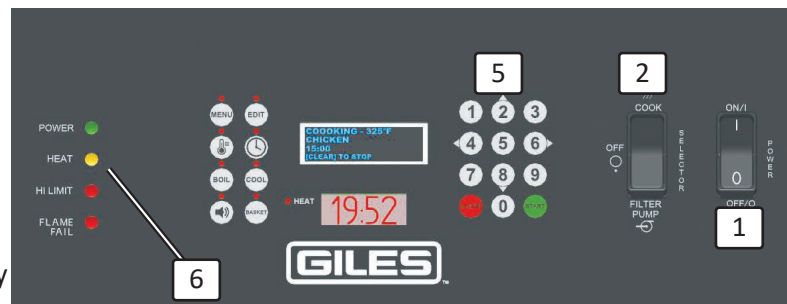

4.2 Cooking Procedure - continued

8. **NOTE:** If flame is not detected at the burner within a few seconds, the ignitor will shutdown, gas control valve closes & the red **FLAME FAIL** light ⑦ turns **ON**.

Return the **SELECTOR** switch ② to **OFF**. Wait 2 -3 minutes to allow gas to dissipate, then return switch to **[COOK]** to retry ignition.

If there are repeated ignition failures, see [Section 6, Troubleshooting ... Service call may be required.](#)

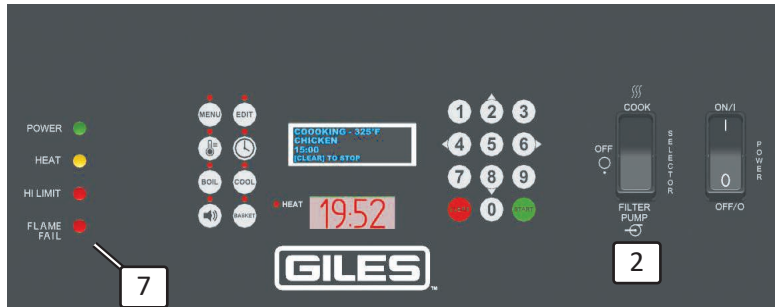

CAUTION Cooking oil is extremely **HOT!** Always wear thermal protection (gloves or oven mitts) when stirring hot oil.

9. As cooking oil heats, use the provided *stirring tool* to frequently stir the oil up from the bottom of pot. Doing so will help prevent formation of cool zones, promote more even heating through total volume of oil & also prevent occurrences of false **HI-LIMIT** alarms while heating.

10. When oil initially reaches setpoint temperature, burner(s) shutdown & **HEAT** light ⑧ will turn **OFF**.

11. An alarm sounds & message **"ALARM-STIR OIL"** is displayed on the *upper display screen*.



Press the **[ALARM]** key & vigorously stir again oil ... controller delays 10 seconds & during this time, if temperature drops a certain amount below setpoint while stirring, fryer returns to **PREHEAT** mode. A second alarm sounds when setpoint is reached again & message **"ALARM - SETPOINT REACHED"** is displayed. Press **[ALARM]** key to place fryer into **READY** state. *Lower display* changes to now show the setpoint temperature.

Oil should now be ready for cooking ...

12. Check oil level ... it should now be at, or near, the **[FULL]** level mark. If not, add oil & stir. Should the **HEAT** light turn **ON** after adding oil, continue stirring & wait until it turns **OFF** again before cooking.

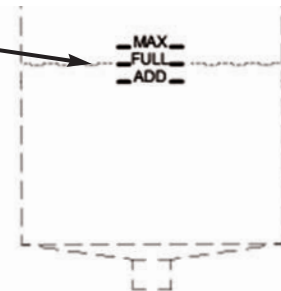

13. Place the Cooking Basket securely onto the basket lift carrier arm.

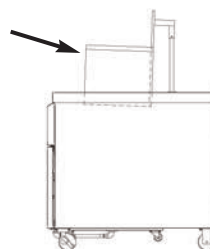

4.2 Cooking Procedure - continued

14. The settings set up in **Step-7** are shown on the *upper display* ⑨ along with a message “[START] TO COOK”. The **READY** notification indicates fryer is ready for cooking. If you wish, at this point, you can choose a different *menu preset -or-* enter different manual settings by following the steps in [Section 4.1.4.1](#) or [Section 4.1.3](#), respectively.

DO NOT exceed recommended full loads for bone-in, 8-way cut chicken as follows:

GGF-400: 14 lbs.

GGF-720: 24 lbs.

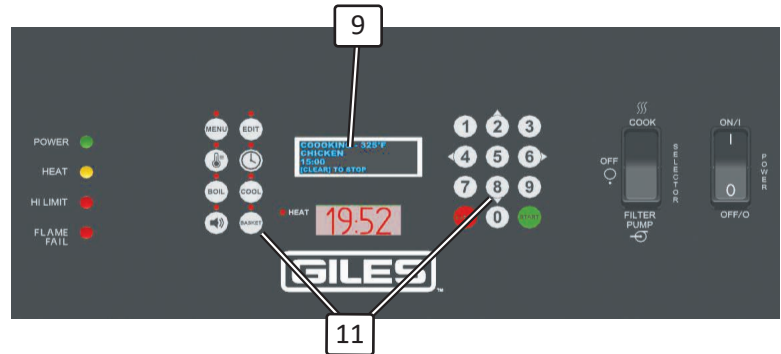

CAUTION If basket is lowered into pot before loading product, use extreme caution when placing product into HOT oil ... skin contact, or oil splash, can cause severe burn injury.

15. Uncooked product can be placed into cook basket ⑩ either before or after it has been lowered into the pot.
- To manually lower basket before loading product, press the [BASKET] key ⑪, then press [8] on keypad to lower. **NOTE: Basket lift will not operate unless controller indicates READY.**

- Load product into basket while in **UP** position. Basket will automatically lower when cooking cycle is started. Gently handle product to avoid letting loose crumbs & breading to fall from product into oil before it is lowered for cooking.

Controller must be in the READY state before a cooking cycle will start.

Press the [START] key. If **UP**, the basket lowers & cooking time will begin to countdown on the *lower display* screen.

Place the *Basket Cover* ⑫ over the fry kettle.

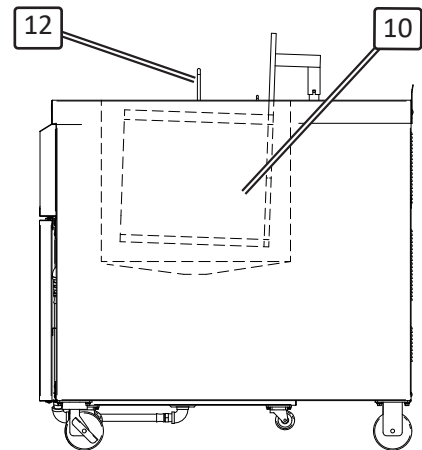

16. The controller display screens show current cook settings (*upper*) & time remaining in the running cooking cycle (*lower*).



4.2 Cooking Procedure - continued

NOTE:

Step #17 applies only if the [STIR ALARM ENABLE] setting is ON & the [STIR OVERRIDE] setting is NORMAL for item being cooked.

--- OR ---

[STIR ALARM ENABLE] is OFF & [STIR OVERRIDE] is FORCE.

If these are not the active settings, alarm will not sound.

Regardless of the settings used, it is recommended that the cooking product be gently stirred at some point during the latter half of the cook cycle to help promote even cooking & prevent pieces from sticking together.

17. When used, **STIR ALARM** sounds after a preset amount of programmed cook time has elapsed. The upper display reads “**ALARM - STIR**” Press the **[ALARM]** key to silence. **Wear thermal hand protection ...** remove the *basket cover* (12) ... *gently stir* & agitate the cooking product with the provided *stirring tool* (13) to separate pieces ... replace basket cover.

18. At the end of the cooking cycle, the basket (14) of cooked product will be automatically raised from the fry kettle. An alarm sounds & message “**DONE COOKING**” is shown on the upper display. Press the **[ALARM]** key to silence alarm.
The fryer returns to **READY** state awaiting the next load.

19. Public health regulations & food service guidelines generally mandate that internal temperature of cooked protein products indicate a prescribed level of doneness before being sold for consumption. In accordance with your specific operating procedures, check the internal temperature of the cooked product. Check some of the larger pieces with a digital probe-style food thermometer. If food temp is lower than required, additional cooking time is needed.

The fryer controller has a feature that allows operator to easily provide minutes of additional cooking time by pressing the **[0] key + minutes to add**. This can be done either after the cook cycle is complete, or while it is still active. *It is best that added cooking time be done in 1-min increments to avoid over-cooking.*

To use this feature, the user setting “**[0] KEY EXTRA TIME**” must be set **ON**. See [Section 4.1.7, User Settings](#).

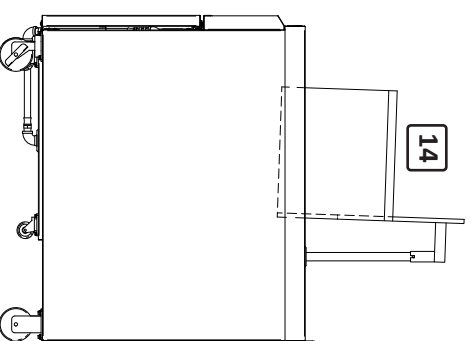
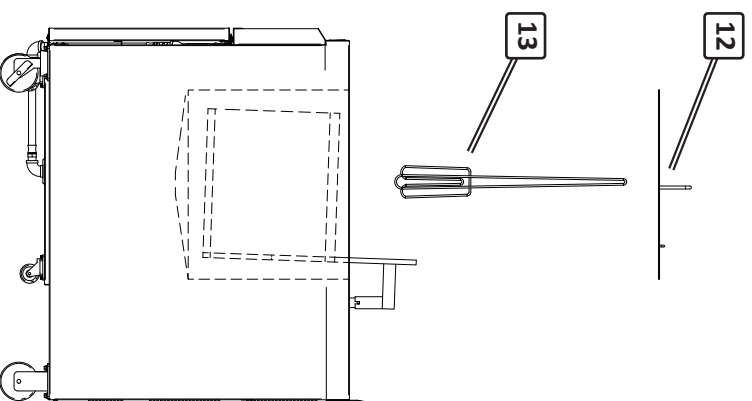

4.2 Cooking Procedure - continued

20. After properly confirming doneness, allow oil to drain adequately. **Wear oven mitts, or other thermal protection ...** remove the pot cover & hang it onto the basket carrier arm. Carefully lift basket off of the carrier arm & dump cooked product into an appropriate dump station or food service pan.
21. a.) To cook another load ... return to **Step #12** of this procedure.
b.) To place fryer in standby **COOL Mode** ... see Section 4.1.6.2, Cool Mode.
c.) To shutdown fryer ... see Section 4.5, Normal Shutdown.

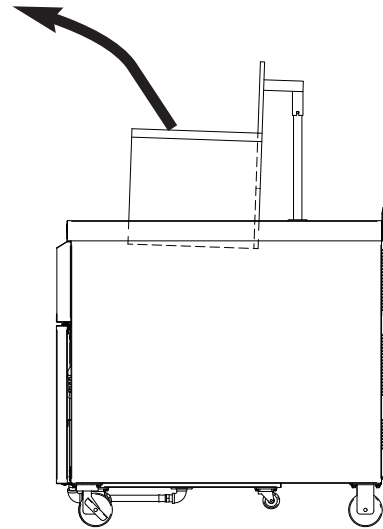

IMPORTANT!

*In an attempt to promote product drainage or to dislodge cooking residue from basket, **DO NOT** forcefully strike it (full or empty) against the edge of the fryer cabinet, rim of the pot, basket carrier arm or any other hard surface. Doing so can damage the basket and/or appliance ... such damages are not covered by the factory warranty.*

4.3 Filtering Used Cooking Oil

This section explains use of the on-board *Oil Filtration System* for filtering & reconditioning used cooking oil. The system draws oil through a filter media in the *Filter Pan* bottom & circulates it back to the fry kettle. Routinely performing this procedure can help maintain good food quality, as well as, increase the useful life of the oil by as much as 50%.

The **GGF** fryer is equipped with a **FORCE FILTER** feature, which can be set to force operating personnel to filter oil according to specific management preferences. The feature is configured in *User Settings*, see **Section 4.1.7**.

- **FORCE FILTER** - [ON] or [OFF] • **Factory-set default: ON.**
[ON]: After completing a set number of cook cycles (defined by **FILTER COUNT**), alarm sounds & message **“ALARM - MUST FILTER OIL”** is displayed on *upper display screen*. Pressing the **[ALARM]** key silences alarm & fryer enters **FILTER MODE**. The appliance is *locked out* from further operation until the filter process is properly completed.
[OFF]: After completing a set number of cook cycles (defined by **FILTER COUNT**), alarm sounds & message **“ALARM - FILTER OIL”** is displayed on *upper display screen*. Pressing the **[ALARM]** key silences alarm & fryer returns to **READY** state ... *the appliance is not locked out*. You can continue to cook, however this alarm sounds & notification is displayed after every subsequent cook cycle until filtering is completed.
- **FILTER COUNT** - 1 to 20 • **Factory-set default: 4.**
 The number of cook cycles that can be performed before fryer enters **FILTER MODE**.
- **FORCE FILTER SNOOZE** - [ON] or [OFF] • **Factory-set default: OFF.**
 Effective only when **FORCE FILTER** is [ON].
[ON]: Allows operator to cook **one (1) additional load of product** after **FILTER COUNT** has been reached, before fryer enters **FILTER MODE** & is locked-out.
[OFF]: No additional cook cycle allowed.

In addition to general **FORCE FILTER**, each *Menu Item Preset* has an available **FISH FILTER** setting ... when set to **ON**, it overrides the controller setting & puts fryer into **FILTER MODE** after cooking **only (1) batch** of the particular menu item. This feature is typically used for seafoods in an attempt to minimize possibility of flavor transfer to other foods which may be cooked in the same fryer. See **Section 4.1.4.1, Editing a Menu Item Preset** for more detail.

CAUTION **DO NOT** attempt to filter cold cooking oil. The filter pump can clog & be damaged. Oil should be at a minimum of 200°F (93°C) before pumping.

1. After cooking the preset number of loads defined by **[FILTER COUNT]** the alarm sounds.
2. If **FORCE FILTER** is **OFF**, display ① reads **“ALARM - FILTER OIL”**, press **[ALARM]** key ② to silence. **Until the oil is filtered, this alarm notification will occur after every subsequent load cooked as continuing reminder that the oil has been used past a prescribed no. of loads & needs filtering.**

If **FORCE FILTER** is **ON**, display ① reads **“ALARM - MUST FILTER OIL”**, press **[ALARM]** key ②.

Fryer enters **FILTER MODE** & is **locked-out of continued operation** until the oil is properly filtered.

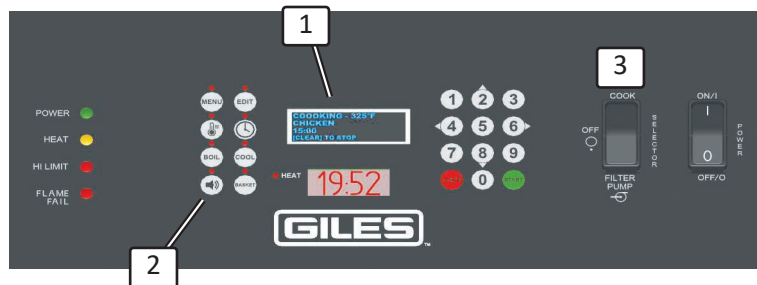

3. Place **SELECTOR** switch ③ in **[OFF]** position. **IMPORTANT! The POWER switch must remain ON during the entire filtering process.**

4.3 Filtering Used Cooking Oil - continued

CAUTION Always wear thermal protection (gloves or oven mitts) while performing the filtering process. Fryer parts inside the cabinet can be extremely HOT!

- Open cabinet & disconnect the filter pan hose ④ (push in white slip-ring & pull hose from coupling) ... remove filter pan ⑤ from cabinet.
- Remove filter pan cover ⑥ to verify that filter media (generally, 1 sheet of filter paper) is in place & that any remaining filtering residue has been cleaned from the media surface. Ensure that hold-down frame is locked properly in place.
- Evenly distribute approximately **5 ozs** of a suitable filter aid powder product over the filter media surface. Use of a good quality filter aid powder is essential for removing soluble impurities & reconditioning oil. **Portion packed Filter Powder is available from Giles dealers & distributors ... P/N 72004.**

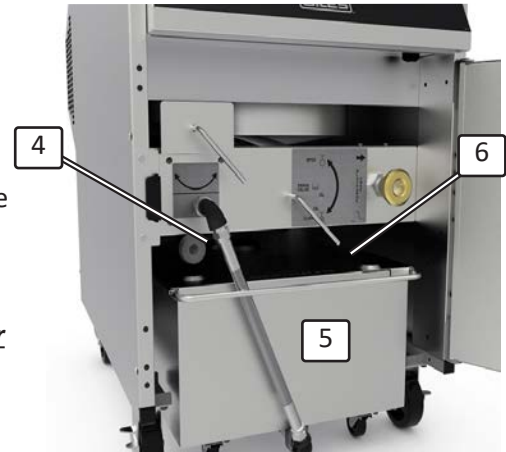

- Replace pan cover & reposition the assembled filter pan inside cabinet ... reconnect the filter pan hose ④ (push in on white slip-ring while inserting brass fitting into coupling). **Ensure that the hose fits tight & secure.**

DANGER The next steps require that cooking oil be drained into the filter pan, exposing the heat exchanger. Fryer is equipped with safety interlocks which disable fryer heating anytime the drain valve is opened, however as further safeguard to reduce risk of oil fire, always place **SELECTOR switch OFF** prior to draining. **NEVER USE THE DRAIN VALVE AS AN "ON/OFF SWITCH".**

- Ensure control panel **SELECTOR** switch is in **OFF** ... **POWER** switch must remain **ON**. Place the oil diverter valve ⑦ in the **VAT** position. Slowly turn the drain valve handle ⑧ to the **OPEN** position. Allow used oil to drain into filter pan ⑤.

NOTE:

To help contain oil splash & splatter, be sure filter pan cover remains in place while draining pot.

If pot does not readily drain, use the provided Kettle Drain Brush (P/N 72025) to break up crumbs or debris that might be blocking the drain opening. **Be careful not to push brush so far down as to puncture filter media in the filter pan. Doing so could allow excessive debris to enter the filter pump, potentially clogging it & causing damage.**

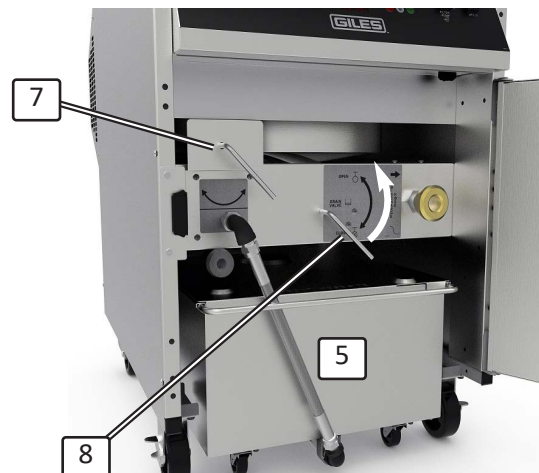

4.3 Filtering Used Cooking Oil - continued

9. When majority of oil has drained from pot into the *filter pan*, place the **SELECTOR** switch ⑨ in the **[FILTER PUMP]** position.
10. The pump starts ... oil is drawn through the filter media & filter aid, then pumped back into the pot. *Leave the drain valve open & allow oil to continually circulate to act as a “crumb wash” & flush residue into the filter pan.*



During this time use the provided heat-resistant brushes to scrub residue from pot & heat exchanger surfaces. Use straight kettle drain brush to clean between pot wall ⑩ & heat exchanger wall ⑪. On the GGF-720 model only, clean between the top and bottom heat exchanger tubes ⑫ using the clean out tool provided when cleaning between the pot wall & heat exchanger wall. Allow recirculating oil to flush the pot.

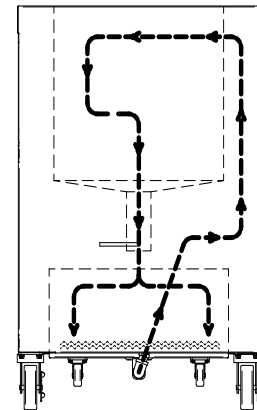

⚠ WARNING

Failure to properly clean the heat exchanger, as described herein, can result in excessive carbon build-up between the pot wall, heat exchanger wall, and heat exchanger tubes. These carbon deposits can lead to premature failure of the pot, heat exchanger, and heat exchanger tubes and will void the factory warranty.

EXTREMELY IMPORTANT!!

- Each time fryer oil is filtered, it is important that the front & back of the GGF-400 & GGF-720 heat exchanger be cleaned thoroughly. Use the *Heat-resistant Utility Pot Brush* (P/N 71100) to scrub the front surface & top edge.
- Use the *Heat-resistant Straight Kettle Drain Brush* (P/N 71025) to clean the surfaces on either side of the space between the pot wall ⑩ & the outside of the heat exchanger wall ⑪ of the GGF-400 & GGF-720.
- Move *straight kettle drain brush* up/down & side to side, around the entire pot & pot wall, pushing the brush down until it touches the pot bottom ... ensure that the entire depth of the wall is cleaned. depth of the wall is cleaned.

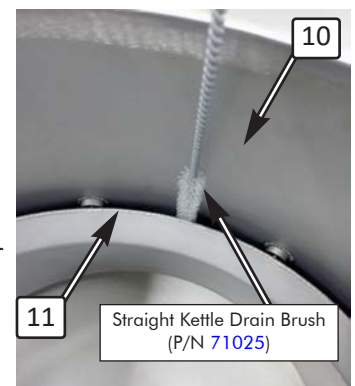

*Extremely Important Information
Continued on Next Page*

4.3 Filtering Used Cooking Oil - continued

⚠ WARNING Failure to properly clean the heat exchanger, as described herein, can result in excessive carbon build-up between the pot wall, heat exchanger wall, and heat exchanger tubes. These carbon deposits can lead to premature failure of the pot, heat exchanger, and heat exchanger tubes and will void the factory warranty.

EXTREMELY IMPORTANT!! (continued)

- On the **GGF-720 model only** it is necessary to thoroughly clean the area between the top and bottom heat exchanger tubes (12) using the provided *Clean-Out Tool* (P/N 80434).
- On the **GGF-720 model only** place the *clean-out tool* between the pot wall (10) & heat exchanger wall (11). Move the *clean-out tool* between the top and bottom heat exchanger tubes (12). Move the *clean-out tool* up & down, to dislodge any accumulated crumbs or cooking debris and clean the pot wall.

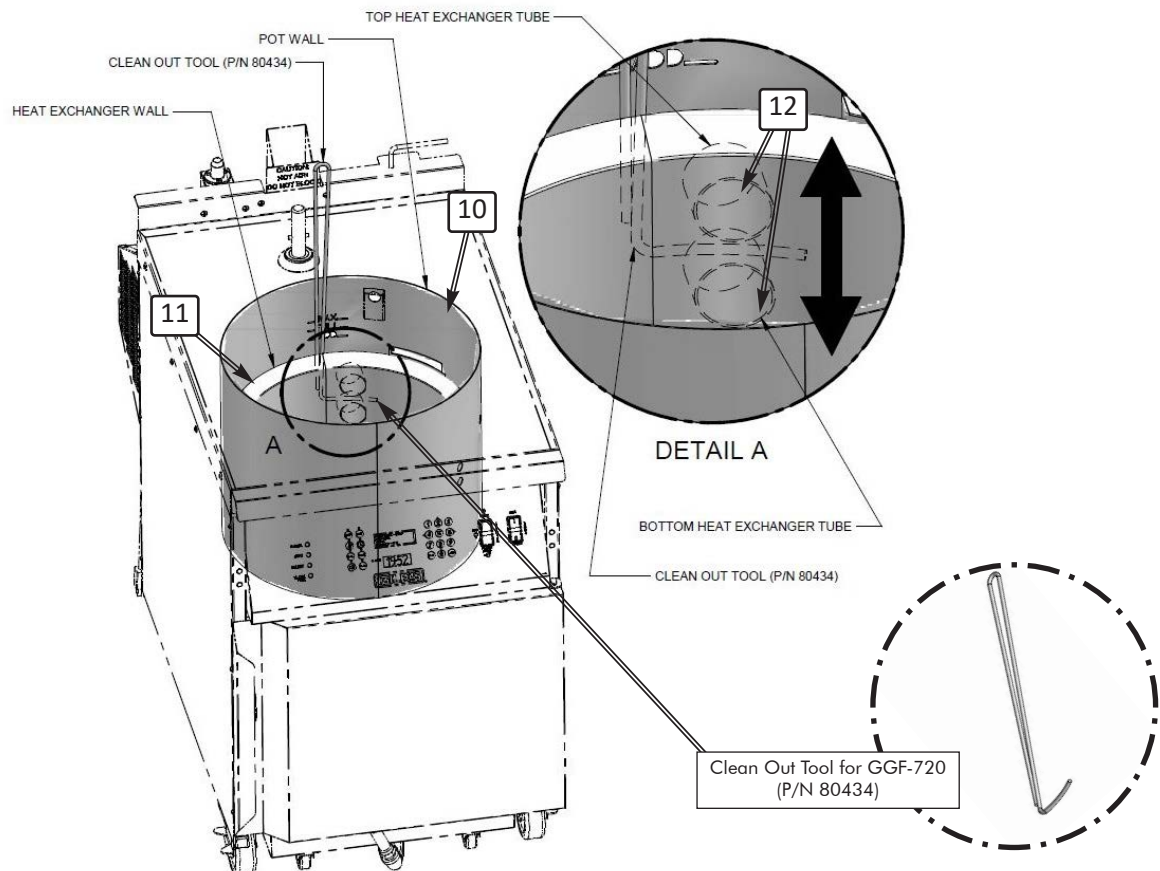

- **The areas adjacent to the heat exchanger entrance duct require special cleaning attention.** If crumbs & cooking debris accumulate in these areas, hard carbon deposits will form over time. If not removed, these deposits will cause excessive heat build-up & result in permanent damage to metal & welded joints, leading to a fatal failure of the heat exchanger, heat exchanger tubes, & pot.
- **Such damages may not be covered by factory warranty.**

4.3 Filtering Used Cooking Oil - continued

11. After approx. **5 mins**, or until oil appears to run clear, return the drain valve handle (8) to the **CLOSE** position ... allow pot to refill with the filtered / reconditioned oil.
12. When all oil has been pumped back into the pot, place the **SELECTOR** switch (9) in **OFF** position (centered) to stop pump.
13. Be sure oil level is at the **[FULL]** mark, add fresh oil if needed.
14. **Wear thermal hand protection**, disconnect filter pan hose (13) ... remove the filter pan from cabinet & lift off pan cover.
15. Using the provided crumb scoop (p/n 30059) (14), remove filter sediment from the surface of the filter media & discard. *Unless there are obvious holes or tearing, it is not essential to replace the filter media after every filtering cycle.*

IMPORTANT! At a minimum, filter pan should be thoroughly cleaned & media refreshed **DAILY**, see Section 5.2, Cleaning Filter Pan & Replacing Filter Media.

16. Replace cover, reinstall filter pan into cabinet & connect properly.
17. To continue cooking, See Section 4.2, Cooking Procedure. To discontinue cooking, See Section 4.5, Normal Shutdown.

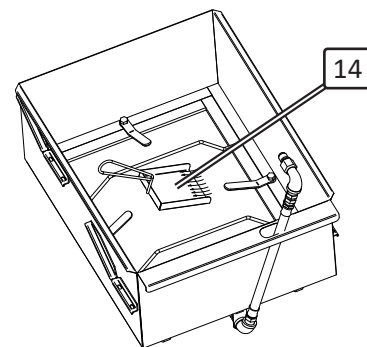
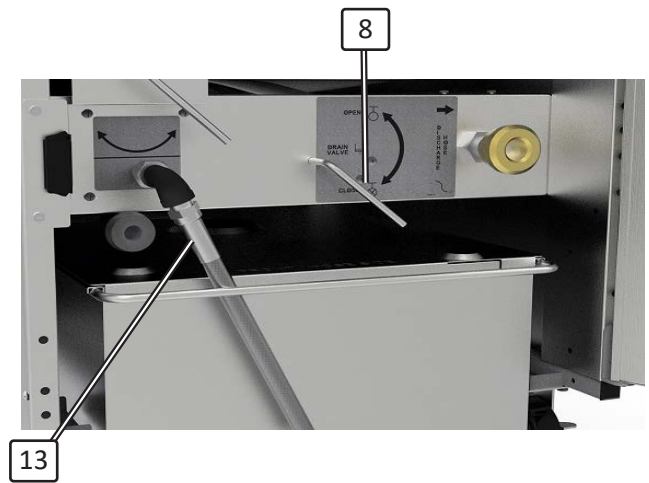

IMPORTANT!

When **FORCE FILTER** is **ON**, the fryer will not exit **FILTER MODE** & return to normal operation unless the controller detects ... 1). opening of the drain valve & ... 2). actual oil temperature lower than the **[FILTER RESET]** temperature parameter specified in *user settings*. Generally, oil cools sufficiently when filtered to reset the controller ... *factory-set default is 290°F*.

For the controller to reset properly from **FILTER MODE**, the **POWER** switch must remain **ON** throughout the entire filter process. If switch is turned **[OFF]**, controller will not detect drain opening or oil temperature & will not reset.

4.4 Removing Waste Oil from Fryer

This section explains the procedure for removing & disposing of waste cooking oil. To maintain the quality of cooked foods, oil should generally be changed every **7 to 10 days**, depending on your filtering practices, types of foods & the quantities cooked regularly. Oil must also be removed before a *Boil-Out procedure* is performed to clean the fry kettle.

In this section a **Giles Oil Caddy (not provided)** is referenced as waste oil handling equipment.

CAUTION DO NOT attempt to pump cold, congealed oil. The filter pump can clog & be damaged. Oil should be at a minimum of 200°F (93°C) before pumping.

1. If needed, preheat oil to **200°F (93°C)**.
2. Be sure the **POWER ①** & **SELECTOR ②** switches are both in the **[OFF]** position.
3. Open cabinet & ensure filter pan ③, with filter media is in place & the filter pan hose ④ is properly connected to fryer.
4. Slowly turn the drain valve handle ⑤ to the **OPEN** position (up to a stop) & allow all oil to completely drain from pot.



NOTE: If pot does not readily drain, or drains very slowly, use the supplied *Kettle Drain Brush* (P/N 71025) to break up crumbs & clear them from in the drain. **Be careful to not push brush down far enough to possibly puncture the filter media in the filter pan ... a hole could allow debris to enter & clog the pump.**

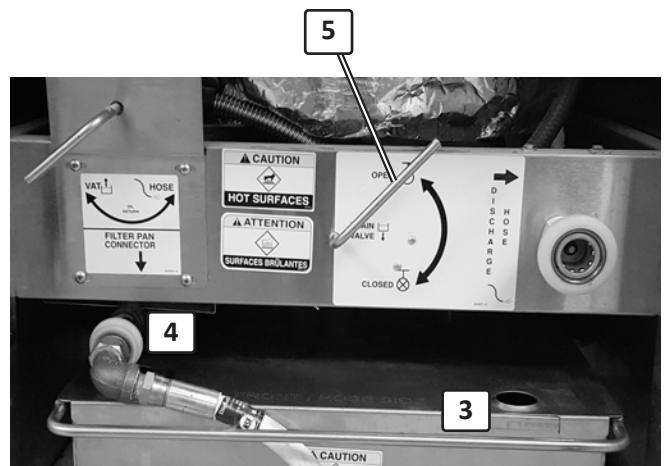

4.4 Removing Waste Oil from Fryer - continued

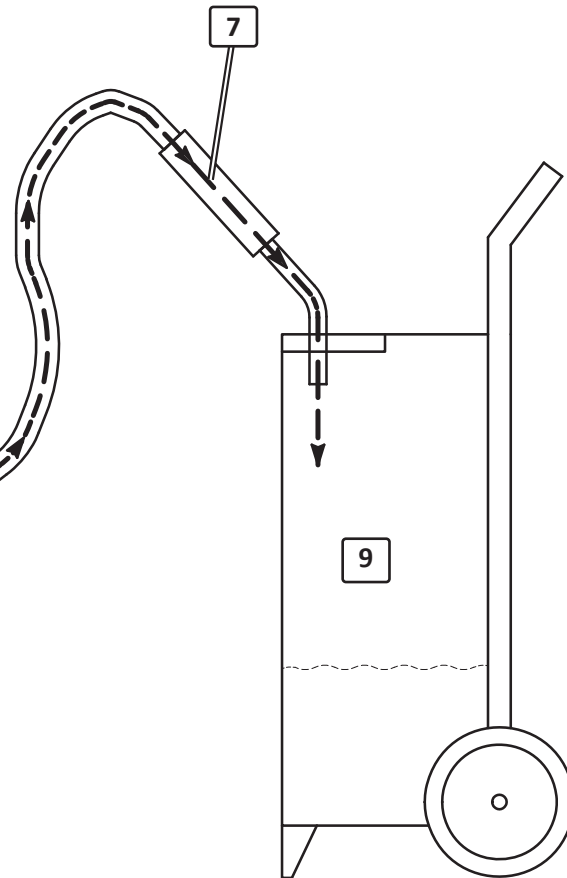
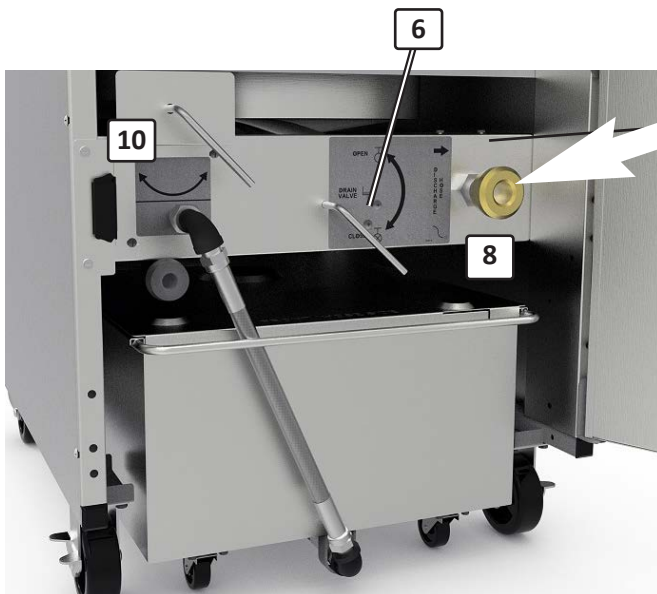

5. After the pot has completely drained, turn the drain valve handle (6) to the **CLOSE** position (down to a stop).
6. Connect the provided Oil Discharge Hose (7) to the quick-coupling (8).
7. Place the discharge wand into a suitable heat-resistant waste oil disposal container (9) (*Giles Oil Caddy is depicted, not included*).
8. Place the oil diverter valve (10) in the [**HOSE**] position (right to stop).
9. ***Wear thermal protective gear to hold the discharge hose ... parts of it can become very hot while pumping oil.*** Set the **SELECTOR** switch (11) to the [**FILTER PUMP**] position. Waste oil is pumped into the disposal container.
IMPORTANT! Always attend this process to avoid the possibility of accidental hot oil spillage.

4.4 Removing Waste Oil from Fryer - continued

10. After all waste oil has been pumped from the filter pan, return **SELECTOR** switch to **OFF**.
11. Place **POWER** switch to **OFF**.
12. Return the *oil diverter valve handle* (10) to the **[VAT]** position (left to stop).
13. **Wearing thermal protective gear**, remove the discharge hose from the quick-coupler & drain any oil remaining in the hose into the waste oil container.
14. Thoroughly clean the filter pan as described in **Section 5.2, Cleaning Filter Pan & Replacing Filter Media.**
15. After removal of waste oil, a *Boil-Out procedure* should be performed promptly. See **Section 5.1, Boil-Out Procedure.** ***DO NOT*** allow oil residue to remain in the pot for an extended period of time without *boiling out or refilling with fresh oil ...* over time residue will become more difficult to remove & eventually can lead to an undesirable build-up that can negatively impact fryer performance & food quality.
 - ◇ If *boil-out* must be postponed, as a minimum, while oil is still warm use absorbent paper wipes to clean as much residue as possible from pot surfaces & heat exchanger, then refill pot with fresh oil. Restart fryer as described in **Section 4.2, Cooking Procedures** & continue operation.
16. To perform the *boil out*, see **Section 5.1, Boil-Out Procedure.**
To shut down the unit, see **Section 4.5, Normal Shut-Down.**



4.5 Normal Fryer Shutdown

1. Place the **SELECTOR** switch ① in the center **OFF** position.
2. Place the **POWER** switch ② to **OFF** ... **POWER** light ③ turns **OFF**.
3. Place the *gas valve handle* ④ in the **OFF** position, *handle pointing toward front of fryer*.
4. If required to disconnect all supply power from the appliance, unplug power cord from receptacle or turn **OFF** circuit breaker in the electrical panel supplying power to unit.
5. If required, turn off main gas supply line valve.



4.6 Emergency Fryer Shutdown

In case of emergency, remove power to the unit by turning off the facility circuit breaker and shut off main gas supply line.

5. Cleaning

This section describes procedures for cleaning & maintaining *GGF Series Gas Fryers*, which are necessary to keep them in good operating condition. **General cleaning of the appliance should be performed daily** & other activities should be preformed as described by the following.

⚠ DANGER **DO NOT** wash down the interior or exterior of fryer with water from a spray hose, or any pressure-type washer.

Failure to comply with DANGER notices will result in death or serious injury, equipment or property damage, and void the warranty.

5.1 Boil Out Procedure (Cleaning the Fryer Pot)

The following explains a **Boil-Out Procedure** for cleaning & degreasing the fryer pot & heat exchanger. This procedure should be performed promptly after disposing of used waste oil, before refilling fryer with fresh oil. It should also be part of preparing a new fryer for use.

For proper maintenance & to ensure satisfactory operation and food quality, the procedure should be performed every 7 to 10 days, however, exact timing of oil replacement is highly dependent on many factors. Oil testing kits, which can help accurately determine oil condition & when replacement is needed, are available from most restaurant supply companies.

⚠ CAUTION

- The **Boil-Out** process does not require a rolling boil ... nevertheless, **DO NOT** leave fryer unattended during the procedure. It should be carefully monitored to avoid accidental overflows, which could result in serious equipment damage.
- Fryer & boil-out solution will become very HOT ... always wear thermal hand protection, as well as, other personal protective equipment (*face-shield, latex apron, etc.*) when performing the procedure.
- Closely follow the manufacturer's usage instructions for *fryer degreaser-cleaner* products. These products may contain chemicals, which require special precautions. If used improperly, equipment damage and/or personal injury could result.



1. Remove waste cooking oil from the fryer as described in **Section 4.4, Removing Waste Cooking Oil**.
2. Confirm that the **Drain Valve Handle** ① is in the fully **CLOSE** position.
3. Ensure **SELECTOR** switch is in the **OFF** position.
4. Use absorbent wipes to clean as much waste oil residue as possible from pot & heat exchanger. Begin filling pot with clean ambient water.
5. Use a reputable **fryer cleaning** product & carefully follow the manufacturer's usage directions. Add the recommended amount to pot while filling, stir to mix & continue filling to the [**FULL**] level mark ②.

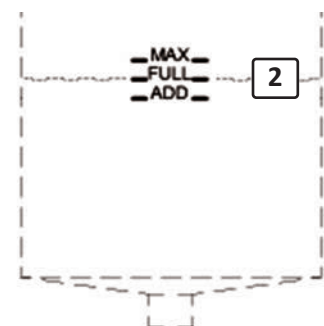

Giles Fryer Boil Out cleaner is available through *Giles equipment dealers & distributors* ... **part number 72003, case of (24) 6-oz premeasured packets.**

5.1 Boil Out Procedure - continued

5. Place **POWER** switch ③ in **ON** position.
6. Place the **SELECTOR** switch ④ in **COOK** position.
7. After controller powers-up & alarm sounds, press **[START]** key to enter **PREHEAT** ... amber control panel **HEAT** light turns **ON** & solution begins heating. *Upper display reads "PRESS [BOIL] - GO TO BOIL-OUT"*. Press the **[BOIL]** key ⑤ to place fryer into **BOIL OUT mode**. Temp setting changes to **200°F (93°C)** & time begins countdown from **30 mins**. Allow the boil out cycle to run completely. *These values can be changed in user settings, Section 4.1.7*
8. When boil out cycle time expires, the **"DONE COOKING"** alarm sounds ... place both **SELECTOR** ④ & **POWER** ③ switches in **OFF** position.
9. Disconnect & remove *Filter Pan* from fryer.



NOTE:

As a safeguard, when a boil out cycle ends, the controller temperature setpoint automatically changes to **50°F**. Before cooking activities can resume, a *menu item preset* must be re-selected or temperature setpoint must be re-entered manually.

IMPORTANT!!

DO NOT drain used boil-out solution into the filter pan or run through filter pump! It is corrosive & can cause damage to components. Equipment failures and/or malfunctions caused by such actions are not covered by the factory warranty

10. Position a suitable **heat resistant catch container** ⑥ (*not provided*) beneath the fryer drain.

CAUTION The container used for this step should be heat resistant up to **300°F (148°C)**. **Plastic is NOT acceptable**, as it may soften & break. A leak-proof metal container should be used. Failure to comply with this caution could result in personal injury.

If a suitable floor drain is available nearby, slowly draining solution onto floor & squeegeeing into the drain is an acceptable alternative, but *may require a helper*.

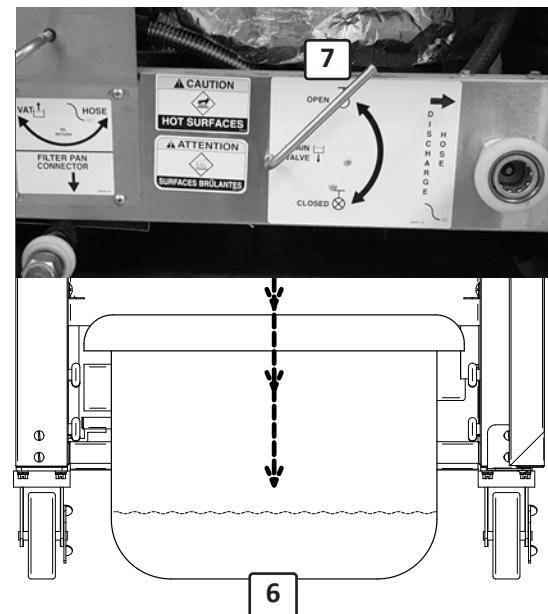

11. Slowly turn the **drain valve handle** ⑦ to the **OPEN** position ... allow used cleaner solution to drain from pot. If using catch container, carefully monitor & empty as needed. As solution drains, clean heat exchanger & pot surfaces, scrubbing with the provided brushes.

5.1 Boil Out Procedure - continued

⚠ WARNING Failure to routinely clean the areas of the heat exchanger, as described below, can result in excessive carbon build-up between the pot wall, heat exchanger wall, and heat exchanger tubes. These carbon deposits can lead to premature failure of the pot and combustion chamber, and will void the pot warranty.

EXTREMELY IMPORTANT!!

- **The area adjacent to the heat exchanger entrance requires special cleaning attention.** If hard carbon deposits are allowed to form in this area, excessive heat build-up can cause severe metal fatigue, resulting in permanent damage & a fatal failure of the heat exchanger, heat exchanger tubes, and pot. Such damage may not be covered by the factory warranty.
- During the boil-out procedure, use the Straight Kettle Drain Brush to scrub the area between the pot wall & heat exchanger wall on the GGF-400 & GGF-720.
- It is also necessary to clean between the top & bottom heat exchanger tubes on the GGF-720 using the Clean-Out Tool.

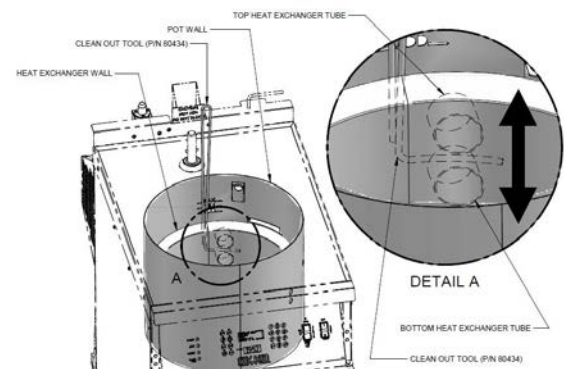
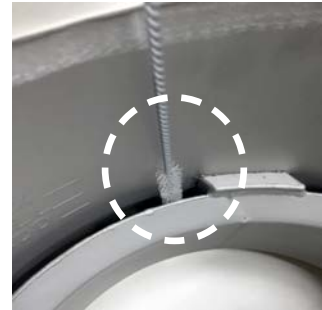

12. Rinse & flush pot thoroughly with clean hot water. **Empty catch container as often as needed or continue to squeegee to floor drain.**
13. Dry the pot with clean dry, sanitized, towels. Ensure surfaces are completely dry before adding fresh cooking oil.
14. Return **drain valve handle** (7) to the **CLOSE** position (fully down to stop).
15. Clean **filter pan** and refresh **filter media** as described in **Section 5.2, Cleaning Filter Pan Components.**
16. Replace **pan cover** (8) & reposition **filter pan** under fryer & connect the **filter pan hose** (9) at the fryer coupling.
17. Refill pot with fresh liquid frying shortening & restart fryer as described in **Section 4.2, Cooking Procedures.**

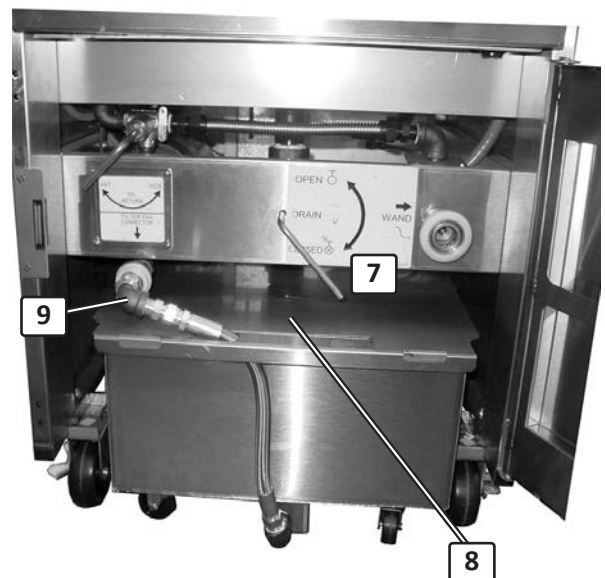

IMPORTANT! Be certain that the pot is completely rinsed & dried before adding fresh cooking oil. Give particular attention to the drain valve area, as residual water may pool in the space above the valve. Water contamination will cause boiling and foaming of hot cooking oil, which could result in overflow.

5.2 Cleaning the Filter Pan & Refreshing Filter Media

This section describes the procedure for cleaning the **filter pan** & replacing **filter media**. Perform this after each **Boil-Out Procedure**, as well as part of the **daily cleaning routine**.

GILES recommends using a non-toxic, non-detergent, biodegradable degreaser cleaner, such as SIMPLE GREEN® Crystal Foaming Spray Cleaner/Degreaser along with hot water, to clean the filter pan & components.

CAUTION Wear thermal hand protection as safeguard from hot parts.

1. Shutdown fryer using *normal shut-down*, see **Section 4.5**
2. Remove **filter pan** (1) from fryer & lift off **pan cover** (2). Clean & dry cover thoroughly.
3. If equipped, remove the **Crumb Catcher Screen** (3)* ... clean & dry thoroughly.
4. Using the provided metal **Crumb Scoop**, remove accumulated filter residue from the surface of the filter media, especially around the edge of the **hold-down frame** (4).
5. Turn **locking levers** (6) to disengage the **hold-down frame** from pan bottom. Remove frame, clean & dry thoroughly.
6. Grasp edge of **soiled sheet of filter paper** (5), carefully roll it up, avoid allowing filter debris to fall through **perforated screen** (8) in the pan bottom ... discard sheet.
7. Clean **filter pan**, rinse thoroughly & dry completely. Be certain to drain all water from filter pan piping & hoses.
8. Reassemble **filter pan** ... use one (1) fresh sheet of **filter paper (proper size 15-1/2" x 21-3/8")** ... lay flat on top of support screen. Place **hold-down frame** & close all locking levers, be sure frame is securely engaged.
9. Replace **pan cover** & place assembled **filter pan** under fryer & reconnect hose at quick-coupling.

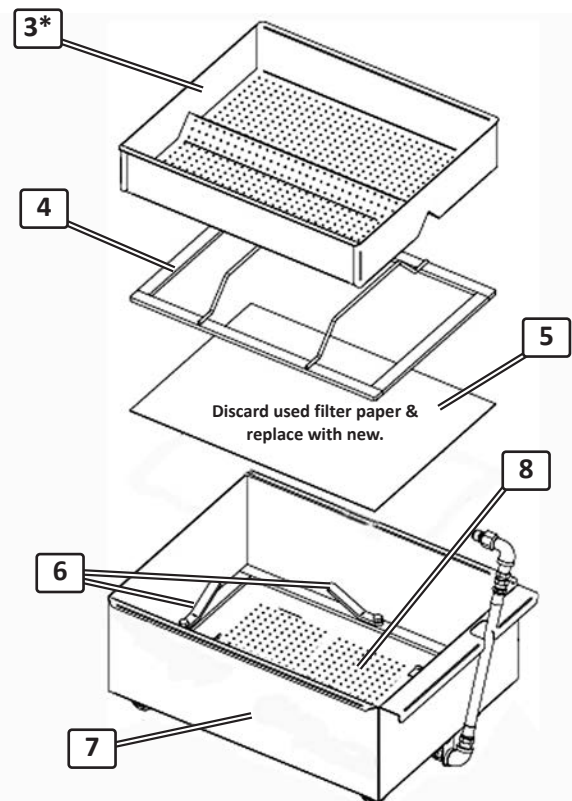
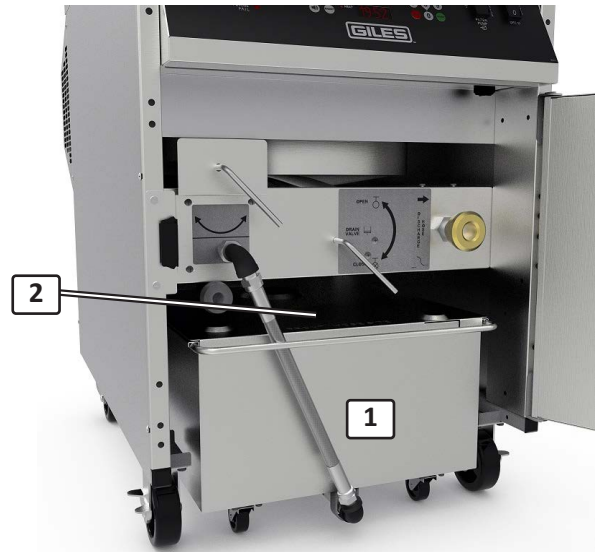

NOTE:

A stainless steel, woven-wire mesh **Filter Screen (P/N 41014)** is available as a direct substitute for paper filter media. It is cleanable & reuseable ... designed to reduce cost of operation & eliminate the waste stream of filter paper disposal. Using it along with a good filter aid powder, such as **Giles Filter Powder (P/N 72004)**, yields the same results as filter paper.

Purchased separately ...

* Accessory, not included, purchased separately

6. Troubleshooting

This section describes troubleshooting procedures for model *GGF Gas Fryers*. Refer to the wiring diagram provided with the unit, as needed. Generally, troubleshooting and repair must be performed by a qualified kitchen equipment service technician. Users should only attempt to correct issues dealing with operating procedures.

6.1 Temperature Control System

Problem	Probable Cause	Repair Procedure
FRYER WILL NOT TURN ON: No power light	A. Not connected to power source.	Verify power cord plugged into outlet.
	B. Blown fuse or tripped circuit breaker.	Check fuse or breaker.
	C. Damaged fuse holder.	Replace fuse holder.
	D. Faulty POWER switch.	Replace POWER switch.
	E. Improper supply voltage.	Connect to proper power supply.
FRYER WILL NOT HEAT: POWER light ON. HEAT light not ON ... no alarm sounding	A. SELECTOR switch not in COOK position.	Place SELECTOR switch in COOK position.
FRYER WILL NOT HEAT: POWER light is ON <i>Selector Switch</i> is in [COOK] position HEAT light is OFF	A. Temp setpoint is lower than actual oil temperature.	Check setting & oil temp; correct if needed, or if satisfactory begin cook cycle.
	B. "DRAIN OPEN" message; alarm sounding	Close valve fully to reset alarm
	C. Faulty cooking Controller.	Replace Controller.
	D. Temperature sensor faulty; Er13 displayed	Check wiring; replace sensor
	E. Faulty SELECTOR switch	Check/replace switch
	F. Vacuum switch out of adjustment.	Adjust vacuum switch.
	H. Faulty draft blower.	Replace blower.
	I. Power-up procedure not completed	Press [START] to begin PREHEAT

6.1 Temperature Control System - continued

Problem	Probable Cause	Repair Procedure
BURNER(S) WILL NOT IGNITE: POWER light ON . HEAT light ON FLAME FAIL light ON	A. Main gas supply line valve is CLOSED .	Open gas valve.
	B. Fryer gas valve is CLOSED .	Move gas valve handle to OPEN position.
	C. Flame Sensor faulty, dirty or mis-aligned.	Clean, adjust or replace Flame Sensor.
	D. Incorrect gas pressure.	Correct gas pressure.
	E. Orifice size incorrect.	Install proper orifice.
	F. Faulty Gas Control Valve.	Replace Gas Valve.
	G. Faulty Ignitor.	Replace Ignitor.
	H. Faulty Ignition Module.	Replace Ignition Module.
	I. Faulty Gas Valve Transformer.	Check & replace Transformer
	J. Dirty burner.	Clean burner
FRYER WILL NOT HEAT: POWER light ON . HEAT light not ON . Alarm sounding or Error Message displayed.	A. Drain Valve open.	Close valve completely.
	B. Loose wiring.	Check & repair wiring.
	C. Low oil level	Add oil to FULL level.
	D. Heat exchanger exceeded max temp	Allow unit to cool, error will automatically clear.
	E. Fryer is in <i>FILTER MODE</i>	Consult Operations Manual

6.1 Temperature Control System - continued

Problem	Probable Cause	Repair Procedure
FRYER WILL NOT HEAT: POWER light ON . HIGH LIMIT light ON HI-limit Safety Thermostat is tripped	A. Power surge has tripped hi-limit thermostat.	Cycle fryer power OFF for 5 seconds to reset.
	B. Plug loose in wall receptacle.	Check & insert plug firmly.
	C. Low oil level	Add oil to FULL level.
	D. Faulty High-Limit board	Replace board.
	F. Faulty or mis-positioned High-Limit probe.	Replace Probe; check & reposition if needed..
	G. Line noise or voltage spikes.	Install line filter.
	H. Faulty controller	Replace controller
	I. Faulty temp sensor	Replace probe
FRYER HEATS SLOW: Slow recovery HEAT light staying ON continuously .	A. Improper cooking procedure.	Consult Operations Manual for proper operating procedures.
	B. Burner system problem.	Inspect system/repair.
	C. Incorrect gas pressure.	See Sections 2.8, Gas Line Connection and 2.10, Gas Pressure Setting & Adjustment .
FRYER HEATS SLOW: HEAT light OFF/ON CONTINUOUSLY . Short cycling	A. Low voltage.	Check incoming power supply & connections.
	B. Variable temp sensor is touching, or too close to heat exchanger ring.	Correct probe location.
	C. Faulty cooking controller.	Replace controller.
	D. Loose wiring.	Inspect wiring and repair.
OIL TEMPERATURE ERRATIC:	A. Faulty variable temp sensor.	Replace faulty probe.
	B. Burner system problem.	Inspect system/repair.
	C. Faulty cooking controller.	Replace controller.
	D. Loose wiring.	Inspect wiring and repair.

6.1 Temperature Control System - continued

Problem	Probable Cause	Repair Procedure
OIL SMOKING:	A. Cooking oil is old.	Change cooking oil.
	B. Cooking temp too high.	Check settings.
	C. Low oil level.	Maintain oil at [FULL] level.
	D. Cooking oil has been contaminated.	Change cooking oil.

6.2 Oil Filtration System

Problem	Probable Cause	Repair Procedure
OIL NOT RETURNING TO FRY POT AFTER FILTERING:	A. SELECTOR switch not placed in [FILTER PUMP] position.	Place switch in proper position.
	B. Air leak in system piping.	Check hoses & connections.
	C. Faulty pump motor.	Inspect; replace if needed.
	D. Pump head clogged or bound.	Remove head cover; clean out pump as needed.
	E. <i>Diverter Valve</i> not in [FRYER] position.	Place valve handle in proper position.
	F. Oil has congealed inside pump head.	Run clean hot oil through system.
	G. Oil is too cold to be pumped efficiently (below 200°F/93°C).	Remove filter pan from fryer and manually remove cold oil.
	H. Filter Pan is assembled incorrectly.	Assembly Filter Pan correctly; see Section 5.2.
	I. Pump has been damaged by pumping boil-out solution.	Disassemble pump head ... clean & re-oil.

6.3 Basket Lift System

Problem	Probable Cause	Repair Procedure
BASKET LIFT DOES NOT OPERATE: <u>After Lift moves, it will not move again for 20 secs.</u>	A. Power is not ON .	Place POWER switch in [ON] position.
	B. BASKET key or Keypad Arrow keys [2 & 8] on controller are faulty.	Perform key function diagnostics.
	C. Cook cycle is running.	Cancel running cycle.
	D. Elevator micro-switches out of adjustment.	Adjust switches.
	E. Oil temp has not yet reached setpoint during PREHEAT .	Allow oil to heat to setpoint and fryer to enter READY state.
	F. Basket Lift motor is faulty.	Inspect, replace if needed.
	G. Controller is faulty.	Check; replace if needed.
	I. Loose wiring in lift control circuit.	Inspect; repair as needed

7. Parts List

This section lists various parts that are typically field replaceable on GGF Gas Fryers. It is provided to aid qualified service technicians who are servicing or repairing this equipment. Equipment repairs should only be attempted by training kitchen equipment service technicians.

7.1 Parts Ordering & Service Information

Giles is an equipment manufacturer & does not sell parts direct. Parts are available through authorized service agents, part distributors, or kitchen equipment dealers. If assistance with sourcing parts or equipment repair service is required, please contact a GILES Manufacturer’s Representative to assist with locating a parts source or authorized service provider near you. For further assistance you may contact the **GILES Technical/Customer Service Support** team as follows:

IN THE UNITED STATES & CANADA call: 800.554.4537

ALL OTHERS call: 334.272.1457

Normal business hours are 8:00 AM to 5:00 PM Central Time ... calls are handled by an automated answering system. Please follow the recorded instructions to reach the appropriate support associate. If necessary after hours, leave a detailed voicemail message including contact info ... a representative should respond within 30 minutes.

Website: www.gfse.com Email: services@gfse.com

Our goal at Giles is to provide the highest possible quality of service & assistance. To help us accomplish this, please have the following information readily available when calling, along with a brief description of the problem being experienced. Please record your unit’s information in the table below for quick reference.

Model:	
Serial Number:	
Voltage:	
Phase:	



The information can be found on the Serial/Data Label located inside the Fryer cabinet, or on the rear cabinet panel.

7.2 Front Header & Control Panel

FRONT HEADER PANEL

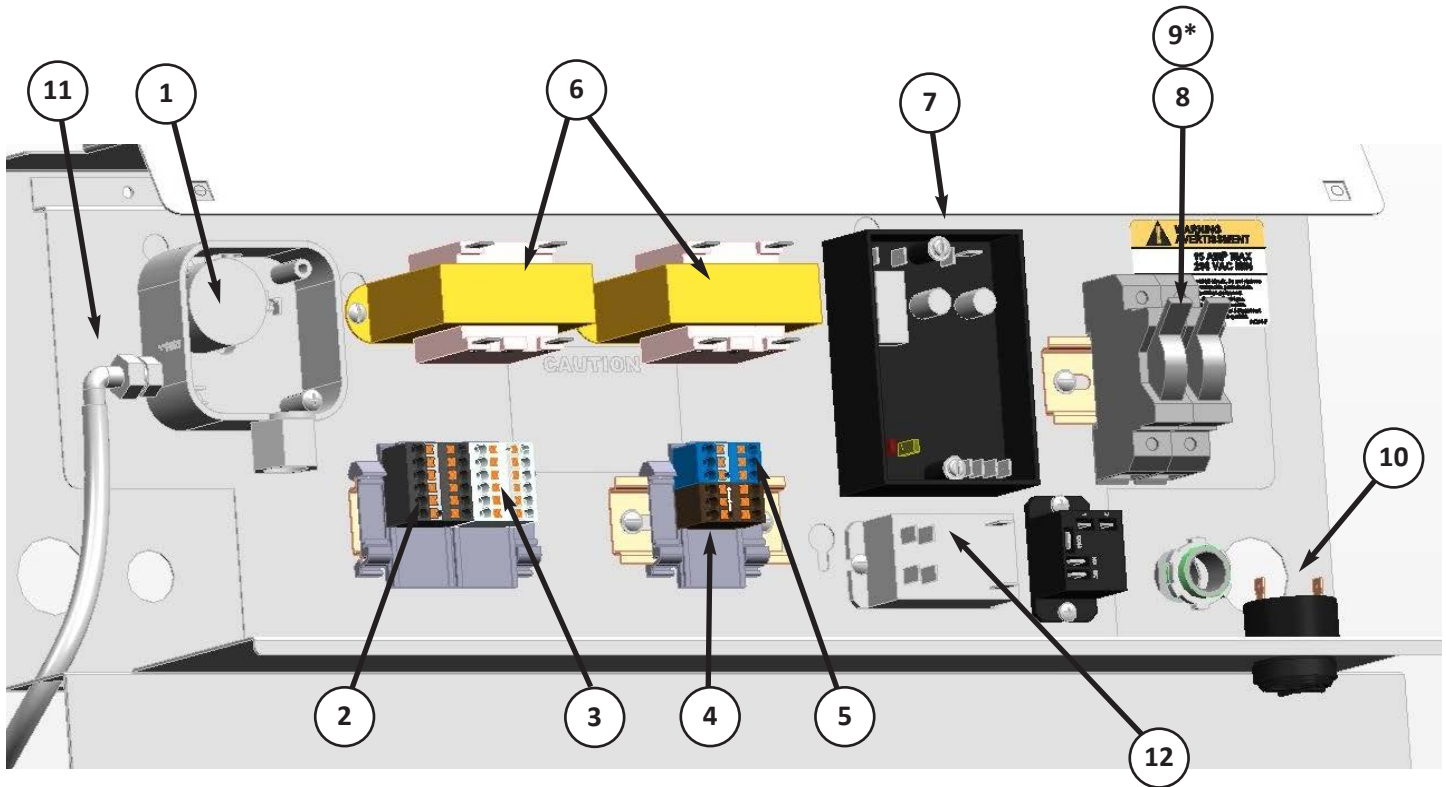

FRONT CONTROL PANEL

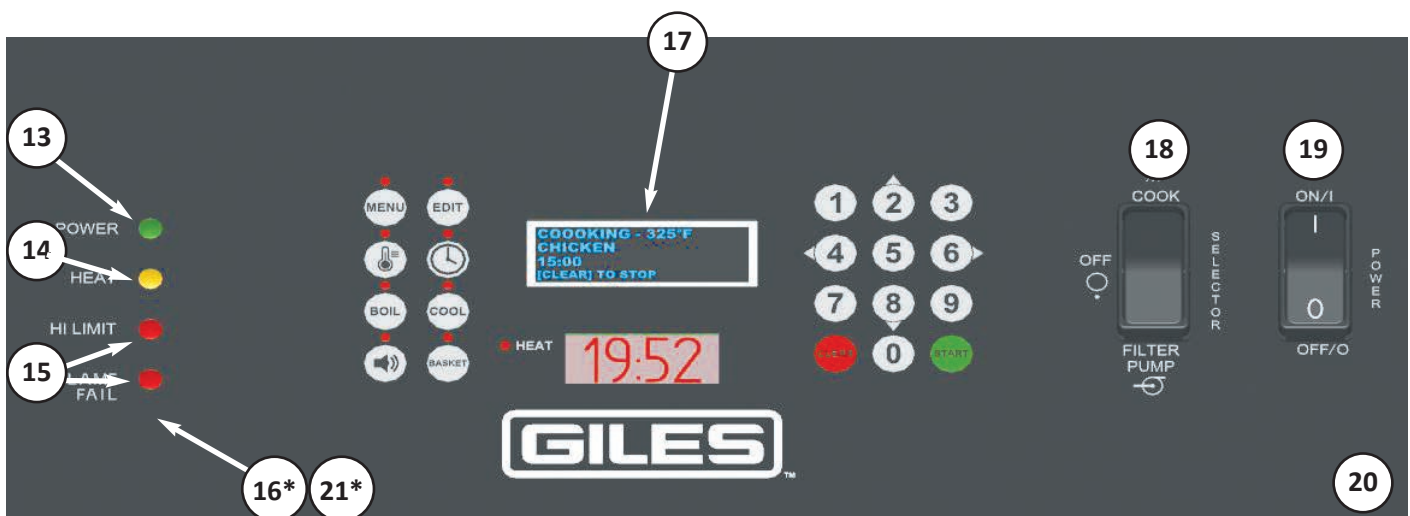

* Not Shown

7.2 Front Header & Control Panel

Item	Part Number	QTY.	Description
1	20390	1	SWITCH, VACUUM
2	21510	2	TERMINAL BLOCK
3	21511	2	TRANSFORMER, 24VAC
4	21735	2	TERMINAL BLOCK
5	21508	2	TRANSFORMER, 24VAC
6	24276	2	TRANSFORMER, 24VAC
7	21568	1	THERMOSTAT, HI-LIMIT, 425DEG
8	20411	1	FUSE HOLDER, DIN RAIL MOUNT
9*	21693	1	FUSE, 15A, CC, 1.5"
10	23782	1	SONALERT
11	40877	1	FITTING, 1/4 BARBED, 90-EL, NYL, 1/8 NPT
12	21423	1	RELAY, POWER SWITCH, 30A/2.5HP
13	21678	1	INDICATOR LIGHT, GREEN
14	21682	1	INDICATOR LIGHT, AMBER, LED, 28V
15	21683	2	INDICATOR LIGHT, RED, LED, 28V
16*	97137	1	HOLDING BRACKET, INDICATOR LIGHTS
17	21374	1	COMPUTER CONTROLLER, CC10
18	21189	1	SWITCH, ROCKER, ON-OFF-ON, 250V,20A,S.P.
19	21190	1	SWITCH, ROCKER, ON-OFF, 250V, 20A, D.P.
20	66131	1	LABEL, CONTROL PANEL, CC10, GGF
21*	97138	2	SPACER, INDICATOR HOLDER

* Not Shown

7.3 Front Lower Cabinet

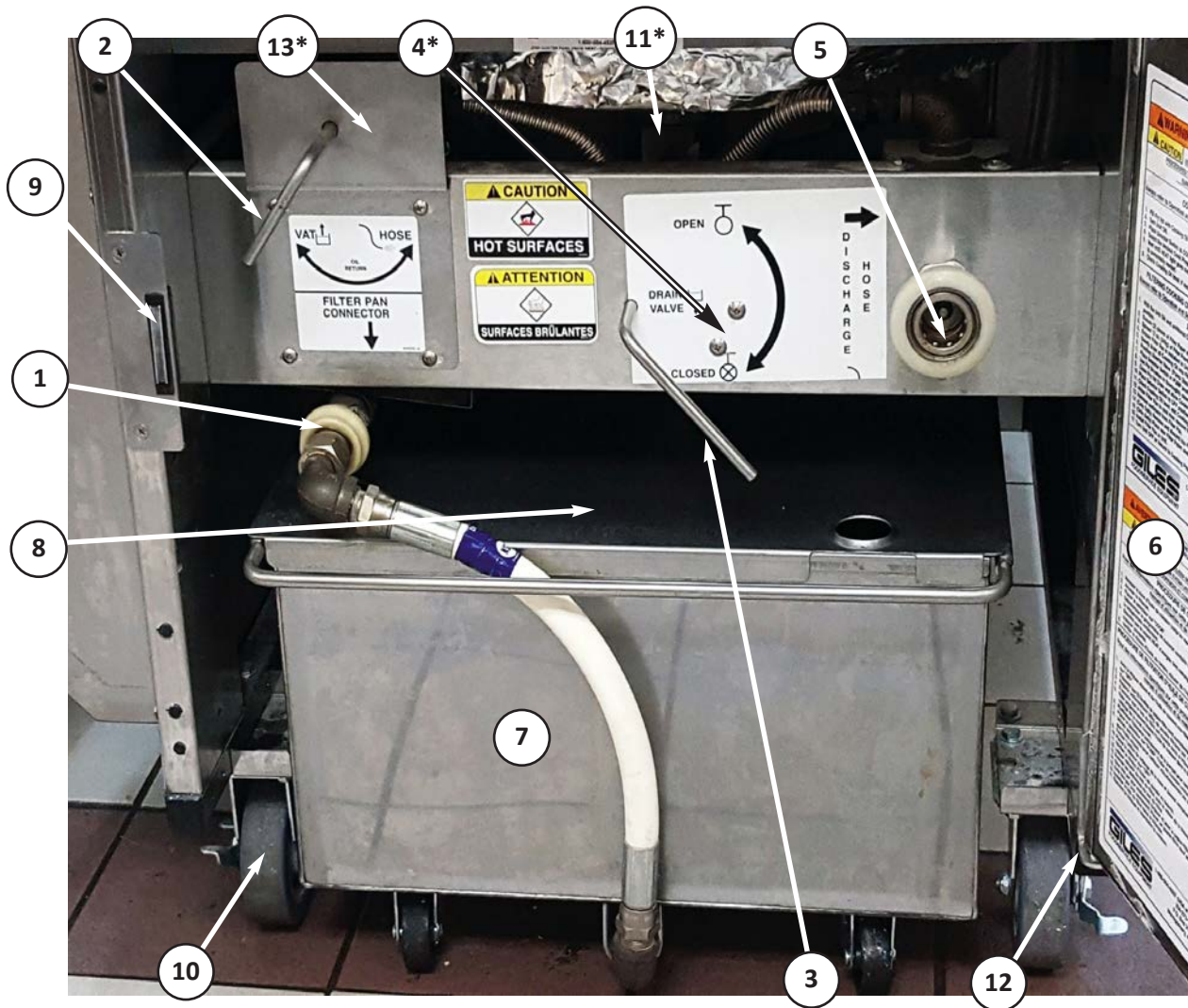

* Not shown

7.3 Front Lower Cabinet

Item	Part Number	Qty	Description
1	41900	1	COUPLING, QUICK DISCONNECT, FEMALE, FILTER PAN
2	35108	1	DIVERTER VALVE HANDLE, WELD ASSY
3	80310	1	VALVE HANDLE, PROX DRAIN VALVE, WELD ASSY, GGF
4*	21502	1	SWITCH, PROXIMITY, INDUCTIVE, 24-240V
5	41699	1	COUPLING, QUICK DISCONNECT, FEMALE, DISCHARGE HOSE
6	38845	1	DOOR, WELD ASSY, GGF
7	91823	1	FILTER PAN, ASSEMBLY, GGF
8	95555	1	FILTER PAN COVER, GEF/GGF
9	40851	1	CATCH, MAGNET, DOOR, SNAP IN, 2.3IN
10	40806	2	CASTER, 5.000, RIGID, W/BRAKE, GEF
11*	45876	1	DRAIN VALVE, 1-1/2"NPT, GGF
12	90943	2	DOOR HINGE PIN, WELD ASSY, GGF
13*	45755	1	VALVE, 3-WAY, 1/2-NPT, NICKEL PLATED

* Not shown

7.4 Rear Cabinet

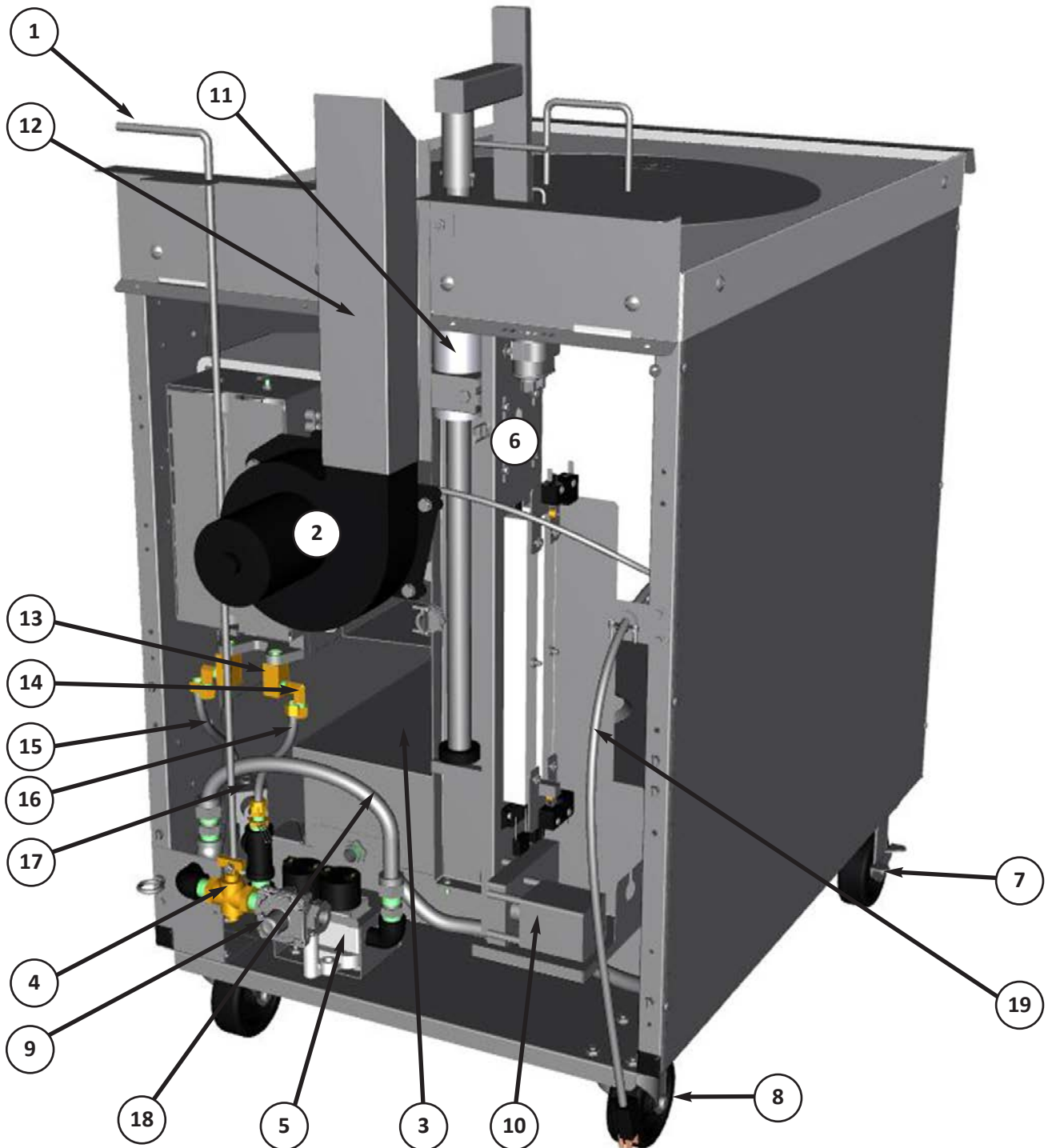

7.4 Rear Cabinet

Item	Part Number	Qty.	Description
1	90893	1	HANDLE, GAS SHUT OFF VALVE
2	20440	1	BLOWER, DRAFT, 115V (GGF-720, NAT. GAS)
	21801	1	BLOWER, DRAFT, 115V (GGF-720. LP GAS + ALL GGF-400)
3	95555	1	COVER, FILTER PAN
4	34955	1	GAS COCK, SHUTOFF VALVE
5	45108	1	GAS CONTROL VALVE
6	91186	1	ELEVATOR ASSEMBLY, 120V
7	40806	2	CASTER, 5.0, RIGID W/BRAKE
8	40807	2	CASTER, 5.0, SWIVEL W/O BRAKE
9	41468	1	REGULATOR, PRESS, NAT. GAS, 1/2-NPT
	41472	1	REGULATOR, PRESS, LP GAS, 1/2-NPT
10	20423	1	MOTOR, ELEVATOR, 115V
11	40770	1	SHAFT & CYLINDER ASSY, ELEVATOR
12	90882	1	FLUE PIPE (ALL GGF-400 + GGF-720, LP)
	91493	1	FLUE PIPE (GGF-720, NAT)
*13	46727	1 or 2	GAS ORIFICE MANIFOLD (GGF-400 = 1; GGF-720 = 2)
14	40920	2	90° FITTING, BRASS, 3/8 CMPRSS to 1/4 NPT (GGF-720 ONLY)
15	40912	1	GAS LINE, 3/8 OD X 10-1/4, CMORSS w/NUTS (GGF-400; GGF-720)
16	40911	1	GAS LINE, 3/8 OD X 7-1/8, CMORSS w/NUTS (GGF-720 ONLY)
17	40890	1	SOLENOID VALVE, N/C, 24VAC, 2-WAY (GGF-720 ONLY)
18	40909	1	HOSE, CORRUGATED, SS, 1/2 ID X 15
19	21285	1	CORDSET, 120V, 8-FT W/PLUG, SJOW

* See Section 2.9, *Gas Orifice Installation & Replacement*. Table shows Gas Orifice part numbers for various elevations. Factory-installed orifices are satisfactory for use at: 0-3000 ft AMSL (Nat gas) & 0-4000 ft AMSL (LP gas).

7.5 Plumbing - Standard

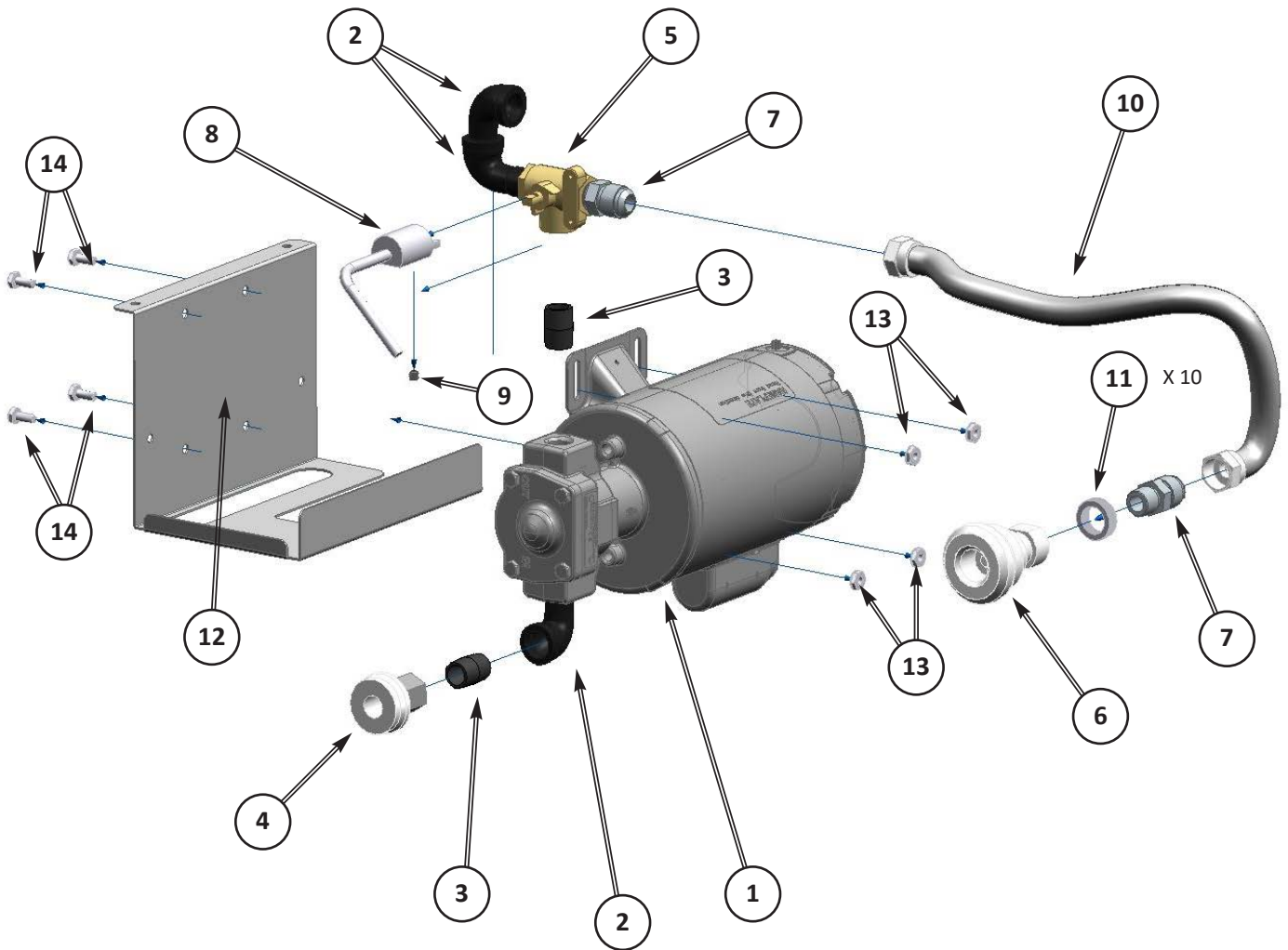

7.5 Plumbing - Standard

Item	Part Number	Qty.	Description
1	71754	1	PUMP & MOTOR ASSY, 5-GPM, 1/2 HP
	76923	1	PUMP HEAD ONLY, 5-GPM
	71824	1	MOTOR ONLY, 1/2 HP
2	42250	3	STREET ELL, BLACK, 1/2"
3	43850	2	NIPPLE, 1/2" CLOSE
4	41900	1	QUICK DISCONNECT, 1/2"
5	45755	1	3-WAY VALVE
6	41699	1	COUPLING, FEMALE QUICK DISCONNECT
7	40889	2	ADAPTER, 1/2" COMPRESSION X 1/2" PIPE THREAD -
8	35108	1	VALVE HANDLE, DIVERTER VALVE
9	10098	1	SET SCREW, 1/4-20 X 1/4, SOC HD, CUP PT
10	41080	1	HOSE, CORRUGATED, SS, 1/2 ID X 30
11	10524	10	WASHER, .843 X 1.190 X .036, THK
12	99987	1	BRACE, SIDE, PUMP MOUNTING
13	10537	4	NUT, 1/4-20 HEX, SERRTD FLANGE, SS
14	12450	4	SCREW, 1/4-20 X 0.625, HEX HD, ZINC

* NOTE: Units manufactured before **2015** may still have a 1/3 hp pump & motor - **#70912** (Pump Head - **#70910**, Motor - **#70911**). These parts are **no longer available** ... the parts listed in **Item #1** above should be direct replacement. Contact factory for further information ... **800.554.4537**

7.6 Plumbing - Waste Oil Option

Item	Part Number	Qty.	Description
1	71754	1	PUMP & MOTOR ASSY, 5-GPM, 1/2 HP
	76923	1	PUMP HEAD ONLY, 5-GPM
	71824	1	MOTOR ONLY, 1/2 HP
2	42250	6	STREET ELL, BLACK, 1/2"
3	43850	2	NIPPLE, 1/2" CLOSE
4	41900	1	QUICK DISCONNECT, 1/2"
5	45755	2	3-WAY VALVE
6	41699	1	COUPLING, FEMALE QUICK DISCONNECT
7	40889	5	ADAPTER, 1/2" COMPRESSION X 1/2" PIPE THREAD -
8	35108	2	VALVE HANDLE, DIVERTER VALVE
9	40909	1	HOSE, CORRUGATED, SS, 1/2 ID X 15
10	41079	1	HOSE, CORRUGATED, SS, 1/2 ID X 08
11	10524	10	WASHER, .843 X 1.190 X .036, THK
12	10098	2	SET SCREW, 1/4-20 X 1/4, SOC HD, CUP PT
13	99966	1	BRACKET, WAND/WASTE OIL VALVE
14	12275	2	WASHER, 1/4, LOCK, ZINC
15	12650	2	NUT, 1/4-20, CAP, SS
16	99970	2	STANDOFF, DIVERTER VALVE
17	99987	1	BRACE, SIDE, PUMP MOUNTING
18	10537	4	NUT, 1/4-20 HEX, SERRTD FLANGE, SS
19	12450	4	SCREW, 1/4-20 X 0.625, HEX HD, ZINC

7.7 Basket & Basket Cover

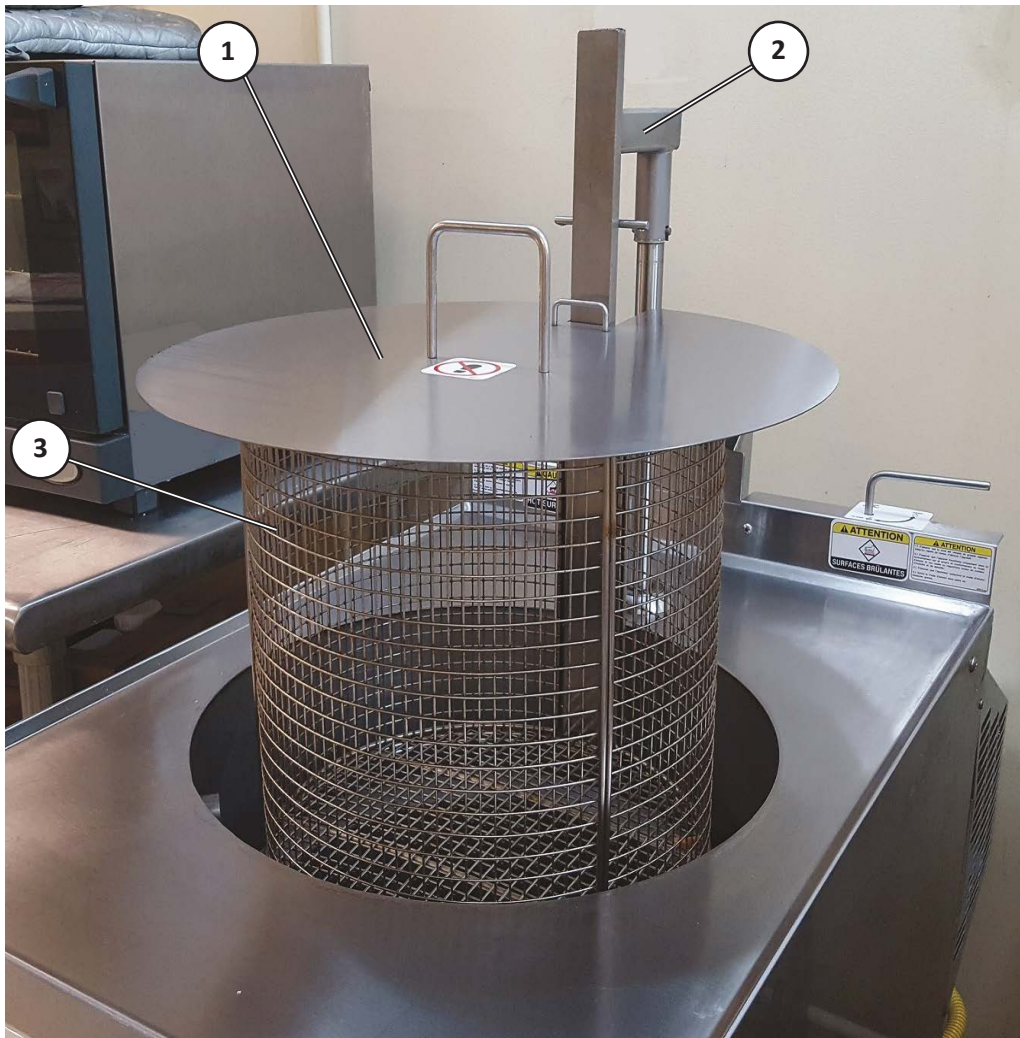

7.7 Basket & Basket Cover

Item	Part Number	Qty.	Description
1	33883	1	BASKET COVER, ASSY, GGF-720
	33884	1	BASKET COVER, ASSY, GGF-400
2	38930	1	BASKET CARRIER, ASSY, GGF-720
	39165	1	BASKET CARRIER, ASSY, GGF-400
3	91811	1	BASKET, GGF-720
	33718	1	BASKET, GGF-400

7.8 Filter Pan

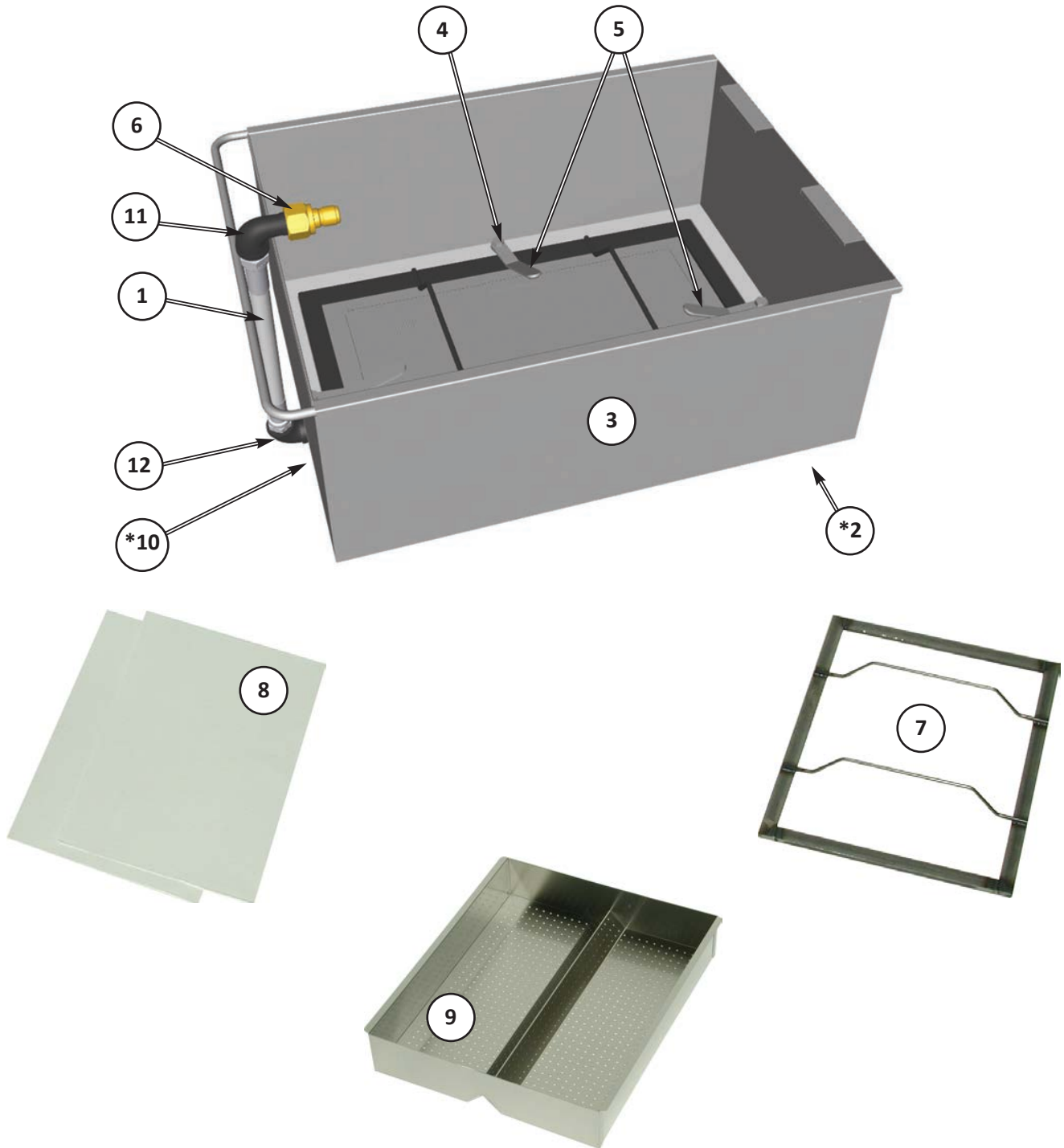

+ Optional Accessory
Purchased Separately

* Not shown

7.8 Filter Pan

Item	Part Number	Qty.	Description
1	40955	1	HOSE, 1/2NPT X 15.75
* 2	40649	4	CASTER, SWIVEL, 2-9/16, FILTER PAN
3	91823	1	FILTER PAN, COMPLETE ASSEMBLY
4	30040-4	4	STUD, FILTER PAN HOLD DOWN FRAME
5	38841	4	HANDLE, SUPPORT FRAME, FILTER PAN, GGF
6	44150	1	FITTING, BRASS, MALE, 1/2NPT, QUICK DISCONNECT
7	38830	1	HOLD DOWN FRAME, WELD ASSY
8	60810	1	PAPER, FILTER, 21.375 X 15.500, GGF
+ 9	39246	1	CRUMB SCREEN, FILTER PAN, GGF
* 10	40956	1	HOSE, 1/2NPT X 11.500
11	42250	1	ELL, BLACK, STREET, 1/2, 90-DEG
12	42200	1	ELL, BLACK, 1/2, 90-DEG

* Not shown

+ Optional Accessory, Purchased Separately

Item 3, Complete Filter Pan Assembly DOES NOT include Optional Item 9, Crumb Screen

Notes

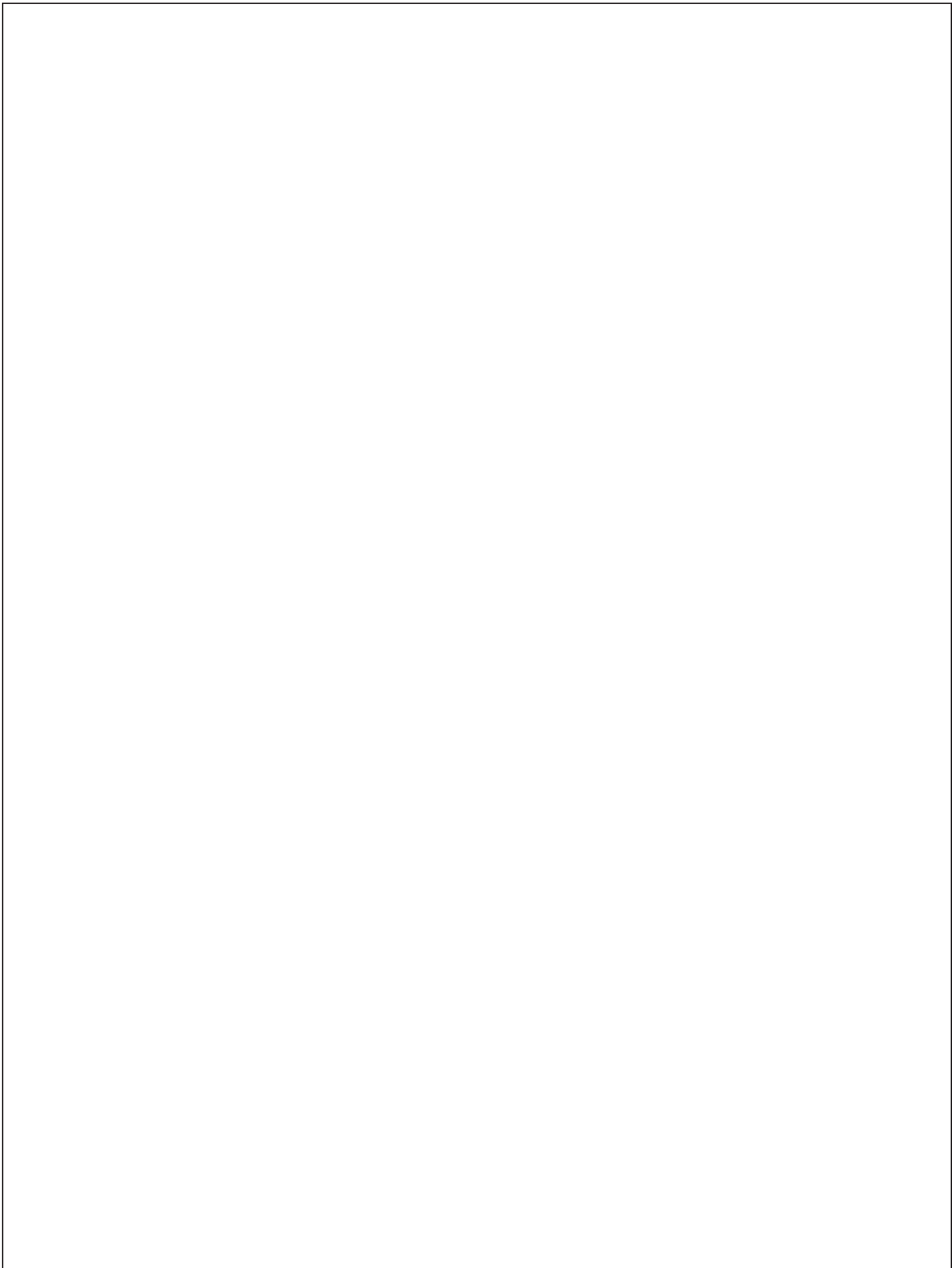



GILES Food Service Equipment

ISO 9001-2015 Certified

2750 Gunter Park Drive West • Montgomery, AL 36109 USA
Phone 334.272.1457 • Fax 334.239.4117 • Phone Toll Free 800.554.4537
Website: www.gfse.com • Email: services@gfse.com

65474
REV-K
ECO3459
6/11/2025
PRINTED IN USA