

## Operation & Service Manual



### XPressFry GXF



**CAUTION:** Read instructions before using this appliance.

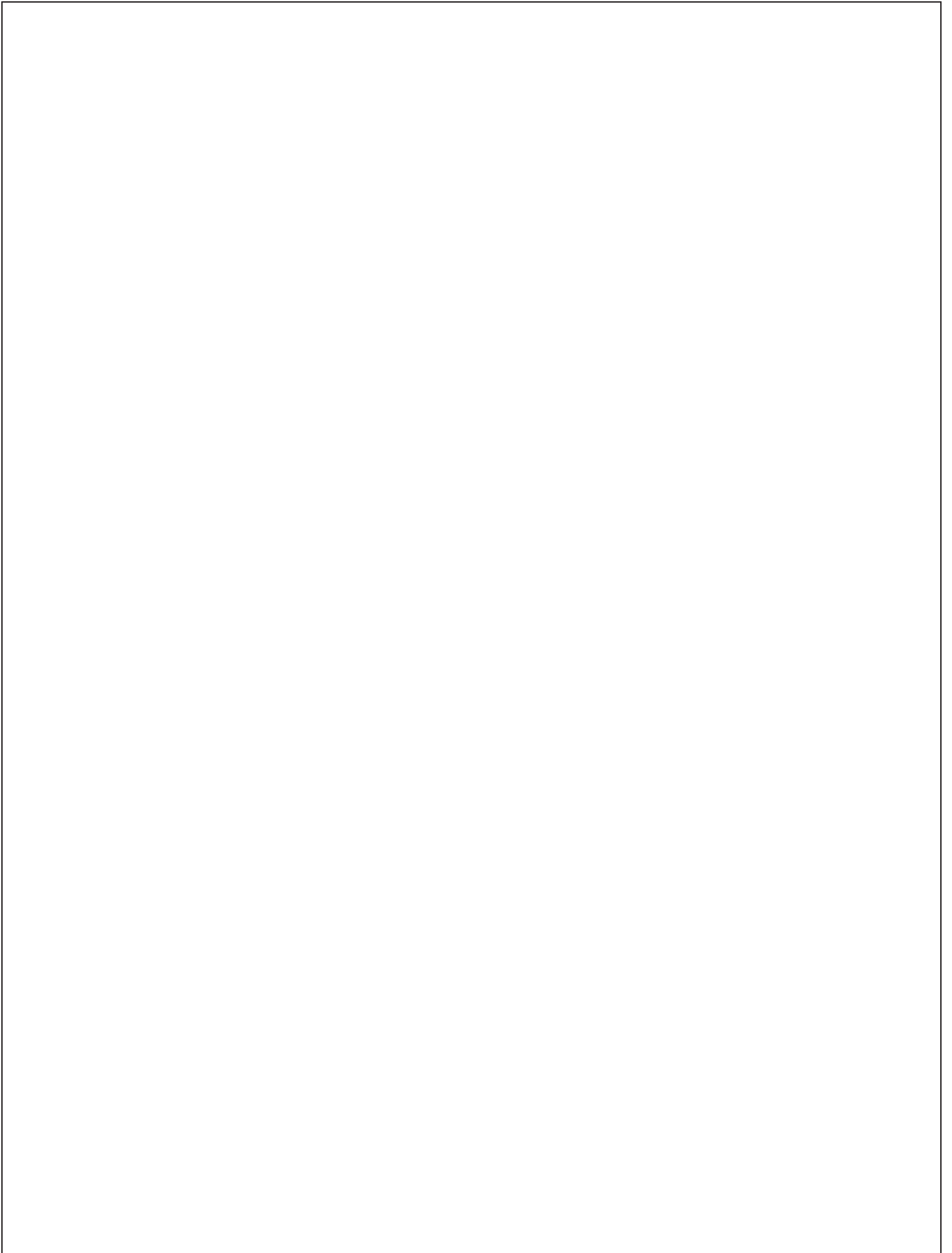



## LIMITED WARRANTY

- Subject to the terms and conditions of this Limited Warranty as herein stated, all Giles Enterprises Inc. (hereafter referred to as "Giles") food service equipment and parts purchased new from an authorized Giles representative are warranted as to defects in material or workmanship for a period of twenty-four (24) months from the date of installation, provided, however, that with regard to labor costs in connection with this warranty, see below. All installations must be made by a qualified installing agency in accordance with all applicable codes and/or regulations in the jurisdiction in which installed. Limited warranty coverage is extended only to the original owner and is void if the unit is resold.
- During the Limited Warranty period, Giles will replace or recondition, at its factory, any part or parts of this unit which Giles inspectors judge defective, provided the unit has been properly installed, subjected to normal usage, and operated and maintained in accordance with specified procedures. This Limited Warranty does not cover cosmetic damage, and damage due to acts of God, accident, misuse, alteration, negligence, abuse, or use of unorthodox repair methods. All parts replaced under this Limited Warranty carry only the unexpired term of this Limited Warranty. Limited Warranty service may be furnished only by an authorized Giles service representative.
- If Limited Warranty service is requested, Giles will dispatch factory-authorized service representatives to inspect, repair, recondition, or replace units of its manufacture with such labor being rendered without cost to owner for twenty-four (24) months from the date of installation. Otherwise, service, including labor and transportation charges or other expenses, in connection with the removal or installation of any part or parts supplied under this Limited Warranty, are specified on the original sales contract between the purchaser and the authorized Giles representative.
- **Failure to use Giles OEM replacement parts and Giles OEM filters may void this Warranty.**
- Giles reserves the right to change or improve its equipment and/or parts in any way without obligation to alter such equipment or parts previously manufactured.
- Giles makes no further warranties, express or implied, including implied warranties of merchantability or fitness for a particular purpose, and has no other obligation or liability not specifically stated herein.
- Repair or replacement as provided under this limited warranty is the exclusive remedy. Giles shall not be liable for any incidental or consequential damages for breach of any express or implied warranty on this product, except to the extent prohibited by applicable law. Any implied warranty of merchantability or fitness for a particular purpose on this product is limited in duration to the duration of this limited warranty.
- Used Giles food service equipment or parts, or Giles food service equipment or parts not purchased from an authorized Giles representative, carry no warranties, express or implied.

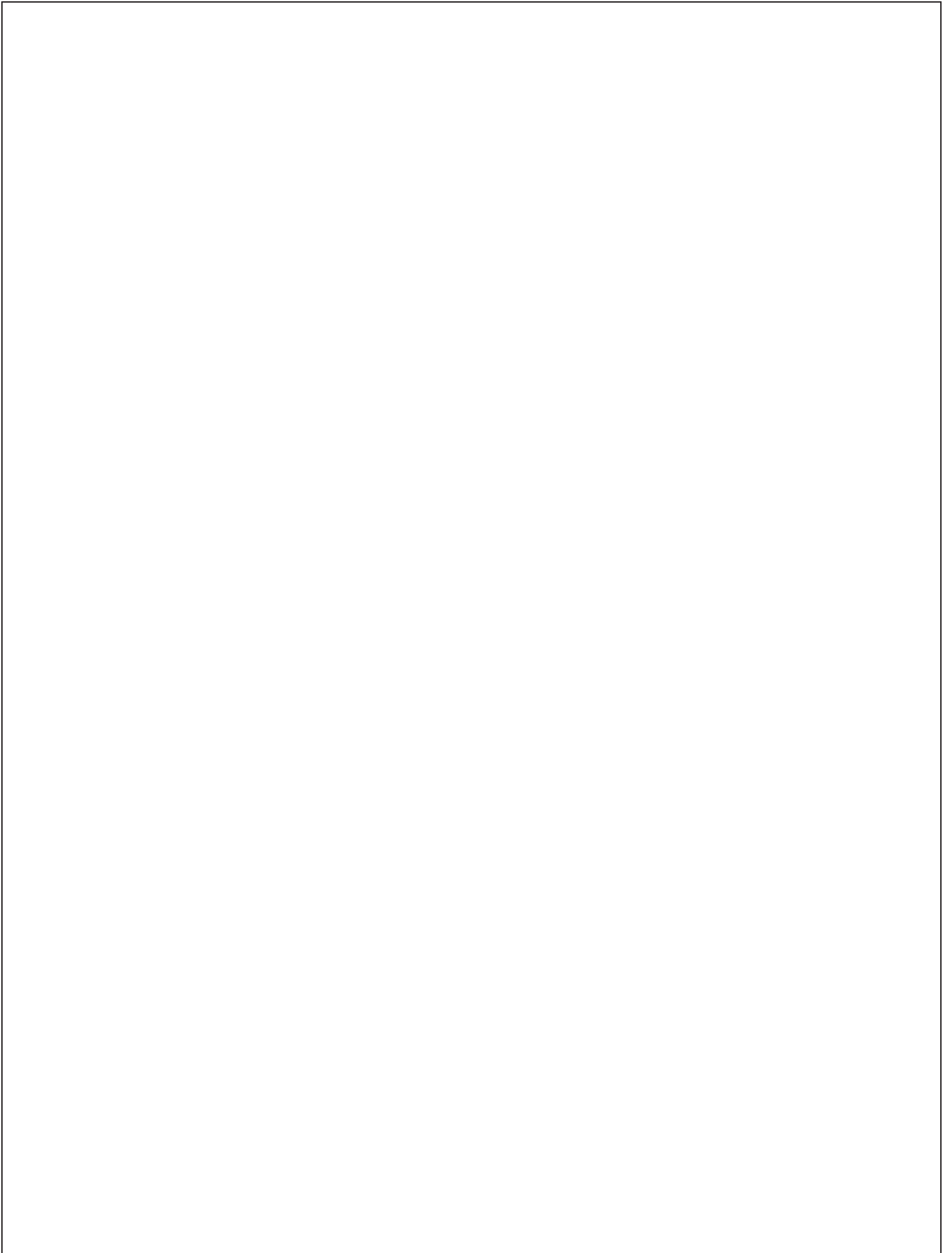

<b>Safety</b> .....	<b>iii</b>
Safety Overview .....	iii
Specific Safety Precautions .....	iv
<b>1. Introduction</b> .....	<b>1</b>
1.1. Construction .....	1
1.2. Standard Features .....	1
1.2.1. Optional Features .....	1
1.3. Specifications .....	2
1.3.1. Overall Dimensions .....	2
1.3.2. Electrical Specifications .....	3
1.3.3. Agency Certifications .....	3
1.3.4. Unit Weight .....	3
1.3.5. Capacities .....	3
<b>2. Installation</b> .....	<b>5</b>
2.1. Appliance Location .....	5
2.2. Electrical Preparation .....	5
2.3. Unpacking .....	6
2.4. Adjustable Leg Installation .....	6
2.5. Electrical Requirements .....	7
2.5.1. Electrical Service .....	7
2.6. Appliance Placement .....	8
2.7. Initial Cleaning .....	8
2.8. Wet Chemical Automatic Fire Extinguisher .....	9
2.9. Air Cleaning Filters .....	9
2.10. Service Connection .....	10
2.11. Clearance .....	10
2.12. Preparing the Vat .....	11
2.13. Initial Power-up .....	12
<b>3. Operation</b> .....	<b>13</b>
3.1. Appliance Overview .....	13
3.1.1. Appliance Exterior .....	14
3.1.2. Cabinet, Cooking Chamber .....	16
3.1.3. Appliance Accessories (Included) .....	18
3.1.4. Appliance Accessories (Not Included) .....	19
3.2. Controller Overview .....	20
3.3. Start-up/General Operation .....	22
3.4. Working with Menu Item Presets .....	23
3.4.1. Editing a Menu Preset .....	24
3.4.2. Selecting a Menu Preset for Cooking .....	26
3.5. Setting a Manual Cooking Time and Temperature .....	27
3.6. Other Controller Features .....	28
3.6.1. COOL Mode .....	28
3.6.2. AUTOCOOL Feature .....	28

3.6.3.	CLEAN Mode . . . . .	28
3.6.4.	PASSWORD Protection . . . . .	29
3.7.	User Settings - Access and Edit . . . . .	29
3.8.	Controller Errors and Alarms. . . . .	31
3.8.1	Resolving Controller Errors and Alarms . . . . .	32
3.9.	XPressFry Cooking Procedures . . . . .	34
3.9.1.	Cancelling a Running Cook Cycle . . . . .	35
3.10	Sleep Mode/Power-off. . . . .	36
3.11.	High Temperature Safety Shutdown (Hi-Limit Tripped) . . . . .	36
3.12.	Resetting the High-Limit Safety Thermostat . . . . .	37
<b>4.</b>	<b>Filter Maintenance . . . . .</b>	<b>39</b>
4.1.	General Information . . . . .	39
4.2.	Filter Table . . . . .	39
4.3.	Removing Filters . . . . .	40
4.4.	Installing Filters . . . . .	41
4.5.	Cleaning the Baffle Filter. . . . .	42
4.6.	Charcoal Filter Replacement . . . . .	42
<b>5.</b>	<b>General Maintenance . . . . .</b>	<b>45</b>
5.1.	Daily Cleaning . . . . .	45
5.2.	Weekly Cleaning . . . . .	46
5.3.	Monthly Interlock Safety Inspection . . . . .	46
5.4.	Quarterly Cleaning . . . . .	48
5.5.	Fire Extinguishing System Maintenance . . . . .	48
5.6.	Maintaining the Cooking Oil. . . . .	49
5.7.	Removing Cooking Oil from the Appliance . . . . .	49
5.8.	Refreshing Cooking Oil in the Appliance . . . . .	50
5.9.	Maintenance Log . . . . .	51
<b>6.</b>	<b>Troubleshooting . . . . .</b>	<b>53</b>
<b>7.</b>	<b>Parts List . . . . .</b>	<b>57</b>
7.1.	Parts Ordering and Service Information . . . . .	57
7.2.	Appliance Exterior. . . . .	58
7.3.	Cabinet Interior (Front) . . . . .	60
7.4.	Element Assembly Detail . . . . .	62
7.5.	Electrical Components, Right Side . . . . .	64
7.6.	Electrical Components, Rear . . . . .	66
7.7.	Fire Extinguishing System . . . . .	68

## Safety Overview

The information contained in this manual has been prepared to explain proper procedures for safely installing, operating and maintaining this *Giles XPressFry GXF Countertop Electric Fryer*.

Throughout the manual, safety precautions are identified by certain alert notifications. Important safety information will precede the processes to which it applies. Suggested, recommended, and other noteworthy information is marked as **NOTE**, or will be labeled as **IMPORTANT!**. Additionally, certain words are used to indicate a specific meaning, or to add emphasis as follows:

**Shall:** understood to be mandatory.

**Should:** understood to be advisory.

**May:** understood to be permissive.

**Will:** indicates that a future event or condition will occur.

 **Hazard Alert Symbols** are used in conjunction with notifications, such as **DANGER**, **WARNING**, or **CAUTION**, to alert users to potential personal injury hazards and/or poor operating practices. These notifications will immediately precede precautionary measures relating to avoiding the hazard or practice. Adhere to all of the stated safety precautions to avoid possible injury, even death, damage to the equipment or damaged property. Failure to do so may also void the factory warranty.

 **This product can minimally expose users to materials containing lead, nickel, aluminum, cadmium, brass, carbon, copper or BPA which are known in the state of California to cause cancer, birth defects and other reproductive harm. For more information go to: [www.p65warnings.ca.gov](http://www.p65warnings.ca.gov).**

### **DANGER**

Indicates an imminently hazardous situation which, if not avoided, will result in serious personal injury, even death.

### **WARNING**

Indicates a potentially hazardous situation which, if not avoided, could result in serious injury, even death.

### **CAUTION**

Indicates a potentially hazardous situation (*or unsafe practice*) which, if not avoided, may result in minor to moderate injury.

### **CAUTION**

Used without the safety alert symbol, indicates a potentially hazardous situation which, if not avoided, may result in equipment damage and/or damage to property, and may void the factory warranty.

### **NOTE or IMPORTANT!**

Identifies suggested, recommended, or other important information.

## Specific Safety Precautions:

Please observe all of the following precautions when operating or servicing this *GILES* food service equipment. Adhering to the following important safety information will help to prevent personal injury and/or damage to the equipment or property.

### **DANGER**

- Before cleaning or performing maintenance, place power switch in the **OFF** position. Unplug power cord or turn **OFF** power at the electrical panel supplying power to remove all power from the appliance.
- **DO NOT** wash down equipment with water spray.
- Failure to comply with **DANGER** notices will result in serious injury, even death; or damage to equipment and/or property and may void the factory warranty.

### **WARNING**

- Prior to installation, consult a qualified electrician to ensure that installation complies with all electrical requirements and codes.
- **The unit must be adequately and properly grounded. Improper grounding may result in electrical shock to User. Always refer to local electrical code to ensure proper grounding of this or any other electrical equipment.**
- **Check the rating label on the unit to determine the proper power supply required. Always consult with an electrician, or other qualified service technician, to ensure that circuit breakers and wiring are of sufficient rating and gauge to power this equipment. A Wiring Diagram has been provided with the unit as an aid for technicians. Appliance must be installed and electrically grounded in accordance with local code, or in the absence of local code, in accordance with the National Electrical Code, NFPA 70.**
- Improper installation, adjustment, alteration, service, or maintenance could result in serious injury, even death; equipment and/or property damage; and will potentially void the factory warranty.
- **DO NOT** use or store flammable liquids, or materials that produce flammable vapors, in the vicinity of this or any other appliance!
- Failure to comply with **WARNING** notices could result in serious injury, even death; damage to equipment and/or property; and will potentially void the factory warranty.

## CAUTION

- The appliance must remain in an upright position.
- Exercise care when removing the unit from shipping pallet.
- **DO NOT** operate the appliance, unless its components and their intended functions are fully understood (see **Section 3**). After reading and fully understanding **Section 3**, closely follow the presented procedures and instructions in order to avoid equipment damage or malfunction.
- **To avoid personal injury, it is recommended that thermal hand protection (gloves or mitts) be worn while tended the appliance.** Certain parts of the Fryer will become very **HOT** during operation; temperatures inside cabinet may exceed **150°F (65.5°C)**! Exercise caution when operating and cleaning.
- The **XPressFry** is intended for countertop operation. Choose a counter location that is sturdy, level, easily cleanable and fire resistant. Stainless steel, fire resistant laminate, or solid stone-type materials are acceptable. Securely anchor the appliance to the counter using the provided mounting plates on the adjustable legs. **DO NOT** operate if not secured.
- Some parts of this appliance become extremely **HOT** during operation. Temperatures inside the unit can exceed 375°F (190.6°C). Due caution is required when operating, cleaning, or servicing to avoid personal injury. Allow the appliance to cool (**15 - 20 mins minimum**) before cleaning or servicing and wear thermal protection, such as oven mitts or gloves, when handling removeable parts.
- This appliance is not intended for use by persons (including children) with reduced physical, sensory, or mental capabilities, or lack of experience and knowledge, unless they have been given adequate instruction and/or supervision concerning its use by a person responsible for their safety. Children should not be allowed to play with, or around, this appliance.
- Prior to sale, cooked food products must be maintained at a minimum temperature of 150°F (65.5°C), or in accordance with governing health regulations
- Failure to comply with **CAUTION** notices may result in minor to moderate personal injury, damage to equipment or property, and potentially void the warranty.

## CAUTION

- The face of the appliance Controller is somewhat impact-sensitive. Exercise care when operating or cleaning. **DO NOT** clean Controller face with harsh or abrasive cleaners. Always operate the Controller keys with the fingers...**DO NOT** use hard objects of any kind.
- **DO NOT** install the appliance in any location that has **less than 8" (203 mm)** of overhead clearance from top of unit. Failure to maintain safe distances may result in fire or reduce the effectiveness of the air filtration system.
- When cleaning the appliance:
  - **DO NOT** steam clean or spray with water.
  - **DO NOT** use products containing chlorine, or other corrosive chemicals.
  - **DO NOT** use abrasive products, steel wool or scouring pads.
  - **DO NOT** use oven cleaners.
- **DO NOT** add attachments, or otherwise modify the equipment! **DO NOT** attach any type of ductwork to the hood exhaust outlet in an attempt to redirect airflow.
- Failure to comply with **CAUTION** notices may result in damage to equipment or property. Such damages are **NOT** covered by the factory warranty.

## NOTE:

- Comply with all appropriate state and local health regulations regarding the cleaning and sanitization of this appliance, and holding of cooked foods awaiting sale.
- When in operation, the sound level of the hood fan is approximately 45 dB.
- Never attempt to clean and re-use the Charcoal Filter.
- The fire extinguisher discharge nozzles have been factory installed in the proper operating position. **DO NOT MOVE or ADJUST.**

## 1. Introduction

Thank you for purchasing the **XPressFry, GXF Automatic Countertop Electric Fryer** manufactured by *Giles Enterprises, Inc.*, Montgomery, Alabama, USA, hereafter referred to as “Giles”. Every unit is thoroughly inspected and tested prior to shipment, and with proper care and maintenance it will provide years of trouble-free service.

After completion of a few installation and set-up procedures you will be ready to begin using this state-of-the-art appliance. Please take a few moments to become familiar with the procedures described in this Manual concerning installation, operation, cleaning and maintenance of the appliance and you’ll be cooking in no time.

To help protect your investment, we recommend that you take the time to review this Manual and become familiar with the procedures pertaining to installation, operation, cleaning and maintenance. Adherence to recommendations will minimize potential for costly “downtime” and future repair expense. **Please retain this Manual for future reference.**

### NOTE:

Giles is not responsible for obtaining required approvals from local authorities having jurisdiction related to the use of this appliance in the intended location, or for complying with local requirements for other additional equipment and/or appliances, which may be required for operation of a food preparation area in a commercial establishment. Check with local officials for specific requirements.

*Due to continuing improvements and product enhancements, some illustrations shown in this Manual might not exactly depict your actual equipment.* **NOTE:**

## 1.1 Construction

Constructed of high-grade stainless steel sheet metal.

## 1.2 Standard Features

**Controller** - micro-processor appliance control ... adjustable oil temperature set-point ... fifty (50) programmable menu item presets ... energy-saving **COOL Mode & AUTOCOOL** feature; **CLEAN Mode**; Password protection; multiple-language options.

**Automatic Cooked Food Unloading** - automatically drains and dumps cooked product into holding pan.

**Ventless Air Filtration** - stainless steel Baffle Filter and high capacity Activated Carbon Filter removes grease-laden vapor and cooking odor from exhaust air, allowing it to be recirculated into the room ... no need to vent outside.

**Fire Extinguishing System** - completely self-contained fire extinguishing system with high volume wet chemical cylinder ... ensures complete extinguishing of accidental oil fire and significantly minimizes re-ignition potential.

### 1.2.1 Optional Features

**Side Chute** - Easily switch from front delivery of cooked product to left or right side delivery with the optional side chute.

## 1.3 Specifications

### 1.3.1 Overall Dimensions

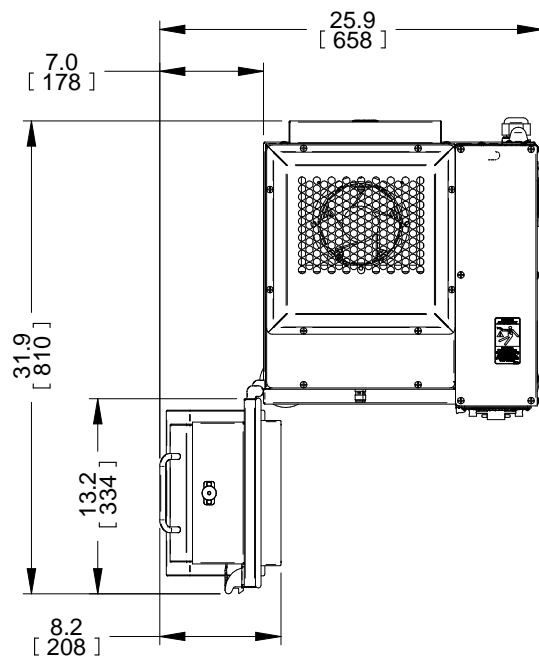

TOP VIEW

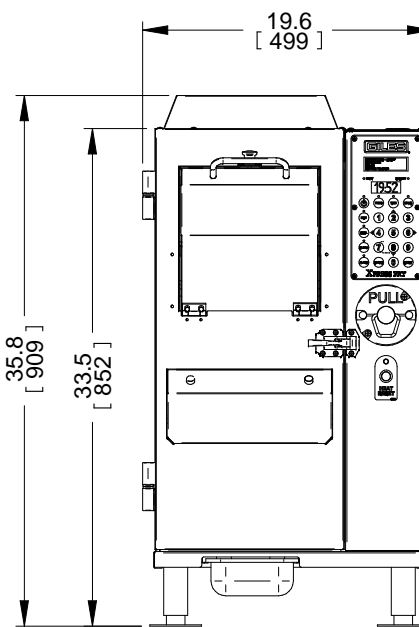

FRONT VIEW

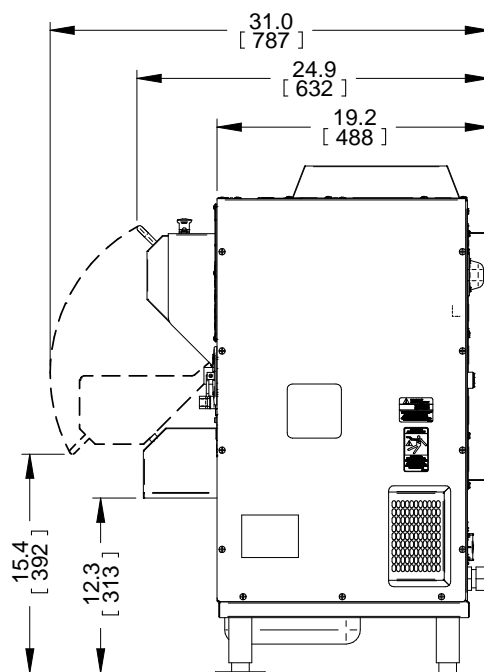

SIDE VIEW

## 1.3.2 Electrical Specifications

The GXF can be connected to either a **208/220 VAC** or **230/240 VAC** on a dedicated, grounded, circuit.

**NOTE:** The heating element in the unit is designed for operation on 240 VAC service ... connecting the appliance to a 208/220 VAC circuit will reduce the power output of the element and change cooking performance accordingly.

Model	Volts	Ph	Hz	kW	Amp	Breaker	6' Cord with NEMA Plug
GXF-F5	208	1	50-60	4.3	21.0	30A	NEMA 6-50 Plug
	240	1	50-60	5.7	24.0	30A	NEMA 6-50 Plug
GXF-F7	208	1	50-60	5.4	26.0	35A	NEMA 6-50 Plug
	240	1	50-60	7.2	30.0	40A	NEMA 6-50 Plug
GXF-F8	208	3	50-60	6.4	17.7	25A	NEMA 15-30 Plug
	240	3	50-60	8.5	20.5	30A	NEMA 15-30 Plug

## 1.3.3 Agency Certifications



## 1.3.4 Unit Weight

Model	Appliance Weight	Crated Weight w/ Accessories
GXF	190 lbs [86.2 kg]	251 lbs [113.9 kg]

## 1.3.5 Capacities

Model	Shortening		Cooking (French Fries) per hour		
GXF	21.0 lbs [9.5 kg]	3.0 gal [11.4 l]	3.0 lbs [1.4 kg] per load	20 loads	60.0 lbs [27.2 kg]

**NOTE:**

Stated cooking capacity is reference information for french fries only. Other food items (wings, tenders, fried vegetables, etc) will have differing results.



## 2. Installation

This section provides information and procedures necessary for safe and proper equipment installation. Please follow these steps to ensure a trouble-free installation and start-up, with minimum potential for malfunction, damage to property or equipment, or personal injury.

### 2.1 Appliance Location

1. Select a counter-top location that is sturdy, level, easily cleanable and fire resistant. Stainless steel, fire resistant laminate, or solid material surfaces such as granite are acceptable. **DO NOT** locate appliance on porous surfaces, as these are susceptible to bacterial growth.
2. This appliance is very heavy. Be certain that the structure on which it is to be located is sturdy enough to support the appliance, plus weight of oil and food product.
3. Ensure that there is adequate space for proper operation and servicing of the appliance. The Rear Panel of the appliance will need to be removed periodically for service and maintenance, and the sight window on the right-hand side must be accessible for periodic fire extinguisher inspections. 15" clearance is required at front of appliance for door opening and 12" to 14" space must be available on right side of unit for food pan placement.
4. The appliance must be operated in a space that has adequate ventilation.
5. The appliance must be located close enough to a power receptacle so that the power cord can be plugged in directly. **DO NOT use an extension cord.**
6. Depending on local building code, room size and/or other appliances in service, exhaust ventilation may be required for the space. This can often be accomplished by installation of a simple exhaust fan. To determine if such requirements must be met, consult with local code officials and/or HVAC professionals. Provide them the following information:
  - a. The appliance exhausts 60 to 80 CFM.
  - b. The average temperature of the exhaust air is approximately 90°F (32°C) after four (4) hours of continuous frying.
7. This appliance is to be installed, used and maintained in accordance with **NFPA 96, Standard for Ventilation Control and Fire Protection of Commercial Cooking Operations.**

Compliance with the above will help to ensure a safe and proper installation. If you have questions or need assistance, contact a local Giles Manufacturer's Representative or call **Giles Technical Services** at **800.554.4537**.

### 2.2 Electrical Preparation

1. A dedicated, grounded circuit suitable to supply power for the appliance load must be available, or be installed. It must comply with local codes and the **National Electrical Code (NEC)**.
2. An appropriate, permanently mounted, power receptacle shall be provided to accept the appliance's power cord plug ... see **Section 1.3.2**. **DO NOT** remove, or otherwise modify, the factory-installed power cord or plug. **DO NOT** attach the appliance to a power supply with an extension cord. Consult the unit's serial label for proper supply power requirement.
3. **Giles shall not be responsible for injuries or damage to equipment and/or property resulting from improper electrical installations.**

## 2.3 Unpacking

The appliance is typically shipped on a wooden pallet with a protective wooden framework, and secured with high-strength plastic strapping. The unit load is protected by machine applied stretch-wrap.

### **CAUTION**

- Assistance will be required to move and install this equipment. The appliance very heavy. Use sufficient manpower and exercise due care when lifting or moving the unit.
- Take care when removing stretch-wrap and wooden framework from around the unit.
- Failure to comply with these **CAUTION** notices may result in minor to moderate injury, damage to equipment or property, and void the warranty.

### **IMPORTANT!**

Inspect the appliance immediately upon receipt. The equipment was shipped from the factory in perfect condition and packaged in a way to minimize potential damage during transportation and handling. However, in the event the appliance was damaged during shipment, notify the freight company immediately and have the driver note all damages on the Bill of Lading.

1. Carefully cut and remove plastic wrap and strapping.
2. Using appropriate tools, remove the protective wooden framework from the shipping skid. Be careful to avoid personal injury, or damage to the unit.
3. Remove components that are packed inside the appliance cabinet:
  - Four (4) Adjustable Legs & Cap Nut
  - Heater Element Assembly
  - Under-cabinet Drip Pan
  - Oil Drain Hose
  - Cook Basket
  - Cook Pot
  - Additional Accessories purchased may also be packed inside
4. Carefully remove the appliance from the shipping pallet. Unit is very heavy. Use sufficient assistance and great care when lifting and moving the unit to avoid personal injury or equipment damage.



## 2.4 Adjustable Leg Installation

1. With appliance resting on a stable surface, have a helper tilt the unit forward and hold.
2. Install the back two (2) Legs (ones with mounting plate) on the cabinet, rotating clockwise until hand tight. **Take care not to cross-thread** ... leg should turn fairly easily until tight.
3. Have helper tilt unit backward onto the rear Legs and repeat the process for front two (2) Legs (ones without mounting plate).
4. After front Legs are installed, open the cabinet door and install the stainless Cap Nut on leg stud inside the front left-hand corner ... **This is a sanitation requirement.**

## 2.5 Electrical Requirements

### CAUTION

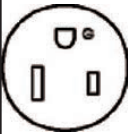
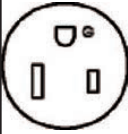
- This appliance must be powered by a dedicated, properly grounded circuit. Improper grounding may result in electrical shock. Refer to local electrical code and/or National Electrical Code (NEC) to ensure proper grounding of this, or any electrical equipment.
- Always consult a qualified, licensed electrician to ensure that circuit breakers and wiring are of sufficient rating and gauge to power the appliance load, and that a proper power receptacle is install.
- This appliance is available from the factory with any of the electrical specifications listed in the **Table 2.5**. below. Check the Serial Label to determine correct supply power required.

Model	Volts	Ph	Hz	kW	Amp	Breaker	6' Cord with NEMA Plug	
GXF-F5	208	1	50-60	4.3	21.0	30A		NEMA 6-50 Plug
	240	1	50-60	5.7	24.0	30A		
GXF-F7	208	1	50-60	5.4	26.0	35A		NEMA 6-50 Plug
	240	1	50-60	7.2	30.0	40A		
GXF-F8	208	3	50-60	6.4	17.7	25A		NEMA 15-30 Plug
	240	3	50-60	8.5	20.5	30A		

This appliance can be powered by either **208 VAC** or **240 VAC**.

**NOTE:** Heating element has optimum power output when connected to 240 VAC service. Connecting the appliance to a 208 VAC circuit will reduce the output of the element as shown above, which will change the cooking performance accordingly.

### 2.5.1 Electrical Service

1. Have a qualified, licensed electrician evaluate the available power in the location chosen for the appliance, compared to the information in **Table 2.5**.
2. If power supply is adequate, install the appropriate NEMA receptacle. The receptacle must be located within reach of the appliance's power cord. **DO NOT connect appliance using an extension cord.**
3. If the power supply is not adequate for the appliance, a new dedicated properly grounded circuit, sufficient to power the appliance load, must be installed in accordance with local electrical code, and/or the National Electrical Code (NEC), by a qualified, licensed electrician. **Giles assumes no responsibility for installation of proper electrical service.**

## 2.6 Appliance Placement

1. Place the appliance on a suitable countertop. Use adequate assistance when lifting and positioning the unit.
2. Adjust the Legs, as needed, to level the unit. Adjustment is accomplished by rotating the lower portion of the leg ... turning to the right shortens leg, turning to the left lengthens leg.
3. Two of the legs have surface mount plates. The appliance should be anchored to the countertop with appropriate screws to prevent tipping, or other unintended movement.
4. Obtain the Under-Cabinet Drip Pan (1/2 size x 2-1/2" deep) slide it into the holding brackets underneath Cabinet.

## 2.7 Initial Cleaning

### CAUTION

**DO NOT** cook with the appliance without first washing and sanitizing all components and surfaces within the food zone. Cleaning ensures removal of foreign material, dirt or debris that may have accumulated during transportation and any contamination which may remain from manufacturing processes.

Ensure that all of the protective film is removed from stainless steel surfaces prior to use.

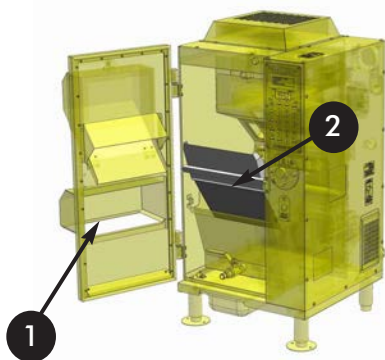

1. Open Cabinet Door ① and remove Cook Basket ②. The Basket rests in the motor drive couplings on left and right side of basket. Lift vertically to remove basket from couplings.

2. Remove the Cook Pot assembly ③ by grabbing the handle and sliding it towards you.

3. Separate Heating Element assembly ④ from Cook Pot ③ by lifting vertically.

4. Wash items 1 - 4 in warm soapy water followed by a hot water rinse. Thoroughly dry parts. **DO NOT submerge the upper Element Box, or spray with water.**

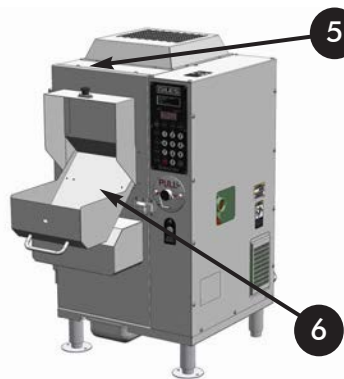
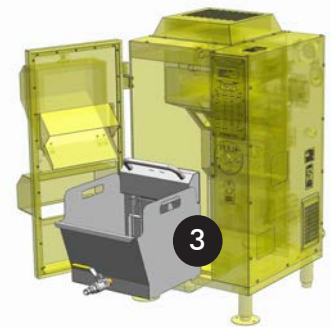

5. Close the Cabinet Door ①. Lift the Lock Pin ⑤ and carefully lower the Front Chute ⑥. Clean the chute interior with soap and water. Close the Front Chute ⑥ when finished.

6. With the Cook Pot assembly ③ and the Cook Basket ② still removed, open the Cabinet Door ① again and clean all interior and exterior surfaces with a sponge or cloth, using warm soapy water, rinse and wipe dry. A mild biodegradable degreasing cleaner, such as Simple Green®, may also be used.

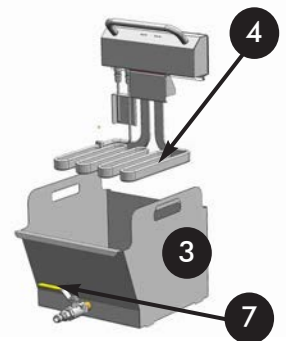

7. During the initial cleaning process, thoroughly inspect the appliance to ensure that all protective adhesive film has been removed from the stainless steel surfaces and all removable parts. Some of this film typically remains from the factory to provide extra protection for surface finish.

8. Before proceeding, return all items to their original position, ensure the Drain Valve ⑦ is in the closed position, and close the Cabinet Door ①

## 2.8 Wet Chemical Automatic Fire Extinguisher

The wet chemical automatic fire extinguisher in this appliance is charged with an extinguishing agent and is pressurized to the proper operating pressure. **It is NOT armed and ready to protect the unit against accidental fire.** Carefully read the **GXF Wet Chemical Automatic Extinguisher Manual** to become familiar with and understand operation and required maintenance.

**Prior to operating the appliance, the fire extinguisher must be checked for proper operation, certified and “armed” by a qualified and licensed fire protection equipment service company, having credentials acceptable to the authority having jurisdiction. The cost of this service is the responsibility of the User.**

**Procedures associated with this service are found in Section 3, Wet Chemical Automatic Extinguisher Manual, which is provided as a guide for trained service personnel.**

### **⚠ WARNING**

**Unit ships from the factory with fire extinguishing system in an the “UNARMED” condition. THE SYSTEM MUST BE ARMED BEFORE THE APPLIANCE CAN BE USED ... APPLIANCE WILL NOT OPERATE AND HEATING ELEMENT WILL NOT ENERGIZE UNTIL THIS IS DONE.**

**A Safety Ring Pin is in place to prevent inadvertent discharge during shipment and installation ... this Pin must be removed when system is armed. Retain the Pin for use during future servicing and inspections.**

With the exception of full discharge, the functionality of the system is fully tested at the factory prior to shipment, but it is impossible to predict whether unexpected disturbances during shipment might potentially impair proper operation. Failure to perform check-out and certification of the fire system could result in property damage, personal injury or damage to the appliance, and void the warranty should there be a malfunction during an actual event.

## 2.9 Air Cleaning Filters

1. The Grease Baffle Filter and the Charcoal Filter are factory-installed behind the Filter Cover (2), held in place by the Filter Cover Latch (1).
2. Refer to Section 4.3 for removal and maintenance.

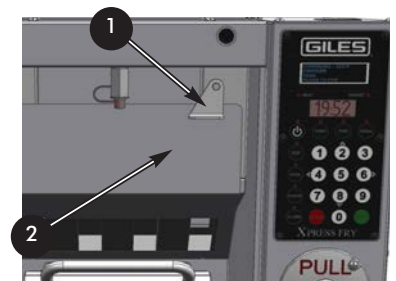

## 2.10 Service Connection

1. The appliance is equipped with a 6-foot Power Cord w/Plug. An appropriate matching Receptacle is required **(NOT PROVIDED)**. Refer to *Electrical Requirements, Table 2.5*.

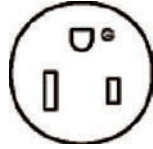

1-Phase Unit



3-Phase Unit

2. A dedicated, grounded circuit with properly sized circuit breaker and wiring is required to power the appliance. Always consult a qualified, licensed electrician to determine whether electrical requirements are met.
3. The power receptacle must be within reach of the appliance's power cord. **Never connect to an extension cord and do not change or otherwise modify the cord or plug.**

## 2.11 Clearance

1. The unit must setback from edge of counter approximately 14" (356 mm) to allow for placement of food pan used to collect cooked product when dumped. Clearance in front of unit must be maintained for normal operation, and allow space to periodically open the main cabinet door for service and maintenance.
2. A minimum overhead clearance of 8" (203 mm) should be maintained to allow unrestricted flow of exhaust air from the appliance air filtration system. Air flow restriction will reduce performance of the system. Do not place anything on top of the appliance that might obstruct the fan discharge outlet. **Obstructing the outlet can cause the unit to shutdown.**
3. Periodically, it is necessary to remove the right side panel to gain access to electrical and fire extinguisher system components for inspection and maintenance. Be sure to consider this fact when selecting a location and installing the unit.

## 2.12 Preparing the Vat

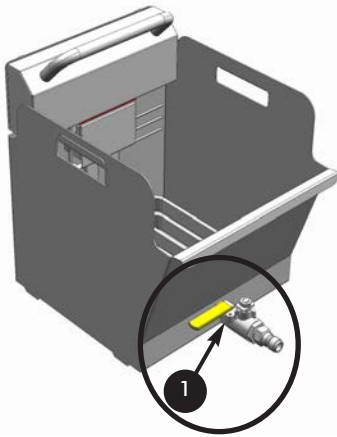

1. Refer to Section 2.7 for information on removing, cleaning, and reinstalling the Cook Pot assembly. Once the Cook Pot and Cook Basket are in place, confirm the Drain Valve ① is **[CLOSED]**.
2. Fill Cook Pot with commercial grade frying shortening. Cool oil should be filled to the **ADD** line only ... expansion will occur when heated; oil level can be topped-off to the **FULL** mark, if needed. **DO NOT OVERFILL..**
3. Close and latch the Cabinet Door. Press and place a stainless steel food pan (not provided) under the food discharge hood..

READY TO COOK!

### CAUTION

- Over-filling Pot will result in excessive oil splash and splatter.
- Under-filling can result in poor cooking performance and/or erratic temperature control.
- Very low oil level can cause excessive smoking.

### ⚠ WARNING

**NEVER OPERATE WITH VERY LOW OR NO OIL. TURNING THE APPLIANCE ON WHEN THE HEATING ELEMENT IS NOT COMPLETELY COVERED, OR ONLY MINIMALLY COVERED, CAN POSE A SIGNIFICANT RISK OF FIRE.**

## 2.13 Initial Power-up

### **⚠ WARNING**

**NEVER** turn ON the appliance when the heating element is not completely covered, or only minimally covered with cooking oil. Doing so can pose a significant risk of fire, or serious damage to the unit.

1. Verify that all electrical specifications have been met as described in **Section 2.5, Electrical Requirements** and that the appropriate power receptacle is installed and powered.
2. Plug the **Appliance Power Cord** ① into power receptacle. **DO NOT** use extension cord.
3. Using the **Appliance Power Switch** ② on the back of the unit, turn **ON** the fryer.
4. Controller proceeds through a power up sequence. At the conclusion, an alarm sounds and the message **"POWER FAILURE, PRESS [START] TO PREHEAT"** is shown on the upper **OLED Display** and **"HOLD"** is shown on the **7-Segment Display**.
5. Press the **[ALARM]** key to silence alarm.
6. This sequence confirms that unit is properly powered and should be ready for cooking operations. At this point **DO NOT** press **[START]** as prompted by the Controller, only proceed to **Step #6**.
7. Press the **[POWER]** button .... **OLED Display** momentarily reads **"PLEASE WAIT"**, then Controller shuts down and enters **SLEEP** mode. The red LED above the power button flashes to indicate that appliance is in **SLEEP** mode.

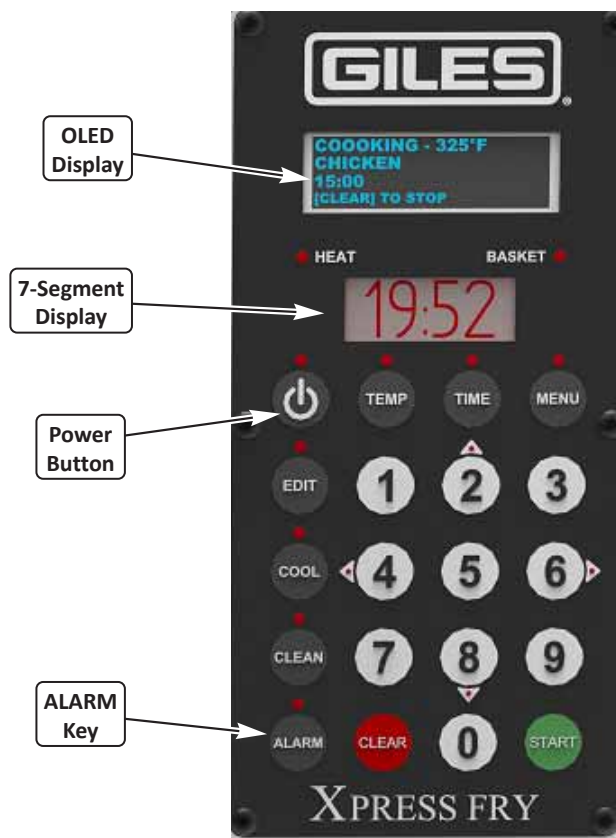

## 3. Operation

The following sections explain operations and procedures of the **Giles XPressFry, GXF Ventless Countertop Electric Fryer**.

### **DANGER**

- Turn off the appliance and unplug the appliance's power cord before cleaning or performing maintenance.
- **DO NOT** hose down the appliance's interior or exterior with water from any type of spray hose.
- Failure to comply with this **DANGER** notice will result in serious injury, even death, damage to equipment or property, and void the warranty.

### **CAUTION**

- Ensure that the appliance has been positioned in a secure and safe location. It is strongly advised to anchor the unit to the countertop, utilizing the leg mounting plates.
- Ensure that electrical installation complies with the specifications of the appliance and that the unit is properly grounded before placing into service.
- Due to the high temperature of cooking oil in the fryer during operation, it is extremely important that the user exercise due caution when working with and around the appliance to avoid personal injury.
- This appliance is not intended for use by persons (including children) with reduced physical, sensory, or mental capabilities, or lack of experience and knowledge, unless they have received adequate instruction and/or supervision concerning its use, by a person responsible for their safety. **Children should be supervised, or otherwise restricted, to ensure they do not play with or around this appliance.**

## 3.1 Appliance Overview

The following sections provide a general overview of the **GXF Countertop Electric Fryer** and its accessories. Please take time to review this information to become familiar with the appliance and some of the features.

## 3.1.1 Appliance Exterior



\* Hidden  
+ Not included

## 3.1.1 Appliance Exterior - continued

Item	Description	Function
1	Main Cabinet Door	Provides access to the Cook Pot, Cook Basket, Heating Element Assembly, and Filters. Door must remain closed during normal operation
2	Food Loading & Delivery Chute Assembly	Lift knob on top of chute to unlock. Grab chute handle and lower it slowly until it rests on the bumpers below. Place frozen food product into chute. Raise chute until lock pin automatically engages and food will slide into cook pot. At end of cooking time, cook basket automatically raises, and dumps cooked product into waiting food pan.
3	Fire System Manual Activation Pull	Pull ring to instantly activate the wet chemical fire extinguishing system. Normally, in the event of accidental fire, the automatic detection system activates the fire extinguisher ... the manual pull is a second safety method of activation.
4	Fire Extinguisher Inspection Window	Provides view of the fire extinguisher pressure gauge. System must be inspected monthly. Heating element will be disabled if pressure is excessively <b>LOW</b> .
5	<b>XPressFry</b> Controller	Microprocessor cooking controller ... sets & controls cooking temperatures and times; controls the basket lift. Stores up to (50) menu item cooking presets. Accurately monitors operation, displays alarm/status information & user prompts; features COOL, AUTO-COOL & CLEAN mode. Multiple language and password protection options.
6	Power Cord & Plug	Six (6') foot appliance power cord with molded plug.
7*	Stainless Steel Food Pan <b>(NOT INCLUDED)</b>	Catches and holds cooked product when discharged from the unit.
8	Exhaust Discharge Outlet	Discharge outlet for exhaust air, which has been cleaned by the filter system. Air is recirculated back into the room ... no venting to the outside is required. <b>THIS OUTLET CANNOT BE OBSTRUCTED.</b>
9	Door Latch	Latches and holds Door securely closed. The appliance will not operate unless Cabinet Door is securely closed.
10	High-Limit Reset	If the heating element is shutdown due to an overheat condition, pressing this button resets the high limit safety control after temperature has cooled. <b>DISCONTINUE COOKING UNTIL CAUSE FOR ANY HIGH LIMIT CONDITION IS DETERMINED AND CORRECTED.</b>
11	Under-cabinet Drip Pan	Catches any oil residue generated inside cabinet.
12+	Power Switch	Turns unit <b>ON/OFF</b> .
13	Food Discharge Hood	Dispenses food into food pan (not included) below. (Part of Item 1 - Main Cabinet Door)

\* Hidden

+ Not included

## 3.1.2 Cabinet, Cook Chamber







\* Hidden

## 3.1.2 Cabinet, Cook Chamber - continued

Item	Description	Function
1	Cook Pot	Contains the cooking oil for frying. Removable for cleaning.
2	Cook Basket	Contains food product during the cooking cycle. Features non-stick coating for easy clean-up. Automatically dumps cooked product to waiting Food Pan at end of cycle.
3	Stainless Steel Baffle Filter	First stage of the ventless air filtering system. Captures large grease particulate generated during cooking. <b>The Baffle Filter must be cleaned daily. Heating element is disabled if not properly installed.</b>
4	Charcoal Fiber Filter	Second stage of the ventless air filtering system. Captures fine grease particulate, and activated charcoal fiber helps to neutralize aromas to freshen the recirculated air. The Charcoal Filter is replaced as needed, generally every 60 to 90 days. <b>Heating element is disabled if not properly installed.</b>
5*	Fire Extinguisher System Detector Link	Detector link melts in the event of accidental fire automatically activating the wet chemical fire extinguishing system.
6	Fire Extinguisher discharge Nozzle	Nozzles located over the Pot and inside the Filter Chamber. Sprays wet chemical fire extinguishing agent when system is activated.
7*	Filter Access Cover	Remove to provide access to the Filter Chamber. <b>Heating element is disabled if not properly installed.</b>
8	Heating Element Assembly	Complete heating element assembly plugs into receptacle on back wall. Removable for easy cleaning. The assembly contains the oil temperature and high-temperature shutdown (high-limit) sensor.
9	Cook Pot Drain	Provides a convenient means to drain used cooking oil from the Cook Pot. 43" Drain Hose is provided.

\* Hidden

## 3.1.3 Accessories Included

Part	Description/ Part Number	Function
	<p>Under-cabinet Drip Pan P/N 71683</p>	<p>Catches any oil residue generated inside cabinet.</p>
	<p>Cook Basket P/N 94514</p>	<p>Contains food product during the cooking cycle. Features non-stick coating for easy clean-up. At end of cycle, automatically dumps cooked product to waiting food pan.</p>
	<p>Stainless Steel Baffle Filter P/N 41212</p>	<p>First stage of the ventless air filtering system. Captures large grease particulate generated during cooking. <b>Must be cleaned daily.</b></p>
	<p>Charcoal Fiber Filter P/N 41389</p>	<p>Second stage of the ventless air filtering system. Captures fine grease particulate, and activated charcoal fiber helps neutralize aromas to freshen the recirculated air. <b>Replace as needed, generally every 60 to 90 days.</b></p>
	<p>43" Oil Drain Hose w/ Quick Connect P/N 80851</p>	<p>Use to connect to Cook Pot Drain Valve for removing waste oil from pot.</p>

## 3.1.4 Accessories Not Included

Part	Description/ Part Number	Function
	Side Chute P/N 80176	Used to switch from front delivery of cooked product to left or right side delivery.

## 3.2 Controller Overview

The following section explains the functions, features and operation of the XPressFry Cooking Controller.

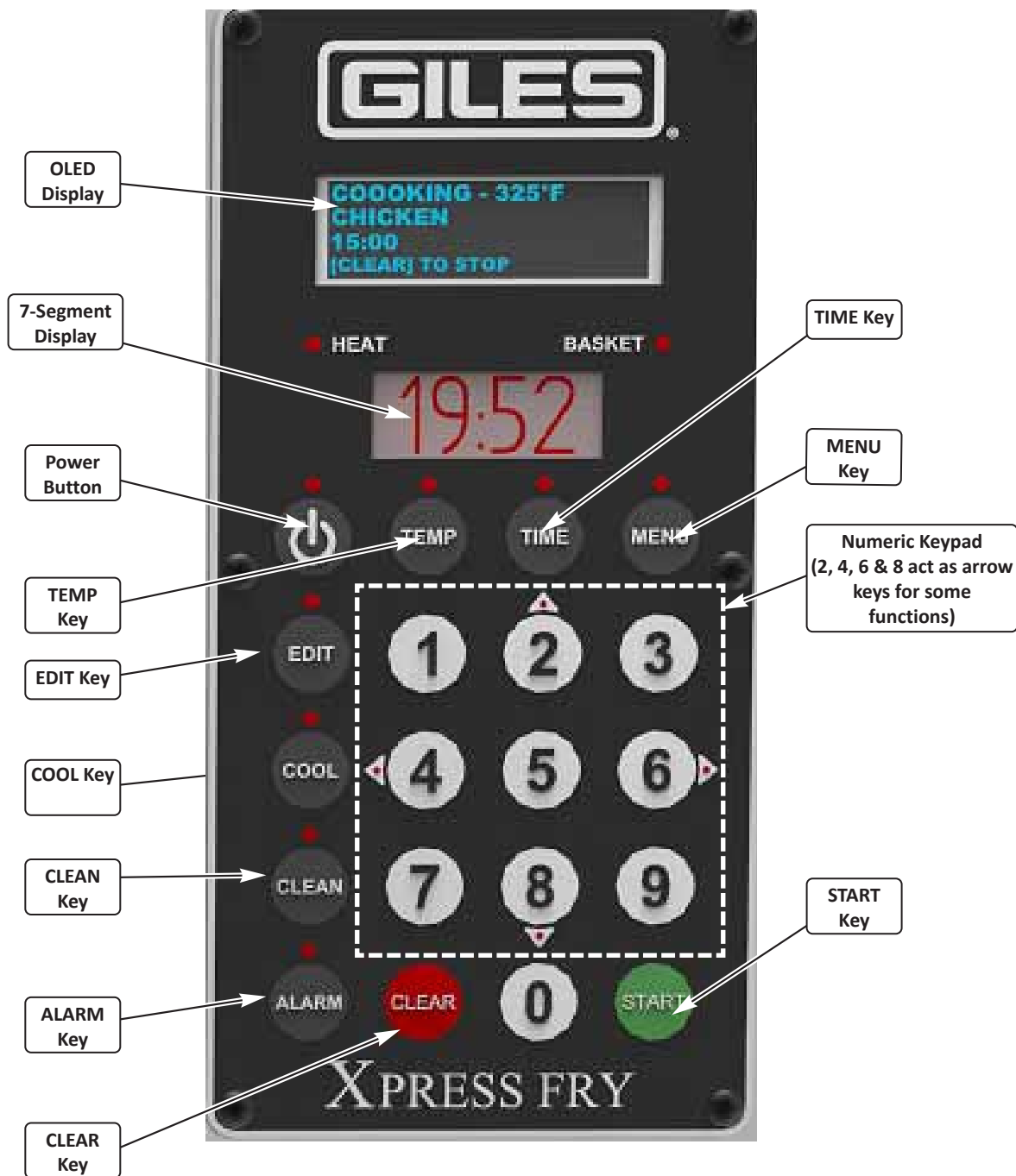

## 3.2 Controller Overview - continued

<b>OLED Display</b>	Displays cook settings (cycle time & temp set-point), menu preset settings, and various status messages, alarms and/or operational prompts..
<b>7-Segment Display</b>	Displays temp, cook cycle countdown, controller error codes, various status messages, etc.
<b>Power Button</b>	Press to place appliance into <b>SLEEP</b> mode. When in <b>SLEEP</b> mode, press to power-up unit to begin cooking operations. Red indicator above the button will flash while in <b>SLEEP</b> mode,
<b>TEMP Key</b>	Press this key to set the cooking oil temperature setpoint. Pressing this key twice (2X) will display <b>actual oil temperature</b> on the <b>Lower Display</b> for approximately 20 seconds.
<b>TIME Key</b>	Press this key to begin manually setting a cooking time (mm:ss).
<b>MENU Key</b>	Action key which is pressed in combination with other keys to access programmed menu presets. Fifty (50) different Menu Item cooking presets can be programmed.
<b>EDIT Key</b>	This is an action key which is pressed in combination with other keys to enter edit mode for changing or creating Menu preset settings.
<b>COOL Key</b>	Press to enter <b>COOL</b> mode. Energy-saving feature for inactive periods; Fryer will idle at a lower temperature. Temperature setpoint changes to the [ <b>COOL TEMP</b> ] specified in <b>USER SETTINGS (see Section 5.1.7, Access &amp; Edit User Settings)</b> . <b>Default setting = 275°F.</b>
<b>CLEAN Key</b>	Press to enter <b>CLEAN</b> mode. Raises basket to a position were it is easily removed, allowing for removal of pot/heat element assembly for cleaning purposes.
<b>ALARM Key</b>	Press to silence an alarm tone. Silences alarm only, does not clear error/alarm conditions.
<b>Numeric Keypad</b>	Use to input time and temperature values to the Controller, select Menu Presets for cooking and to create or edit Menu Preset names and settings. Keys [ <b>2 - 4 - 6 - 8</b> ] serve as “arrow keys” for navigating through lists and other various Controller prompts.
<b>CLEAR Button</b>	Function key used to cancel cook cycles, exit certain Controller functions, etc. Also serves as a <b>backspace</b> key for correcting mistakes when entering values.
<b>START Button</b>	Press to start cooking cycles, input values, respond to certain Controller prompts or save an entered setting.

## 3.3 Start-up/General Operation

- 1A. If unit is **NOT** plugged in and/or circuit breaker for the outlet power is **OFF**, turn **ON** power supply and/or plug power cord into receptacle. See *Section 2.13, Initial Power-up*.

The Controller initializes then sounds an alarm and the Upper Display shows the message **"POWER FAILURE - PRESS [START] TO PREHEAT"**. Press **[ALARM]** key ① to silence alarm. Press **[START]** key ② ...

... OR ...

- 1B. If unit is in **SLEEP** mode (controller displays blank & red indicator above **[POWER]** button ③ flashing), press **[POWER]** button.
2. Alarm sounds and message **"OPEN DOOR, CHECK OIL LEVEL"** is displayed ... press **[ALARM]** key ① to silence alarm.
3. Unlock and open the main Cabinet Door. Alarm sounds again and **"DOOR OPEN"** is displayed ... press **[ALARM]** ① to silence. Confirm that the oil level in pot is between **[FULL]** and **[ADD]** level marks.

### **WARNING**

**IMPORTANT! DO NOT** proceed if cook pot **DOES NOT** contain proper quantity of cooking oil. Doing so can damage the unit and possibly present a fire risk. Add oil as needed, see *Section 2.12*.

4. Close and securely lock the Door. Alarm sounds again and the message **"PRESS [START] TO RESUME"** is displayed. Press **[START]** ②; alarm is silenced and if actual oil temp is less than setpoint temp, unit enters **PREHEAT** mode and oil begins heating.
- If actual oil temp is at or above setpoint temp, unit does not enter **PREHEAT** mode.
5. When oil temperature reaches setpoint, user is notified by an alarm and the displayed message **"SETPOINT REACHED"**. After user acknowledges alarm by pressing the **[ALARM]** key, the unit enters **READY** state ... ready for cooking.



#### **NOTE:**

While in **PREHEAT** mode, real-time actual oil temperature is displayed on the **7-Segment Display**. Once setpoint is reached, the display changes to show **setpoint temperature** (either manual input or selected preset).

## 3.3 Start-up/General Operation - continued

6. While in **PREHEAT** or **READY** state, user can select a different Menu Item Preset (see *Section 3.4.2, Selecting a Menu Preset*) which will automatically change cooking temperature and time to the new setting. If selected preset temperature is higher than the current setpoint, unit will re-enter **PREHEAT** mode for heating to the new setpoint.

-- OR --

User can manually set a cooking time and/or cook temperature, see *Section 3.4., Setting a Manual Temperature & Cook Time*.

**NOTE:** If the **PASSCODE ENABLE** setting is [ON], then user cannot set a “manual” time or temperature without entering a password. This lockout feature helps ensure consistent cooking procedures for those users who operate multiple locations.

### 7. START:

Information for a selected Menu Preset, or a “manual” time and temperature, is shown on the **Upper OLED Display**. Setpoint (preset or manual) is displayed on the **Lower 7-Segment Display**.

To start the cooking cycle, press the [START] key.



## 3.4 Working with Menu Item Presets

Fifty (50) **Menu Item** preset cook settings are stored in the Controller, each includes:

- **Menu No.** - Sequential ID number
- **Menu Name** - Name of the food item assigned to the preset.
- **Cooking Time** - Cook time setting for the specific food item ... time automatically changes to this setting when the menu item is selected to cook.
- **Cooking Temperature** - Cooking oil temperature setting for the specific food item ... setpoint automatically changes to this setting when the menu item is selected to cook.

All 50 presets are factory-programmed with default settings shown in the table on the right. Ten (10) have been set to some typical specific menu items. The others contain the general settings shown on the last line. Users can edit any of the settings as needed to customize for specific applications and menu offerings.

Details for working with Menu Item presets are covered in the following sections.

MENU NO.	MENU NAME	TEMP (F°)	TIME (MM:SS)
1	BONE-IN-CHICKEN	335°	13:00
2	TENDERS	335°	7:00
3	WEDGES	335°	6:00
4	BONE-IN-WINGS	335°	8:00
5	BONELESS WINGS	335°	7:00
6	POPCORN CHICKEN	335°	3:00
7	LIVERS	335°	4:00
8	CORNDOGS	335°	10:00
9	CHEESE STICKS	335°	3:00
10	FISH	335°	3:00
<b>11 - 50</b>	<b>MENU XX</b>	<b>335°</b>	<b>2:00</b>

## 3.4.1 Editing a Menu Preset



Press the [MENU] key twice (2X)

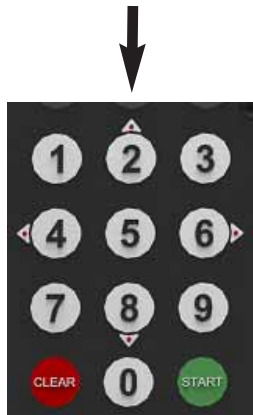

Use numeric keypad [2] - [8] (up/down) to scroll through list to the desired Menu No.



**DO NOT** press [START]

Press the [EDIT] key to select & display current Menu values on the Upper Display



Use numeric keypad [2] & [8] (up/down) to move pointer [←→] to select which item to edit:

**NAME**  
**TIME**  
**TEMP**



Press [START] key to begin edit of selected item.

**Editing [NAME] - Method 1:**  
Enter NAME letter by letter.



Scroll to [NAME] as explained on left. Use numeric keypad [2] & [8] (up/down) to scroll through letters. Character at cursor position changes. Stop when desired character appears, then use [4] & [6] (left/right) to move cursor to next character, repeat until name is spelled.



When finished editing, press the [START] key.

Pressing [CLEAR] exits without Saving



**Editing [NAME] - Method 2:**

Select a NAME from Catalog of programmed names.



Scroll to [NAME] as explained on left. Press [0] to open catalog. Use numeric keypad [2] & [8] (up/down) to scroll through the list. Press [START] key to copy a NAME and return to previous display.



Press the [START] key to Save the NAME.

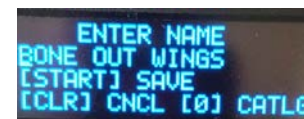

Pressing [CLEAR] exits without Saving

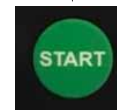

## 3.4.1 Editing a Menu Preset - continued

C. **Edit COOKING TIME:** Scroll to and select [TIME] as explained on Page 26.



Use numeric keypad to enter **TIME** (mm:ss)

After entering new **TIME** value press the [START] key to Save.

Pressing [CLEAR] exits without Saving



D. **Edit SETPOINT TEMPERATURE:** Scroll to and select [TEMP] as shown on Page 26.



Use numeric keypad to enter **TEMP** (°F)

**NOTE:** TEMP unit can be changed to (°C) in USER SETTINGS, see Section 3.4.8.

After entering new **TEMP** value press the [START] key to Save.

Pressing [CLEAR] exits without Saving



When finished editing:

- To select this Menu for cooking, press [EDIT] or [CLEAR] key, then press [START].
- To return to the previous active Menu Item preset, press [CLEAR] key twice (2X).
- To edit another Menu Item, either scroll to the Menu No. by using the [4] or [6] key —OR— press the [CLEAR] key once, then scroll to Menu using the [2] or [8] keys and press [EDIT] again.

## 3.4.2 Selecting a Menu Preset for Cooking

### **⚠ WARNING**

Even though the appliance is equipped with High Temp Safety interlocks and an automatic fire extinguishing system, **DO NOT** operate the unit unless oil level is at or above the {ADD} mark on Pot wall. Should the element energize when not completely covered with oil (or only barely covered), there is a significant risk of fire.

Before entering/changing temp settings or selecting menu item presets, **ALWAYS BE SURE THAT THE POT CONTAINS THE PROPER AMOUNT OF COOKING OIL.** Generally, the Controller goes directly into PREHEAT mode and energizes the element as soon as temp entries or selections are made.

**A. Direct Entry Method** - Desired Menu No. is known.

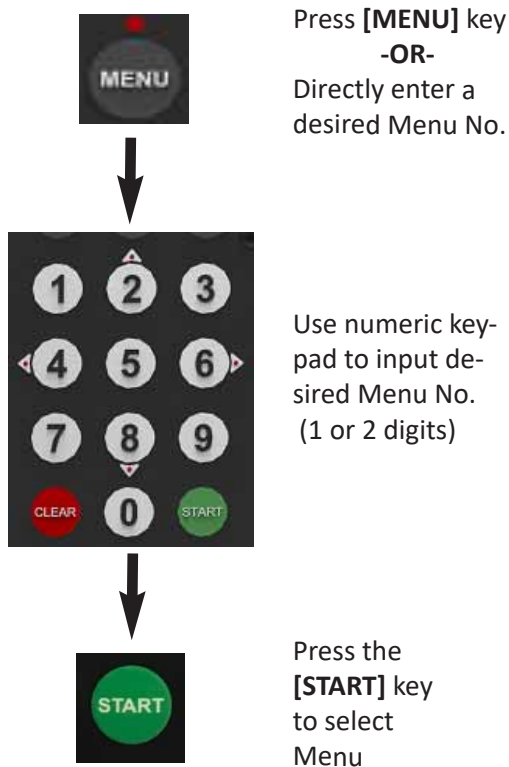

**B. Scroll Method** - Scroll through list of Menu Presets. Menu No., Name, Cook Time & Cook Temp are shown on the **Upper OLED Display**.

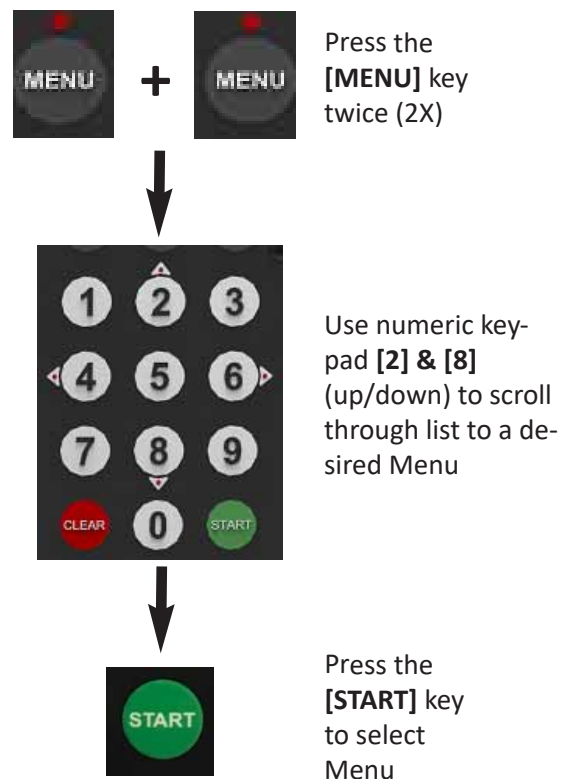

After selecting a preset, Menu Item settings are displayed on the Upper OLED Display.

If actual oil temperature is less than the temperature setpoint of the Menu selected the Controller enters **PREHEAT** mode and oil begins heating. If the actual oil temperature is already higher than setpoint, an alarm sounds and the message **"SETPOINT REACHED"** is displayed. Controller enters **READY** state after the [ALARM] key is pressed to acknowledge the alarm.

## 3.5 Setting a Manual Cooking Time and Temperature

As an alternative to choosing a Menu Item preset, User can also manually input a temperature and time for cooking an item, within the allowed ranges of the Controller software. This section describes the procedure.

**NOTE:** Manually inputting a cook **Time/Temperature** rather than selecting a preset causes the active menu name in the **Upper Display** to show as “**MANUAL**” instead of a showing specific menu Item name.



### IMPORTANT!

If the **PASSCODE** feature is {**ON**}, Time and Temperature settings **cannot** be input manually without a required password. Users are restricted to choosing from the list of available programmed Menu Item presets, see **Section 3.4.2, Selecting a Menu Preset for Cooking.**

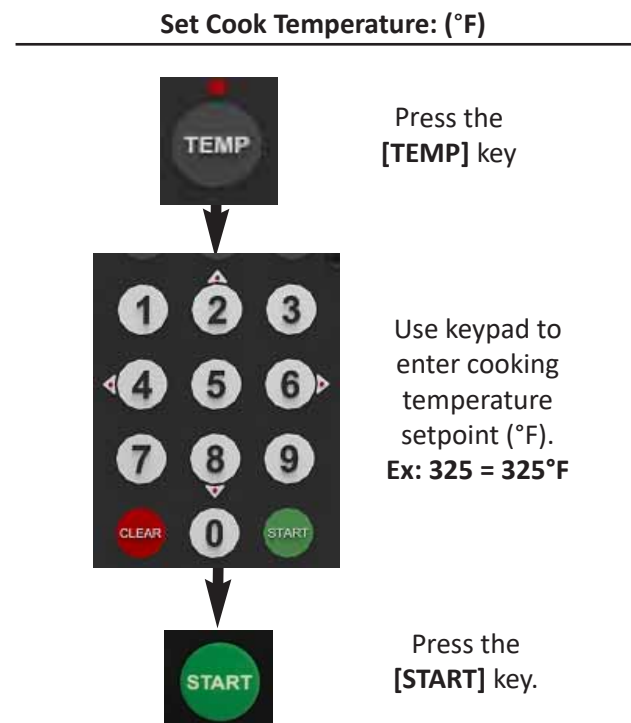
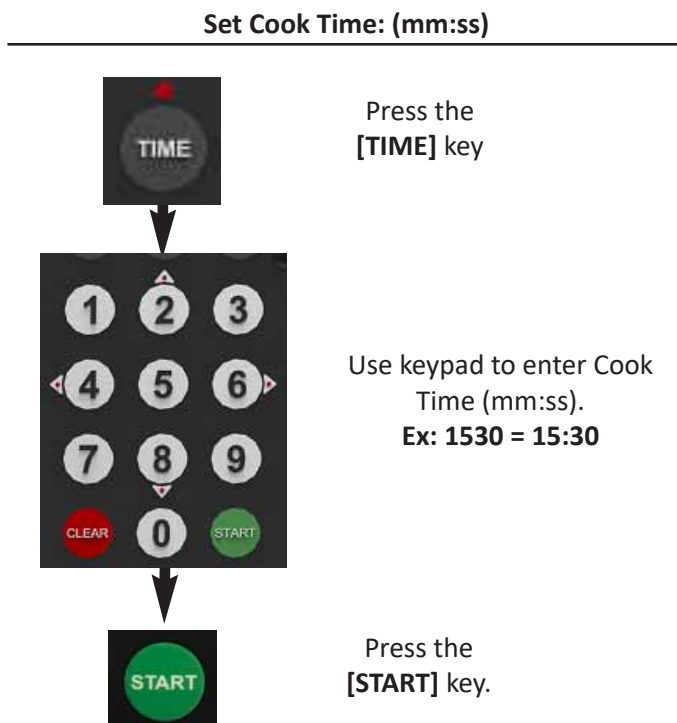

**NOTE:**  
Pressing the [TEMP] key twice (2X) will display the actual oil temperature for 20 seconds

- After a temperature is entered, if actual oil temp is less than the entered setpoint and if Door is closed and locked, the Controller enters **PREHEAT** mode; red [HEAT] indicator turns **ON** ... oil begins heating.
- If oil temperature is already equal to or higher than the entered setpoint, an alarm sounds and the message “**SET-POINT REACHED**” is displayed. Press the [ALARM] key to acknowledge alarm and place the Controller into **READY** state.

**Fryer is ready for cooking.**

While in **PREHEAT**, the real-time actual oil temperature will show on the **Lower 7-Segment Display**. After setpoint is reached, the display changes to show the **temperature setpoint**.

## 3.6 Other Controller Features

### 3.6.1 COOL Mode

**COOL Mode** is an energy-saving feature that changes oil temperature setpoint to a lower value. Used to put Fryer into an standby state (**COOL TEMP**) during downtime periods.



To enter **COOL MODE**, press the **[COOL]** key. The temperature setpoint changes to the **COOL TEMP** specified in **User Settings**, see **Section 3.7, Edit User Settings**. **Factory-default is 275°F**. Allowable value range for this setting is **200°F to 350°F**.

To exit **COOL Mode** press the **[CLEAR]** key twice (**2X**)



X 2

Press **[4]** key to continue in **COOL Mode**.



Upon exit, the temperature setpoint will return to the previous active value and Fryer will enter **PREHEAT** mode until temperature is reached.

### 3.6.2 AUTOCOOL Feature

When the **AUTOCOOL** feature is turned **[ON]** in **User Settings**, the Fryer automatically enters **COOL Mode** after no cook cycles are started within the amount of time specified by the **AUTOCOOL TIME** setting, see **Section 3.2.1, Edit User Settings**.

**Factory-Default Setting is [OFF] and AUTOCOOL TIME = 30 mins.** Allowable value range is **1 to 510 mins.**

To exit **COOL Mode** press the **[CLEAR]** key twice (**2X**)

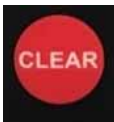

X 2

Press **[4]** key to continue in **COOL Mode**.



Upon exit, the temperature setpoint will return to the previous active value and Fryer will enter **PREHEAT** mode until temperature is reached.

### 3.6.3 CLEAN Mode

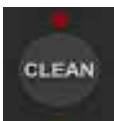

Pressing the **[CLEAN]** key before opening the Door raises the Basket out of oil and stops it in a position that allows for easy removal for cleaning. Basket must be first be removed before the pot/element assembly can be removed for oil disposal and cleaning.

After cleaning activities have been completed, Basket has been replaced and Door closed, pressing **[CLEAN]** key again followed by pressing **[START]**, returns Basket to the "home" position.

## 3.6.4 PASSWORD Protection

It is possible to enable **PASSWORD** protection for certain Controller functions/settings. This feature is typically factory-set as **[OFF]**. When **PASSCODE ENABLE** is **[ON]** in **Factory Settings**, user is prompted for a password before certain functions or actions can be performed.

If you desire to have Password protection enabled, or have questions concerning this feature, call **Giles Technical Services at 800.554.4537** to request the passcode and instructions as to how to enable this feature.

## 3.7 User Settings - Access and Edit

Follow steps below to access and edit User Settings.

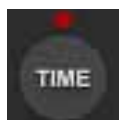

Press the  
[TIME] key

+ 9999 +

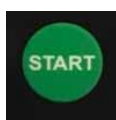

Press  
[START] key

### NOTE:

If Controller displays prompts **"ENTER PASSCODE"** when [TIME] key is pressed, call **GILES Technical Support** at **800.554.4537, or 334.272.1457**, for passcode.

Use numeric keypad [4] - [6] (left/right) to scroll through list until desired Setting is shown on the **Upper OLED Display**.

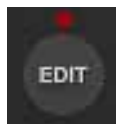

To edit setting press the [EDIT] key. Use numeric keypad [2] - [8] (up/down) to change the value. Press [EDIT] again to save the new value.

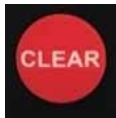

To exit the **User Settings** menu, press the [CLEAR] key.

### NOTE:

The message **"TOO LOW"** or **"TOO HIGH"** will be displayed if a value being entered is outside the allowable range and would cause a Controller error for the current state of the Fryer.

## 3.7 User Settings - Access and Edit - continued

Following table shows the User Settings allowable value ranges and the factory-set defaults in the Controller:

NAME	DESCRIPTION	RANGE	DEFAULT
TEMP SCALE	Temperature scale.	°F or °C	°F
GUARD BAND	Cooking not allowed if oil temperature deviates from the set-point by the amount of guard band setting.	1 to 990	900
MAX SETPOINT	Maximum oil setpoint allowed.	32°F to 350°F	350°
AUTOCOOL	After a specified amount of time, unit will go into <b>COOL</b> mode.	ON - OFF	OFF
AUTOCOOL TIME (Minutes)	If <b>AUTOCOOL</b> is <b>ON</b> , then after fryer is idle for the amount of time specified by this setting, the unit will enter <b>COOL</b> mode.	1 to 510 minutes	30
AUDIBLE ALARM (Seconds)	Audible alarm silences automatically after this many seconds.	5 to 120 seconds	10
COOL TEMP	Temperature setpoint for <b>COOL</b> mode	200°F to 350°F	275°F
SLEEP MINIMUM TEMPERATURE	After pressing <b>[POWER]</b> button, the temperature to which the oil must cool before unit will shutdown and enter <b>SLEEP</b> mode (fan stops and Controller displays turn <b>OFF</b> ) .	90 - 205°F	200°F
LANGUAGE	Sets the Controller language	English, Spanish, French	English
BASKET RISE TIME	Number of seconds the basket lift motor runs, raising the Basket after <b>[CLEAN]</b> key is pressed; determines basket position for removal. Also at the end of a cook cycle, sets position for Basket to stop for draining.	0.0 - 2.5 secs.	1.5 secs.
BASKET HOLD TIME	Amount of time (secs) Basket holds and drains after BASKET RISE TIME completes.	0.2 - 10.0 secs.	4.0 secs.
BASKET LOWER TIME	Amount of time (secs) lift motor runs to lower Basket after it has raised fully UP before changing direction to raise again for shaking action.	0.0 - 2.0 secs.	1.0 sec.
FORCE OIL CHECK	After this number of cook cycles, an alarm sounds and user is prompted to <b>"OPEN DOOR, CHECK OIL LEVEL"</b> .	8	8 cycles

## 3.8 Controller Errors and Alarms

When certain conditions occur that can result in unsafe operation or damage to the unit (electrical malfunction, mechanical failure, fire system problem, etc.), Fryer operation is disabled, an alarm is activated, and a two-digit Error Code [Er XX] is displayed. Error code is shown on the **Lower 7-Segment Display**; error description is shown on the **Upper OLED Display**. Typically, the Fryer remains disabled until error condition is corrected. Pressing the **[ALARM]** key silences the alarm tone, but does not clear the error. Error Codes are shown on the following Table.



ERROR CODE	DESCRIPTION (OLED Display)	PROBLEM
13	OIL PROBE Error	Problem with the Variable Oil Temp Probe. <b>Service technician required.</b>
23	FILTER CLOGGED	Pressure switch not engaging. Indicates airflow restriction; Charcoal Filter is clogged, or other obstructions. Replace Filter, remove obstructions
37	EEPROM ERROR	Error occurred while saving a setting to the Controller EEPROM. Call <i>Giles Technical Service</i> .
38	INTERNAL ADC ERROR	The ADC chip that reads temp probes has stopped working. Unplug unit and restart to attempt to clear error. Call <i>Giles Technical Service</i> if problem persists.
40	DOOR IS OPEN	When door is open, 7-Segment will display <b>“door”</b> .
41	OPEN DOOR, CHECK OIL	User prompt ... door must be opened to check oil level and re-close before continuing. Prompt is to ensure that pot contains proper quantity of oil. 7-Segment displays <b>“OPEn”</b>
42	CHECK, BAFFLE, CHARCOAL, AND FILTER COVER	Either the Filter Cover is not installed, or Baffle Filter or Charcoal Filter is missing, not properly installed.
43	ELEMENT BOX MISSING	The Element Assembly is missing or not properly connected (e.g. after cleaning).
44	BASKET JAM	Controller has sensed that the Basket is jammed or in a bind. Limit switches have not been engaged in the correct amount of time.
47	FIRE SYSTEM PRESSURE	Fire system pressure has fallen below allowable limit, or system has been discharged. Unit is disabled. Contact authorized fire protection service company.
48	FIRE SYSTEM LEVER	Fire system is not cocked and armed. Contact authorized fire protection service company.

## 3.8 Controller Errors and Alarms - continued

ERROR CODE	DESCRIPTION (OLED Display)	PROBLEM
49	PRESS [START] TO RESUME	Displayed when door is closed after an <b>OPEN DOOR</b> event. Heat remains <b>OFF</b> until user presses <b>[START]</b> key. 7-Segment displays <b>“Hold”</b> .
50	ELEMENT BOX NOT ENGAGED	The element box assembly is not fully engaged (plugged in). Controller senses the probe but not the element box switch. Push box in further to completely engage.

### 3.8.1 Resolving Controller Errors and Alarms

- FILTER CLOGGED [Er 23]:** Alarm tone sounds, **Lower Display** shows **“Er23”**, and the **Upper Display** reads **“ERROR ALARM - CLOGGED FILTER”**. Indicates that airflow through the Fryer air filter system has fallen below the acceptable limit for proper performance. Generally, this error means that the Charcoal Filter is clogged and must be replaced. However other airflow restricting conditions will also cause it, such as blockage of exhaust outlet on top of unit or a blockage inside the cabinet. Heating Elements are turned **OFF** until condition is corrected. **a).** Replace Charcoal Filter with new filter, **b).** check for other restriction inside cabinet, **c).** ensure exhaust outlet is clear (8” above required). Error will clear when proper airflow is restored.
- OPEN DOOR, CHECK OIL [Er 41]:** Alarm tone sounds, **Lower Display** shows **“OPEn”**, **Upper Display** reads **“OPEN DOOR, CHECK OIL LEVEL”**. Error is a designed safeguard to avoid operating the Fryer with too little or no oil in the pot. Operating with low (or no) oil can result in equipment damage, poor cooking performance, excessive smoking, or fire. Error occurs at every start-up after the unit has been **OFF**, or in **SLEEP** mode. The Controller also gives the alarm after a set number of cook cycles have been completed. Open door check oil level (add if needed), then close and latch door.

**Error 49** will occur after door has been closed.
- FILTER COVER, BAFFLE FILTER OR CHARCOAL FILTER MISSING [Er 42]:** Alarm tone sounds, **Lower Display** shows **“Er 42”**, **Upper Display** reads **“ERROR ALARM - CHECK BAFFLE, CHARCOAL, AND FILTER, COVER”**. The Filter Cover inside cabinet is not installed or secure. Either the Baffle or Charcoal Filter, or both, are missing or not installed properly. Open door, remove Cover and check for filters. It may be necessary to reseal each Filter to ensure that filter proofing switches are engaged. Install Filter Cover and tighten securely. Close and latch door.

**Error 49** will occur after door has been closed.
- ELEMENT BOX MISSING [Er 43]:** Alarm tone sounds, **Lower Display** shows **“Er 43”**, **Upper Display** reads **“ERROR ALARM - ELEMENT BOX MISSING”**. The Element Box Assembly has been removed for cleaning and not re-installed, or not connected properly. Secure element assembly and install correctly in unit.

**Error 49** will occur after door has been closed.

## 3.8.1 Resolving Controller Errors and Alarms - continued

<ul style="list-style-type: none"> <li>● <b>BASKET JAM [Er 44]:</b> Alarm tone sounds, <b>Lower Display</b> shows “<i>Er 44</i>”, <b>Upper Display</b> reads “<b>ERROR ALARM - BASKET JAM</b>”. During operation requiring basket movement, the basket drive system has become jammed or stalled. Open door, free basket and correct any problems.  Error 49 will occur after door has been closed.</li> </ul>
<ul style="list-style-type: none"> <li>● <b>FIRE SYSTEM PRESSURE [Er 47]:</b> Alarm tone sounds, <b>Lower Display</b> shows “<i>FirE</i>”, <b>Upper Display</b> reads “<b>ERROR ALARM - FIRE SYSTEM PRESSURE</b>”. All of the red indicator lights on Controller begin flashing and it is locked-out (keys disabled). Pressure in the extinguisher tank has fallen below the allowable limit for operation, or the system has been discharged. The unit is disabled until corrected. <u>Contact authorized fire protection service company for repair.</u>  Power must be removed from the unit to reset this error (unplug or turn <b>OFF</b> breaker in electrical panel).</li> </ul>
<ul style="list-style-type: none"> <li>● <b>FIRE SYSTEM LEVER [Er 48]:</b> Alarm tone sounds, <b>Lower Display</b> shows “<i>FirE</i>”, <b>Upper Display</b> reads “<b>ERROR ALARM - FIRE LEVER UNCOCKED</b>”. All of the red indicator lights on Controller begin flashing and it is locked-out (keys disabled). The Fire System arming lever is not in the “<b>cocked</b>” position and the system is not armed for operation. The unit is disabled until corrected. <u>Contact authorized fire protection service company for repair.</u>  Power must be removed from the unit to reset this error (unplug or turn <b>OFF</b> breaker in electrical panel).</li> </ul>
<ul style="list-style-type: none"> <li>● <b>PRESS [START] TO RESUME [Er 49]:</b> Alarm tone sounds, <b>Lower Display</b> shows “<i>Er 49</i>”, <b>Upper Display</b> reads “<b>PRESS [START] TO RESUME</b>”. This confirmation error is issued when cabinet door is closed after an event that required it to be opened. Heat will remain <b>OFF</b> until user confirms door closure by pressing [START].</li> </ul>
<ul style="list-style-type: none"> <li>● <b>ELEMENT BOX NOT ENGAGED [Er 50]:</b> Alarm tone sounds, <b>Lower Display</b> shows “<i>Er 50</i>”, <b>Upper Display</b> reads “<b>ERROR ALARM - ELEMENT BOX NOT ENGAGED</b>”. The Element Box/Pot Assembly is in the unit, but not fully positioned against the back wall of the cabinet, which could present a collision risk when basket is moved by the lift motor. Open door and push assembly farther into cabinet so that proofing switch on back wall is engaged.  Error 49 will occur after door has been closed.</li> </ul>

## 3.9 XPressFry Cooking Procedures

The XPressFry is designed for almost hands-free cooking. It is fully automatic and completely enclosed resulting in much less mess, while delivering fresh fried food directly from Fryer to server.

### IMPORTANT!

This appliance is not designed for cooking of fresh food items. It is intended to cook prepared frozen foods such as french fries, chicken, fish, breaded cheese, onion rings, breaded vegetables, etc. Attempting to cook fresh products containing high moisture could lead to significant cleanliness and sanitation issues.

1. Start the appliance as described in *Section 3.3, Start-up/General Operation*.
2. Select a Menu preset, or set a manual cooking temperature and time. See *Section 3.4.2, Selecting a Menu Preset for Cooking* or *Section 3.5, Setting a Manual Cooking Temperature and Time*.

3. The unit will enter **PREHEAT** mode if oil temperature is less than the active setpoint. **Upper Display** shows “PREHEAT”, **Lower Display** displays the real-time oil temp while heating. When oil has been heated to setpoint, alarm sounds and message “**SETPOINT REACHED**” is displayed. Press [**ALARM**] to acknowledge and put Controller into **READY** state; temperature displayed in **Lower Display** changes to setpoint temp.



4. When “**READY**” is displayed on **Upper Display**, open the lift knob on top of Chute to unlock. Grab chute handle and lower it slowly until it rests on the bumpers below and place the appropriate amount of frozen food product into the chute.

**CAUTION** The quantity that can be cooked in each load is highly dependent upon food type. **DO NOT** overfill the Loading Chute container. Doing so could result in Basket overflowing and cause excessive splash or pot overflow.

Never load the unit with more than one load at a time, this can cause the pot to overflow.



5. Using the chute handle, raise the chute up until the lock pin automatically engages. The food in the chute will then slide into the cook pot. Press the [**START**] key to begin the selected cook cycle. The **Upper Display** changes from “**READY**” to “**COOKING**” and programmed cook time (mm:ss) is displayed in the **Lower Display** and counts down, showing time remaining. **Ensure a suitable food pan is placed under the discharge chute at front of unit**

**IMPORTANT!!** The Chute must remain closed during entire cooking cycle.

6. When cooking time has expired, an alarm sounds, the **Lower Display** changes back to show setpoint temp, and the **Upper Display** shows message “**PLEASE WAIT EJECTING FOOD**”. The Cook Basket automatically lifts and proceeds through the dump cycle (raise, drain, shake, dump); the red **BASKET** indicator is **ON** while basket is operating. Pressing [**ALARM**] key silences the alarm.

**NOTE:** The Basket may bump against the cabinet to help dislodge product ... **this is normal**.

7. Basket returns to the ready position in pot after dumping. If the oil is at setpoint temp, **Upper Display** will read “**READY**” and Fryer is ready for the next load. If the oil has not yet returned to setpoint temperature, display reads “**PREHEAT**” and oil begins heating. **DO NOT** dump another load until “**READY**” is displayed. In most cases there should be little or no delay.

## 3.9 XPressFry Cooking Procedures - continued

### **WARNING**

DO NOT operate the unit unless oil level is at or above the {ADD} mark on Pot wall. If the element energize when it is not completely covered with oil (or only barely covered), there is a significant risk of fire.

- As safeguard against low oil level, after eight (8) loads have been cooked, the Controller goes into [Er 41] alarm and displays message *"OPEN DOOR, CHECK OIL LEVEL"*. Pressing [ALARM] key silences alarm. To be able to continue cooking, User must open door, check oil and add if level is below the [ADD] mark. Failure to maintain oil level between [FULL] - [ADD] can cause excessive smoking, poor food quality and potentially result in FIRE!

Close and latch door. Alarm sounds and message *"PRESS [START] TO RESUME"* is displayed. Press [ALARM] to acknowledge, then Fryer returns to *READY* state.

- To repeat the same cook cycle, simply load the next batch of product into Fryer and press [START] to begin cooking.  
—OR—  
Select a different Menu Item preset (or input different manual temp and time) as shown in **Step #1**.

### 3.9.1 Cancelling a Running Cook Cycle

- To cancel a running cook cycle before it is complete, press the [CLEAR] key.
- The **Upper Display** will display the following prompts:  
[CLEAR] TO STOP  
[START] NEW TIME  
[<] RESUME
- Press [CLEAR] key a second time to **STOP** the running cook cycle. The Basket will energize and proceed with the dump cycle to remove product. **Upper Display** shows the message *"PLEASE WAIT, BASKET OPERATING"*.
- Press [START] key to continue cooking with a new (or additional) time. Using keypad enter **TIME** (mm:ss), then press [START]. Press [START] again to begin the new time counting down.
- Press [<4] key to resume the current cook cycle.

Controller returns to **READY** state when finished.



## 3.10 Sleep Mode/Power-Off

1. Pressing the **[POWER]** button puts the Controller into **SLEEP** Mode. Oil begins to cool. Temperature must cool to **200°F** before Controller displays will turn **OFF** and exhaust fan stops. The red LED indicator above the **[POWER]** button flashes, signaling user that unit is in **SLEEP** mode.
2. Pressing the **[POWER]** button again brings unit out of **SLEEP** mode, and Controller issues the **“OPEN DOOR, CHECK OIL LEVEL”** alarm

To completely remove power from the appliance, the power plug must be removed from the receptacle, or the circuit breaker in the electrical panel supplying power to the receptacle must be turned **OFF**.



## 3.11 High Temperature Safety Shutdown (High-Limit Tripped)

The **XPressFry** is equipped with a high-limit temperature (**575°F rated**) safety thermostat, which will turn-off and disable the heating element if a “runaway” temperature condition occurs. This safety thermostat operates independently of the temperature controller to safeguard against excessively high and dangerous temperatures that could cause fire. If high-limit shutdown is activated, the red indicator above the **[HEAT RESET]** button turns **ON** ... the appliance **WILL NOT** heat until the safety thermostat is reset.

1. Some possible causes for High-Limit shutdown:
  - Excessive low oil level in the Cook Pot ... below Controller temperature probe.
  - Faulty temperature probe ... not sensing temperature correctly.
  - Faulty Controller or component.
2. Indications that a high temperature condition has occurred:
  - **[HEAT RESET]** red indicator light **ON**
  - Burned or badly over-cooked food.
  - Sudden presence of smoke.
  - Oil beginning to cool even though Controller in **PREHEAT**.



### **⚠ WARNING**

**DO NOT** continue to operate the appliance when a high-limit condition continues to occur. Doing so can damage the appliance, increase the possibility for a fire, and possibly void the warranty. Have a qualified equipment service technician evaluate the unit and repair.

## 3.12 Resetting the High-Limit Safety Thermostat

### **CAUTION**

DO NOT continue to use the appliance if numerous high-limit shutdowns are repeatedly occurring. This could be an indication of equipment malfunction ... service by a qualified technician may be required.

### **NOTE:**

The High-Limit Thermostat will **NOT** reset until the temperature the sensor is reading is below 450°F.

Follow the steps below to reset Thermostat.

1. If a cook cycle was running, cancel it (**Section 3.9.1**), allow product to be dumped from the Basket.
2. Allow oil and pot to adequately cool (**below 450°F**).
3. Before attempting to reset the Hi-Limit, open cabinet and ensure that cooking oil level is at or near the **[FULL]** level mark on the pot. Controller will issue a **"DOOR OPEN"** alarm; press **[ALARM]** to silence. Close Door and press **[START]** to continue.
3. Press the **[HEAT RESET]** Button on the front panel to reset the Thermostat. If oil temperature has cooled sufficiently, the **Red Indicator Light** will turn **OFF**. Thermostat is now reset.

**IMPORTANT!** If red **HEAT** indicator is **ON** and the **Upper Display** shows **PREHEAT**, actual oil temp is below setpoint. If this is the case, the heating element will immediately turn **ON** when the hi-limit is reset.



### **NOTE:**

Removing the Element Assembly from the appliance will also cause the Red Indicator Light to illuminate, indicating that the heating element circuit has been disabled. After reinstalling the assembly in the unit the **HEAT RESET** button must be pressed to re-enable the heating element for normal operation.



## 4. Filter Maintenance

The following section describes maintenance of the filters contained in the Ventless air filtration system of the XPress-Fry.

### 4.1 General Information

- The appliance features a self-contained air cleaning and filtration system, which when properly maintained will allow operation of the appliance without the need for a separate hood and duct system for venting to the outside.
- The system consists of an Exhaust Fan that draws grease-laden vapor, produced by frying, across two (2) separate Filters, which capture and remove grease particulate from the air stream, then freshens the air before discharging it back in the room.
- **Stainless Steel Baffle Filter:** First stage filtration captures larger airborne grease particulate. This filter is washable and reusable. It should be cleaned daily.
- **Activated Charcoal Filter:** Second stage filtration captures fine grease particulate and the activated charcoal aids in removing cooking aromas to freshen the air before being exhausted. **IT IS A ONE-TIME USE, DISPOSABLE FILTER THAT CANNOT BE CLEANED AND RE-USED ... REPLACE ONLY.** The filter must be replaced when it becomes saturated to the point of restricting airflow below the minimum for vapor capture. This is typically every 60 to 90 days, depending on hours of operation and food types cooked.
- **Filter Interlocks:** **1. Filter Missing** - interlock prevents the heating element from operating if any filter is missing or improperly installed, **2. Clogged Filter** - air pressure switch monitors airflow through the filters and will disable the heating element if flow drops below minimum, **3. Filter Cover Missing** - interlock prevents the heating element from operating if the Filter Cover is missing or improperly installed. Controller issues alarms and user prompts in each case.

### 4.02 Filter System, Filter Maintenance & Filter Alarms

Filter	When to Clean/ Replace	How to Remove	How to Clean	How to Install
Baffle Filter	Clean Daily	Section 4.3	Section 4.5	Section 4.4
Charcoal Filter	Replace every 60 - 90 days <b>P/N 41389</b>	Section 4.3	<b>Replace ONLY! NOT REUSEABLE DO NOT attempt to clean.</b>	Section 4.4

## 4.3 Removing Filters

Filters are located on the left side of the back wall inside the Cabinet, secured in place by Filter Access Cover panel, which is held by swing latch. The Filters can be removed without removing the Pot/Element assembly.

### **CAUTION**

Ensure that the appliance has been powered down (SLEEP mode) and is adequately cooled before removing filters. DO NOT attempt filter removal while unit or cooking oil is still HOT!

**1**

Latch

Filter Access Cover

**2**

Charcoal Filter

**3**

Baffle Filter

**1.** Swing latch upward to open the Filter Access Cover. The two filters are exposed for easy removal.

**2.** Charcoal Filter (top) ... Grasp and slide it straight out of the filter chamber rack.

**3.** Remove the Baffle Filter (lower). Slide upward out of the filter pocket; turn slightly so that it is parallel to frame (as shown above) and pull straight out.

## 4.4 Installing Filters

Re-installed Filters in the reverse manner of removal.



**Filter Interlock Switches:** An interlock switch is located behind each filter. These switches must be engaged by each of the filters when installed. If the filter is missing, or improperly installed such that the switch is not activated, a Filter Missing alarm is displayed and the heating element is disabled until the condition is corrected.

1. Install the Baffle Filter in reverse of removal. **Note the airflow arrow on the side of the filter; it must point upward.**
2. Install the Charcoal Filter and slide straight into the chamber in the guide channels. **Unless installing a new filter, it is advisable to install the same side down that was facing downward when removed.**

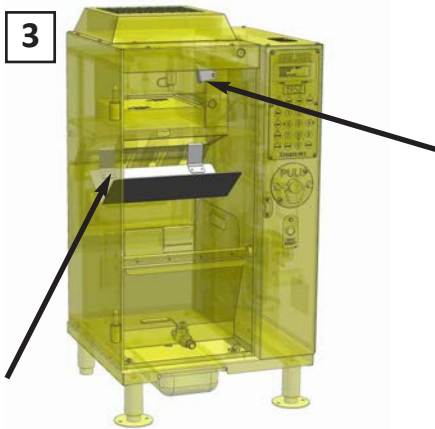
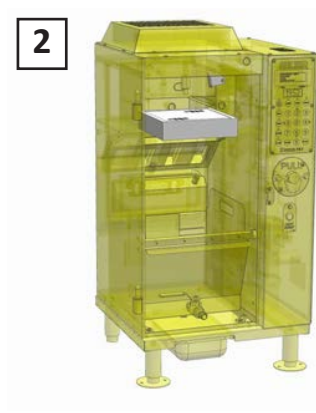
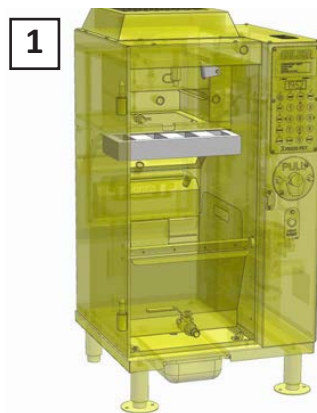

3. Install the Filter Access Cover ... fit the offset gap of the two brackets on the Cover over edge of the Baffle Filter pocket. Rotate the Cover upward and swing the latch downward to secure the cover. Ensure the latch is in place and the Cover is secure.

**When installed, the Cover must activate an interlock switch ... the unit will not heat if the switch is not engaged.**

Interlock Switch behind Cover



## 4.5 Cleaning the Baffle Filter

The Baffle Filter should be cleaned **daily** to ensure best performance.

1. Remove Baffle Filter as described in **Section 4.3, Removing Filters**.
2. Wash Filter in the sink with warm soapy water, or use a mild degreasing cleaner, such as Simple Green. Rinse thoroughly in a clean hot water rinse. The Filter is also dishwasher safe.
3. Dry thoroughly, then reinstall in the unit as described in **Section 4.4, Installing Filters**.

### IMPORTANT!

**DO NOT** place a wet filter into the appliance. It is preferable to allow the filter to air-dry overnight.

## 4.6 Charcoal Filter Replacement

### CAUTION

The Charcoal Filter **CANNOT** be cleaned and reused! Filter is a single-use, consumable, item that can only be replaced after use. Never attempt to wash the Charcoal Filter for reuse in the unit, doing so can cause damage to the unit and will void the warranty.

The Charcoal Filter should be replaced, at a minimum, every 60 to 90 days.

-- OR --

If it becomes saturated to the point of reducing airflow through across the filters below the minimum required for effective air cleaning. Low airflow will trigger the **"FILTER CLOGGED"** alarm which causes the heating element to be turned **OFF**.

1. Remove the used Charcoal Filter as shown in **Section 4.3, Removing Filters**. **DISCARD** the old filter.
2. With a damp cloth or sponge, clean away any grease residue that may have accumulated on the walls and filter guide channels. Use a mild degreasing cleaner, such as Simple Green, if needed.
3. Install a new Charcoal Filter (**Giles P/N 41389**) into unit as shown in **Section 4.4, Installing Filters**.
4. Record the date of replacement on the filter frame with a permanent marker.

### IMPORTANT!

Always use replacement Charcoal Filters supplied by *Giles Food Service Equipment*. Filters can be ordered from an authorized Dealer or Parts Distributor. Call 800.554.4537 or email [services@gfse.com](mailto:services@gfse.com) to locate one near you.

**Failure to use Giles OEM Filters or OEM replacement parts could void the factory warranty.**

## 4.6 Charcoal Filter Replacement - continued

### NOTE:

- The actual frequency with which the Charcoal Filter needs to be replacement is highly dependent on the type and quantity of foods cooked, and hours of operation.
- Maintaining a clean Baffle Filter will help extend the useful life of the Charcoal Filter.
- The ***"FILTER CLOGGED"*** alarm can be caused by conditions other than a saturated Charcoal Filter. Before exchanging the filter be certain that; **a).** there is nothing obstructing the inlet opening of the filters inside the cabinet, **b).** the Baffle Filter is clean, **c).** nothing is obstructing the discharge outlet on top of the unit, there should be 8" clearance above the top of cabinet.



## 5. General Maintenance

The following section describes general maintenance and cleaning procedures necessary to keep the **XPressFry** in peak operating condition.

### **⚠ DANGER**

- **NEVER** wash down the appliance interior, or exterior, with water from a spray hose.
- Failure to comply with these **DANGER** notices will result in serious injury, or death, equipment or property damage, and void the equipment warranty.

### **CAUTION**

- When cleaning the appliance:
  - **DO NOT** steam clean or spray with water.
  - **DO NOT** use products containing chlorine or other caustic chemicals.
  - **DO NOT** use highly abrasive products, steel wool or scouring pads.
  - **DO NOT** use oven cleaners.
- Failure to comply with these **CAUTION** notices may result in equipment or property damage, violate health and sanitation regulations, or void the equipment warranty.

### 5.1 Daily Cleaning

1. With door closed and unit power **ON**, press the **[CLEAN]** key on the Controller. Unit enters **CLEAN** mode, Basket operates, rising to a position that allows for easy removal. **"Cln"** is displayed on **Lower Display**. Allow unit to cool. **NOTE:** Unit cannot be powered **OFF** when in **CLEAN** mode.
2. Remove and wash the following items in warm soapy water, followed by a clean hot water rinse (refer to Sections noted for installation/removal information):
  - Non-stick Cook Basket, **Section 2.12.**
  - Food Loading/Delivery Assembly, **Section 2.7.**
  - Grease Baffle Filter, **Section 4.3**
  - Filter Access Cover, **Section 4.3.**
  - Under-Cabinet Drip Pan
3. Thoroughly dry all parts.
4. Remove the Charcoal Filter and wipe down the exterior surfaces with a clean damp cloth or paper towels. **WIPE ONLY ... NEVER ATTEMPT TO WASH THE CHARCOAL FILTER ... DOING SO WILL DAMAGE THE CHARCOAL MEDIA AND MAKE THE FILTER UNUSABLE.**
5. Clean grease accumulation from accessible interior surfaces using sanitized towels, or paper towels, along with a mild degreaser, such as **Simple Green®**. If the cooking oil in the Pot is to be retained, avoid using spray cleaning products inside the cabinet, which could result in contamination of cooking oil. If spray products are to be used, take proper precautions to avoid contamination. **Exercise care when cleaning near the fire system cable and detector link to avoid accidental system discharge.**

## 5.1 Daily Cleaning - continued

6. Sanitize all parts and interior surfaces in accordance with prevailing local health and sanitation regulations.
7. Clean the exterior of the appliance with a good quality stainless steel cleaner/polish.
8. Replace the clean, dry components. Refer to the Manual Sections above for installation information.  
Check oil level in the pot and add liquid shortening, as needed. Maintain oil level between [ADD] and [FULL] marks.
9. Close the cabinet Door. Press the [CLEAN] key on the Controller, follow prompts on **Upper Display**.
  - > Press [START] to exit **CLEAN** mode and return Basket to the “home” position.
  - > Press [CLEAN] key again to remain in **CLEAN** mode.

## 5.2 Weekly Cleaning

1. Perform the Daily Cleaning procedure (see **Section 5.1**).
2. Remove used oil from unit using Drain Hose (see **Section 5.7**), and then remove the Pot/Element Assembly.
3. Dispose of waste oil in accordance with prevailing Federal, State and/or Local regulations. If the capability is available, oil can be routinely filtered and reconditioned for reuse. Filtering can extend oil life by as much as 50%. Even with filtering, it is recommended that oil be disposed of and replaced after 7 to 14 days of use.
4. Clean the Pot and Element Assembly as described in **Section 5.7**
5. Clean interior surfaces which are usually covered by the Pot/Element Assembly. Sanitize parts and interior surfaces in accordance with prevailing health and sanitation regulations.
6. Check the fire extinguisher pressure gauge through sight glass on right side of the Cabinet. If the indicator is not within the “green” operating range, have the unit serviced immediately by a certified fire protection equipment service technician. **DO NOT operate the appliance until the extinguisher has been serviced. The appliance WILL NOT heat should extinguisher pressure fall below the allowable limit and a FIRE SYSTEM PRESSURE alarm will be issued.**
7. Visually inspect extinguisher spray nozzles and blow-off caps inside the cabinet and filter plenum chamber. Replace missing or damaged caps.
8. Re-install the Pot/Element Assembly, and refill pot with fresh shortening as described in **Section 5.7**.

## 5.3 Monthly Safety Interlock Inspection

The **XPressFry** is designed with safety interlocks to ensure that the appliance operates safely and effectively. The function of these interlocks should be tested monthly to ensure continued proper operation.

### NOTE:

While monthly inspections can be adequately performed by trained and experienced Users, Giles highly recommends that qualified service technicians perform them, if possible. This will allow malfunctions to be detected and quickly repaired.

## 5.3 Monthly Safety Interlock Inspection - continued

The appliance is equipped with interlock safety switches for the following:

- Cabinet Door
- Charcoal Filter
- Clogged Filter
- Filter Access Cover
- Baffle Filter
- Pot/Element Assembly positioning

Each must be individually tested according to the procedure shown below. The appliance must be powered up and in the **READY** state when conducting these tests.

### IMPORTANT!

To verify that the heating element is being disabled when the interlock is open, these tests need to be performed while the unit is in **PREHEAT** mode. To conduct tests, begin with cold oil, e.g. at the beginning of the day. Power up unit and set a manual temp setting of 330 - 350°F then immediately start the checks.



These procedures require that the Door be opened and closed several times during the process. Use due caution with regard to the oil heating in the Pot.

The “**DOOR OPEN**” alarm occurs each time Door is opened. Press [**ALARM**] key to the silence tone, or it silences automatically after 10 secs. After closing Door the “**PRESS [START] TO RESUME**” alarm occurs; press [**START**] to continue.

Ensure that unit is in **PREHEAT** mode and the red **HEAT** indicator on Controller is **ON**.

1. **Cabinet Door** - Open cabinet Door. Alarm sounds; **Lower Display** reads “door”; **Upper Display** reads “**ALARM DOOR OPEN**”. The fan continues to run. Red **HEAT** indicator should turn **OFF**.
2. **Filter Access Cover** - While door is open for step-1, remove the Filter Access Cover. Alarm sounds; **Lower Display** reads “**Er42**”; **Upper Display** reads “**ERROR ALARM, CHECK BAFFLE, CHARCOAL, AND FILTER COVER**”. The fan will turn **OFF**. Close Door and latch; alarm condition should remain and red **HEAT** indicator should remain **OFF**.
3. **Charcoal Filter** - Open door, remove only the Charcoal Filter from the chamber. Install and secure the Filter Access Cover, then close and latch the cabinet door. **Alarm status of the unit should remain as described in step-2.**
4. **Baffle Filter** - Open door and remove Filter Access Cover. Remove the Baffle Filter from the chamber, then replace the Charcoal Filter. Install and secure the Filter Access Cover, then close and latch cabinet door. **Alarm status of the unit should remain as described in step-2.**

Reinstall both Filters, place and secure Filter Cover, and close and latch door. Press [**START**] to acknowledge “**PRESS [START] TO RESUME**” alarm; unit should return to **PREHEAT** mode and red **HEAT** indicator turns **ON**.

5. **Clogged Filter** - With the door closed and unit in **PREHEAT** mode, place a flat piece of cardboard, or other suitable material, to completely block the exhaust outlet on top of the appliance. The fan will operate momentarily, then lack of airflow will cause an alarm to sound. **Lower Display** reads “**Er23**”; **Upper Display** reads “**ERROR ALARM, FILTER CLOGGED**”. The fan will turn **OFF** ... Red **HEAT** indicator should turn **OFF**.
6. **Pot/Element Assembly** - **DO NOT attempt to test this interlock with oil in the Pot; perform the check when cleaning the Pot and Element.** When installing Pot/Element after cleaning place it such that the plugs are engaged, but only slightly. Close door and power-up unit. An alarm should immediately sound; **Lower Display** reads “**Er50**”; **Upper Display** reads “**ERROR ALARM, ELEMENT BOX NOT ENGAGED**”. Controller is locked out. Open and fully engage element, unit should immediately enter “**DOOR OPEN**” alarm.

## 5.3 Monthly Safety Interlock Inspection - continued

Should any test fail to yield the results described, further evaluation, troubleshooting and repair is required immediately by a qualified food service equipment technician. **The heating element is disabled as long as an alarm condition is present.**

### **CAUTION**

**DO NOT attempt to operate the appliance unless all interlocks are operating as intended and DO NOT attempt to by-pass an interlock. Doing so could result in poor performance, damage to the appliance, damage to property, and possibly void the factory warranty.**

## 5.4 Quarterly Cleaning and Maintenance

1. Perform the routine Weekly Cleaning and Monthly Inspections.
2. Remove both Filters and thoroughly clean all interior surfaces of the filter chamber, using a mild degreasing cleaner, such as *Simple Green*®.
3. Install **new** Charcoal Filter ... typically, the filter should be replaced every three (3) months regardless of whether it has become saturated to the point of clogging or not.

**Use only replacement Filters supplied by Giles (P/N 41389).** Filters can be purchased through authorized *Giles* Food Service equipment dealers or parts distributors. Call **800.554.4537** or email **[services@gfse.com](mailto:services@gfse.com)** to locate a nearby dealer.

**Failure to use Giles OEM replacement Filters may void the factory warranty.**

## 5.5 Fire Extinguishing System Maintenance

The Wet Chemical Automatic Fire Extinguishing system in the **XPressFry** must be inspected and maintained in accordance with current **NFPA 17A** standards.

An **Extinguisher Operations, Inspection, Maintenance & Recharge Manual** was provided with the appliance. Please refer to that manual, **Section 4, Routine Inspection & Maintenance**, for details and procedures related to:

- Owner/User six (6) month inspection.
- Semi-annual (6 month) Maintenance and Inspection, must be performed by a qualified fire equipment service company.
- 12-Year Maintenance and Inspection, must be performed by a qualified fire equipment service company.

**Inspection, service, maintenance and recharging of the Fire Extinguishing System must be performed by an appropriately certified fire protection equipment service company, in accordance with NFPA 17A.**

**Recharge the fire extinguisher system immediately after any discharge!**  
**Appliance will not operate unless system is fully charged.**

## 5.6 Maintaining the Cooking Oil

- Regular monitoring and maintenance of cooking oil in the **XPressFry** is extremely important for peak cooking performance, and enhancing the taste and flavor consistency of fried foods.
- **Oil Level** - Oil level in the Cook Pot must be maintained between the **[ADD]** and **[FULL]** marks, with no product in pot. After every eight (**8**) cook cycles, the Controller issues a “**CHECK OIL**” alarm. When the alarm occurs open the cabinet door and press the **[ALARM]** key. Confirm that oil is at the proper level; add liquid shortening if necessary and stir in. Close door and press **[START]** to clear the “**PRESS [START] TO RESUME**” alarm.

**NOTE: This alarm disables the heating element until the cabinet Door is opened and re-closed.**

- **Replacing Cooking Oil** - The frequency with which the oil is changed (or filtered) will vary widely depending upon the type and quantity of foods being cooked. Monitoring kits are commercially available and provide the most accurate method of determining the condition of oil. As a general rule, shortening should be changed at least weekly as part of the **Weekly Cleaning (Section 5.2.)**.
- **Filtering Oil** - Filtering for reuse is an alternative to replacing shortening. Generally, this can lower operating expense as oil life can be increased by up to 50%. Filtering involves removing used oil from the appliance and processing it through speciality filtering equipment (**provided by User**). With use of proper filter media and a good quality filter aid, the process cleans and re-conditions the oil, removing residue and free fatty acids which form during cooking. Different makes and models of filtering equipment are available commercially from kitchen equipment suppliers.

**Giles makes no recommendation with regard to the equipment that would be best suited for any specific application.**

## 5.7 Removing Cooking Oil from the Appliance

### CAUTION

Cooking oil and components within the cook chamber are typically extremely HOT! Use due diligence when handling ... it is advisable to wear thermal protection, such as oven mitts or gloves, to avoid possible burn injury.

Before attempting to remove waste oil, press **[POWER]** key to place unit into SLEEP mode and allow the cool down process to proceed until the exhaust fan stops. Oil should then be at 200°F and suitable for draining

To facilitate the process of removing cooking oil from the **XPressFry**, the Cook Pot features a Drain Valve. The provided 43” flexible hose can be readily attached to the valve for draining.

**NOTE: Cold congealed oil will not readily drain from the Pot. Oil should be heated to least 200°F to flow easily through the drain hose. The best time to drain is immediately after powering off while oil is still fairly hot.**

1. If not already done, press **[POWER]** key to place unit into **SLEEP** mode and wait until the exhaust fan stops running. Press **[POWER]** key again to exit **SLEEP** mode. “**OPEN DOOR, CHECK OIL LEVEL**” sounds. Press **[CLEAN]** key to enter **CLEAN** mode, then open Door and remove the Basket (see **Section 5.1, Step 1**).

## 5.7 Removing Cooking Oil from the Appliance - continued

2. Push the male end of the Drain Hose onto the valve to connect.
3. Insert the other end of hose into a suitable heat resistant container and open the valve.
4. Allow waste oil to drain from Pot.

**NOTE: When using the hose, Pot will not completely drain, approximately 3/4" inch of the oil will remain.**

5. Close Valve and remove hose. Drain oil remaining in hose into the waste oil container.

6. Grasp Element Assembly handle and Pot front lip. Pull both forward together to disconnect Pot/Element Assembly from receptacles. Carefully remove Element and Pot from cabinet. Lift Element Assembly out of Pot and allow to drain. Pour oil and residue remaining in the Pot into the waste oil container. Wipe out excess with paper towels.

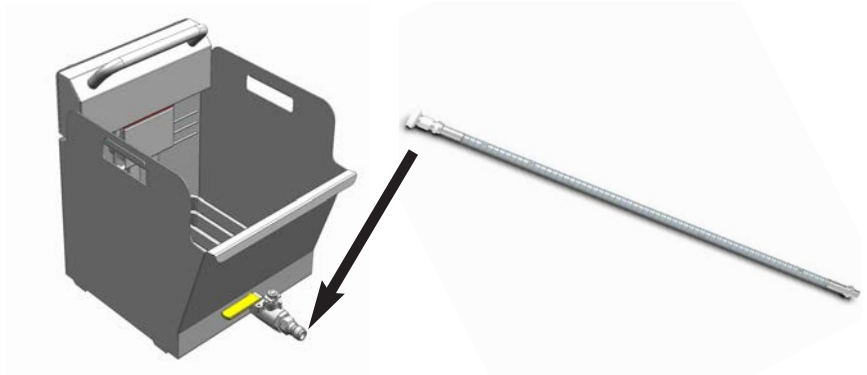

## 5.8 Refreshing Cooking Oil in the Appliance

### **CAUTION**

- **NEVER immerse the upper box of the Element Assembly in water. Doing so can cause permanent damage and void the warranty.**
- **When cleaning element, take care not to bend or damage temperature sensors.**

**Before replenishing the unit with fresh oil, thoroughly clean Pot, Element Assembly, and Cook Basket.**

1. Clean Pot with warm soapy water or a mild biodegradable degreasing cleaner, such as **Simple Green®**. As needed, scrub with soft-bristle brush to remove residue. **DO NOT use oven cleaners or other caustic cleaners.** Rinse thoroughly with clean hot water and dry.
2. Clean heating element with warm soapy water or a mild biodegradable degreasing cleaner, such as **Simple Green®**. Use a stiff-bristle brush and clean between the element bars to remove residue from all surfaces. Rinse thoroughly with clean hot water and dry.

**DO NOT immerse or spray the upper box of Element Assembly with water.**

3. Clean Basket with warm soapy water or a mild biodegradable degreasing cleaner, such as **Simple Green®**. As needed, scrub lightly with a soft-bristle brush to remove residue. **DO NOT use oven cleaners or other caustic cleaners, as it will damage the non-stick coating.** Rinse thoroughly with fresh hot water and dry. The Basket may also be washed in the dishwasher.
4. Ensure that all pieces are **completely dry**.
5. Place Element into Pot, slipping the small channel on bottom of element box onto the top of the rear Pot wall. Position Pot/Element Assembly in cabinet and slide to back. Engage the alignment pin, and element/thermocouple plugs on Element Assembly in the receptacles on the rear cabinet wall; push in firmly to fully seat plug. The interlock switch on cabinet wall must be fully engaged.

## 5.8 Refreshing Cooking Oil in the Appliance - continued

6. Ensure that the Pot Drain Valve is closed. Fill Pot with fresh liquid shortening only to the **[ADD]** mark, allowing room for expansion when heated.
7. Place the clean Basket into unit. **NOTE: Unit should still be in CLEAN mode, so basket position should be raised halfway, approximately.**
8. The red indicator light above the **[HEAT RESET]** button should be **ON**; press button to reset the hi-limit thermostat and enable the heating element.
9. Close and latch cabinet door. Press the **[CLEAN]** key, then press **[START]**. Basket will operate and return to the **“home”** position. **“OPEN DOOR, CHECK OIL LEVEL”** alarm sounds; open door, be sure oil is in the Pot, then close and latch. Press **[START]** to acknowledge the **“PRESS [START] TO RESUME”** alarm.
10. Unit enters **PREHEAT** mode and begins heating oil to the active setpoint. After oil heats and the **“SETPOINT REACHED”** alarm is issued, press the **[ALARM]** key to acknowledge and place unit into **READY** state.
11. Open door to verify oil level is between **[ADD]** and **[FULL]** after heating. If needed, top-off pot with fresh shortening to **[FULL]** mark and stir. Close and latch door, press **[START]** to acknowledge alarm.  
**The unit is ready for cooking.**

## 5.9 Maintenance Log

The Maintenance Log on the following page is provided for keeping a record of routine maintenance. Upon completion of tasks, the log should be checked-off, signed and dated. In some locales, keeping such a log may be required by the “authority having jurisdiction” (health, safety, fire marshal, etc).

Depending on local regulations, there also might be a requirement that the log be posted in a conspicuous place.



## 6. Troubleshooting

This troubleshooting section is mainly presented as a guide for trained and qualified technicians to assess certain appliance malfunctions. While some very basic troubleshooting can be performed by the User, most items in this Section should only be attempted by qualified technicians. A wiring diagram is attached to the inside of the back panel to aid with more in-depth analysis.

FAULT / CONDITION	POSSIBLE CAUSES	CORRECTIVE ACTIONS
<b>Appliance will not power-up</b>	Power cord not plugged into proper outlet.	Plug in power cord to the proper power supply outlet.
	Tripped circuit breaker or blown fuse.	Check circuit breakers at main electric panel or fuses in the appliance.
	Controller malfunction.	Service technician required.
	Incorrect Start-up Procedure	Verify start-up steps.
<b>Oil does not begin heating at power-up</b>	Alarm; display reads <b>“OPEN DOOR, CHECK OIL LEVEL”</b>	Open door and reclose. This is normal operating procedure.
	Temperature SETPOINT is less than actual oil temperature.	Adjust temperature SETPOINT.
	Faulty contactor or element.	Service technician required.
	Controller malfunction.	Service technician required.
	Faulty temperature probe.	Service technician required.
	<b>Alarm condition:</b> safety interlock open; filters, element plug, door, airflow, fire system.	Check controller displayed error alarms and correct the fault condition.
	<b>HEAT RESET</b> Light is on	Press reset button to start heating.
	<b>[START]</b> not pressed after closing door.	Press <b>[START]</b>
<b>Oil begins to cool down during normal cooking operations; will not heat.</b>	High-temperature limit safety shutdown has tripped. <b>HEAT RESET</b> Light in <b>ON</b>	Check actual oil temp. at controller to confirm high temp. Dump food & allow to cool. Press reset button after cooling. For repeated occurrence, service technician required.
	Safety interlock is open (filter, door, airflow or fire system).	Check controller displayed error alarms and correct the fault condition.
	Faulty element or sensor.	Service technician required.
	Control component malfunction.	Service technician required.

## 6. Troubleshooting

FAULT / CONDITION	POSSIBLE CAUSES	CORRECTIVE ACTIONS
<b>Excessive Smoking</b>	Old cooking oil (over-used)	Refresh shortening.
	Over temperature	Confirm controller maintaining temperature correctly, check setpoint.
	Element dirty	Clean element.
	Low oil level	Maintain oil level between <b>[ADD]</b> & <b>[FULL]</b> level marks in pot.
<b>Audible alarm</b> <b>Upper Display: ALARM DOOR OPEN</b> <b>Lower Display: door</b>	Door has been opened	Close & latch door
	Faulty door switch.	Replace switch, service required.
	Door has become mis-aligned or warped; not sealing tightly.	Service technician required
<b>Audible alarm</b> <b>Heat Light OFF</b> <b>Upper Display: ERROR ALARM</b> <b>CHECK BAFFLE,</b> <b>CHARCOAL, AND</b> <b>FILTER COVER</b> <b>Lower Display: Er42</b>	Baffle Filter is not installed or mis-aligned.	Check Baffle Filter; reinstall.
	Charcoal Filter is not installed or mis-aligned.	Check Charcoal Filter; reinstall.
	Filter Access Cover not installed	Securely install Cover panel
	Faulty filter interlock switch.	Replace switch, service required.
<b>Audible alarm</b> <b>Heat Light OFF</b> <b>Upper Display: ERROR ALARM</b> <b>FILTER CLOGGED</b> <b>Lower Display: Er23</b>	Plenum area has become obstructed or filter is clogged	Clear obstruction, replace charcoal filter, clean baffle filter.
	Air exhaust outlet on top of unit has become obstructed.	Clear obstruction.
	Faulty vacuum switch.	Replace switch, service required.
	Clogged vacuum switch hoses	Clean or replace hoses, service required.
	Vacuum switch needs adjustment	Service technician required.
<b>Audible alarm</b> <b>Heat Light OFF</b> <b>Upper Display: ERROR ALARM</b> <b>FIRE SYSTEM</b> <b>PRESSURE</b> <b>Lower Display: FirE</b> <b>Red Flashing</b>	Low charge pressure in the fire extinguisher tank.	Have tank and fire system serviced by qualified fire protection service company.
	Faulty tank pressure sensor switch or wiring problem.	Replace switch, service required.
	Fire system has been discharged	Requires qualified fire protection equip. service company to re-commission system.

## 6. Troubleshooting

FAULT / CONDITION	POSSIBLE CAUSES	CORRECTIVE ACTIONS
<b>Audible alarm</b> <b>Heat Light OFF</b> <b>Upper Display: ERROR ALARM</b> <b>FIRE SYSTEM</b> <b>LEVER</b> <b>Lower Display: <i>FirE</i></b> <b>Red LED's Flashing</b>	Fire system cocking lever is not in the "cocked" and armed position.	Service required by qualified fire protection equip. service company.
<b>Audible alarm</b> <b>Heat Light OFF</b> <b>Upper Display: ERROR ALARM</b> <b>ELEMENT BOX</b> <b>NOT ENGAGED</b> <b>Lower Display: <i>Er50</i></b>	Element/Pot assembly is not plugged in completely ... not positioned fully against back wall.	Check position, push assembly farther into unit. Switch on back wall must be engaged.
<b>Audible alarm</b> <b>Heat Light OFF</b> <b>Upper Display: ERROR ALARM</b> <b>BASKET JAM</b> <b>Lower Display: <i>Er44</i></b>	Basket has collided with pot, or other obstruction, and become stalled.	Open door, clear obstruction.
	Basket has become mis-aligned and is in a bind.	Open door, check basket installation, correct alignment.
	Malfunction of Basket Lift motor or mechanism.	Service technician required.
<b>Audible alarm</b> <b>Heat Light OFF</b> <b>Upper Display: ERROR ALARM</b> <b>OIL PROBE</b> <b>Lower Display: <i>Er13</i></b>	Faulty oil temp probe.	Service technician required.
	Possible Controller problem	Service technician required.



## 7. Parts List

This section lists various parts that are, typically, field replaceable on the **GXF XPressFry Countertop Fryer**. It is provided to aid qualified service technicians who are servicing or repairing this equipment. Repair of this equipment should only be attempted by training kitchen equipment service technicians.

### 7.1 Parts Ordering & Service Information

If assistance or repairs are required, please contact a Giles Manufacturer's Representative or equipment Dealer to assist with locating an authorized service provider in your area. For further assistance you may contact the **GILES Technical/Customer Service Support** as follows:

**IN THE UNITED STATES & CANADA call: 800.554.4537**

**ALL OTHERS call: 334.272.1457**

Normal business hours are 8:00 AM to 5:00 PM Central Time ... calls are handled by an automated answering system. Please follow the recorded prompts to reach appropriate support. If necessary after hours, leave voice mail message ... a representative should respond within 30 minutes.

Website: [www.gfse.com](http://www.gfse.com) Email: [services@gfse.com](mailto:services@gfse.com)

Our goal at Giles is to provide the highest possible quality of service and assistance. To help us accomplish this, please have the following information readily available when calling, along with a brief description of the problem being experienced. Please record the unit information in the table below for quick reference.

<b>Model:</b>	
<b>Serial Number:</b>	
<b>Voltage:</b>	
<b>Phase:</b>	



The information can be found on the Serial/Data Label located on the cabinet adjacent to the power cord.

## 7.2 Appliance Exterior



\* Hidden

NOTE:  
Food Pan to be provided by User.

## 7.2 Appliance Exterior

ITEM	PART NO.	QTY	DESCRIPTION
1	46300	1	PULL STATION, FIRE SYSTEM, MANUAL ACTIVATION
2	21381	1	XPRESSFRY CONTROLLER
3	20657	1	POWER CORD, NEMA 6-50 PLUG, 5700W & 7200W, 1-PH
	20683	1	POWER CORD, NEMA 15-30 PLUG, 8500W, 3-PH
4	41071	2	LEG, 4" ADJUSTABLE, FLOOR PLATE FOOT
5	41070	2	LEG, 4" ADJUSTABLE, REGULAR FOOT
6	80792	1	DOOR / CHUTE ASSEMBLY
7	42827	1	DOOR LATCH
8	21304	1	PUSHBUTTON SWITCH, HIGH LIMIT RESET
9	21340	1	INDICATOR LIGHT, RED, HIGH LIMIT
10	41631	1	INDEXING PLUNGER, PIN DIA 0.24, PIN LENGTH 0.47
11	80541	1	SHIM, INDEXING PLUNGER
12	11175	2	NUT, 8-32, HEX, CAP, S/S
13	41290	2	HINGE, ENTRY FLAP
14	10143	8	NUT, 6-32, CAP, ACORN, S/S
15	10626	6	SCREW, 8-32 X 3/8, FLAT HD, PH, SS
16	10413	6*	NUT, 10-32, CAP, SS, LOCKING
17	41367	2	BUMPER, PRESS-IN

\* Hidden

**NOTE:**  
Food Pan to be provided by User.

## 7.3 Cabinet Interior (Front)



\* Hidden

## 7.3 Cabinet Interior (Front)

ITEM	PART NO.	QTY	DESCRIPTION
1*	<a href="#">41389</a>	1	CHARCOAL FILTER, FIBER, 8 x 8 x 2
2*	<a href="#">41212</a>	1	BAFFLE FILTER, 5 x 12
3	<a href="#">94515</a>	1	FRY BASKET, NON-STICK COATED
4	94516	1	FRY BASKET AXLE
5	80807	1	COOK POT
6	<a href="#">40784</a>	1	BALL VALVE, 1/2", S/S with NON-STICK SEALS
7	41046	2	HINGE, REMOVABLE
8	80790	1	FILTER COVER PANEL, PLENUM
9	80540	1	FILTER COVER, LATCH
10	80806-57	1	COMPLETE ELEMENT ASSEMBLY, 5700W, 240V, 1-PH
	80806-72	1	COMPLETE ELEMENT ASSEMBLY, 7200W, 240V, 1-PH
	80806-85	1	COMPLETE ELEMENT ASSEMBLY, 8500W, 240V, 3-PH
11	41195	1	NOZZLE, 2-FLOW, AMEREX
12	10466	1	FILTER COVER, SCREW
13	41693	1	QUICK CONNECT, 1/2", MALE

\* Hidden

## 7.4 Element Assembly Detail

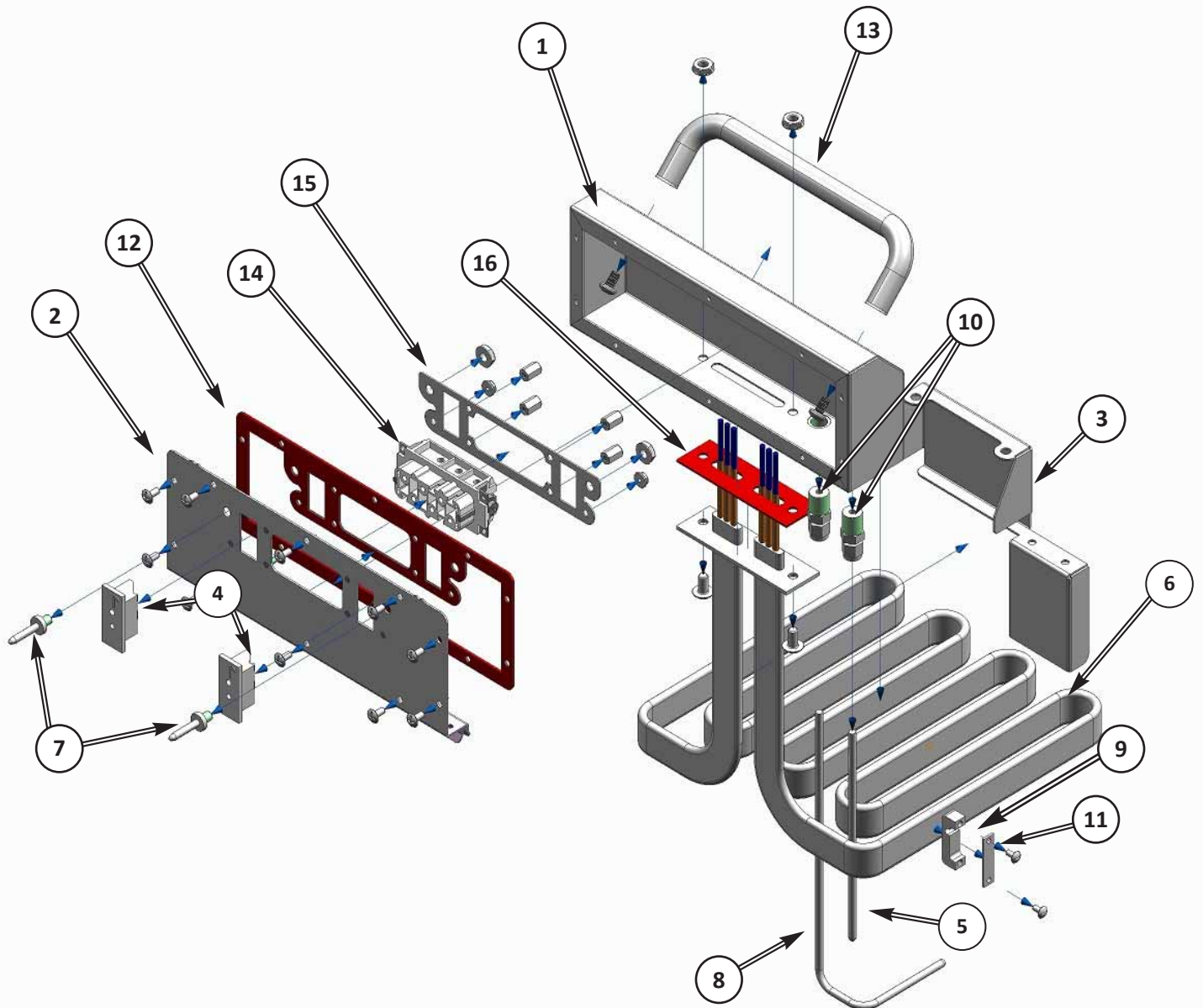

\* Hidden

## 7.4 Element Assembly Detail

ITEM	PART NO.	QTY	DESCRIPTION
1	80805	1	ELEMENT HOUSING, LOWER, WELD ASSY
2	80802	1	ELEMENT HOUSING, UPPER, WELD ASSY
3	80803	1	ELEMENT, BRACKET, PROBE
4	20538	2	CONNECTOR, THERMOCOUPLE, J, FEMALE
5	20534	1	THERMOCOUPLE, J, GROUNDED, 6.5 IN
6	20673	1	ELEMENT, 7200W, 240V, 1-PH
	20671	1	ELEMENT, 7200W, 240V, 1-PH
	20672	1	ELEMENT, 8500W, 240V, 3-PH
7	95209	2	ALIGNMENT PIN, MALE
8	21301	1	THERMOCOUPLE, HI-LIMIT
9	94834	1	BRACKET, THERMOCOUPLE, MATING
10	45400	2	CONNECTOR, 0.190 ID, 1/4NPT
11	94462	1	STRAP, ELEMENT BRACKET
12	99794	1	ELEMENT, GASKET, BACK PANEL
13	41628	1	ELEMENT, LARGE PULL HANDLE
14	20533	1	CONNECTOR, 6 POLE, 35 A, FEMALE
15	99795	1	ELEMENT, GASKET BRACKET, BACK PANEL
16	99796	1	ELEMENT, GASKET, ELEMENT

\* Hidden

## 7.5 Electrical Components, Right Side

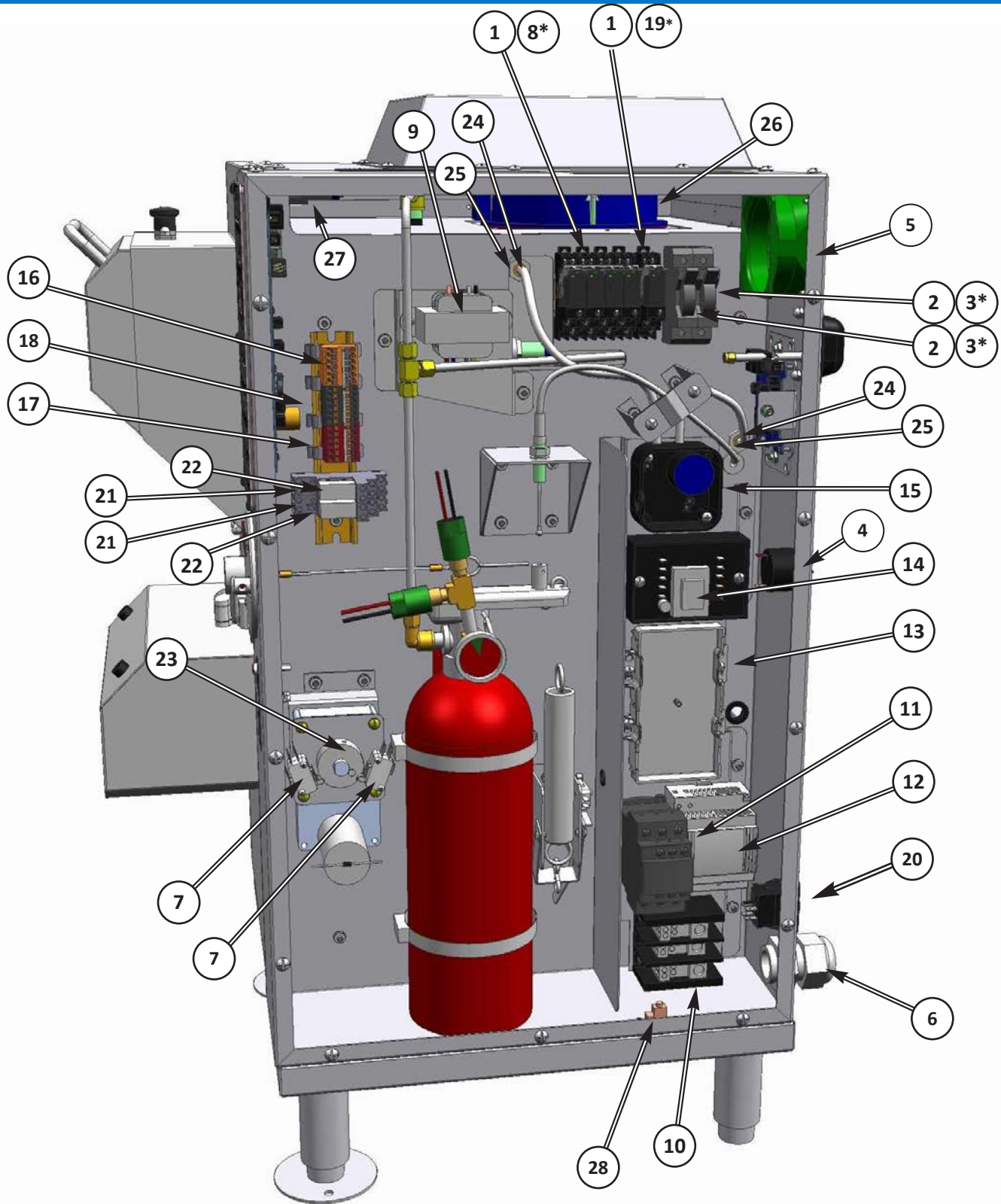

\*Hidden

Note: See Section 7.7 for Fire System detail.

## 7.5 Electrical Components, Right Side

ITEM	PART NO.	QTY	DESCRIPTION
1	21256	5	SOCKET, RELAY, SSR
2	20411	2	FUSE HLDR, DIN MOUNT,690V,32A
3*	21900	2	FUSE, 15-AMP, SC-15
4	22976	1	SONALERT, WATLOW TIMER,2-12VDC
5	20569	1	FAN, COOLING, 230V
6	41057	1	STRAIN RELIEF, 1" NPT, 0.75-1"
7	20545	4	SWITCH, CAM, MOTOR
8*	21255	4	RELAY, SSR, 5-15VDC INPUT, 1-48VDC LOAD
9	20366	1	TRANSFORMER, 9V, 117V,50/60 HZ
10	21164	1	BLOCK, DISTRIBUTION
11	21366	1	CONTACTOR, LONG LIFE,3POLE,40A, 100V-250V COIL
12	20540	1	POWER SUPPLY, 12VDC, 54W
13	20544	1	SWITCH, POWER, 208-240, 35A, 24VDC, 2 POLE
14	21305	1	LIMIT CONTROL, SAFETY, 575°F
15	20535	1	SWITCH, VACUUM, 0.16-1.2, HOSE CONNECT
16	21512	1	BLOCK,DISTRIBUTION,12-POLE,ORANGE, 12-26AWG
17	21509	1	BLOCK,DISTRIBUTION,12-POLE, RED, 12-26AWG
18	21509	1	BLOCK,DISTRIBUTION,12-POLE, BLACK, 12-26AWG
19	21442	1	RELAY, SSR, 3-15VDC INPUT, 24-280VAC LOAD
20	21190	1	SWITCH, ROCKER, ON-OFF, 250V, 10A, DPST
21	21438	2	SOCKET, RELAY, DIN RAIL
22	21437	2	RELAY, DPDT, 8 AMP, 240VAC COIL
23	21206	1	MOTOR, ELEVATOR, SHORT, 12VDC
24	94067	2	FITTING, VACUUM PICKUP
25	10535	2	NUT, 7/16-20 HEX, THIN, ZINC
26	20542	1	EXHAUST FAN, PLENUM
27	21502	4	SWITCH, PROXIMITY, INDUCTIVE, 24-240V
28	24221	1	LUG, GROUNG, COPPER, #6-14 WIRE

\*Hidden

Note: See Section 7.7 for Fire System detail.

## 7.6 Electrical Components, Rear

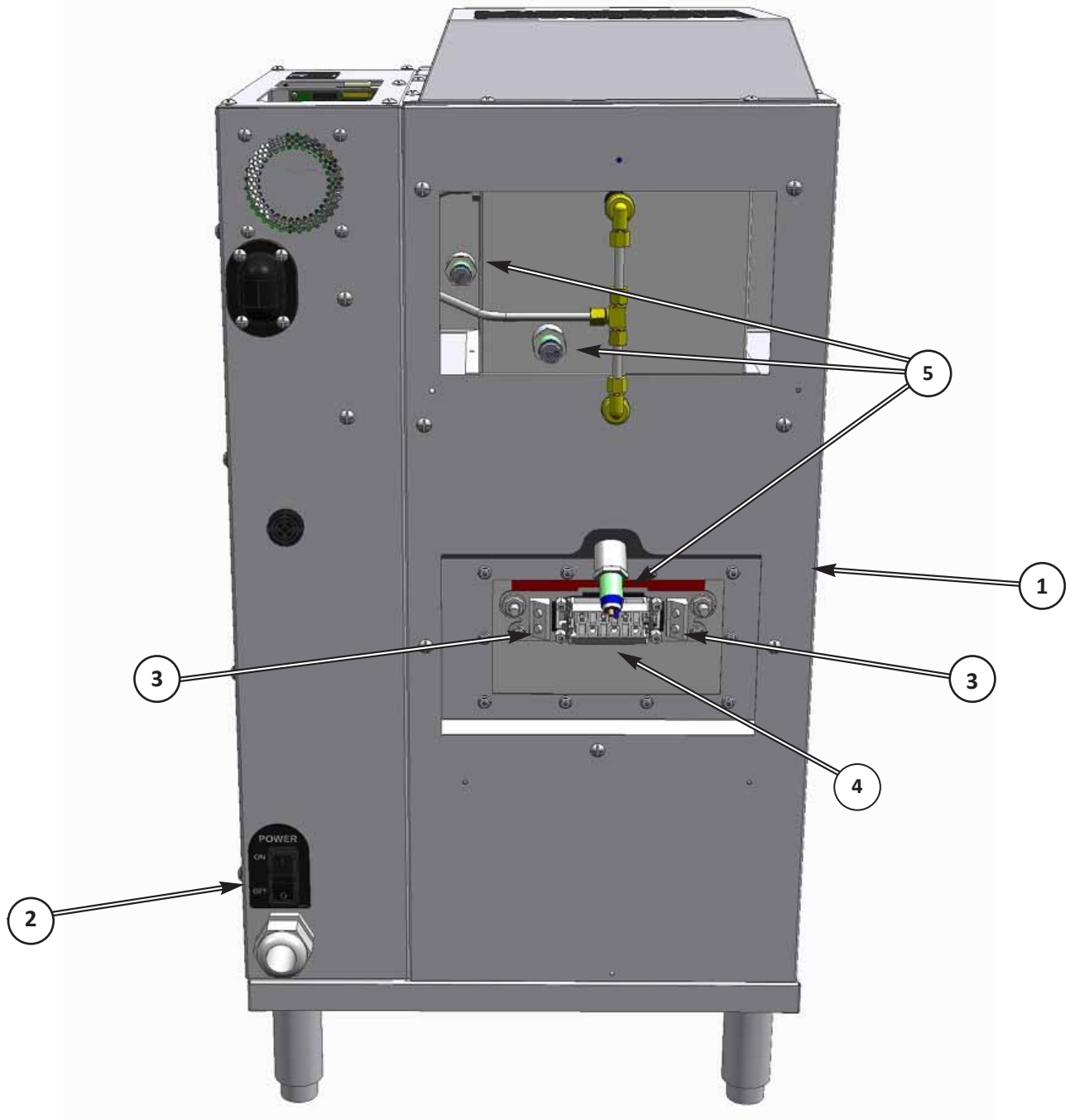

\*Hidden

Note: See Section 7.7 for Fire System detail.

## 7.6 Electrical Components, Rear

ITEM	PART NO.	QTY	DESCRIPTION
1	80786	1	PANEL, SIDE, BACK
2	<a href="#">21190</a>	1	SWITCH, ROCKER, ON-OFF, 250V, 10A, DPST
3	<a href="#">20539</a>	2	CONNECTOR, THERMOCOUPLE, J, MALE
4	<a href="#">20532</a>	1	CONNECTOR, 6 POLE, 35 A, MALE
5	21502	4	SWITCH, PROXIMITY, INDUCTIVE, 24-240V

\*Hidden

Note: See Section 7.7 for Fire System detail.

## 7.7 Fire Extinguishing System

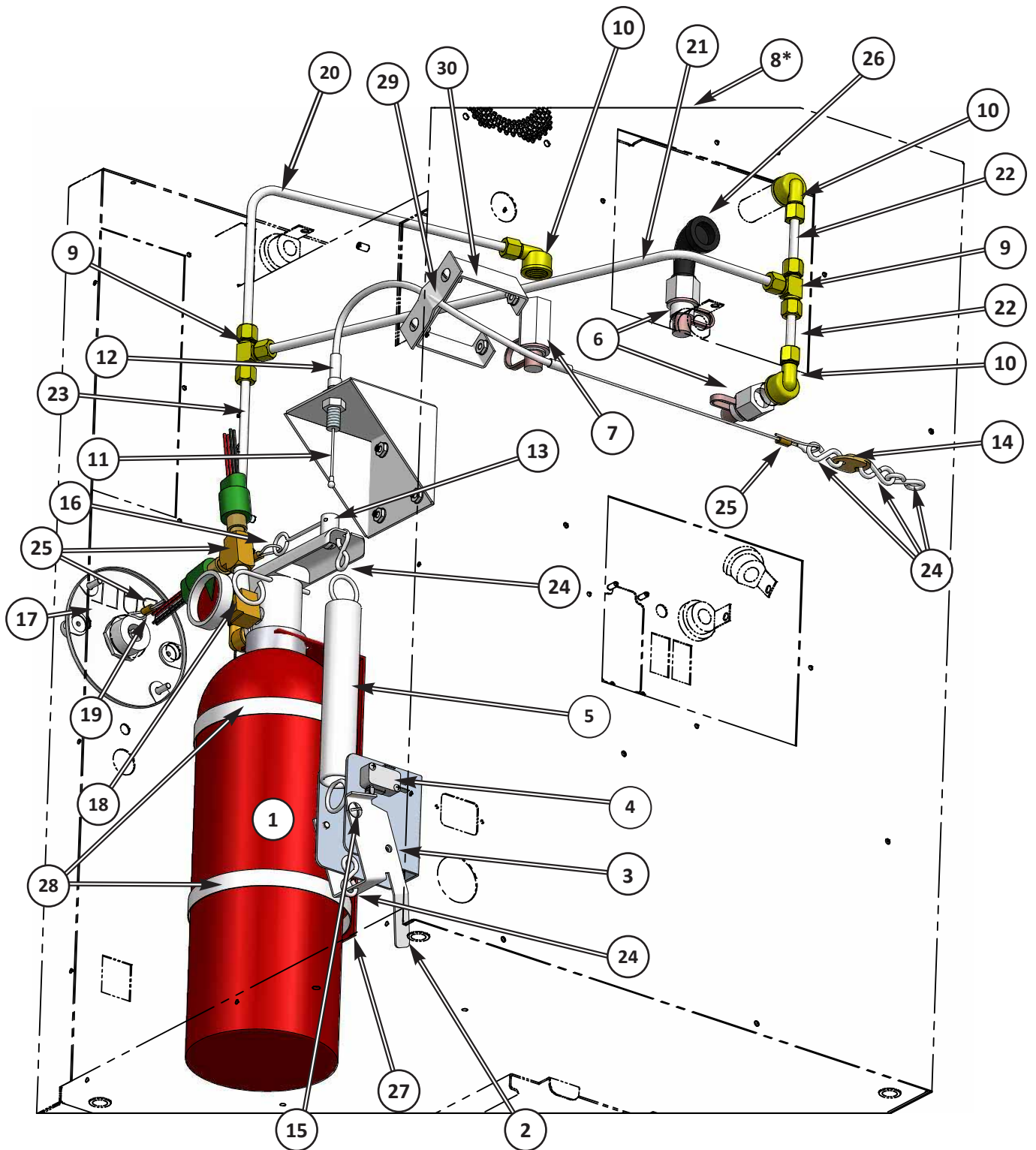

\*Hidden

## 7.7 Fire Extinguishing System

ITEM	PART NO.	QTY	DESCRIPTION
1	94311	1	TANK ASSEMBLY, COMPLETE (w/CABLE COUPLING)
2	92557	1	COCKING LEVER
3	10675	1	COCKING LEVER SET SCREW
4	20545	1	MICRO-SWITCH, SNAP-ACTION, SPDT, 250V, INTERLOCK
5	41005	1	TENSION SPRING
6	41196	2	NOZZLE, 1/2-FLOW, PLENUM
7	41195	1	NOZZLE, 2-FLOW, COOKING CHAMBER
8*	41115	1	FIRE DAMPER, 10 X 10
9	41095	2	FITTING, TEE, 1/4 TUBE, COMPRESSION
10	41096	3	FITTING, 90-ELBOW, 1/4 TUBE - 3/8 NPT
11	41099	1	CABLE ASSEMBLY, 1/16 SS, BALL w/SHANK
12	41180	1	CABLE CASING ASSEMBLY, FUSIBLE LINK
13	PART OF 94311	1	LINK CABLE COUPLING
14	41377	1	FUSIBLE LINK, MODEL-A, 280F
15	41051	2	BUSHING, 0.192" ID, 5/16" OD X 1/8" (SCREW 10-32 X 1/4" TRUSS HD, SLOT, SS)
16	94449	1	RELEASE PIN, MANUAL ACTIVATION
17	46300	1	MANUAL ACTIVATION STATION
18	PART OF 94311	1	SAFETY RING PIN (PREVENTS ACCIDENTAL DISCHARGE, REMOVE FOR USE)
19	20134	1	WIRE ROPE, 1/16", STAINLESS STEEL (MANUAL PULL)
20	94531	1	TUBE, FORMED, 12.93", FIRE SYSTEM, POT
21	94532	1	TUBE, FORMED, 17.42", FIRE SYSTEM, FILTER CHAMBER
22	94560	2	TUBE, STRAIGHT, 1.99", FIRE SYSTEM, PLENUM NOZZLES
23	94530	1	TUBE, STRAIGHT, 7.95", FIRE SYSTEM, TANK
24	41053	5	S-HOOK, 1/8", STAINLESS STEEL
25	46350	3	SLEEVE, OVAL, BRASS
26	42050	1	ELBOW, STREET, 3/8 X 90-DEG, BLACK PIPE
27	94790	1	TANK BRACKET, TRIMMED
28	40815	2	CLAMP, WORM GEAR, 1/2" X 39.5"
29	92930	1	CABLE STRAP
30	95385	1	CABLE GUIDE BRACKET

\*Hidden



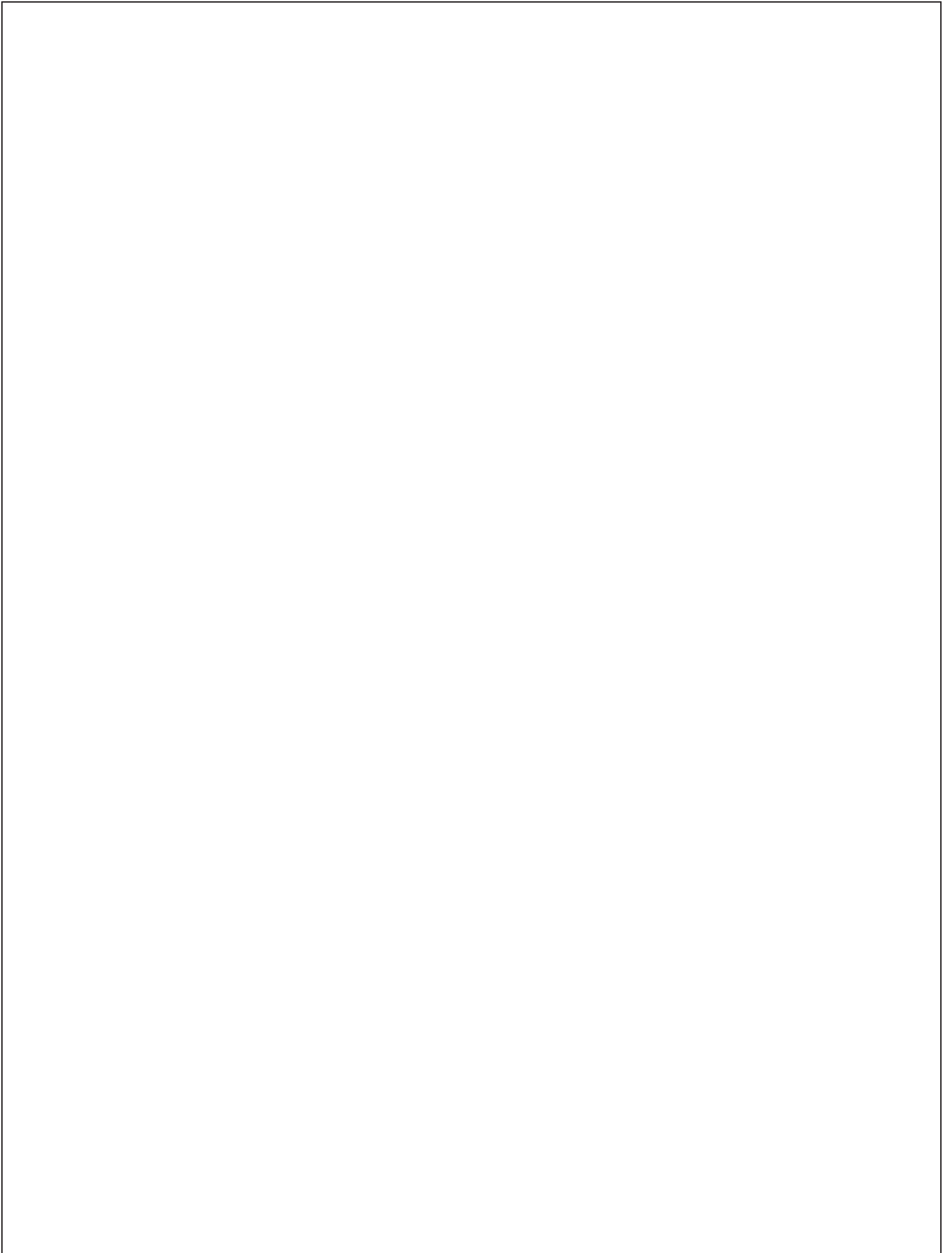



**GILES Food Service Equipment**  
**ISO 9001-2015 Certified**

2750 Gunter Park Drive West • Montgomery, AL 36109 USA  
Phone 334.272.1457 • Fax 334.239.4117 • Phone Toll Free 800.554.4537  
Website: [www.gfse.com](http://www.gfse.com) • Email: [services@gfse.com](mailto:services@gfse.com)

67314  
REV-A  
ECO3576  
01/26/2026  
PRINTED IN USA