

Operations & Service Manual



WOG-MP &
WOG-MP-VH
(Mechanical Controls)



Model: WOG-MP Mechanical Controls



Models: WOG-MP-VH Mechanical Controls



Giles Enterprises, Inc.

An ISO9001 Registered Company

2750 Gunter Park Drive West • Montgomery, AL 36109 USA

Fax: (334) 272-3561 • Internet: www.gilesent.com

Service Hotline (Toll Free): 1-800-554-4537 (USA & Canada Only)

Form No. 60198 (Release date: 4/98)(Revision date: 07/31/09)(Rev D)



LIMITED WARRANTY

- Subject to the terms and conditions of this Limited Warranty as herein stated, all Giles Enterprises, Inc., Foodservice Equipment and parts purchased new from an authorized Giles Enterprises, Inc., representative are warranted as to defects in material or workmanship for a period of 12 months from the date of installation, provided, however, that with regard to labor costs in connection with this warranty, see below. All installations must be made by a qualified installing agency in accordance with all applicable codes and/or regulations in the jurisdiction in which installed. Limited warranty coverage is extended to the original owner only and is void if the unit is resold.
- During the Limited Warranty period, Giles Enterprises, Inc. will replace or recondition, at its factory, any part or parts of this unit which Giles Enterprises, Inc. inspectors judge defective, provided the unit has been subjected to normal usage, properly installed, operated and serviced. This Limited Warranty does not cover cosmetic damage, and damage due to acts of God, accident, misuse, alteration, negligence, abuse of the Giles Foodservice Equipment or the use of unorthodox repair methods. All parts replaced under this Limited Warranty carry only the unexpired term of this Limited Warranty. Limited Warranty service may be furnished only by an authorized Giles Enterprises, Inc., representative.
- If Limited Warranty service is requested, Giles Enterprises, Inc., will send factory-authorized service representatives to repair, recondition, replace or inspect units of its manufacture with such labor being rendered without cost to owner for ninety (90) days from the date of installation. Otherwise, service, including labor and transportation charges or other expenses, in connection with the removal or installation of any part or parts supplied under this Limited Warranty, are specified on the original sales contract between the purchaser and the authorized Giles Enterprises, Inc., representative.
- Giles Enterprises, Inc. reserves the right to change or improve its equipment and parts in any way without obligation to alter such equipment or parts previously manufactured.
- Giles Enterprises, Inc. makes no further warranties, express or implied including implied warranties of merchantability or fitness for a particular purpose, and has no other obligation or liability not specifically stated herein.
- Repair or replacement as provided under this limited warranty is the exclusive remedy. Giles Enterprises, Inc., shall not be liable for any incidental or consequential damages for breach of any express or implied warranty on this product, except to the extent prohibited by applicable law. Any implied warranty of merchantability or fitness for a particular purpose on this product is limited in duration to the duration of this limited warranty.
- Used Giles Enterprises, Inc., Foodservice Equipment or parts or Giles Enterprises, Inc., Foodservice Equipment or parts not purchased from an authorized Giles Enterprises, Inc., representative, carry no warranties, express or implied.

Safety	vii
Safety Overview	vii
Specific Safety Precautions	viii
1. Introduction	1
1-01. Construction	1
1-02. Standard Features	1
1-03. Optional Ventless Hood Features	1
1-04. Specifications	2
1-04.01. Overall Dimensions for WOG-MP	2
1-04.02. Overall Dimensions for WOG-MP-VH	3
1-04.03. Regulatory Listings	4
1-04.04. Basket Size (2 Baskets included)	4
1-04.05. Cooking Capacity	4
1-04.06. Unit Weights	4
2. Installation	5
2-01. Location	5
2-02. Unpacking	6
2-03. Electrical Requirements	7
2-04. Electrical Connections	8
2-04.01. Routing conduit	9
2-05. Ventilation of Non-Ventless Fryer	9
2-06. Ventless Hood Clearances	10
2-07. Ventless Hood Fire Suppression System	10
2-08. Fusible Link and Gas Cartridge Locations	10
2-09. Fire Extinguisher Nozzle and Tank Locations	11
3. Overview	13
3-01. Cooking Vat	14
3-02. Control Panel (Manual Controls)	16
3-03. Lower Cabinet Area	18
3-04. Filter Pan Assembly	20
3-05. Ventless Hood (WOG-MP-VH)	22
3-06. Accessories (Included)	24
3-07. Accessories (Not Included)	26
4. Unit Preparation	29
4-01. Settings before testing unit	29
4-02. Power Test	30
4-03. Heating Element Test	30
4-04. Filter Pump Test	31
4-05. Perform Boil Out Procedure	31
4-06. Clean Filter Pan	31

5. Fryer Operation 33

5-01. Cooking Procedure 34

5-02. Filtering Liquid Shortening 38

5-03. Removal of Liquid Shortening 40

5-04. Normal Shut-Down 43

5-05. Emergency Shut-Down 43

6. Cleaning 45

6-01. Boil-Out Procedure (Cleaning the Cooking Vat) 45

6-02. Cleaning the Filter Pan and replacing Filter Paper after Boil Out 48

6-03. Cleaning the Filter Pan and replacing Filter Paper daily 49

7. Ventless Hood 51

7-01. Hood Operation 51

7-02. Filters 51

7-02.01. Ventless Hood Filter Table 51

7-02.02. Baffle Filter Removal. 52

7-02.03. Baffle Filter Installation 53

7-02.04. Baffle Filter Missing 54

7-02.05. Baffle Filter Cleaning. 54

7-02.06. EAC Filter Removal 54

7-02.07. EAC Filter Installation 55

7-02.08. EAC Filter Status. 55

7-02.09. EAC Filter Cleaning 56

7-02.10. Charcoal Filter Removal 57

7-02.11. Charcoal Filter Installation 57

7-02.12. Charcoal Filter Missing 58

7-02.13. Charcoal Filter Replacement. 58

7-02.14. Ultra Violet Lamp Cleaning 58

7-02.15. Ultra Violet Lamp Removal 59

7-02.16. Ultra Violet Lamp Installation 59

7-02.17. Hood Filter Alarm Chart 60

7-03. Maintenance 61

7-03.01. Monthly Interlock Check 61

7-03.02. Quarterly Hood Cleaning 61

7-03.03. Semi-Annual Fire Suppression System Service 62

7-03.04. Annual Fire Suppression System Service. 62

7-03.05. Twelve Year Suppression System Service 62

7-03.06. Maintenance and Service Log 63

8. Troubleshooting 65

8-01. Temperature Control System 65

8-02. Oil Filtration System 68

8-03. Ulitmate Ventless System. 68



9.	Parts List	69
9-01.	Parts Ordering and Service Information	69
9-02.	Control Panel & Front Header	70
9-03.	Front Lower Cabinet	72
9-04.	Rear Lower Cabinet	74
9-05.	Cooking Vat	76
9-06.	Filter Pan	78
9-07.	Front Ventless Hood	80
9-08.	Rear Ventless Hood	82



Notes:

Safety

Safety Overview

The instructions contained in this manual have been prepared to aid you in learning the proper procedures for installing and servicing your unit.

Throughout this manual, safety precautions are identified through the use of the safety alert symbol and three signal words: **DANGER**, **WARNING**, and **CAUTION**. All safety alert information precedes the step(s) to which they apply. Suggested, recommended, or other noteworthy information is identified through the use of **NOTES**. Additionally, certain words are used to indicate a specific meaning or to add emphasis.

The following words are used as indicated throughout the manual:

Shall: understood to be mandatory.

Should: understood to be advisory.

May: understood to be permissive.

Will: indicates a future event/condition to occur.

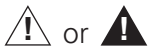

(Safety Alert Symbol)

Used in conjunction with signal words (**DANGER**, **WARNING**, or **CAUTION**) to alert you of potential personal injury hazards, immediately preceding precautionary measures that pertain to subsequent step(s). Obey all safety messages that follow this symbol to avoid possible injury or death. Failure to adhere to safety precautions identified by the safety alert symbol may also void the warranty.

DANGER

- Indicates an imminently hazardous situation which, if not avoided, will result in death or serious injury. Use of this is limited to the most extreme situations.

WARNING

- Indicates a potentially hazardous situation which, if not avoided, could result in death or serious injury.

CAUTION

- Indicates a potentially hazardous situation which, if not avoided, may result in minor or moderate injury. Also used to alert against unsafe practices.

CAUTION

- When used without the safety alert symbol, **CAUTION** indicates a potentially hazardous situation which, if not avoided, may result in equipment/property damage, and void the warranty.

NOTE:

- Identifies suggested, recommended, or other noteworthy information.

Specific Safety Precautions

For your safety, please observe the following precautions when operating or servicing your Giles equipment, Model WOG-MP and WOG-MP-VH. Read the following important safety information to avoid personal injury and/or damage to the equipment.

DANGER

- Turn off the unit and unplug the power cord before cleaning or performing maintenance.
- **DO NOT** hose down the WOG-MP or WOG-MP-VH interior or exterior with water.
- Failure to comply with these **DANGER** notices will result in death or serious injury, equipment/property damage, and void the warranty.

WARNING

- Consult a qualified electrician to ensure that:
 - all electrical specifications and codes are met.
 - circuit breakers and wiring are of sufficient rating and gauge.
- The WOG-MP and WOG-MP-VH must be properly grounded and all electrical specifications must be met during installation.
- Improper installation, adjustment, alteration, service or maintenance could result in death or serious injury, equipment/property damage, and void the warranty.
- **DO NOT** use or store gasoline or other flammable liquids or vapors in the vicinity of this or any other appliance!
- Failure to comply with **WARNING** notices could result in death or serious injury and equipment/property damage and void the warranty.

WARNING

- Internal ultraviolet radiation source.
- Keep protective barrier in place.
- Replace all removable parts after servicing.
- An interlock is provided to reduce exposure to excessive ultraviolet radiation. **Do Not** defeat the purpose of the interlock.

CAUTION

- The WOG-MP and WOG-MP-VH must remain in the upright (vertical) position.
- Exercise care when removing the wooden crate from around the unit.
- **DO NOT** operate the WOG-MP or WOG-MP-VH unless you fully understand the components and their intended function (see Section 3).
- The WOG-MP and WOG-MP-VH and its parts will become HOT!
Temperatures inside the unit may exceed 150°F (65.5°C).
Exercise caution when operating, loading/unloading food, cleaning or servicing.
Wearing of thermal oven mitts is recommended.
- Failure to comply with **CAUTION** notices may result in minor or moderate injury, equipment/property damage, and void the warranty.

CAUTION

- Food products must be maintained at a temperature of 150°F (65.5°C) minimum or in accordance with local or state health regulations.
- **The unit must be adequately and properly grounded. Improper grounding may result in electrical shock. Always refer to your local electrical code to ensure proper grounding of this or any other electrical equipment. Always consult with an electrician or other qualified service person to ensure breakers and wiring are of sufficient rating and gauge for the equipment being operated.**
- Units are available from the factory wired for various voltages, phases and hertz. Check the rating plate on the rear of the unit to determine the correct power supply.
- Ensure the unit is positioned in a secure, safe location with the casters in the locked position.
- Consult an electrician to ensure all electrical specifications have been met and the unit is properly grounded. The wiring diagrams contained in this manual should aid your electrician in the installation of your fryer.
- Due to the high temperature of shortening during cooking, it is extremely important that the user exercise caution when operating this unit in order to avoid personal injury.
- Before attempting to operate the unit, refer to Section 3 to familiarize yourself with the various control functions. Once you have read and fully understand Section 3, please follow the steps below precisely in order to prevent equipment damage or malfunction.
- Be careful not to puncture the filter paper when using the brush to unclog the Drain Valve.
- Allow the unit to cool down a minimum of 15 minutes before cleaning or servicing.
- Be careful not to bend the fins or break the ionizer wires on the Electrostatic Air Cleaner (EAC) as this will prevent the EAC from working properly and shut off the power to the appliance.

CAUTION

- The electronic components of the Control Panel are impact-sensitive. Exercise care around the Control Panel to maintain proper operation.
- **DO NOT** install the unit next to combustible walls and materials. Failure to maintain safe distances may result in fire.
- During cleaning of the WOG-MP and WOG-MP-VH:
 - **DO NOT** steam clean.
 - **DO NOT** use products containing chlorine.
 - **DO NOT** use abrasive products, steel wool or scouring pads.
 - **DO NOT** use oven cleaner.
- Failure to comply with these **CAUTION** notices may result in equipment/property damage and void the warranty.
- Failure to comply may violate local health codes.
- **DO NOT** Modify, Alter or Add Attachments to This Equipment!
- **Do Not Flambe** under the hood.
- Exercise special consideration when there are other open flued appliances in the same room to prevent backsuction of flue gases.

NOTE:

- If the shipping crate is damaged upon receipt, immediately inspect the WOG-MP or WOG-MP-VH and notify the carrier of any damage to the unit.
- To aid the electrician, an electrical wiring diagram is contained in this manual. Refer to the wiring diagram during installation or servicing.
- Comply with all appropriate state and/or local health regulations regarding the cleaning and sanitation of equipment.
- The decibel level of the hood on the WOG-MP-VH when operating, is approximately 65 dB's.
- Never attempt to clean the Charcoal Filter.
- The appliance and plenum nozzles have been factory installed in the proper operating position. **DO NOT MOVE OR ADJUST THESE NOZZLES.**

⚠ WARNING

- Use of old oil will have a reduced flash point and be more prone to surge boiling.
- Surge boiling may be caused by over-wet food and too much oil in vat. Do not overfill vat.

1. Introduction

Congratulations on the purchase of your new Giles equipment, Model WOG-MP or WOG-MP-VH, manufactured by Giles Enterprises, Inc., Montgomery, Alabama (USA), hereafter referred to as "Giles". Every unit is thoroughly inspected and tested prior to shipment. Proper care and maintenance will ensure years of trouble-free service.

To help protect your investment in this state-of-the-art cooking equipment, we recommend you take a few moments to familiarize yourself with the installation, cleaning and maintenance procedures contained in this manual. Adherence to these recommended procedures minimizes the potential for costly "Down-Time" and equipment repairs. Please retain this manual for future reference.

1-01. Construction

Model WOG-MP and WOG-MP-VH, is constructed of various stainless steel.

1-02. Standard Features

Temperature Control -used to control the temperature of the cooking oil, adjustable up to 375°F (191°C).

Dual Cooking Timers -used to indicate the end of a cooking cycle, adjustable up to 30 minutes.

Oil Filtration System -used to extend the life of cooking oil.

Ventless Hood Unit Only

Ventless Hood -used to remove particulates from the air without using a vent to the outside.

Extinguishing System -built into the hood to extinguish an accidental fire from the cooking oil.

1-03. Optional Ventless Hood Features

Ultimate Ventless Option -Ultra Violet light in conjunction with Giles patented air filtration system improves emission cleaning and odor control as well as keeping the unit free from grease build-up

Interlocking Start System (ILS) -Interlocking Start System (ILS) -This system will cause the Hood and the Fryer to shut down when the hood filters need to be cleaned or are not properly installed. ILS is required by some cities and/or states. Please check with your local code officials to see if this system is required.

1-04. Specifications

1-04.01. Overall Dimensions for WOG-MP

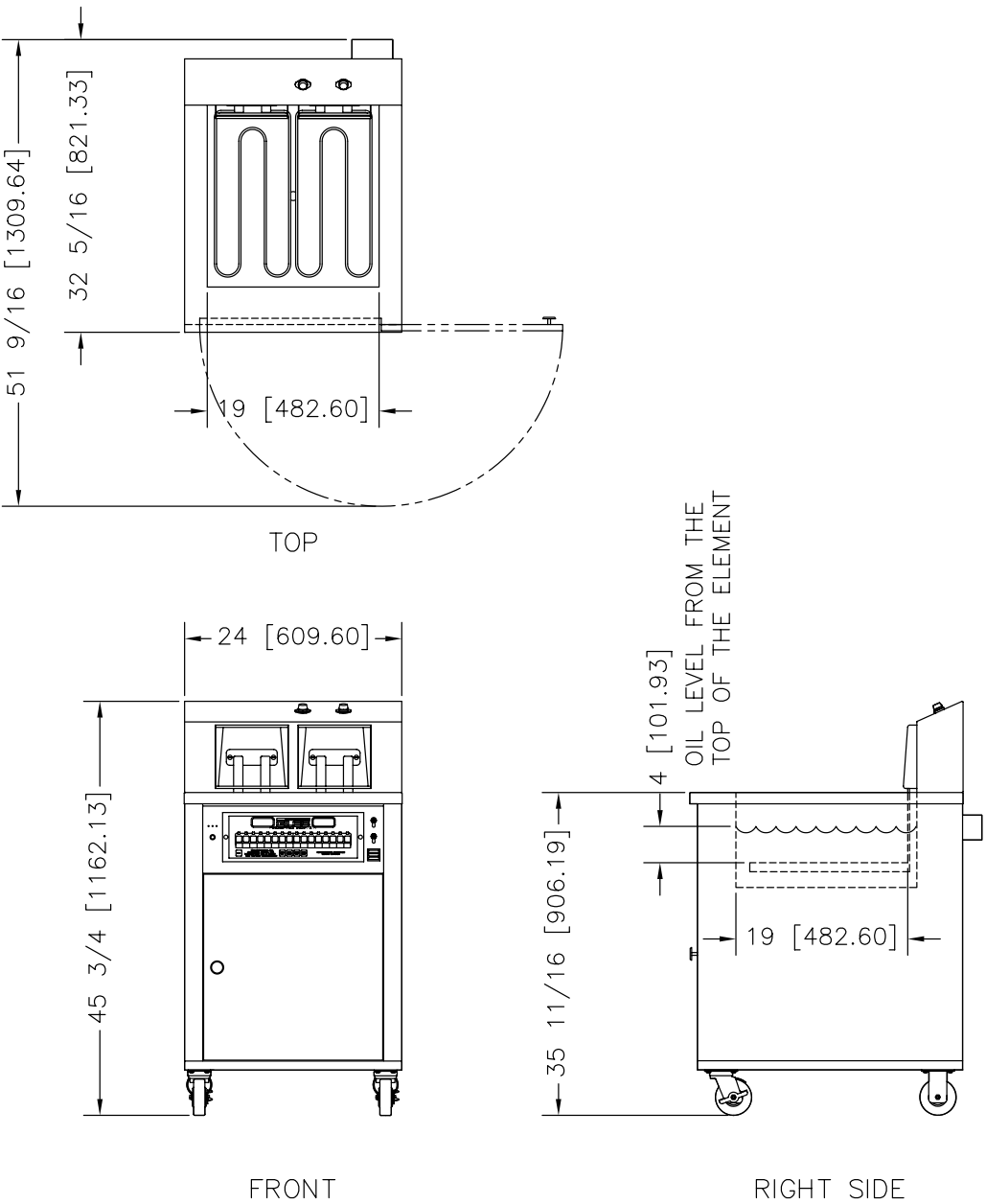

| Inches [Millimeters]

1-04.02. Overall Dimensions for WOG-MP-VH

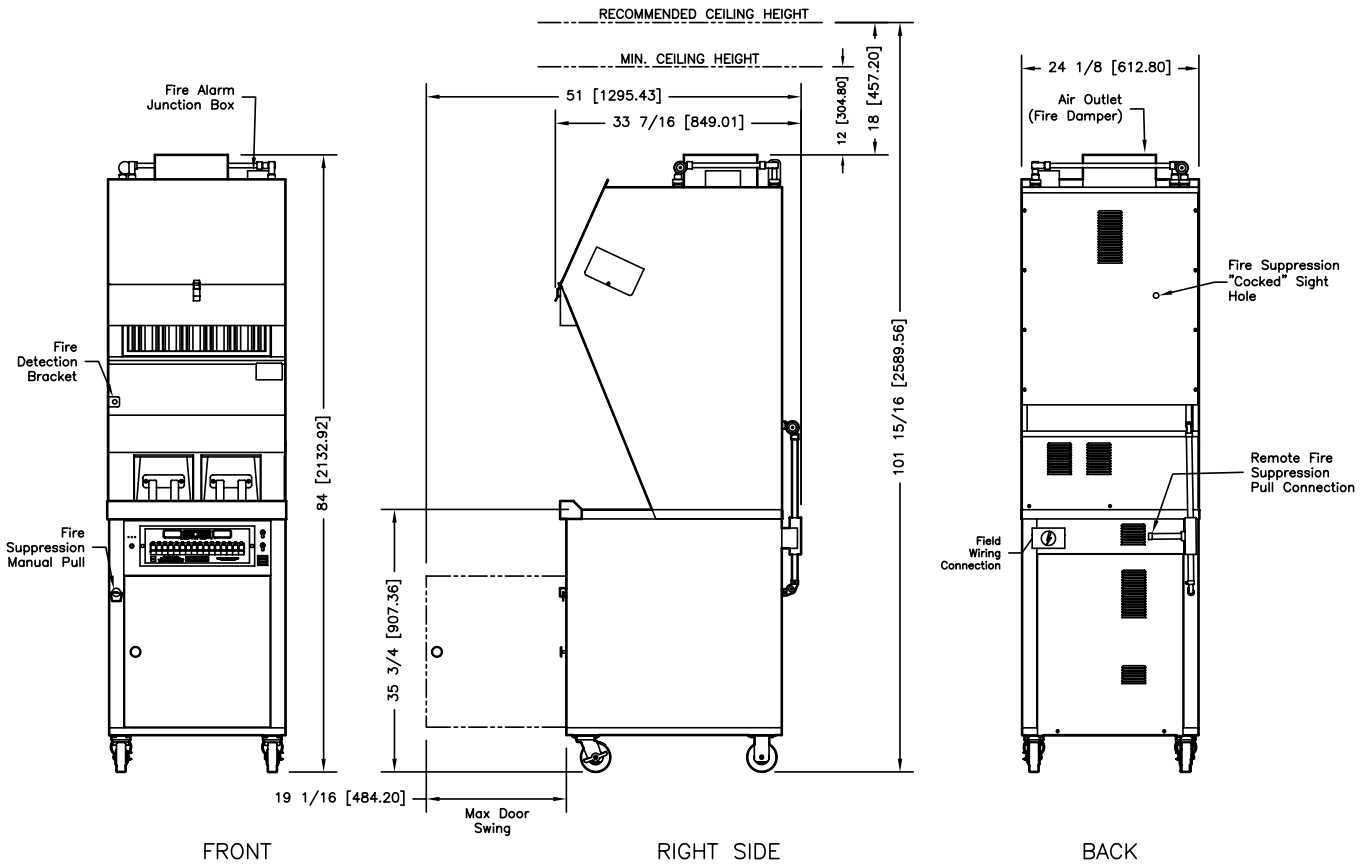

Inches [Millimeters]

1-04.03. Regulatory Listings

UL (US and Canada)
NSF
CE

1-04.04. Basket Size (2 Baskets included)

Model	Basket Size						Volume	
	Length		Width		Height		cubic inch	cubic meter
	in	mm	in	mm	in	mm		
WOG-MP	15.375	390.5	7.25	184.1	6.0	152.4	668.81	0.0109
WOG-MP-VH	15.375	390.5	7.25	184.1	6.0	152.4	668.81	0.0109

1-04.05. Cooking Capacity

Model	Liquid Shortening Capacity			
	lb	kg	gallon	liter
WOG-MP	70	31.7	9.1	34.4
WOG-MP-VH	70	31.7	9.1	34.4

1-04.06. Unit Weights

Model	Weights			
	Crated		Uncrated	
	lb	kg	lb	kg
WOG-MP	335	152	235	107
WOG-MP-VH	602	273	475	215

2. Installation

This section provides a summary of the procedures necessary for proper installation of your new Giles equipment, Model WOG-MP or WOG-MP-VH. To prevent personal injury or equipment damage, please ensure the following steps are taken.

2-01. Location

NOTE:

- The decibel level of the hood on the WOG-MP-VH when operating is approximately 65 dB's.

CAUTION

- **DO NOT MODIFY, ALTER OR ADD ANY ATTACHMENTS TO THIS EQUIPMENT**

1. Keep the appliance and surrounding area free and clear from combustible materials. See Section 1-03.01 and Section 1-03.02.
2. Please retain this manual for future reference.
3. Please note wiring diagrams for this unit are located on the rear of the unit. Ensure the wiring diagram corresponds with the model being operated.
4. Please ensure this unit is electrically grounded in accordance with local codes, or in the absence of local codes, with the National Electrical Code, ANSI/NFPA NO. 70-1999.
5. Please provide adequate room for servicing and proper operation of this appliance. Also, provide adequate ventilation in the operating area where necessary.
6. Always consult an electrician or other qualified individual prior to installation.
7. Ensure voltage and amperage supplied to the unit are as specified on the fryer's rating plate.
8. Make sure this unit is in a secure position and will not move. Locking casters are supplied on this unit and must be placed in the locked position during unit operation.
9. Based on local codes, room size and appliances in use, exhaust ventilation may be required for the WOG-MP-VH. This often can be accomplished by the installation of an exhaust fan in the room in which the hood is installed. To determine the requirements for your installation, supply the HVAC dealer the following information.
 - a. The WOG-MP-VH Hood exhausts between 267 to 382 cfm of air.
 - b. The average temperature of the air being exhausted from the Hood, after four (4) hours of continuous frying, is approximately 90°F (32°C).
10. This appliance is to be installed, used and maintained in accordance with the Standard for Ventilation Control, and Fire Protection of Commercial Cooking Operations, NFPA 96.

The above steps will help to ensure safe and proper installation of your fryer. If you have any questions concerning these procedures, contact your local Giles representative or other qualified service person.

2-02. Unpacking

Your Giles Fryer may arrive enclosed by a wooden crate. The Fryer is secured to a wooden platform by means of high-tensile strength strapping.

CAUTION

- The Ventless Hood must remain in the upright (vertical) position.
- Exercise care when lifting or moving the unit.
- Exercise care when removing the wooden crate from around the unit.
- Failure to comply with these **CAUTION** notices may result in minor or moderate injury, equipment/property damage, and void the warranty.

NOTE:

- If crate is damaged, immediately inspect the unit and notify the carrier of any damage to the unit.
1. Carefully cut and remove the plastic shipping wrap and the strapping mentioned above.
 2. Use pliers to loosen wire hooks which secure the wooden crate around the fryer. Remove the wooden crate.
 3. Carefully remove the fryer from the shipping platform. Your new fryer is extremely heavy, see Weights 1-03.06, great care should be taken in lifting or moving the unit to prevent personal injury or equipment damage.

2-03. Electrical Requirements

⚠ CAUTION

- Fryers must be adequately and properly grounded. Improper grounding may result in electrical shock. Always refer to your local electrical code to ensure proper grounding of this or any other electrical equipment. Always consult with an electrician or other qualified service person to ensure breakers and wiring are of sufficient rating and gauge for the equipment being operated.
- Giles Electric Fryers are available from the factory in the voltage and phase listed below. Check the rating plate on the front of the fryer to determine the correct power supply.

Recommend Circuit Breaker

Model	Voltage	Phase	Hz	Ampage	Breaker Size Ampage
WOG-MP	208	1	60	96	150
WOG-MP	240	1	60	83	150
WOG-MP	208	3	60	58	80
WOG-MP	240	3	60	50	80
WOG-MP-VH	208	1	60	98	150
WOG-MP-VH	240	1	60	85	150
WOG-MP-VH	208	3	60	57	80
WOG-MP-VH	240	3	60	49	80
WOG-MP-VH	220	1	50	85	150
WOG-MP-VH	380	3	50	29	40

2-04. Electrical Connections

Fryer Power Connection

1. Install appropriate Circuit Breaker in Main Breaker Box. See Table 2-03.
2. Connect Flexible Conduit from Main Breaker Box to Fryer. Allow enough Conduit so Fryer can be moved from the wall for cleaning and servicing. See Figure 2-04.1.
3. Open Fryer's Service Box. See Figure 2-04.1.
4. Route appropriate size Power Wires from the Circuit Breaker to the Fryer.
5. Connect the Power Wires using the appropriate size Wire Nuts to the Fryer's Power Lead Wire located in the Service Box.
6. Reinstall Service Box Cover.

Fire Alarm Connection (Ventless Hood Model Only):

This connection will send a signal to the Facility Fire Alarm System that the Hood Fire Extinguisher System has been activated.

1. Remove Cover on Fire Alarm Tie-In Box and run appropriate size conduit and wire from the Box to the Facility Fire Alarm System. Allow enough conduit and wire so the Hood can be accessed for cleaning and servicing.
2. Make appropriate connections.
3. Reinstall Fire Alarm Tie-In Box Cover.

2-04.01. Routing conduit

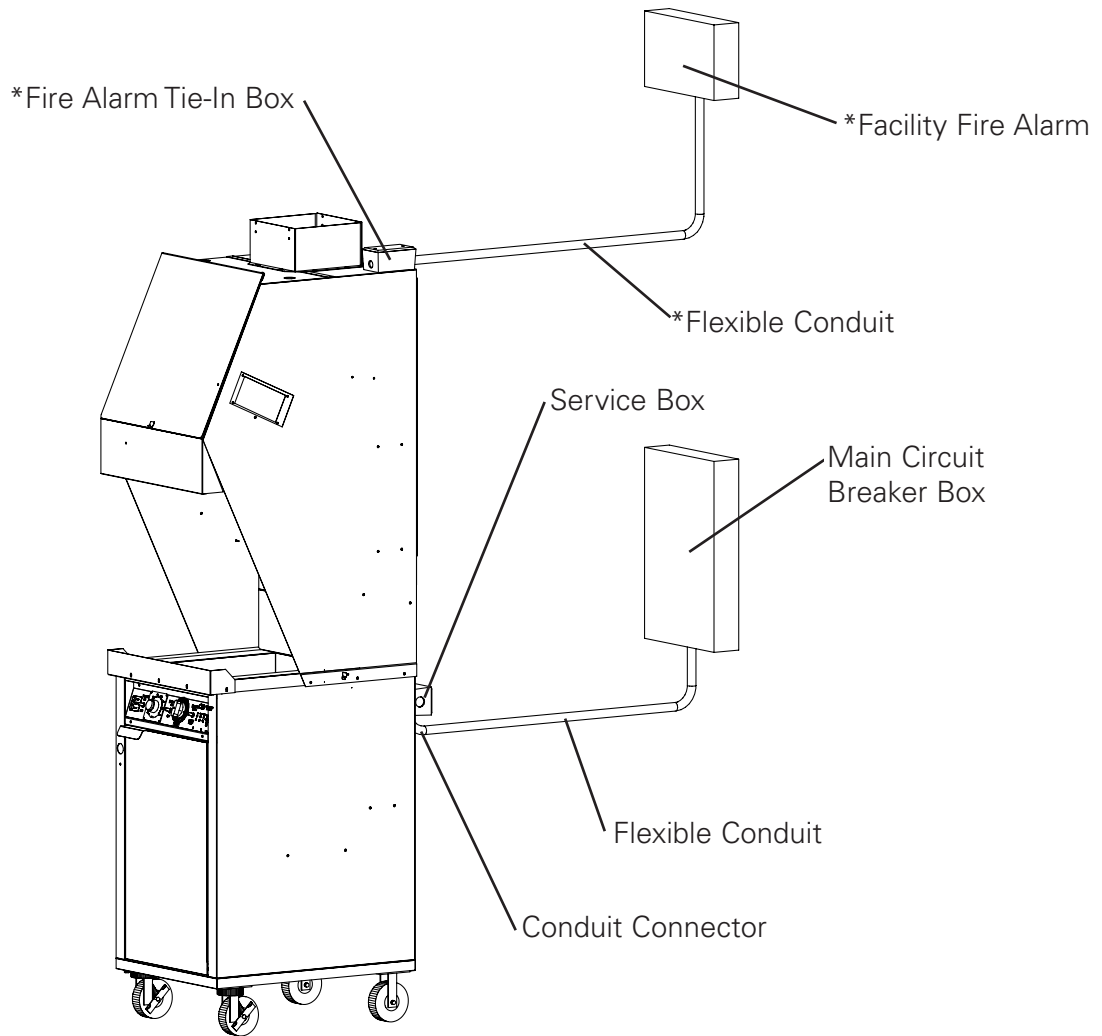

* - Ventless Hood Model Only

2-05. Ventilation of Non-Ventless Fryer

NOTE:

- Guidelines for proper ventilation system requirements may differ from location to location. Always consult with local authorities to ensure compliance.

Consult a professional ventilation or heating and air conditioning company for assistance in designing a hood for this unit.

2-06. Ventless Hood Clearances

The WOG-MP-VH requires a minimum 12 inches [305 mm] clearance from the top of the exhaust stack to the ceiling, however 18 inches [457 mm] is recommended. This is required to allow the proper air flow through the unit. See Section 1.03.02.

2-07. Ventless Hood Fire Suppression System

The fire suppression system used in your Giles Ventless Hood Fryer is an Ansul R-102 Restaurant Fire Suppression System (Standard UL 197 Listed). **Final installation, charging and testing of the system is to be performed by an authorized Ansul distributor in accordance with the system's listing.**

The fire suppression system is designed and ULlisted to provide fire protection for cooking appliances such as fryers. It protects your units, automatically, 24 hours per day. The system contains piping, nozzles (both appliance and plenum), and conduit for routing the fusible link cable through the hood.

2-08. Fusible Link and Gas Cartridge Locations

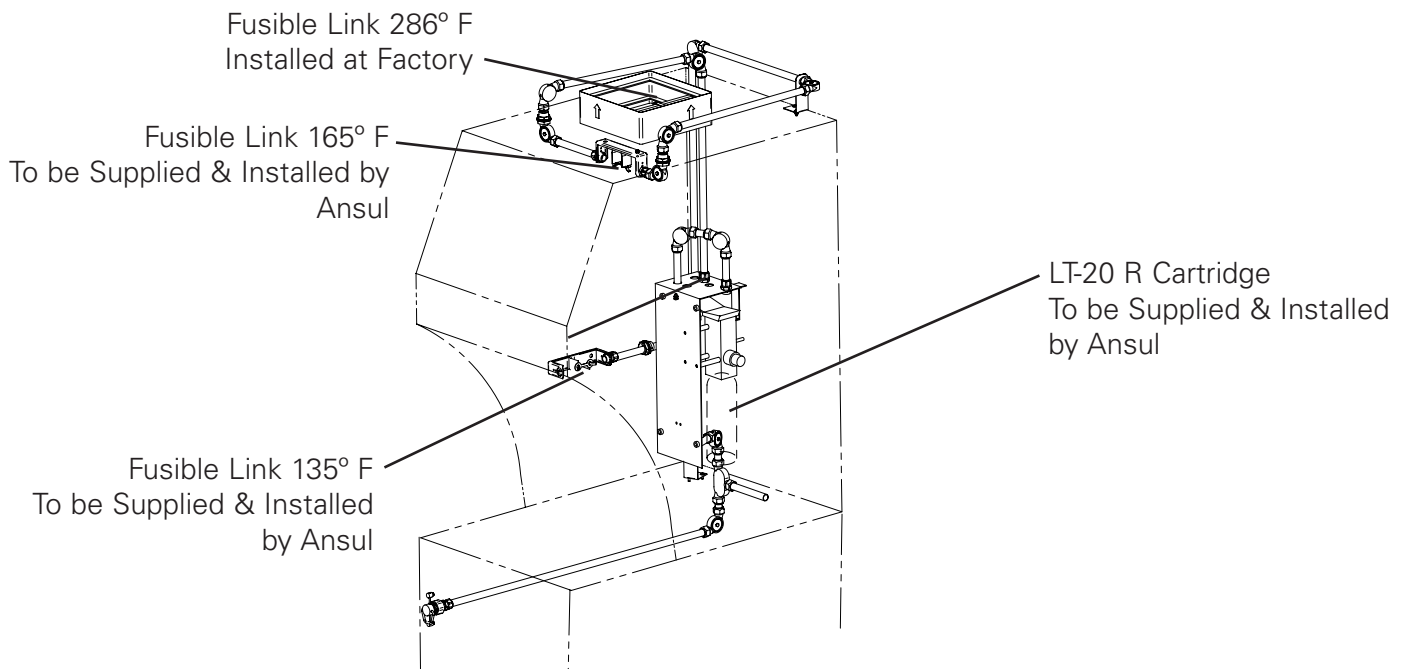

2-09. Fire Extinguisher Nozzle and Tank Locations

All nozzles have been factory installed in the proper operating position. **DO NOT MOVE OR ADJUST.**

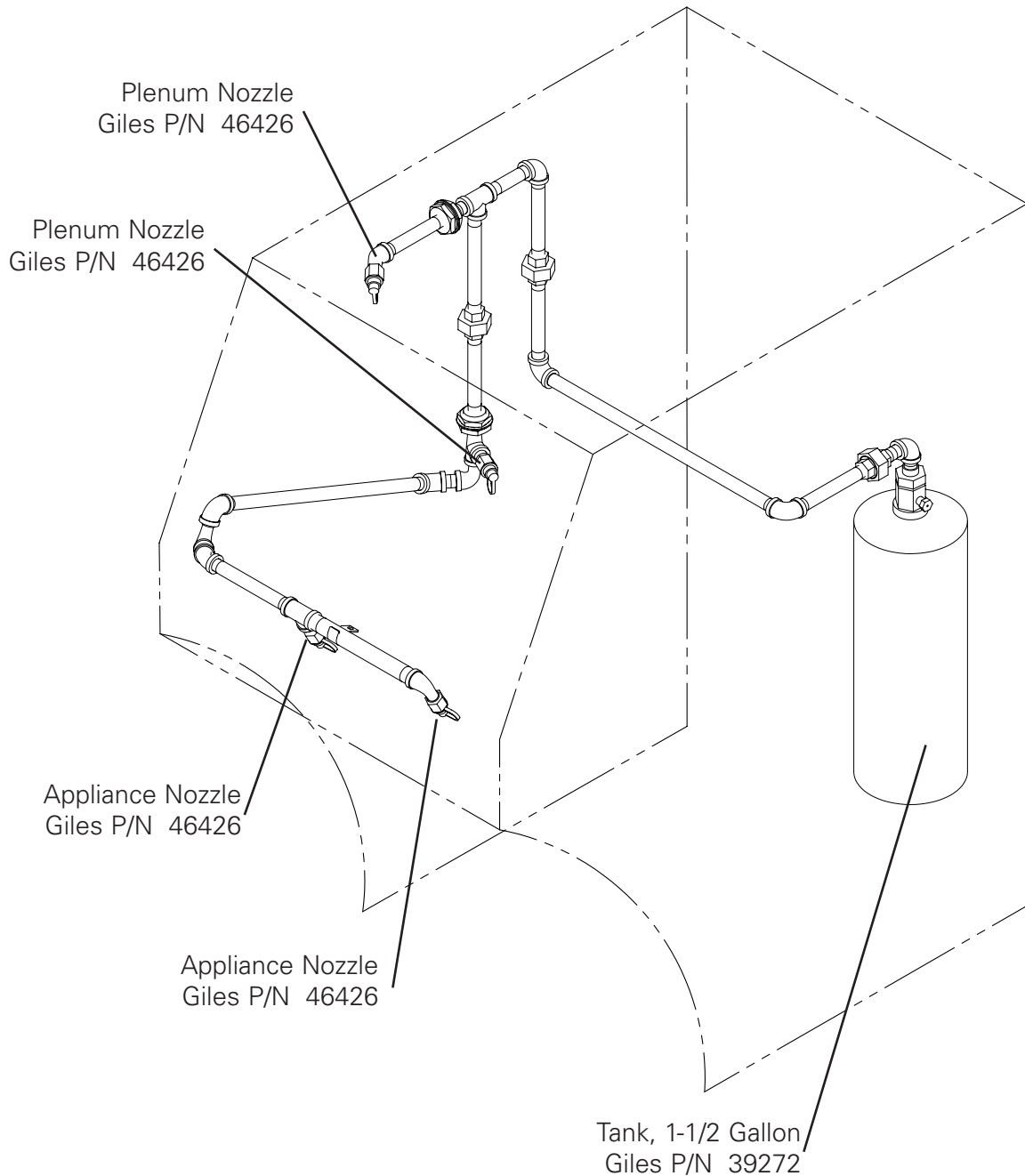



Notes:

3. Overview

The following section provides a brief overview of the components, functions, and accessories of the Giles Electric Fryer, Model WOG-MP and WOG-MP-VH. Please review this section carefully before proceeding any further.

UV Sight Window
(optional)

Ventless Hood
Figure 3-05.

Cooking Vat
Figure 3-01.

Control Panel
Figure 3-02.

Lower Cabinet
Area
Figure 3-02.

Filter Pan Assembly
Figure 3-03.

Model: WOG-MP-VH



3-01. Cooking Vat

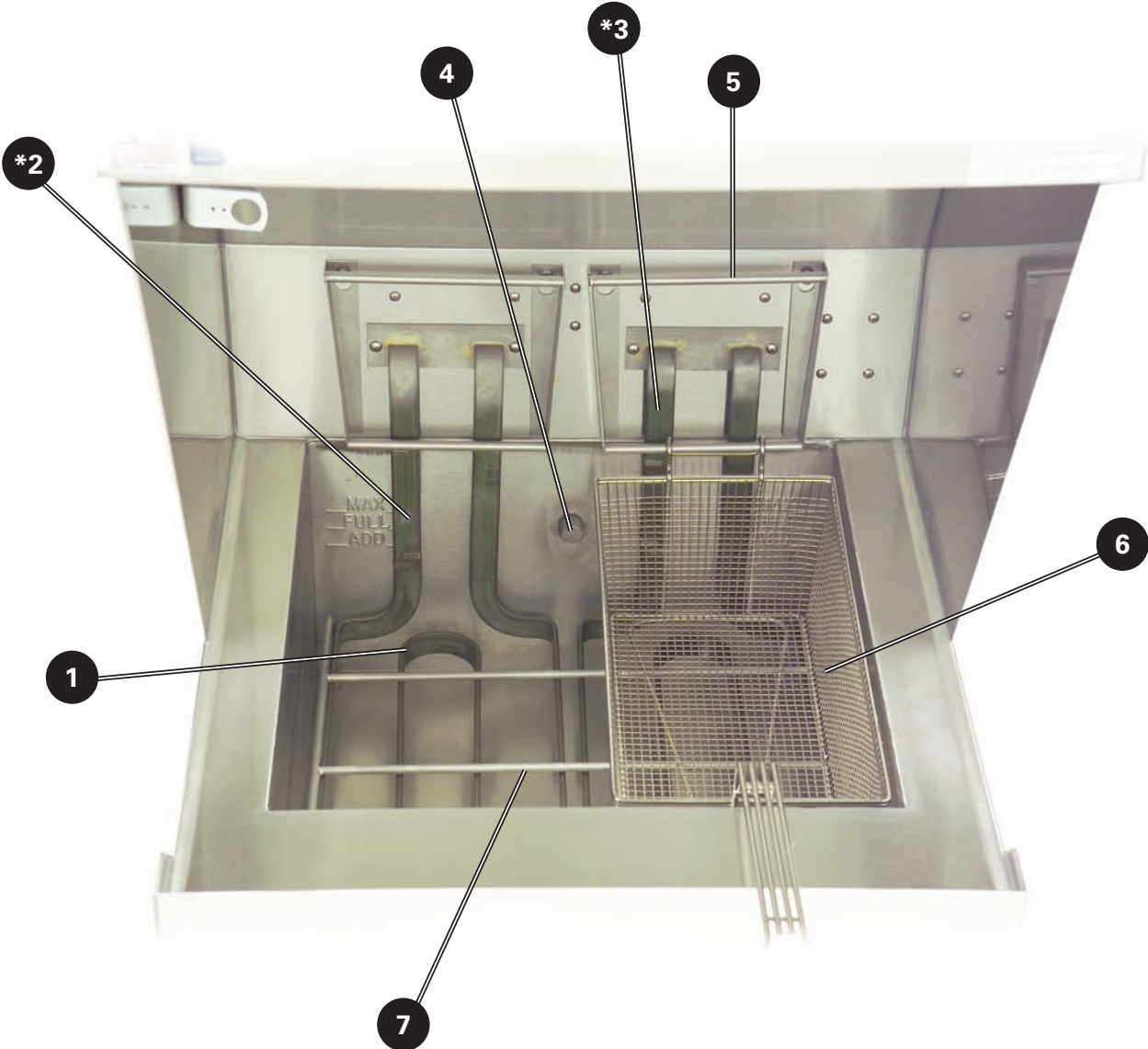

* -Not Shown

3-01. Cooking Vat		
Item	Description	Function
1	Heating Element	Used to heat the Cooking Oil.
*2	Hi-Limit Temperature Probe	Used to prevent the Cooking Oil from overheating. If this probe detects the Cooking Oil at or above 425°F, the Heating Element will shut off and the Hi-Limit Indicator Light will come on.
*3	Variable Temperature Probe	Used to detect the temperature of the Cooking Oil for the Cooking Thermostat.
4	Cooking Oil Return	Used to return the Cooking Oil from the Filter Pan to the Cooking Vat.
5	Basket Hanger	Used to hold the Cook Baskets out of the Cooking Oil for loading or draining the product.
6	Cook Basket	Used for cooking the product.
7	Basket Rack	Used to prevent the Cook Baskets from touching the Heating Element.

* -Not Shown

3-02. Control Panel (Manual Controls)

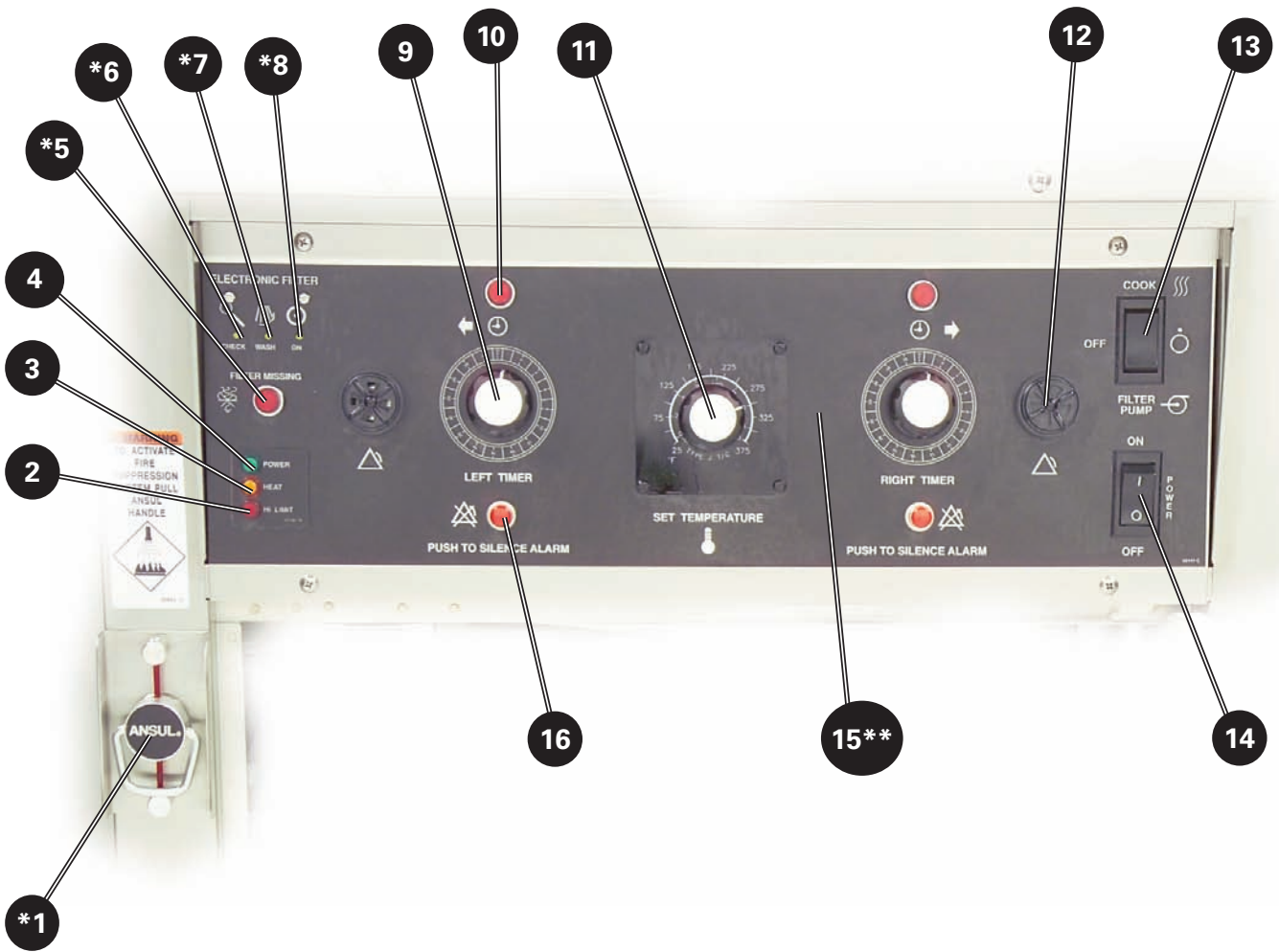

* -Used on Ventless Hood (VH) Models Only
 ** -Used on ILS Models Only, not shown

3-02 Control Panel (Manual Controls)		
Item	Description	Function
1*	Fire Extinguisher Pull Handle	Pull this handle if an accidental fire should occur in the cooking vat. This will actuate the fire suppression system.
2	High-Limit Indicator	Illuminates as a result of power being shut off to the unit's heating elements by the built-in solid-state control circuit as a safeguard against over-heating. Should this light come on during operation, refer to the Troubleshooting Section 8 of this manual. NEVER COOK IN A FRYER WHEN THE HIGH-LIMIT LIGHT IS ON!
3	Heat Indicator Light	The Orange Heat Indicator Light will be on when the unit's heating elements are operating. When the selected operating temperature is reached, the light will go off.
4	Power Indicator Light	The Green Power Light is on whenever the unit's Master Power Switch is in the "ON" position.
5*	Filter Missing	The "Filter Missing" Light is on when the Grease Baffle Filter or the Charcoal Filter are not properly positioned.
6*	EAC Status "CHECK"	The "Check" Indicator Light is on when the EAC becomes shorted. (EAC needs cleaning or repair).
7*	EAC Status "WASH"	The "Wash" Indicator Light is on when the EAC becomes excessively dirty. Do not use the wash light as a signal for routine cleaning of the EAC, doing so will significantly decrease the life of the charcoal filter. Clean the EAC daily for best performance and extended charcoal filter life.
8*	EAC Status "ON"	The "ON" Indicator Light is on when the Electronic Air Cleaner (EAC) power supply is on.
9	Cooking Timer	Used in conjunction with the Signal Switch, the Timer will activate an alarm at the end of a cooking cycle. Note: the Signal Switch must be in the ON position for an alarm to sound.
10	Timer Indicator Light	Used to indicate cooking time has expired for the left or right Cooking Timer..
11	Thermostat	Used to control the cooking oil temperature which is adjustable up to 375°F.
12	Timer Alarm	Used to indicate the end of left and/or right cooking time.
13	Selector Switch	Used to select either the "COOK," "OFF" or "FILTER" modes of operation. The unit's heating elements will only operate in the "COOK" position. The switch should be placed in the "FILTER" position to filter the shortening which will allow the pump to operate.
14	Power Switch	The Power Switch is a two-position Switch. Move the switch upward to the "ON" position for operation.
15**	Push to Start Button	After the Power Switch is in the "ON" position, push and hold down "PUSH to START" Button for 5 seconds. (ILS Only).
16	Silence Alarm Button	Used to turn off the alarm which indicates the end of a cooking time.

* -Used on Ventless Hood (VH) Models Only

** -Used on ILS Models Only, not shown

3-03. Lower Cabinet Area

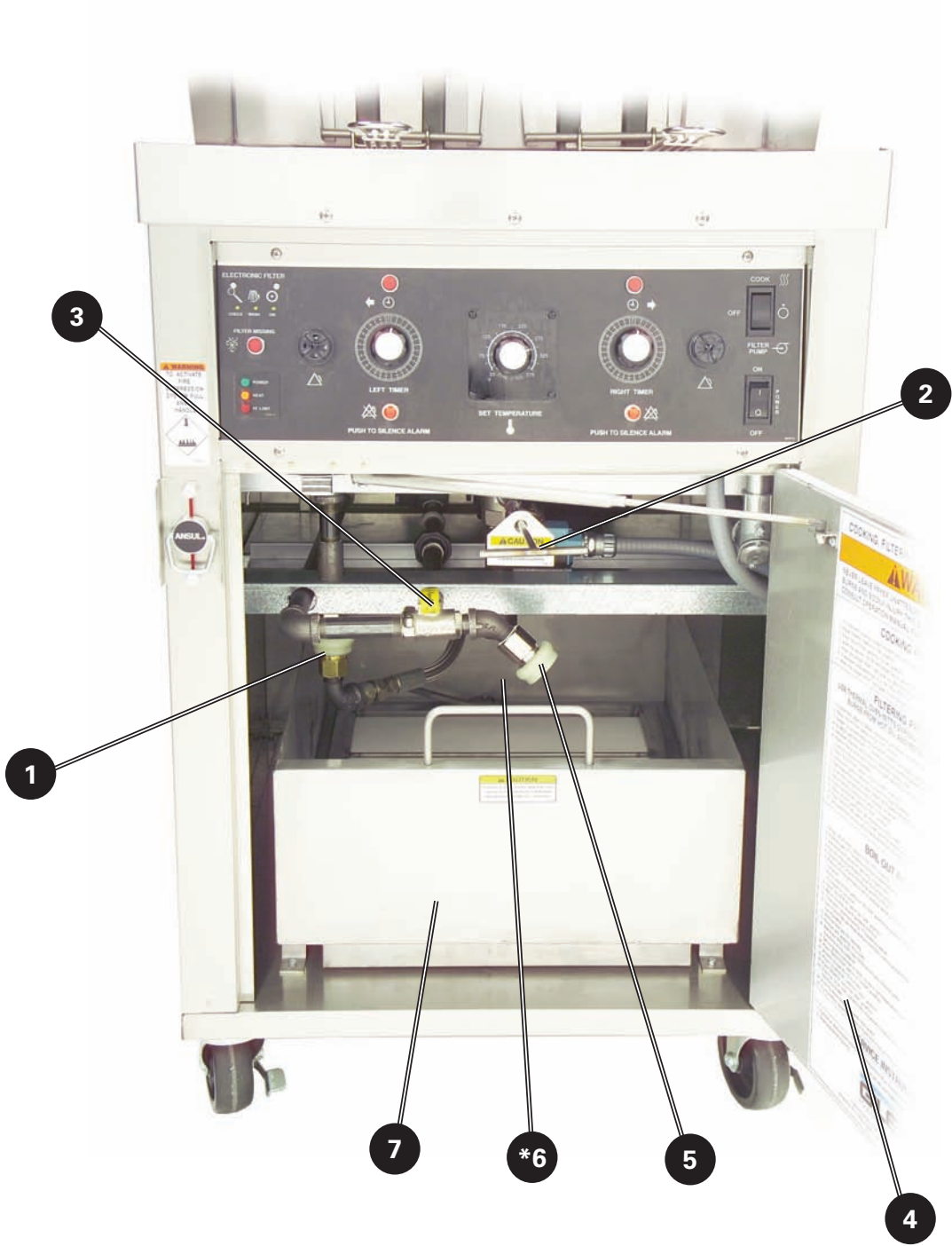

* -Not Shown



3-03. Lower Cabinet Area		
Item	Description	Function
1	Quick Disconnect for Filter Pan Hose	Used to connect the Filter Pan Quick Disconnect hose to the unit's oil filtration system.
2	Drain Valve Handle	Used to drain the cooking vat. Always ensure the valve is closed prior to adding cooking oil or boil out solution. Your fryer will not heat if this drain valve is not completely closed.
3	Diverter Valve Handle	Used to divert the cooking oil to the cooking vat or to the cooking oil discharge wand.
4	Cabinet Door	Used to access all lower cabinet functions.
5	Quick Disconnect for Oil Discharge Wand	Used in conjunction with the oil discharge wand to remove oil from the fryer.
*6	Drain Pipe Extension	Used to help prevent excessive oil splashing while draining the Fry Vat. Pipe must be removed before removing Filter Pan.
7	Filter Pan	See Section 3.04.

* -Not Shown

3-04. Filter Pan Assembly

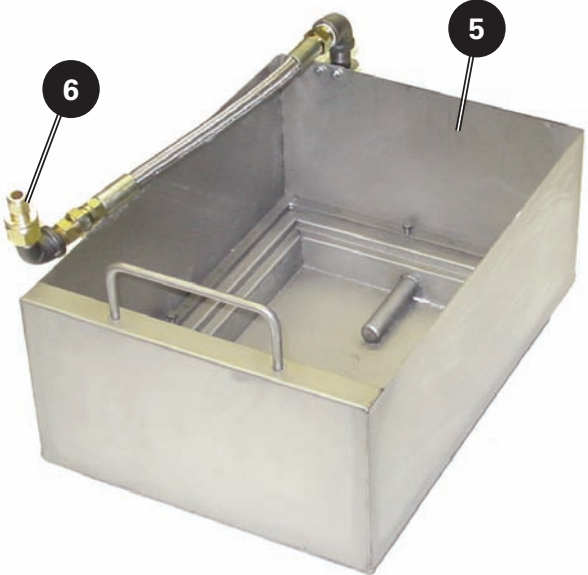
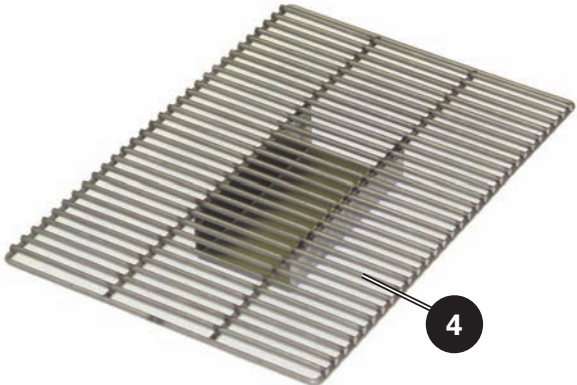



⚠ WARNING

- Never disconnect the Filter Pan from unit with Liquid Shortening in the Filter Pan.

⚠ CAUTION

- Always use Oven Mitts when working with the Filter Pan. Filter Pan parts will become very hot.

3-04. Filter Pan Assembly		
Item	Description	Function
1	Hold Down Lever (4 levers)	Used to hold down the hold down frame tightly on the filter paper.
2	Hold Down Frame	Used to hold down the filter paper tightly.
3	Filter Paper (2 sheets required)	Used to filter of sediment from the cooking oil. The system requires (2) pieces to be used.
4	Filter Pan Screen	Used to elevate the filter paper from the bottom of the filter pan to allow proper filtration.
5	Filter Pan	Used to filter cooking oil. The Filter Pan is removable for cleaning and for the changing of the filter paper.
6	Filter Pan Quick Disconnect Hose	Used to connect to the fryer's oil filtration system. The hose must be disconnected before removing the filter pan.





3-05. Ventless Hood (WOG-MP-VH)





* -Not Shown

3-05 Ventless Hood (WOG-MP-VH)		
Item	Description	Function
1*	Hood Filter Cover	Used to access the EAC and Charcoal Filters. This cover must be in place and latched for the unit to operate.
2	Charcoal Filter	This Filter helps to remove odors generated during cooking. This Filter should be replaced monthly. NEVER attempt to clean a Charcoal Filter. Keep a spare filter on hand (Giles 30248) for quick change-out when needed!
3	EAC Filter	The EAC Filter is an electrical device which removes grease vapor and smoke generated by the fryer during cooking. Power must be turned OFF to the fryer before removing the EAC for cleaning. The EAC should be cleaned daily.
4	Baffle Filter	The Baffle Filter is the first stage of the grease extraction and air-cleaning system. It is easily removed for daily cleaning. DO NOT remove the Baffle Filter while the unit is operating to prevent contact with electrical parts and to avoid electrical shock.
5	Grease Drip Cup	Used to hold excess grease from the hood. This cup should be cleaned daily or as needed.
6	Grease Drip Cup Safety Pin	Used to hold the Grease Drip Cup in place and to prevent the cup from accidentally dropping
7	Exhaust Stack	Located on top of the unit. Allow the recommended clearance of 18" or a minimum clearance of 12" between the top of the Exhaust Stack and the ceiling.
8	Ultra Violet Lamp <i>(optional)</i>	Improves emission cleaning and odor control as well as keeping the unit free from grease build-up, improving fire safety and leading to less maintenance. This lamp should be cleaned monthly and replaced annually.

* -Not Shown

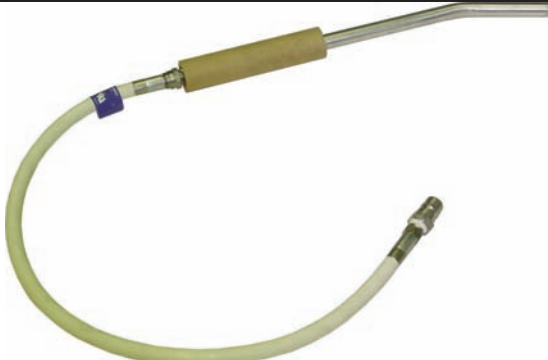
3-06. Accessories (Included)		
Part	Description/ Part Number	Function
	Kettle Drain Brush P/N 71025	Used for cleaning the Fry Pot.
	Stir Paddle P/N 77775	Used for stirring Hot Oil and Product being cooked.
	Pot Brush P/N 71100	Used for cleaning Fry Pot and Elements.
	Crumb Shovel P/N 30059	Used for removing sediment from the Filter Pan.

3-06. Accessories (Included)		
Part	Description/ Part Number	Function
	L Shaped Brush P/N 73233	Used for cleaning between elements.
	Wand Hose P/N 30051	Used for removing liquid shortening from unit. WARNING: DO NOT USE TO WASH DOWN THE COOKING VAT!!
	Soak Tank P/N 39327	Used for cleaning EAC filter.
	UV Lamp P/N 90226	Used for emission control

3-07. Accessories (Not Included)

Part	Description/ Part Number	Function
	<p>Filter Paper P/N 60819</p>	<p>Used to filter the cooking oil</p>
	<p>Filter Powder P/N 72004</p>	<p>Used to help clean the cooking oil</p>
	<p>Fryer Boil-Out P/N 72003</p>	<p>Used to help clean the fry pot.</p>

3-07. Accessories (Not Included)

Part	Description/ Part Number	Function
	<p>Giles Oil Caddy P/N 79187</p>	<p>A portable oil disposal container with a capacity of 80lbs of liquid shortening.</p> <p>Note: For use with filtered, warm oil only. No Crumbs or Debris.</p>



Notes:

4. Unit Preparation

We at Giles Enterprises, Inc. take pride in the quality of our workmanship. Every effort has been made to ensure that your unit is in good operating condition when you receive it. Each unit must pass a rigorous quality control test prior to shipment. To further ensure optimum operation of your new unit, we recommend a brief operational check-out of your new unit.

Before attempting to operate the unit, refer to Section 3 to familiarize yourself with the various control functions. Once you have read and fully understand Section 3, please follow the steps below precisely in order to prevent equipment damage or malfunction.

4-01. Settings before testing unit

Please ensure the unit is set to the following settings before proceeding.

1. Ensure the Power Switch is in the OFF **1** position.
2. Ensure the Selector Switch is in the OFF **2** position.

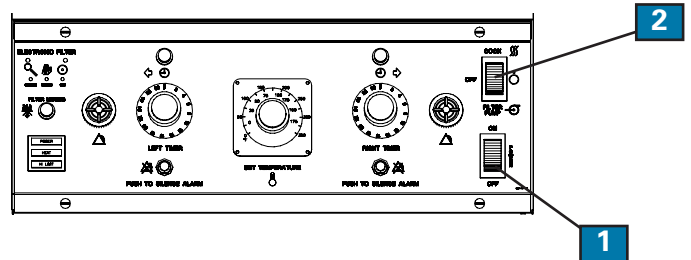

3. Open the Cabinet Door and remove the Filter Pan.
4. Ensure the Drain Valve Handle is in the CLOSED **3** horizontal position.
5. Ensure the Oil Diverter Valve is in the TO FRYER **4** position.
6. Remove Baskets.

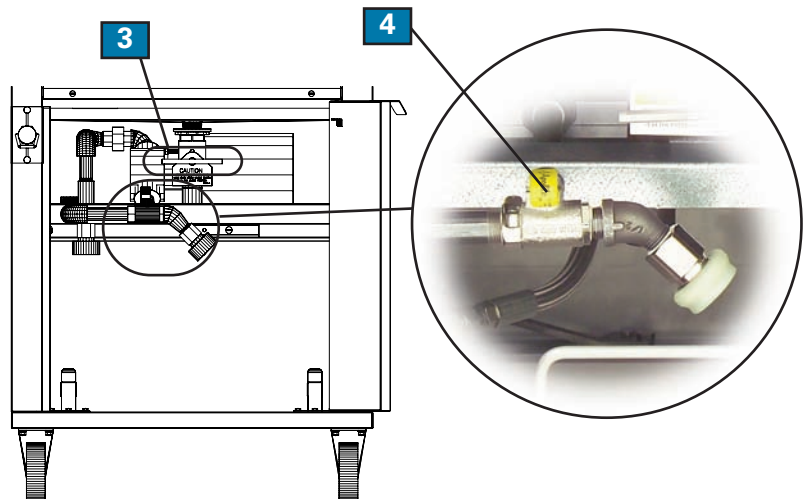

4-02. Power Test

The following test will ensure the unit has power.

1. Follow steps shown in Section 4-01.
2. Ensure the main circuit breaker powering the unit is ON.
3. Press the Power Switch to the ON **1** position. The green POWER light **2** will come on. Please proceed to Section 4-03.

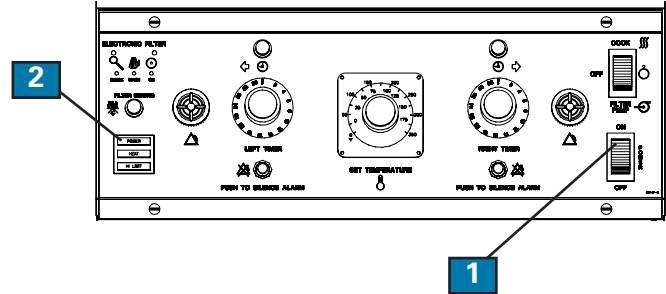

If the POWER light **2** does not come on, refer to the Troubleshooting procedure in Section 8-01.

4-03. Heating Element Test

The following test will ensure the Heating Elements are being powered.

CAUTION

- **DO NOT touch the Heating Elements. The Heating Elements are very hot and skin contact with the Heating Elements may result in severe burns.**

1. Follow steps shown in Section 4-01.
2. Ensure Power Switch is in the OFF position and the Heating Elements are cool.
3. Wipe the Heating Element **1** with a sponge wet with water.
4. Move the Power Switch to the ON **2** position.
5. Rotate the Thermostat to 375°F **3**.
6. Move the Selector Switch to the COOK **4** position. Leave in the COOK position **NO MORE THAN 10 SECONDS.**
7. Press the Selector Switch to the OFF **5** position
8. The wet element should quickly dry within 15 seconds. Proceed to Section 4-04.
If the Heating Element does not dry within 15-30 seconds, refer to the Troubleshooting procedure in Section 8-01.

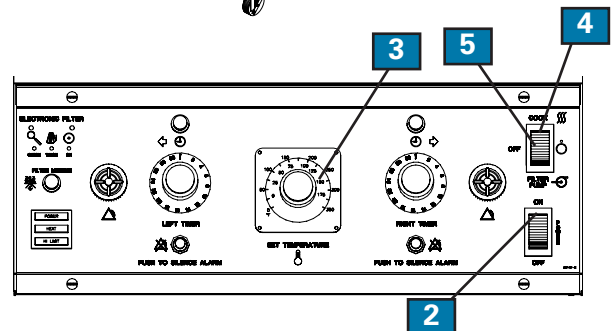
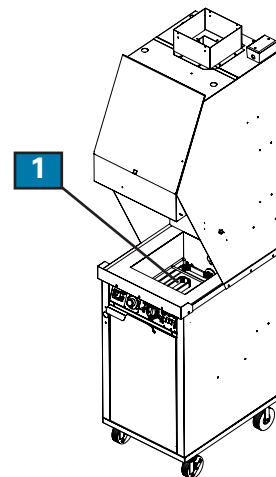

4-04. Filter Pump Test

The following test will ensure the Filter Pump is operating correctly.

CAUTION

- Ensure the Quick Disconnect **2** is cool before proceeding with this test.

1. Follow steps shown in Section 4-01.
2. Move the Power Switch to the ON **1** position.
3. Open Cabinet Door.
4. Place the palm of your hand over the Quick Disconnect **2** for the Filter Pan Hose.
5. Briefly move the Selector Switch to the FILTER PUMP **3** position then move the Selector Switch to the OFF **4** position. If suction is felt on your palm, the pump is operating correctly. Proceed to Section 4-05.

If no suction is felt, refer to the Troubleshooting procedure in Section 8-02.

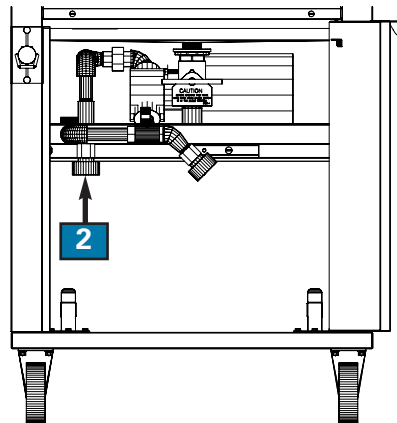
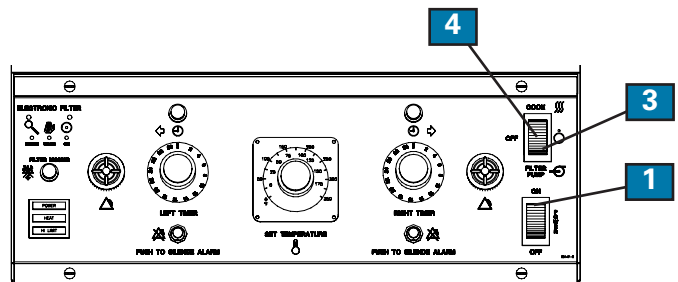

4-05. Perform Boil Out Procedure

Perform a Boil Out Procedure to remove any particles or debris that may have been left due to shipping. Follow Section 6-01 -Boil Out Procedure. After performing the Boil Out Procedure proceed to Section 4-06.

4-06. Clean Filter Pan

Thoroughly clean the Filter Pan to remove any particles or debris that may have been left due to shipping. Follow Section 6-02 -Cleaning the Filter Pan and replacing Filter Paper after Boil Out.

The unit's preparation is now complete. Please proceed to the Operation Section.



Notes:

5. Fryer Operation

This section describes how to operate the Giles Electric Fryer, Model WOG-20MP and WOG-20MP-VH.

CAUTION

- Ensure the fry kettle is positioned in a secure, safe location with the casters in the locked position.
- Due to the high temperature of cooking oil in your fryer during cooking, it is extremely important that the user exercise caution in operating this equipment to avoid personal injury.



Model: WOG-MP

5-01. Cooking Procedure

This section describes the cooking process for the unit.

1. Remove the Cooking Baskets from the unit.
2. Ensure the Power Switch is in the OFF **1** position.
3. Ensure the Selector Switch is in the OFF **2** position.

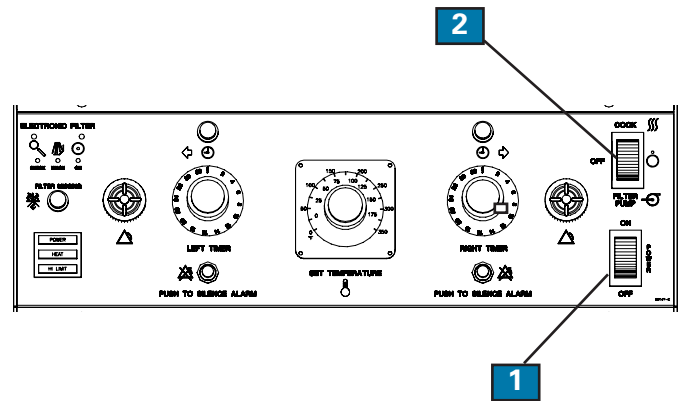

4. Ensure the Drain Valve is in the CLOSED **3** horizontal position.
5. Fill the Cooking Vat with liquid shortening to only the ADD **4** level. The Cooking Vat is filled to this level due to the expanding of liquid shortening after it is heated.

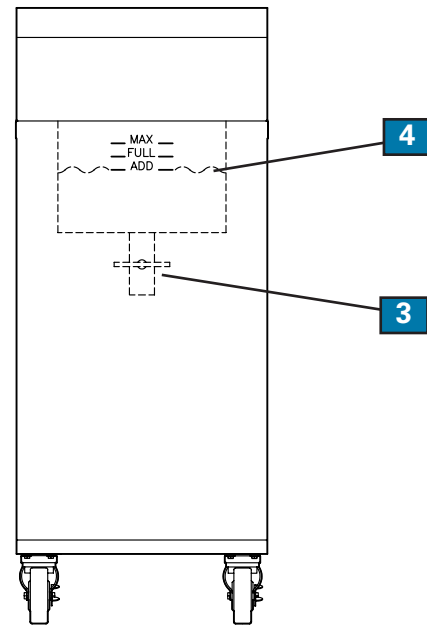

6. Place the Power Switch in the ON **5** position. The Power Light **6** will come on.
7. Rotate the Thermostat **7** to the desired temperature.
8. Place the Selector Switch in the COOK **8** position. The Heat Light **9** will come on.

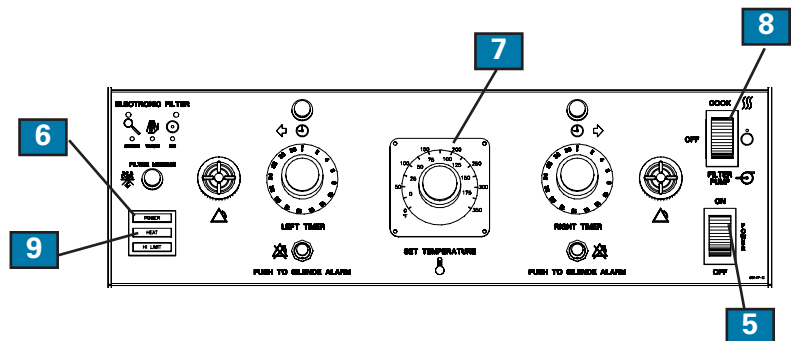

Continued next page

5-01. Cooking Procedure (continued from previous page)

9. Using the supplied Stir Paddle, occasionally stir the Liquid Shortening while it is preheating. This will remove cold areas in the Liquid Shortening and allow for more even cooking of the product.
10. Once the Liquid Shortening is preheated to the set temperature the Heat Light **10** will go out.

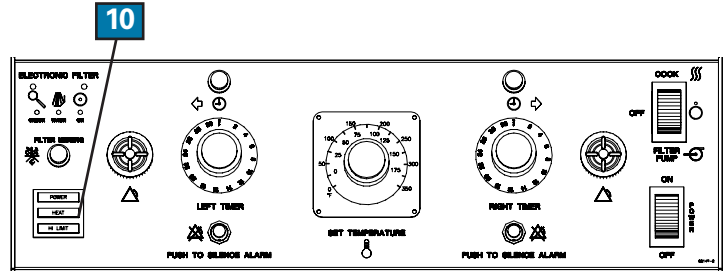

11. Check the Liquid Shortening level, it should now be at the FULL **11** Level . Add Liquid Shortening if needed.

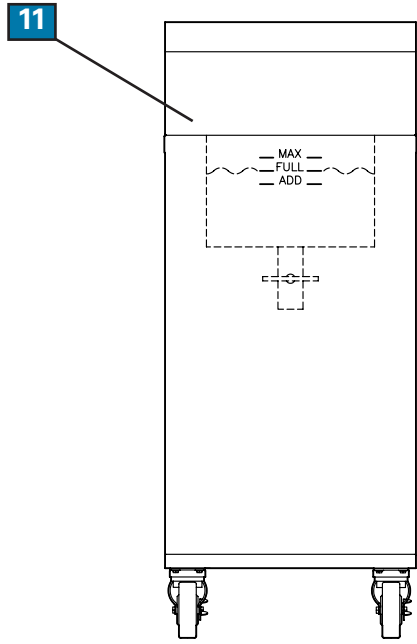

12. Place the Cooking Basket **12** on the Basket Hanger **13** .

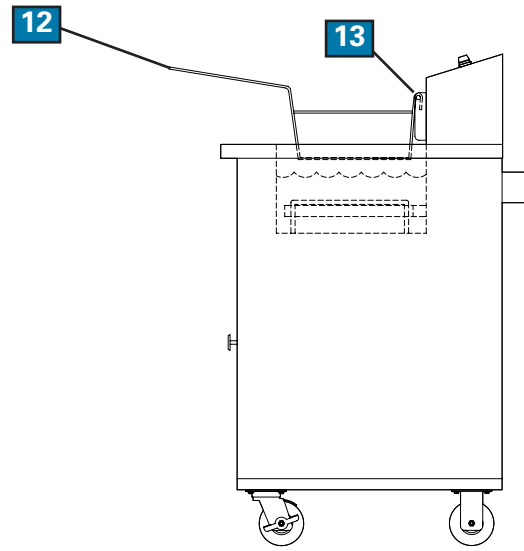

Continued next page

5-01. Cooking Procedure (continued from previous page)

NOTE:

- Uncooked product may be placed in the basket before or after the Cooking Basket has been placed in the Liquid Shortening.

WARNING

- Use extreme caution when placing product in the HOT liquid shortening, as the HOT liquid shortening could cause severe burns.

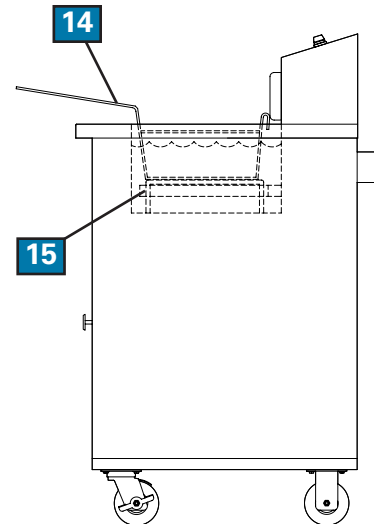

13. Place the Cooking Basket **14** into the Liquid Shortening and on top of the Basket Support **15**.

14. Rotate the Timer Knob **16** to the desired cooking timer. The Cooking Timer Indicator Light **17** will come on.

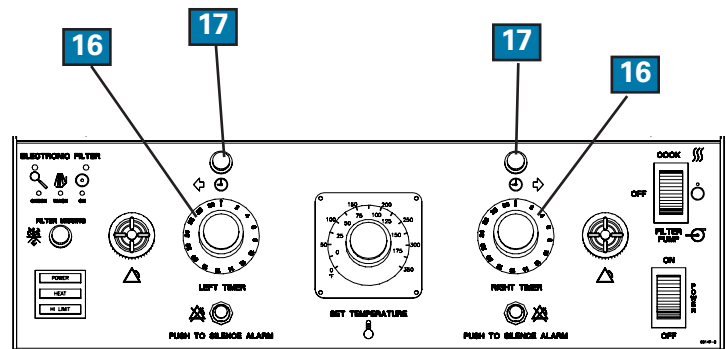

15. After approximately 50% of the cooking time has elapsed, using the supplied Metal Stir Paddle **18**, stir the product. This will help ensure the product is cooked evenly.

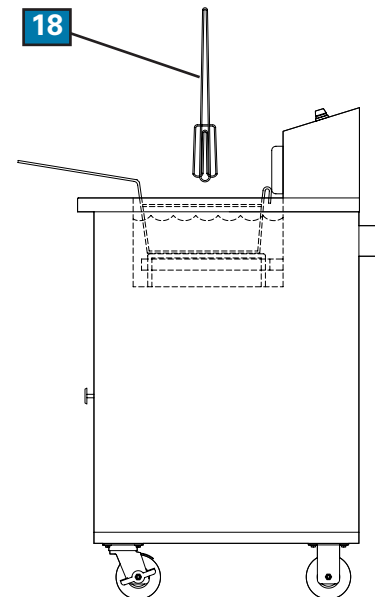

Continued next page

5-01. Cooking Procedure (continued from previous page)

16. At the end of the cooking time an alarm will sound. Press the appropriate (left or right) Push to Silence Alarm Button **19**.

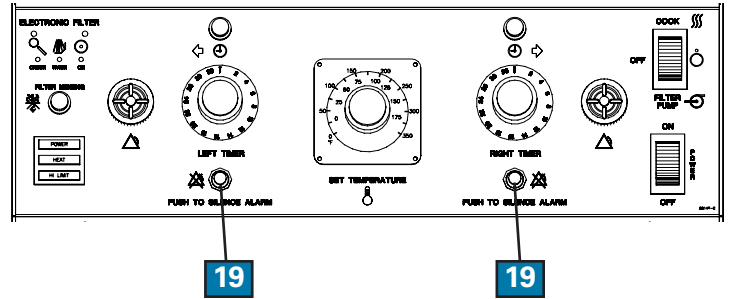

17. Using Oven Mitts, lift the Cooking Baskets **20** from the Liquid Shortening and place on the Basket Hanger **21**.

18. Allow the cooked product to adequately drain. Then, using Oven Mitts, remove the Cooking Baskets.

19. Place cooked product in an appropriate container.

20. Choose one of the following:

- a.) To continue cooking on the unit return to step 7 of this procedure.
- b.) To shut down the unit, see Section 5-5 Normal Shut-Down.

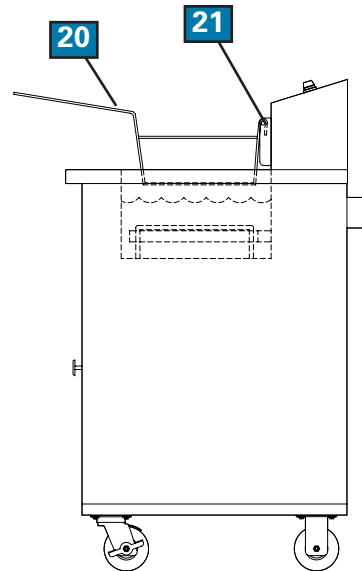

5-02. Filtering Liquid Shortening

This section describes how to filter Liquid Shortening through the built-in filtration system. The filtration system recirculates the Liquid Shortening through the Filter Pan, Filter Paper and Cooking Vat. By following this process you will increase the Liquid Shortening life up to 50%.

⚠ WARNING

- **Never try to filter cold Liquid Shortening, this could clog the filter pump and damage the unit. Liquid Shortening must be heated to a minimum of 200°F (93°C) before filtering.**

1. After the fourth cooking cycle is complete. Ensure the Power Switch is in the ON **1** position and the Liquid Shortening is at a minimum of 200°F (93°C).

2. Press the Selector Switch to the OFF **2** position.

3. Open the Cabinet Door. Wearing Oven Mitts, disconnect the Filter Pan Quick Disconnect Hose **3** then remove the Filter Pan **4** from the unit.

4. Ensure the Filter Pan has (2) sheets of Filter Paper installed correctly.

5. Add one package (4.8 ounces) of Giles Filter Powder (Part No. [72004](#)) into the Filter Pan.

6. Reposition the Filter Pan in the unit and reconnect the Filter Pan Quick Disconnect Hose **3**.

7. Screw Drain Extension **5** on to the Drain Coupling **6**.

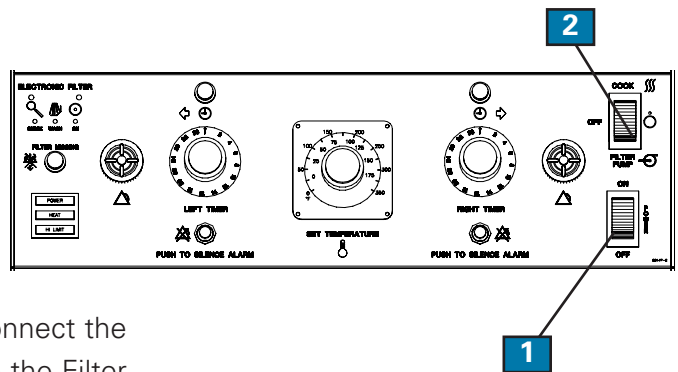

⚠ DANGER

- **In the following step Liquid Shortening is drained into the Filter Pan. Failure to ensure the fryer's Selector Switch is in the OFF position prior to draining may result in fire from the exposed Heating Elements. ALWAYS ENSURE THE SELECTOR SWITCH IS IN THE OFF POSITION BEFORE DRAINING LIQUID SHORTENING.**

8. Ensure the Selector Switch is in the OFF **2** position. Ensure the Oil Diverter Valve is in the TO FRYPOT **7** horizontal position. Slowly turn the Drain Valve Handle to the OPEN **8** vertical position. This will allow Liquid Shortening to drain into the Filter Pan.

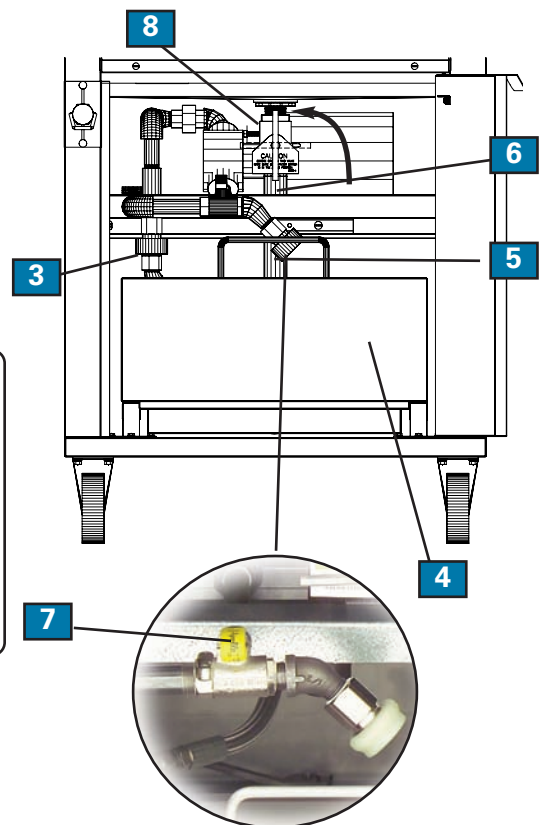

Continued next page

5-02. Filtering Liquid Shortening (continued from previous page)

NOTE:

- If the Cooking Vat does not drain use the supplied Kettle Drain Brush to break up the crumbs in the Cooking Vat Drain. **Be careful to not puncture the filter paper in the filter pan, this could cause the filter pump to clog and damage the unit.**

9. Once the Cooking Vat has completely drained into the Filter Pan, place the Selector Switch to the FILTER PUMP **9** position.
10. The Liquid Shortening will begin to recirculate **10** through the Filter Pan and back to the Cooking Vat. Leave the Drain Valve open and allow the Liquid Shortening to continually circulate for a minimum of 5 minutes.
11. Allow the Liquid Shortening to circulate for a minimum of 5 minutes, then turn the Drain Valve Handle to the CLOSE **11** horizontal position and allow the Cooking Vat to refill.
12. After the Cooking Vat has refilled, move the Selector Switch to the OFF **12** position.
13. Ensure the Cooking Vat contains the proper level of Liquid Shortening, add if needed.
14. **Using Oven Mitts**, unscrew the Drain Extension **13** from the Drain Coupling **14**, then disconnect Quick Disconnect **15** and then remove the Filter Pan.
15. Using supplied Crumb Scoop **16**, remove sediment from inside the Filter Pan.
16. Reinstall Filter Pan.
17. To continue cooking, See Section 5-1, Cooking Procedure.

To discontinue cooking, See Section 5-5, Normal Shut Down.

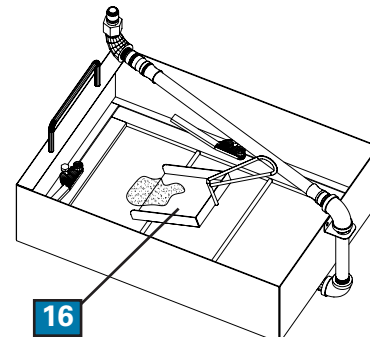
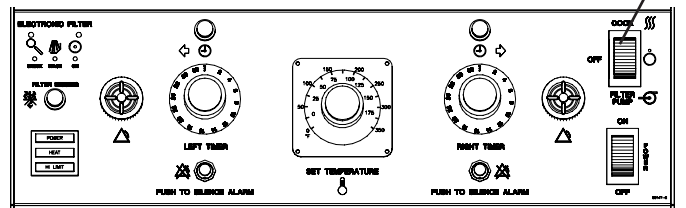
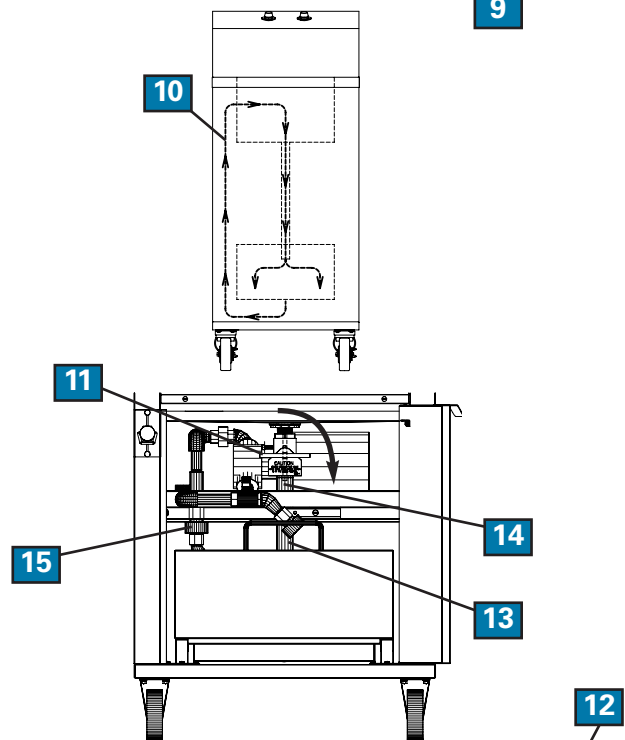
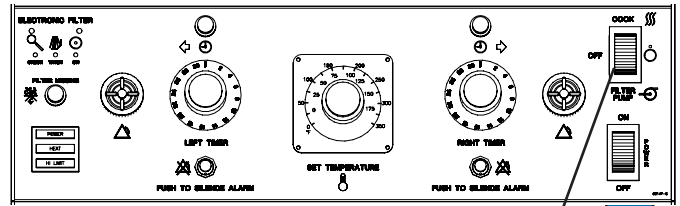

5-03. Removal of Liquid Shortening

This section describes how to remove Liquid Shortening from the unit. Liquid Shortening must be removed from the fryer before a Boil Out is performed. In this section a Giles Oil Caddy (not included) is used to transport the Liquid Shortening to a disposal location.

⚠ WARNING

- **Never try to remove cold Liquid Shortening using this procedure, this could clog the filter pump and damage the unit. Liquid Shortening must be heated to a minimum of 200°F (93°C) before following this procedure.**

1. If the Liquid Shortening is cold, heat to 200°F (93°C).
2. Ensure the Power Switch is in the ON **1** position.
3. Ensure the Selector Switch is in the OFF **2** position.
4. Ensure the Filter Pan **3** is in place and the quick disconnect hose **4** is connected to the unit.
5. Slowly turn the Drain Valve Handle to the OPEN **5** horizontal position and allow the Cooking Vat to completely drain.

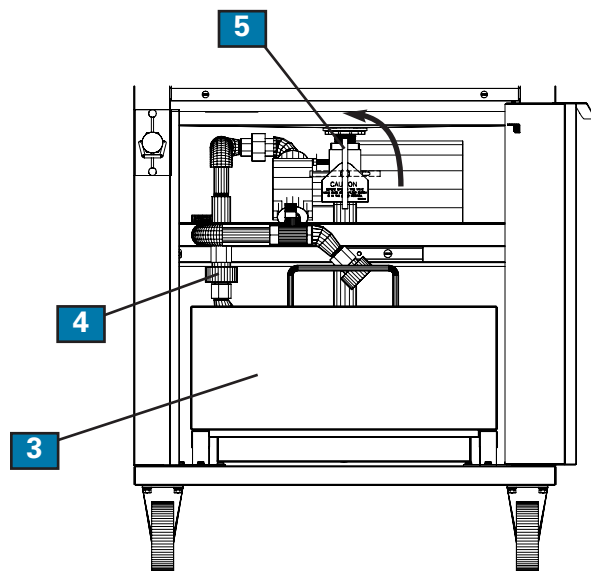
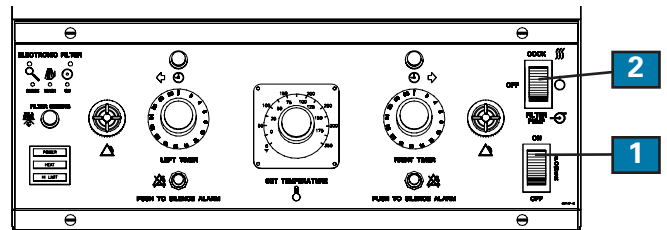

5-03. Removal of Liquid Shortening (continued from previous page)

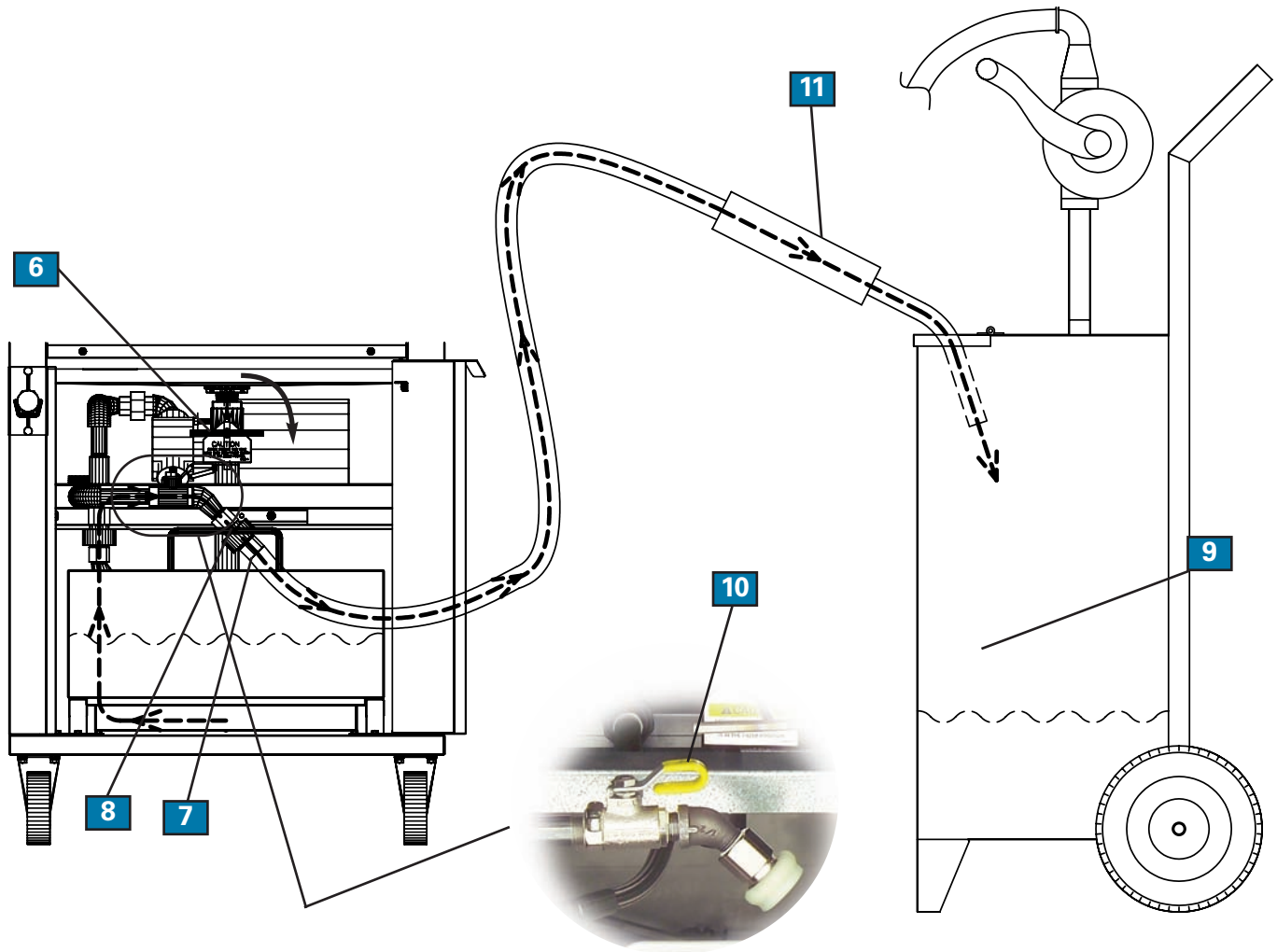

6. After the Cooking Vat has completely drained, Turn the Drain Valve Handle to the CLOSED **6** horizontal position.
7. Connect the Discharge Hose **7** to the Discharge Hose Coupling **8**.
8. Place the discharge end into a Hot Oil Disposal Container **9** (Giles Oil Caddy shown).
9. Turn the Oil Diverter Valve to the TO DISCHARGE HOSE **10** vertical position.
10. **Be sure to wear Oven Mitts if holding the Discharge Hose, as the hose will become very hot.** Move the Selector Switch to the PUMP/FILTER **11** position and allow the liquid shortening to pump into the Disposal Container.

Continued next page 

5-03. Removal of Liquid Shortening (continued from previous page)

11. After the Liquid Shortening is removed from the Filter Pan, move the Selector Switch to the OFF **12** position.
12. Move the Power Switch to the OFF **13** position.

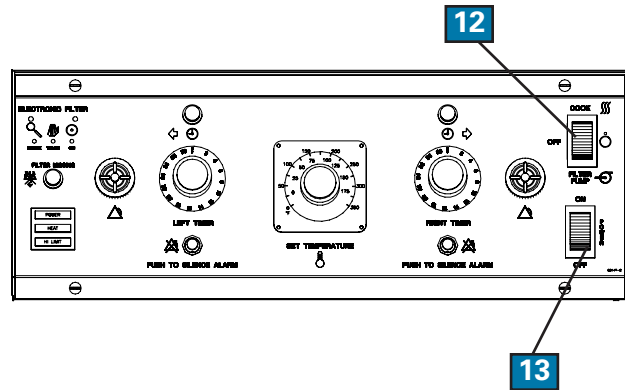

13. Turn the Oil Diverter Valve handle to the TO FRYPOT horizontal **14** position.
14. **Wearing Oven Mitts** remove the Discharge Hose from the Discharge Hose Coupling **15** and drain the excess Liquid Shortening remaining in the hose into the Oil Disposal Container.
15. Thoroughly clean the Filter Pan.
16. To perform a Boil Out on the unit see Section 6-1 Boil Out Procedure.

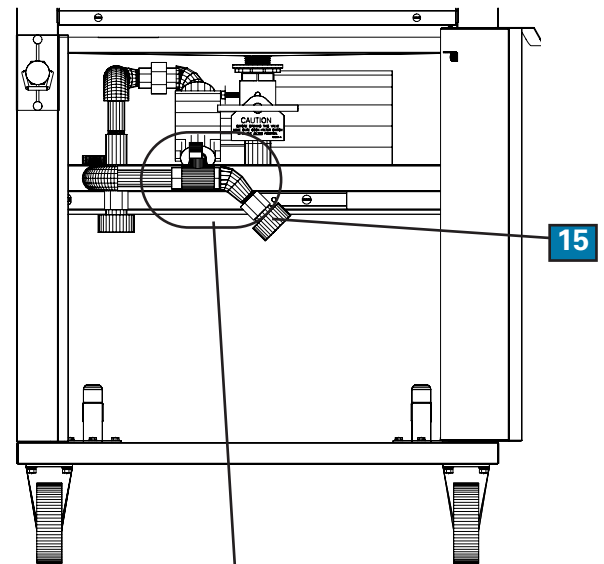

To shut down the unit see Section 5-5 Normal Shut-Down.

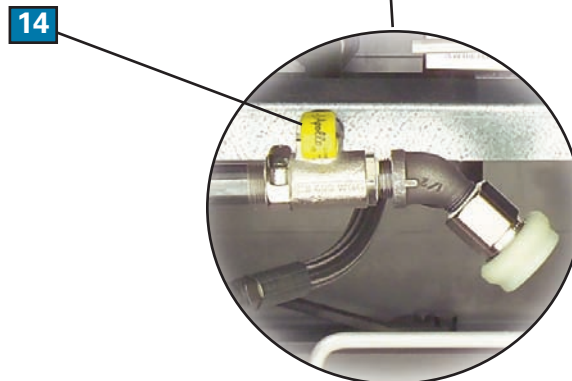

5-04. Normal Shut-Down

This section explains the process of shutting the unit down.

1. Place the Selector Switch in the OFF **1** position.
2. Rotate the Thermostat Knob **2** to 0°F.
3. Place the Power Switch in the OFF **3** position, the Power Light **4** will go off.
4. If required, turn off the fryer circuit breaker in the main circuit breaker box to remove power to the unit.

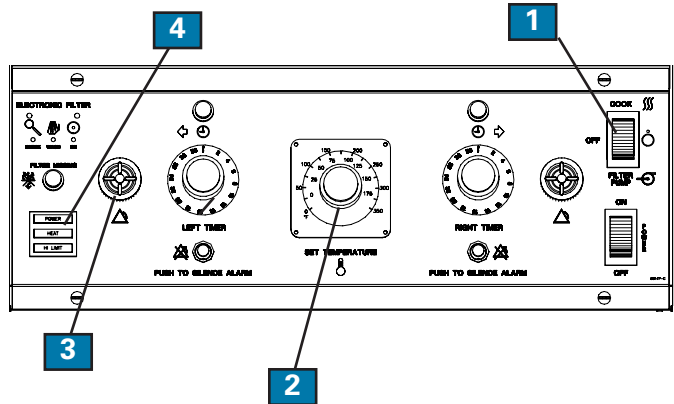

5-05. Emergency Shut-Down

In case of emergency, remove power to the unit by turning off the facility circuit breaker.



Notes:

6. Cleaning

This section describes the procedures to be followed in cleaning the WOG-MP and WOG-MP-VH. The unit should be cleaned on a daily basis.

⚠ DANGER

- **DO NOT** hose down the WOG-MP and WOG-MP-VH interior or exterior with water.
- Failure to comply with this **DANGER** notices will result in death or serious injury, equipment/property damage, and void the warranty.

6-01. Boil-Out Procedure (Cleaning the Cooking Vat)

This section describes how to clean the Cooking Vat in the unit. This process is referred to as "Boil-Out". A "Boil-Out" must be performed before cooking with new equipment and should be performed each time liquid shortening is removed from the unit.

For proper operation of the fryer, the Boil-Out procedure should be carried out every 7 to 14 days.

⚠ DANGER

- **DO NOT under any circumstances leave the unit unattended during the Boil-Out procedure as heat must be carefully monitored to prevent the Cooking Vat from overflowing. Overflow of the Cooking Vat may result in serious equipment damage.**

1. Remove Liquid Shortening from the unit, see Section 5-03. Removal of Liquid Shortening.
2. Ensure the Drain Valve is in the CLOSED **1** horizontal position and the Power Switch is in the OFF position.
3. Fill the Cooking Vat with water to the FULL level **2**.
4. Following the directions on the Giles Boil-Out Container, add the recommend amount of Boil-Out to the Cooking Vat.

⚠ CAUTION

- **If using a cleaner other than Giles Boil-Out pay close attention to the instructions listed on the container. Many commercially available cleaners use caustic chemicals which require special precautions. If used improperly, these chemicals may cause damage to the fryer and potentially injure the user.**

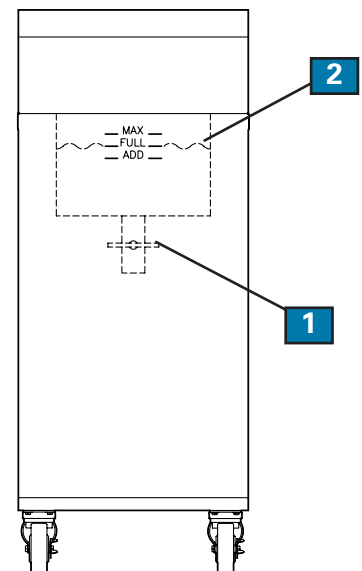

Continued next page

6-01. Boil Out Procedure (continued from previous page)

5. Place the Power Switch in the ON **3** position.
6. Place the Selector Switch in the COOK **4** position.
7. Rotate the Thermostat Knob to 200°F **5**. Allow the Boil Out Solution to heat to 200°F.
8. Heat the Boil Out Solution as directed on the Boil Solution Container.
9. At the completion of the Boil Out time, place the Selector Switch to the OFF **6** position and the Power Switch to the OFF **7** position.
10. **Disconnect Quick Disconnect Hose, remove the Filter Pan, then remove the Filter Pan Cover.**

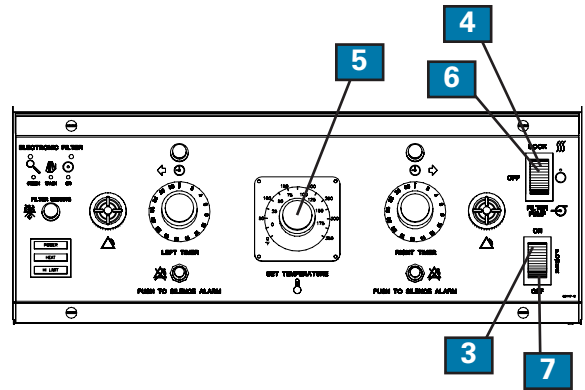

WARNING

- **DO NOT drain the Boil-Out into the Filter Pan! Contents are corrosive and will cause damage to the Filter Pan, the Hold-Down Frame, and the Filter Pump. Failure to comply may result in minor or moderate injury, equipment/property damage, and void the warranty.**

11. Position a suitable **Heat Resistant Container** **8** (not supplied with the unit) beneath the Fryer Drain.

CAUTION

- **Always ensure the container which is used for this step is heat resistant up to 300°F (148°C). Plastic is generally not safe for this purpose, as it may melt or break. Metal containers which do not leak are preferable to containers made of other materials. Failure to comply with this caution may result in serious injury.**

12. Slowly turn the Drain Valve Handle counter-clockwise to the OPEN **9** vertical position.

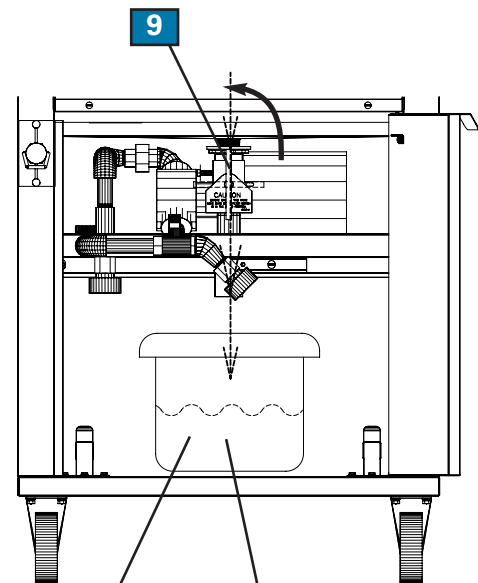

**Heat Resistant Container
(not supplied with unit)
DO NOT USE THE FILTER PAN!!!**

6-01. Boil Out Procedure (continued from previous page)

13. Rinse and flush the Cooking Vat thoroughly with tap water.

CAUTION

- When rinsing and flushing with tap water and the drain open be careful to not cause the Heat Resistant container to overflow.

14. Dry Cooking Vat with a clean dry towel.

15. Slowly turn the Drain Valve Handle clockwise to the CLOSE **10** horizontal position.

16. Clean the Filter Pan and replace the Filter Paper; follow the directions in Section 6-02, Cleaning of Filter Pan and replacing the Filter Paper after Boil Out.

17. Position the Filter Pan **11** under the unit and connect the Filter Pan Quick Disconnect Hose **12**.

18. To begin cooking on the unit, see Section 5-01.

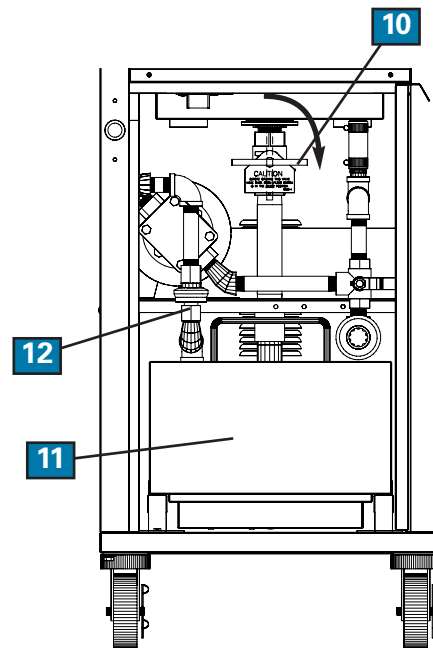

6-02. Cleaning the Filter Pan and replacing Filter Paper after Boil Out

This section explains the process for cleaning the Filter Pan and the replacement of the Filter Paper. This process should be carried out each time you perform a Boil Out Procedure (Section 5-05).

CAUTION

• Use Thermal Mitts for protection from hot parts.

1. Follow the Normal Shut-Down procedure, see Section 5-05.
2. Remove the Drain Extension **1**.
3. Remove the Filter Pan **2**.
4. Using *Crumb Scoop provided with the unit, remove the accumulated breadding and residue from the edge of the Hold Down Frame **3** and surface of the Filter Paper **4**.
5. Turn the four Levers **5** to disengage the Hold-Down Frame from the bottom of Filter Pan.
6. Remove the Hold-Down Frame **3**, then clean and dry thoroughly.
7. Grasp one end of the Filter Paper **4** and carefully roll up both sheets, then discard them.
8. Remove the Screen **6**, then clean and dry thoroughly.
9. Thoroughly clean and dry the Filter Pan **7**.
10. Reassemble the Filter Pan using (2) new sheets of Filter Paper.
11. Reinstall the Filter Pan Assembly, then the Drain Extension.

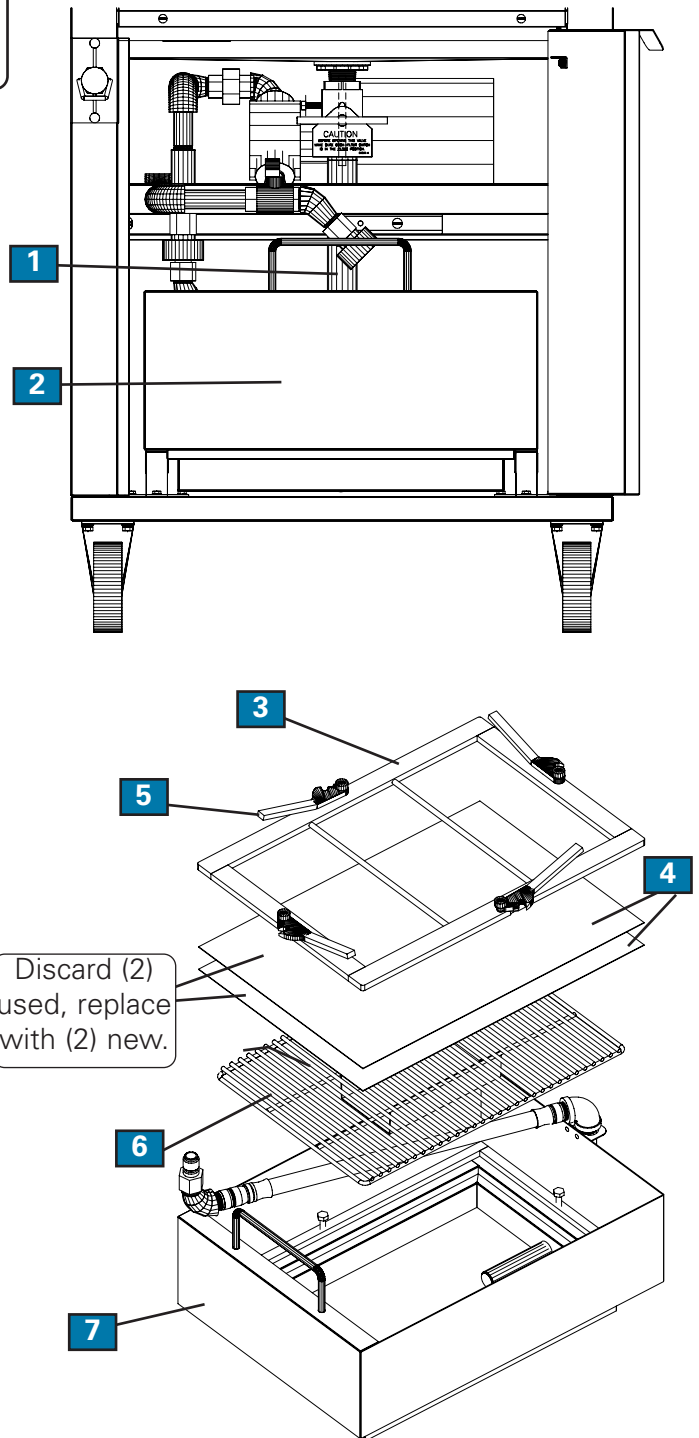

* -Not shown

6-03. Cleaning the Filter Pan and replacing Filter Paper daily

This section explains the process for cleaning the Filter Pan and the replacement of the Filter Paper daily. This process should be carried out daily.

CAUTION

• Use Thermal Mitts for protection from hot parts.

1. Follow the Normal Shut-Down procedure, see Section 5-05.
2. Remove the Drain Extension **1**.
3. Remove the Filter Pan **2**.
4. Using *Crumb Scoop provided with the unit, remove the accumulated breadings and residue from the edge of the Hold Down Frame **3** and surface of the Filter Paper **4**.
5. Turn the four Levers **5** to disengage the Hold-Down Frame from the bottom of Filter Pan.
6. Remove the Hold-Down Frame **3**, then clean and dry thoroughly.
7. Grasp one end of the top Filter Paper **4** and carefully roll up, then discard.
8. Grasp bottom Filter Paper **6** by both ends and remove, retain this sheet for reuse.
9. Remove the Screen **7**, then clean and dry thoroughly.
10. Thoroughly clean and dry the Filter Pan **8**.
11. Reassemble the Filter Pan using (1) new sheet of Filter Paper **9** and the previously removed bottom sheet **6**.
12. Reinstall the Filter Pan Assembly, then the Drain Extension.

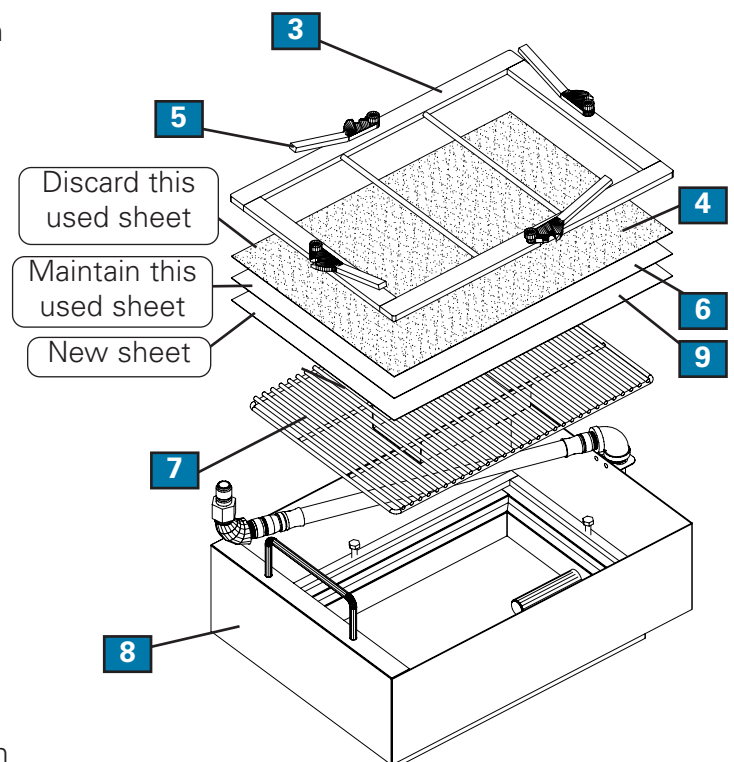
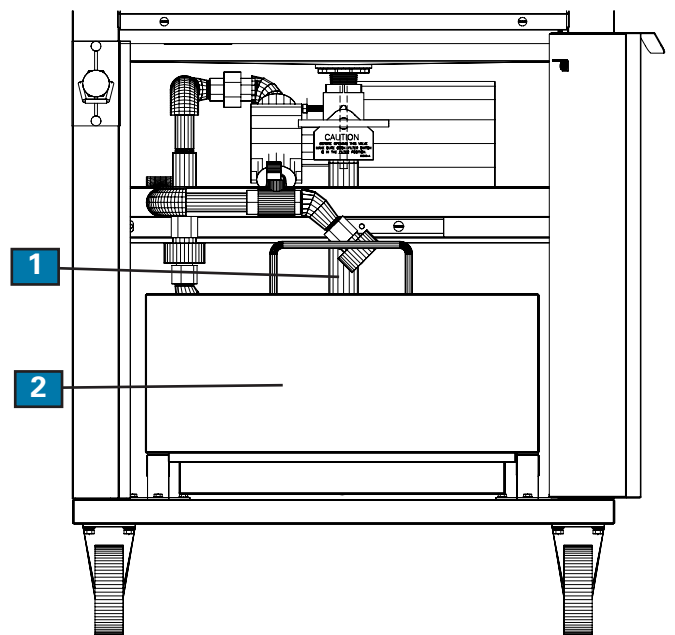



Notes:

7. Ventless Hood

This section applies to the Ventless Hood (WOG-MP-VH) models only. It describes the operation and maintenance of the Ventless Hood and the Filters contained in the hood.

7-01. Hood Operation

This section describes how to start the Ventless Hood. Make sure all the Filters are in place before operating the unit.

- Place the Power Switch in the ON **1** position, (if ILS, press and hold the "Push and Hold to Start" switch ***2** for 5 seconds) the Power Light **3** and EAC On light **4** will come on and the UV Sight Window ****5** will illuminate.

This will turn the unit on and the ventless hood fan will begin running.

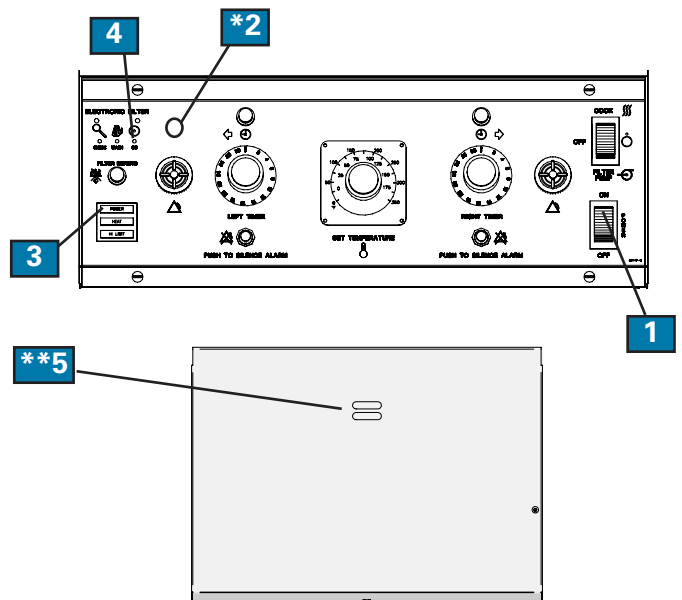

* - ILS Only
 ** - UV Only

7-02. Filters

This section describes each Filter in the Ventless Hood.

7-02.01. Ventless Hood Filter Table

Filter	When to clean or replace	How to remove	How to clean	How to install
Baffle Filter	Clean daily	Section 7-02.06	Section 7-02.07	Section 7-02.08
EAC Filter	Clean daily	Section 7-02.08	Section 7-02.11	Section 7-02.09
Charcoal Filter	Replace every 30 days, P/N 30248	Section 7-02.12.	Never clean, only replace Section 7-02.15	Section 7-02.13.
Ultra Violet Lamp	Clean every 30 days Replace annually	Section 7-02-15	Section 7-02.14	Section 7-02.16

7-02.02. Baffle Filter Removal

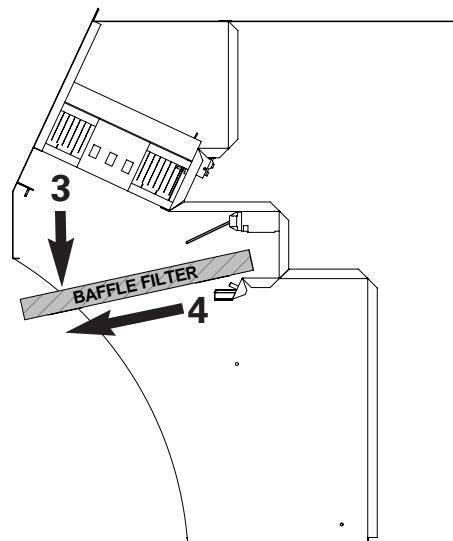
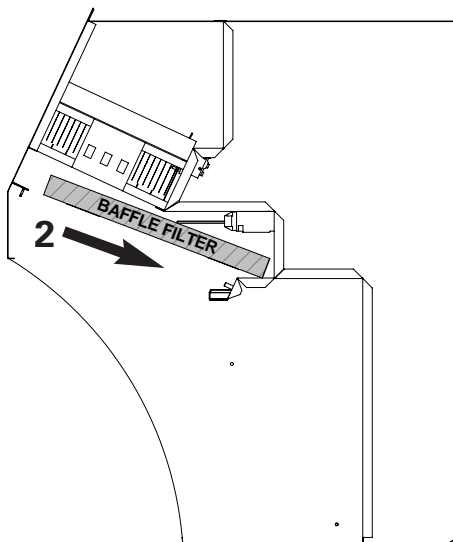
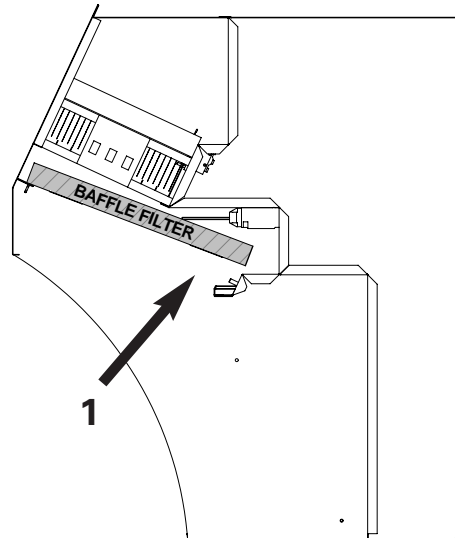
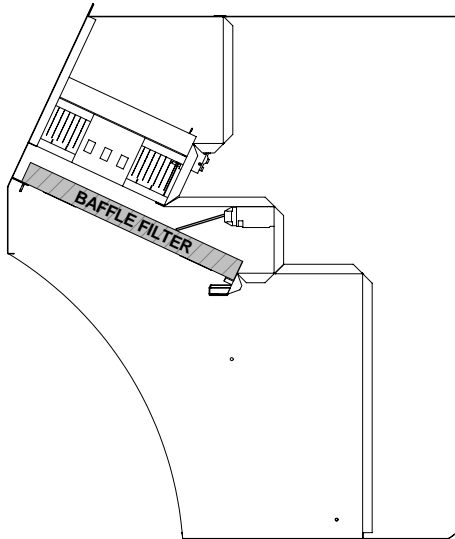

7-02.03. Baffle Filter Installation

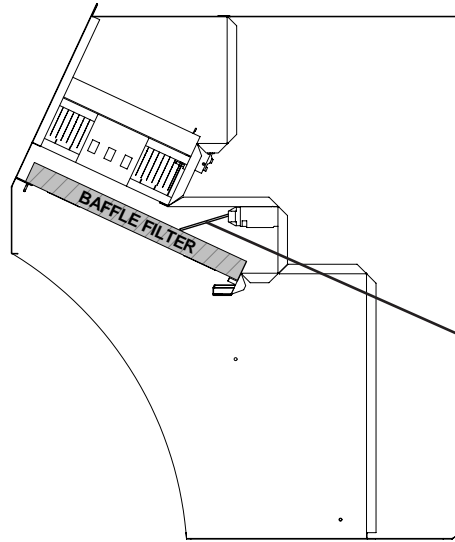
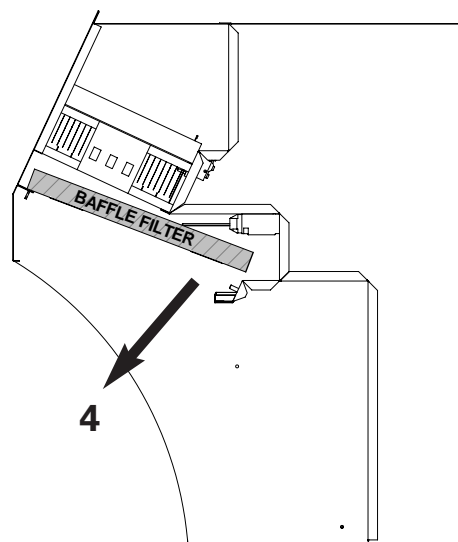
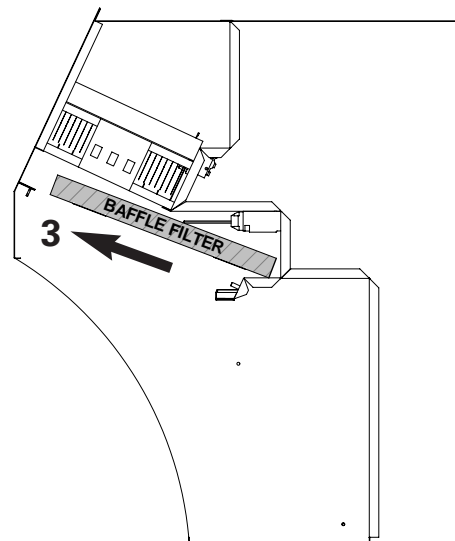
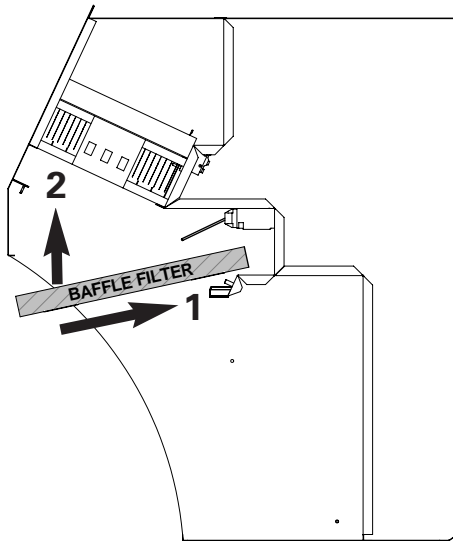

Switch arm must be actuated by the Baffle Filter as shown

7-02.04. Baffle Filter Missing

If the Baffle Filter is missing or not in place correctly the Filter Missing Light **1** will come on. See Section 7-2.03 Baffle Filter Installation.

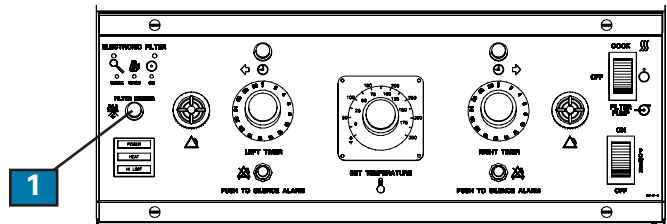

7-02.05. Baffle Filter Cleaning

The Baffle Filter should be cleaned daily. Place the Baffle Filter in a sink and clean with a mild degreaser. Dry thoroughly, then reinstall in the unit.

7-02.06. EAC Filter Removal

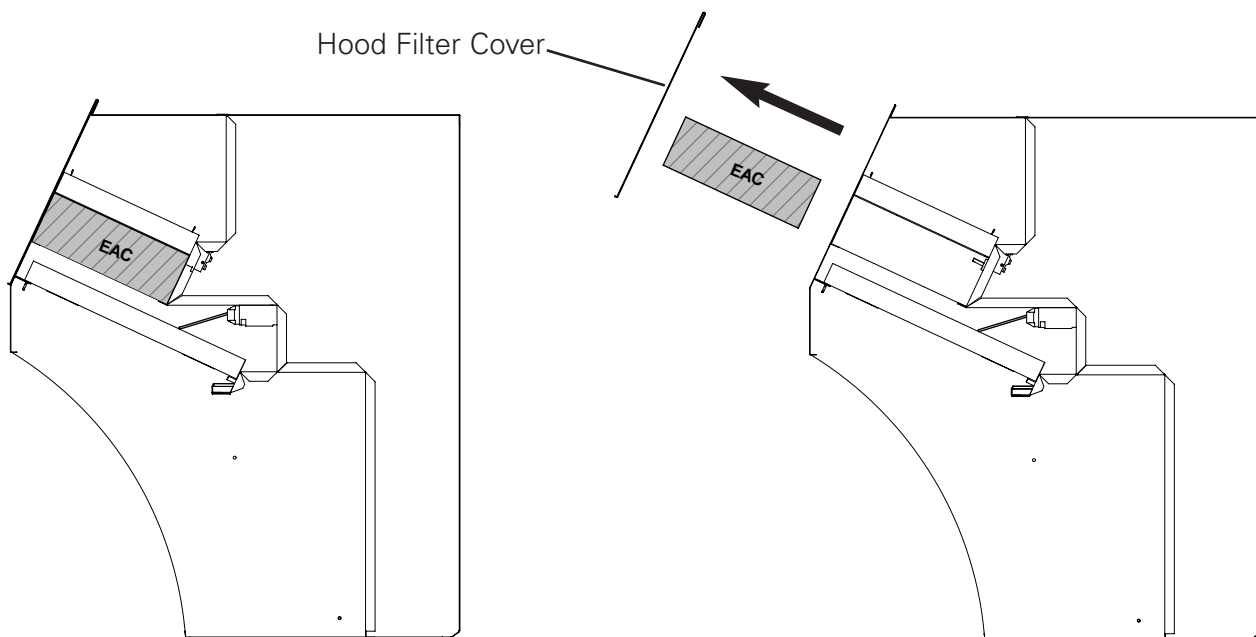

7-02.07. EAC Filter Installation

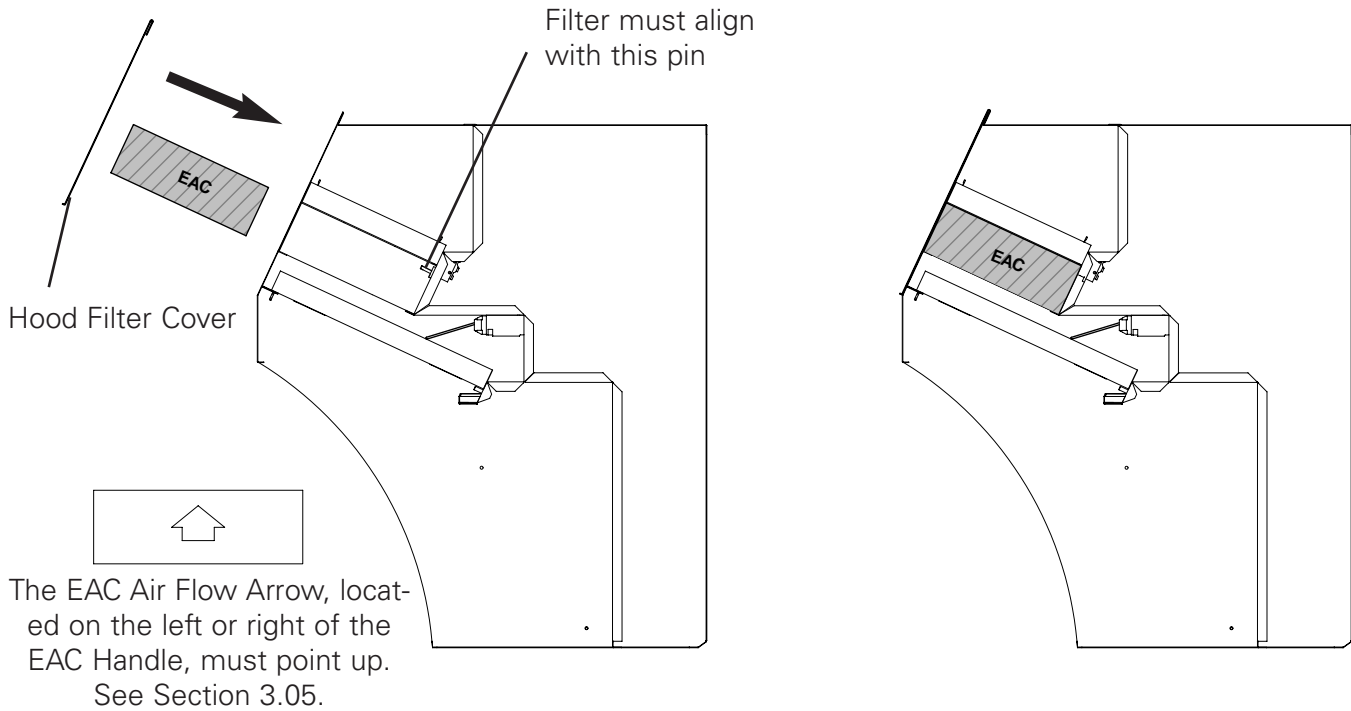

7-02.08. EAC Filter Status

The three indicator lights on the Control Panel display the status of the EAC Filter.

- 1** ON The EAC Filter is in place and powered.
- 2** WASH The EAC Filter is becoming excessively dirty and must be cleaned. If this light is on for more than 2 minutes an intermittent alarm will sound, the Elements and the Heat Light will turn off. (Do not use the wash light as a signal for routine cleaning of the EAC, doing so will significantly decrease the life of the charcoal filter. Clean the EAC daily for best performance and extended charcoal filter life.)
- 3** CHECK The EAC Filter is not operating; either the filter is not properly connected to its power source or it is damaged. If this light is on for more than 2 minutes an intermittent alarm will sound, the Elements and the Heat Light will turn off.

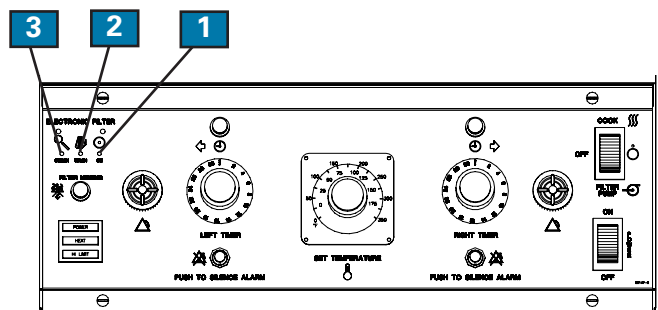

7-02.09. EAC Filter Cleaning

CAUTION

- Do not bend the fins or break the ionizer wires on the EAC as this will prevent the EAC from working properly and potentially void the warranty.

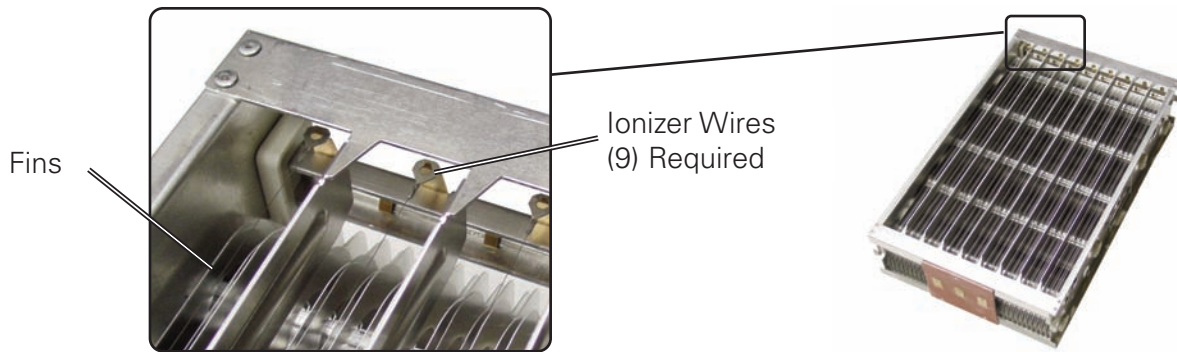

1. Mix 1/2 Gallon of a mild non-caustic biodegradable degreaser, such as Simple Green or Clean Magic, with 6.5 gallons of water in the included Soak Tank **1**.

NOTE:

- The mixed solution in the Soak Tank should last up to 30 days without being changed.

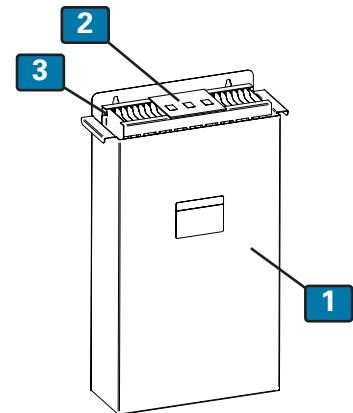

2. Holding the contact plate **2** on the EAC **3** slowly lower the filter into the Soak Tank.
3. After allowing the EAC to soak for 20 to 30 minutes, using the contact plate **2**, lift the EAC up and down approximately 1" to 2" to help remove the grease residue.
4. Slowly remove the EAC from the tank and rinse clean in a sink using hot water.
5. Allow the EAC to air dry, thoroughly.

CAUTION

- Do not dry the EAC either by running the hood to air dry or by running the appliance to heat dry. This could potentially damage the EAC causing improper operation and voiding the warranty.

7-02.10. Charcoal Filter Removal

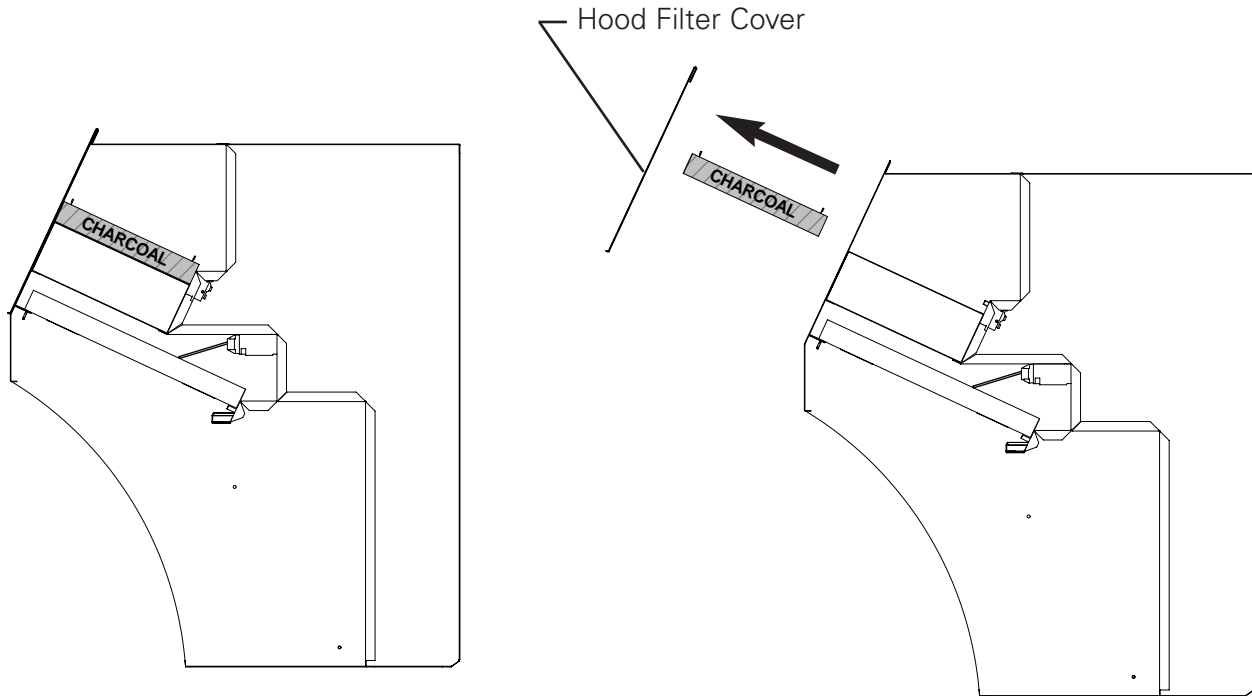

7-02.11. Charcoal Filter Installation

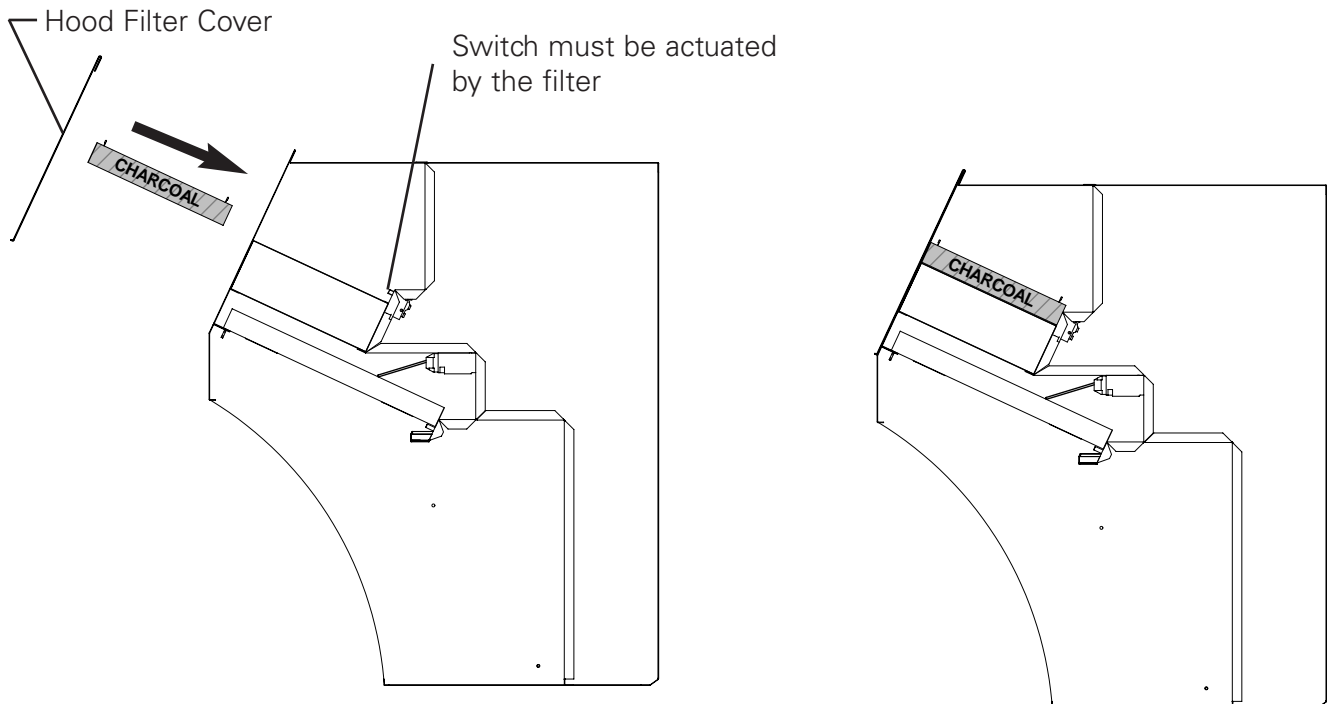

7-02.12. Charcoal Filter Missing

If the Charcoal Filter is missing or not in place correctly and the unit is on, the Filter Missing Light **1** will come on. See Section 7-02.11 Charcoal Filter Installation.

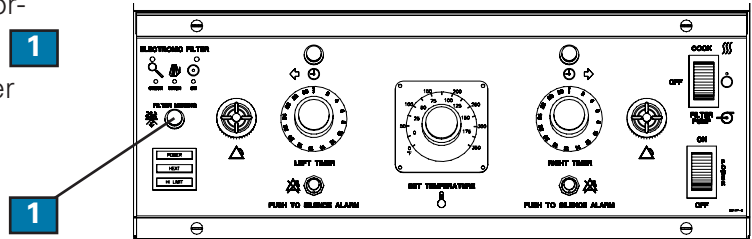

7-02.13. Charcoal Filter Replacement

Never attempt to clean the Charcoal Filter. This could cause damage to the unit.

Replace the Charcoal Filter every 30 days. Use Replacement Part No. [30248](#).

7-02.14. Ultra Violet Lamp Cleaning

CAUTION

- **Do Not touch or handle UV Lamp with bare hands. This will greatly reduce the life of the bulb.**

To be accomplished every 30 days

1. Place power switch to the OFF position.
2. Remove filter access cover.
3. Loosen and remove thumb screws at the top of lamp guard.
4. Lightly spray a mild non-caustic biodegradable degreaser, such as Simple Green, onto the UV Lamp and wipe off residue with a dry, lint free cloth.
5. Re-install lamp guard.

7-02.15. Ultra Violet Lamp Removal

1. Place power switch **1** to the OFF position.
2. Remove filter access cover **2**.
3. Disconnect UV Lamp wiring harness from power supply wiring harness **3**.
4. Loosen and remove thumb screws and UV lamp guard **4**.
5. Remove lamp from holding brackets **5**.

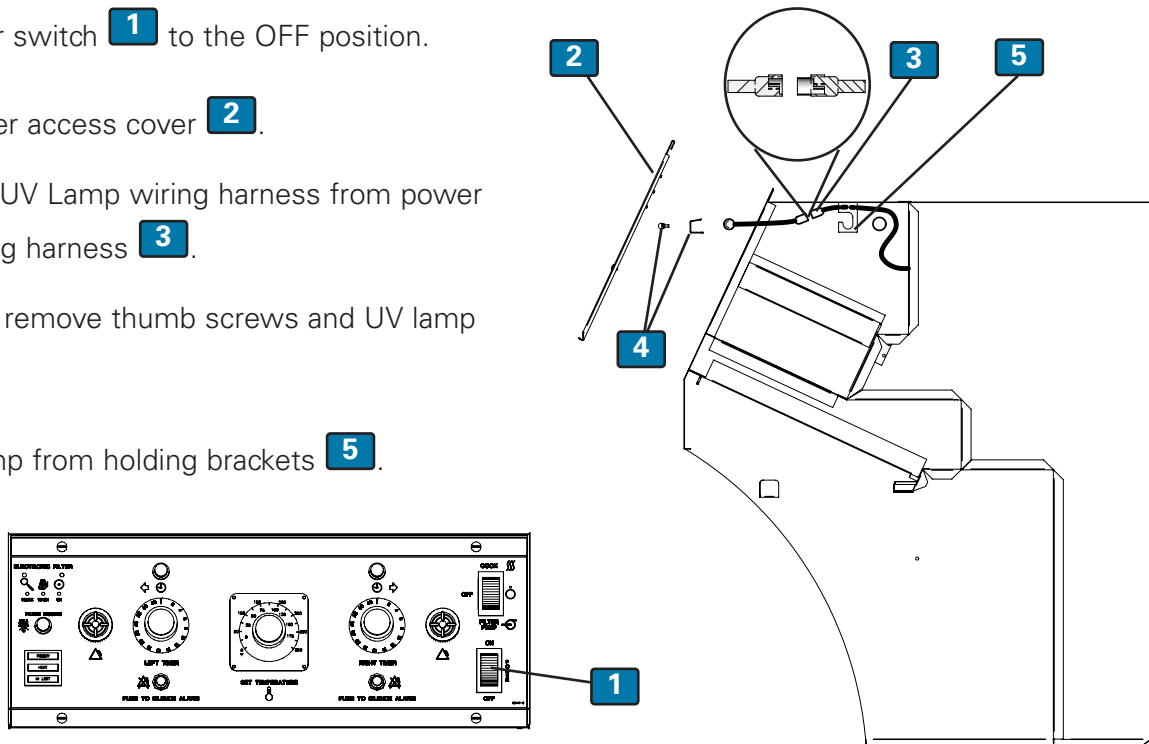

7-02.16. Ultra Violet Lamp Installation

1. Install new UV lamp in holding brackets **1**.
2. Install lamp guard and tighten thumb screws **2**.
3. Connect UV Lamp wiring harness to power supply wiring harness **3**.
4. Install filters and filter access cover **4**.
5. Place power switch **5** to the ON position.

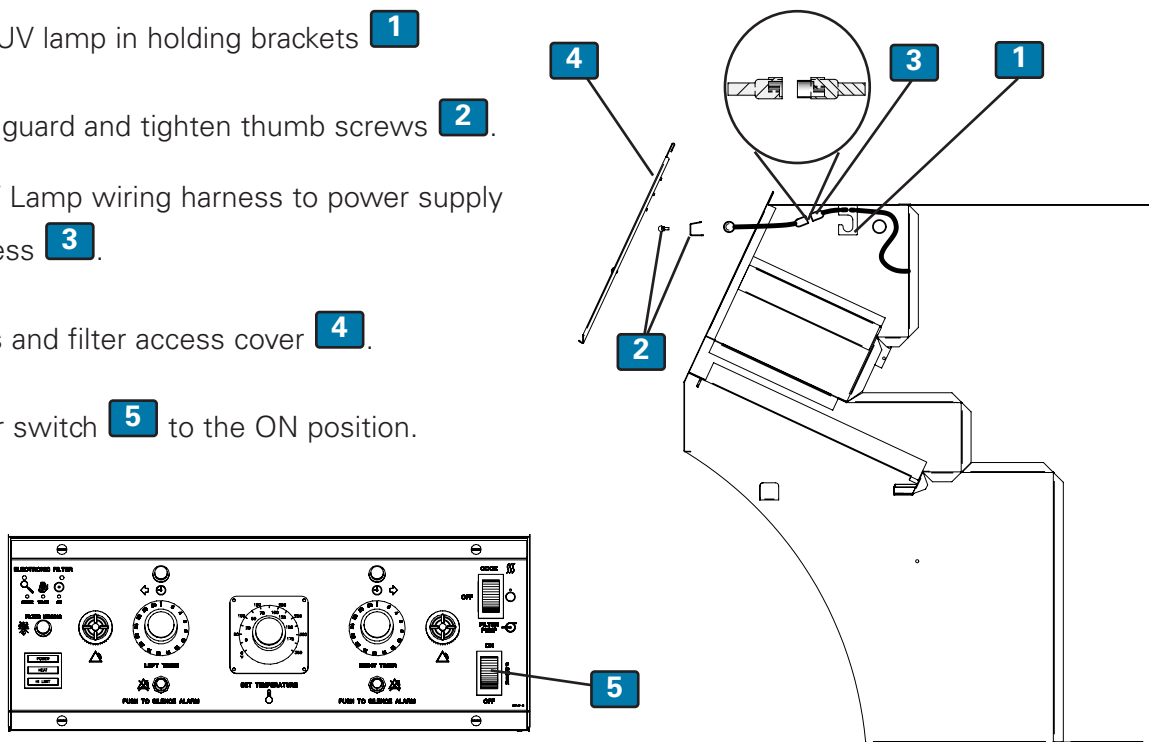

7-02.14. Hood Filter Alarm Chart

Alarm Sound	What will happen	Filter effected	Cause	Solution	See Section
Continuous beep	Alarm will sound and the power to the Fryer Heating Elements will shut off. (If ILS, the power to the Fryer and Hood will shut off)	Charcoal	Filter dirty	Replace Filter	7-02.10. and 7-02.13.
Continuous beep	Alarm will sound and the power to the Fryer Heating Elements will shut off. (If ILS, the power to the Fryer and Hood will shut off)	Baffle	Filter dirty	Clean Filter	7-02.02. and 7-02.05.
Intermittent beeping	Alarm will sound 2 minutes then power to the Fryer Heating Elements will shut off. (If ILS, the power to the appliance and hood will shut off)	E.A.C.	Filter dirty	Clean Filter	4-02.06. and 4-02.09.

7-03. Maintenance

This Section describes periodic maintenance for the Ventless Hood (WOG-MP-VH) System. Performance of these procedure will maintain the unit's efficiency over time.

A **Maintenance and Service Log** is provided in this manual, see Table 7-03.6.

7-03.01. Monthly Interlock Check

Your Giles Ventless Hood System incorporates an Interlock System to ensure the unit is operated in a safe and effective manner. Testing of the Interlock System should be conducted MONTHLY in the following manner. Using the Maintenance and Service Log, see Table 7-3.6., place a check in the box that corresponds with the test being performed. If a problem is found call your service representative.

1. **Baffle Filter Check**-With the Power Switch in the "OFF" position remove the grease baffle filter. Place the Power Switch in the "ON" position and the Selector Switch in the "COOK" position. The heat light should not come on. Turn the Power Switch to the "OFF" position and reinstall the grease baffle filter into the hood.
2. **EAC Filter Check**-Remove the EAC. Place the Power Switch in the "ON" position and the Selector Switch in the "OFF" position, wait two minutes and then move the Selector Switch to the "ON" position. The heat light should not come on. Return Selector Switch to its "OFF" position. Reinstall the EAC.
3. **Charcoal Filter Check**-Remove the Charcoal Filter. Place the Power Switch in the "ON" position and the Selector Switch in the "COOK" position. The heat light should not come on. Return all switches to their "OFF" position. Reinstall the charcoal filter.
4. **Filter Clogged Check**-Place the Power Switch in the "ON" position and the Selector Switch in the "COOK" position. Place a piece of filter paper over the Grease Baffle Filter. The heat light should not come on. Return all switches to their "OFF" position. Remove the test paper.

7-03.02. Quarterly Hood Cleaning

Remove power from the unit. Remove the Filter Cover and all Filters from the hood. Using a mild degreaser clean the entire Hood Plenum and Blower Sections. The hood must be cleaned every 3 months.

7-03.03. Semi-Annual Fire Suppression System Service

Service of the Fire Suppression System is to be conducted by qualified fire equipment personnel. As a minimum, field inspection of the Fire Suppression System is to be accomplished semi-annually by qualified fire equipment service personnel. Such maintenance shall consist of the following **(Consult the Giles Enterprises Design Installation, Recharge and Maintenance Manual for complete servicing guidelines)**.

Place fire extinguishing system locking bar on fire system when servicing hood.

1. Remove charging cartridge, inspect gasket for cuts and elasticity, coat gasket with extreme temperature grease and reinstall. See Section 2-08. -Fusible Link and Gas Cartridge Locations
2. Remove tank, verify chemical is at proper level, clean and coat O-ring with extreme temperature grease and reinstall. See Section 2-09. -Fire Extinguisher Nozzle and Tank Locations
3. Check all nozzles to insure they are free of cooking grease buildup.
4. Test the remote manual pull station for activation and wear.
5. Install test link and cut to simulate automatic actuation.
6. Clean and inspect fusible links. See Section 2-08. -Fusible Link and Gas Cartridge Locations
7. Inspect wire rope for wear at pulleys and detectors and replace if necessary.
8. Record maintenance date and maintain in a permanent file.

7-03.04. Annual Fire Suppression System Service

Same as Semi-Annual but all fusible links must be replaced with new fusible links. See Section 2-08. - Fusible Link and Gas Cartridge Locations

7-03.05. Twelve Year Suppression System Service

Same as Annual except for the following.

1. Replace R-102 fire suppression chemical.
2. Hydrostatically test the tank and cartridge.
3. Flow test the regulator.

Ventless Hood

Model: WOG-MP & WOG-MP-VH

7-03.06. Maintenance and Service Log

Check							Initial/Date	Check							Initial/Date
✓	✓	✓	✓				ABC 1/2/03	1	2	3	4				
1	2	3	4					1	2	3	4				
1	2	3	4	5				1	2	3	4	5			
1	2	3	4					1	2	3	4				
1	2	3	4	5	6*			1	2	3	4	5	6*		
1	2	3	4					1	2	3	4				
1	2	3	4	5				1	2	3	4	5			
1	2	3	4					1	2	3	4				
1	2	3	4	5	6*	7*		1	2	3	4	5	6*	7*	
1	2	3	4					1	2	3	4				
1	2	3	4	5				1	2	3	4	5			
1	2	3	4					1	2	3	4				
1	2	3	4	5	6*			1	2	3	4	5	6*		
1	2	3	4					1	2	3	4				
1	2	3	4	5				1	2	3	4	5			
1	2	3	4					1	2	3	4				
1	2	3	4	5	6*	7*		1	2	3	4	5	6*	7*	
1	2	3	4					1	2	3	4				
1	2	3	4	5				1	2	3	4	5			
1	2	3	4					1	2	3	4				
1	2	3	4	5	6*			1	2	3	4	5	6*		
1	2	3	4	5				1	2	3	4				
1	2	3	4	5				1	2	3	4	5			
1	2	3	4	5				1	2	3	4				
1	2	3	4	5	6*	7*		1	2	3	4	5	6*	7*	

- 1 Baffle Filter Check
- 2 EAC Filter Check
- 3 Charcoal Filter Check
- 4 Filter Clogged
- 5 Quarterly Cleaning
- 6 Fire Suppression System
- 7 Fire Suppression System replace Fusible Links

* Inspection performed by a qualified fire equipment company.



Notes:

8. Troubleshooting

This section describes troubleshooting procedures for the Giles Electric Fryer, Model WOG-MP and WOG-MP-VH. Refer to the wiring diagram in for more detailed analysis.

8-01. Temperature Control System		
Problem	Probable Cause	Repair Procedure
FRYER WILL NOT TURN ON: No power light * -ILS model only	A. Not connected to power source.	A. Connect to power source.
	B. Bad fuse or circuit breaker.	B. Check fuse or breaker.
	C. Fuse holder cracked.	C. Replace fuse holder.
	D. Power switch bad.	D. Replace Power Switch.
	E. Improper supply voltage.	E. Connect to proper voltage source.
	F. Hood cover not closed.	F. Close Hood Cover.
	G. Fire Suppression not armed.	G. Call local Ansul Dealer to arm.
	*H. "Push and Hold to Start" button not held down for a full 5 seconds.	*H. Hold down "Push and Hold to Start" button for 5 seconds.
FRYER WILL NOT HEAT: Power light on. Heat light not on.	A. Cook/Filter Switch not in cook position.	A. Place Cook/Filter Switch in cook position.
FRYER WILL NOT HEAT: Power light on. Cook/Filter Switch in cook position. Heat light not on.	A. Thermostat set below current Oil temperature.	A. Allow Oil to cool.
	B. Drain Valve open.	B. Close Drain Valve.
	C. Thermostat faulty.	C. Replace Thermostat.
	D. Variable probe shorted or open.	D. Replace Probe.
	E. Loose wire.	E. Repair loose wire.
	F. Contactor failure.	F. Replace faulty contactor.
	G. Element bad.	G. Replace element.
	H. Selector Switch bad.	H. Replace Selector Switch.

8-01. Temperature Control System (Continued)		
Problem	Probable Cause	Repair Procedure
FRYER WILL NOT HEAT: Power light on. Selector Switch in cook position. Filter missing light on. (VH Model Only)	A. Baffle Filter missing.	A. Install Baffle Filter.
	B. Baffle Filter not installed properly.	B. Reinstall Baffle Filter.
	C. Charcoal Filter missing.	C. Install Charcoal Filter.
FRYER WILL NOT HEAT: Power light on. Selector Switch in cook position. Heat light not on. Buzzer emitting a PULSATING Tone. (VH Model only)	A. EAC shorted or bent fins.	A. Repair EAC.
	B. EAC dirty.	B. Clean EAC.
	C. EAC Power Supply faulty.	C. Replace high voltage Power Supply
	D. EAC wires shorted.	D. Remove shorted condition.
	E. Bad Contact Plate.	E. Replace Contact Plate.
	F. EAC Module faulty.	F. Replace EAC Module.
FRYER WILL NOT HEAT: Power light on. Selector Switch in cook position. High Limit light On.	A. Power surge.	A. Turn Power Switch off for 5 seconds.
	B. Plug not completely in.	B. Reconnect to power source.
	C. Oil level too low.	C. Fill to kettle oil level mark.
	D. Sticking Contactor.	D. Replace Contactor.
	E. Bad High Limit Board.	E. Replace High Limit Board.
	F. High Limit Probe short or open.	F. Replace High Limit Probe.
	G. Line spikes or noise.	G. Filter Line or remove noise source.
FRYER WILL NOT HEAT: Power light on. Selector Switch in cook position. Heat light not on. Buzzer emitting a CONTINUOUS tone. (VH Model only)	A. Charcoal Filter clogged.	A. Replace Charcoal Filter.
	B. Clogged Filter Switch bad.	B. Replace Clogged Filter Switch.
	C. Kinked Vacuum Line.	C. Remove Vacuum Line kinks.
	D. Fan running slow.	D. Check Voltage.
	E. Fan running slow.	E. Clean fan blades.

8-01. Temperature Control System (Continued)		
Problem	Probable Cause	Repair Procedure
FRYER HEATS SLOW: (slow recovery) Heat light stays on.	A. Incorrect Cooking procedures.	A. Consult Operations Manual for proper Cooking procedure.
	B. Element failing.	B. Replace bad Element.
	C. Contactor failing.	C. Replace Contactor.
	D. Loose Wire.	D. Repair Loose Wire.
	E. Low Supply Voltage.	E. Supply proper Voltage.
FRYER HEATS SLOW: (short cycling) Heat light off and on CONTINUOUSLY.	A. Low supply Voltage.	A. Supply proper Voltage.
	B. Variable probe touching element.	B. Reposition variable probe.
	C. Thermostat faulty.	C. Replace Thermostat.
OIL TEMPERATURE ERRATIC:	A. Probe bad.	A. Replace Probe.
	B. Contactor failing.	B. Replace Contactor.
	C. Thermostat faulty.	C. Replace Thermostat.
	D. Loose Wire.	D. Repair loose Wire.
OIL SMOKING:	A. Old Oil.	A. Change Oil.
	B. Over Temperature.	B. Check temperature setting.
	C. Dirty Element.	C. Clean Elements.
	D. Element failure.	D. Replace Element.
	E. Improper element voltage.	E. Supply proper Voltage.
	F. Low Oil level.	F. Keep Oil at FULL Level.

8-02. Oil Filtration System

Problem	Probable Cause	Repair Procedure
OIL NOT RETURNING TO FRY POT:	A. Cook/Filter Switch not in "Filter" position.	A. Place Selector Switch in "Filter" position.
	B. Air Leak (hose, fittings, filter paper).	B. Repair Air Leak.
	C. Pump Motor Bad.	C. Replace Pump Motor.
	D. Oil Pump Sticking.	D. Free Stuck Pump.
	E. Filter Pan contains too much sediment.	E. Remove Filter Pan and thoroughly clean.
	F. Filter Pan not assembled correctly.	F. Assemble correctly, See Section 6-02.
	G. Oil in Filter Pan below 200°F.	G. Remove Filter Pan and remove cold oil.
OIL PUMP STICKING	A. Boil Out being run through Pump.	A. Disassemble and Re-Oil Pump.
	B. Old Oil allowed to sit in Pump.	B. Run Clean Oil through Pump.

8-03. Ultimate Ventless System

UV Lamp Not Illuminated	A. Bad connection	A. Reconnect
	B. Lamp blown	B. Replace lamp
	C. Filters not installed correctly	C. Install filters
	D. Filter access cover not installed correctly.	D. Install filter access cover
	E. Bad ballast	E. Replace ballast

9. Parts List

This section lists various parts that are available for replacement on the WOG-MP and WOG-MP-VH.

9-01. Parts Ordering and Service Information

If you require assistance or need repairs, please contact your Giles representative for a service agency in your area. For further assistance, please contact the Giles Enterprises, Inc. factory at the following phone numbers:

IN THE UNITED STATES, CANADA or MEXICO

Please call [1-800-554-4537](tel:1-800-554-4537) during normal business hours, 8:00AM-5:00PM Central Time Zone. For emergency equipment repair service, after normal business hours, call 1-800-554-4537, extension 314.

IN ALL OTHER COUNTRIES

Please call [1-334-272-1457](tel:1-334-272-1457) during normal business hours, 8:00AM-5:00PM Central Time Zone; For emergency equipment repair service, after normal business hours call, 1-334-272-1457 extension 314.

INTERNET

Please visit our website on the world wide web at: www.gilesent.com.

The goal of the Giles team of professionals is to provide you with the highest quality of service and assistance. You can help us accomplish this by obtaining the following information and having it readily available when calling. The information is recorded on the Serial Plate attached to the rear of the unit.



Serial Plate information

The area below may be helpful in recording information for use as a quick reference.

Model: _____

Serial Number: _____

Phase: _____

Voltage: _____

9-02. Control Panel & Front Header

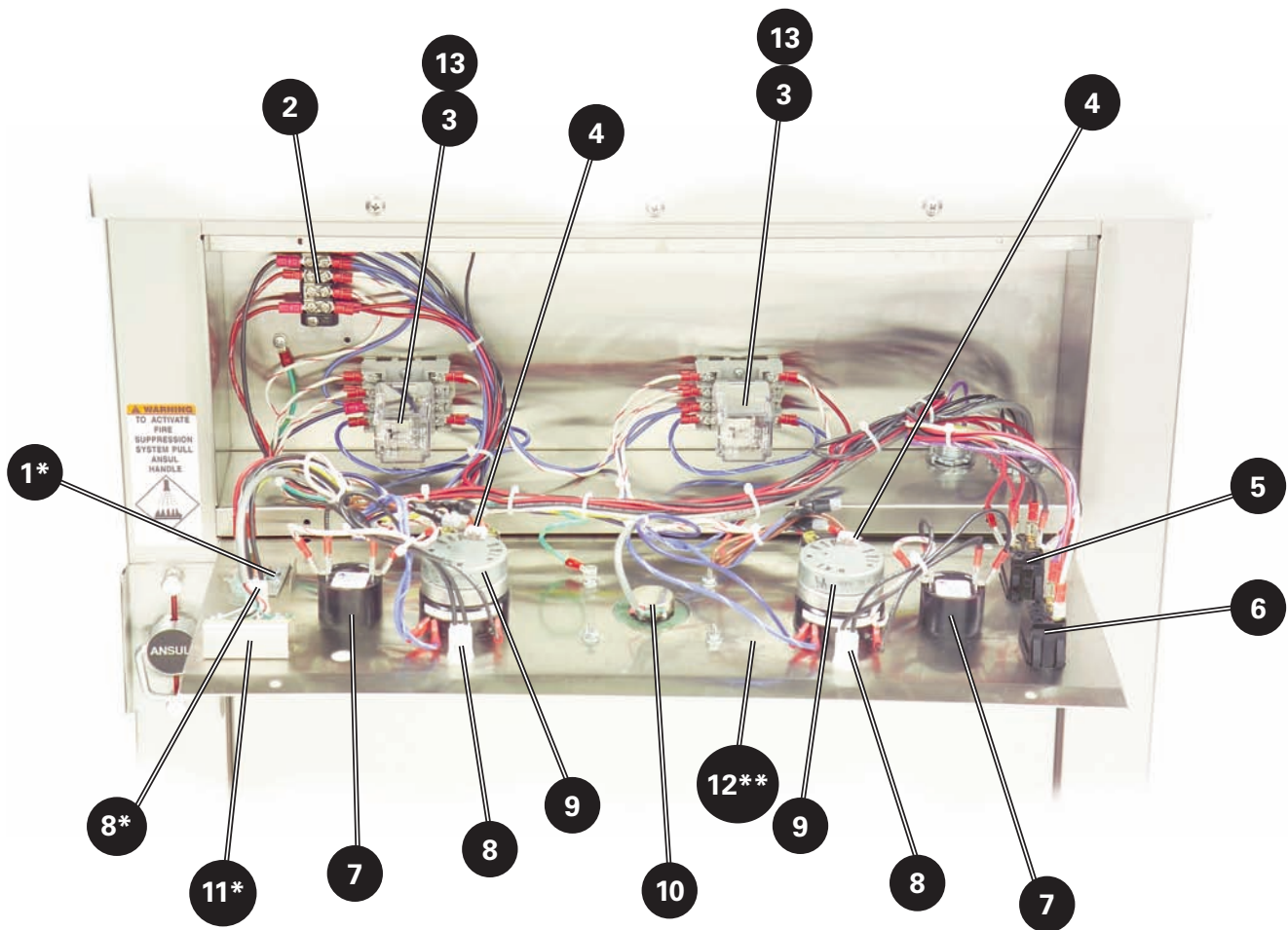

* -Ventless Hood Model only, not shown

* -Ventless Hood Model only



9-02. Parts List for Control Panel & Front Header

Item	Part No.	Qty.	Description
1	38217	1	ASSY, INDICATOR LIGHTS,208-240V
2	23751	1	TERMINAL BLOCK, MA106,6 POLE
3	21101	2	SOCKET, RELAY, 8 PIN, 300V, 10A, CR-5
4	20109	1	SWITCH, PUSH BUTTON, 250V, 10A, N.C.,RED
5	21190	1	SWITCH, ROCKER, ON-OFF, 250V, 20A, DPST
6	21189	1	SWITCH, ROCKER, ON-OFF-ON, 250V,20A,S.P.
7	23782	2	SONALERT, 250V, CONTINUOUS BEEP
8	22300	3	LIGHT, PILOT, 250V, ROUND, RED
9	20108	2	TIMER, MALLORY, MECHANICAL
10	70719	1	KIT,ANTUNES TEMP CONTROLLER,375 DEG.F
11	24209	1	LED, AIR FILTER, EAC
12	23173	1	SWITCH,PUSHBUTTON,N.O.,MOM,PLUNGER
13	21102	2	RELAY, 8 PIN, 240V COIL, 10A

9-03. Front Lower Cabinet

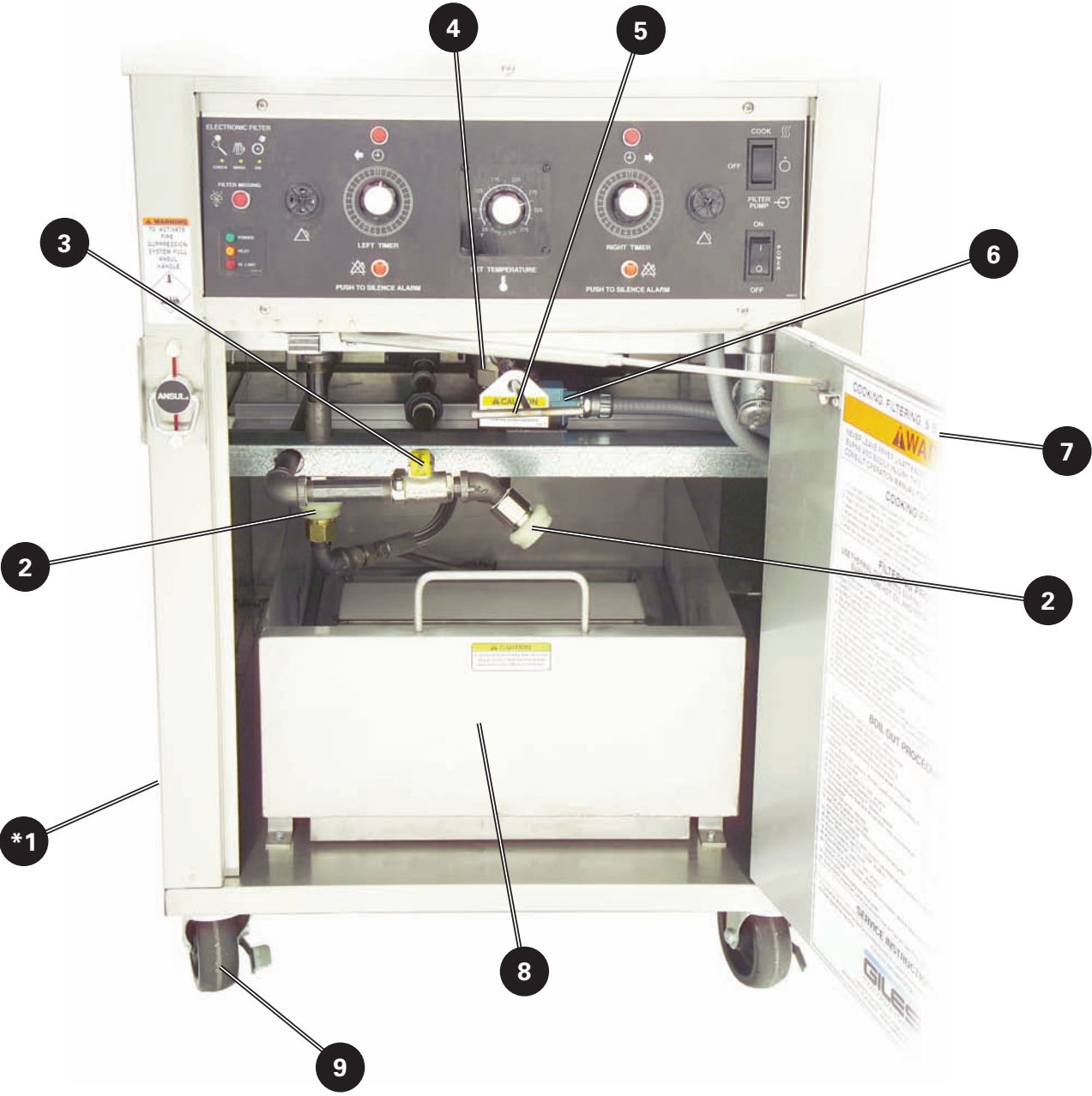

* -Not shown



9-03. Parts List for Front Lower Cabinet

Item	Part No.	Qty.	Description
1	40650	2	CASTER, RIGID, 5.0 IN, PLATE MNT
2	41900	2	COUPLING, QUICK DICONNECT, FEMALE
3	45755	1	VALVE, 3-WAY, 1/2NPT, NICKEL PLATED
4	45850	1	VALVE, BALL, 1NPT, NICKEL PLATED,DRAIN
5	30925	1	T-HANDLE, WELD ASSY
6	21157	1	SWITCH, LIMIT, 15A, 250V DRAIN SWITCH
7	30870	1	DOOR, WELD ASSY
8	36727	1	FILTER PAN ASSY
9	40700	2	CASTER, SWIVEL, 5,W/SIDE BRAKE,PLATE MNT



9-04. Rear Lower Cabinet

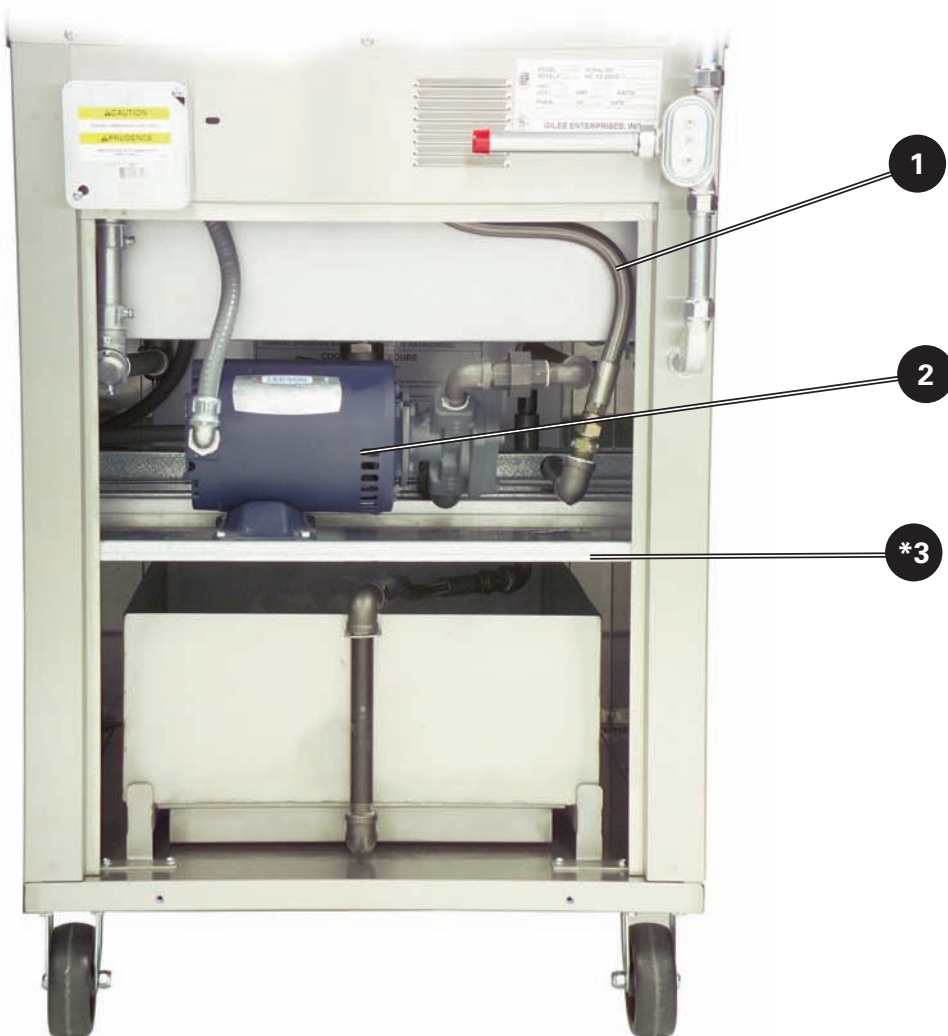

* -Not shown



9-04. Parts List for Rear Lower Cabinet

Item	Part No.	Qty.	Description
1	43302	1	HOSE, 1/2NPT X 18.000, STEEL BRAIDED
2	70912	1	PUMP/MOTOR ASSY, VIKING
3	30013	1	CAB BACK PANEL, WELD ASSY

9-05. Cooking Vat

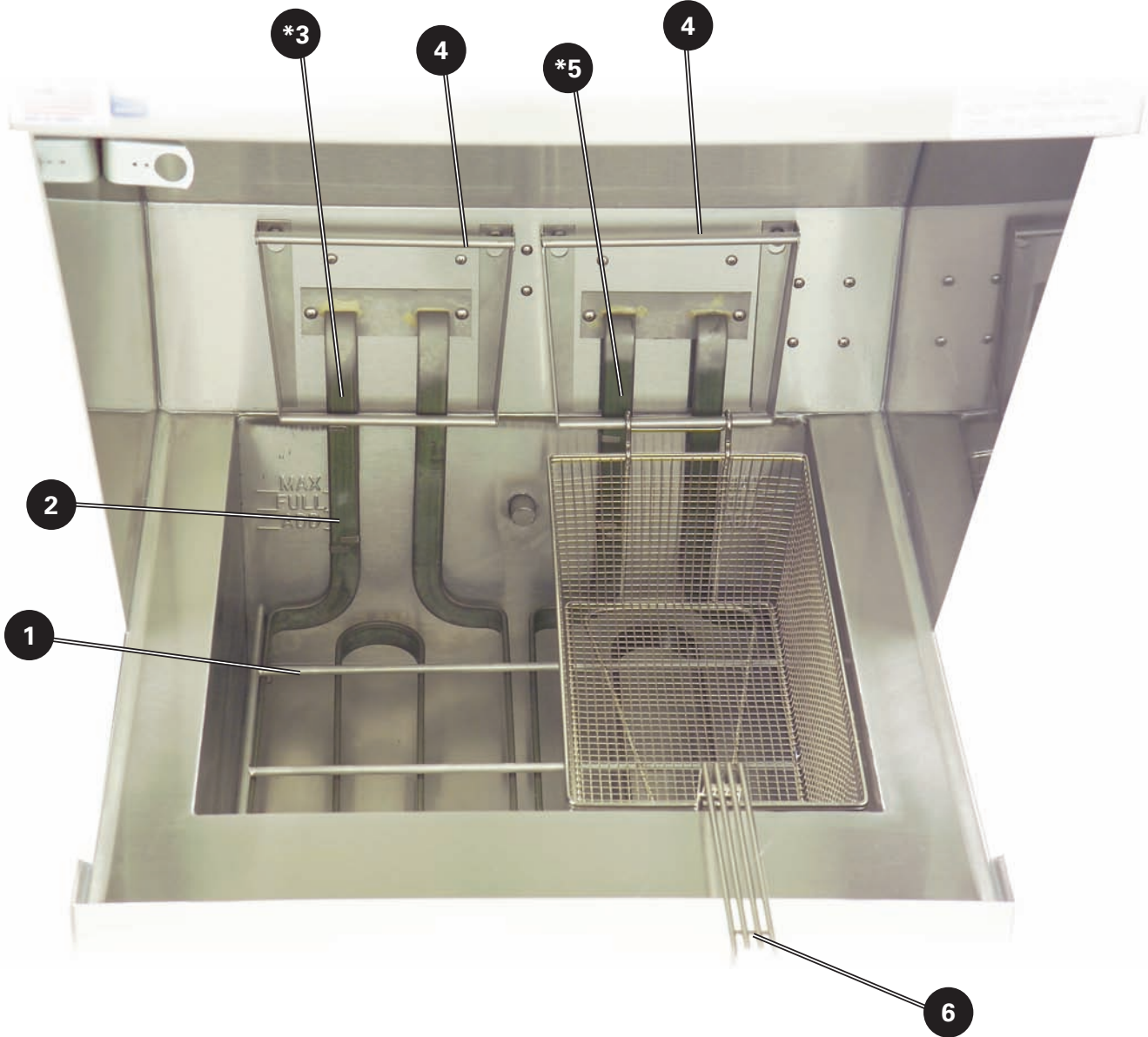

* -Not shown



9-05. Parts List for Cooking Vat

Item	Part No.	Qty.	Description
1	30815	1	BASKET RACK, WELD ASSY, WOG-MP,GRATE
2	23761	2	ELEMENT, FIREBAR, 10000W, 240V, WOG-MP
2	23760	2	ELEMENT, FIREBAR, 10000W, 208V, WOG-MP
3	21154	1	THERMOCOUPLE, 9IN., SINGLE, TYPE-J, (SAFETY)
4	30828	2	BASKET MOUNT, WELD ASSY, WOG-MP
5	21154	1	THERMOCOUPLE, 9IN., SINGLE, TYPE-J, (VARIABLE)
6	70178	2	BASKET, FRY, WOG-MP

9-06. Filter Pan

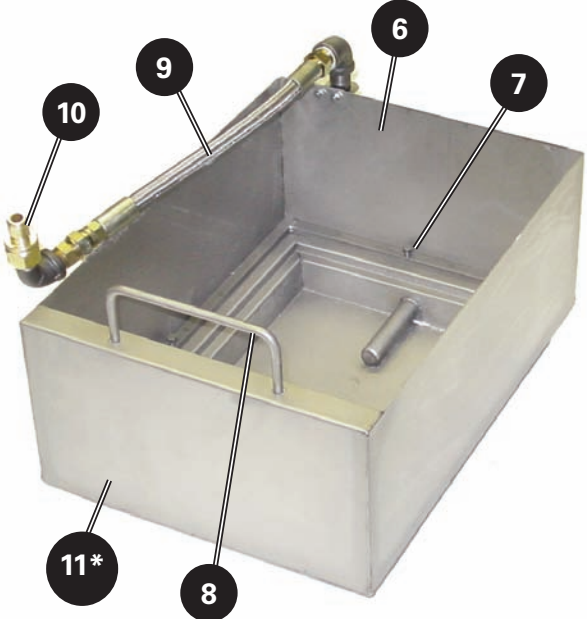
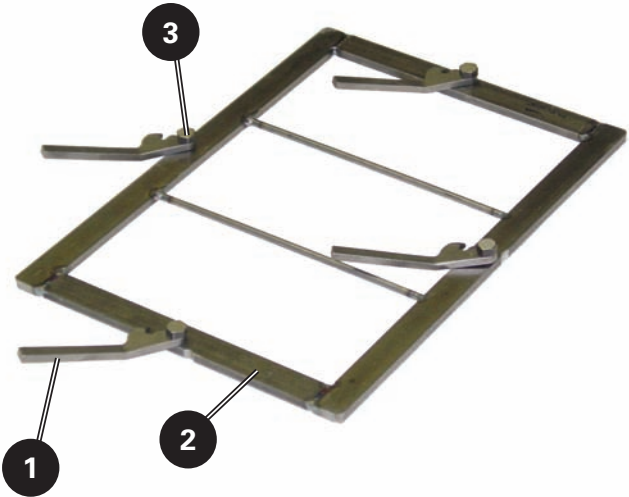
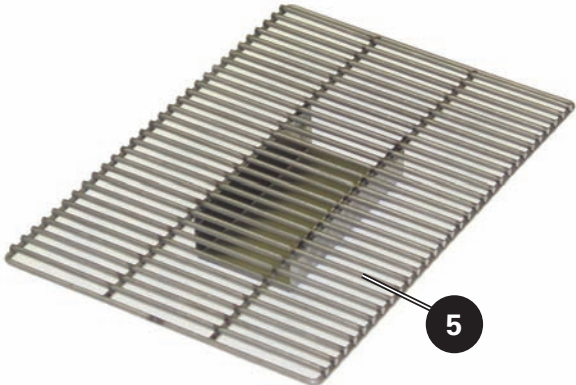

* -Complete Filter Pan includes all parts shown



9-06. Parts List for Filter Pan

Item	Part No.	Qty.	Description
1	54526	4	CASTING, LEVER,FILTER PAN,HOLDDOWN FRAME
2	30040	1	HOLD DOWN FRAME, ASSY
3	30040-4	4	STUD, FILTER PAN HOLD DOWN FRAME
4	60819	2	PAPER, FILTER, GFS, 16-1/4 X 24-1/4
5	30041	1	FILTER PAN SCREEN, WELD ASSY
6	32075	1	FILTER PAN, WELD ASSY, WOG-MP
7	30039-8	4	STUD, FILTER PAN SUPPORT FRAME
8	32075	1	FILTER PAN, WELD ASSY, WOG-MP
9	43302	1	HOSE, 1/2NPT X 18.000, STEEL BRAIDED
10	44150	1	FITTING, BRASS,MALE,1/2NPT,QUICK DISCONN
11	36727	1	FILTER PAN ASSY

9-07. Front Ventless Hood

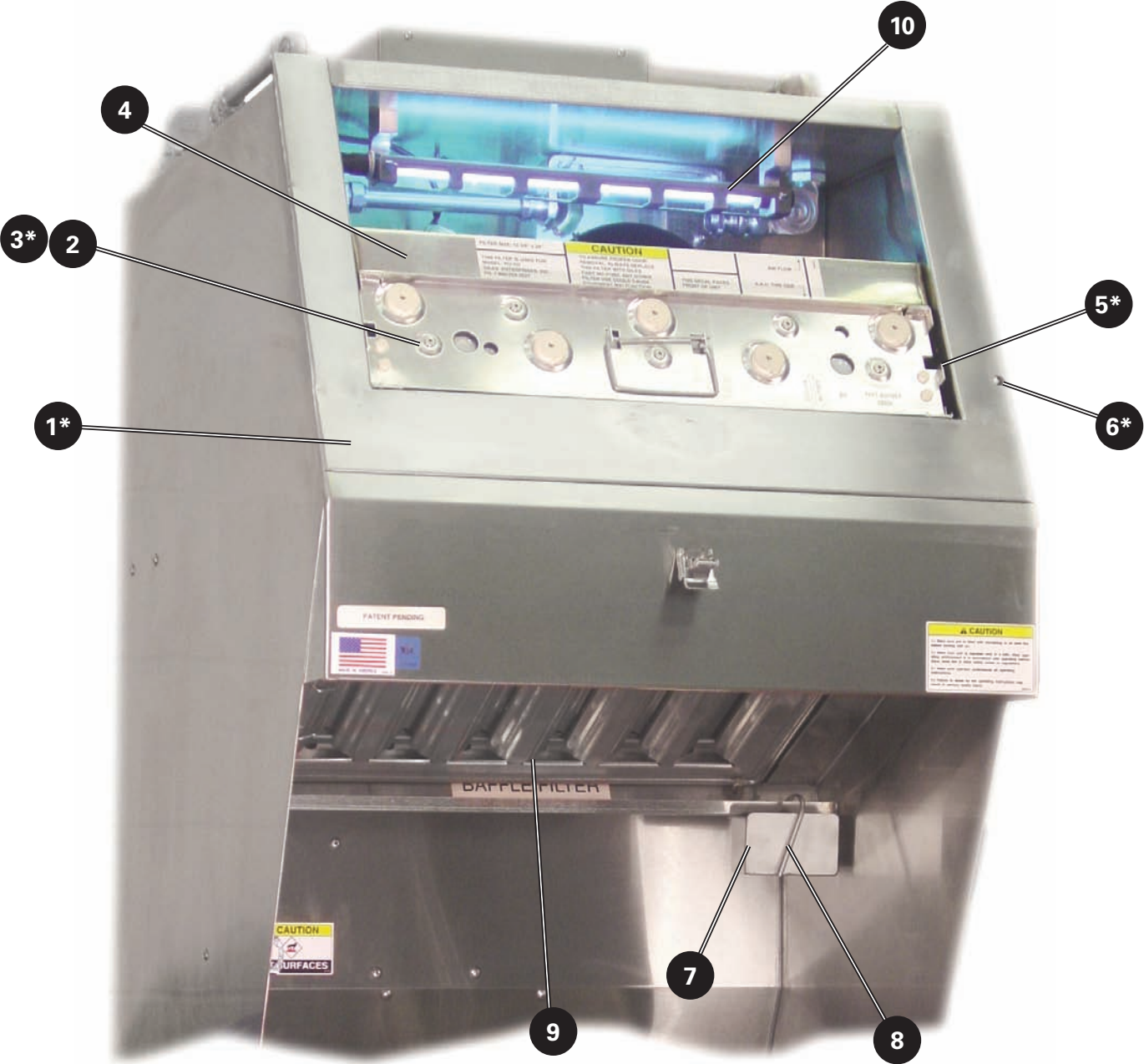

* -Not shown

9-07. Parts List for Front Ventless Hood

Item	Part No.	Qty.	Description
1	30205	1	FILTER ACCESS PANEL, WELD ASSY
2	20520	1	FILTER, EAC, 20 IN
3	21153	9	WIRE, IONIZER, 20IN EAC LARGE
4	30248	1	CHARCOAL FILTER, ASSY, 20 X 12.375 X 2
5	21125	1	BOARD, CONTACT, EAC, VH UNITS
6	23200	1	SWITCH, SNAP ACTION, ROLLER TYPE
7	30206	1	DRIP CUP, WELD ASSY
8	34750	1	PIN, DRIP CUP SAFETY
9	42300	1	FILTER, BAFFLE, 20X20, S/S, LARGE VH
10	90226	1	LAMP, ASSY, 16-IN, UV, REPLACEMENT ONLY

9-08. Rear Ventless Hood

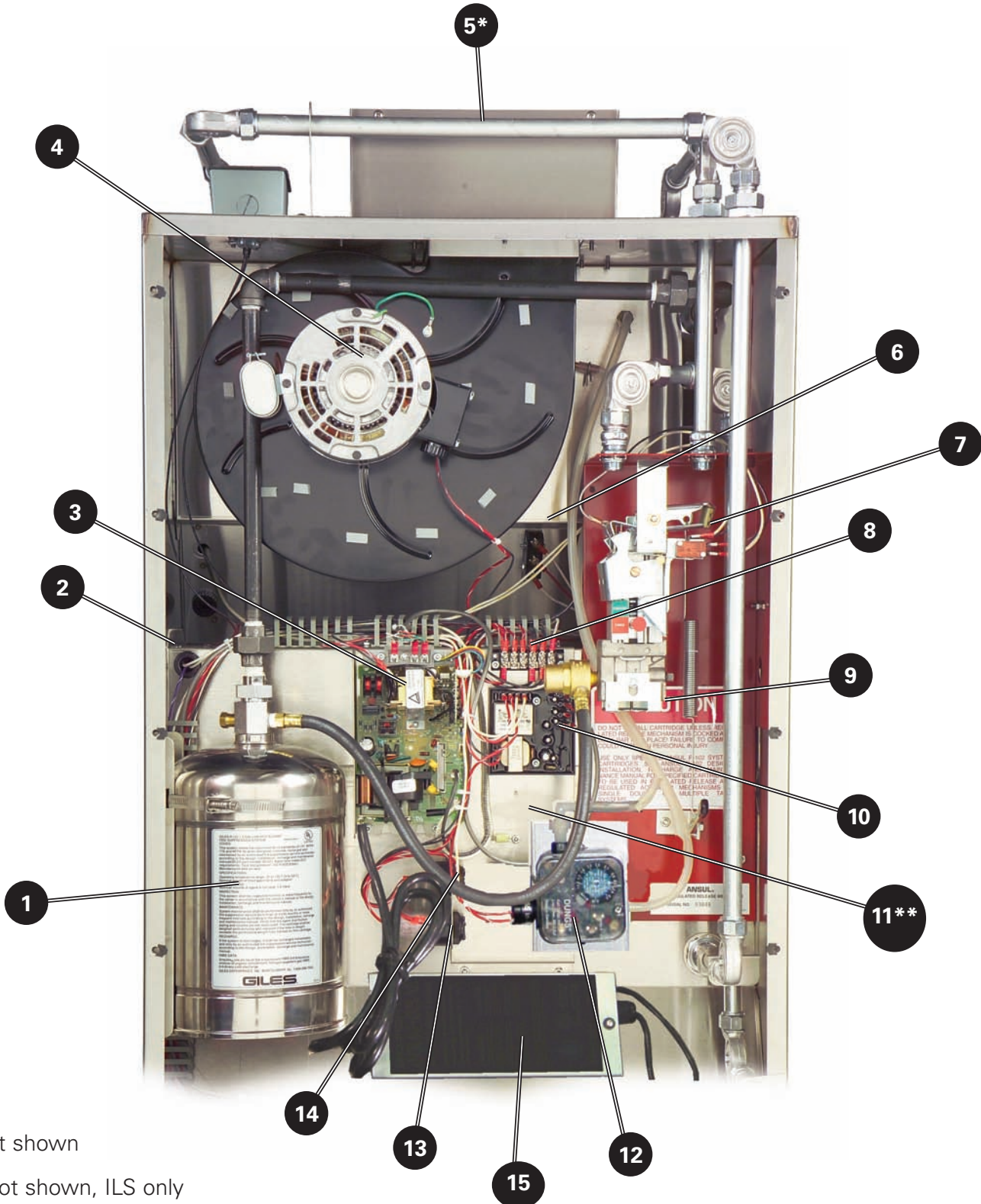

* -Not shown

** -Not shown, ILS only



9-08. Part List for Rear Ventless Hood

Item	Part No.	Qty.	Description
1	40811	1	TANK, 1.5 GAL STAINLESS STEEL
2	31139	1	BAFFLE FILTER SWITCH, ASSY
3	24208	1	POWER SUPPLY, W/DRIVER BRD, 208-240V,EAC
4	33589	1	BLOWER,ASSY,CF-400VH/WOG-MP-VH
5	46125	1	DAMPER, FIRE, 10 X 10, 285 DEG LINK
6	24237	1	SWITCH, PLUNGER, 250V, 15A
7	20002	2	SWITCH, ANSUL, SHUTDOWN/ALARM, 15A, 120V
8	23751	1	TERMINAL BLOCK, MA106,6 POLE
9	40132	1	ASSY., OEM RELEASE/BRACKET,FIRE SUPPRESS
10	23776	1	MODULE, AIR FILTER, ALARM AND SHUTDOWN
11	21174	1	RELAY, 30A, 240V, 2 POLE
11	21191	1	RELAY, 30A, 208V, 2 POLE
12	20390	1	SWITCH, VACUUM, ADJUSTABLE
13	23782	1	SONALERT, 250V, CONTINUOUS BEEP
14	22950	1	SONALERT, 250V, INTERMITTENT
15	20373	1	BALLAST/LAMP ASSY



Notes:



Giles Enterprises, Inc.

2750 Gunter Park Drive West • Montgomery, Al 36121-0247 USA
(334) 272-1457 • Service Hotline 1-800-554-4537 (USA & Canada Only) • FAX (334) 272-3518 • www.gilesent.com

Form No. 60198 (Release date: 4/98)(Revision Date: 07/31/09)(Rev D)