

# Master Series Full-Size Electric Convection Ovens

## Installation, Operation and Maintenance Manual

This manual is updated as new information and models are released. Visit our website for the latest manual.



MCO-ES-20M

### models

MCO-ES-10S  
MCO-ED-10S  
MCO-ES-20S  
MCO-ED-20S  
MCO-ES-10M  
MCO-ED-10M  
MCO-ES-20M  
MCO-ED-20M

Original Document



# SAFETY NOTICES

**WARNING:**

This product contains chemicals known to the state of California to cause cancer and/or birth defects or other reproductive harm. Installation and servicing of this product could expose you to airborne particles of glass wool/ceramic fibers. Inhalation of airborne particles of glass wool/ceramic fibers is known to the state of California to cause cancer.

**FOR YOUR SAFETY:  
DO NOT STORE OR USE GASOLINE  
OR OTHER FLAMMABLE VAPORS OR  
LIQUIDS IN THE VICINITY OF  
THIS OR ANY OTHER  
APPLIANCE**

**WARNING:  
IMPROPER INSTALLATION, ADJUSTMENT,  
ALTERATION, SERVICE OR MAINTENANCE  
CAN CAUSE PROPERTY DAMAGE, INJURY,  
OR DEATH. READ THE INSTALLATION,  
OPERATING AND MAINTENANCE  
INSTRUCTIONS THOROUGHLY  
BEFORE INSTALLING OR  
SERVICING THIS EQUIPMENT**

PLEASE READ ALL SECTIONS OF THIS MANUAL AND RETAIN FOR FUTURE REFERENCE.

THIS PRODUCT HAS BEEN CERTIFIED AS COMMERCIAL COOKING EQUIPMENT AND MUST BE INSTALLED BY PROFESSIONAL PERSONNEL AS SPECIFIED.

INSTALLATION AND ELECTRICAL CONNECTION MUST COMPLY WITH CURRENT CODES:  
IN CANADA - THE CANADIAN ELECTRICAL CODE PART 1 AND / OR LOCAL CODES.  
IN USA – THE NATIONAL ELECTRICAL CODE ANSI / NFPA – CURRENT EDITION.

ENSURE ELECTRICAL SUPPLY CONFORMS WITH ELECTRICAL CHARACTERISTICS SHOWN ON THE RATING PLATE.

Users are cautioned that maintenance and repairs must be performed by a Garland authorized service agent using genuine Garland replacement parts. Garland will have no obligation with respect to any product that has been improperly installed, adjusted, operated or not maintained in accordance with national and local codes or installation instructions provided with the product, or any product that has its serial number defaced, obliterated or removed, or which has been modified or repaired using unauthorized parts or by unauthorized service agents.

For a list of authorized service agents, please refer to the Garland web site at <http://www.garland-group.com>.

The information contained herein, (including design and parts specifications), may be superseded and is subject to change without notice.

## **Power Failure**

In the event of a power failure, no attempt should be made to operate this oven.







# TABLE OF CONTENTS

<b>SAFETY NOTICES.....</b>	<b>2</b>	<b>COOK AND HOLD .....</b>	<b>17</b>
<b>GENERAL INFORMATION .....</b>	<b>5</b>	<b>CLEANING AND MAINTENANCE.....</b>	<b>18</b>
Model Numbers .....	5	Break-In Period .....	18
Warranty .....	5	Exterior Cleaning .....	18
Serial Plate Location.....	5	Interior Cleaning .....	18
Accessories .....	5	Fan Area Maintenance .....	18
<b>DIMENSIONS AND SPECIFICATIONS, MCO</b>		Motor Care .....	18
<b>ED/ES 10/20 .....</b>	<b>6</b>		
<b>DIMENSIONS AND SPECIFICATIONS, MCO</b>			
<b>ED/ES 10/20 S.....</b>	<b>7</b>		
<b>INSTALLATION .....</b>	<b>8</b>		
Entry Clearance .....	8		
Installation Clearance .....	8		
Installation of Double Deck Models .....	8		
Electrical Connections.....	9		
<b>OPERATING INSTRUCTIONS.....</b>	<b>10</b>		
Master 200 Solid State Control			
with Electromechanical Timer .....	10		
Electronic Control .....	11		
Start Up.....	11		
Press and Go Menu.....	11		
Manual Mode .....	12		
Operating The Controls.....	13		
Cook-N-Hold Operation .....	13		
Settings Mode .....	13		
<b>PERFORMANCE RECOMMENDATIONS AND</b>			
<b>GENERAL SAFETY PRECAUTIONS.....</b>	<b>14</b>		
<b>PROBLEM/SOLUTIONS .....</b>	<b>15</b>		
<b>COOKING GUIDE.....</b>	<b>16</b>		

THIS PAGE INTENTIONALLY LEFT BLANK

# GENERAL INFORMATION

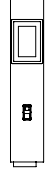
## Model Numbers

Model	Standard Depth	Deep Depth	Single Deck	Double Deck	Digital Control	Master <sup>200</sup> Control
						
MCO-ES-10S	✓		✓			✓
MCO-ED-10S		✓	✓			✓
MCO-ES-20S	✓			✓		✓
MCO-ED-20S		✓		✓		✓
MCO-ES-10M	✓		✓		✓	
MCO-ED-10M		✓	✓		✓	
MCO-ES-20M	✓			✓	✓	
MCO-ED-20M		✓		✓	✓	

## Warranty

Visit [www.Garland-Group.com](http://www.Garland-Group.com) to view or download a copy of your warranty.

## Serial Plate Location

When corresponding with the factory or your local authorized factory service center regarding service problems or replacement parts, be sure to refer to the particular unit by the correct model number (including the prefix and suffix letters and numbers) and the warranty serial number.

The serial plate is located in the upper right corner of the left body panel.



## Accessories

- Stainless steel open base with rack guides and shelf (in lieu of 25-inch legs) for extra rack/pan storage, single deck oven only

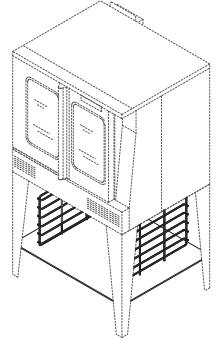

- Swivel Casters (set of 4) with front brakes



- Extra oven rack



- Removable stainless steel drip pan

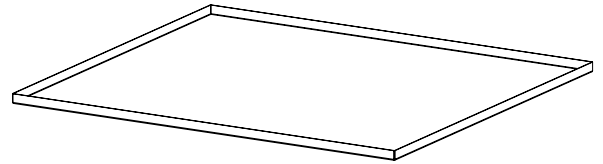

# DIMENSIONS AND SPECIFICATIONS, MCO ED/ES 10/20

Model**	Total kW Load	Nominal Amperes Per Line (includes 0.6 HP fan motor)																
		208V/1Ph	240V/1Ph	208V/3Ph			240V/3Ph			460V/3Ph			380V/3Ph**			415V/3Ph		
				X	Y	Z	X	Y	Z	X	Y	Z	X	Y	Z	X	Y	Z
MCO-ES-10M	10.4	50	43	30	30	28	26	26	24	14	14	13	15	13	13	16	14	14
MCO-ED-10M	10.4	50	43	30	30	28	26	26	24	14	14	13	15	13	13	16	14	14

\*\*Total kW rating for 380/3 phase models is 9.0

Model	Interior Dimensions (per oven)			Exterior Dimensions			Ship Info.	
	W:In(mm)	H:In(mm)	D:In(mm)	W:In(mm)	H:In(mm)	D:In(mm)	Lbs./Kg	Cu. Ft.
MCO-ES-10M	29 (736)	24 (610)	24 (610)	38 (965)	57-1/2 (1461)	41-1/4 (1048)	515/230	64
MCO-ES-20M	29 (736)	24 (610)	24 (610)	38 (965)	70-1/2 (1791)*	41-1/4 (1048)	1030/465	128
MCO-ED-10M	29 (736)	24 (610)	28 (711)	38 (965)	57-1/2 (1461)	44-1/2(1130)	545/245	64
MCO-ED-20M	29 (736)	24 (610)	28 (711)	38 (965)	70-1/2 (1791)*	44-1/2(1130)	1090/490	128

\* Height with legs or with standard casters. Height with low profile casters (double deck) is 68-1/2" (1740mm).

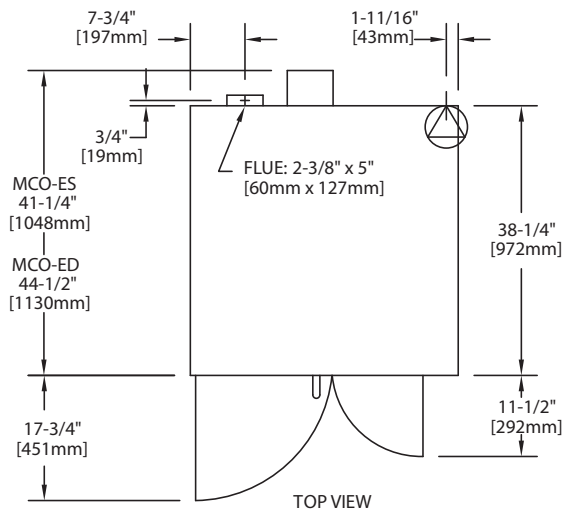

Standard electrical specifications include motor requirements. 0.6 HP, 2-speed motor, 1430/930 and 1670/1120 RPM, 60/50 Hz.

**NOTE:** Double deck ovens are provided with individual supply connections.

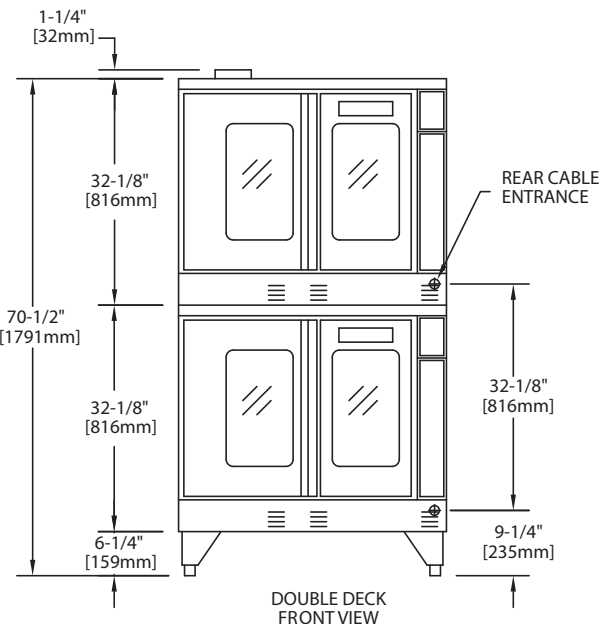
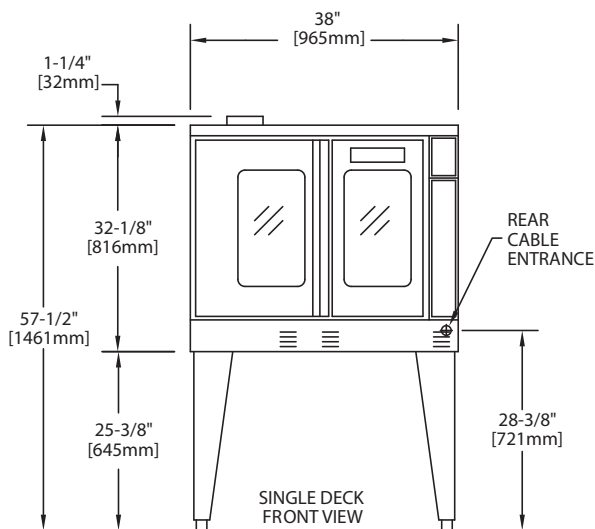

# DIMENSIONS AND SPECIFICATIONS, MCO ED/ES 10/20 S

Model	Interior Dimensions (per oven)			Exterior Dimensions			Ship Info.	
	W:ln(mm)	H:ln(mm)	D:ln(mm)	W:ln(mm)	H:ln(mm)	D:ln(mm)	Lbs./Kg	Cu Ft
MCO-ES-10S	29(436)	24(610)	24(610)	38(965)	57-1/2(1416)	41-1/4 (1048)	515/230	64
MCO-ES-20S	29(436)	24(610)	24(610)	38(965)	70-1/2(1791)*	41-1/4 (1048)	1030/465	128
MCO-ED-10S	29(436)	24(610)	28(711)	38(965)	57-1/2(1416)	44-1/2(1130)	545/245	64
MCO-ED-20S	29(436)	24(610)	28(711)	38(965)	70-1/2(1791)*	44-1/2(1130)	1090/490	128

\* Height with or without standard casters. Height with low profile casters (double deck) is 68-1/2" (1740mm).

Model**	Total kW Load	Nominal Amperes Per Line (includes 0.6 HP fan motor)													
		208V/1Ph		240V/1Ph			208V/3Ph			240V/3Ph			460V/3Ph		
		X	Y	Z	X	Y	Z	X	Y	Z	X	Y	Z		
MCO-ES-10S	10.4	50	43	30	30	28	26	26	24	14	14	13			
MCO-ED-10S	10.4	50	43	30	30	28	26	26	24	14	14	13			

\*\* NOTE: Double deck ovens are provided with individual supply connections

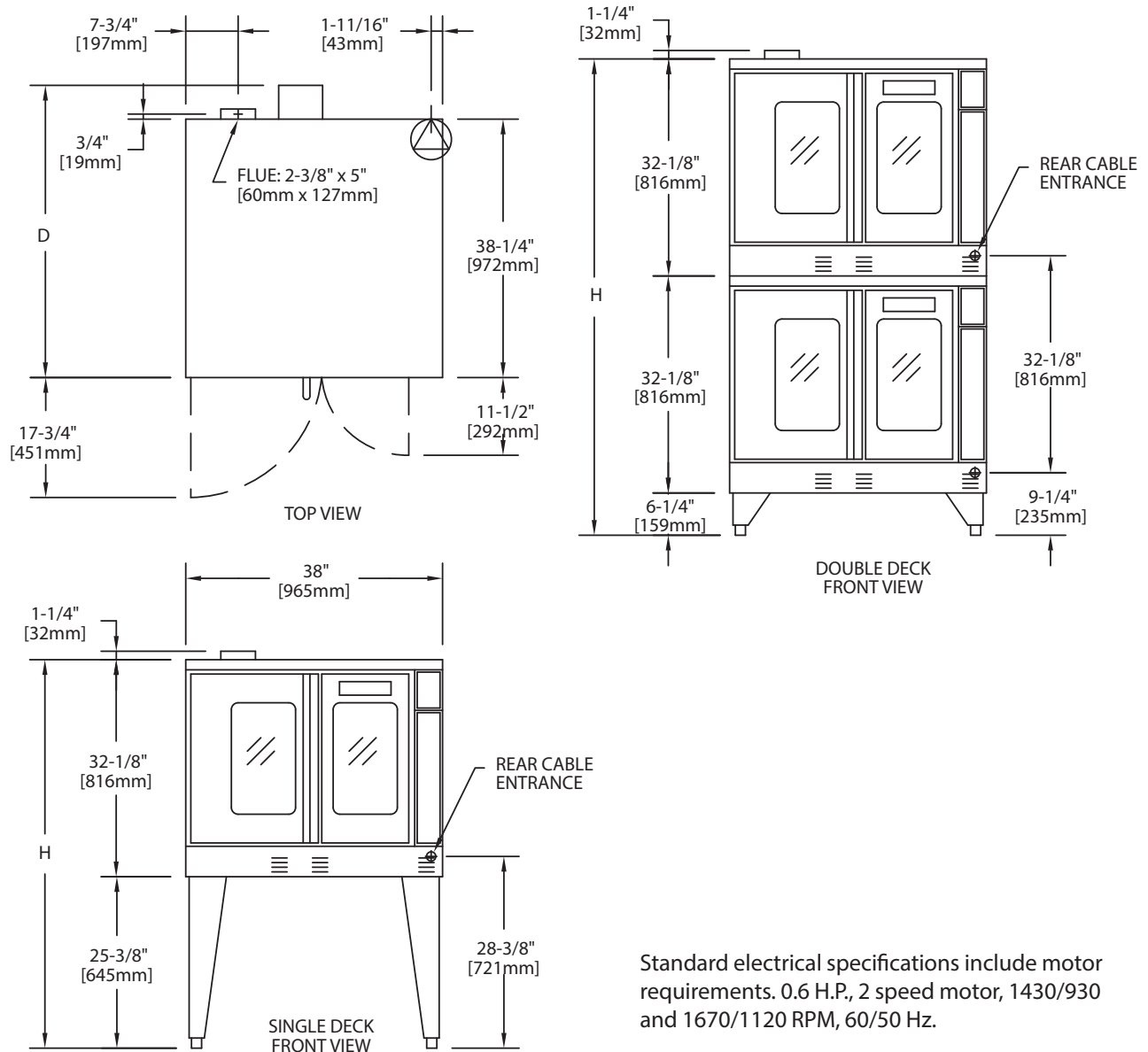

Standard electrical specifications include motor requirements. 0.6 H.P., 2 speed motor, 1430/930 and 1670/1120 RPM, 60/50 Hz.

# INSTALLATION

## Entry Clearance

- Crated: 47" (1194mm)
- Uncrated: 32-1/2" (826mm)

## Installation Clearance

NOTE: Always provide adequate clearance for maintenance and operation.

- Installation adjacent to combustible and non-combustible wall, minimum clearance:

	Left Side	Control Side	Rear
Single-Deck	1" (26 mm)	1" (26 mm)	3" (77 mm)
Double-Deck	1" (26 mm)	2" (51 mm)	3" (77 mm)

- Installation near high heat producing equipment, minimum clearance:

	Left Side	Control Side	Rear
Single-Deck	1" (26 mm)	6" (153 mm)	3" (77 mm)
Double-Deck	1" (26 mm)	6" (153 mm)	3" (77 mm)

### Notice

Avoid installing ovens near equipment, such as char-broilers or fryers, which generate high heat and high grease laden air.

- Clearance for Service (recommendation):

	Control Side, minimum
Single-Deck	12" (305 mm)
Double-Deck	12" (305 mm)

NOTE: Install units with casters in very tight locations for ease of service.

**IMPORTANT** Large objects should not be placed in front of this oven, which would obstruct the airflow through the front. Objects should not be placed on the main top rear of the oven while in use because this could obstruct the venting system. Install ovens where side body perforated panels or control sections do not get sprayed with water wash down spray hoses.

## Installation of Ovens Equipped with Casters

- A. For an appliance equipped with casters, the installation shall be made with a connector that complies with the Standard for Connectors for Movable Appliances, ANSI Z21.69. Adequate means must be provided to limit the movement of the appliance without depending on the connector wiring.
- B. The front casters of the unit are equipped with brakes to limit the movement of the oven without depending on the connector wiring to limit the appliance movement.
- C. A restraint can be attached to the unit. If the restraint is disconnected, be sure to reconnect the restraint after the oven has been returned to its originally installed position.

## Installation of Double Deck Models

- A. Position insert in bottom leg opening and tap insert up into leg until it seats at collar. Attach six inch (6") legs to lower oven section. Raise unit or lay on its left side. Place the front legs on the oven so as to line up with four (4) attaching bolt holes. Secure leg to oven frame using (4) 3/8-16 x 3/4 bolts and washers provided. Repeat at rear of unit.
- B. Remove lower front cover of top deck (located under oven doors). Raise top deck into place and line up body sides and back of the unit. Fasten the rear of the units together, with the stacking bracket using (6) 1/4-20 machine screws, lock washers and nuts, (provided).
- C. Install the interconnecting flue parts, carefully following the instructions contained in the stacking kit. Pay particular attention to the type of ovens you are stacking and be sure to follow the corresponding instructions.
- D. Check leveling of unit four (4) ways (using a common carpenter's level on the rack inside the oven).
- E. Maintain clearance from combustibles.

**CAUTION:** Disconnect both ovens from electrical supply before servicing to protect against shock!

# INSTALLATION Continued

## Electrical Connections

Before attempting the electrical connection, the rating plate should be checked to ensure that the unit's electrical characteristics and the supply electrical characteristics agree.

Installation of the wiring must be made in accordance with U.L. 197 Commercial Electric Cooking Appliance Standards, Local and/or National Electrical Code, ANSI/NFPA 70-1990, or the Canadian Electrical Code, CSA C22.2 as applicable.

1. Switch panel size
2. Overload protection
3. Wire type
4. Wire size
5. Temperature limitations of the wires
6. Method of connection (Cable, Conduit, etc.)

The service line will enter through the rear of the unit and is to be connected to the terminal block (see diagram). The terminal block is accessed by removing the lower front cover. Removal of the body side is not necessary. Install a main disconnect switch and a separate fuse or breaker with this appliance. Use a sufficient length of flexible conduit between the main disconnect switch and the appliance so unit can be moved for service.

**Input voltage and phasing must match the units voltage and phasing.** Wiring diagram is attached to the main back of each oven. Visually check all electrical connections. Energize electric service to units.

The oven is wired per original factory order. If it is necessary to change to single-phase or three-phase, please refer to kit part number [4533009](#).

Service and unit voltage must agree.

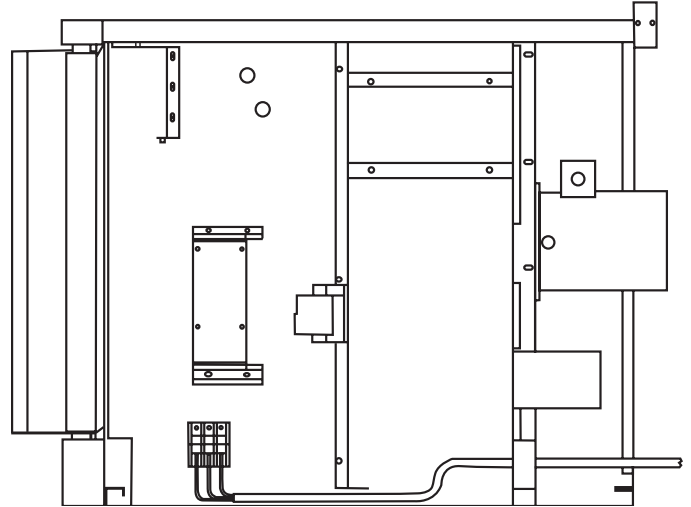

# OPERATING INSTRUCTIONS

## Master 200 Solid State Control with Electromechanical Timer

### Modes

#### In Off Mode

When the oven is off, there are no lights or indicators.

#### Start Up

Press the COOK/OFF/COOL DOWN rocker switch to the

“COOK” position. The green lamp will light indicating the oven is powered in cook mode.

The oven will begin to heat to the temperature set on the thermostat dial. The amber lamp will light indicating the heat is active. As the heat cycles on and off to maintain the set temperature this light will go on and off accordingly.

The door must be closed for the oven to operate in cook mode. Opening the door will cause the heat to stop and the motor and fan will shut off. This is a safety feature.

#### Fan Speed

The fan speed can be either high (1670RPM) or low (1430RPM). The fan speed is controlled by the left rocker switch marked high and low.

#### Lights

The oven lights are activated by pressing the light switch on the control panel. This is a momentary switch and the lights will stay lit as long as this button is held in the on position. Lights will work whenever there is electrical power connected to the oven.

#### Cool Down

Pressing the COOK/OFF/COOL down rocker switch to the COOL DOWN position activates the fan and motor to cool the oven cavity. The door must be open slightly for the fan and motor to start. The heat is not active in this mode.

Optimal cool down will be achieved with the door open slightly. Opening the door too far will shut the fan and motor off. This is a patented safety feature.

Pressing the button to the OFF position cancels the cool down and turns the oven off.

#### Temperature

The temperature range is from 150° to 500°F (66°C to 260°C) is controlled by rotating the temperature dial and aligning the indicator to the desired temperature.

#### Timer

The timer is set by rotating the dial clockwise aligning the indicator to the desired time cycle. The timer will count down from 2 minutes to 60 minutes. At the end of the timing cycle the buzzer will sound. The buzzer is turned off by rotating the dial counter clockwise to the off position,

NOTE: The timer does not control heating

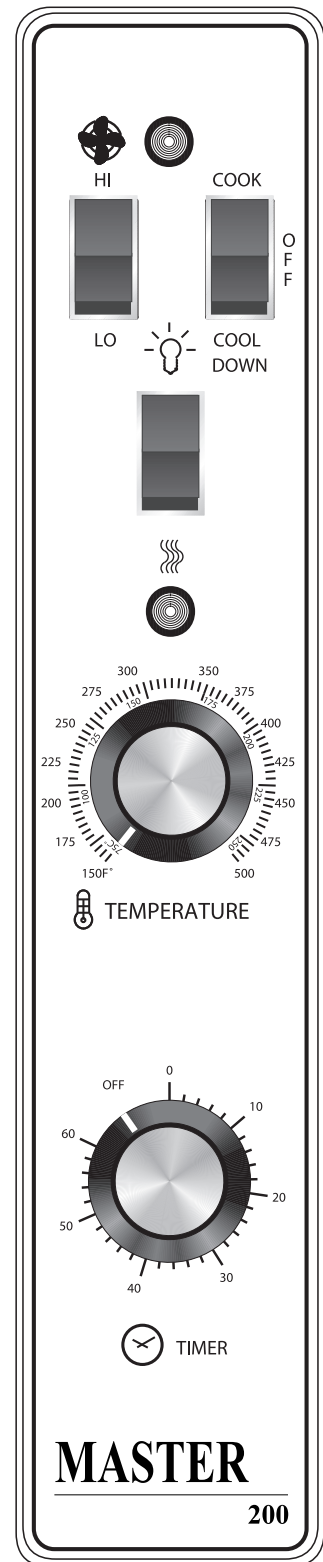

# OPERATING INSTRUCTIONS

## Electronic Control

### Start Up

When the controller is off the display will be blank. Pressing the main power switch ON will activate the controller and the splash screen (photo 1) displaying the software version and then the home screen (photo 2), will appear on the user interface. The home screen displays the four main icons of the control - the **Press and Go Menu** (square pattern) in the upper left, **Settings Mode** (gear cog) in the lower left, **Manual Mode** (chef's hat) in the upper right and the **Pause for Cleaning** (hand and cloth) button in the lower right.

Note that If the door is opened during a cooking mode, the fan and heat will stop, the interior light comes on, the control will pause and the display will indicate **door is open symbol** (see photo 3) until the door is closed. *This is a patented safety feature.* This period of pause allows time for removing product and restarting the cook cycle.

If one opens the door slightly for more than three seconds the oven will enter a **Cool Down** mode and deactivate the heat and turn the fan on high until the oven cavity temperature drops below 150°F (66°C). The Cool down will operate when the door is opened slightly (at least five degrees). Optimal cool-down will be achieved with the door open slightly. When the door opens wider, the Cool Down mode will deactivate and the display will indicate Door Open (Photo 3). This is a patented safety feature. Cool Down is not active during a cook cycle.



Photo 1

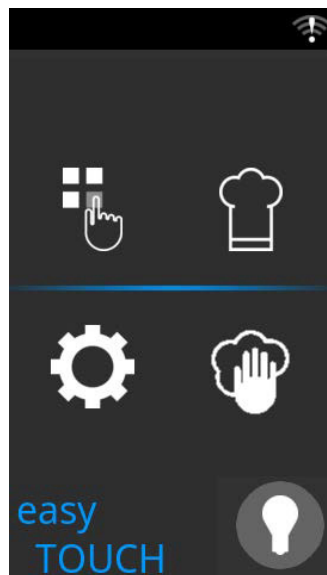

Photo 2



Photo 3

### Press and Go Menu (square pattern)

Allows quick access to existing recipes (see photo 7).

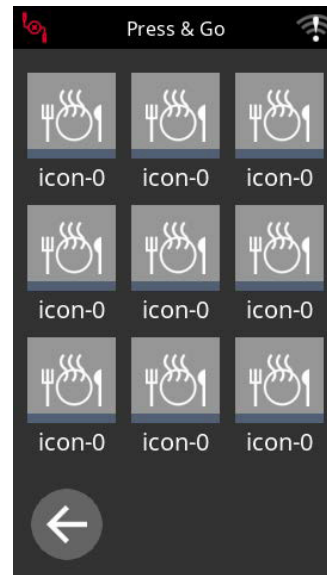

Photo 7

One need only select the desired icon.

# OPERATING INSTRUCTIONS Continued

## Manual Mode (chef's hat)

- Cook temperature (photo 5)
- Low or high fan speed or fan pulse mode whereby the fan will pulse on and off when the oven is in holding mode. (fan symbol photo 4 and 8)
- Set main cook timer (24 hour timer) (photo 8)
- Set secondary cook timer (24 hour timer) to allow for different cook times for different rack positions (photo 6)
- Turn interior light on/off (light symbol photo 4 and 8)
- Select Cook & Hold temperature (temperature appears in red -see photo 4)



Photo 4

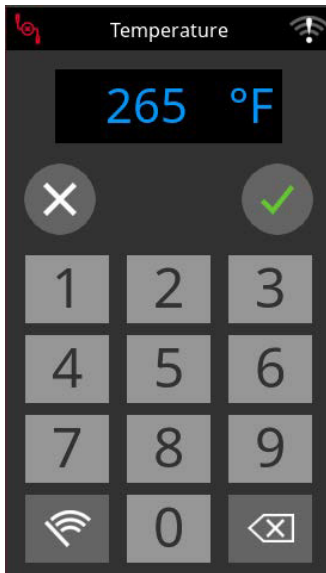

Photo 5

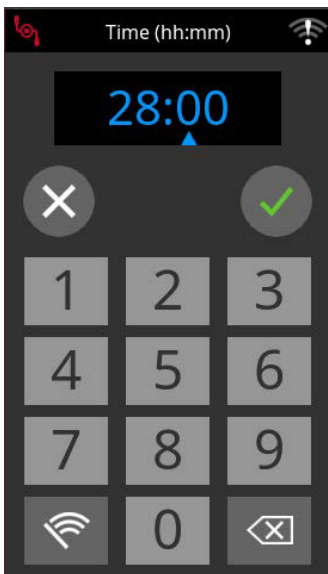

Photo 6



Photo 8

## Manual Mode cont'd.

- Program/Save recipes (photo 13 and 14)
- Select one of nine default recipes (photo 15)
- Change icons and colour (photo 15)

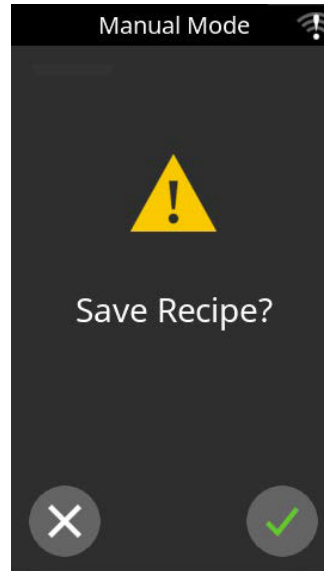

Photo 13



Photo 14

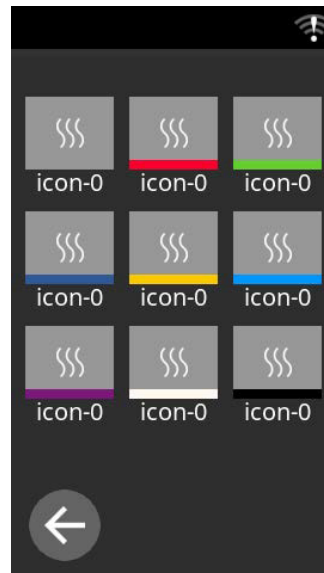

Photo 15

# OPERATING INSTRUCTIONS Continued

## Operating the Controls

Setting the cook temperature (from 150 deg. F to 500 deg. F (65 deg. C to 260 deg. C)) and time are done in the same manner (see photos 5 and 6).

When the timing cycle is started the display will count down from the Set time in minutes and seconds. Note that an alarm will sound when the set point temperature is reached and the cook time is completed.

## Cook-N-Hold Operation

Pressing the **Cook-N-Hold** symbol (see photo 4 - thermometer symbol next to light bulb) activates the Cook-N-Hold mode. The display will show the hold temperature in red. At the end of the cook cycle, an audible alarm will sound and the display will change to count "up" the time the oven is on hold. The oven will switch to the programmed hold temperature. The timer will sound the alarm again after the hold time has elapsed.

Setting the cook temperature, hold temperature and time are done in the same manner (see photos 5 and 6). The desired temperature is shown on the display.

Pressing the enter symbol will start the timing cycle.

## SETTINGS MODE (Gear Wheel)

-To enter the Settings screen a password must be keyed in from the key pad (see photo 9). The **Settings Mode** allows one to (see photo 10):

- Select deg. F or deg. C
- Select ECO Mode Temperature
- Select Cook & Hold Temperature
- Select Alarm Volume
- Perform software updates via USB (accessibility to technicians only)

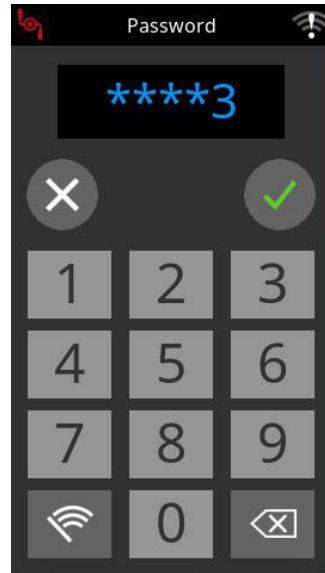

Photo 9

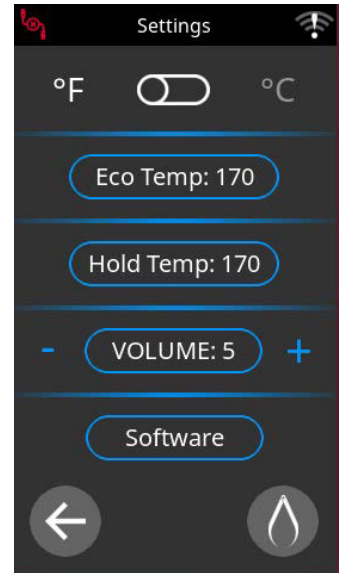

Photo 10

## CLEANING MODE (Hand & Cloth - photo 11)

-In the cleaning mode the screen remains frozen for seven seconds to allow for cleaning between operators (see photo 12)

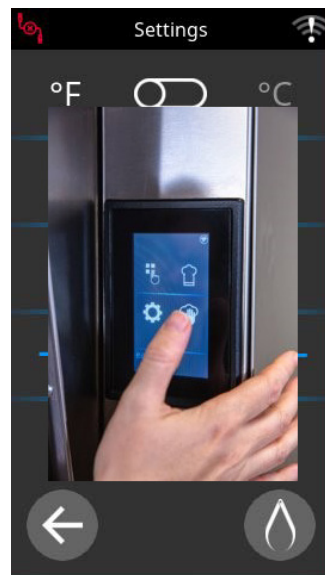

Photo 11

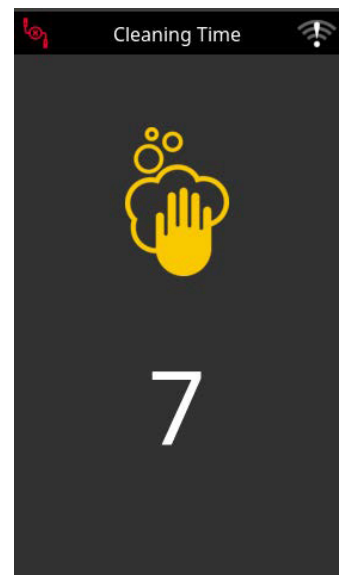

Photo 12

# PERFORMANCE RECOMMENDATIONS AND GENERAL SAFETY PRECAUTIONS

1. Preheat oven thoroughly (approx. 20 minutes) before use.
  2. As a general rule, temperature should be reduced 25° to 50° from that used in a standard/convection oven. Cooking time may also be shorter, so we suggest closely checking the first batch of each product prepared.
  3. Use the chart of suggested times and temperatures as a guide. These will vary depending upon such factors as size of load, temperature, and mixture of product (particularly moisture) and density of product.
  4. Keep a record of the times, temperature, and load sizes you establish for various products. Once you have determined these, they will be similar for succeeding loads.
  5. When practical, start cooking the lowest temperature product first and gradually work up to higher temperatures.
  6. If you find that your previous temperature setting is more than 10° higher than needed for succeeding loads, COOL DOWN to reach the desired temperature before setting a new cooking temperature.
  7. When loading oven, work as quickly as possible to prevent loss of heat.
  8. Oven will continue to heat even though the timer goes off. Product should be removed from the oven as soon as possible to avoid over cooking.
  9. Center pans on racks and load each shelf evenly to allow for proper air circulation within the cavity.
  10. When baking, weigh or measure the product in each pan to assure even cooking.
  11. When cooking six pans, use rack positions 1, 4, 6,8,10 and 12, starting from the top.
  12. Do not overload the oven. Six pans are suggested for most items, i.e., cakes, cookies, rolls, etc. However, the maximum (13 pans) may be used for fish sticks, chicken nuggets and hamburgers. Cooking times will have to be adjusted.
  13. Muffin pans should be placed in the oven back to front or with the short side of the pans facing the front. This results in the most evenly baked product.
  14. When re-thermalizing frozen casseroles, preheat the oven 100° over the suggested temperature. Return to cooking temperature when the oven is loaded. This will help compensate for the introduction of a large frozen mass into the cavity.
  15. Use pan extenders or two inch deep 18" x 26" pans for batter type products which weigh more than eight pounds, i.e., Pineapple Upside down Cake.
  16. Never place anything directly on the bottom of the oven cavity. This obstructs the airflow and will cause uneven results.
  17. Never operate the oven if any of the exterior covers are removed. These covers are necessary for protection against exposure to live electrical parts and should only be removed when the oven is being serviced by a qualified service personnel.
  18. This is a commercial cooking oven not intended for non commercial cooking installations or non food products.
  19. Use appropriate food pans and trays for ovens.
  20. Use oven mitts when adding or removing trays/pans from oven when oven is operational.
  21. Use care when removing product from the oven to prevent spills which could cause serious injury to bare skin and eyes. Higher rack levels on ovens are at eye level.
  22. Exterior oven exteriors will become hot during operation caution should be observed.
  23. Proper weight handling and distribution of product in tray or pan will prevent sudden shifts in product to avoid spills and injury.
  24. Do not operate ovens blower fan guard has been removed.
  25. Oven operation sound pressure level should not exceed 70 dB(A).
- Note: Moisture will escape around the doors when baking products with heavy moisture content, such as chicken, potatoes, etc. This is normal.

## PROBLEM/SOLUTIONS

<b>Problem</b>	<b>Solution</b>
Cakes are dark on the sides and not done in the center	Lower oven temperature
Cakes edges are too brown	Reduce number of pans or lower oven temperature
Cakes have light outer color	Raise temperature
Cake settles slightly in the center	Bake longer or raise oven temperature slightly. Do not open doors too often or for long periods
Cake ripples	Overloading pans or batter is too thin
Cakes are too coarse	Lower oven Temperature
Pies have uneven color pans	Reduce number of pies per rack or eliminate use of bake pans
Cupcakes crack on top	Lower oven temperature
Meats are browned and not done in center	Lower temperature and roast longer.
Meats are well done and browned	Reduce time. Limit amount of moisture
Meats develop hard crust	Reduce temperature or place pan of water in oven.
Rolls have uneven color	Reduce number or size of pans.

# COOKING GUIDE

The following suggested times and temperatures are provided as a starting guide. Elevation, atmospheric conditions, recipe, cooking pans and oven loading may affect your actual results.

PRODUCT	TEMPERATURE (°F)	TIME
<b>Cakes</b>		
White Sheet Cakes – 5 lbs	300°	20 min
White Sheet Cakes – 6 lbs	300°	22 min
Yellow Sheet Cake – 5 lbs	325°	15 min
Chocolate Layer Cake – 21 oz	300°	22 min
Angel Food Cake	375°	22 min
Brownies	350°	15 min
<b>Breads</b>		
Soda Biscuits	400°	6 min
Yeast Rolls	325°	24 min
Sweet Bread	325°	24 min
Corn Bread	350°	22 min
Gingerbread	300°	24 min
Apple Turnovers	350°	25 min
Cream Puffs	300°	25 min
Sugar Cookies	325°	12 min
Chocolate Chip cookies	375°	8 min
Apple Pie (Fresh)	375°	25 min
Blueberry Pie (Fresh)	350°	30 min
Blueberry Pie (Frozen)	300°	50 min
Pumpkin Pie (Frozen)	300°	50 min
Frozen Pizza	300°	6 min
Macaroni & Cheese	350°	15 min
Fish Sticks	350°	16 min
Stuffed Peppers	350°	45 min
Baked Potatoes	350°	60 min
<b>Meats</b>		
Chick Parts	350°	45 min
Hamburger Patties-10/lb frozen	350°	8 min
Hamburger Patties - 10/lb fresh	350°	5 min
Hamburger Patties - 4/lb frozen	350°	12 min
Hamburger Patties – 4/lb fresh	350°	8 min
Meatloaf – 4lb	325°	45 min
Bacon	350°	10 min
Roast Beef 20lb	325°	3 hr 15 min
Prime Rib 10lb	300°	1 hr 45 min
Stuffed Port chops	350°	45 min
Lamb chops	375°	40 min
Boneless Veal Roast	300°	3 Hr

# COOK AND HOLD

Please refer to the operating instructions the Cook and Hold feature. The times and temperatures listed below are to be used as a starting guide. Your actual results may vary greatly depending on your elevation, atmospheric conditions and other items being cooked at the same time.

Weight in lbs	Time in Hours					
	Temperature: 200°F		Temperature: 250°F		Temperature: 300°F	
	Rare	Medium	Rare	Medium	Rare	Medium
8	2.5	3.5	1.5	2	1.25	1.5
9	2.75	3.75	1.75	2.25	1.25	1.75
10	3	4.25	2	2.5	1.5	1.75
11	3.25	4.5	2	2.75	1.5	1.75
12	3.5	5	2.25	3	1.5	2
13	3.75	5	2.5	3.25	1.5	2.25
14	4	5.75	2.5	3.5	1.75	2.5
15	4.25	6	2.75	3.5	2	2.5
16	4.5	6.25	2.75	3.75	2	2.75
17	4.75	6.5	3	4	2.25	2.75
18	4.75	6.75	3.25	4.25	2.25	3
19	5	7.25	3.25	4.25	2.25	3
20	5.25	7.5	3.5	4.5	2.5	3.25
21	5.5	7.75	3.5	4.75	2.75	3.5
22	5.75	7.75	3.5	4.75	2.75	3.5
23	6	8.25	3.75	5	2.75	3.75
24	6	8.75	3.75	5	2.75	3.75
25	6.25	9	4.25	5.5	3	4
26	6.5	9.25	4.25	5.5	3.25	4.25
27	6.75	9.5	4.25	5.75	3.25	4.25
28	7	9.75	4.5	6	3.25	4.25
29	7.25	10	4.75	6.25	3.5	4.5
30	7.25	10.25	4.75	6.25	3.5	4.5

# CLEANING AND MAINTENANCE

**NOTE:** Disconnect line cord from power supply before cleaning or servicing.

## Break-In Period

When oven is new, operate it for one hour at 375°F (191°C) before you begin your normal cooking operation. After cooling, wipe the interior, including the racks, with a clean damp cloth.

## Exterior Cleaning

Establish a regular schedule. Any spills should be wiped off immediately.

1. The oven should always be allowed to cool sufficiently before any cleaning is attempted.
2. Wipe exposed, cleanable surface when cool with a mild detergent and hot water. Stubborn residue spots may be removed with a lightweight non-metallic scouring pad. Dry thoroughly with a clean cloth.
3. Stubborn stains may be removed by using a non-metallic abrasive pad, rubbing in the direction of the metal's grain. If necessary, for particularly heavy deposits, you may mix a thin paste of water and scouring powder, and apply it with a sponge. Be careful to apply light pressure and remember to rub only in the direction of the grain in the metal.
4. The control panel surface is easily cleaned with hot water, soap and a soft cloth. Do not use hard abrasives, solvent type materials or metallic scouring pads since these will scratch or cloud the surface.
5. Never spray the perforated areas of the control panel with steam or water jets, as this allow moisture into the control cavity. Moisture could damage the electrical components or place the operator at risk of electrical shock.

## Interior Cleaning

Establish a regular cleaning schedule or wipe off on the same day when spillovers occur.

1. Cool down oven.
2. Remove oven racks.
3. Lift rack guides on either side of oven off of holders. Racks and guides may be run through dishwasher while oven cavity is being cleaned.

4. Clean with soap and water using a non-metallic scouring pad, if necessary. If dirt and grease have accumulated, a mild ammonia solution or commercial oven cleaner such as Easy-Off or Dow may be used.
5. To reinstall, reverse procedure. Place the bottom of the rack guide against the cavity wall. Keeping the top pulled away from the wall lift up. Push the top of the guide against the wall and push down locking it into place.

## Fan Area Maintenance

If aluminum foil is routinely used to wrap food or cooking vessels during oven operation, the following preventive maintenance must be performed:

1. Turn power switch to "Off" position
2. Remove oven racks and rack guides.
3. Remove air baffle and clean any stains or deposits.
4. Check blower wheel and air baffle for particles of aluminum foil or food deposits. Clean fins of blower wheel. (CAUTION: edges of blower wheel fins may be sharp).
5. Reinstall the air baffle, rack guides and oven racks.

This simple practice, if performed on a regular basis will keep your Garland oven operating at peak performance.

## Motor Care

The motor on your convection oven is maintenance free since it is constructed with self-lubricating sealed ball bearings. It is designed to provide durable service when treated with ordinary care. We have a few suggestions to follow on the care of your motor. When the motor is operating, it cools itself internally by air entering at the rear of the motor case, provided proper clearance has been allowed.

Since the blower wheel is in the oven cavity it is at the same temperature as the oven. If the motor is stopped while the oven is hot, the heat from the blower wheel is conducted down the shaft and into the armature of the motor. This action could shorten the life of the motor.

We recommend, at the end of the bake or roasting period, when the oven will be idle for any period of time, or before shutting down completely, that the doors be left open slightly to initiate **cool down**. On digital "M" models, the fan will continue to run until the oven cools down to 150°F (66°C).

THIS PAGE INTENTIONALLY LEFT BLANK



Welbilt offers fully-integrated kitchen systems and our products are backed by KitchenCare<sup>®</sup> aftermarket parts and service. Welbilt's portfolio of award-winning brands includes Cleveland<sup>™</sup>, Convothem<sup>®</sup>, Crem<sup>®</sup>, Delfield<sup>®</sup>, fitkitchen<sup>®</sup>, Frymaster<sup>®</sup>, Garland<sup>®</sup>, Kolpak<sup>®</sup>, Lincoln<sup>®</sup>, Manitowoc<sup>®</sup>, Merco<sup>®</sup>, Merrychef<sup>®</sup> and Multiplex<sup>®</sup>.

*Bringing innovation to the table • [welbilt.com](http://welbilt.com)*