



# INSTALLATION / OPERATION & SERVICE MANUAL

**GARLAND 3 PLATEN  
GAS & ELECTRIC  
CLAMSHELL GRILLS  
WITH PRODUCT RECOGNITION**

**MODELS:**

**MWE3W-1**

**MWE3S-1**

**MWG3W-1**



**FOR YOUR SAFETY:**  
DO NOT STORE OR USE GASOLINE OR OTHER  
FLAMMABLE VAPORS OR LIQUIDS IN THE  
VICINITY OF THIS OR ANY OTHER  
APPLIANCE

**WARNING:**  
IMPROPER INSTALLATION, ADJUSTMENT,  
ALTERATION, SERVICE OR MAINTENANCE  
CAN CAUSE PROPERTY DAMAGE, INJURY, OR  
DEATH. READ THE INSTALLATION,  
OPERATING AND MAINTENANCE  
INSTRUCTIONS THOROUGHLY  
BEFORE INSTALLING OR  
SERVICING THIS EQUIPMENT

PLEASE READ ALL SECTIONS OF THIS MANUAL AND  
RETAIN FOR FUTURE REFERENCE.

THIS PRODUCT HAS BEEN CERTIFIED AS  
COMMERCIAL COOKING EQUIPMENT AND MUST  
BE INSTALLED BY PROFESSIONAL PERSONNEL AS  
SPECIFIED.

INSTALLATION AND ELECTRICAL CONNECTION MUST  
COMPLY WITH CURRENT CODES:

IN CANADA - THE CANADIAN ELECTRICAL CODE  
PART 1 AND / OR LOCAL CODES.

IN USA – THE NATIONAL ELECTRICAL CODE ANSI /  
NFPA – CURRENT EDITION.

ENSURE ELECTRICAL SUPPLY CONFORMS WITH  
ELECTRICAL CHARACTERISTICS SHOWN ON THE  
RATING PLATE.

For Your Safety:

Post in a prominent location, instructions to be  
followed in the event the user smells gas. This  
information shall be obtained by consulting your  
local gas supplier

MANUFACTURED EXCLUSIVELY FOR McDonald's BY  
GARLAND COMMERCIAL RANGES  
<http://www.garland-group.com>





# CONTENTS

<b>INTRODUCTION</b> _____	<b>5</b>	<b>OPERATION PROCEDURES</b> _____	<b>36</b>
<b>WARRANTY</b> _____	<b>5</b>	General Overview: .....	36
<b>SHIPPING DAMAGE PROCEDURE</b> _____	<b>5</b>	To turn the grill on: .....	37
<b>MECHANICAL SPECIFICATIONS</b> _____	<b>8</b>	To Select a Menu item: .....	37
Dimension Models: MWE3W-1, MWG3W-1 .....	8	Menu Item Library .....	37
Dimension Models: MWE3S-1 .....	9	Indicator Lights .....	37
<b>ELECTRICAL INPUT SPECIFICATIONS - DELTA</b> _____	<b>10</b>	To enter the standby mode: .....	37
<b>ELECTRICAL INPUT SPECIFICATIONS - WYE</b> _____	<b>12</b>	To Exit the standby Mode: .....	37
Input Specifications, GAS Grills, North America: .....	13	To display the current temperatures:.....	38
Input Specifications, GAS Grills, CE Approved Model MWG3W-CE: .....	13	Breakfast In Manual mode.....	38
<b>INSTALLATION &amp; START UP</b> _____	<b>14</b>	Lunch In Manual mode.....	38
Installation Store Responsibilities: .....	14	To Change The Cook Time for a Menu Item.....	38
A start-up DOES NOT include: .....	14	Breakfast In Auto mode .....	38
A start-up DOES include: .....	14	Lunch In Auto mode .....	38
Items included with the purchase of your new grill from Manufacturer: .....	14	Transition Cooking.....	39
Items NOT included from the manufacturer and should be purchased from the Kitchen Equipment Supplier (KES): .....	14	To Shutdown Grill.....	39
Installation of Casters .....	15	<b>PRODUCT RECOGNITION</b> _____	<b>39</b>
Power Supply Connection.....	16	<b>COMMON PRODUCT RECOGNITION ISSUES</b> _____	<b>40</b>
Mennekes 3 & 5 Pins (Option 1).....	17	<b>PATTY PLACEMENT</b> _____	<b>41</b>
Mennekes 7 Pins (Option 2) .....	17	<b>BEEF INTEGRITY</b> _____	<b>42</b>
Terminal Blocks Diagram .....	17	<b>PROGRAM LOGIC TREE; PRODUCT MENU</b> _____	<b>43</b>
Exhaust hood Type & Platen Height.....	18	<b>CONTROL PROGRAMMING; PRODUCT MENU</b> _____	<b>44</b>
LonWorks Information & Commissioning .....	19	To change the name of an existing menu item .....	44
Setting the Proper Combustion Levels.....	19	To activate / deactivate a menu item in the Normal Operating mode library, or change its day-part .....	44
Start-up Procedure .....	20	To change the grill surface set point temperature .....	44
Grill StartUp Sample .....	21	To change the grill upper platen set point temperature .....	44
<b>TEMPERATURE PROBE CALIBRATION</b> _____	<b>22</b>	To Change the INSTANT ON TIME .....	45
<b>THERMOCOUPLE LOCATION</b> _____	<b>25</b>	To Change the REMOVE IN TIME .....	45
<b>INSTALLATION OF WRAP AROUND RELEASE MATERIAL MOUNTING BRACKETS</b> _____	<b>26</b>	To Change the MULTI STAGE TIME .....	45
<b>INSTALLATION OF SPLASH SHIELD</b> _____	<b>26</b>	To Change the REMOVE ALARM .....	45
<b>INSTALLATION OF RELEASE MATERIAL</b> _____	<b>27</b>	To Change the GAP SETTING .....	45
<b>INSTALLATION OF VAPOR SHIELD</b> _____	<b>28</b>	To Change the GAP MUL/PR START .....	46
<b>GRILL ACCESSORIES</b> _____	<b>28</b>	To Change the GAP MULTI STAGE (1,2 or3) .....	46
Splash Shield .....	28	To Change the MUST REMOVE IN .....	46
Teflon Wraparound Kits .....	28	To Change the TOAST BUNS TIME.....	46
Vapor Shield .....	28	To Change the TOAST BUNS ALARM (Auto / Manual) .....	46
3Phase 4-Wire (50 & 30 Amps) Cord.....	29	To Change the TOO COOL FLAG .....	47
Teflon Sheet, Rod & Clip.....	30	To Change the FLIP TIME .....	47
<b>CLEANING &amp; MAINTENANCE</b> _____	<b>31</b>	To Change the FLIP ALARM.....	47
<b>PULL / PUSH GRILL PROCEDURE</b> _____	<b>34</b>	To Change the SEAR TIME .....	47
<b>DESCRIPTION OF GRILL CONTROL</b> _____	<b>35</b>	To Change the SEAR ALARM.....	48
<b>ERROR MESSAGING</b> _____	<b>36</b>	To Add NEW Menu Items .....	48
		To activate Clean Mode .....	48

# CONTENTS

<b>PROGRAM LOGIC TREE; SYSTEM MENU</b> _____	<b>49</b>	<b>TO UPDATE MAIN CONTROL SOFTWARE</b> _____	<b>73</b>
<b>PROGRAM LOGIC; CONFIGURATION &amp; CALIBRATION SUBMENU</b> _____	<b>50</b>	<b>TO UPDATE MOTOR CONTROL SOFTWARE</b> _____	<b>75</b>
CONFIGURATION SUBMENU .....	50	<b>ELECTRIC HEATING ELEMENTS</b> _____	<b>76</b>
CALIBRATION SUBMENU .....	50	<b>TROUBLESHOOTING GUIDE INFORMATION</b> _____	<b>78</b>
<b>PROGRAM LOGIC; CALIBRATION SUBMENU</b> _____	<b>51</b>	<b>TROUBLESHOOTING GUIDE INFORMATION</b> _____	<b>79</b>
CALIBRATION SUBMENU .....	51	<b>TROUBLESHOOTING GUIDE INFORMATION</b> _____	<b>80</b>
<b>PROGRAM LOGIC; CALIBRATION SUBMENU</b> _____	<b>52</b>	<b>ERROR CODES TROUBLESHOOTING GUIDE INFORMATION</b> _____	<b>84</b>
CALIBRATION SUBMENU .....	52	<b>GRILL EXTERIOR, ALL MODELS</b> _____	<b>104</b>
SERVICE SUBMENU .....	52	<b>GRILL EXTERIOR, ALL MODELS</b> _____	<b>105</b>
<b>CONTROL PROGRAMMING; SYSTEM MENU</b> _____	<b>53</b>	<b>GRILL ELEMENT, ELECTRIC MODELS</b> _____	<b>106</b>
<b>FACTORY DEFAULT SETTING</b> _____	<b>55</b>	<b>GRILL ELEMENT, ELECTRIC MODELS</b> _____	<b>107</b>
Factory Default Setting - Product Menu - World .....	55	<b>GAS BURNER, GAS MODELS</b> _____	<b>108</b>
Factory Default Setting - Product Menu - Canada, Australia & UK .....	56	<b>GAS BURNER, GAS MODELS</b> _____	<b>109</b>
Factory Default Setting - Product Menu - Japan & Hong Kong	57	<b>UPPER PLATEN ASSEMBLY, ALL MODELS</b> _____	<b>110</b>
<b>PLATEN LEVELING</b> _____	<b>58</b>	<b>UPPER PLATEN ASSEMBLY, ALL MODELS</b> _____	<b>111</b>
<b>TO SET REED SWITCHES</b> _____	<b>62</b>	<b>PLATEN LIFTING MECHANISM, ALL MODELS</b> _____	<b>112</b>
<b>TO REPLACE MAGNET ASSEMBLY</b> _____	<b>63</b>	<b>PLATEN LIFTING MECHANISM, ALL MODELS</b> _____	<b>113</b>
<b>TO REPLACE THE REED SWITCH</b> _____	<b>64</b>	<b>WIRING HARNESSSES, ALL MODELS</b> _____	<b>114</b>
<b>REED SWITCH OPERATION</b> _____	<b>65</b>	<b>WIRING DIAGRAM, MWE3W/S 200-240V - DELTA 50/60</b> _	<b>119</b>
<b>TO REPLACE THE LINEAR ACTUATOR</b> _____	<b>68</b>	<b>DECLARATION OF CONFORMITY (CE Marked Models)</b> 124	
<b>TO REPLACE TOP PLATEN ASSEMBLY</b> _____	<b>70</b>	<b>INDEX</b> _____	<b>125</b>
<b>TO REPLACE THE SHAFT SEALS</b> _____	<b>71</b>		
<b>TO REPLACE THE SHAFT SEALS &amp; CAP O-RINGS</b> _____	<b>71</b>		

## INTRODUCTION

The Garland clamshell grill, manufactured exclusively for McDonald's, provides a method for efficient two-sided cooking, while accommodating a variety of products. The unit will also serve as a flat grill, and meets all of McDonald's standards for safety, efficiency, and cleanliness.

## WARRANTY

This warranty covers defects in material and workmanship under normal use providing that:

- a. the equipment has not been accidentally or intentionally damaged, altered or misused.
- b. the equipment is properly installed, adjusted, operated and maintained in accordance with national and local codes and in accordance with the installation instructions provided with this product.
- c. the warranty serial number affixed to the appliance by us has not been defaced, obliterated or removed.
- d. an acceptable report for any claim under this warranty is supplied to us.

The equipment warranty coverage remains in force for two (2) years, (parts and labor), from the date the equipment is put into operation.

The Garland Group agrees to repair or replace, at it's option, any part that proves to be defective in material or workmanship at no charge for the part or normal labor.

We assume no responsibility for installation, adjustments, diagnosis, or normal maintenance such as: lubrication of springs or valves. We exclude failures caused by erratic voltage or gas supplies.

We assume no responsibility for travel costs beyond 100 miles round trip, travel other than overland, and overtime costs of repair.

We exclude broken glass, paint and porcelain finish, surface rust, gasket material, ceramic material, light bulbs and fuses from normal coverage.

We exclude damage or dysfunction caused by fire, flood, and like "Acts of God" that are beyond the control of The Garland Group.

The Garland Group's liability on a claim of warranty shall not exceed the price of the material and/or service, which caused the claim.

This warranty is limited and is in lieu of all other warranties, expressed or implied. The Garland Group, our employees, or our agents shall not be held liable for any claims of personal injury or consequential damage or loss.

This warranty gives you specific legal rights, and you may have other rights which vary from state to state.

## SHIPPING DAMAGE PROCEDURE

Please note that the Garland equipment was carefully inspected and packed by skilled personnel before leaving the factory. The transportation company assumes full responsibility for safe delivery upon acceptance of the equipment. What to do if the equipment arrives damaged:

1. File a claim immediately regardless of the extent of damage.
2. Be sure to note, "visible loss or damage," on the freight bill or express receipt and have the person making the delivery sign it.
3. Concealed loss or damage: if damage is unnoticed until the equipment is unpacked, notify the freight company immediately, (within 15 days), and file a concealed damage claim.

## SAFETY

This appliance is for professional use and shall be used only by qualified personnel.

**WARNING:** Accessible parts may become hot during use. Young children should be kept away. This appliance is not intended for use by persons (including children) with reduced physical, sensory or mental capabilities, or lack of experience and knowledge, unless they have been given supervision or instruction concerning use of the appliance by a person responsible for their safety."

**CAUTION: THIS EQUIPMENT MUST ONLY BE OPERATED UNDER AN APPROVED HOOD SYSTEM IN ACCORDANCE WITH LOCAL REGULATIONS IN FORCE.**

**DO NOT** OPERATE THE GRILL UNLESS IT HAS BEEN COMMISSIONED (START-UP) BY A FACTORY AUTHORIZED SERVICE CENTER.

**DO NOT** operate the grill without reading this operation manual.

**DO NOT** operate the clamshell grill unless it has been properly installed and grounded.

**DO NOT** operate the clamshell grill unless all service and access panels are in place and fastened properly.

Means of disconnection, must be incorporated in the fixed wiring in accordance with local wiring rules (such as a switch, fuse, or circuit breaker). External equipotential bonding conductor provided on rear of appliance. Use as applicable, in accordance with local wiring rules.

The Garland clamshell grill is a semi-automatic cooking appliance. The upper platen is lowered automatically, following the manual, single-handed or two handed based on the model, initiation of the cooking cycle, and raised automatically upon completion of the cooking cycle.

**WARNING:**

When two sided cooking, the area between the upper platen and the griddle plate and the area between upper platen and ventilation hood should be regarded as a "**DANGER ZONE**". During two sided cooking the operator must keep body parts and tools clear of the danger zone when platens are in motion. When used as a flat grill, unexpected movement of platens can occur during cleaning or servicing. For whatever reason, be it cleaning, maintenance or normal operation, any exposed person must use extreme caution if within this danger zone. Temperatures on solid cooking surfaces are intended to operate above 120C (250F).

In two sided cooking the upper platen remains in the lowered position by nature of it's own weight. It is not locked down. It can be raised by lifting of the handle on the front of the platen, which pivots the platen about its rear mounting point.

The clamshell grill must only be used for single and two sided cooking of foodstuffs in a McDonald's store.

**SOUND EMISSIONS:** Sound pressure levels at the grill operator's position may exceed 70 dB(A) when audible alarms are active. Audible volume may be adjusted to below 70 dB(A). See Control Programming Section.

**WARNING:** To avoid serious personal injury: **DO NOT** attempt to repair or replace any part of the clamshell grill unless all main power supplies to the grill have been disconnected.

**USE EXTREME CAUTION** in setting up, operating and cleaning the clamshell grill to avoid coming in contact with hot grill surfaces or hot grease. Suitable protective clothing should be worn to prevent the risk of burns.

**WARNING:** This appliance must not be cleaned with a water jet. **DO NOT** apply ice to a HOT grill surface.

**NOTE:** All warning labels and markings on the grill, which call attention to further dangers and necessary precautions.

**HAZARD COMMUNICATION STANDARD, (HCS) -** The procedures in this manual include the use of chemical products. These chemical products will be printed in bold face, followed by the abbreviation (**HCS**) in the text portion of the procedure. See the Hazard Communication Standard, (HCS) manual for the appropriate Material Safety Data Sheet(s), (MSDS).

**WARNING:** After turning the master power switch to the START position, the grill will go through an initialization process. If the upper platens are in the lowered position they will return to their raised upper position.

## SAFETY

---

---

**MAINTENANCE** - the platen support arms carriage block bearing bushings, the platen adjuster nuts, the platen support (shoulder) bolt and the cam follower should be checked annually for wear. Should there be any noticeable play in the bearing bushings and any visible wear on the platen adjuster nuts, platen support bolts or cam follower, then they must be replaced.

**MAINTENANCE** - the audible alarm that sounds at the end of a cook cycle is to advise the operator that the platen is about to move. The function of this device may be tested by pushing the left hand CANCEL button. If no sound is heard, ensure that the alarm volume is not set too low in SYSTEM SETUP. If there is still no sound then a service engineer should be called out to rectify the fault.

**SERVICE AND CLEANING** - The grill may be secured in the grill bay by the installer using two anchors that lock onto the front casters. If the grill is to be moved out of the bay for cleaning or service, remove the anchor from each caster by turning the knob counterclockwise to loosen the retainer. When the retainer is free of the caster, lay the assembly aside on the floor.

**CLEANING** - **NEVER** clean the grill, interior or exterior, using a high-pressure sprayer, water jet, vapor steam cleaner or any other liquid sprayer. **NEVER** use ice to cool the grill for cleaning. **USE ONLY** approved cleaners by McDonald's.

**NOTE:** If anchors are present, the anchor assembly remains fastened to the back wall of the grill bay. After service or cleaning is complete, return the grill to its position in the bay and reattach the anchors by placing the retainer on the caster post and turning the knob clockwise to tighten. For safety reasons, the grill must be secured in the grill bay in this manner before operation can resume.

**WARNING:**

**Pinch Hazard** keep hands and tools clear when platens are in motion. Unexpected movement of platens can occur during cleaning or servicing process. ***Turn Grill Off*** at main switch when cleaning platen.

# MECHANICAL SPECIFICATIONS

**Dimensions:**

**Models MWE3W-1, MWG3W-1**

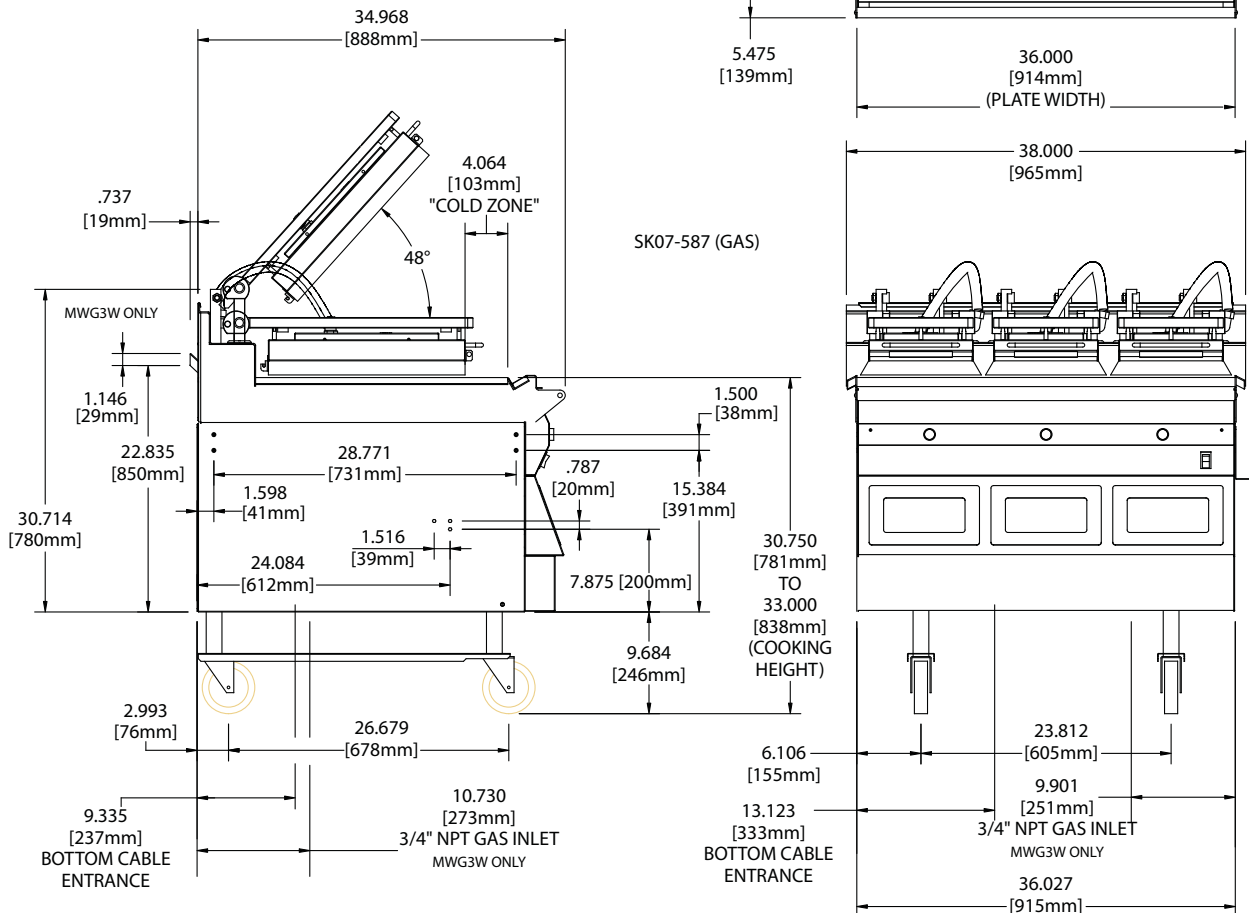

# MECHANICAL SPECIFICATIONS

**Dimensions:**  
**Models MWE3S-1**

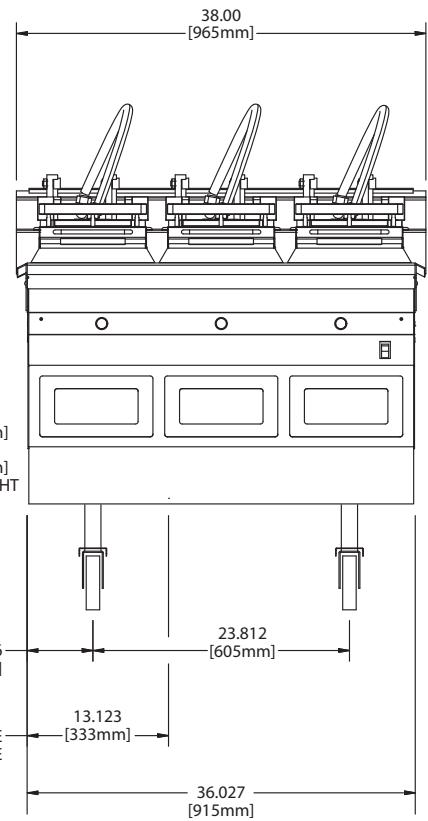
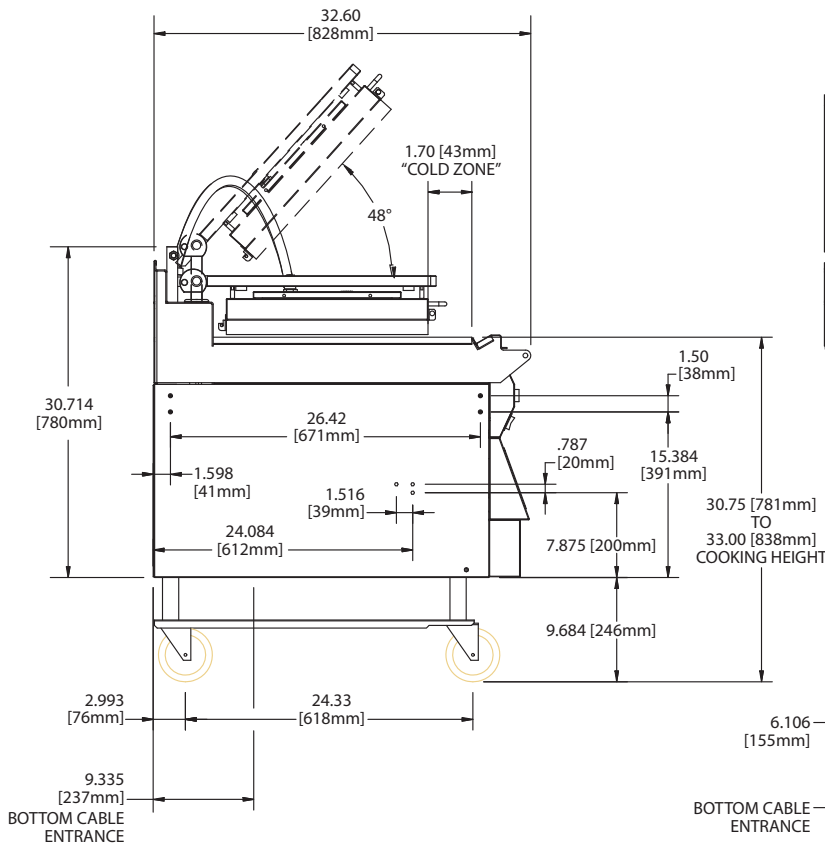
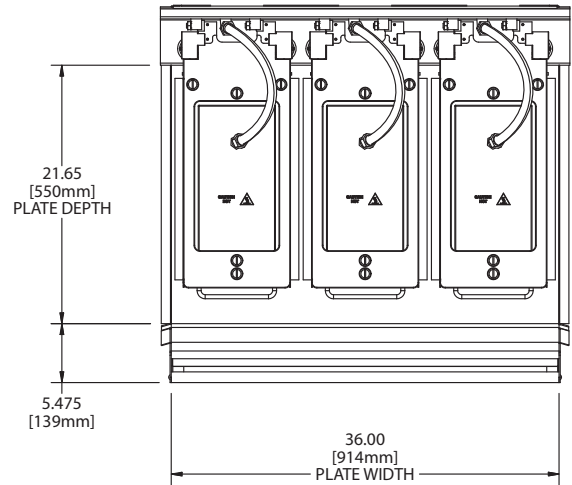

## ELECTRICAL INPUT SPECIFICATIONS - DELTA

DELTA - 200 Volts Models													
Model		Drawing		Con- trol	MCB	Total loads Kw				Amps/line			
				I/E	L1-L3	L1-L2	L2-L3	L3-L1	All	Ctrl	L1	L2	L3
<b>3 Platen</b>	Electric	4530440	TB1		600	2.3	2.7	2.9	7.9		21.7	22.6	24.3
			TB2	78				0.1	0.7				
			TB3			4.2	5.4	4.6	14.6		43.4	39.9	43.4
	Gas	4530442	TB1		600	3.0	3.0	3.6	9.6		26.0	28.7	28.7
			TB2	380				0.4	3.3				

DELTA - 208 Volts Models													
Model		Drawing		Con- trol	MCB	Total loads Kw				Amps/line			
				I/E	L1-L3	L1-L2	L2-L3	L3-L1	All	Ctrl	L1	L2	L3
<b>3 Platen</b>	Electric	4530440	TB1		600	2.4	2.8	3.0	8.2		21.5	22.4	24.0
			TB2	78				0.1	0.6				
			TB3			4.8	5.6	4.8	15.1		43.1	39.7	43.1
	Gas	4530442	TB1		600	3.3	3.3	3.9	10.4		27.1	29.6	29.6
			TB2	380				0.4	3.2				

DELTA - 220 Volts Models													
Model		Drawing		Con- trol	MCB	Total loads Kw				Amps/line			
				I/E	L1-L3	L1-L2	L2-L3	L3-L1	All	Ctrl	L1	L2	L3
<b>3 Platen</b>	Electric	4530440	TB1		600	2.4	2.8	3.0	8.2		20.4	21.2	22.7
			TB2	78				0.1	0.6				
			TB3			4.8	5.6	4.8	15.1		40.7	37.5	40.7
	Gas	4530442	TB1		600	3.3	3.3	3.9	10.4		25.6	28.0	28.0
			TB2	380				0.4	3.0				

## **ELECTRICAL INPUT SPECIFICATIONS - DELTA**

<b>DELTA - 230 Volts Models</b>													
Model		Drawing		<b>Control</b>	<b>MCB</b>	<b>Total loads Kw</b>				<b>Amps/line</b>			
				I/E	L1-L3	L1-L2	L2-L3	L3-L1	All	Ctrl	L1	L2	L3
<b>3 Platen</b>	Electric	4530440	TB1		600	2.4	2.8	3.0	8.2		19.5	20.2	21.7
			TB2	78					0.1	0.6			
			TB3			4.8	5.6	4.8	15.1		38.9	35.9	38.9
	Gas	4530442	TB1		600	3.3	3.3	3.9	10.4		24.5	26.8	26.8
			TB2	380					0.4	2.9			

<b>DELTA - 240 Volts Models</b>													
Model		Drawing		<b>Control</b>	<b>MCB</b>	<b>Total loads Kw</b>				<b>Amps/line</b>			
				I/E	L1-L3	L1-L2	L2-L3	L3-L1	All	Ctrl	L1	L2	L3
<b>3 Platen</b>	Electric	4530440	TB1		600	2.4	2.8	3.0	8.2		18.7	19.4	20.8
			TB2	78					0.1	0.6			
			TB3			4.8	5.6	4.8	15.1		37.3	34.4	37.3
	Gas	4530442	TB1		600	3.3	3.3	3.9	10.4		23.5	25.7	25.7
			TB2	380					0.4	2.7			

## **ELECTRICAL INPUT SPECIFICATIONS - WYE**

WYE - 380 Volts Models													
Model		Drawing		Con- trol	MCB	Total loads Kw				Amps/line			
				I/E		L1-L3	L1-L2	L2-L3	L3-L1	All	Ctrl	L1	L2
<b>3 Platen</b>	Electric STD	4530442	TB1		600	7.8	8.4	7.2	23.3		35.3	38.1	32.6
			TB2	78					0.1	0.4			
	Electric H.K.	4530440	TB1		600	3.0	2.8	2.4	8.2		13.6	12.7	10.9
			TB2	78					0.1	0.4			
			TB3			4.8	5.6	4.8	15.1		21.7	25.4	21.7
	Gas	4530442	TB1		600	3.9	3.3	3.3	10.4		17.5	14.8	14.8
TB2			380.4					0.4	1.7				

WYE - 400 Volts Models													
Model		Drawing		Con- trol	MCB	Total loads Kw				Amps/line			
				I/E		L1-L3	L1-L2	L2-L3	L3-L1	All	Ctrl	L1	L2
<b>3 Platen</b>	Electric STD	4530442	TB1		600	7.8	8.4	7.2	23.3		33.6	36.2	31.0
			TB2	78					0.1	0.3			
	Electric H.K.	4530440	TB1		600	3.0	2.8	2.4	8.2		12.9	12.1	10.3
			TB2	78					0.1	0.3			
			TB3			4.8	5.6	4.8	15.1		20.6	24.1	20.6
	Gas	4530442	TB1		600	3.9	3.3	3.3	10.4		16.7	14.1	14.1
TB2			380.4					0.4	1.6				

WYE - 415 Volts Models													
Model		Drawing		Con- trol	MCB	Total loads Kw				Amps/line			
				I/E		L1-L3	L1-L2	L2-L3	L3-L1	All	Ctrl	L1	L2
<b>3 Platen</b>	Electric STD	4530442	TB1		600	7.8	8.4	7.2	23.3		32.3	34.8	29.8
			TB2	78					0.1	0.3			
	Electric H.K.	4530440	TB1		600	3.0	2.8	2.4	8.2		12.5	11.6	9.9
			TB2	78					0.1	0.3			
			TB3			4.8	5.6	4.8	15.1		19.9	23.2	19.9
	Gas	4530442	TB1		600	3.9	3.3	3.3	10.4		16.1	13.6	13.6
TB2			380.4					0.4	1.6				

# GAS INPUT SPECIFICATIONS

## Input Specifications, GAS Grills, North America:

GAS INPUT						
GAS	MAX INPUT (NET) PER BURNER (BTU/H)	TOTAL INPUT RATING (BTU/H)	INJECTOR SIZE	AIR SHUTTER SETTING (MM)	SUPPLY PRESSURE (IN W.C.)	BURNER MANIFOLD PRESSURE (IN W.C.)
NATURAL GAS	32,000	96,000	#35	10	7.0	3.5
PROPANE	32,000	96,000	#43	10	11.0	3.5

## Input Specifications, GAS Grills, CE Approved Model MWG3W-CE:

GAS INPUT							
GAS GROUP	MAX INPUT (NET) PER BURNER (kW)	TOTAL INPUT RATING (kW)	INJECTOR SIZE	AIR SHUTTER SETTING (mm)	SUPPLY PRESSURE (mbar)	BURNER PRESSURE (mbar)	VOLUMETRIC GAS RATE PER BURNER
G20 NG	8.9	26.7	2.79mm (#35)	10.0	20/25	8.7	0.94 m³/h
G25 NG	7.6	22.8	2.79mm (#35)	10.0	20	8.7	0.93 m³/h
G31 LPG	9.6	28.8	2.26mm (#43)	10.0	37/50	8.7	0.94 m³/h

NET HEATING VALUE BY GAS GROUP		
G20	G25	G31
34.02 MJ/m³; 0.555 SG	29.25 MJ/m³; 0.613 SG	88.0 MJ/m³ (46.34 MJ/kg); 1.55 SG

GAS CATEGORIES		
CATEGORY	DESTINATION COUNTRIES	SUPPLY PRESSURE (mbar)
I <sub>2H</sub>	AT, CH, CZ, DK, ES, FI, GB, IE, IS, IT, NO, PT, SE	20.0
I <sub>2E</sub>	DE, LU	20.0
I <sub>2L</sub>	NL	25.0
I <sub>2ER</sub>	FR	20.0 / 25.0
I <sub>3P</sub>	NL	30.0
I <sub>3P</sub>	BE, CH, CZ, ES, FR, GB, GR, IE, LU	37.0
I <sub>3P</sub>	BE, CH, DE, CZ, ES, FR, NL	50.0

# INSTALLATION & START UP

## Installation Store Responsibilities:

- Ensure grill gets install by a competent, qualified, trained personnel.
- Ensure store readiness of utilities, product & personnel.
- Contact your local Garland Factory Authorized Service Center for a start-up date.
- Participate in the start-up to ensure a successful start-up and familiarity with the grill.
- Conduct training with your crew personnel to ensure maximum utilization of the grill.

Once the installation is complete as per the procedures below, a factory authorized service company MUST start-up the grill according to Garland Commercial Ranges start-up standards.

## A start-up DOES NOT include:

1. Uncrating the unit
2. Placing the unit in its position under the exhaust hood.
3. Leveling the grill on the floor under the exhaust hood.
4. Attaching the supply cord(s) unless supplied by the factory.
5. Making adjustments to the ventilation system.
6. Sheet metal work required due to improper exhaust hood application.
7. Adjusting the grill to achieve beef integrity that deviates from the McDonalds standard.

## A start-up DOES include:

1. Verification of supply voltage and, if applicable gas supply.
2. Leak test and gas pressure check on gas grills.
3. Electrical safety check.
4. Verify operation of grill by allowing unit to attain set temperature.
5. Verify operation of platens, if applicable, and timer functions.
6. Ensure time out alarm is functional and platens raise (if applicable)

7. Set proper gas and verify with beef integrity check that two consecutive runs yield the approved beef integrity results as per McDonalds standards.
8. Conduct brief training of store manager on the operation of the grill.

## Items included with the purchase of your new grill from Manufacturer:

1. One (1) World Grill gas & electric included the following list, except countries mentioned;

Part #	Description	Wrap Around	Non-Wrap Around
4521792	Teflon Sheet (Japan not included)	0	6
4527643	Teflon Release Sheet	9	0
4527294	Teflon Sheet Clip	15	3
4521355	Teflon Bar, Rear	3	3
4523492	Splash Shield	3	3
4525436	Splash Shield (Japan only)	0	3
4530053	W/A Plate, Vapor Shield (UK & Japan not included)	3	3
4530054	Silicone, Front, Vapor (UK & Japan not included)	3	3
Part #	Description	Qty	
4517563	5" Front Swivel Caster w/Brake	2	
1792003	5" Rear Swivel Caster	2	
4523352	Leg Brace Locking Bracket - Standard	1	

2. One (1) World Grill gas model only included the following;

Description	Qty	Description	Qty
13" Nipple	1	Shut Off Valve	1
3/4 Street Elbows	2	Bracket, Pipe Hanger	1
Coupling	1	Screws	4
Pipe & Bracket Assy	1	Label	1
Nipple	1	Connection Instruction	1
Hanger Brackets	2		

## Items NOT included from the manufacturer and should be purchased from the Kitchen Equipment Supplier (KES):

1. Any electrical cords needed for application.
2. Any flue box needed for application.
3. Any grease traps or grease rails needed for application.

# INSTALLATION & START UP *(continued)*

## THE FOLLOWING INSTALLATION PROCEDURE CAN BE PERFORMED BY A:

- FACTORY AUTHORIZED SERVICE CENTER
- AN APPROVED QUALIFIED INSTALLATION PERSONNEL APPROVED BY PURCHASER OF GRILL
- LICENSED INSTALLER CONTRACTED BY KES.
- CONTACT LOCAL GARLAND FACTORY AUTHORIZED SERVICE CENTER FOR MORE DETAILS. Uncrate unit from crating material

**CAUTION:**

PRIOR TO INSTALLATION, CHECK THE ELECTRICAL SUPPLY TO ENSURE INPUT VOLTAGE AND PHASE MATCH THE EQUIPMENT VOLTAGE RATING AND PHASE. MANY LOCAL CODES EXIST, IT IS THE RESPONSIBILITY OF THE OWNER/INSTALLER TO COMPLY WITH THESE CODES.

**NOTE: ENSURE THAT PLATENS ARE STRAPPED DOWN SECURELY THROUGH STEP 6 TO PREVENT PLATENS FROM RAISING. SEVERE DAMAGE MAY OCCUR.**

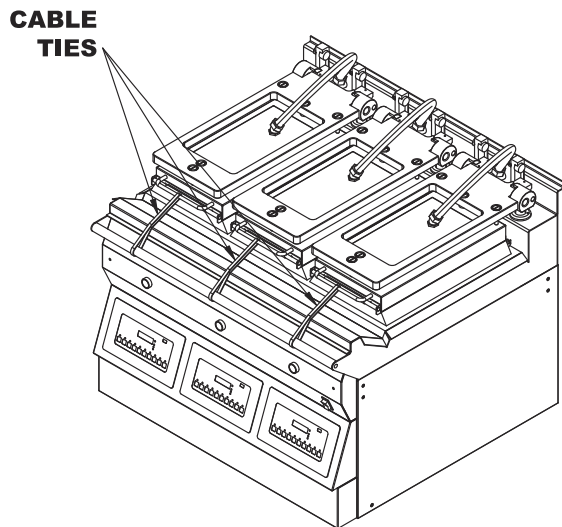

**WARNING, HEAVY OBJECT!**  
The following procedure will require use of lifting aids and proper lifting technique when removing or replacing. To avoid serious injuries use assistance when moving or lifting.

## Installation of Casters

1. Put a pair of heavy gloves to protect your hands and wear a lumbar support for lower back. Safety is the first concern when moving a heavy grill since it weighs approximately 950lbs (431kg) or more.
2. Next procedure will require use of lifting aids and proper lifting/moving techniques. Slide the grill away from walls.
3. Check out the leg brace locking bracket included with your purchased, Ensure you understand the front and the back as shown below.

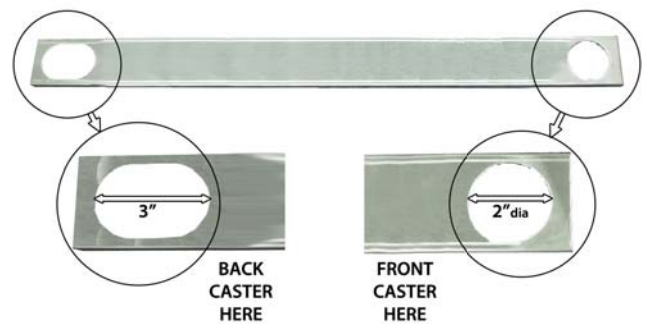

4. Check out the caster included with your purchased, Ensure you understand the front and the rear casters as shown below.



5. Tip unit over on its back. Install casters & channels as shown diagram below. Bracket notch facing the floor.

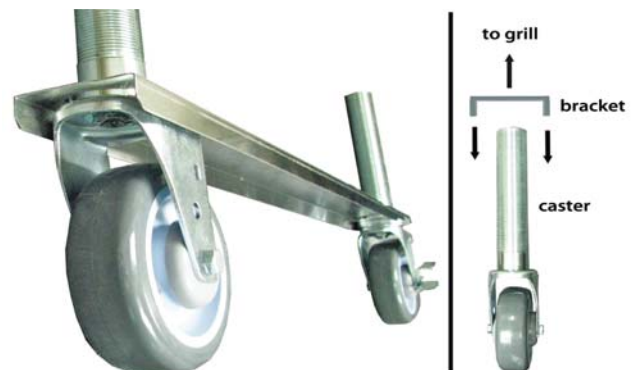

# INSTALLATION & START UP *(continued)*

**WARNING:**

It is recommended that the rear casters are screwed in all the way before tipping the unit.

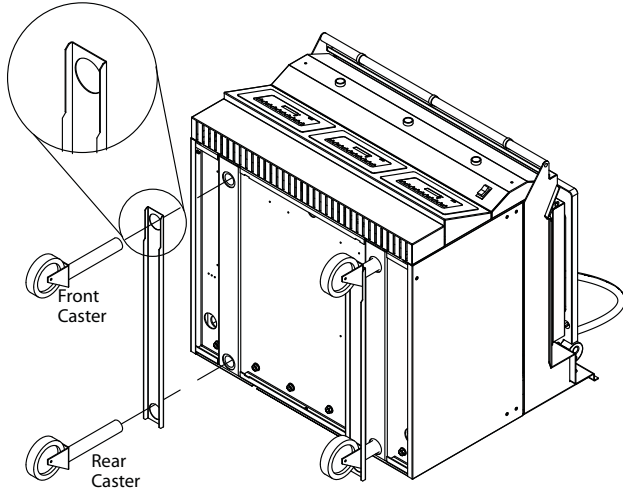

6. Block back caster in place to avoid the unit sliding forward or backward.
7. Carefully rotate grill back on its casters. Now you may cut and remove the platen securing straps.
8. Remove back body side and Install power cords per your country / area's specifications.

**WARNING:**

The appliances must be electrically grounded in accordance with local codes, or in the absence of local codes, with the National Electrical Code ANSI/NFPA 70, or the Canadian Electrical Code CSA C22.1 as applicable.

**Power Supply Connection**

All electric connections must be made by a qualified, properly equipped technician.

**NOTE: WIRING DIAGRAM LOCATED INSIDE LOWER FRONT PANEL.**  
**“DISCONNECT POWER BEFORE OPENING”**

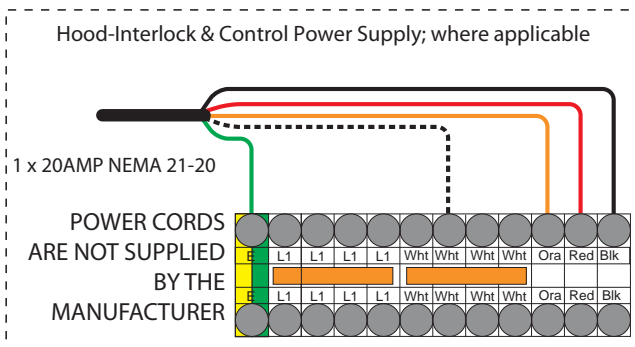
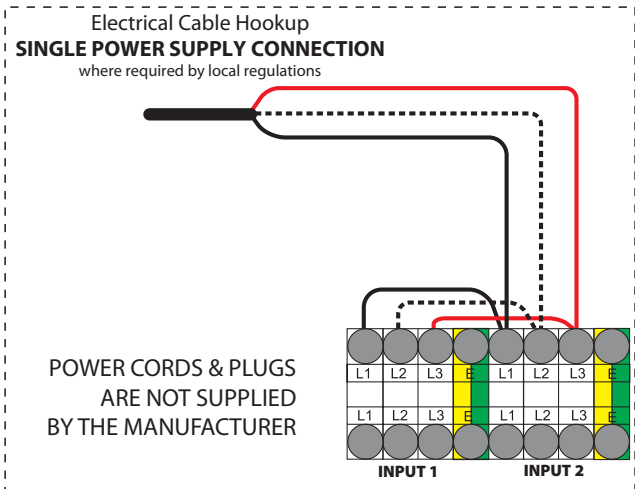
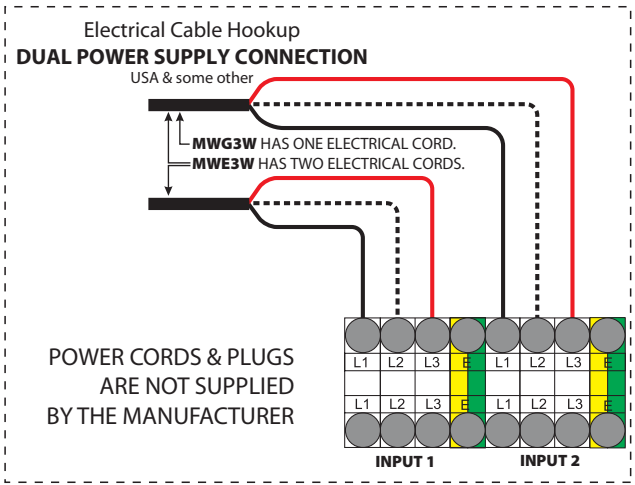

# INSTALLATION & START UP *(continued)*

Important Note:

Mennekes option is available only in some configurations, check with your supplier for more details.

## Mennekes 3 & 5 Pins (Option 1)

Connector	Pins	Intended Load	Connected to
Mennekes 5 Pins	1,2,3,4, GND	Grill and Platen Heaters ~3N 380/400/415 32Amps 50/60Hz	TB1 L1, L2, L3, N, GND
Mennekes 3 Pins	1,2,GND	~1N 120-250 VAC, 16A Control loads (N3, MCB, Ignition controller, blower, gas valve)	TB2 Orange & White Replace jumpers J-N and J-L1

## Mennekes 7 Pins (Option 2)

Connector	Pins	Intended Load	Connected to
Mennekes 7 Pins	1,2,3,4, GND	Grill and Platen Heaters ~3N 380/400/415 32Amps 50/60Hz	TB1 L1, L2, L3, N, GND
	5,6	Switch, Pilot duty only 10A 250VAC, 15A 125VAC, 12(6)A 250VAC T85	TB2 Black & Red

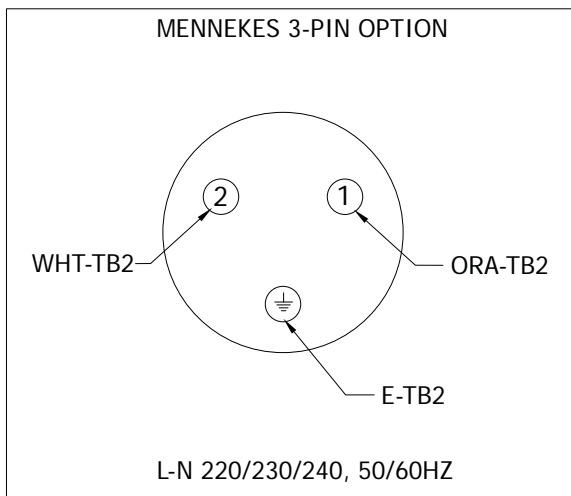
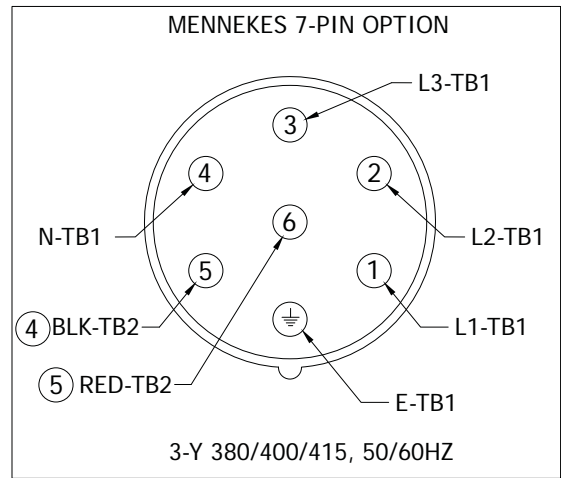
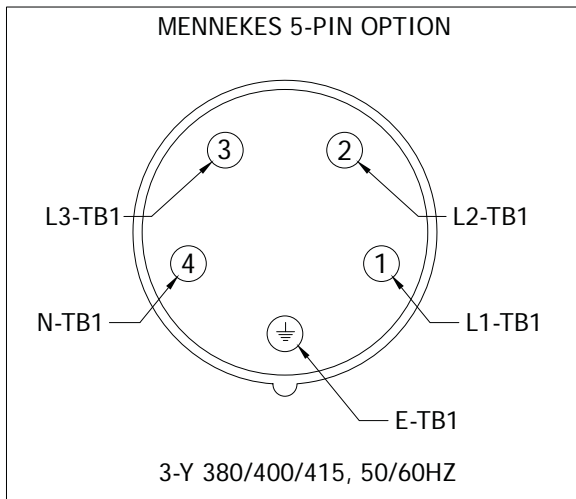

## Terminal Blocks Diagram

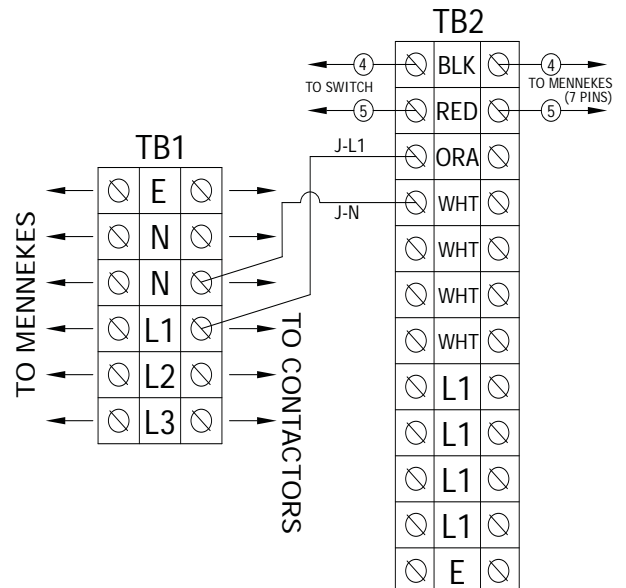

# INSTALLATION & START UP *(continued)*

9. Install Optional Front Gas connection (If available).

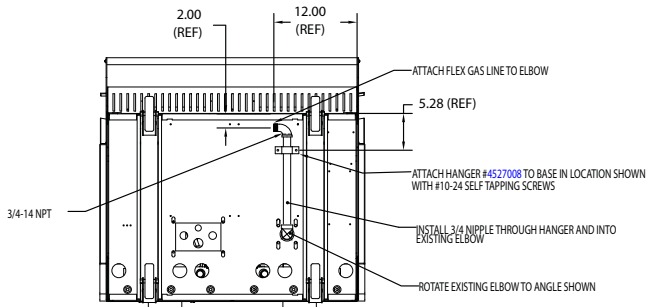

- Isolate grill from any power source by unplugging all electrical connections.
- Rotate existing elbow as shown in the diagram below.
- Attach support bracket (PN 4528775) to base as shown with #10-24 screws and lock washers supplied.

**NOTE: For retrofit applications, drill 2x .161 holes and use self tapping screws provided.**

- Install 3/4" NPT nipple through support bracket and onto existing elbow. Attach locking ring with 2x #10-24 screws.
- Install elbow to orientation show below.
- Install nipple.
- Attach flex gas hose to nipple.

**10. GAS GRILL ONLY, (for electric grills, skip steps 7 & 8):** Install the included quick-disconnect gas hose to the inlet fitting on the underside of the grill by threading a 3/4" NPT nipple into the elbow, then install the brass male quick-disconnect coupler included with the hose.

Connect the hose and ensure the sleeve snaps fully forward against the retaining ring.

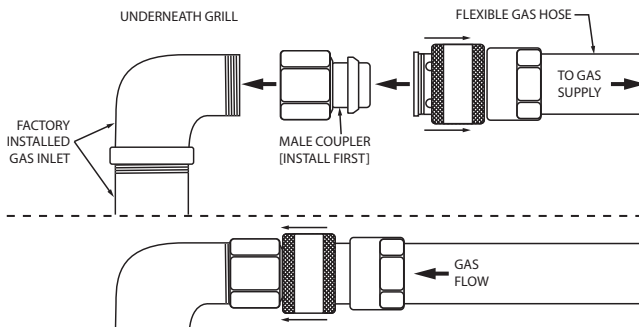

With the manual shut-off valve closed, install the other end of the hose to the gas supply.

11. Install grease bucket rails as shown below:

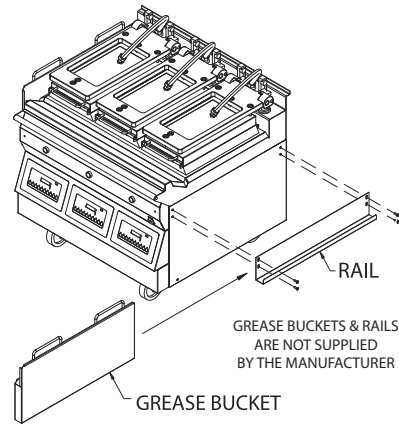

12. Install flue box to back of grill.

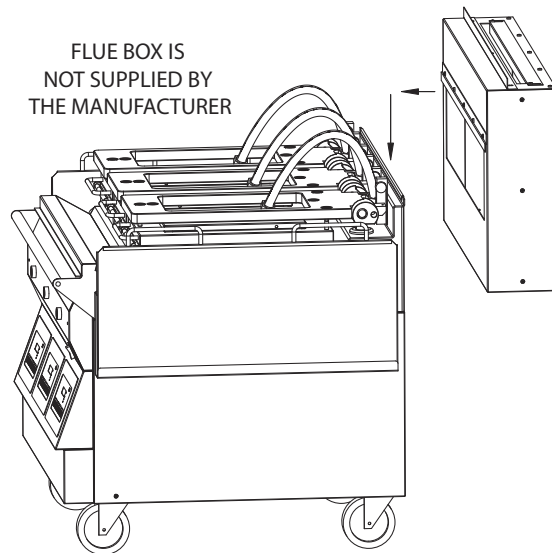

13. Roll grill under exhaust hood. Grill must be level front to back, side to side and diagonally. Adjust casters accordingly to obtain final level.

### Exhaust hood Type & Platen Height

With the platens in the raised position, measure the height from the front edge of the platen to the grill surface. Determine which type of exhaust hood the store has and check for exhaust hood type/platen height compatibility according to the table below:

Exhaust hood TYPE	CORRECT PLATEN HEIGHT
Universal	18 1/2" (470mm)
92 Series	17" (432mm)
GSC	18 1/2" (470mm)

## INSTALLATION & START UP *(continued)*

If the platen height is incompatible with the exhaust hood type, platen height must be adjusted by an authorized service agent.

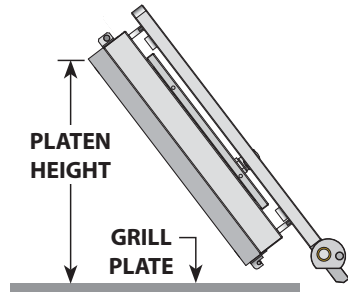







### LonWorks Information & Commissioning

To Activate the grill onto the Lonworks network:

To enable the power line communications between the grill and the Lonworks network the grill must first be commissioned onto the network.

During the commissioning of a Grill onto a Lonworks network the grill has to first send a service pin request message from the grill to the Lonworks server.

The grill sends this message by following the below procedure on the front control panel control of the grill.

1. Power up grill.
2. PRESS and HOLD the  button for approximately 3 seconds. Controller will display previously selected menu item and its corresponding item number.
3. PRESS the  AND  arrow buttons TOGETHER. "CONFIGURE" will appear in the display.
4. PRESS the  arrow button. "SERVICE" will appear in the display. PRESS the  button.
5. Press the  arrow button 2X. "Lonworks Service" will appear in the display.
6. PRESS the  button.
7. Set option to "NO". Wait 10 seconds. If the Lonworks service state was already "ON" make sure this step is done anyway.
8. Set option to "YES". Within 10 seconds the network will receive the Lonworks Service Pin Request.

After the grill service pin request has been sent the Lonworks administrator will detect the service pin message and assign an appropriate address to the grill to enable communications.

After the Lonworks server has established this address the communications will be activated by the Lonworks administrator and the grill will start communicating on the Lonworks Network.

### Setting the Proper Combustion Levels

In order to maintain proper combustion levels, the measurement of uA is not required. Using the following procedure will ensure that the proper O<sub>2</sub>, CO<sub>2</sub>, & CO levels are reached. Combustion level checks and adjustments should only be performed by a qualified technician employed by a factory authorized service center.

1. Remove control panel and lower panel. Set on floor leaving all connections in place.
2. The regulator comes set at 3.5"WC (0.864 KPA) from the factory. Verify pressure is consistent at 3.5"WC.
3. Slightly loosen nut holding butterfly air shutter adjuster on the combustion air blower connected to the burner being adjusted just enough that it can be rotated but will stay in place when force is removed.



4. From a cold start, turn on the zone (burner) and allow it to run for 30 seconds to a minute. Or with a heated zone, place a load on the grill surface to keep the burner operating for a couple of minutes. Adjust the air shutter to reduce the air to the point that the flame on the burner begins to lift and dance off of the burner surface.

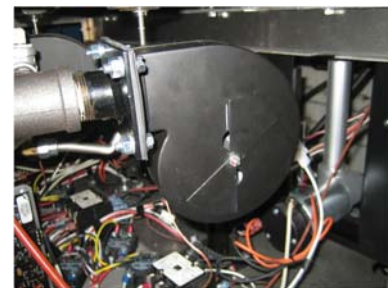

## INSTALLATION & START UP *(continued)*

- a. Mark a line along the edge of the air shutter from the hole along the edge of the shutter marking the position of the shutter on the side of the blower face.
  - b. If this condition already exists, mark the line at the position and move to the next step
- 
5. Rotate the air shutter open to the point that the flame loses its inner light blue cone and becomes less bright and the tip of the flame elongates and becomes about an inch (25.4 mm) long. Mark a line on the edge of the shutter at this position.
- Or if air shutter is fully open, mark the line at that point.



6. Turn off Burner (zone) and measure the distance between the outside ends of the two lines previously marked and place another mark in the center of the two marks.
- a. Add another mark 1/16" (1.6mm) more than the center mark
  - b. Rotate the butterfly shutter to this point, and retighten.

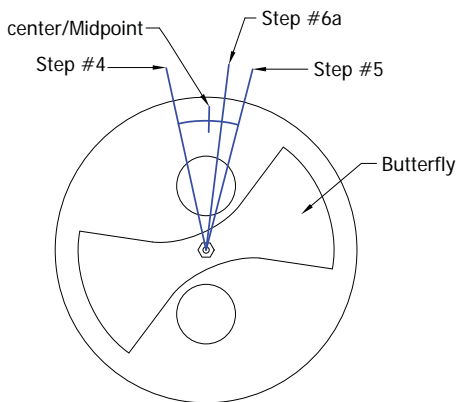

### Start-up Procedure

This Garland 3-platen grill comes with a factory start-up at no additional charge. A start-up is required to take place **BEFORE** the unit is put into operation. It is the end-user responsibility to schedule the start-up with their local Factory Authorized Service Agent, or notify Garland Commercial Ranges at 1-800-446-8367 should you need assistance scheduling.

A factory start-up is a comprehensive grill check in which a factory certified technician will document all final settings programmed in the controller once various other performance checks are complete. The estimated time to complete a start-up is approximately 2.5 – 3.5 hours. Please keep in mind this estimated time when scheduling the start-up. After hours or overtime is not covered under warranty and will be billed at a charge which is the difference between the Garland Reimbursement rate and the Factory Authorized Service Centers overtime charges.

A factory start-up is necessary to start the warranty period. The Authorized Service Center is required to complete the paperwork during the start-up process, and send it to Garland Commercial Industries for reimbursement. At the time of receipt, Garland will start the warranty period which will conclude at the end of 2 years.

# INSTALLATION & START UP *(continued)*

### GARLAND CLAMSHELL GRILL START – UP FORM

**ELECTRIC OR COMBINATION GAS / ELECTRIC**

McDonald's \_\_\_\_\_ Certification ID # \_\_\_\_\_ Store # \_\_\_\_\_ Model \_\_\_\_\_  
Located on Certification Sticker (TICK ONE)

Address \_\_\_\_\_ City \_\_\_\_\_

State / Province \_\_\_\_\_ Zip Code \_\_\_\_\_ Serial# \_\_\_\_\_ Start Up Date \_\_\_\_\_  
(MM/DD/YYYY)

United States  Canada  International (List Country) Telephone # \_\_\_\_\_

<input type="checkbox"/> MWE3W-1	<input type="checkbox"/> MWG3W-1	<input type="checkbox"/> MWE3S-1
<input type="checkbox"/> MWE3W	<input type="checkbox"/> MWG3W	<input type="checkbox"/> MWE3S
<input type="checkbox"/> MWE2W-1	<input type="checkbox"/> MWG2W-1	<input type="checkbox"/> MWE2S-1
<input type="checkbox"/> MWE2W	<input type="checkbox"/> MWG2W	<input type="checkbox"/> MWE2S
<input type="checkbox"/> MWE1W-1	<input type="checkbox"/> MWG1W-1	<input type="checkbox"/> MWE1S-1
<input type="checkbox"/> MWE1W	<input type="checkbox"/> MWG1W	<input type="checkbox"/> MWE1S

Gas Type	Electric / 3-phase	Record Amps Per Line Each Contactor		
Actual Gas Type _____	Actual Input _____ V / _____ Hz	Left	Center (If Applicable)	Right (If Applicable)
Matches Rating Plate? YES NO	<input type="checkbox"/> 208 VAC <input type="checkbox"/> 380 VAC <input type="checkbox"/> 220 VAC <input type="checkbox"/> 400 VAC <input type="checkbox"/> 230 VAC <input type="checkbox"/> 415 VAC <input type="checkbox"/> 240 VAC	Line 1		
	<input type="checkbox"/> 60 Hz <input type="checkbox"/> 50 Hz	Line 2		
		Line 3		

**INSPECTION / OPERATIONAL CHECK**

**NOTE1: CENTER(C) PLATEN should not be checked if MWE2W / MWG2W / MWE2S**  
**NOTE2: CENTER(C) & RIGHT(R) PLATEN should not be checked if MWE1W / MWG1W / MWE1S**

1. To avoid personal injury or property damage, <b>Check for Gas Leaks</b> through the entire gas line.	<input type="checkbox"/> PASSED – NO GAS LEAKS
2. Ensure equipment restraint devices are installed correctly according to local codes (Gas & Electric). Note: part supplied by others.	<input type="checkbox"/> OK
3. Verify, power cord has a strain relief attached from power supply cord to grill unit.	<input type="checkbox"/> YES / <input type="checkbox"/> NO
4. Ensure grill is installed in the proper type of <b>Gas Exhaust Hood</b> with the proper air draw.	<input type="checkbox"/> OK
5. Ensure flue restrictors are fully opened or removed. Flue Box Supplied by KES Flue Restrictors located inside exhaust hood	<input type="checkbox"/> OK <input type="checkbox"/> OK
6. Ensure bottom plate is leveled side to side / front to back / diagonally, in location, under hood. <b>Adjust casters to attain level.</b> <b>REMOVE GRILL FROM UNDER THE HOOD.</b> Turn Power Switch ON, controller displays are active. <b>Controller displays "OFF"</b> . All platen raises automatically?	<input type="checkbox"/> OK   <input type="checkbox"/> OK   <input type="checkbox"/> R   <input type="checkbox"/> OK
8. Lower and raise Upper Platen and ensure movement is smooth and continuous. Grease shafts accordingly with a FOOD GRADE LUBRICANT.	<input type="checkbox"/> OK   <input type="checkbox"/> OK   <input type="checkbox"/> R   <input type="checkbox"/> OK
9. If upper platen elevation requires lowered to allow for clearance of hood, lower upper limit switch. Refer to Operations & Installation manual for platen heights.	<input type="checkbox"/> OK   <input type="checkbox"/> OK   <input type="checkbox"/> R   <input type="checkbox"/> OK
10. Press the POWER ON button. Controller displays "PREHEAT - AM"; platen lowers. Heat indicator lights are AMBER?	<input type="checkbox"/> OK   <input type="checkbox"/> OK   <input type="checkbox"/> R   <input type="checkbox"/> OK
11. Press and hold the AM / PM key and set to PM. This will allow the unit to heat to Platen -425°F(217°C), Grill-350°F(177°C) for a grill with full default settings.	<input type="checkbox"/> OK   <input type="checkbox"/> OK   <input type="checkbox"/> R   <input type="checkbox"/> OK
12. Ensure grill enters SOAK mode (15:00 timer), counts down and upper platen auto calibrates while at temperature.	<input type="checkbox"/> OK   <input type="checkbox"/> OK   <input type="checkbox"/> R   <input type="checkbox"/> OK
13. Close valve handle and verify the unit tries to ignite three (3) times and then locks out because of Ignition Failure?	<input type="checkbox"/> OK   <input type="checkbox"/> OK   <input type="checkbox"/> R   <input type="checkbox"/> OK
14. GAS PRESSURE CHECKS (if applicable): (Note 1: Center should not be fill if MWG2W / MWG2W-1) (Note 2: Center & Right should not be fill if MWG1W / MWG1W-1)	
Rated Incoming Pressure <input type="checkbox"/> Natural Gas: 6" – 14" W.C. <input type="checkbox"/> Propane / Butane Gas: 11 – 14" W.C.    Actual Incoming _____" W.C.	
Rated Burner Pressure    Natural Gas <input type="checkbox"/> 3.5" W.C.    Actual Left _____ Center _____ Right _____	
Propane Gas <input type="checkbox"/> 3.5" W.C. for MWG3W/MWG3W-1    Actual Left _____ Center _____ Right _____	
<input type="checkbox"/> 10" W.C. for MWG2W/MWG2W-1 MWG1W/MWG1W-1	
15. Check micro amp reading on flame sense to ensure operating micro amps ARE NO LESS THAN <b>0.8 uA</b> on all burners, unless the grill is equipped with a CE certified ignition module, in which case the minimum is <b>2.0 uA</b> .	<input type="checkbox"/> OK Micro-amps Reading = _____
16. Upon Completion of auto calibration, platen raised automatically, and display reads "READY" If upon completion of auto calibration process, upper platen does not raise, indicate message on controller. Check platen level and adjust reed switches. Cycle power and retry.	<input type="checkbox"/> OK - L / <input type="checkbox"/> C / <input type="checkbox"/> R Check Platen Level - L / <input type="checkbox"/> C / <input type="checkbox"/> R Check Reed Switch - L / <input type="checkbox"/> C / <input type="checkbox"/> R
17. Select menu item "10:1 – CLAM". Verify set temperature is reached and LED lights turn GREEN.	<input type="checkbox"/> OK   <input type="checkbox"/> OK   <input type="checkbox"/> R   <input type="checkbox"/> OK
18. Initiate cook cycle by pushing the GREEN BUTTON. Platen lowers, and timing cycle begins.	<input type="checkbox"/> OK   <input type="checkbox"/> OK   <input type="checkbox"/> R   <input type="checkbox"/> OK
19. Ensure the stores pyrometer is accurate and calibrated using the ice bath method.	<input type="checkbox"/> OK
20. Perform PROBE CALIBRATION.	<input type="checkbox"/> OK   <input type="checkbox"/> OK   <input type="checkbox"/> R   <input type="checkbox"/> OK
21. Perform Platen Leveling procedure & Reed Switch Calibration in "LEVEL / REED SW" mode.	<input type="checkbox"/> OK   <input type="checkbox"/> OK   <input type="checkbox"/> R   <input type="checkbox"/> OK
22. Ensure grill performs successful Auto Calibration upon completion of reed switch calibration.	<input type="checkbox"/> OK   <input type="checkbox"/> OK   <input type="checkbox"/> R   <input type="checkbox"/> OK
23. Lock down all caps. Ensure that the lock nuts do not turn any of the adjuster nuts when tightening.	<input type="checkbox"/> OK   <input type="checkbox"/> OK   <input type="checkbox"/> R   <input type="checkbox"/> OK
24. Assist or obtain assistance with store personnel for <b>Beef/Chicken Integrity Testing</b> , testing product 10:1, 4:1, Angus, Grill Chicken until desired internal product temperatures are met and record cook time (Product cook times chart below).	<input type="checkbox"/> OK   <input type="checkbox"/> OK   <input type="checkbox"/> R   <input type="checkbox"/> OK

Product Cook Times			
	LEFT	CENTER (If Applicable)	RIGHT (If Applicable)
10:1			
4:1			
ANGUS			
GRILL CHICKEN			

Beef Integrity Product	
Manual Mode	<input type="checkbox"/> OK
Tested Auto Mode	<input type="checkbox"/> OK

Problems / Special Circumstances / Damage: \_\_\_\_\_

Submitted by:	Accepted by:
Name: _____	Name: _____
Service Agency: _____	Have you been adequately informed of the operation of the grill, its uses and its general operation? <input type="checkbox"/> YES   <input type="checkbox"/> NO – Indicate comments _____
Sub Agent: (If Applicable) _____	_____
Have you trained store personnel on the operation of the grill? <b>YES / NO</b>	_____
Are you a factory certified technician? <b>YES / NO</b>	_____
Date of Certification (MM/DD/YY)	_____

Visit our <https://clamshell.garland-group.com> for Literature & Documentation

White Copy – Factory                      Yellow Copy – Service Agency                      Pink Copy – Customer

# TEMPERATURE PROBE CALIBRATION

## Monthly Calibration/Verification of Grill Temperature Zones



### HOT SURFACE

Grill Temperatures Will Cause Severe Burns



#### Overview

**Reason:** To Maintain Accurate Grill Temperature Zones.

**Models:** MWG3W-1, MWE3W-1, MWE3S-1.

**Tools:** Digital Pyrometer with Surface Probe.

#### Procedures:

1. Temperature Verification Procedure.
2. Temperature Calibration Procedure.

#### WARNING:



**PERSONAL INJURY FROM BURNS MAY RESULT WHEN COMING IN CONTACT WITH HOT COOKING SURFACES.**

#### NOTE:

1. CALIBRATION AND VERIFICATION OF GRILL IS DONE WITH RELEASE MATERIAL SHEETS "OFF".
2. MUST CLEAN GRILL PLATE AND PLATEN SURFACES.

### 1. Temperature Verification Procedure

**PLEASE FOLLOW THESE INSTRUCTIONS EXACTLY AS THEY APPEAR BELOW:**

1. The upper platens and lower grill plate should be at operating temperatures to perform this calibration procedure. Press the  or  button to select a "CLAM" operation that requires a temp of 350°F (177°C) on the griddle plate and allow the grill to reach the set temperature and stabilize, (approximately 30 minutes).
2. Press and hold the temperature button for approximately 3 seconds, or until the controller will display all temperature values (T,F,M,B).
3. Place pyrometer over the marks on grill plate indicating thermocouple location (see sketches on next pages). Allow at least 5 to 10 seconds for the pyrometer to respond and stabilize.
4. Check calibration for each heat zone when the following conditions occur:
  - A. The temperature indicator light for the specific thermocouple is GREEN.
  - B. Temperature read out for a specific thermocouple on the control is decreasing.
  - C. **Optimum range for VERIFICATION is between 355F (180C) and 350F (177C).** This procedure can require up to 10 minutes, depending on the point in time the operator gets in the heat cycle

#### IMPORTANT NOTE:

For **3 Platen Gas Grill**, value B on the controller display represents the thermocouple on the middle plate.















# TEMPERATURE PROBE CALIBRATION

## Monthly Calibration/Verification of Grill Temperature Zones

5. Temperature delta between pyrometer and controller must be +/-5F (+/-3C). If the temperature delta between pyrometer and controller is more than +/-5F (+/-3C) go to TEMPERATURE CALIBRATION PROCEDURE to correct required zone.

### 2. Temperature Calibration Procedure

#### PLEASE FOLLOW THESE INSTRUCTIONS EXACTLY AS THEY APPEAR BELOW:

- The upper platens and lower grill plate should be at operating temperatures to perform this calibration procedure. Press the  or  button to select a "CLAM" operation that requires a temp of 350° (177°C) on the griddle plate and allow the grill to reach the set temperature and stabilize, (approximately 30 minutes).
  - PRESS and HOLD the  button for approximately 3 seconds, or until the controller will display: "PROBE CAL"
  - PRESS the  button to display the first temperature zone to be calibrated. The first zone to be calibrated is "FRONT TEMP CAL". The zones are displayed in order of FRONT TEMP CAL, MIDDLE TEMP CAL, BACK TEMP CAL, TOP TEMP CAL.
  - Select a heat zone display using the  or  buttons.
  - Place pyrometer over the marks on grill plate indicating thermocouple location (see sketches on next pages). Allow at least 5 to 10 seconds for the pyrometer to respond and stabilize. Note the temperature on the pyrometer.
- IMPORTANT NOTE:**  
Optimum range for CALIBRATION is between 355F (180C) and 350F (177C). This procedure can require up to 10 minutes, depending on the point in time the operator gets in the PROBE CAL.
- Adjust the temperature on the grill control accordingly to match the temperature on the pyrometer. The  button will increase the displayed temperature in one, (1) degree increments. The  button will decrease the displayed temperature in one, (1), degree Increments.
- NOTE: During step 6, the control should be sounding a high-pitched tone. The temperature can only be adjusted if this tone is sounding and display flashing. If the control is silent and display not flashing, the temperature will not change.**
- As soon as you have a temperature match PRESS the  button to lock the calibrated temperature into the controller.
- Note: If calibration window is missed, press  to go back to the previous step.**
-  = Exits function without any modification, as long as  button has not been pressed.**
- Press the  or  button to select the next heat zone.
  - Move the pyrometer's surface probe to the newly selected heat zone and repeat steps 5, 6, and 7.
- IMPORTANT NOTE:**  
For 3 Platen Gas Grill, value B on the controller display represents the thermocouple on the middle plate.
- Repeat the procedure for each of the heat zones.
- Exit the program mode by pressing the  button. The controller will return to its previous state in the Normal Operating Mode for temperature verification (page 1).

# TEMPERATURE PROBE CALIBRATION

## General Definition of Thermocouples Usage

Grill Models	Quantity of Thermocouples on Grill	Controller Display	Thermocouple Location on Grill Plate	Quantity of Thermocouples on Platen	Thermocouple Location on Platen
MWE3W-1 / MWE3S-1	3	B	Back	1	T = Top Center
		M	Middle		
		F	Front		



Grill Models	Quantity of Thermocouples on Grill	Controller Display	Thermocouple Location on Grill Plate	Quantity of Thermocouples on Platen	Thermocouple Location on Platen
MWG3W-1	1	B	Middle	1	T = Top Center



Note: Temperature reading could be in Fahrenheit or Celsius.

# THERMOCOUPLE LOCATION

## 3 Platen Thermocouple Location of Grill Zones

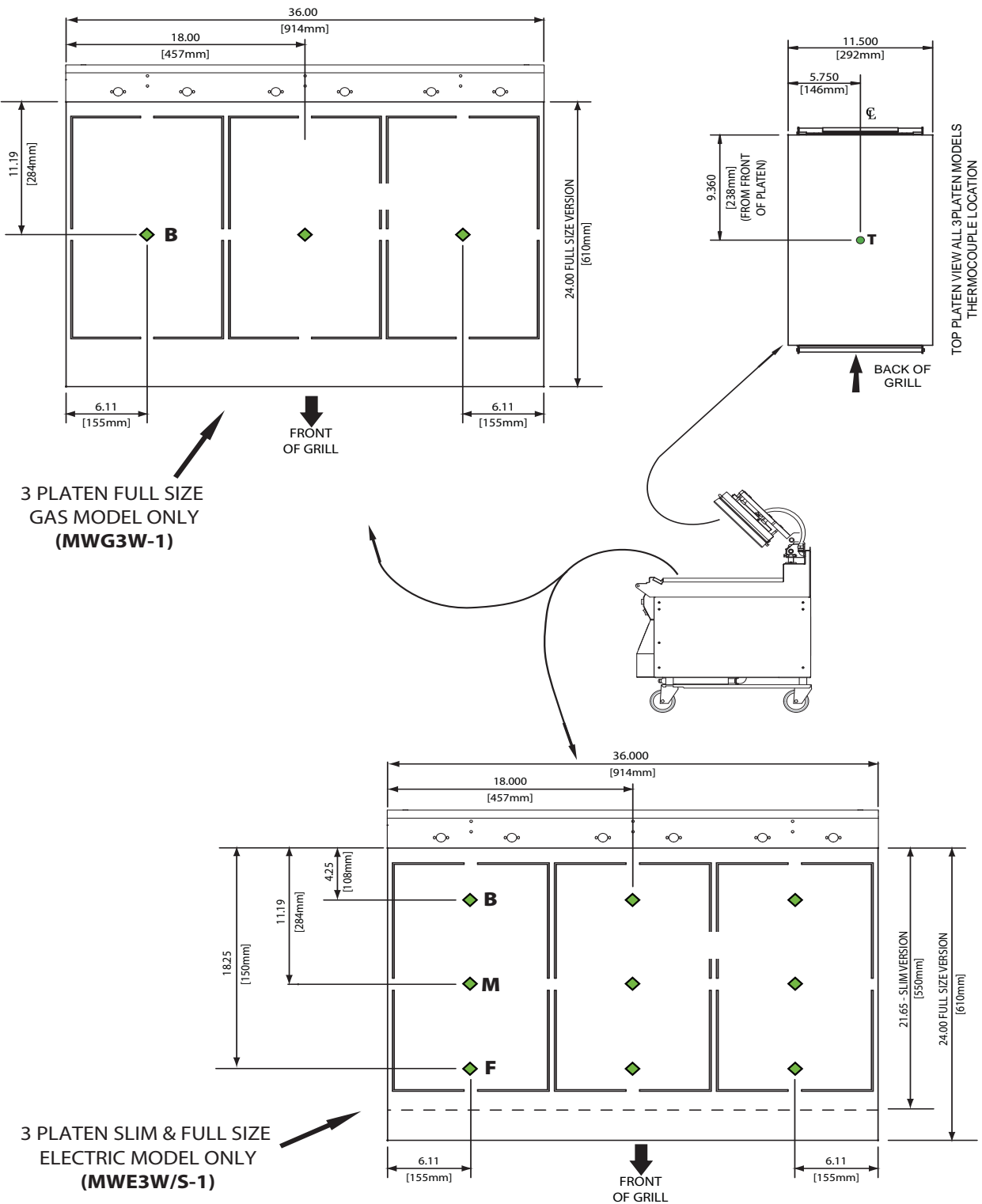

# INSTALLATION OF WRAP AROUND RELEASE MATERIAL MOUNTING BRACKETS

**CAUTION:**

UPPER PLATEN IS EXTREMELY HOT.

**WARNING:**

ISOLATE POWER SOURCE TO PREVENT ELECTRICAL SHOCK.

1. Ensure Electrical Power is unplugged before proceeding to the next step.
2. Loosen two (2) screws from each side of the platen lid.
3. Position side bracket assemblies over screws and insert into place.

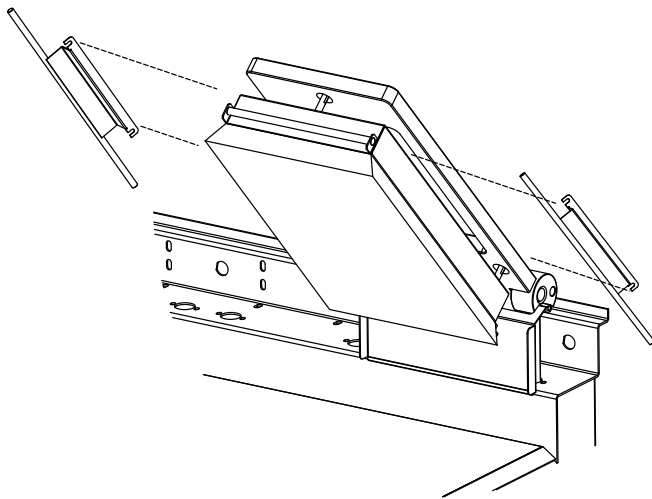

4. Retighten four (4) screws on the platen lid.

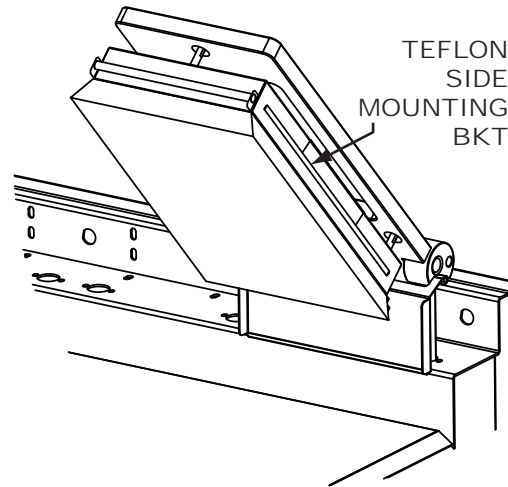

5. Part number and description shown below.

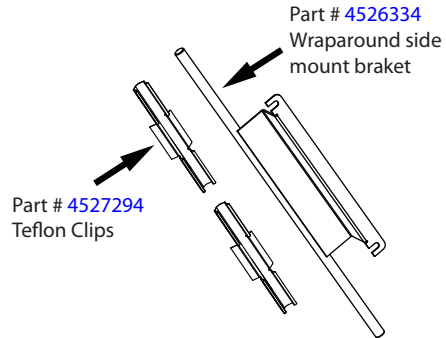

# INSTALLATION OF SPLASH SHIELD

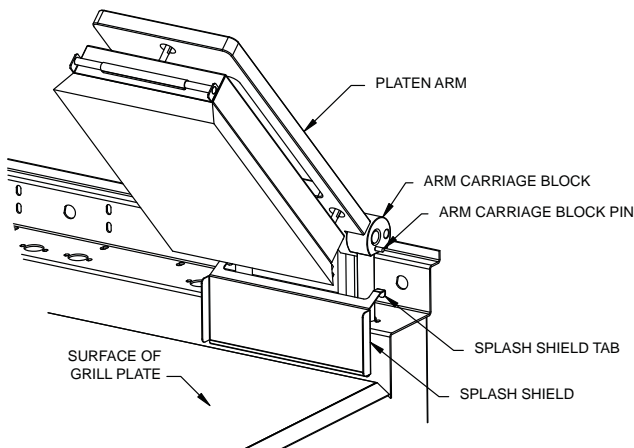

NOTE: SOME COMPONENTS OMITTED FOR CLARITY

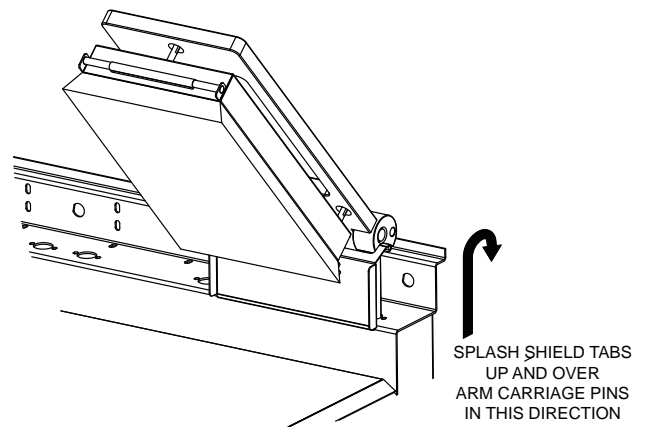

NOTE: SOME COMPONENTS OMITTED FOR CLARITY

# INSTALLATION OF RELEASE MATERIAL

1. Slide release material rod through hemmed end of the Release Material® sheet.
2. Hook Release Material® rod on brackets located at the rear of the upper platen.

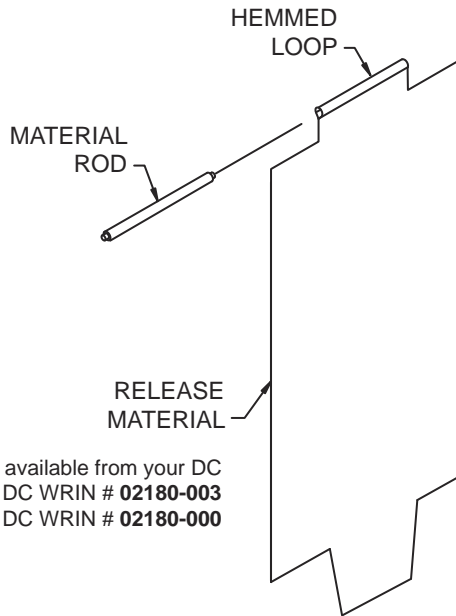

"Teflon Sheet" available from your DC  
 Saint Gobain: DC WRIN # 02180-003  
 Taconic: DC WRIN # 02180-000

3. Holding the bottom of the release material sheet in place, gently pull the sheet toward the front of the platen.

**Note:**  
 Make sure Release Material® fits smoothly over upper platen.

4. Place one (1) locking clip over release material sheet in front and press into place over release material bar.

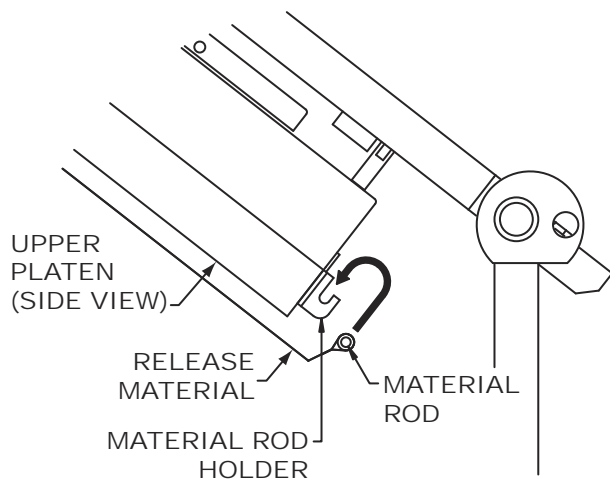

5. Gently pull the release material sheet flap over the left side of the platen and secure in place with two (2) locking clips.

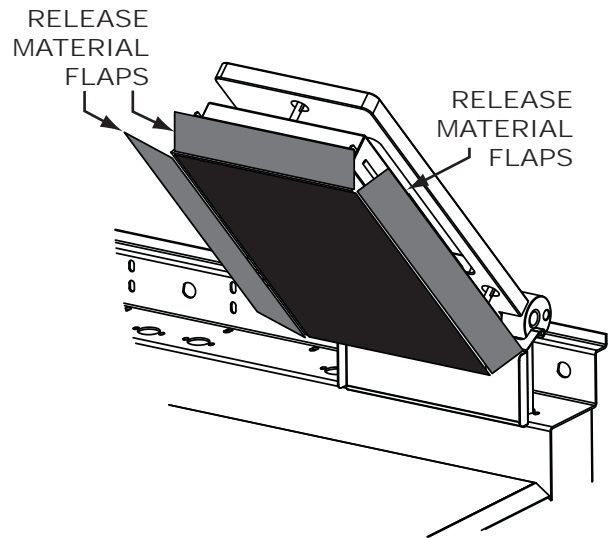

**Note:**  
 Failure to install the correct number of clips on the upper platen will cause the Release Material® to be loose, and wear quickly. Ensure the correct placement of all clips to prevent premature wear and/or poor product quality.

6. Check alignment and tightness of release material against upper platen.

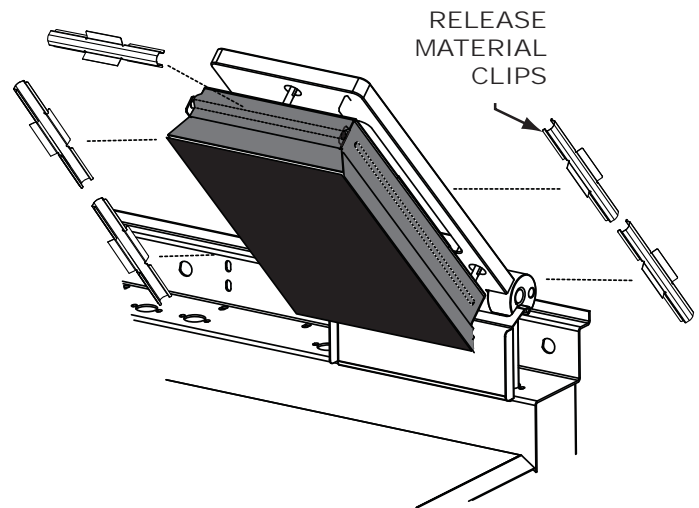

## INSTALLATION OF VAPOR SHIELD

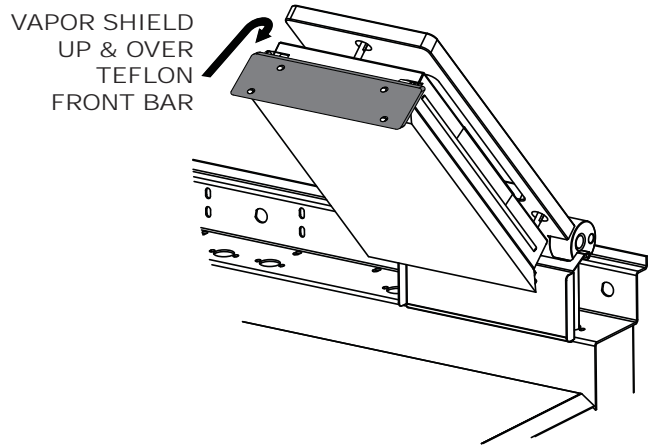
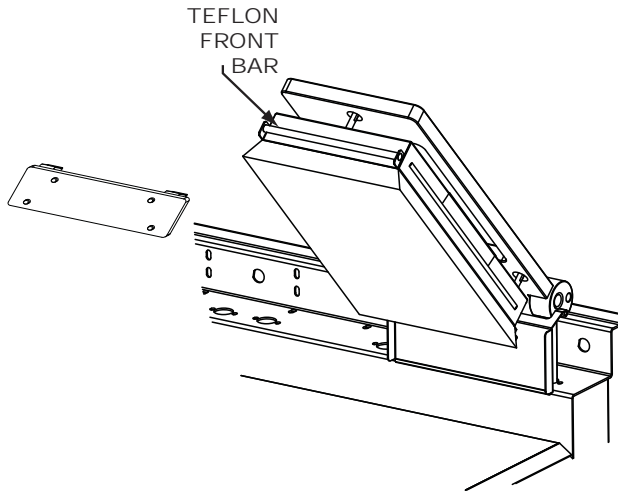

## GRILL ACCESSORIES

**Splash Shield**  
Item [4523492](#)



**Vapor Shield**  
Item [CK4530053](#)

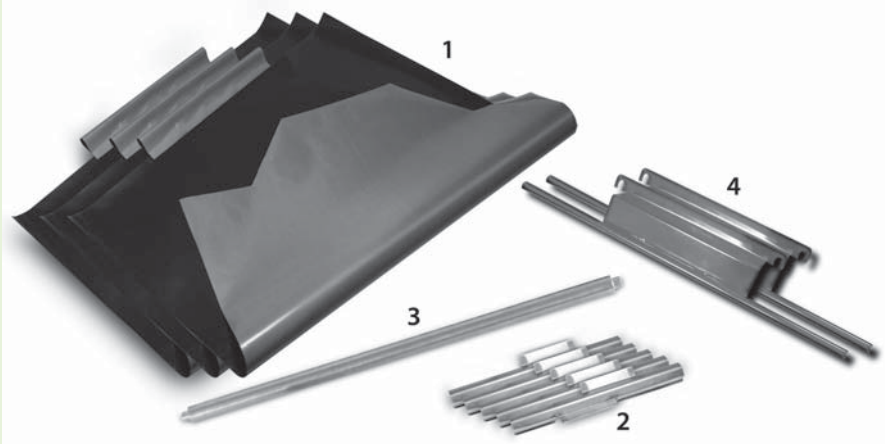

**Platen Teflon Wraparound kit (3 platens)**

	Description	Part #
1	Teflon Sheet (Wraparound)	<a href="#">4527643</a>
2	Clips	<a href="#">4527294</a>
3	Teflon Rear Bar	<a href="#">4521355</a>
4	Side Mount Bracket	<a href="#">4526334</a>

## AVAILABLE ACCESSORIES

BELOW POWER CORDS ARE RECOMMENDED ONLY.  
CORDS APPLY TO APPLICATIONS AND ARE NOT STANDARD.

**3Phase 4Wire 50 AMP Power Cord (Electric Grill ONLY)**  
(No Garland P/N) - \*\*\* Not supplied by Garland

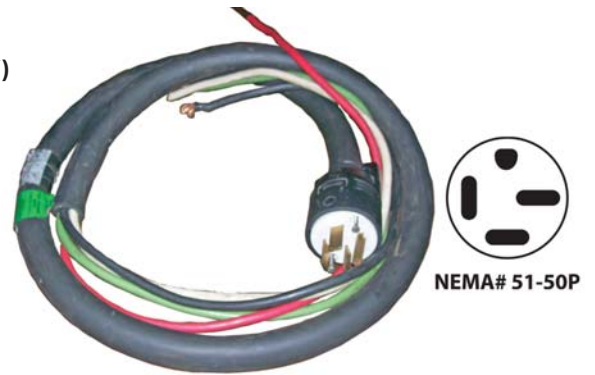

**3Phase 4Wire 30 AMP Power Cord (Electric Grill ONLY)**  
(No Garland P/N) - \*\*\* Not supplied by Garland



**Interlock Cord - 5Wire**  
(No Garland P/N) - \*\*\* Not supplied by Garland

Note:

Power cord not included with the purchase of your new grill from manufacturer.

## AVAILABLE ACCESSORIES

---

---

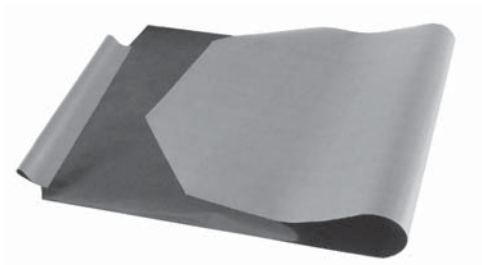

**Platen Teflon Sheet (Not Wraparound)**  
Item [4521792](#)



**Release Material Sheet Rod**  
Item [4526436](#)



**Quick-Disconnect Gas Hose**  
Item [1591506](#)



**Release Material Sheet Retaining Clip**  
Item [4527294](#)



**Lower Teflon Release Sheet**  
Item [4531542](#)

# CLEANING & MAINTENANCE

**Warning:** Pinch Hazard keep hands and tools clear when platens are in motion. Unexpected movement of platens can occur during cleaning or servicing process. Turn Grill Off at main switch when cleaning platen



McD Hi-Temp Grill Cleaner

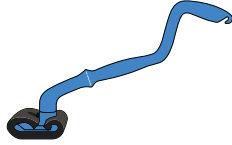

KAY Grill Cleaning Pad Holder & KAY Grill Cleaning Pad

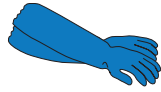

Heat-Resistant Gloves



Clean, Sanitizer-Soaked Grill Cloths



Lid



Grill Squeegee

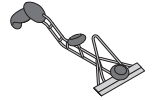

Grill Scraper

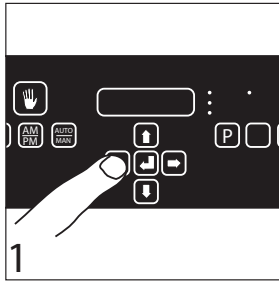

1

- Select Clean Mode. Once Clean Mode has been reached turn each zone OFF.
- Turn main switch **OFF** when cleaning platens

## Warning

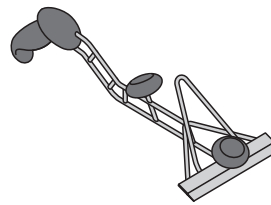

- Following Step has to be performed by using a Grill Scraper approved by McDonald's.
- Failure to use a McDonalds approved scraper may result in grill surface damage.
- **Note:** Never use a steel scraper to clean the upper platens.

## Grill Scraper

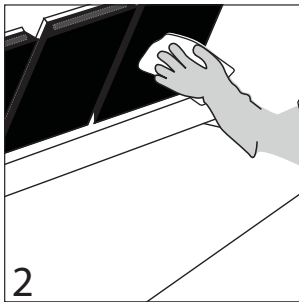

2

- Wipe the Release Material® sheets with a clean, sanitizer-soaked grill cloth.

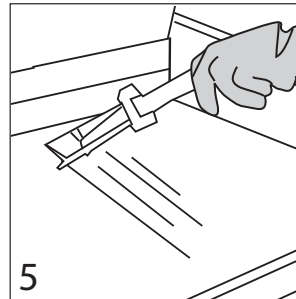

5

- Scrape the lower grill surface with the grill scraper.
- Use grill squeegee to push residual grease into trough.
- Take grill scraper to the 3-compartment sink to be washed and rinsed.

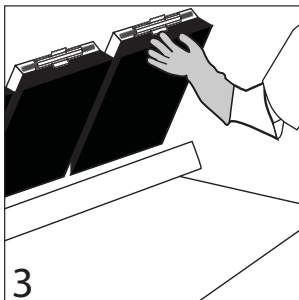

3

- Remove the locking clips, bars, and release Material® sheets.
- Take the clips and bars to the 3-compartment sink to be washed and rinsed; set aside.
- Set release Material® sheets aside on a flat surface.

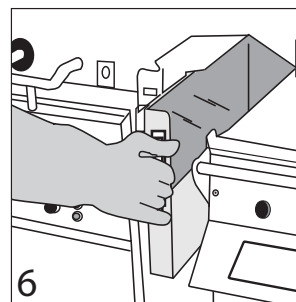

6

- Empty and replace the grease troughs.

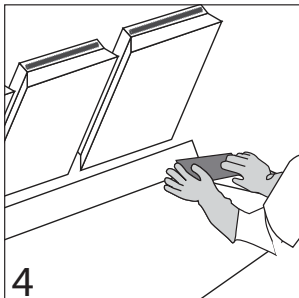

4

- If splash guards are installed, detach and take to the 3-compartment sink to be washed and rinsed; set aside.



7

- Open one packet of McD Hi-Temp Grill Cleaner and empty the contents into a lid or stainless steel pan.
- Put on the heat-resistant gloves and safety glasses..

# CLEANING & MAINTENANCE

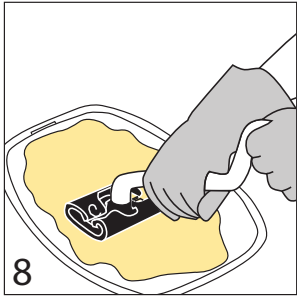

- Dip the KAY Grill Cleaning Pad Holder into the grill cleaner.
- **Note:** Never use a steel scraper to clean the upper platens.

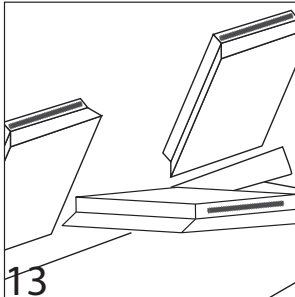

- Turn main switch **ON**.
- Press green button to lower center platen.
- Turn main switch **OFF**

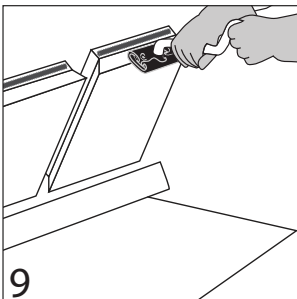

- Apply McD Hi-Temp Grill Cleaner to front side of platens starting from right platen to left platen.
- DO NOT SCRUB

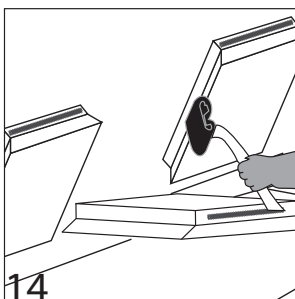

- Apply grill cleaner to inner edges of the right and left platens.
- Apply grill cleaner to side edges of the center platen
- Turn main switch **ON**.
- Press green button to raise right platen.

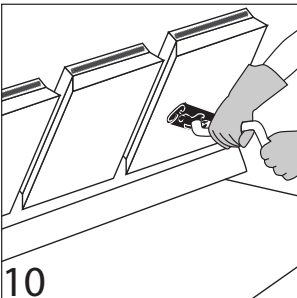

- Apply the grill cleaner to platen surfaces starting from right platen to left platen.
- DO NOT SCRUB

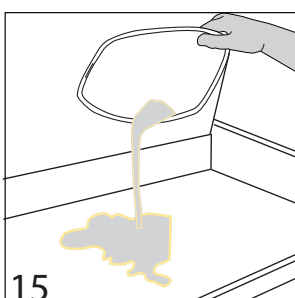

- Turn main switch **OFF**.
- Pour remaining McD Hi-Temp Grill Cleaner over bottom grill surface.

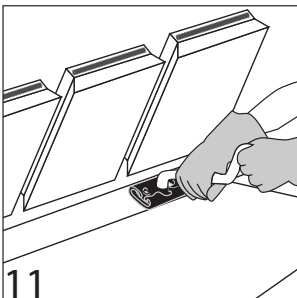

- Apply the grill cleaner to back side of platens from right platen to left platen.
- DO NOT SCRUB

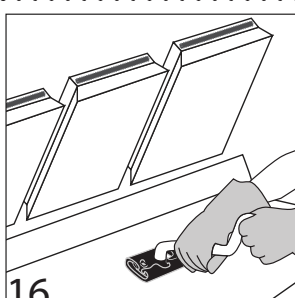

- Spread the cleaner over the entire lower grill surface from front to back using even strokes.
- DO NOT SCRUB

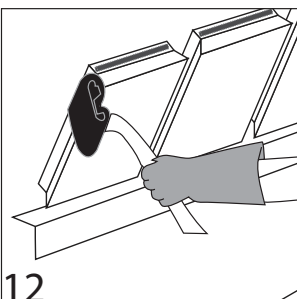

- Apply the grill cleaner to outer edges of right and left platens.
- DO NOT SCRUB

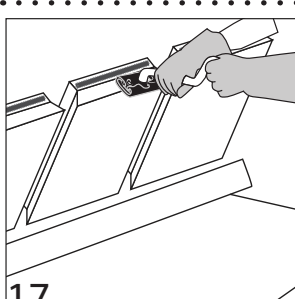

- Start scrubbing now.
- Scrub front side of platens from right platen to left platen with KAY Grill Cleaning Pad Holder and Pad.

# CLEANING & MAINTENANCE

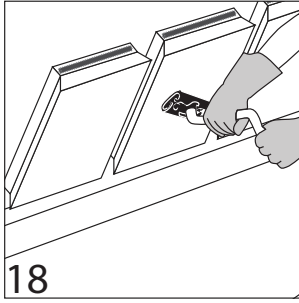

- Scrub flat grill surfaces starting from right platen to left platen.

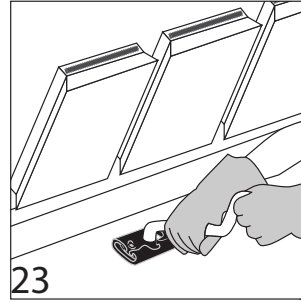

- Turn main switch **OFF**.
- Scrub lower grill surface.

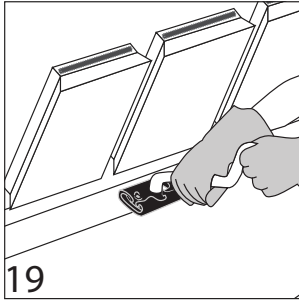

- Scrub back side of platens from right platen to left platen.

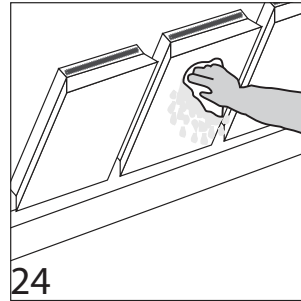

- Rinse front, side and back of platen surfaces with a clean, sanitizer-soaked grill cloth, starting from right to left platens.
- Turn main switch **ON**.

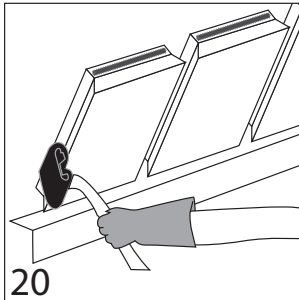

- Scrub outer edges of right and left platens.
- Turn main switch **ON**

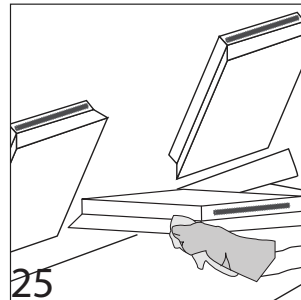

- Press the green button to lower center platen.
- Turn main switch **OFF**.
- Rinse edges of all platens.
- Turn main switch **ON**.
- Raise platen.

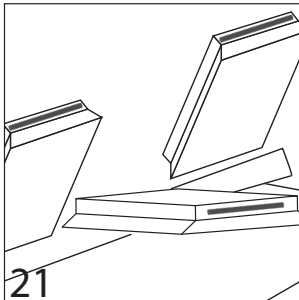

- Press green button to lower center platen
- Turn main switch **OFF**.

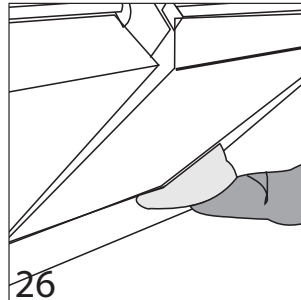

- Turn main switch **OFF**.
- Wipe back of lower grill with a clean, sanitizer-soaked grill cloth.

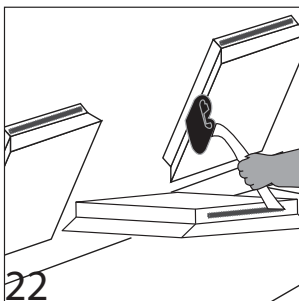

- Scrub inner edges of the right and left platens
- Scrub side edges of the center platen.
- Turn main switch **ON**.
- Press green button to raise the center platen.



- Pour a small amount of lukewarm water on a clean, sanitizer-soaked grill cloth over the bottom grill surface and wipe off residue.

# CLEANING & MAINTENANCE

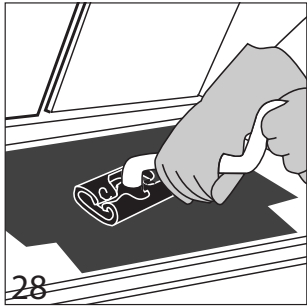

- Place upper platen Release Material sheets flat on grill surface.
- Gently clean both sides of the Release Material sheets with the KAY Grill Cleaning Pad Holder.

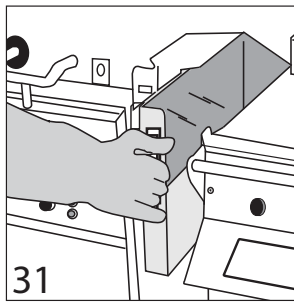

- Empty, wash, rinse, and replace the grease troughs.



- Rinse both sides of the Release Materialsheets with a clean, sanitizer-soaked grill cloth.
- Reinstall upper Release Material sheets; secure in place with bars and clips.

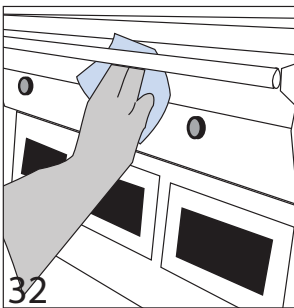

- Wipe remaining grill surfaces with a clean, sanitizer-soaked grill cloth.

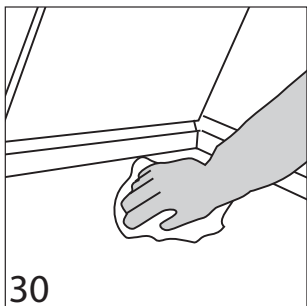

- Wipe lower grill with a clean, sanitizer-soaked grill cloth. Repeat until no visible soil remains.

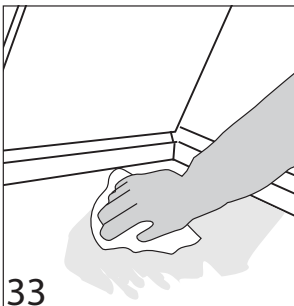

- Apply a thin coat of fresh shortening to the lower grill surface only.

# PULL / PUSH GRILL PROCEDURE

1. Turn main switch ON.
2. Press green button to lower platen(s).
3. Turn main switch OFF.
4. Unplug power cord and proceed with pull/push.



**WARNING,**  
Avoiding procedure may cause damage or loss of calibration on the platen and potential of error message can occur.

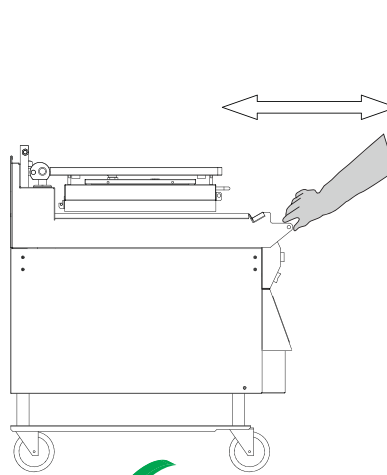

**PASS** – Gently pull or push

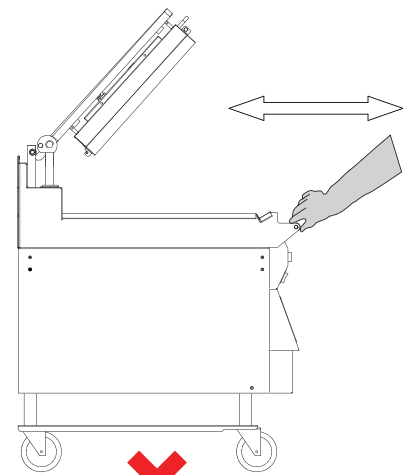

**FAIL** – Potential to damage platen adjustment

# DESCRIPTION OF GRILL CONTROL

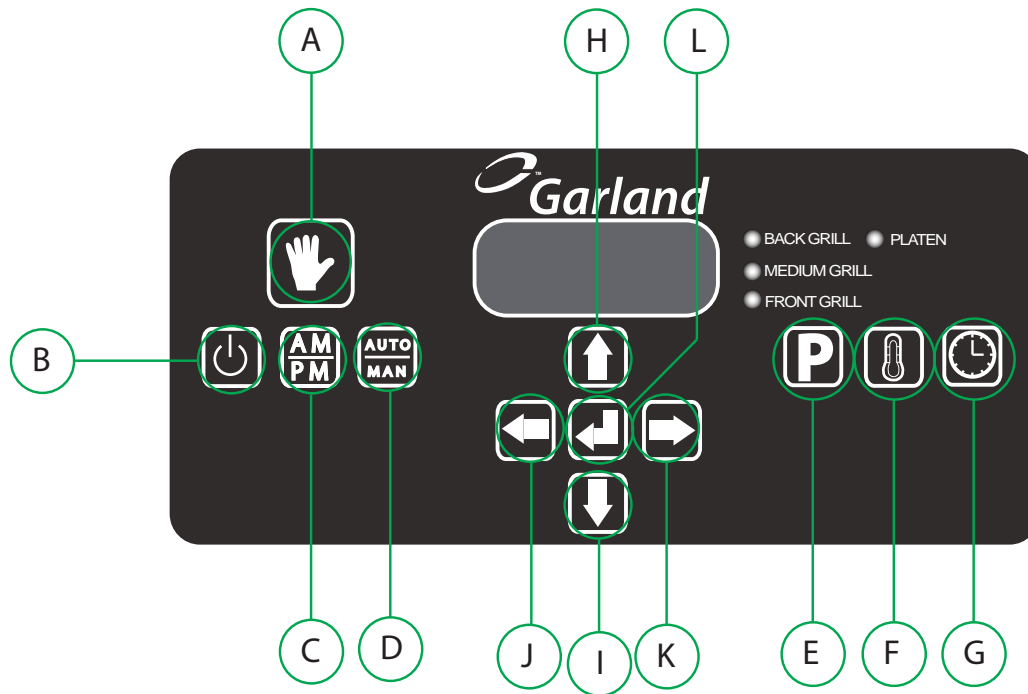

Items	Key Data	Funtions
<b>A</b>	Key A – Standby	Key A will be used to put the control into the Standby mode.
<b>B</b>	Key B – On/Off	Key B will turn the control on and off. PRESSING and HOLDING button for 2 seconds
<b>C</b>	Key C – AM/PM	This button is used to toggle back and forth between the AM menu list and the PM menu list in manual cook mode. In automatic mode this button will toggle between the AM product recognition gaps and the PM product recognition gaps.
<b>D</b>	Key D – Automatic/Manual	Key D will be used to select between Automatic and Manual cooking. Used for product recognition only.
<b>E</b>	Key E – Programming	Key E will allow the user to enter and exit the Programming Mode. PRESSING & HOLDING button for 3 seconds
<b>F</b>	Key F – Temperature	Key F will be used to view the set point and actual temperature of the grill and platen.
<b>G</b>	Key G - Time	Key G will be used to change the remove time of a specific menu item and to calibrate the grill temperatures.
<b>H</b>	Key H – Up Arrow	Key H will scroll up through the menus as well as scroll up in the programming mode.
<b>I</b>	Key I – Down Arrow	Key F will scroll Downs through menus as well as decrement values in the programming mode.
<b>J</b>	Key J – Left Arrow	Key J will be used for scrolling through menus and well as in programming.
<b>K</b>	Key K – Right Arrow	Key K will be used for scrolling through menus and well as in programming.
<b>L</b>	Key L – Enter Function (Menu Select)	Key L will be used to enter new values that have been changed in the programming modes.

LED	Description
Platen	IF the temperature is below set point the LED will be <b>orange</b> , if the temperature is between the set point and 79F LED will be <b>green</b> , if the temperature is set point plus 80F or higher the LED will be <b>red</b> If Platen is disabled LED will be off.
Back Grill	Will work in sequence with the other middle and front grill Heater LED’s. IF the temperature is below set point the LED will be <b>orange</b> , if the temperature is between the set point and 79F LED will be <b>green</b> , if the temperature is set point plus 80F or higher the LED will be <b>red</b> .
Middle Grill	Will work in sequence with the other middle and front grill Heater LED’s. IF the temperature is below set point the LED will be <b>orange</b> , if the temperature is between the set point and 79F LED will be <b>green</b> , if the temperature is set point plus 80F or higher the LED will be <b>red</b> .
Front Grill	Will work in sequence with the other middle and front grill Heater LED’s. IF the temperature is below set point the LED will be <b>orange</b> , if the temperature is between the set point and 79F LED will be <b>green</b> , if the temperature is set point plus 80F or higher the LED will be <b>red</b> .

## ERROR MESSAGING

- Error messages were improved in this latest product release and have now actionable items.
- An error log feature will help technicians with up to 51 different error codes in the troubleshooting process.
- A maximum of 99 error instances can be saved in a non-volatile memory so the information can be read regardless the unit has been powered OFF.
- All new diagnostic features and error information is detailed in service manual.
- Results from latest successful calibration are saved in the Calibration Log under the Service Menu.
- Some examples of more common errors and actions are as follows:

Error Code#	Message on Screen	Possible Meaning	Action
Several	ERROR	Refer to Service Manual	1
21	OBSTRUCTION	Check for object under platen that could jam platen	1
34	ROOM TEMP LOW	Raise room temperature above 32 degrees F / 0 degrees C	2
35	ROOM TEMP HIGH	Lower room temperature to below 176 degrees F / 80 degrees C	2
36	NO IGNITION	Check gas gauge supply for gas models or electric power for electric models	2
Several	GRILL TOO HOT	Temperature high - Allow cool down	1
48	PROD. NOT RECOG	Check object on the grill - Clean grill	1
54	WRONG GRILL TYPE	Gas grill set to electric or viceversa - correct setting	2

### Action to take :

1. Press Green button to recalibrate grill and see if error repeats. if error persist call for service near you area.
2. Turn main switch off and on.

## OPERATION PROCEDURES

### General Overview:

The grill controller will allow for 2 functions, both described in detail in the following sections



The **“Normal Operating Mode”**, also known as the Cook Mode is the mode used during normal cooking. In the normal operating mode, the operator can start a cook cycle, cancel a cook cycle, view actual temperatures, scroll to another menu item, and enter the Programming Mode.

The **“Programming Mode”** is the mode in which the operator can program the controller’s various settings. To enter the programming mode, PRESS and HOLD 

There are currently 3 methods of cooking that can be utilized with the 3 platen Garland clamshell:

**Manual Mode Cooking** – This is the cook method that utilizes a single gap setting for each menu item. The timer will count down according to the selected menu item.

**Multi Stage Cooking** – This method of cooking utilizes 2 different gap settings during the cook cycle. The timer will count down according to the selected menu item.

**Automatic Mode Cooking (Product Recognition)** – The Product Recognition (PR) method of cooking uses the magnetic switches mounted on the upper platen arm assembly to determine the product being cooked. Using the PR feature, the operator simply selects the  button on the controller. Select Automatic Mode; press and hold  button. This will allow the controller to know what product group to select from. When a cook cycle is initiated, the platen will come down and recognize the product being cooked. The cook timer will count down according to the time set for the recognized item. For more information on product Recognition, see the next section; “Product Recognition.”

# OPERATION PROCEDURES

## To turn the grill on:

**The Main Power Switch** – Controls power to the grill and must be turned ON to start operation. The controller displays will be active. Upon successful power up checks, the controllers will display “OFF”.

**AM Operation** – Release Material sheets MUST be ON at this time and the grill surface should be free and clear of carbon.

Once the grill controller displays “OFF” press . The grill controller will go to PREHEAT mode and default to AM preheat temperatures. To preheat to PM temperatures, press and hold .

AM PREHEAT	PM PREHEAT
375°F(190°C)Upper Platen	425°F (218°C) Upper Platen
275°F (135°C) Grill	350°F (177°C) Grill

Upon reaching the AM or PM set temperature (whichever is selected), the grill will stabilize in temperature for fifteen (15) minutes. Once this time has elapsed, the grill will autocalibrate. Upon completion of autocalibration, **the upper platens will raise** to there normal position, and the grill controller will display “READY”.

## To Select a Menu item:

Scroll forward through the list of available menu items by pressing repeatedly. Scroll backward through the list of available menu items by pressing repeatedly.

## Menu Item Library

The menu item library is loaded in the computer based upon the setting programmed in [CONFIGURE]->[GRILL REGION]. Each menu item consists of a function called [DISPLAY ACTIVE]. The settings in this function (AM, PM, AM/PM, No) determine what menu items are displayed when the button is pressed.

Menu Item	Display Active – Default
10:1 - CLAM	PM
4:1 - CLAM	PM
STRIP BACON - CLAM	AM/PM
SAUSAGE CLAM FZN	AM
MCRIB - CLAM	NO
STEAK - CLAM	AM/PM
GRILLED CHICKEN - FLAT	PM
FOLDED EGGS FLAT	AM
ROUND EGGS - FLAT	AM
CHICKEN FLAT BRD - FLAT	NO
10:1 FLAT	NO

4:1 - FLAT	NO
MCRIB - FLAT	NO
SAUSAGE FLAT FZN	NO
HOTCAKES - FLAT	NO
FOLDED EGGS CLAM	AM
ROUND EGGS CLAM	AM
3:1 ANGUS CLAM	PM
MUSHROOMS CLAM	AM/PM
OPT MENU 5 - CLAM	NO
OPT MENU 6 - CLAM	NO
OPT MENU 7 - CLAM	NO
OPT MENU 1 - FLAT	NO
OPT MENU 2 - FLAT	NO
OPT MENU 3 - FLAT	NO
OPT MENU 4 - FLAT	NO

## Indicator Lights

The LED lights on the main control indicate the temperature status of each zone.

**Electric grills** have (4) zones per section , TOP, (platen), BACK GRILL, MIDDLE GRILL, and FRONT GRILL.

**Gas grills** have (2) zones per section , TOP, (platen), and BACK GRILL.

RED – The zone(s) is “TOO HOT” (more than 79°F/43°C over set temperature) OR a heat zone failure has occurred.

AMBER – The zone(s) is calling for heat.

GREEN – The zone(s) is at or above set temperature, but below 79°F/43°C over set temperature.

## To enter the standby mode:



1. Press the button. The upper platen will lower, and in most cases the grill will maintain the grill set point of the last product cooked.

## To Exit the standby Mode:

1. Press the GREEN or ( GREEN & BLACK) push-button(s). The upper platen will raise.





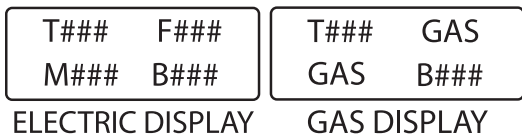

# OPERATION PROCEDURES

## To display the current temperatures:

1. Press the  button and repeat for each zone to be displayed:  
 1st key press – Front Set Point  
 2nd key press – Front Actual  
 3rd key press – Mid Set Point  
 4th key press – Mid Actual  
 5th key press – Back Set Point  
 6th key press – Back Actual  
 7th key press – Platen Set Point  
 8th key press – Platen Actual
2. Pressing and holding the  button for five (3) seconds will display all of the current temperatures at once.









## Breakfast In Manual mode

1. Select AM mode. Press and hold the  button.
2. Select Manual mode. Press and hold the  button.
3. Select a product from the AM product library using the  or  arrow buttons.
4. Following McDonalds procedures for the item selected, load product on the grill.
5. Press the  GREEN or ( GREEN &  BLACK) push-button(s) to initiate a cook cycle.
6. Alarm will sound when the cook cycle is complete.
7. Remove product and clean grill to prepare for the next cook cycle.

## Lunch In Manual mode







**Note:** Switching from breakfast to lunch menu items will take approximately 10 minutes to heat to the appropriate temperatures.

1. Select PM mode. Press and hold the  button.
2. Select Manual mode. Press and hold the  button.
3. Select a product from the PM product library using the  or  arrow buttons.
4. Following the below lay pattern, load product on the grill.
5. Press the  GREEN or ( GREEN &  BLACK) push-





button(s) to initiate a cook cycle.

6. Alarm will sound when the cook cycle is complete
7. Remove product and clean grill to prepare for next cook cycle.

## To Change The Cook Time for a Menu Item





1. Select AM or PM mode. Press and hold the  button.
2. Select Manual mode. Press and hold the  button.
3. Select a product using the  or  arrow buttons.
4. PRESS the  button to display the cook time.
5. Use the  and  buttons to change the cook time.
6. The control will automatically default back to the normal operating mode after 3 seconds.

## Breakfast In Auto mode

1. Select AM mode. Press and hold the  button.
2. Select Auto mode. Press and hold the  button. The control will display “AM / AUTOMATIC”
3. Following McDonalds procedures for the item selected, load product on the grill.
4. Press the  GREEN or ( GREEN &  BLACK) push-button(s) to initiate a cook cycle. The platen will lower, and recognize the product that has been loaded on the grill.
5. Alarm will sound when the cook cycle is complete.
6. Remove product and clean grill to prepare for the next cook cycle.

## Lunch In Auto mode

**Note:** Switching from breakfast to lunch menu items will take approximately 10 minutes to heat to the appropriate temperatures.



1. Select PM mode. Press and hold the  button.
2. Select Auto mode. Press and hold the  button. The control will display “PM / AUTOMATIC.”
3. Following the lay patterns shown on the following page, load product on the grill.
4. Press the  GREEN or ( GREEN &  BLACK) push-button(s) to initiate a cook cycle. The platen will lower, and recognize the product that has been loaded on the grill.

## OPERATION PROCEDURES

5. Alarm will sound when the cook cycle is complete
6. Remove product and clean grill to prepare for next cook cycle.

### Transition Cooking

Approximately 30 minutes before changing to the lunch menu, perform the following:

1. PRESS the  button (to display the upper platen temperature).
2. Press the  button.

3. The upper platen indicator will turn on. The upper platen will heat to 425 degrees F (217 degrees C) the platen will maintain this set temperature unless another menu item is selected.

### To Shutdown Grill





Turn Main Power Switch OFF to disable all burners. For extended periods of shutdown, turn Main Power Switch OFF, close and disconnect main gas and/or electrical connections.

## PRODUCT RECOGNITION

This Garland Clamshell grill is equipped with Product Recognition Controls (PRC) for McDonald's specified select products only. This new technology allows the user to simply start a cook cycle WITHOUT having to select a specific menu item. The PRC will recognize the product thickness by utilizing switches inside the upper platen and the magnets mounted on the platen arms. Once the PRC calculates the thickness of the product that's been loaded, it will look up product from the product range library (below), and automatically select that product. (The minimum and maximum values for applicable product are noted in the Factory Default Setting section near the end of this document.)

While cooking in Automatic Mode, the platen will lower and rest on the top of the product. The platen arms will continue to move in a downward motion performing various calculations to measure the thickness of the product that has been placed. In the event "**Product Not Recognized**" or the wrong product is recognized, perform a Auto Forced Calibration. Performing an Auto Force Calibration will reset the platen to the grill surface.

### TO PERFORM AUTO FORCED CALIBRATION

1. PRESS and HOLD the  and  buttons together. The control will display "AUTO GAP FORCE - NO".
2. PRESS the  button. The "NO" will begin to flash.
3. PRESS the  button. The flashing "NO" will change to flashing "YES".
4. PRESS the  button. **The upper platen will immediately begin to lower and perform an auto calibration routine.**

## COMMON PRODUCT RECOGNITION ISSUES

Product Recognition Errors can appear in 2 ways:

1. After initiating cook cycle, the controller displays "PRODUCT NOT RECOGNIZED - NO RECIPE FOUND".
2. The controller displays the incorrect product for the product that was layed on the grill.

In both cases, the most common reasons for these 2 issues are as follows:

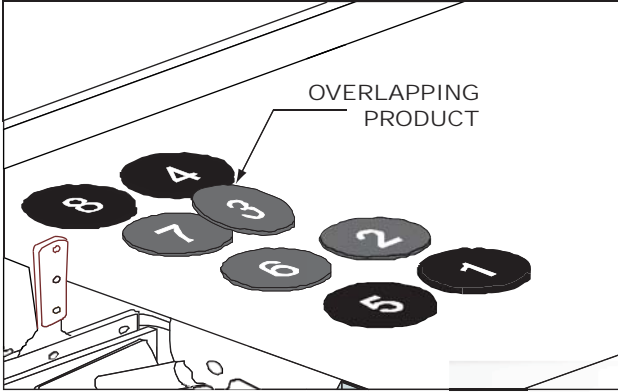
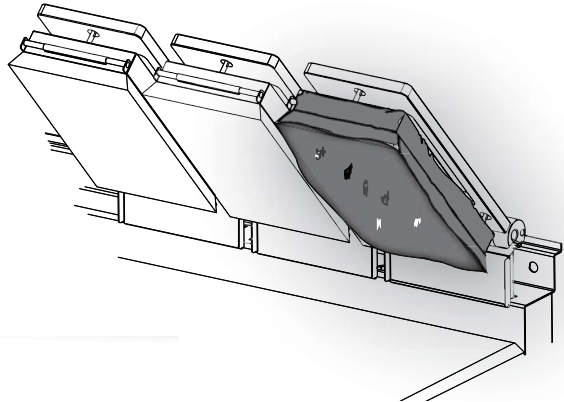
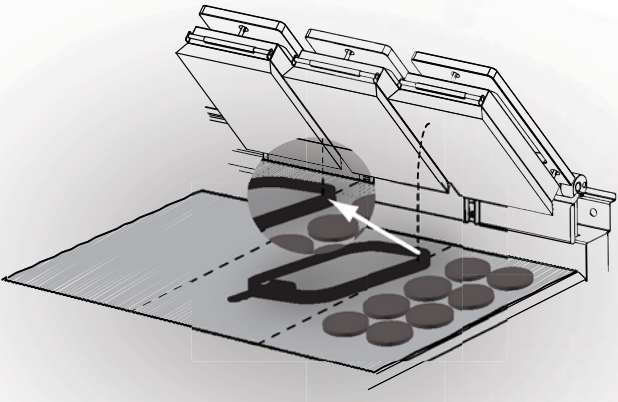
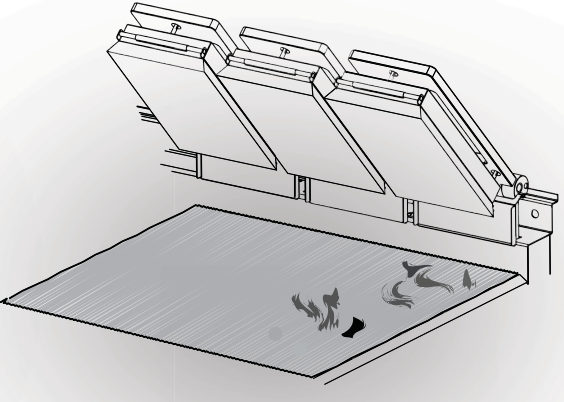
	
<p><b>Overlapping Product</b> - Ensure that you do not have any patties overlapping when you lay product. This will fool the controller into thinking that there is much thicker product on the grill than there is.</p>	<p><b>Wrinkled or Worn Teflon Sheet</b> - Ensure that the teflon sheet is installed and/or wrapped correctly to platen. A loose, worn, or teflon sheet with tears and/or scratches can effect product recognition</p>
	
<p><b>Platen makes contact with Chicken Ring</b> - Always make sure that the chicken ring is clear of the adjacent platen prior to initiating a cook cycle.</p>	<p><b>Auto calibration done with carbon build up or product residue on grill surface</b> - Ensure that the grill surface is free of any carbon build up. Debris on the grill surface during auto calibration will cause the control to mark the location of the grill surface incorrectly</p>

In any of the cases as outlined above or in any other event, perform a Forced Auto Calibration to reset the upper platen distance to the grill surface. Prior to performing a Forced Auto Calibration, be sure to:

1. Make sure the upper platen is free and clear of any carbon build up or debris.
2. Ensure that the grill surface is scraped and cleaned.
3. Teflon sheet should not be worn and be fitted to the upper platen tightly.

Perform a Forced Auto Calibration routine as indicated in section "PRODUCT RECOGNITION", "TO PERFORM FORCED AUTO CALIBRATION".

# PATTY PLACEMENT

This procedure for placement and removal of meat products on the clamshell grill should be followed as indicated below and as follows:

1. Each gray rectangle depicted below represents one cooking area beneath one upper platen.
2. Patties are generally placed two at a time from front to back of grill and right to left.
3. The **removal order** of the patties is shown in the diagrams **by the number shown** in the center of each patty.

**NOTE:**

Patty placement procedures for International Markets may differ. Follow the recommendations of your local McDonald's authorities.

**Maximum patty load per lane:**

- 8 regular (10:1) patties
- 4 angus (3:1) patties (region and country applicable)
- 6 quarter-pound (4:1) patties
- 8 sausage patties
- 6 circular bacon

NOTE: Lay patties 2 at a time, from front to back:

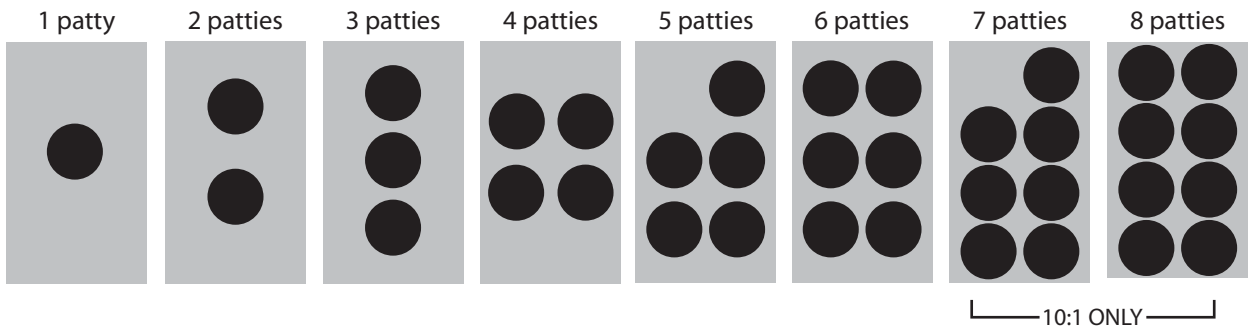

NOTE: Remove the patties in the number ordered shown below:

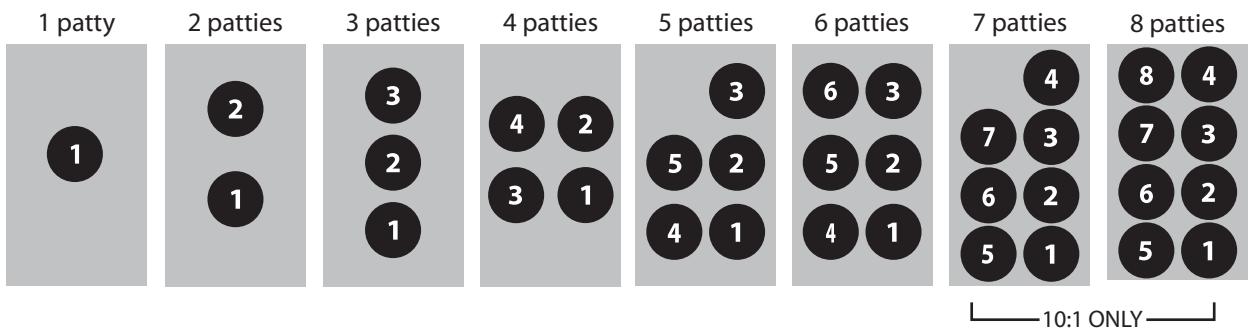

# BEEF INTEGRITY

As shown in the previous page, lay product on the grill in the manner reflected. Product internal temperatures are taken on the corner patties.

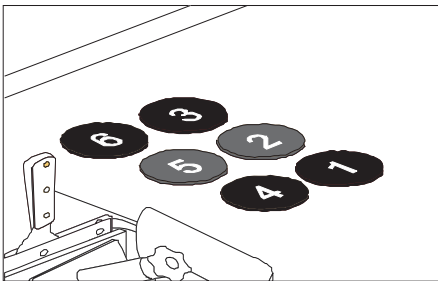
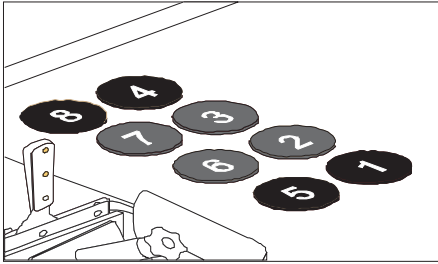

**KEY NOTES:**

- Full runs are always required when performing food safety
- Target removal times are 37 seconds for 10:1's & 107 seconds for 4:1's.
- Seasoning the patties must be done prior to removing the product from the grill..



Cooking grilled chicken utilizes various functions and settings within the controller to ensure proper temperature and integrity.

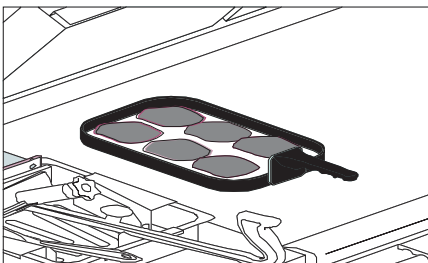

The use of a "Too Cool Flag" is programmed under Menu Item programming. The Too Cool Flag should be set to "ON" in Grilled Chicken & Mushrooms ONLY. In all remaining menu items, the "TOO COOL FLAG" should be turned off.

The "Too Cool Flag" is a function in the control that allows the grill operator to continue to cook approximately 1 additional run of product should the grill be in a "TOO COOL" state prior to the start of a cook cycle, or at the end of a cook cycle

<b>10:1 Patties - Remove in 2 stacks of 4; Probe in center of corner patties (1, 4, 5, 8).</b>	
	<b>Step 1:</b> Using a store calibrated pyrometer, probe the #1 patty (front right corner) in the center of the patty.
	<b>Step 2:</b> Using a store calibrated pyrometer, probe the #4 patty (rear right corner) in the center of the patty.
	<b>Step 3:</b> Using a store calibrated pyrometer, probe the #5 patty (front left corner) in the center of the patty.
	<b>Step 4:</b> Using a store calibrated pyrometer, probe the #8 patty (left rear corner) in the center of the patty.

<b>4:1 Patties - Remove in 3 stacks of 2; Probe in center of corner patties (1, 2, 5, 6).</b>	
	<b>Step 1:</b> Using a store calibrated pyrometer, probe the #1 patty (front right corner) in the center of the patty.
	<b>Step 2:</b> Using a store calibrated pyrometer, probe the #2 patty (rear right corner) in the center of the patty.
	<b>Step 3:</b> Using a store calibrated pyrometer, probe the #5 patty (front left corner) in the center of the patty.
	<b>Step 4:</b> Using a store calibrated pyrometer, probe the #6 patty (left rear corner) in the center of the patty.



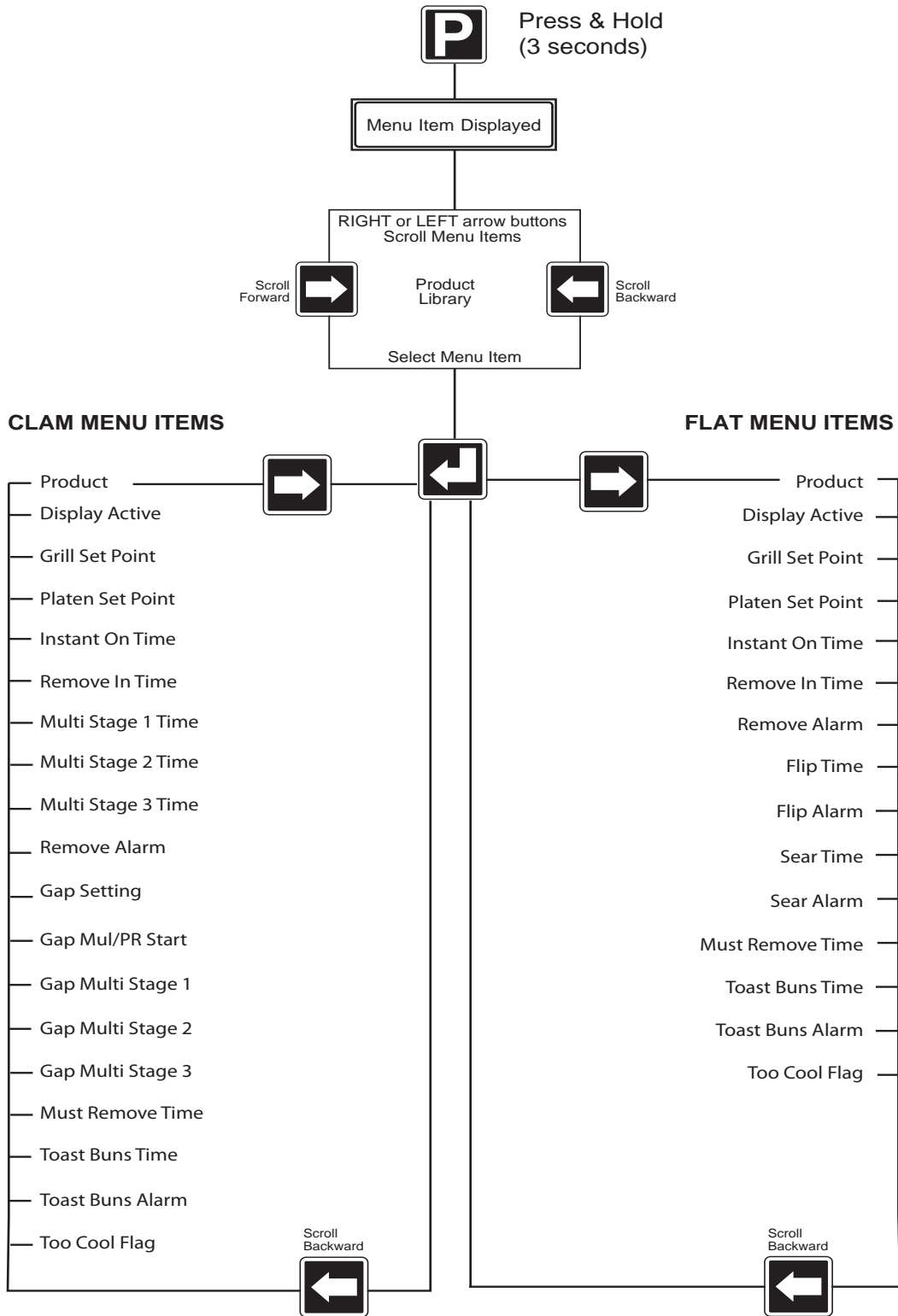



# PROGRAM LOGIC TREE; PRODUCT MENU



## CONTROL PROGRAMMING; PRODUCT MENU





### Programming Modes; Product Menu

#### To change the name of an existing menu item

- Using the  or  button, select the menu item that requires a name change.
- PRESS and HOLD the  button for approximately 3 seconds. Controller will display previously selected menu item and its corresponding item number.
- PRESS and HOLD the  button.
- To spell out the product name:
  - Use the  or  arrow buttons to scroll through the character library.











Character Library:

space ! " # \$ % & ' ( ) \* + , - . / 0 1 2 3 4 5 6 7 8 9 : ; < = > ? @ A B C D E F G H I J K L M N O P Q R S T U V W X Y Z [ \ ] ^ \_ ` a b c d e f g h i j k l m n o p q r s t u v w x y z

- PRESS  or  to scroll right or left.
  - PRESS the  button to save the new menu item name.
- PRESS the  2X to exit and return to normal operating mode.











#### To activate / deactivate a menu item in the Normal Operating mode library, or change its day-part

(Defaults are listed in section "OPERATING PROCEDURES")

- PRESS and HOLD the  button for approximately 3 seconds. Controller will display previously selected menu item and its corresponding item number.
- Using the  or  arrow buttons, select the menu item that requires activation / deactivation.
- PRESS the  button. The controller will display "Product". The menu item will flash.
- PRESS the  or  arrow buttons until "Display Active" is displayed on the controller.
- PRESS the  button. The current setting will flash.
- PRESS the  or  button to select a different setting.
- PRESS the  button to save the new setting.
- PRESS the  2X to exit and return to normal operating mode.







#### To change the grill surface set point temperature

NOTE: Grill temperature set points are preset in the controller to the currently region required standard. Before any adjustment to the grill set point temperature consult McDonald's management office on your region. Garland grill set point temperature default on (More details page 55)





- Using the  or  arrow buttons, select the menu item that requires a temperature change.
- PRESS and HOLD the  button for approximately 3 seconds. Controller will display previously selected menu item and its corresponding item number.
- PRESS the  button. The controller will display "Product".
- PRESS the  or  arrow buttons until "Grill SetPt" is displayed on the controller.
- PRESS the  button. The current grill set temperature will begin to flash.
- Using the  or  button, change the temperature set point to the new desired temperature.
- PRESS the  button to save the new temperature set point.
- PRESS the  2X to exit and return to normal operating mode.

#### To change the grill upper platen set point temperature











NOTE: Grill temperature set points are preset in the controller to the currently required standard. You should not change this set point to any temperature other than what is shown in section "OPERATING PROCEDURES".

- Using the  or  button, select the menu item that requires a temperature change.
- PRESS and HOLD the  button for approximately 3 seconds. Controller will display previously selected menu item and its corresponding item number.
- PRESS the  button. The controller will display "Product".
- PRESS the  or  button until "Platen SetPt" is displayed on the controller.
- PRESS the  button. The "PLATEN SET POINT" will begin to flash.











## CONTROL PROGRAMMING; PRODUCT MENU

6. Using the  or  button, change the temperature set point to the new desired temperature.
7. PRESS the  button to save the new temperature.
8. PRESS the  2X to return to normal operating mode.











### To Change the INSTANT ON TIME

1. Using the  or  button, select the menu item that requires a cook time change.
2. PRESS and HOLD the  button for approximately 3 seconds. Controller will display previously selected menu item and its corresponding item number.
3. PRESS the  button. The controller will display "Product".
4. PRESS the  or  button until "INSTANT ON TIME" is displayed on the controller.
5. PRESS the  button. The seconds will begin to flash.
6. Using the  or  arrow buttons to change the INSTANT ON TIME to the new desired time.
7. PRESS the  button to save the new time.
8. PRESS the  2X to return to normal operating mode.











### To Change the REMOVE IN TIME

1. Using the  or  button, select the menu item that requires a cook time change.
2. PRESS and HOLD the  button for approximately 3 seconds. Controller will display previously selected menu item and its corresponding item number.
3. PRESS the  button. The controller will display "Product".
4. PRESS the  or  button until "REMOVE IN TIME" is displayed on the controller.
5. PRESS the  button. The seconds will begin to flash.
6. Using the  or  arrow buttons to change the REMOVE IN TIME to the new desired time.
7. PRESS the  button to save the new time.
8. PRESS the  2X to return to normal operating mode.





### To Change the MULTI STAGE TIME

1. Using the  or  button, select the menu item that requires a cook time change.
2. PRESS and HOLD the  button for approximately 3 seconds. Controller will display previously selected menu item and its corresponding item number.
3. PRESS the  button. The controller will display "Product".
4. PRESS the  or  button until "MULT STAGE(1,2 or3) TIME" is displayed on the controller.
5. PRESS the  button. The seconds will begin to flash.
6. Using the  or  arrow buttons to change the MULT STAGE TIME to the new desired time.
7. PRESS the  button to save the new time.
8. PRESS the  2X to return to normal operating mode.







### To Change the REMOVE ALARM

1. Using the  or  button, select the menu item that requires a cook time change.
2. PRESS and HOLD the  button for approximately 3 seconds. Controller will display previously selected menu item and its corresponding item number.
3. PRESS the  button. The controller will display "Product".
4. PRESS the  or  button until "REMOVE ALARM" is displayed on the controller.
5. PRESS the  button. The seconds will begin to flash.
6. Using the  or  arrow buttons to change the REMOVE ALARM to the new desired option.
7. PRESS the  button to save the new time.
8. PRESS the  2X to return to normal operating mode.











### To Change the GAP SETTING

1. Using the  or  button, select the menu item that requires a cook time change.
2. PRESS and HOLD the  button for approximately 3 seconds. Controller will display previously selected menu item and its corresponding item number.
3. PRESS the  button. The controller will display "Product".











## CONTROL PROGRAMMING; PRODUCT MENU

4. PRESS the  or  button until "GAP SETTING" is displayed on the controller.
5. PRESS the  button. The seconds will begin to flash.
6. Using the  or  arrow buttons to change the GAP SETTING to the new desired setting.
7. PRESS the  button to save the new time.
8. PRESS the  2X to return to normal operating mode.











### To Change the GAP MUL/PR START

1. Using the  or  button, select the menu item that requires a cook time change.
2. PRESS and HOLD the  button for approximately 3 seconds. Controller will display previously selected menu item and its corresponding item number.
3. PRESS the  button. The controller will display "Product".
4. PRESS the  or  button until "GAP MUL/PR START" is displayed on the controller.
5. PRESS the  button. The seconds will begin to flash.
6. Using the  or  arrow buttons to change the GAP MUL/START to the new desired setting.
7. PRESS the  button to save the new time.
8. PRESS the  2X to return to normal operating mode.











### To Change the GAP MULTI STAGE (1,2 or3)

1. Using the  or  button, select the menu item that requires a cook time change.
2. PRESS and HOLD the  button for approximately 3 seconds. Controller will display previously selected menu item and its corresponding item number.
3. PRESS the  button. The controller will display "Product".
4. PRESS the  or  button until "GAP MULTI STAGE (1,2 or 3)" is displayed on the controller.
5. PRESS the  button. The seconds will begin to flash.
6. Using the  or  arrow buttons to change the GAP MULTI STAGE to the new desired setting.
7. PRESS the  button to save the new time.
8. PRESS the  2X to return to normal operating mode.



### To Change the MUST REMOVE IN

1. Using the  or  button, select the menu item that requires a cook time change.
2. PRESS and HOLD the  button for approximately 3 seconds. Controller will display previously selected menu item and its corresponding item number.
3. PRESS the  button. The controller will display "Product".
4. PRESS the  or  button until "MUST REMOVE IN" is displayed on the controller.
5. PRESS the  button. The seconds will begin to flash.
6. Using the  or  arrow buttons to change the MUST REMOVE IN to the new desired setting.
7. PRESS the  button to save the new time.
8. PRESS the  2X to return to normal operating mode.









### To Change the TOAST BUNS TIME

1. Using the  or  button, select the menu item that requires a cook time change.
2. PRESS and HOLD the  button for approximately 3 seconds. Controller will display previously selected menu item and its corresponding item number.
3. PRESS the  button. The controller will display "Product".
4. PRESS the  or  button until "TOAST BUNS TIME" is displayed on the controller.
5. PRESS the  button. The seconds will begin to flash.
6. Using the  or  arrow buttons to change the TOAST BUNS TIME to the new desired setting.
7. PRESS the  button to save the new time.
8. PRESS the  2X to return to normal operating mode.











### To Change the TOAST BUNS ALARM (Auto / Manual)

1. Using the  or  button, select the menu item that requires a cook time change.
2. PRESS and HOLD the  button for approximately 3 seconds. Controller will display previously selected menu item and its corresponding item number.







## CONTROL PROGRAMMING; PRODUCT MENU





- PRESS the  button. The controller will display "Product".
- PRESS the  or  button until "TOAST BUNS ALARM" is displayed on the controller.
- PRESS the  button. The seconds will begin to flash.
- Using the  or  arrow buttons to change the TOAST BUNS ALARM to the new desired setting.
- PRESS the  button to save the new time.
- PRESS the  2X to return to normal operating mode.

### To Change the TOO COOL FLAG











- Using the  or  button, select the menu item that requires a cook time change.
- PRESS and HOLD the  button for approximately 3 seconds. Controller will display previously selected menu item and its corresponding item number.
- PRESS the  button. The controller will display "Product".
- PRESS the  or  button until "TOO COOL FLAG" is displayed on the controller.
- PRESS the  button. The seconds will begin to flash.
- Using the  or  button, change the TOO COOL FLAG to the new desired setting.
- PRESS the  button to save the new time.
- PRESS the  2X to exit and return to normal operating mode.

### To Change the FLIP TIME











- Using the  or  arrow buttons, select the menu item that requires a cook time change.
- PRESS and HOLD the  button for approximately 3 seconds. Controller will display previously selected menu item and its corresponding item number.
- PRESS the  button. The controller will display "Product".
- PRESS the  or  button until "FLIP TIME" is displayed on the controller.
- PRESS the  button. The current setting will begin to flash.

- Using the  or  arrow buttons to change the FLIP TIME to the new desired setting.
- PRESS the  button to save the new setting.
- PRESS the  2X to exit and return to normal operating mode.

### To Change the FLIP ALARM

- Using the  or  arrow buttons, select the menu item that requires a cook time change.
- PRESS and HOLD the  button for approximately 3 seconds. Controller will display previously selected menu item and its corresponding item number.
- PRESS the  button. The controller will display "Product".
- PRESS the  or  button until "FLIP ALARM" is displayed on the controller.
- PRESS the  button. The current setting will begin to flash.
- Using the  or  arrow buttons to change the FLIP ALARM to the new desired setting.
- PRESS the  button to save the new setting.
- PRESS the  2X to exit and return to normal operating mode.

### To Change the SEAR TIME

- Using the  or  arrow buttons, select the menu item that requires a cook time change.
- PRESS and HOLD the  button for approximately 3 seconds. Controller will display previously selected menu item and its corresponding item number.
- PRESS the  button. The controller will display "Product".
- PRESS the  or  button until "SEAR TIME" is displayed on the controller.
- PRESS the  button. The current setting will begin to flash.
- Using the  or  arrow buttons to change the SEAR TIME to the new desired setting.
- PRESS the  button to save the new setting.

## CONTROL PROGRAMMING; PRODUCT MENU

8. PRESS the **P** 2X to exit and return to normal operating mode.

### To Change the SEAR ALARM

1. Using the **←** or **→** arrow buttons, select the menu item that requires a cook time change.
2. PRESS and HOLD the **P** button for approximately 3 seconds. Controller will display previously selected menu item and its corresponding item number.
3. PRESS the **↵** button. The controller will display "Product".
4. PRESS the **←** or **→** button until "SEAR ALARM" is displayed on the controller.
5. PRESS the **↵** button. The current setting will begin to flash.
6. Using the **↑** or **↓** arrow buttons to change the SEAR ALARM to the new desired setting.
7. PRESS the **↵** button to save the new setting.
8. PRESS the **P** 2X to exit and return to normal operating mode.

### To Add NEW Menu Items

The following programming instructions serves as a GUIDE for programming the basic settings for CLAM menu items.

1. PRESS and HOLD the **P** button for approximately 3 seconds. Controller will display previously selected menu item and its corresponding item number.
2. PRESS the **←** or **→** button until "Opt menu # - CLAM" is displayed on the controller.
3. PRESS the **↵** button. The controller will display "PRODUCT"
4. PRESS and HOLD the **↵** button. The currently select menu item name will begin to flash.
5. To spell out the product name:
  - a. Use the **↑** or **↓** arrow buttons to scroll through the character library.
  - b. PRESS **→** or **←** to scroll right or left.
  - c. PRESS the **↵** button to save the new menu item name.
6. PRESS the **↵** button. "Display Active" will be displayed.
7. PRESS the **↵** button. "NO" will begin to flash.

8. PRESS the **↑** button. "NO" will change to "YES".

9. PRESS the **↵** button to save the new setting.

10. PRESS the **↵** button. "GRILL SETPT" will be displayed.

11. PRESS the **↵** button. The temperature will begin to flash.

12. Using the **↑** or **↓** button, change the temperature set point to the new desired temperature.

13. PRESS the **↵** button to save the new temperature set point.

14. PRESS the **↵** button. "PLATSETPT" will be displayed.

15. PRESS the **↵** button. The temperature will begin to flash.

16. Using the **↑** or **↓** button, change the temperature set point to the new desired temperature.

17. PRESS the **↵** button to save the new temperature set point.

18. PRESS the **↵** button until "GAP MULTI/PR START" appears in the display.

19. PRESS the **↵** button. The gap setting will begin to flash.

20. Using the **↑** and DOWN button, change the gap setting to the desired setting.

21. PRESS the **↵** button to save the new gap setting.

22. PRESS the **P** button 2X to exit and return to the normal operating mode.

### To activate Clean Mode

1. Using the **←** or **→** arrow buttons, select clean mode.
2. Wait until unit cool down to righth temperature. Grill will start beep indicating right temperature to proceed with the cleaning.
3. Wait until unit cool down to righth temperature. proceed with the cleaning.
4. Press the **●** GREEN and proceed to follow cleaning procedures on page 53

# PROGRAM LOGIC TREE; SYSTEM MENU

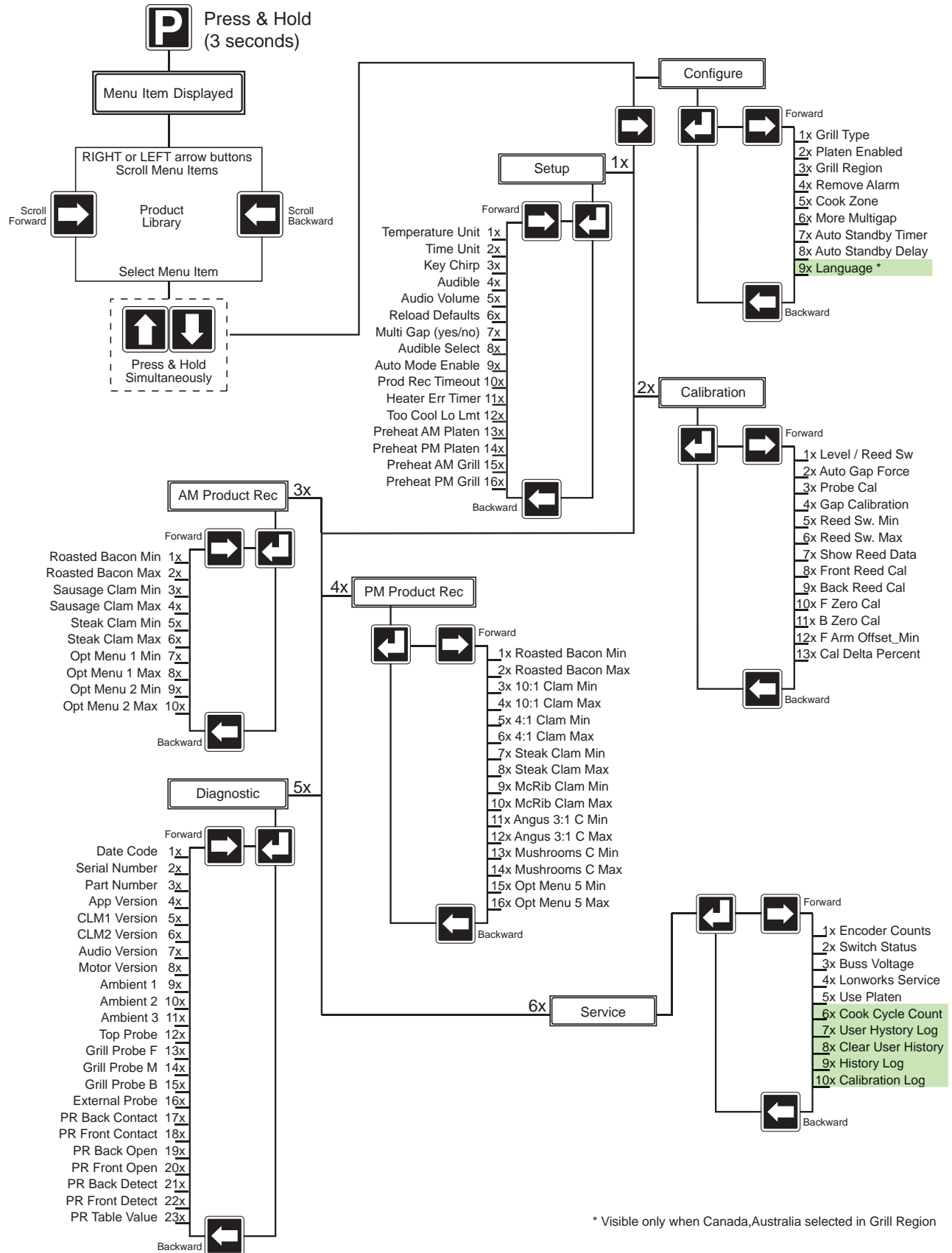

## PROGRAM LOGIC; CONFIGURATION & CALIBRATION SUBMENU

CONFIGURATION SUBMENU	Prompt	Description	Options:	Values	Visibility
	GRILL TYPE	Grill Type	Options: Default:	GAS or ELECTRIC ELECTRIC	Always visible
	PLATEN ENABLED	Allow User to Use on Zone for Flat Product	Options: Default:	YES or NO YES	Always visible
	GRILL REGION	Determines The World Grill location to be Used	Options: Default:	WORLD, JAPAN, HONG KONG, UNITED KINGDOM, AUSTRALIA/CANADA WORLD	Always visible
	REMOVE ALARM	Determine the must remove in alarm type to be used	Options: Default:	TIME THEN ALARM TIME THEN ALARM	Always visible
	COOK ZONE	Defines control panel location on Unit	Options: Default:	CENTER, RIGHT, LEFT LEFT	Always visible
	MORE MULTIGAP	Determines if the multi gap/time menu item prompts are displayed	Options: Default:	YES or NO YES	Always visible
	AUTO STANDBY TMR	Enable/Disable the auto standby feature	Options: Default:	ON or OFF OFF	Always visible
	AUTO STANDBY DLY	The delay time of no key activity before the auto standby warning activates	Options: Default:	1 to 5 3	Always visible - Displayed as minutes.
	LANGUAGE	Language selection	Options: Default:	English or French English	Visible only if Canada/Australia is selected in Grill Region.

CALIBRATION SUBMENU	Prompt	Description	Options:	Values	Visibility
	TEMPERATURE UNIT	Temperature Units	Options: Default:	°C or °F °F	Always visible
	TIME UNIT	Time Units	Options: Default:	MSS (minutes, second) MMM (minutes only) SSS (seconds only) SSS	Always visible
	KEY CHIRP	Key Chirp (beep sound)	Options: Default:	Yes or No Yes	Always visible
	AUDIBLE	Audible Alarm Sound	Options: Default:	Off, 3 Second, Stroke, Song 3 Sec	Always visible
	AUDIO VOLUME	Audio Volume	Options: Default:	from 0 to 100 (low to high) 100	Always visible
	RELOAD DEFAULTS	Reload McDonald's Menu structure	Options: Default:	Yes or No No	Always visible
	MULTI GAP	Allows for Multi Gapping of the Platen	Options: Default:	Yes or No Yes	Only visible if platen enabled
	AUDIBLE SELECT	Allow User to Select Desired Loudness of Audible	Options: Default:	0, 1 or 2 1	Always visible
	AUTO MODE ENABLE	Allow User to User	Options: Default:	Yes or No Yes	Only visible if platen enabled
	PROD REC TIMEOUT	Allows user to select desired time where PR will be aborted	Options: Default:	1 to 30 10	Always visible
	HEATER ERR TIMER	The period of time used to determine HEATER ERR	Range: Default:	60 to 1200 425	Always visible
	TOO COOL LO LMT	The offset to the minimum safety limit that would alarm and prevent the starting of a cook cycle if the TOO COOL FLAG is activated	Range: Default:	OFF, 1F to 450F OFF	Always visible
	PR AM PLATEN SP	Temperature set point at the platen when is PR Mode - AM Menu	Range: Default:	Off - 450F 425F	Always visible
	PR PM PLATEN SP	Temperature set point at the platen when is PR Mode - PM Menu	Range: Default:	Off - 450F 425F	Always visible
	PR AM GRILL SP	Temperature set point at the grill when is PR Mode - AM Menu	Range: Default:	Off - 450F 350F	Always visible
	PR PM GRILL SP	Temperature set point at the grill when is PR Mode - PM Menu	Range: Default:	Off - 450F 350F	Always visible
	PREHEAT AM PLATEN	PreHeat of platen for AM Menu	Range: Default:	250 - 450F 425F	Always visible
	PREHEAT PM PLATEN	PreHeat of platen for PM Menu	Range: Default:	250 - 450F 425F	Always visible
	PREHEAT AM GRILL	PreHeat of grill for AM Menu	Range: Default:	250 - 450F 275F	Always visible
	PREHEAT PM GRILL	PreHeat of grill for PM Menu	Range: Default:	250 - 450F 350F	Always visible

## PROGRAM LOGIC; CALIBRATION SUBMENU

	Prompt	Description	Values	Visibility
	<b>CALIBRATION SUBMENU</b>	LEVEL/REED SW	Allow technician to adjust platen reed switches	Options: YES or NO Default: NO
AUTO GAP FORCE		Allow User to run an calibration manually	Options: YES or NO Default: NO	Only visible if platen is enabled
PROBE CAL		Offset for temp calibration	Options: Default:	Top only visible if platen is enabled
GAP CALIBRATION			Range: -20 to +20 Default: 0	Only visible if platen is enabled
REED SW MIN		Allow User to select the min. limit for gap cal.	Range: 0 to 1000 Default: 200	Only visible if platen is enabled
REED SW MAX		Allow User to select the max. limit for gap cal. A delta > than this creates a platen error.	Range: 0 to 1000 Default: 300	Only visible if platen is enabled
SHOW REED DATA		Switch used to determine if reed cal data is displayed.	Options: YES or NO Default: NO	Only visible if platen is enabled
FL REED CAL CLS		Close reading of the <i>Front Left</i> Reed switch during calibration	Options: N/A Default: 999	Only visible if platen is enabled
RL REED CAL CLS		Close reading of the <i>Rear Left</i> Reed switch during calibration	Options: N/A Default: 999	Only visible if platen is enabled
FR REED CAL CLS		Close reading of the <i>Front Right</i> Reed switch during calibration	Options: N/A Default: 999	Only visible if platen is enabled
RR REED CAL CLS		Close reading of the <i>Rear Right</i> Reed switch during calibration	Options: N/A Default: 999	Only visible if platen is enabled
FL REED CAL OPEN		Open reading of the <i>Front Left</i> Reed switch during calibration	Options: N/A Default: 999	Only visible if platen is enabled
RL REED CAL OPEN		Open reading of the <i>Right Left</i> Reed switch during calibration	Options: N/A Default: 999	Only visible if platen is enabled
FR REED CAL OPEN		Open reading of the <i>Front Right</i> Reed switch during calibration	Options: N/A Default: 999	Only visible if platen is enabled
RR REED CAL OPEN		Open reading of the <i>Rear Right</i> Reed switch during calibration	Options: N/A Default: 999	Only visible if platen is enabled
F ARM OFFSET MIN		Minimum offset value to be subtracted from front reed switch value	Range: -3000 to 1000 Default: 20	TBA
FRONT CORRECTION		Value use by the PR algorithm	Range: 0 - 1 Default: 0.83	TBA
CAL DELTA PERCNT		% of reed switch delta to be subtracted from front reed switch value.	Range: 0 to 100 Default: 99	TBA
PR LEVEL PERCNT		Correction value use by the PR algorithm	Range: 1 - 99 Default: 99	TBA
CRC		Correction value use by the PR algorithm	Range: 0 - 201 Default: 100	TBA

## PROGRAM LOGIC; CALIBRATION SUBMENU

CALIBRATION SUBMENU	Prompt	Description	Visibility
	DATECODE	Date of manufacture (week /year)	Read Only
	SERIAL NUMBER	Serial Number	Read Only
	PART NUMBER	Control model number	Read Only
	APP VERSION	Application number and revision	Read Only
	CLM 1 VERSION	Control loop module 1 number and revision	Read Only
	CLM 2 VERSION	Control loop module 2 number and revision	Read Only
	AUDIO VERSION	Audio module number and revision	Read Only
	MOTOR VERSION	Motor control number and revision	Read Only
	AMBIENT 1	Cjc 1 temperature	Read Only
	AMBIENT 2	Cjc 2 temperature	Read Only
	AMBIENT 3	Cjc 3 temperature	Read Only
	TOP PROBE	Platen Temperature	Visible if the platen is enabled - Read Only
	GRILL PROBE F	Grill front temperature	Read Only
	GRILL PROBE M	Grill middle temperature	Read Only
	GRILL PROBE B	Grill back temperature	Read Only
	EXTERNAL PROBE	Actual temperature channel	Read Only
	FL REED PR CLS	Front Left reed switch close mils during PR. Raw values	Read Only
	RL REED PR CLS	Rear Left reed switch close mils during PR. Raw values	Read Only
	FR REED PR CLS	Front Right reed switch close mils during PR. Raw values	Read Only
RR REED PR CLS	Rear Right reed switch close mils during PR. Raw values	Read Only	
FL REED PR OPEN	Front Left reed switch open mils during PR. Raw values	Read Only	
RL REED PR OPEN	Rear Left reed switch open mils during PR. Raw values	Read Only	
FR REED PR OPEN	Front Right reed switch open mils during PR. Raw values	Read Only	
RR REED PR OPEN	Rear Right reed switch open mils during PR. Raw values	Read Only	
FL PR CONTACT	Front Left reed switch close mils during PR. Calculated values	Read Only	
RL PR CONTACT	Rear Left reed switch close mils during PR. Calculated values	Read Only	
FR PR CONTACT	Front Right reed switch close mils during PR. Calculated values	Read Only	
RR PR CONTACT	Rear Right reed switch close mils during PR. Calculated values	Read Only	
PR TABLE VALUE	Last product recognition mils	Read Only	

SERVICE SUBMENU	Prompt	Description	Values	Visibility
	ENCODER COUNTS	Encoder counts	Options: Default:	Always visible - Displayed as decimal value.
	SWITCH STATUS	Status for switches	Options: Default: 8	Always visible - Displayed as decimal value.
	BUSS VOLTAGE	Buss voltage value	Range: 120 - 350 Default: "Value" (see NOTE below)	Always visible.
	LONWORKS SERVICE	Used to indicate LonWorks activity	Options: YES to NO Default: NO	Always visible.
	USE PLATEN	Enable or disable platen	Options: YES or NO Default: YES	Always visible.
	COOK CYCLE COUNT	Cook cycle count	Options: 0 - 9999999 Default: N/A	Always visible.
	USER HIST. LOG	(More details page 44)	Range: 0 to 99 Default: N/A	Always visible.
	CLEAR USER HIST.	Clear User history log	Options: YES or NO Default: NO	Always visible.
	HISTORY LOG.	User history log	Range: 0 to 99 Default: 0	Always visible.
CALIBRATION LOG.	Reading from last calibration (See error log for details)	Range: Last calibration saved Default: 0	Always visible.	

## CONTROL PROGRAMMING; SYSTEM MENU

### Programming Modes; System Setup

#### To Change the Temperature Display Units (Fahrenheit / Celcius)

The temperature display units (F or C) will change the way a temperature is displayed on the controller (F – Fahrenheit, C – Celcius)

1. With the controller display ON and either displaying the current menu item or displaying "OFF", PRESS and HOLD the **P** button for approximately 3 seconds. Controller will display previously selected menu item and its corresponding item number OR "Standby / Menu Item".
2. PRESS the **↑** AND **↓** arrow buttons TOGETHER. "CONFIGURE" will appear in the display.
3. PRESS the **→** arrow button. "Setup" will appear in the display
4. PRESS the **↩** button. "Temperature Unit" will appear in the display.
5. PRESS the **↩** button. The currently set temperature unit will flash.
6. PRESS the **↑** OR **↓** arrow buttons to change the flashing temperature unit.
7. PRESS the **↩** button to save the new setting.
8. PRESS THE **P** 2X to exit the program mode.

#### To Change the Time Display Units

Changing the Time Display Units will change the way timing cycles are displayed on the controller.

1. With the controller display ON and either displaying the current menu item or displaying "OFF", PRESS and HOLD the **P** button for approximately 3 seconds. Controller will display previously selected menu item and its corresponding item number OR "Standby / Menu Item".
2. PRESS the **↑** AND **↓** arrow buttons TOGETHER. "CONFIGURE" will appear in the display.
3. PRESS the **→** arrow button. "Setup" will appear in the display.
4. PRESS the **↩** button. "Temperature Unit" will appear in the display.
5. PRESS the **↩** 1X. "Time Unit" will appear in the display.

6. PRESS the **↩** button. The current time unit will flash.
7. PRESS the **↑** OR **↓** arrow buttons to change the flashing time unit.  
**For a complete listing of setup functions and their options, see section titled "FUNCTION OPTIONS; SYSTEM MENUS".**
8. PRESS the **↩** button to save the new setting
9. PRESS THE **P** 2X to exit the program mode.

#### To change the Key Chirp (Yes / No)











Changing the Key Chirp On or Off will either turn on or off the sound of the controller when a button is pressed.

1. With the controller display ON and either displaying the current menu item or displaying "OFF", PRESS and HOLD the **P** button for approximately 3 seconds. Controller will display previously selected menu item and its corresponding item number OR "Standby / Menu Item".
2. PRESS the **↑** AND **↓** arrow buttons TOGETHER. "CONFIGURE" will appear in the display.
3. PRESS the **→** arrow button. "Setup" will appear in the display
4. PRESS the **↩** button. "Temperature Unit" will appear in the display.
5. PRESS the **→** repeatedly until "Key Chirp" appears in the display.
6. PRESS the **↩** button. The currently set Key Chirp will flash.
7. PRESS the **↑** OR **↓** arrow buttons to change the flashing "YES" or "NO"
8. PRESS the **↩** button to save the new setting.
9. PRESS THE **P** 2X to exit the program mode.

## CONTROL PROGRAMMING; SYSTEM MENU

### To change the Audible

Changing the Audible Sound will change the way the controller sounds when a timing cycle has completed its countdown.



1. With the controller display ON and either displaying the current menu item or displaying "OFF", PRESS and HOLD the  button for approximately 3 seconds. Controller will display previously selected menu item and its corresponding item number OR "Standby / Menu Item".
2. PRESS the  AND  arrow buttons TOGETHER. "CONFIGURE" will appear in the display.
3. PRESS the  arrow button. "Setup" will appear in the display
4. PRESS the  button. "Temperature Unit" will appear in the display.
5. PRESS the  repeatedly until "Audible" appears in the display.
6. PRESS the  button. The currently set Audible will flash.
7. PRESS the  OR  arrow buttons to change the flashing audible options.  
**For a complete listing of setup functions and their options, see section titled "FUNCTION OPTIONS; SYSTEM MENUS".**
8. PRESS the  button to save the current setting.
9. PRESS THE  2X to exit the program mode.









**WARNING,**







The following procedure will result in replacing all actual setting on the grill (temperatures, cooking time and others), being reset to their factory setting defaults.

### To Restore Factory Defaults for All Product Menu Items

1. With the controller display ON and either displaying the current menu item or displaying "OFF," PRESS and HOLD the  button for approximately 3 seconds. Controller will display previously selected menu item and its corresponding item number OR "Standby / Menu Item."
2. PRESS the  AND  arrow buttons TOGETHER. "CONFIGURE" will appear in the display.

3. PRESS the  arrow button. "Setup" will appear in the display
4. PRESS the  button. "Temperature Unit" will appear in the display.
5. PRESS the  button 6x. The controller will display "Reload Defaults – NO."
6. PRESS the  button. "NO" will begin to flash.
7. PRESS the  button. "NO" will change to "YES".
8. PRESS the  button. The system will Reload the MENU items to factory default settings.
9. Wait 15-20 seconds. The control then automatically returns to OFF mode.

### To Restore Factory Defaults for All Functions

1. Ensure the main power is turned off by turning the main power switch to the OFF mode.
2. PRESS the  AND  arrow buttons TOGETHER, while cycling main power ON with the main power switch. The control will display "PASSWORD"
3. Within 3-5 seconds, press the following keys in this sequence:     
4. Upon successful completion, the controller will display FULL DEFAULTS
5. Wait 15-20 seconds. The control then automatically returns to OFF mode.

# FACTORY DEFAULT SETTING

## Factory Default Setting - Product Menu - World

Menu #	PRODUCT	DIS-PLAY ACTIVE	GRILL SETPT.	PLATEN SP.	IN-STANT ON TIME (GAS)	RE-MOVE IN TIME	MULT STAGE 1 TIME	MULT STAGE 2 TIME	MULT STAGE 3 TIME	RE-MOVE ALARM	GAP SETTING	GAP MUL/PR START	GAP MULTI STAGE 1	GAP MULTI STAGE 2	GAP MULTI STAGE 3	FUP TIME	FLIP ALARM	SEAR TIME	SEAR ALARM	MUST RE-MOVE IN	TOAST BUNS TIME	TOAST BUNS ALARM	TOO COOL FLAG	Hidden Value	
																								"PR Min"	"PR Max"
1	Off 10:1 CLAM (HIPD)	PM	350°F	425°F	25 (5)	37	5	0	0	AUTO	255	245	265	0	0	0	N/A	N/A	N/A	0	AUTO	NO	160	345	
2	4:1 CLAM (HIPD)	PM	350°F	425°F	30 (10)	107	10	0	0	AUTO	415	400	425	0	0	0	N/A	N/A	N/A	0	AUTO	NO	365	499	
3	ROAST BACON CLAM (HIPD)	AM/PM	350°F	425°F	0	70 (60)	0	0	0	AUTO	265	265	0	0	0	N/A	N/A	N/A	N/A	0	NONE	NONE	NO	1	130
4	SAUSAGE CLAM FZN (HIPD)	AM	350°F	425°F	0	82	0	0	0	AUTO	350	350	0	0	0	N/A	N/A	N/A	N/A	0	NONE	NONE	NO	210	405
5	MCRIB CLAM (HIPD)	NO	350°F	425°F	30 (10)	163	0	0	0	AUTO	530	530	0	0	0	N/A	N/A	N/A	N/A	0	NONE	NONE	NO	N/A	N/A
6	STEAK CLAM (HIPD)	AM	350°F	425°F	0	104	0	0	0	AUTO	415	415	0	0	0	N/A	N/A	N/A	N/A	0	NONE	NONE	YES	430	480
7	GRILL CHICK. FLAT	PM	350°F	425°F	45	475	N/A	N/A	N/A	AUTO	N/A	N/A	N/A	N/A	N/A	225	MANU-AL	0	NONE	0	NONE	NONE	YES		
8	FOLDED EGGS FLAT	AM	265°F	OFF	0	120	N/A	N/A	N/A	AUTO	N/A	N/A	N/A	N/A	N/A	0	NONE	0	NONE	0	NONE	NONE	YES		
9	ROUND EGGS FLAT	AM	265°F	OFF	0	150	N/A	N/A	N/A	AUTO	N/A	N/A	N/A	N/A	N/A	0	NONE	0	NONE	0	NONE	NONE	NO		
10	CHIC F BRD FLAT	NO	350°F	425°F	0	100	N/A	N/A	N/A	AUTO	N/A	N/A	N/A	N/A	N/A	0	NONE	0	NONE	0	NONE	NONE	NO		
11	10:1 FLAT	NO	340°F	425°F	0	125	N/A	N/A	N/A	AUTO	N/A	N/A	N/A	N/A	N/A	75	AUTO	20	MANU-AL	0	NONE	NONE	NO		
12	4:1 FLAT	NO	365°F	425°F	0	270	N/A	N/A	N/A	AUTO	N/A	N/A	N/A	N/A	N/A	150	AUTO	20	MANU-AL	0	NONE	NONE	NO		
13	MCRIB FLAT	NO	365°F	425°F	0	390	N/A	N/A	N/A	AUTO	N/A	N/A	N/A	N/A	N/A	270	AUTO	0	NONE	0	NONE	NONE	NO		
14	SAUSAGE FLAT FZN	NO	365°F	425°F	0	270	N/A	N/A	N/A	AUTO	N/A	N/A	N/A	N/A	N/A	150	MANU-AL	0	MANU-AL	0	NONE	NONE	NO		
15	HOTCAKES FLAT	NO	365°F	425°F	0	140	N/A	N/A	N/A	AUTO	N/A	N/A	N/A	N/A	N/A	90	AUTO	0	NONE	0	NONE	NONE	NO		
16	OPT. MENU1 CLAM (HIPD)	NO	OFF	OFF	0	0	0	0	0	AUTO	469	469	0	0	0	N/A	N/A	N/A	N/A	0	NONE	NONE	NO		
17	OPT. MENU 2 - CLAM (HIPD)	NO	OFF	OFF	0/0	0	0	0	0	AUTO	250	250	0	0	0	N/A	N/A	N/A	N/A	0	NONE	NONE	NO		
18	ANGUS 3:1 CLAM (HIPD)	PM	350°F	425°F	60 (30)	170	0	0	0	AUTO	534	534	0	0	0	N/A	N/A	N/A	N/A	0	NONE	NONE	NO	500	725
19	MUSHROOMS CLAM (HIPD)	AM/PM	350°F	425°F	60 (45)	104	0	0	0	AUTO	425	425	0	0	0	N/A	N/A	N/A	N/A	0	NONE	NONE	YES		
20	OPT. MENU 5 CLAM (HIPD)	NO	OFF	OFF	0	0	0	0	0	AUTO	250	250	0	0	0	N/A	N/A	N/A	N/A	0	NONE	NONE	NO		
21	OPT. MENU 6 CLAM (HIPD)	NO	OFF	OFF	0	0	0	0	0	AUTO	250	250	0	0	0	N/A	N/A	N/A	N/A	0	NONE	NONE	NO		
22	OPT. MENU 7 - CLAM (HIPD)	NO	OFF	OFF	0	0	0	0	0	AUTO	250	250	0	0	0	N/A	N/A	N/A	N/A	0	AUTO	NO			
23	FOLDED EGGS CLAM (HIPD)	NO	285°F	300°F	0	120	0	0	0	AUTO	625	625	0	0	0	N/A	N/A	N/A	N/A	0	NONE	NONE	NO		
24	ROUND EGGS CLAM (HIPD)	NO	285°F	300°F	0	150	0	0	0	AUTO	625	625	0	0	0	N/A	N/A	N/A	N/A	0	NONE	NONE	NO		
25	OPT. MENU 3 FLAT	NO	OFF	OFF	0	0	N/A	N/A	N/A	AUTO	N/A	N/A	N/A	N/A	N/A	0	AUTO	0	AUTO	0	NONE	NONE	NO		
26	OPT. MENU 4 FLAT	NO	OFF	OFF	0	0	N/A	N/A	N/A	AUTO	N/A	N/A	N/A	N/A	N/A	0	AUTO	0	AUTO	0	NONE	NONE	NO		
	CLEAN MODE (Not shown)	AM & PM	325°F	325°F						MANU-AL															

HIPD: means that this product will not be available to the operator if the platen is disabled

NOTE:

- All parameters can be accessed and edited by pressing the P key then using UP/Down/Right/Left/Enter keys.
- Values for Electric and Gas units are the same unless an extra value is specified in brackets ( ) which corresponds to Gas.
- N/A means that this parameter is not applicable for this product and the menu will skip to the next available parameter.
- When platen is disabled, the Platen Set Point will no longer be visible unless it is normally set to "OFF". While the platen is enabled, in this case, the platen set point will remain "OFF".
- The TOO COOL FLAG setting is not visible on gas grills.
- The PR Values are not visible to the operator.

Conversion Values:  
 265°F = 129°C  
 285°F = 140°C  
 300°F = 149°C  
 350°F = 177°C  
 425°F = 218°C

# FACTORY DEFAULT SETTING

## Factory Default Setting - Product Menu - Canada, Australia & UK

**CANADA PRODUCT MENU SETTING ONLY**

Menu #	PRODUCT	ACTIVE	GRILL SETPT	PLATEN SETPT	INSTANT ON TIME	RE-MOVE IN TIME	MULT STAGE 1 TIME	MULT STAGE 2 TIME	MULT STAGE 3 TIME	RE-MOVE ALARM	GAP SETTING	GAP MUL/PR START	GAP MULTI STAGE 1	GAP MULTI STAGE 2	GAP MULTI STAGE 3	MUST RE-MOVE IN	TOAST BUNS TIME	TOAST BUNS ALARM	TOO COOL FLAG	PR Min	PR Max
	Off		NONE	NONE																	
1	10:1 CLAM (HIPD)	PM	350°F	425°F	25 (5)	37	5	0	0	AUTO	255	245	265	0	0	0	0	AUTO	NO	160	345
2	4:1 CLAM (HIPD)	PM	350°F	425°F	30 (10)	107	10	0	0	AUTO	415	400	425	0	0	0	0	AUTO	NO	365	529
18	3:1 ANGUS - CLAM (HIPD)	PM	350°F	425°F	60 (30)	190	0	0	0	AUTO	574	574	0	0	0	0	NONE	NONE	NO	530	750

**UNITED KINGDOM (UK) PRODUCT MENU SETTINGS ONLY**

Menu #	PRODUCT	ACTIVE	GRILL SETPT	PLATEN SETPT	INSTANT ON TIME (ELEC)	RE-MOVE IN TIME	MULT STAGE 1 TIME	MULT STAGE 2 TIME	MULT STAGE 3 TIME	RE-MOVE ALARM	GAP SETTING	GAP MUL/PR START	GAP MULTI STAGE 1	GAP MULTI STAGE 2	GAP MULTI STAGE 3	MUST RE-MOVE IN	TOAST BUNS TIME	TOAST BUNS ALARM	TOO COOL FLAG	PR Min	PR Max
1	10:1 CLAM (HIPD)	PM	350°F	425°F	30 (10)	47	25	0	0	AUTO	245	240	245	0	0	0	22	AUTO	YES	160	345
2	4:1 CLAM (HIPD)	PM	350°F	425°F	30 (10)	114	10	70	0	AUTO	395	395	425	395	0	15	25	AUTO	YES	365	499

PD: means that this product will not be available to the operator if the platen is disabled

JTE:

All parameters can accessed and edited by pressing the P key then using UP/Down/Right/Left/Enter keys.

Values for Electric and Gas units are the same unless an extra value is specified in brackets ( ) which corresponds to Gas.

N/A means that this parameter is not applicable for this product and the menu will skip to the next available parameter.

When platen is disabled, the Platen Set Point will no longer be visible unless it is normally set to "Off". While the platen is enabled, in this case, the platen set point will remain "Off".

The TOO COOL FLAG setting is not visible on gas grills.

The PR Values are not visible to the operator.

Conversion Values:

265°F = 129°C

285°F = 140°C

300°F = 149°C

350°F = 177°C

425°F = 218°C

# FACTORY DEFAULT SETTING

## Factory Default Setting - Product Menu - Japan & Hong Kong

Menu #	PRODUCT	ACTIVE Edit (Pro-gram)	GRILL SETPT	PLATEN SETPT	INSTANT ON TIME (GAS)	REMOVE IN TIME	MULTI STAGE 1 TIME	MULTI STAGE 2 TIME	MULTI STAGE 3 TIME	REMOVE ALARM	GAP SETTING	GAP MUJ/PR START	GAP MULTI STAGE 1	GAP MULTI STAGE 2	GAP MULTI STAGE 3	FLIP TIME	FLIP ALARM	SEAR TIME	SEAR ALARM	MUST REMOVE IN	TOAST BUNS TIME	TOAST BUNS ALARM
1	Off 10:1 CLAM (HIPD)	PM	177C	218C	25 (5)	37	5	0	0	AUTO	255	245	265	0	0	N/A	N/A	N/A	N/A	18	0	AUTO
2	4:1 CLAM (HIPD)	PM	177C	218C	30 (10)	107	10	0	0	AUTO	415	400	425	0	0	N/A	N/A	N/A	N/A	15	0	NONE
3	SLICE BACON CLAM (HIPD)	NO	177C	218C	0	23	0	0	0	AUTO	89	89	0	0	0	N/A	N/A	N/A	N/A	0	0	NONE
4	SAUSAGE CLAM FZN (HIPD)	AM	177C	218C	0	82	0	0	0	AUTO	343	343	0	0	0	N/A	N/A	N/A	N/A	0	0	NONE
5	MCRIB CLAM (HIPD)	NO	177C	218C	30 (10)	163	0	0	0	AUTO	530	530	0	0	0	N/A	N/A	N/A	N/A	0	0	NONE
6	STEAK CLAM (HIPD)	NO	177C	218C	0	104	0	0	0	AUTO	415	415	0	0	0	N/A	N/A	N/A	N/A	0	0	NONE
7	GRILL CHICKEN FLAT	PM	177C	218C	45	410	N/A	N/A	N/A	AUTO	N/A	N/A	N/A	N/A	N/A	195	MANUAL	0	NONE	0	0	NONE
8	FOLDED EGGS FLAT	AM	129C	OFF	0	120	N/A	N/A	N/A	AUTO	N/A	N/A	N/A	N/A	N/A	0	NONE	0	NONE	0	0	NONE
9	ROUND EGGS FLAT	AM/PM	135C	OFF	0	135	N/A	N/A	N/A	MANUAL	N/A	N/A	N/A	N/A	N/A	0	NONE	0	NONE	0	0	NONE
10	CHIC F BRD FLAT	NO	177C	218C	0	100	N/A	N/A	N/A	AUTO	N/A	N/A	N/A	N/A	N/A	0	NONE	0	NONE	0	0	NONE
11	10:1 FLAT	NO	171C	218C	0	125	N/A	N/A	N/A	AUTO	N/A	N/A	N/A	N/A	N/A	75	AUTO	20	MANUAL	18	0	NONE
12	4:1 FLAT	NO	185C	218C	0	270	N/A	N/A	N/A	AUTO	N/A	N/A	N/A	N/A	N/A	150	AUTO	20	MANUAL	15	0	NONE
13	MCRIB FLAT	NO	185C	218C	0	390	N/A	N/A	N/A	AUTO	N/A	N/A	N/A	N/A	N/A	200	AUTO	0	NONE	0	0	NONE
14	SAUSAGE FLAT FZN	NO	185C	218C	0	270	N/A	N/A	N/A	AUTO	N/A	N/A	N/A	N/A	N/A	150	MANUAL	0	MANUAL	0	0	NONE
15	HOTCAKES FLAT	NO	185C	218C	0	140	N/A	N/A	N/A	AUTO	N/A	N/A	N/A	N/A	N/A	90	AUTO	0	NONE	0	0	NONE
16	OPT. MENU 1 CLAM (HIPD)	NO	OFF	OFF	0	0	0	0	0	AUTO	469	469	0	0	0	N/A	N/A	N/A	N/A	0	0	NONE
17	OPT. MENU 1 CLAM (HIPD)	NO	OFF	OFF	0	0	0	0	0	AUTO	250	250	0	0	0	N/A	N/A	N/A	N/A	0	0	NONE
18	ANGUS 3:1 CLAM (HIPD)	NO	177C	218C	60 (30)	230	0	0	0	AUTO	625	625	0	0	0	N/A	N/A	N/A	N/A	0	0	NONE
19	MUSHROOMS CLAM (HIPD)	NO	177C	218C	60 (45)	104	0	0	0	AUTO	415	415	0	0	0	N/A	N/A	N/A	N/A	0	0	NONE
20	HI TEMP TEST GRIL	AM / PM	177C	218C	0	3599	0	0	0	AUTO	250	250	0	0	0	N/A	N/A	N/A	N/A	0	0	NONE
21	HI TEMP TEST PLT	AM / PM	177C	218	0	3599	0	0	0	AUTO	250	250	0	0	0	N/A	N/A	N/A	N/A	0	0	NONE
22	TERYAKI CLAM (HIPD)	PM	177C	218C	0	80	0	0	0	AUTO	366	366	0	0	0	N/A	N/A	N/A	N/A	0	0	NONE
23	FOLDED EGGS CLAM (HIPD)	NO	140°F	149°F	0	120	0	0	0	AUTO	625	625	N/A	N/A	N/A	0	0	0	AUTO	0	0	NONE
24	ROUND EGGS CLAM (HIPD)	NO	140°F	149°F	0	150	0	0	0	AUTO	625	625	N/A	N/A	N/A	0	0	0	NAUTO	0	0	NONE
25	OPT. MENU 3 FLAT	NO	OFF	OFF	0	0	N/A	N/A	N/A	AUTO	N/A	N/A	N/A	N/A	N/A	0	AUTO	0	AUTO	0	0	NONE
26	TERYAKI FLAT	NO	177C	OFF	0	180	N/A	N/A	N/A	AUTO	N/A	N/A	N/A	N/A	N/A	0	AUTO	0	MANUAL	0	0	NONE
27	"CLEAN MODE (Not visible)"	{AM &PM}	3259F	3259F						MANUAL												

Conversion Values:  
 265° F = 129° C  
 285° F = 140° C  
 300° F = 149° C  
 350° F = 177° C  
 425° F = 218° C

NOTE:  
 • All parameters can be accessed and edited by pressing the P key then using UP/Down/Right/Left/Enter keys.  
 • Values for Electric and Gas units are the same unless an extra value is specified in brackets ( ) which corresponds to Gas.  
 • N/A means that this parameter is not applicable for this product and the menu will skip to the next available parameter.  
 • When platen is disabled, the Platen Set Point will no longer be visible unless it is normally set to "Off". While the platen is disabled, the platen set point will remain "Off".  
 • The TOO COOL FLAG setting is not visible on gas grills.

## PLATEN LEVELING

### 1. Platen Level Check Procedure.





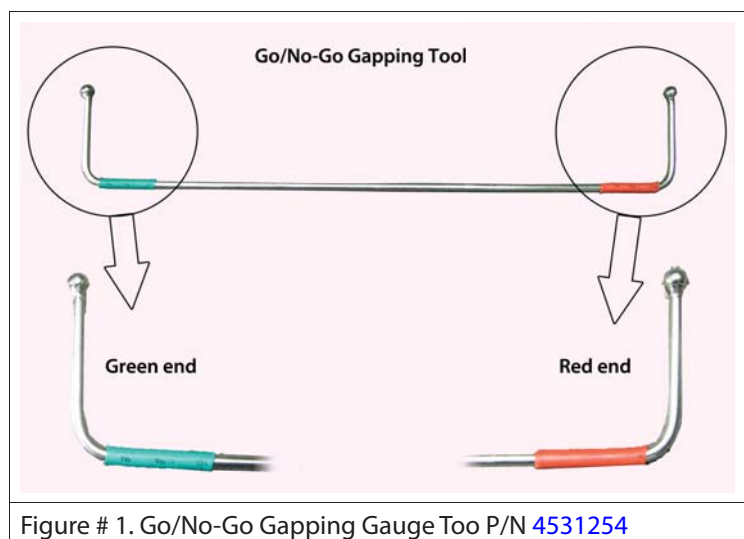



In order to ensure that the platen is level within acceptable limits, you should use the Go/No-Go Gapping Tool check gauge, P/N 4531254, shown fig #1.

- 1-1. Instruction for the use of this gauge can be found at <https://clamshell.garland-group.com>. If this gauge is not available or if the platen needs to be re-levelled, then proceed with step #2.



### 2. Platen Levelling Procedure.

In order to achieve proper cooking performance, you need to ensure that the platen is level to the grill, that the platen reed switches are in their proper location, and that all magnets are the correct distance, away from the switches (located inside the upper platen).

- 2-1. Enter the "LEVEL/REED SW" Mode"
  - a. With the controller display ON and either displaying the current menu item or displaying "OFF", PRESS and HOLD the  button for approximately 3 seconds. Controller will display the previously selected menu item and its corresponding item number OR "Standby / Menu Item".
  - b. PRESS the  AND  arrow buttons TOGETHER for approximately 3 seconds and "CONFIGURE" will appear in the display.
  - c. PRESS the  2X. "CALIBRATION" will appear in the display.
  - d. PRESS the  button. "LEVEL/REED SW" will appear in the display.
  - e. PRESS the  button. "NO" will begin to flash.
  - f. PRESS the  button. "NO" will change to "YES".
  - g. PRESS the  button. "YES" will stop flashing.
  - h. Ensure the grill surface is free of objects and debris, and ensure that Teflon release sheets (if used) are removed and then press the  GREEN push-button to lower the platen.
- 2-2. Using a flat screwdriver or the Platen Adjusting tool, remove the platen adjuster grease caps.
- 2-3. Using a flat screwdriver or the Platen Adjusting tool, remove the platen adjuster locking caps.

## PLATEN LEVELING

### 2-4. Adjust Platen:

- a. Using a flat screwdriver or the Platen Adjusting tool, adjust rear of platen until the GO portion of the Gap Gauge P/N 1838701 (Fig#3) fits snugly between the upper platen and grill surface. The Gap Gauge should fit snugly under the platen, but STOP at the first raised step on the gapping tool (No-Go). See gauge conventions in Figure #4
- b. Move next to the front adjustment and raise or lower the front of the upper platen until the Gap Gauge fits snugly between the upper platen and grill surface. The front of the platen has only a SINGLE-POINT adjustment. Fit the Gap Gauge under the front of the platen, and adjust until both sides gauge equally.
- c. At times, it may be difficult to have the gauge pass correctly on all four corners. In this event, ensure the two front locations are gapped correctly, and then ensure that at least one of the rear locations is gapped correctly leaving the other rear location with a smaller gap such that it fails the GO condition of the gauge. The NO GO portion of the gauge should never fail at any location during platen levelling.

2-5. After the platen is leveled, check to ensure that for each adjuster nut, no more than two (2) threads are exposed or hidden in comparison to the arm, see proper setup of adjuster nuts (see fig# 5, 6 & 7).

2-6. After adjusting the upper platen, YOU MUST ADJUST AND SET THE UPPER PLATEN REED SWITCHES. Refer to next section in the Service Manual for more details.

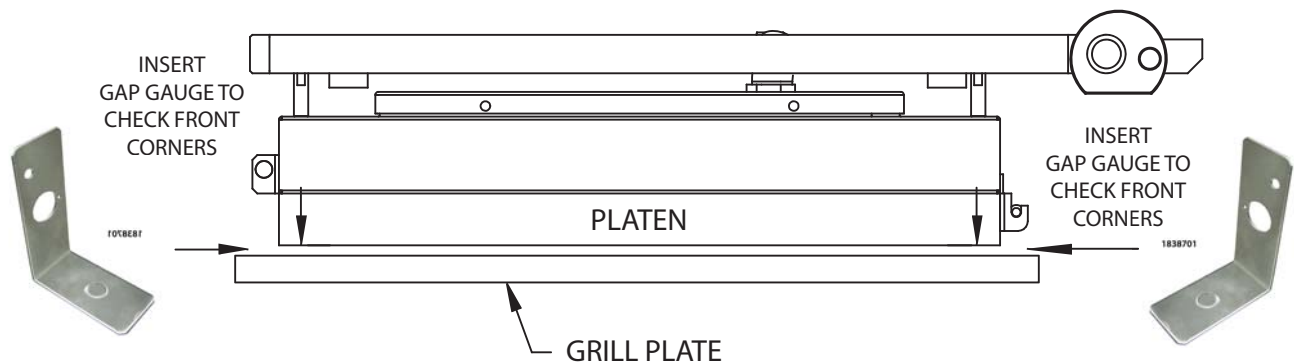

**PLATEN SIDE VIEW (Figure #2)**

# PLATEN LEVELING

## Platen Levelling Gauge Tool (figure 3)



Platen Levelling Gauge Tool  
Part #: [1838701](#)  
Setup gauge provided with the grill

## Gauge Tool Conventions (figure 4)



PASS – GO portion goes under platen but NOGO portion does not



Fail – GO portion does not go under platen



Fail – NOGO portion goes under platen

# PLATEN LEVELING

## Proper set up of adjuster nuts

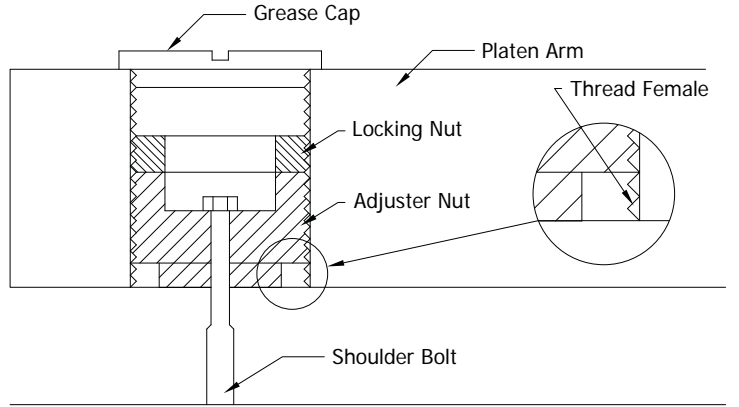

Figure # 5 - No more than two (2) threads female, as per diagram showing above

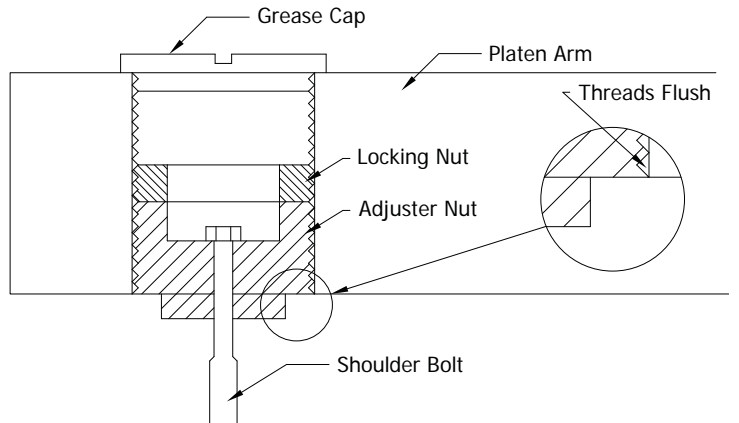

Figure # 6 - Desired position, both threads flush, as per diagram showing above

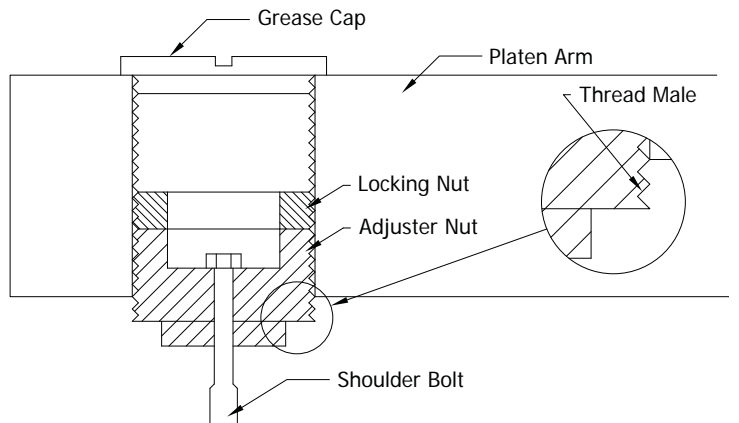











Figure # 7 - No more than two (2) threads male, as per diagram showing above

# TO SET REED SWITCHES

In order to ensure that the platen reed switches are in their proper location, you must ensure that the distance of the magnet is the correct distance away from the switch (located inside the upper platen).

Note: If not already in the "LEVEL/REED SW" mode, enter, if in "LEVEL/REED SW" mode already go to step #2.

1. Enter the "LEVEL/REED SW" mode:
  - a) With the controller display ON and either displaying the current menu item or displaying "OFF" PRESS and HOLD the  button for 3 seconds. Controller will display previously selected menu item and its corresponding item number OR "Standby / Menu Item".
  - b) PRESS the  AND  arrow buttons TOGETHER for approximately 3 seconds and "CONFIGURE" will appear in the display.
  - c) PRESS the  2X. "CALIBRATION" appears.
  - d) PRESS the  button. "LEVEL/REED SW" appears.
  - e) PRESS the  button. "NO" will begin to flash.
  - f) PRESS the  button. "NO" will change to "YES".
  - g) PRESS the  button. "YES" will stop flashing.
  - h) Press the  GREEN button to lower the platen.
2. Remove the reed switch grease caps.
3. Remove the reed switch locking caps.

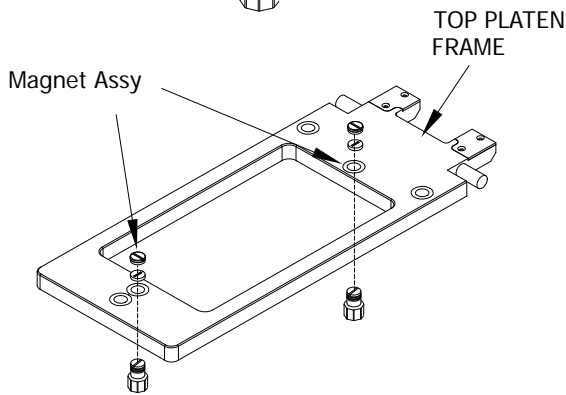

4. Using the Platen Adjusting Tool or a flat scredriver, screw the magnet down (clockwise) UNTIL the controller sounds a hi pitched BEEP.

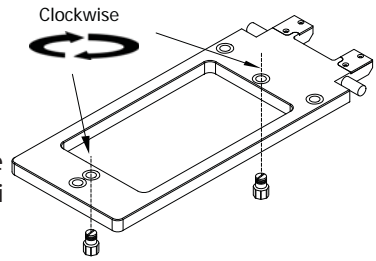

5. Screw the magnet UP (counter-clockwise) UNTIL the hi-pitched BEEP STOPS.

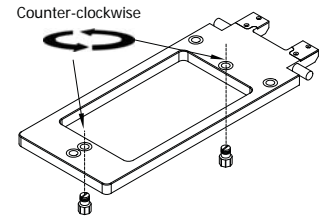



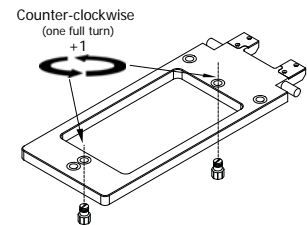

6. Screw the magnet counter-clockwise one, (1), more full turn (360°)



7. Repeat the procedure for the opposite reed switch.
8. Screw down reed switch locking caps.

**Note:** it is necessary hold the magnet in place when screwing down the locking cap.

9. After setting the reed switches as described, you must perform a Forced Auto Calibration. Press the  GREEN button to raise the platen.
10. PRESS  until "AUTO GAP FORCE" appears.
11. PRESS the  button. "NO" will begin to flash.
12. PRESS the  button. "NO" will change to "YES".
13. PRESS the  button. The platen will immediately lower and reset its internal measurements.
14. Reinstall grease caps.

## TO REPLACE MAGNET ASSEMBLY

1. Remove grease cap and lock nut.
2. Using the platen adjusting tool or a flat screwdriver, screw the magnet CLOCKWISE out of the bottom of the platen arm assembly.

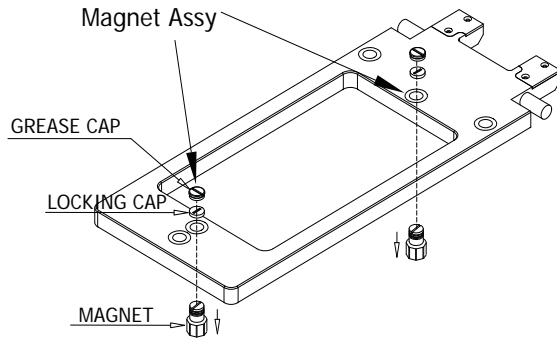

3. If the magnet does not clear the platen arm assembly, lower the gap adjustment in the front to give clearance for the magnet assembly.
4. Install new magnet assembly from the bottom up. Ensure proper magnet thread seating

5. Perform platen leveling procedure
6. Perform reed switch calibration procedure, refer to section; to set reed switches.



7. Thread lock nut in from the top and screw down to meet up with the aluminum magnet assembly
8. Use a wrench to hold the magnet assembly below the arm to prevent it from rotating while you use the platen adjust screw or a screwdriver to jam the lock-nut against the magnet assembly

# TO REPLACE THE REED SWITCH



## HIGH VOLTAGE

Reed switches carry high voltage. Disconnect power supply before starting this procedure



<p>1. Remove platen cover</p>	
<p>2. Remove wire connector cutting the wire right after the end of connector of the old reed switch.</p>	
<p><b>Note:</b> Mark wires for easy reconnection of new reed switch</p>	
<p>3. Remove reed switch bracket with 1/4" wrench or flat screwdriver</p>	

<p>4. Confirm that your positioning gauge is in square by checking it against the corner of the platen arm as shown on picture. Bend for complaint fit if necessary.</p>	
<p>5. Reinstall reed switch bracket using the positioning gauge. Align pushing in the direction shown, and tighten securely.</p>	
<p>6. Insert the insulation stretch sleeve in the wire, strip wires, insert a new connector then using a crimp plier crimp both end connector.</p>	
<p>7. Slice insulation over the connector and reinstall platen cover.</p>	

# REED SWITCH OPERATION

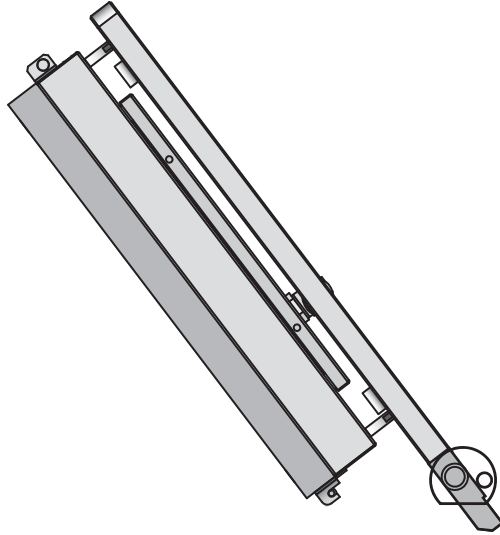
The Motor Speed Control is equipped with LED light that indicates the state of the reed switches (Front & Rear), and the limit switches (Upper & Lower). The LED light is ON when the state of the switch is OPEN. The LED light is OFF when the state of the switch is CLOSED. (LED colors may vary)



-  = LED not lighted / Switch Is CLOSED
-  = LED lighted / Switch Is OPEN

## PLATEN UP

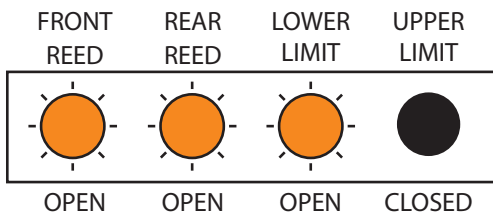
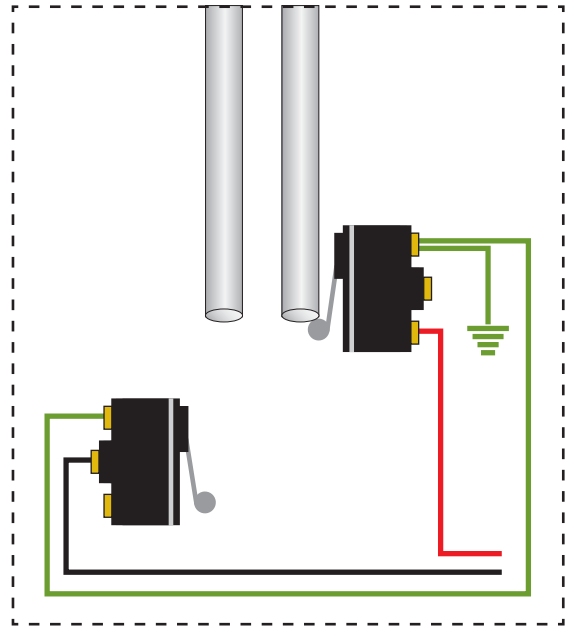



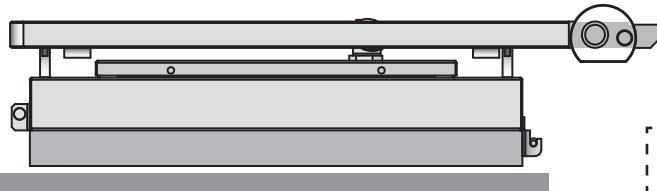



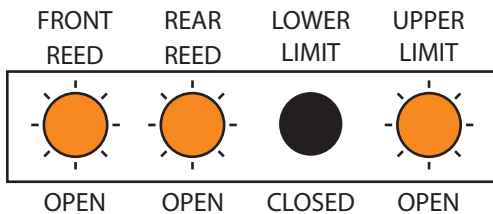
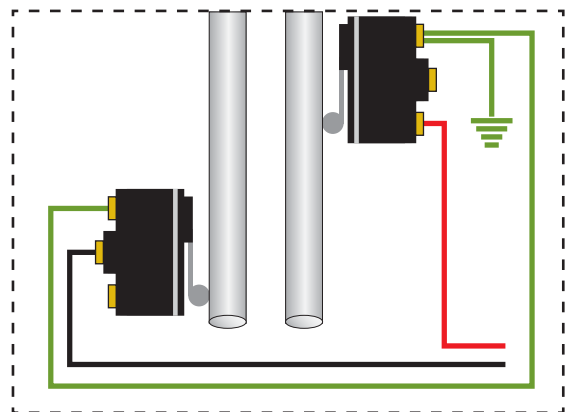





































NORMAL state of the switches when the platen is in the UP position.



## PLATEN DOWN



## REED SWITCH OPERATION (CONTINUED)

FRONT REED	REAR REED	LOWER LIMIT	UPPER LIMIT	
 OPEN	 OPEN	 OPEN	 CLOSED	Platen in the Up Position – Switches are in NORMAL state.
 OPEN	 OPEN	 OPEN	 OPEN	Platen movement command has been initiated. Upper Limit switch as OPENED.
 OPEN	 OPEN	 CLOSED	 OPEN	Platen has moved to the DOWN position. Lower Limit switch has CLOSED.
 OPEN	 OPEN	 OPEN	 OPEN	Platen has raised up to PREHEAT GAP SETTING of .450. Lower Limit Switch OPENS.
<b>AUTO CALIBRATION BEGINS AFTER GRILL REACHES TEMPERATURE AND COUNTDOWN TIMER EXPIRES.</b>				
 OPEN	 OPEN	 CLOSED	 OPEN	Auto calibration begins. Lower Limit Switch CLOSES
 OPEN	 CLOSED	 CLOSED	 OPEN	Platen continues to move down. Rear Reed Switch CLOSES.
 CLOSED	 CLOSED	 CLOSED	 OPEN	Platen continues to move down. Front Reed Switch CLOSES.
 OPEN	 CLOSED	 CLOSED	 OPEN	Linear Actuator reverses polarity. Platen Raises. Front Reed Switch OPENS.
 OPEN	 OPEN	 CLOSED	 OPEN	Platen continues to rise. Rear Reed Switch OPENS.
 OPEN	 OPEN	 OPEN	 OPEN	Platen continues to ruse. Lower limit switch opens.
 OPEN	 OPEN	 OPEN	 CLOSED	Platen continues to ruse. Upper Limit switch OPENS. Movement stops.

# TO REPLACE THE REED SWITCH (CONTINUED)

## Explanation of calibration numbers, auto calibration, and other Reed Switch variables.

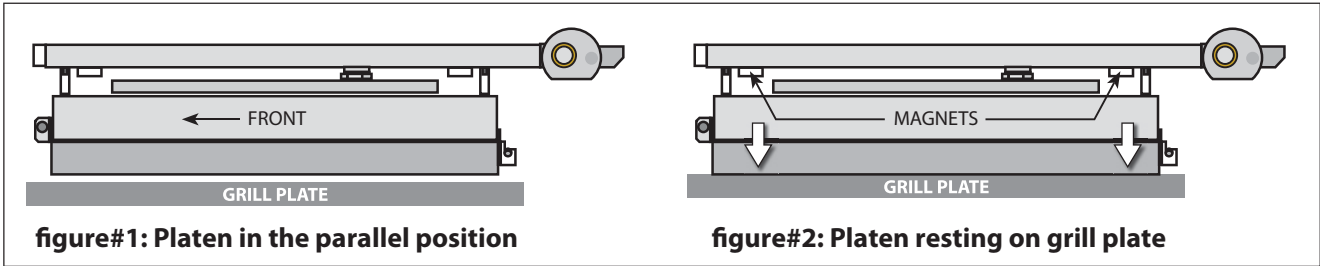

After the platen reaches the parallel position (figure #1), the actuator will continue to run bringing the platen to a resting position on the grill plate as shown (figure#2).

Once the platen is resting on the grill surface, the linear actuator will continue to run, lowering the platen arm even more, causing the shoulder bolts to ride up into the arm. **This is the reason why the lock nuts are hollowed out all the way through.**

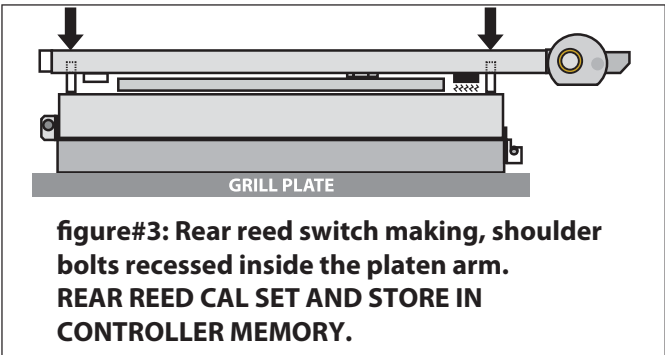

While the platen arm is lowering, the rear reed switch is closed when it makes contact with the magnet mounted on the arm. The number of counts from 0 gets stored in the control as **BACK REED CAL** (figure #3).

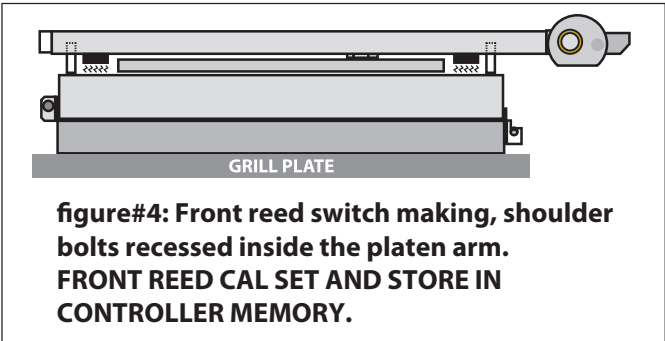

The linear actuator will continue lower bringing the platen arm down until the front reed switch makes contact with the magnet. The number of counts from 0 gets stored in the control as **FRONT REED CAL** (figure#4).

The timeline (figure#5), shows negative actuator movement, (platen arm downward), and the sequence in which difference points are achieved. Point 1 represents the number of encoder counts from 0 at which the rear reed switch closed (or made contact with the magnet). 2 is the number of encoder counts from 0 that the front reed switch closed (or made contact with the magnet).

**IMPORTANT** – The number of encoder counts between points 1 & 2 is **DELTA CAL (ΔCAL)**. **ΔCAL** must be **below 200**. The following conditions apply:

**ΔCAL < 200:** OK

**ΔCAL > 200, < 300:** "Check Platen Level" (Disables Auto Mode, allows operation in Manual Mode only.)

**ΔCAL > 300:** "Platen Not Level / Use Flat Cook" (Disables all clamshell cooking.)

During auto calibration, after the front reed switch is made, polarity and actuator direction are reversed, (ClipboardPageNumber.6). The actuator raises the platen arm, referencing point 3 when the **front** reed switch reopens, as **FRONT ZERO CAL**. Point 4, when the **rear** reed

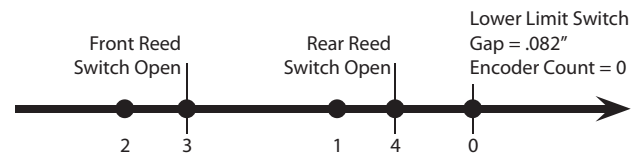
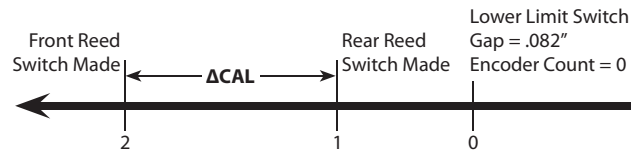

## TO REPLACE THE LINEAR ACTUATOR

1. Cut the plastic tie holding wire, remove screws (2) of clip, and disconnect the cable from the Motor Speed Control Board.

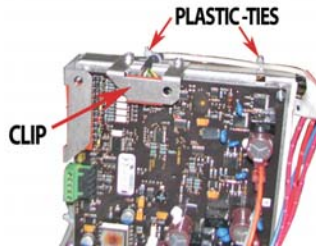

2. Disconnect the motor leads from the wire harness. Mark wires connector or make notes for future reconnection.

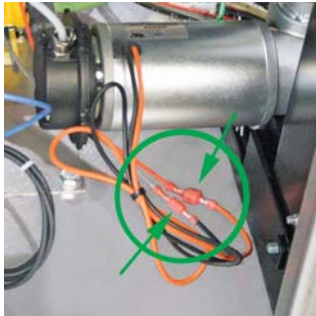

3. With the platen in the **UP** position, support it with a pry bar, 2x4, etc., from behind the platen arm assembly. Pull the platen arm toward the rear of the grill to insert.

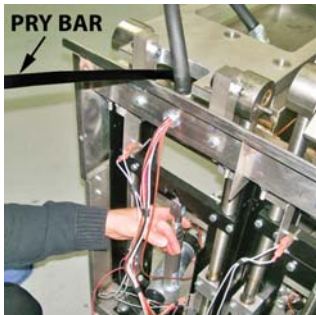

4. With the weight of the platen supported by the object inserted in step , use pliers to work the clevis pin retaining clip outward, making sure to grip it as close to the pin as possible to prevent deforming it.



5. Use the pliers to remove the spring clip from the pin at the base of the linear actuator.

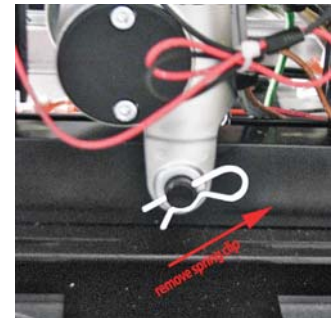

6. Push the pin through the actuator base toward the inside of the grill. Reach around to the inside and remove.

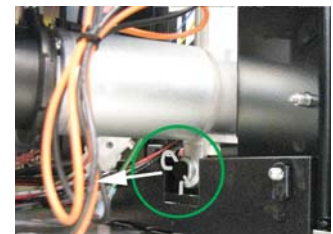

7. Remove the Linear Actuator from the grill, carefully pulling it out the rear.



# TO REPLACE THE LINEAR ACTUATOR (CONTINUED)

- 8. Support the weight of the platen while removing the pry bar. Then, carefully lower platen to the down position, resting it on the grill plate.



- 9. Turn NEW linear actuator shaft clockwise to the end, then turn it anti-clockwise approximately 2 turns, the shaft will move up. DO NOT detach or loosen clevis from shaft. Clevis pin should be parallel to actuator motor. Procedure mentioned is critical for a proper actuator function.

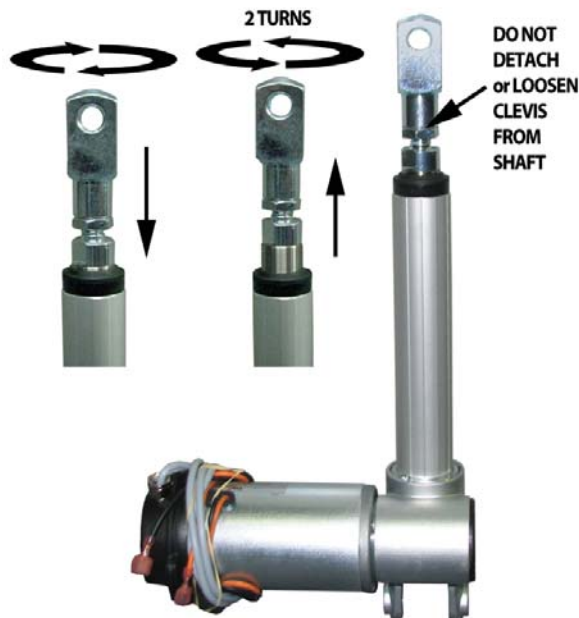

- 10. Re-install linear actuator into rack assembly. If motor does not clear the cross member, use pry bar to gently lift and fit as previous done in step 3. Reinstall actuator base pin from inside and remount its spring clip.

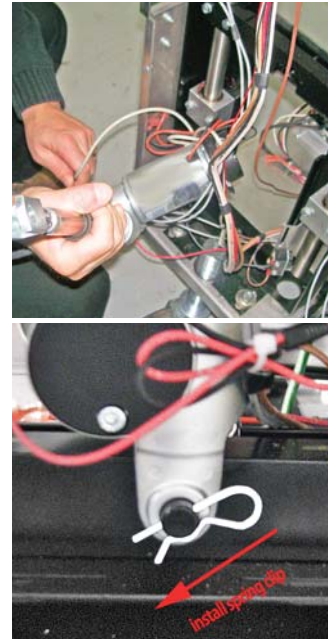

- 11. Gently fit clevis clip through top of actuator shaft and cross member bar. Use pry bar to align holes.

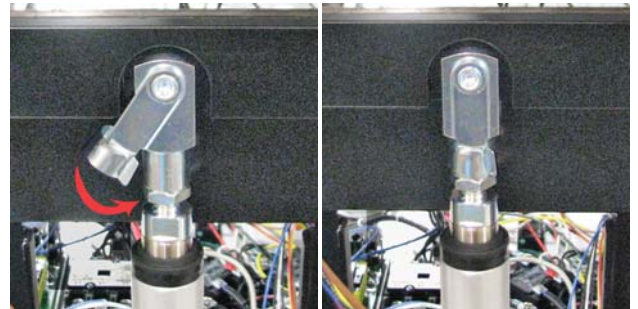

- 12. Follow procedures 1 & 2 reversing the steps. Clip must installed in place to secure plug. Replace plastic-ties by new ones.

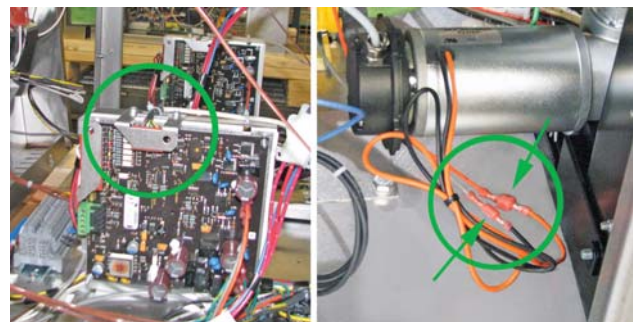

# TO REPLACE TOP PLATEN ASSEMBLY



**Danger**

**Turn Off Gas Supplies When Installing or Servicing Unit.**



**HIGH VOLTAGE**  
Disconnect power supply before starting this procedure

Safety First; Disconnect unit from electric and gas supplies prior to performing the follow service procedure.



1. Remove Teflon sheet and accessories, if installed.
2. Remove four screws located at the side of the platen cover, as shown in image.
3. Remove side mount bracket.
4. Keep parts removed in is a save place for later reinstallation.

CAUTION-FIBREGLAS



**DUST RESPIRATOR MUST BE WORN ON THIS JOB**

5. Remove fiberglass insulation. (Respirator protection must wear)



6. Mark all wires for easy reconnect ion.
7. Disconnect all wires nuts from element and screws from the high limit switch.



8. Cut wire from reed switch as close as possible from the connector as image shown (discard connector).
9. Place cover aside.

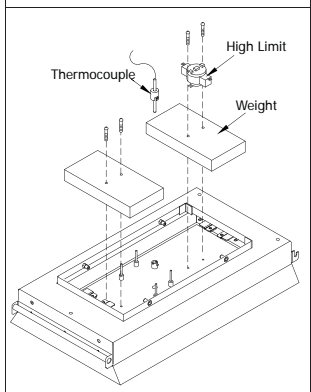

10. Remove high limit switch, save screws for later reinstallation.
11. Remove weight and mark them for easy reinstallation - some models weight are different.

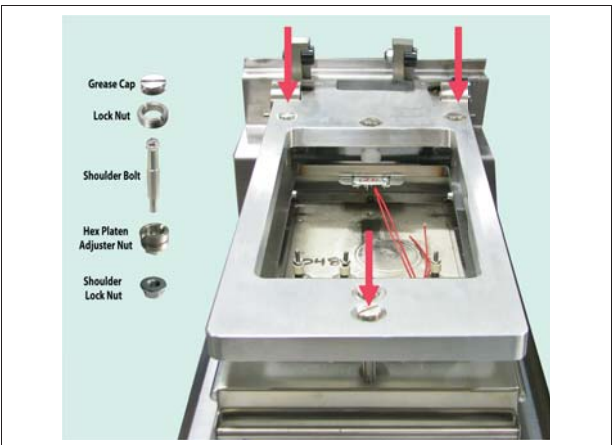

12. Place a cardboard or rag between both surfaces to protect grill surface from scratches.
13. Remove Grease cap using adjuster tool.
14. Remove lock nut using adjuster tool.

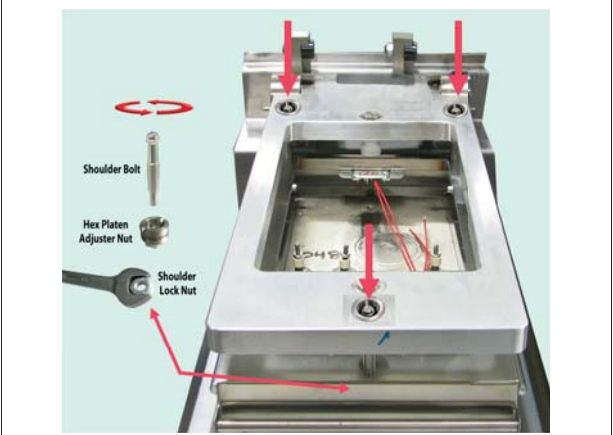

15. Place a 7/16 (11mm) wrench, inside the platen, to hold the shoulder nut.
16. Place a socket 5/16 (8mm) on the shoulder bolt and turn counterclockwise and remove.
17. Replace top platen and install new part reversing the steps mentioned.

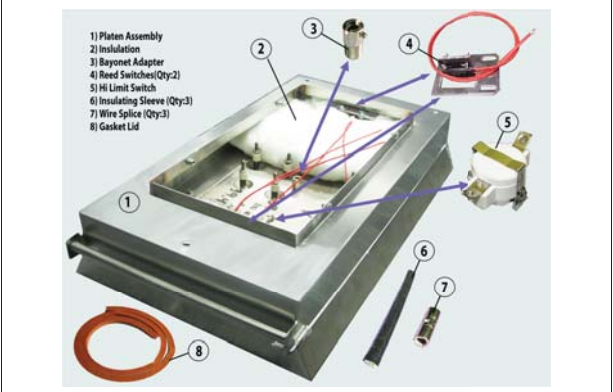

18. Photo shown parts included in a new top platen.
19. Refer to platen leveling procedure as last step.

## TO REPLACE THE SHAFT SEALS

1. Top platen be in the upper position when replacing the shaft seal. With the control in the OFF mode, press green button to upper platen, then turn the main switch OFF.



2. Remove back panel to access seal cap mounting bracket, hold bracket while taking screws off the seal cap.



3. Using a 1/4" socket, remove screws from seal cap to expose the old shaft seal underneath.



4. Lift up the seal cap through shaft and replace old shaft seal by the new split shaft seal.



5. Remove old screw o-rings and replace by new o-rings. Reinstall seal cap in place and slightly tighten screws DO NOT OVER-TIGHT. Turn main power switch on, the platen will lower, press green button to raised and lowered the platen a couple times. Final step tighten the seal cap screws down firm in place.

## TO REPLACE THE SHAFT SEALS & CAP O-RINGS

1. It is recommended that the platen be in the down position when replacing the shaft seals. With the control in the OFF mode, Press the GREEN push button to lower platen.



## TO REPLACE THE SHAFT SEALS & CAP O-RINGS (CONTINUED)

2. Remove carriage block locking key from carriage block using a 7/16" wrench or socket to unscrew two screws. The locking key will allow the platen arms to separate from the shafts without having to remove the entire shaft assembly.

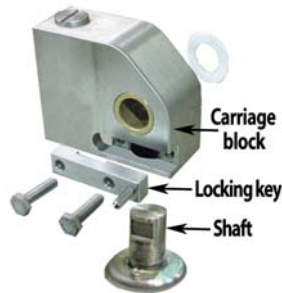

3. Carefully lift platen assembly of shaft assembly and place gently on grill plate. Protect grill surface with a piece of cardboard or rag to avoid scratches on grill surface.



4. Using a nut driver or a 1/4" ratchet, remove seal cap to expose shaft seal underneath seal cap. Support the seal cap retaining bracket on the underside of the back splash.



5. Remove old shaft seal, O-ring seal cap & screws o-rings, and install new ones.

6. Reinstall seal cap over shaft and tighten down loosely, the over tight will be at the last step.



7. Attach carriage blocks assembly to the both side of the platen arm assembly. Ensure that the Teflon washer is in place between the platen arm assembly and the carriage block assembly.



## TO REPLACE THE SHAFT SEALS & CAP O-RINGS (CONTINUED)

8. Carefully lift platen arms up and place back onto shaft assembly. Reinstall carriage block locking key into carriage block, tighten 7/16" bolts.



9. Once all of the mechanical components have been reassembled (remove tools or any other objects from grill), turn main power switch to the On position. The platen will raise to the up position.



MAIN POWER SWITCH



PUSH BUTTON - GREEN

10. With the seal cap still not tightened down completely, wear the new seal in by lowering and raising the platen at least twice by pushing the Green button.

11. Finally tighten the seal cap down, gentle tight.



## TO UPDATE MAIN CONTROL SOFTWARE

THE FOLLOWING INSTRUCTIONS ARE FOR USE WITH THE GARLAND ZIPGRADER TO UPLOAD NEW CONTROL SOFTWARE INTO WATLOW CONTROL (PN [4526975](#)) AND WATLOW MOTOR CONTROL (PN [4521682](#)).

To connect and upgrade main control (pn [4526975](#))

1. Remove upper push-button panel and lower control panel.
  - a. Remove upper panel screws to release panel.
  - b. Carefully lower panel and place it on floor.
  - c. Do not disconnect main power switch plug for later use.



2. Attach RJ11 - 6 conductor Modular Telephone Cable to ZipGrader & Control.
  - a. Attach one end of cable to Zip-Grader.



- b. Disconnect any LonWorks cable that are attached to the control jack, and attach opposite end of cable to controller. Control jack is on the bottom side of the controller.

## TO UPDATE MAIN CONTROL SOFTWARE *(CONTINUED)*



RJ11 - 6 Conductor  
Modular Telephone Cable

Control Jack (use either port)

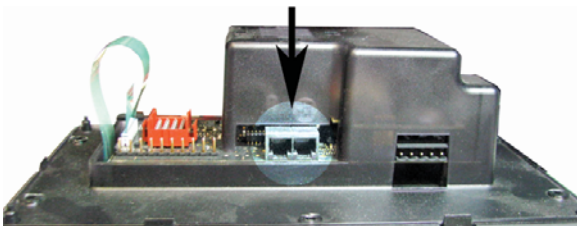

5. Control upgrade is complete when the control displays FULL DEFAULT and then returns to the OFF position. WAIT FOR THE ZIPGRADER TO AUTOMATICALLY TURN OFF.



3. Enter programming mode by:
  - a. PRESS AND HOLD the TEMP & CLOCK buttons on the control. Turn main power switch on WHILE HOLDING two buttons in. Hold for approximately 3 seconds. Control will turn on as normal.

Note: If you are flashing the control w/ the same revision of software that was previously installed, FULL DEFAULT will not occur.



6. Turn main power switch OFF.
7. Remove RJ11 telephone cable from control, and insert into additional controls.
8. Reconnect any LonWorks cables that were previously connected.
9. Repeat steps 4-8 until all lanes are flashed

- b. Turn main power switch OFF and wait for 10 seconds.



- c. Turn main switch ON. Control should read something similar to "MOD BOOT"
4. Begin Uploading software by:
  - a. Press ZipGrader BLUE button.
  - b. Monitor Serial Link and progress LED's as indicated on the back of the ZipGrader.

## TO UPDATE MOTOR CONTROL SOFTWARE

1. Remove upper pushbutton panel and lower control panel.

- a. Remove upper panel screws to release upper panel.
- b. Carefully lower upper panel and remove lower control panel screws on both left and right sides.



- c. Remove kick panel and place on floor.
- d. Disconnect connector plugs to allow for relocation of the lower control panel. Do not disconnect main power switch plug for later use.

2. Attach RJ11 - 6 conductor Modular Telephone Cable to ZipGrader & Motor Speed-Control (MSC) board.

- a. Attach Cable to the ZipGrader
- b. Attach opposite end of cable to Motor Speed Board Adapter Kit.
- c. Remove 5-pin Riacom Connector COMM CABLE from Motor Speed Control board and connect ZipGrader to msb.

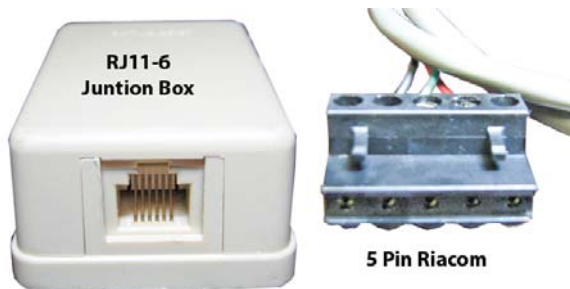

3. Begin uploading software by :
  - a. With the power to the grill OFF, Press the ZipGrader BLUE button.
  - b. **Wait 5 seconds** before proceed to step c.
  - c. Turn grill power back on via the main power switch.

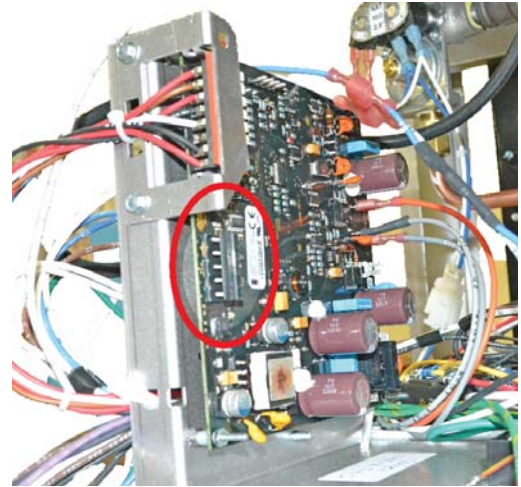

**Note: Control will alternately flash ERROR COMMS. (it's normal)**

- d. Progress LED's on ZipGrader should begin as indicated on rear of ZipGrader.



4. Allow ZipGrader to turn off automatically.
5. Turn Main Power Switch to OFF position.
6. Remove 5-pin Riacom connector from ZipGrader, and replace with 5-pin Riacom connector COMM Cable previously removed.
7. Repeat steps 3 to 6 to others MSC
8. Carefully replace bottom kick panel, and control panel can return unit to service :
  - a. Turn main power switch ON.
  - b. Press POWER ON button on main control.
  - c. Platens will automatically come down and into PREHEAT MODE.
  - d. Switch controls to desired time of day by pressing AM/PM button.
  - e. Allow unit to reach set temperature and autocalibrate.
  - f. Verify proper beef integrity and adjust cook times as needed in Manual Mode.

# ELECTRIC HEATING ELEMENTS

## UPPER PLATEN ELEMENTS: ALL GRILLS



3249 WATTS TOTAL (3 ELEMENTS @ 1083 WATTS EA)			
VOLTS	LINE AMPS	ELEMENT AMPS	RESISTANCE
208	9.02	5.20	33.95 Ω
220	8.53	4.92	44.69 Ω
240	7.82	4.51	53.20 Ω

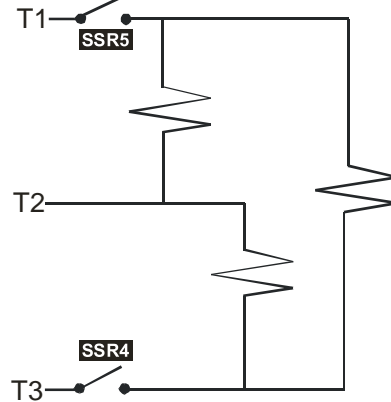
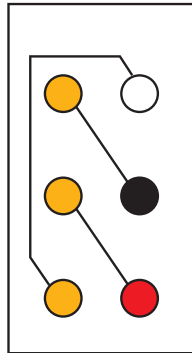

## GRILL SURFACE ELEMENTS: MWE3W

VOLTS	LINE AMPS	ELEMENT AMPS	RESISTANCE
<b>FRONT/REAR ELEMENTS: 1300 WATTS EA.</b>			
208	6.25	6.25	33.28 Ω
220	5.91	5.91	37.23 Ω
240	5.42	5.42	44.28 Ω
<b>CENTER ELEMENT: 1700 WATTS</b>			
208	8.17	8.17	25.46 Ω
220	7.72	7.72	28.50 Ω
240	7.08	7.08	33.90 Ω

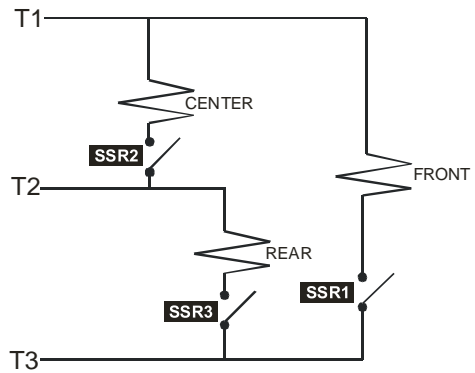
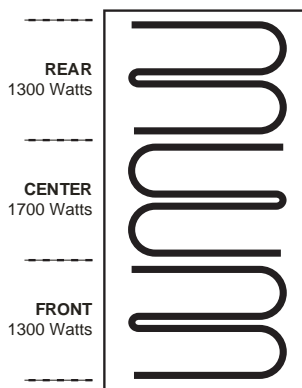

## INTERNAL COMPONENTS: MWE3W

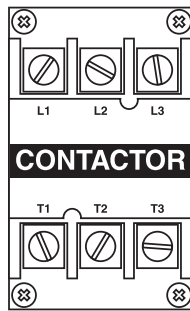
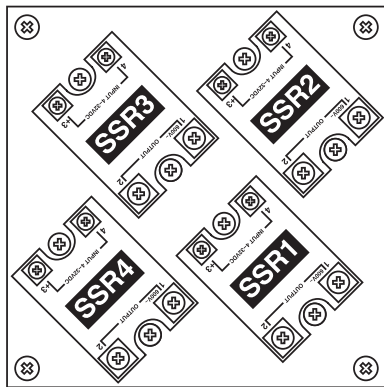

SOLID STATE RELAYS (SSR's)

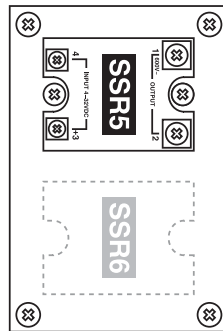

- SSR1 = GRILL SURFACE FRONT
- SSR2 = GRILL SURFACE CENTER
- SSR3 = GRILL SURFACE REAR
- SSR4 = UPPER PLATEN
- SSR5 = UPPER PLATEN
- SSR6 = EXPORT GRILLS ONLY



# ELECTRIC HEATING ELEMENTS

## UPPER PLATEN ELEMENTS: ALL GRILLS

FRONT OF GRILL

3249 WATTS TOTAL (3 ELEMENTS @ 1083 WATTS EA)			
VOLTS	LINE AMPS	ELEMENT AMPS	RESISTANCE
208	9.02	5.20	33.95 Ω
220	8.53	4.92	44.69 Ω
240	7.82	4.51	53.20 Ω

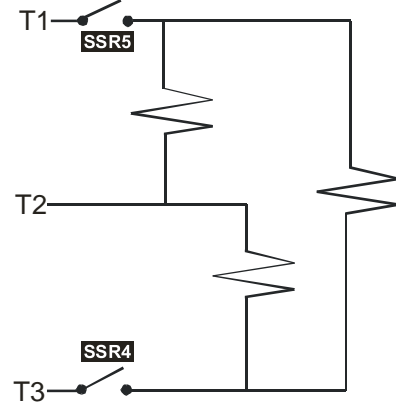
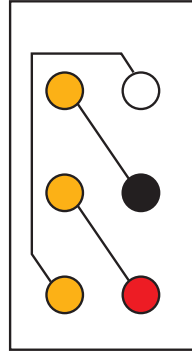

## INTERNAL COMPONENTS: MWG3W

SOLID STATE RELAYS (SSR's)

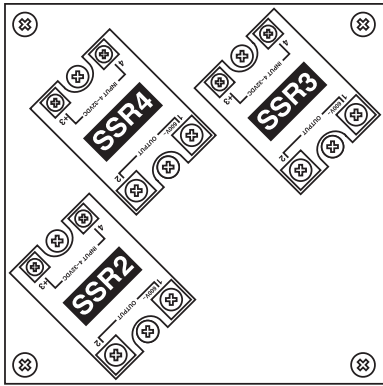

SSR2 = BURNER BLOWER  
 SSR3 = UPPER PLATEN  
 SSR4 = UPPER PLATEN

FRONT OF GRILL

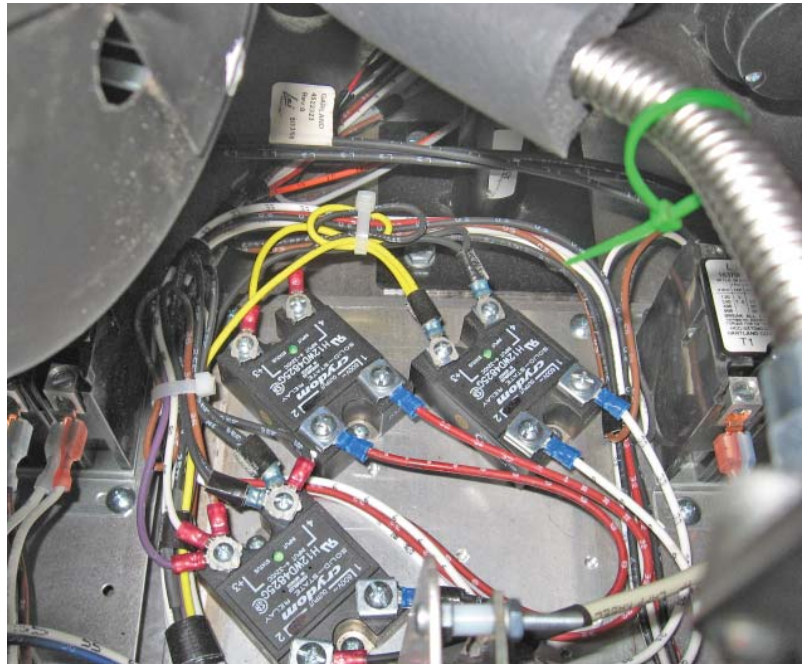

# TROUBLESHOOTING GUIDE INFORMATION

## Step to access error codes

The following procedures should be followed in sequence. Error codes description are print on the troubleshooting section of this book.



1. **Enter Programming** - Enter the program mode.
2. **Enter User Hist. Log** - Enter the area where codes get stored.

### 1. Enter Programming



1-1. PRESS and HOLD the  button for approximately 3 seconds. Controller will display previously selected menu item and its corresponding item number.



### 2. Enter User Hist. Log (error codes)

2-1. PRESS & HOLD  and  simultaneously will display "CONFIGURE"



2-2. PRESS the  or  button until "SERVICE" is displayed.



2-3. PRESS the  button. The current "ENCODER COUNTS" is displayed.



2-4. PRESS the  or  button until "USER HIST. LOG" is displayed.



**NOTE:**

Top reading shows the quantity of errors occurred



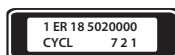

2-5. PRESS the  button. The last errors occurred will display. For more details see error logging interpretation.

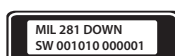

2-5. PRESS the  button to shown to second display.



2-6. Using  or  button, to shown to the next error if there is more than one.

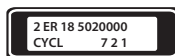

**NOTE:**

"This error will be always present as an older error".



# TROUBLESHOOTING GUIDE INFORMATION

## Step to delete error codes

The following procedures should be followed in sequence. Once the codes are resolved it's recommended that clear all codes from memory.



1. **Enter Programming** - Enter the program mode.
2. **Enter "Clear User Hist."** - Clear errors mode.

### 1. Enter Programming



1-1. PRESS and HOLD the  button for approximately 3 seconds. Controller will display previously selected menu item and its corresponding item number.



### 3. Enter "Clear User Hist." (delete errors)

3-1. PRESS & HOLD  and  simultaneously will display "CONFIGURE"





3-2. PRESS the  or  button until "SERVICE" is displayed.



3-3. PRESS the  button. The current "ENCODER COUNTS" is displayed.





3-4. PRESS the  or  button until "CLEAR USER HIST." is displayed.



3-5. PRESS the  button. The current setting will begin to flash.



3-6. Using  or  button, change the old setting to the new setting.



3-7. PRESS the  button to save the new setting.



3-8. PRESS the  twice to exit program mode.



# TROUBLESHOOTING GUIDE INFORMATION

## Motor Type Error Logging Interpretation

MOTOR TYPE  
- First Display

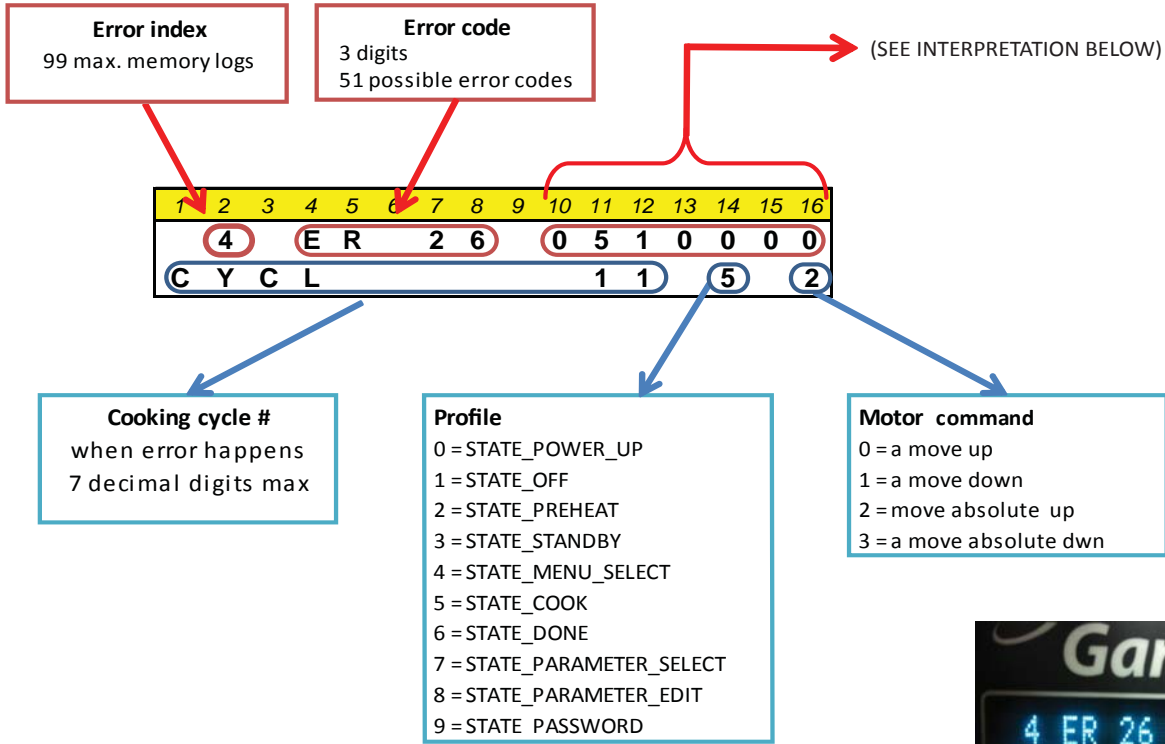

### 7 DIGITS HEXADECIMAL INTERPRETATION

Fault Code			
REED SW	REED MASK	UP/LOW SW.	Motor code
10	11	12	13 14 15 16
FR FL RR RL	FR RL RR RL	UL LL UM LM	

Reed SW Close	FR FL RR RL	Digit 10
None	0 0 0 0	0
RL	0 0 0 1	1
RR	0 0 1 0	2
RR, RL	0 0 1 1	3
FL	0 1 0 0	4
FL, RL	0 1 0 1	5
FL, RR	0 1 1 0	6
FL, RR, RL	0 1 1 1	7
FR	1 0 0 0	8
FR, RL	1 0 0 1	9
FR, RR	1 0 1 0	A
FR, RR, RL	1 0 1 1	B
FR, FL	1 1 0 0	C
FR, FL, RL	1 1 0 1	D
FR, FL, RR	1 1 1 0	E
FR, FL, RR, RL	1 1 1 1	F

**Digit 11**  
Similar to digit 10  
but use on Mask

**Digit 12**  
Similar to digit 10  
but use on UL, LL  
UM & LM

**Motor code**  
0x0000 = No Motor Error  
0x0001 = System Error  
0x0004 = Wrong Direction  
0x0008 = Encoder Sequence  
0x0010 = Over Current  
0x0020 = Hard Limit Reached  
0x0040 = Motor Not Running  
0x0100 = Voltage Out of Range  
0x0200 = Voltage Dipped Low  
0x4000 = Watchdog Reset

  

Acronyms  
 RL : Rear Left Reed Switch  
 RR : Rear Right Reed Switch  
 FL : Front Left Reed Switch  
 FR : Front Right Reed Switch  
 UL : Upper Limit Switch  
 LL : Lower Limit Switch  
 UM : Mask to Upper Limit Switch  
 LM : Mask to Lower Limit Switch

# TROUBLESHOOTING GUIDE INFORMATION

## Motor Type Error Logging Interpretation

**MOTOR TYPE**  
- Second Display

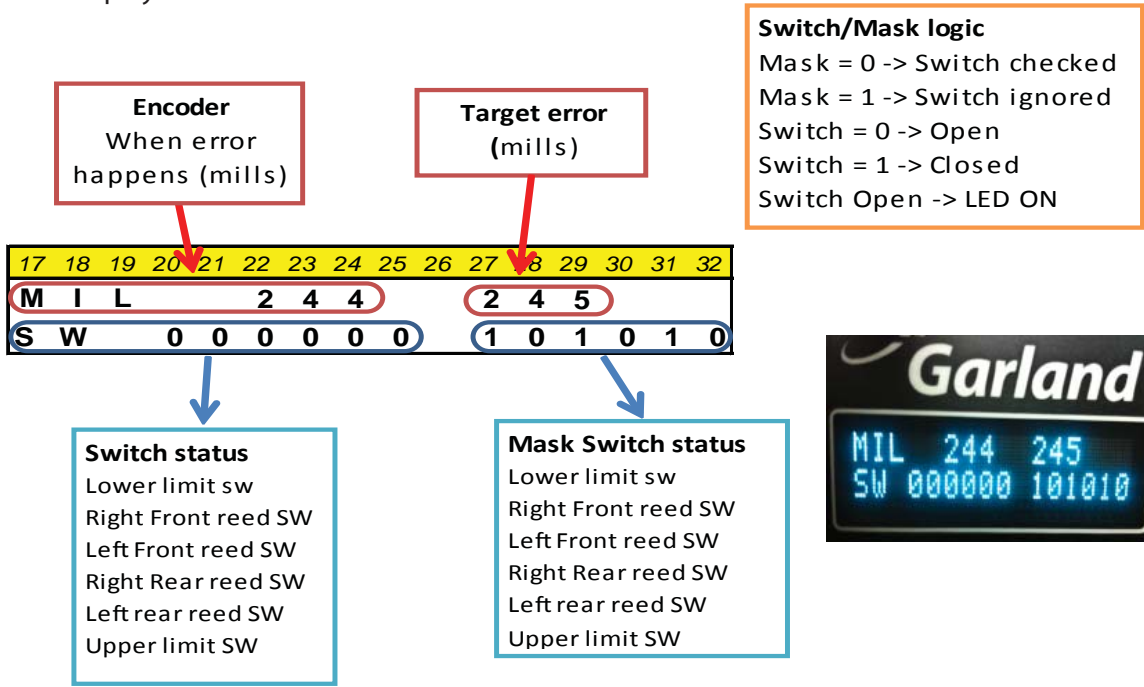

# TROUBLESHOOTING GUIDE INFORMATION

## Temperature Type Error Logging Interpretation

### TEMPERATURE TYPE

- First Display

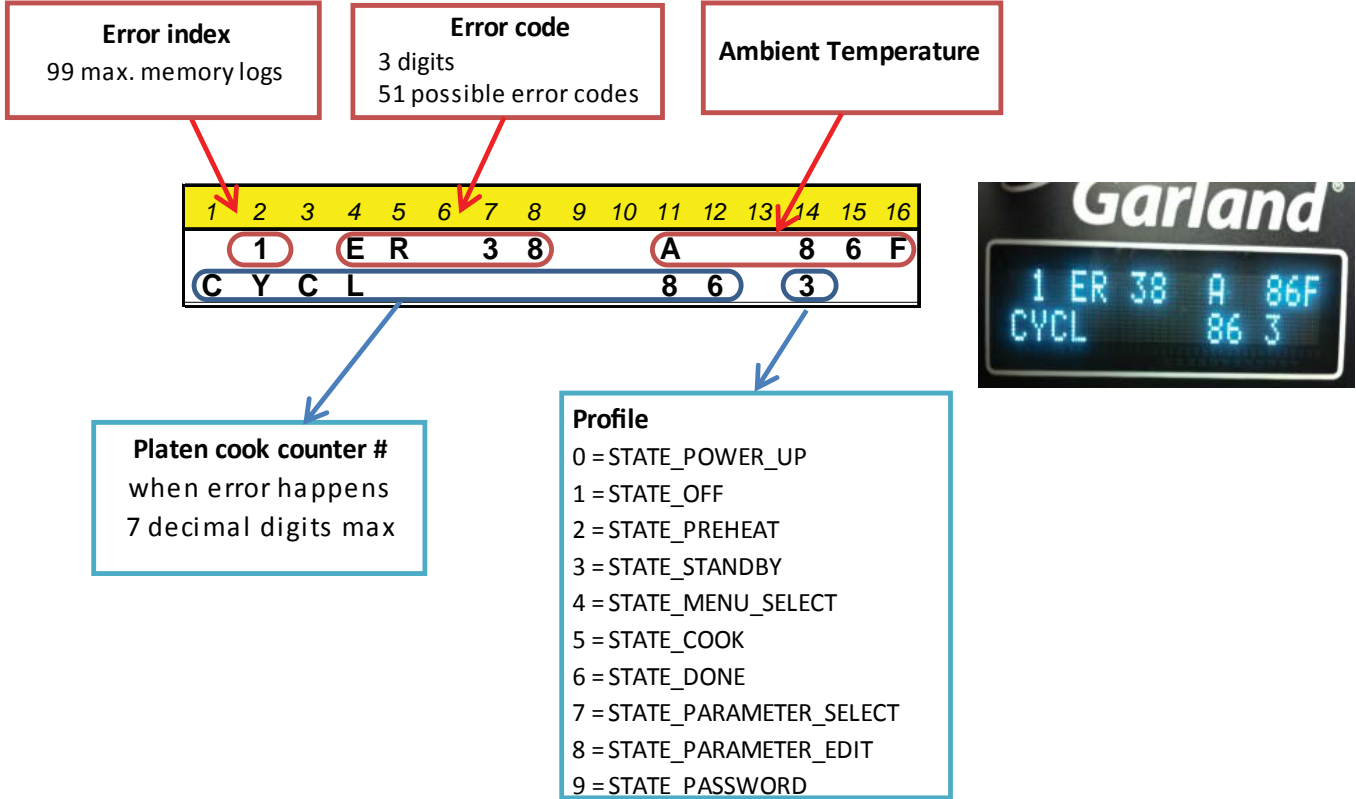

### TEMPERATURE TYPE (Electric)

- Second Display

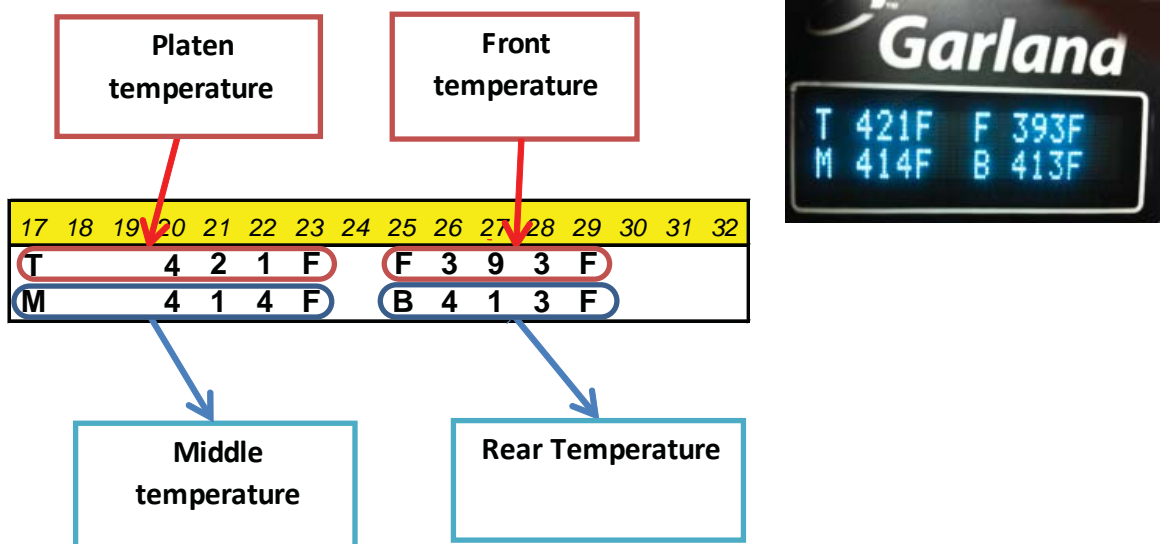

# TROUBLESHOOTING GUIDE INFORMATION

## Calibration Type Logging Interpretation

CALIBRATION TYPE  
- First Display

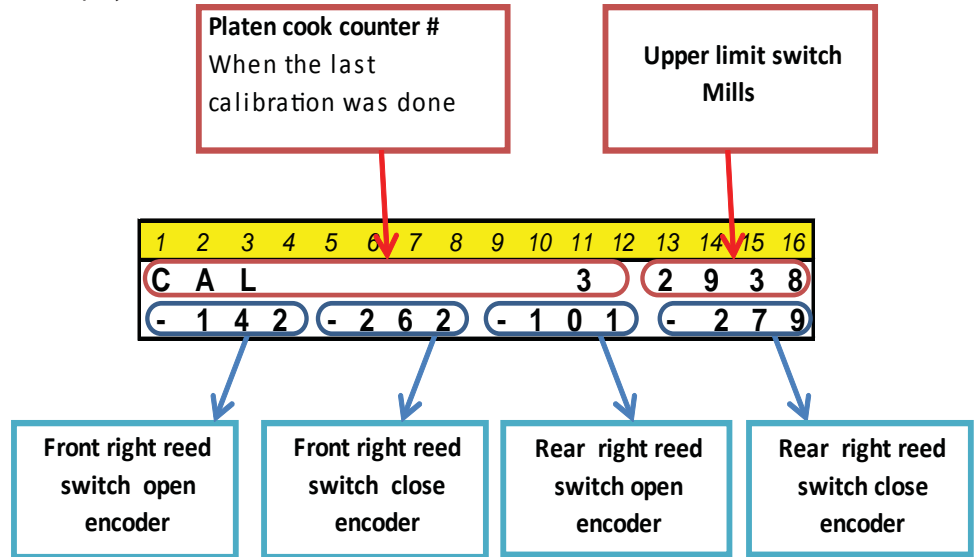

CALIBRATION TYPE  
- Second Display

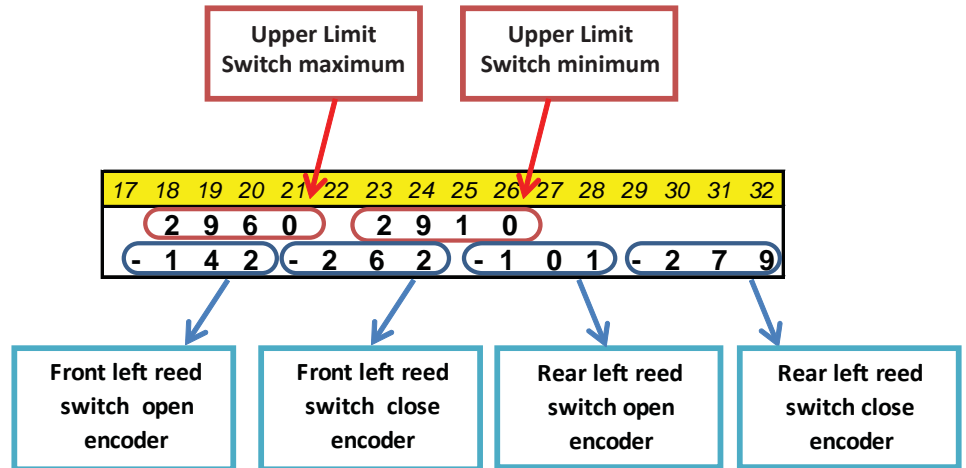
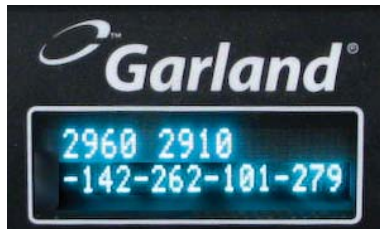

## ERROR CODES TROUBLESHOOTING GUIDE INFORMATION

### Acronyms Definition:

- ← This character indicates that the second line scrolls.
- LLS = Lower Limit Switch.
- MCB = Motor Control Board.
- ULS = Upper Limit Switch.



---

### Error code: 00

Message on Screen: ERROR

←PUSH GREEN BUTTON TO RETRY CALIBRATION

**Meaning of Error:** Motor Control board has detected missed counts. – Missing positional pulses detected. Position needs to be re-verified by locating lower limit switch.

**Error Logging Type: Motor** (More details page 80)

### Troubleshooting steps:

- Run drift check test. If actuator fails test, replace actuator. Restart grill and re-try.
  - Check actuator cables and connectors from Actuator to Motor control board are connected properly and not damaged. Check for insulation damage and loose, broken wires. If damage found, replaced damaged parts, restart grill and retry.
  - Swap MCB connections to the actuator between cook zones and see if issue follows the MCB or the Actuator. If error stays with MCB; replace MCB. If the error follows the Actuator; replace actuator. Restart grill and retry.
-

## **ERROR CODES TROUBLESHOOTING GUIDE INFORMATION**

### **Error code: 01**

**Message on Screen:** ERROR

←PUSH GREEN BUTTON TO CONTINUE

**Meaning of Error:** Motor Over-current Error. Too much current detected in Motor drive circuit.

**Error Logging Type:** Motor (More details page 80)

#### **Troubleshooting steps:**

- Check for obstructions to platen movement: i.e. egg ring, hood, Ansul nozzles, spatula, scraper, grease shield on platen back, improper install of Teflon rod, platen shaft seal popped out of position . If obstruction suspected, clear obstruction and retry grill operation.
- Check platen travel is correct to verify upper limit switch is located correctly. Verify platen cross member is not hitting flue inside grill back.
- Verify platen mechanism looks OK and bolts are tight. Check motor, platen rack, guide bearings, cross member
- Visually check that Lower limit Switch (LLS) is located properly compared to other lane(s)
- Verify motor operating properly, check motor ohm reading (correct reading goes here) .
- Swap MCB connections to the actuator between cook zones and see if issue follows the MCB or the Actuator. If error stays with MCB; replace MCB. If the error follows the Actuator; replace actuator. Restart grill and retry.

---

### **Error code: 02**

**Message on Screen:** ERROR

←PUSH GREEN BUTTON TO RETRY CALIBRATION

**Meaning of Error:** Motor Hard Limit Reached. Motor count position has gone out of normal range.

**Error Logging Type:** Motor (More details page 80)

#### **Troubleshooting steps:**

- Follow guidelines for error code 00, and follow the troubleshooting steps.
- Run leveling procedure on (More details page 80) .

## **ERROR CODES TROUBLESHOOTING GUIDE INFORMATION**

### **Error code: 03**

**Message on Screen:** ERROR

←PUSH GREEN BUTTON TO RETRY CALIBRATION

**Meaning of Error:** Motor Not Moving Error – No movement feedback from motor to MSC.

**Error Logging Type:** **Motor** (More details page 80)

**Troubleshooting steps:**

- Check for obstructions preventing the platen from lowering.: i.e. egg ring, hood, Ansul nozzles, spatula, scraper, grease shield on platen back, improper install of Teflon rod, platen shaft seal popped out of position . If obstruction suspected, clear obstruction and retry grill operation.
  - Check motor board and actuators cables and connectors, including motor encoder
  - Check actuator and motor control board with troubleshooting check list 4529505.
- 

### **Error code: 04**

**Message on Screen:** ERROR

←PUSH GREEN BUTTON TO RETRY CALIBRATION

**Meaning of Error:** Motor System Error

**Error Logging Type:** **Motor** (More details page 80)

**Troubleshooting steps:**

- Press green button to recalibrate to see if error repeats.
  - Check motor board and actuators cables and connectors
  - Run 4529505 checklist
- 

### **Error code: 05**

**Message on Screen:** No error on screen, error is logged only.

**Meaning of Error:** Voltage is detected to be less than 115V. or greater than 380V. with the motor not moving and with no requests for moving being seen.

**Error Logging Type:** **Motor** (More details page 80)

**Troubleshooting steps:**

- Verify voltage into Motor Control Board. Trace power from MCB to building and check for bad connections, failed insulation, loose plugs or terminals. Verify all phases and hood interlock circuit if applicable. Ensure good power coming to grill and power not in a “brown-out” or over voltage condition.
-

## **ERROR CODES TROUBLESHOOTING GUIDE INFORMATION**

---

### **Error code: 06**

**Message on Screen:** ← CYCLE ABORTED - PUSH GREEN BUTTON TO CONTINUE

**Meaning of Error:** Voltage is detected to be below 95V. while the motor is running.

**Error Logging Type:** Motor (More details page 80)

**Troubleshooting steps:**

- Verify voltage into Motor Control Board. Trace power from MCB to building and check for bad connections, failed insulation, loose plugs or terminals. Verify voltages of all phases and hood interlock circuit if applicable. Ensure good power coming to grill and power not in a “brown-out” condition.
- 

### **Error code: 10**

**Message on Screen:** ERROR

←PUSH GREEN BUTTON TO RETRY CALIBRATION

**Meaning of Error:** Motor Wrong Direction – Motor movement is in the wrong direction.

**Error Logging Type:** Motor (More details page 80)

**Troubleshooting steps:**

- Verify Actuator wires are connected correctly.
  - Verify the Actuator Encoder connector is not installed backwards.
- 

### **Error code: 12**

**Message on Screen:** ERROR

←CHECK FOR OBJECT UNDER PLATEN - PUSH GREEN BUTTON TO CONTINUE

**Meaning of Error:** Platen Lower Time-out. The platen exceeded the maximum allowable time to lower.

**Error Logging Type:** Motor (More details page 80)

**Troubleshooting steps:**

- Check for obstructions preventing the platen from lowering.: i.e. egg ring, hood, Ansul nozzles, spatula, scraper, grease shield on platen back, improper install of Teflon rod, platen shaft seal popped out of position . If obstruction suspected, clear obstruction and retry grill operation.
  - Run checklist 4529505
-

## **ERROR CODES TROUBLESHOOTING GUIDE INFORMATION**

---

### **Error code: 13**

**Message on Screen:** ERROR

←CHECK FOR PLATEN JAM - PUSH GREEN BUTTON TO CONTINUE

**Meaning of Error:** Reed Switch Stuck closed - at start of down motion during cooking or ship move.

**Error Logging Type:** Motor (More details page 80)

**Troubleshooting steps:**

- Check for obstructions preventing the platen from lowering.: i.e. egg ring, hood, Ansul nozzles, spatula, scraper, grease shield on platen back, improper install of Teflon rod, platen shaft seal popped out of position . If obstruction suspected, clear obstruction and retry grill operation.
  - Check if platen hung up on shoulder bolts and not dropping back down.
  - Check for obstructions to platen movement that could result in reed switch not reopening. Observe if the platen is hanging correctly off the shoulder bolts and is free to move.
  - Retry calibration. If this fails again, level platen and adjust magnets.
- 

### **Error code: 14**

**Message on Screen:** ERROR

←CHECK FOR PLATEN JAM - PUSH GREEN BUTTON TO RETRY CALIBRATION

**Meaning of Error:** Reed Switch Stuck during Platen Level – During one or more platen leveling procedure, reed switches did not close (downward movement) or open (upward movement) reed switches do not all close on the way down or reopen on the way back up during platen Leveling.

**Error Logging Type:** Motor (More details page 80)

**Troubleshooting steps:**

- Check for obstructions to platen movement that could result in reed switch not reopening. Observe if the platen is hanging correctly off the shoulder bolts and is free to move.
  - Retry calibration. If this fails again, level platen and adjust magnets.
  - If this does not correct issue, observe LED's on motor board to determine which switch is not working properly. Replace reed switch.
-

## **ERROR CODES TROUBLESHOOTING GUIDE INFORMATION**

---

### **Error code: 15**

**Message on Screen:** ERROR

←CHECK FOR PLATEN JAM - PUSH GREEN BUTTON TO RETRY CALIBRATION

**Meaning of Error:** Reed Switch stuck closed after Preheat

**Error Logging Type:** Motor (More details page 80)

**Troubleshooting steps:**

- Check for obstructions to platen movement that could result in reed switch not reopening. Observe if the platen is hanging correctly off the shoulder bolts and is free to move.
  - Retry calibration. If this fails again, level platen and adjust magnets.
  - If this does not correct issue, observe LED's on motor board to determine which switch is not working properly. Replace reed switch.
- 

### **Error code: 16**

**Message on Screen:** ERROR

←PUSH GREEN BUTTON TO CONTINUE

**Meaning of Error:** One or more reed Switch(s) did not open after product recognition.

**Error Logging Type:** Motor (More details page 80)

**Troubleshooting steps:**

- Check for obstructions to platen movement that could result in reed switch not reopening. Observe if the platen is hanging correctly off the shoulder bolts and is free to move.
  - Retry calibration. If this fails again, level platen and adjust magnets.
  - If this does not correct issue, observe LED's on motor board to determine which switch is not working properly. Replace reed switch.
-

## **ERROR CODES TROUBLESHOOTING GUIDE INFORMATION**

---

### **Error code: 18**

**Message on Screen:** ERROR

← PUSH GREEN BUTTON TO CONTINUE OR PUSH GREEN BUTTON TO RETRY CALIBRATION

**Meaning of Error:** Lower Limit Switch Failure during ship position or calibration.

**Error Logging Type:** Motor (More details page 80)

**Troubleshooting steps:**

- Cycle power and re-check
  - Verify LLS LED on motor board., Check wires and connections between Lower switch and Motor control board. Check operation of Lower switch with continuity check. If switch is bad, replace switch.
- 

### **Error code: 19**

**Message on Screen:** ERROR

← PUSH GREEN BUTTON TO RETRY CALIBRATION

**Meaning of Error:** Platen is found to not be level during calibration.

**Error Logging Type:** Motor (More details page 80)

**Troubleshooting steps:**

- Retry calibration with a power cycle or a force calibration.
  - Check adjusters and lock rings for loose fasteners
  - Level platen, adjust magnets and recalibrate.
  - If other methods do not work, replace reed switch with abnormal calibration value or switch where magnet is adjusted differently than the others.
-

## **ERROR CODES TROUBLESHOOTING GUIDE INFORMATION**

### **Error code: 20**

**Message on Screen:** ERROR

←CHECK FOR OBJECT UNDER PLATEN - PUSH GREEN BUTTON TO CONTINUE

**Meaning of Error:** Target Position Not Reached – The Platen move command did not end up at the correct position

**Error Logging Type: Motor** (More details page 80)

**Troubleshooting steps:**

- Check for obstructions to platen movement: i.e. egg ring, hood, Ansul nozzles, spatula, scraper, grease shield on platen back, improper install of Teflon rod, platen shaft seal popped out of position . If obstruction suspected, clear obstruction and retry grill operation.
- Check actuator and motor control board with troubleshooting check list 4529505.

---

### **Error code: 21**

**Message on Screen:** OBSTRUCTION

←CHECK FOR OBJECT UNDER PLATEN - PUSH GREEN BUTTON TO CONTINUE

**Meaning of Error:** Obstruction to movement detected because reed switch triggered in a high position; or the platen stopped above 1 inch from plate; or a motor fault occurs during the initial platen lower.

**Error Logging Type: Motor** (More details page 80)

**Troubleshooting steps:**

- Check for obstructions to platen movement: i.e. egg ring, hood, Ansul nozzles, spatula, scraper, grease shield on platen back, improper install of Teflon rod, platen shaft seal popped out of position . If obstruction suspected, clear obstruction and retry grill operation.
- Check actuator and motor control board with troubleshooting check list 4529505.

---

### **Error code: 23**

**Message on Screen:** ERROR

←WRONG SPEED CONTROL SOFTWARE

**Meaning of Error:** Front control has newer software, but Motor control does not. Need to update MCB software.

**Error Logging Type: Motor** (More details page 80)

**Troubleshooting steps:**

- Cycle power to confirm error.
- Flash MCB with newer software or replace MCB with a newer version with current software or replace front control with an older version.

## **ERROR CODES TROUBLESHOOTING GUIDE INFORMATION**

### **Error code: 25**

**Message on Screen:** ERROR

←FLIP RED PWR SWITCH OFF. CHECK POWER CORD AND RESTART

**Meaning of Error:** Communication errors are occurring between the front control and the motor control.

**Error Logging Type:** Motor (More details page 80)

**Troubleshooting steps:**

- Check communication cable and connections for damage, loose connectors, or loose wires. Swap communication cables between cook lanes to see if the error follows the cable.
- Swap one end of the communication cables between lanes to see if error follows the front control or the motor control (i.e. Connect the communication cable from the left lane front control to the centre lane motor control and connect the centre lane front control to left motor board ). If the error follows the front control, replace that control, if the error follows the motor board, then replace the motor board.

---

### **Error code: 26**

**Message on Screen:** ERROR

←FLIP RED PWR SWITCH OFF. CHECK POWER CORD AND RESTART

**Meaning of Error:** The front control cannot detect any communication from the motor control.

**Error Logging Type:** Motor (More details page 80)

**Troubleshooting steps:**

- Cycle power to confirm error
- Check communication cable and connections for damage, loose connectors, or loose wires. Swap communication cables between cook lanes to see if the error follows the cable.
- Confirm some LED's are lit on motor board. If some LED's are lit and this error is present, replace motor board.
- If no LED's are lit on motor board then measure power coming into the motor board. If no LED's and power present on input to motor board, the fuse is blown on motor board, replace motor board.
- If there is no power coming into the motor board then trace input power to find problem. Some possible causes could be: breaker turned off, power plug unplugged; loose wire in receptacle, plug or terminal block. Other causes could be damaged/loose wires in grill, blown contactor, or tripped platen over-temperature sensor. Note: if the platen goes over-temperature, the thermal sensor will trip interrupting the contactor coil circuit and causing this error.

## **ERROR CODES TROUBLESHOOTING GUIDE INFORMATION**

### **Error code: 27**

**Message on Screen:** ERROR

←FLIP RED PWR SWITCH OFF. CHECK POWER CORD AND RESTART

**Meaning of Error:** The front control cannot detect any communication from the motor control during a data write command to the motor board.

**Error Logging Type:** Motor (More details page 80)

#### **Troubleshooting steps:**

- Cycle power to confirm error
- Check communication cable and connections for damage, loose connectors, or loose wires. Swap communication cables between cook lanes to see if the error follows the cable.
- Confirm some LED's are lit on motor board. If some LED's are lit and this error is present, replace motor board.
- If no LED's are lit on motor board then measure power coming into the motor board. If no LED's and power present on input to motor board, the fuse is blown on motor board, replace motor board.
- If there is no power coming into the motor board then trace input power to find problem. Some possible causes could be: breaker turned off, power plug unplugged; loose wire in receptacle, plug or terminal block. Other causes could be damaged/loose wires in grill, blown contactor, or tripped platen over-temperature sensor. Note: if the platen goes over-temperature, the thermal sensor will trip interrupting the contactor coil circuit and causing this error.

---

### **Error code: 30**

**Message on Screen:** ERROR

←CALL FOR SERVICE - SURFACE DISABLED

**Meaning of Error:** The thermocouple sensor is out of range – grill plate, middle.

**Error Logging Type:** Temperature (More details page 82)

#### **Troubleshooting steps:**

- Check wiring and connectors at rear bottom of front control. Confirm wires are tight in connector and connector is plugged into control correctly. If wire trouble found, correct then retry control.
  - If no wire trouble found, replace plate middle thermocouple.
-

## **ERROR CODES TROUBLESHOOTING GUIDE INFORMATION**

### **Error code: 31**

**Message on Screen:** CALL SERVICE

←FLAT MODE ONLY - PRESS ENTER TO CONTINUE

**Meaning of Error:** thermocouple sensor is out of range – platen.

**Error Logging Type:** Temperature (More details page 82)

**Troubleshooting steps:**

- Check wiring and connectors at rear bottom of front control. Confirm wires are tight in connector and connector is plugged into control correctly. If wire trouble found, correct then retry control.
  - If no wire trouble found, replace plate platen thermocouple.
- 

### **Error code: 32**

**Message on Screen:** ERROR

←CALL FOR SERVICE - SURFACE DISABLED

**Meaning of Error:** The thermocouple sensor is out of range – grill plate, front.

**Error Logging Type:** Temperature (More details page 82)

**Troubleshooting steps:**

- Check wiring and connectors at rear bottom of front control. Confirm wires are tight in connector and connector is plugged into control correctly. If wire trouble found, correct then retry control.
  - If no wire trouble found, replace plate front thermocouple.
- 

### **Error code: 33**

**Message on Screen:** ERROR

←CALL FOR SERVICE - SURFACE DISABLED

**Meaning of Error:** The thermocouple sensor is out of range – grill plate, back.

**Error Logging Type:** Temperature (More details page 82)

**Troubleshooting steps:**

- Check wiring and connectors at rear bottom of front control. Confirm wires are tight in connector and connector is plugged into control correctly. If wire trouble found, correct then retry control.
  - If no wire trouble found, replace plate rear thermocouple.
-

## **ERROR CODES TROUBLESHOOTING GUIDE INFORMATION**

### **Error code: 34**

**Message on Screen:** ROOM TEMP LOW

← CANNOT USE GRILL UNTIL ROOM TEMP IS WARMER

**Meaning of Error:** The grill control is below minimum temperature to operate.

**Error Logging Type:** Temperature (More details page 82)

**Troubleshooting steps:**

- Raise room temperature above 32 degrees F / 0 degrees C.
  - If this error occurs when the grill control is clearly above this temperature, replace front panel control.
  - Note: a room temperature error will usually show on more than one control unless this is a control failure.
- 

### **Error code: 35**

**Message on Screen:** ROOM TEMP HIGH

← CANNOT USE GRILL UNTIL ROOM TEMP IS LOWER

**Meaning of Error:** The grill control is above the maximum operational temperature.

**Error Logging Type:** Temperature (More details page 82)

**Troubleshooting steps:**

- Lower room temperature to below 176 degrees F / 80 degrees C.
  - If this error occurs when the grill control is clearly below this temperature, replace front panel control.
  - Note: a room temperature error will usually show on more than one control unless this is a control failure.
- 

### **Error code: 36**

**Message on Screen:** NO IGNITION

← CHECK GAS SUPPLY & TURN CONTROL OFF/ON AND RETRY

**Meaning of Error:** No flame was sensed after 3 tries to ignite.

**Error Logging Type:** Temperature (More details page 82)

**Troubleshooting steps:**

- Confirm front control is configured to "GAS" for a gas grill, and to "ELECTRIC" for an electric grill.
  - Check gas supply valve(s) are turned on.
  - Check gas system using checklist 4529507.
-

## **ERROR CODES TROUBLESHOOTING GUIDE INFORMATION**

---

### **Error code: 37**

**Message on Screen:** ERROR

←CALL FOR SERVICE - SURFACE DISABLED

**Meaning of Error:** No rise in temperature measured after heater turned on. Plate, middle zone.

**Error Logging Type:** Temperature (More details page 82)

**Troubleshooting steps:**

- Check heater wiring and connectors, including grounds, neutrals and terminal blocks.
  - Verify power to heater. If no voltage at heater trace power back through SSR, SSR control circuit, contactors and power input until source of power interruption is found.
  - If the heater has power, verify the resistance of the heating element or the function of the gas burner. The gas system can be checked with Checklist 4529507. Replace any elements or burners that have failed.
- 

### **Error code: 38**

**Message on Screen:** CALL SERVICE

←FLAT MODE ONLY - PRESS ENTER TO CONTINUE

**Meaning of Error:** No rise in temperature measured after heater turned on; Platen.

**Error Logging Type:** Temperature (More details page 82)

**Troubleshooting steps:**

- Check heater wiring to and inside platen; including connectors. Check input power wiring including grounds, neutrals and terminal blocks.
  - Verify power to heater. If no voltage at heater trace power back through SSRs, SSR control circuit, contactors and power input until source of power interruption is found.
  - If the heater has power, verify the resistance of the heating elements in the platen, the three platen elements should be similar resistance. If a element has failed, replace the platen heater.
-

## **ERROR CODES TROUBLESHOOTING GUIDE INFORMATION**

### **Error code: 39**

**Message on Screen:** ERROR

←CALL FOR SERVICE - SURFACE DISABLED

**Meaning of Error:** No rise in temperature measured after heater turned on. Plate, front zone.

**Error Logging Type:** Temperature (More details page 82)

**Troubleshooting steps:**

- Check heater wiring and connectors, including grounds, neutrals and terminal blocks.
  - Verify power to heater. If no voltage at heater trace power back through SSR, SSR control circuit, contactors and power input until source of power interruption is found.
  - If the heater has power, verify the resistance of the heating element or the function of the gas burner. The gas system can be checked with Checklist 4529507. Replace any elements or burners that have failed.
- 

### **Error code: 40**

**Message on Screen:** ERROR

←CALL FOR SERVICE - SURFACE DISABLED

**Meaning of Error:** No rise in temperature measured after heater turned on. Plate, back zone.

**Error Logging Type:** Temperature (More details page 82)

**Troubleshooting steps:**

- Check heater wiring and connectors, including grounds, neutrals and terminal blocks.
  - Verify power to heater. If no voltage at heater trace power back through SSR, SSR control circuit, contactors and power input until source of power interruption is found.
  - If the heater has power, verify the resistance of the heating element or the function of the gas burner. The gas system can be checked with Checklist 4529507. Replace any elements or burners that have failed.
-

## **ERROR CODES TROUBLESHOOTING GUIDE INFORMATION**

---

### **Error code: 41**

**Message on Screen:** GRILL TOO HOT

ALLOW COOL DOWN

**Meaning of Error:** Thermocouple is reading a value over 465 degrees F ( 240 degrees C). All heaters are turned off. Griddle plate, center zone.

**Error Logging Type:** Temperature (More details page 82)

**Troubleshooting steps:**

- If the temperature continues to rise even after alarm, check SSR and replace SSR if failed.
  - Check temperature probe calibration, if probe cannot be calibrated, replace probe.
- 

### **Error code: 42**

**Message on Screen:** PLATEN TOO HOT

ALLOW COOL DOWN

**Meaning of Error:** Thermocouple is reading a value over 465 degrees F ( 240 degrees C). All heaters are turned off. Platen.

**Error Logging Type:** Temperature (More details page 82)

**Troubleshooting steps:**

- If the temperature continues to rise even after alarm, check SSR; replace SSR if failed.
  - Check temperature probe calibration, if probe cannot be calibrated, replace probe.
- 

### **Error code: 43**

**Message on Screen:** GRILL TOO HOT

ALLOW COOL DOWN

**Meaning of Error:** Thermocouple is reading a value over 465 degrees F ( 240 degrees C). All heaters are turned off. Griddle plate, front zone.

**Error Logging Type:** Temperature (More details page 82)

**Troubleshooting steps:**

- If the temperature continues to rise even after alarm, check SSR and replace SSR if failed.
  - Check temperature probe calibration, if probe cannot be calibrated, replace probe.
-

## **ERROR CODES TROUBLESHOOTING GUIDE INFORMATION**

---

### **Error code: 44**

**Message on Screen:** GRILL TOO HOT

ALLOW COOL DOWN

**Meaning of Error:** Thermocouple is reading a value over 465 degrees F ( 240 degrees C). All heaters are turned off. Griddle plate, back zone.

**Error Logging Type:** Temperature (More details page 82)

**Troubleshooting steps:**

- If the temperature continues to rise even after alarm, check SSR and replace SSR if failed.
  - If the SSR LED stays on after alarm sounds, replace front control.
  - Check temperature probe calibration, if probe cannot be calibrated, replace probe.
- 

### **Error code: 45-47**

**Message on Screen:** ERROR

←FLIP RED PWR SWITCH OFF/ON TO CLEAR ERROR OR CALL FOR SERVICE

**Meaning of Error:** Internal communication error within front controller.

**Error Logging Type:** Temperature (More details page 82)

**Troubleshooting steps:**

- Cycle main power to see if issue clears.
  - If not, replace front control.
- 

### **Error code: 48**

**Message on Screen:** PROD. NOT RECOG.

←CLEAN GRILL AND PRESS GREEN BUTTON TO CONTINUE

**Meaning of Error:** Measured product thickness value is not valid.

**Error Logging Type: Motor** (More details page 80)

**Troubleshooting steps:**

- Verify the grill has been calibrated recently, review calibration values in menu to ensure latest calibration value was not longer that 250 cycles ago. If longer, cycle power off for 20 seconds and allow grill to re-calibrate on start.
  - Review Product recognition troubleshooting section on page 27 of Operations Manual – 4521777.
-

## **ERROR CODES TROUBLESHOOTING GUIDE INFORMATION**

---

### **Error code: 49**

**Message on Screen:** None – This error is logged only.

**Meaning of Error:** Upper Limit Switch Missed. The travel limit was reached without hitting the switch.

**Error Logging Type:** Motor (More details page 80)

**Troubleshooting steps:**

- Check Upper Limit Switch (ULS) , wiring and connections for switch. Verify switch triggers LED on and off on Motor control board. If LED does not toggle, trace switch wiring and electrically check switch to find fault.
- 

### **Error code: 50**

**Message on Screen:** OK TO COOK

←CALL FOR SERVICE - PUSH GREEN BTN TO CONTINUE

**Meaning of Error:** Upper Limit Switch Failed, grill can continue using last switch position, but failed switch needs replacing.

**Error Logging Type:** Motor (More details page 80)

**Troubleshooting steps:**

- Verify if problem is with the Upper Limit switch or the switch wiring or connectors. Find fault and correct.
- 

### **Error code: 51**

**Message on Screen:** ERROR

←PUSH GREEN BUTTON TO RETRY CALIBRATION

**Meaning of Error:** Motor Control Board was reset – internal Motor control failure.

**Error Logging Type:** Motor (More details page 80)

**Troubleshooting steps:**

- Cycle power to see if control resets.
  - If issue continues, replace Motor control board.
-

## **ERROR CODES TROUBLESHOOTING GUIDE INFORMATION**

---

### **Error code: 52**

**Message on Screen:** CALL SERVICE

← FLAT MODE ONLY - PRESS ENTER TO CONTINUE

**Meaning of Error:** Suspected ULS or LLS problem. Suspected platen positioning error.

**Error Logging Type:** Motor (More details page 80)

**Troubleshooting steps:**

- Verify the grill has been calibrated recently, review calibration values in menu to ensure latest calibration value was not longer that 250 cycles ago. If longer, cycle power off for 20 seconds and allow grill to re-calibrate on start.
  - Run gap drift check: 4529505. If fails, replace Actuator (Part Number 4530036)
  - Check Upper and Lower limit switches are tight and wired in properly. Look for loose wires or connectors. Check switch function with electrical continuity meter.
- 

### **Error code: 53**

**Message on Screen:** None, this error is logged only.

**Meaning of Error:** Suspected ULS or LLS problem. Suspected platen positioning error.

**Error Logging Type:** Motor (More details page 80)

**Troubleshooting steps:**

- Verify the grill has been calibrated recently, review calibration values in menu to ensure latest calibration value was not longer that 250 cycles ago. If longer, cycle power off for 20 seconds and allow grill to re-calibrate on start.
  - Run gap drift check: 4529505. If fails, replace Actuator (Part Number 4530036)
  - Check Upper and Lower limit switches are tight and wired in properly. Look for loose wires or connectors. Check switch function with electrical continuity meter.
- 

### **Error code: 54**

**Message on Screen:** WRONG GRILL TYPE

← GAS GRILL SET TO ELECTRIC - TURN UNIT OFF, CHANGE GRILL TYPE THEN CYCLE MAIN POWER

**Meaning of Error:** Gas grill has been configured as an electric grill.

**Error Logging Type:** Temperature (More details page 82)

**Troubleshooting steps:**

- Enter Program Menu, Configure submenu. Change Grill type from Electric to Gas.
-

## **ERROR CODES TROUBLESHOOTING GUIDE INFORMATION**

### **Error code: 55**

**Message on Screen:** ERROR

← PUSH GREEN BUTTON TO RETRY CALIBRATION

**Meaning of Error:** During CALIBRATION, the platen is raised and the ULS doesn't close or open when expected.

**Error Logging Type:** Motor (More details page 80)

**Troubleshooting steps:**

- Check Upper Limit Switch, switch wiring and connectors.
- 

### **Error code: 56**

**Message on Screen:** None, this error is logged only and is recorded only if the motor is not moving.

**Meaning of Error:** The front control cannot detect any communication from the motor control.

**Error Logging Type:** Motor (More details page 80)

**Troubleshooting steps:**

- Cycle power to confirm error
  - Check communication cable and connections for damage, loose connectors, or loose wires. Swap communication cables between cook lanes to see if the error follows the cable.
  - Confirm some LED's are lit on motor board. If some LED's are lit and this error is present, replace motor board.
  - If no LED's are lit on motor board then measure power coming into the motor board. If no LED's and power present on input to motor board, the fuse is blown on motor board, replace motor board.
  - If there is no power coming into the motor board then trace input power to find problem. Some possible causes could be: breaker turned off, power plug unplugged; loose wire in receptacle, plug or terminal block. Other causes could be damaged/loose wires in grill, blown contactor, or tripped platen over-temperature sensor. Note: if the platen goes over-temperature, the thermal sensor will trip interrupting the contactor coil circuit and causing this error.
-

## **ERROR CODES TROUBLESHOOTING GUIDE INFORMATION**

---

### **Error code: 123**

**Message on Screen:** None, this error is logged only.

**Meaning of Error:** User history log corrupt

**Error Logging Type:** Temperature (More details page 82)

**Troubleshooting steps:**

- Replace front panel control
- 

### **Error code: 124**

**Message on Screen:** None, this error is logged only.

**Meaning of Error:** User history log has been deleted

**Error Logging Type:** Temperature (More details page 82)

**Troubleshooting steps:**

- None required, someone has deleted the error log history.
- 

### **Error code: 125**

**Message on Screen:** None, this error is logged only.

**Meaning of Error:** History log has been deleted

**Error Logging Type:** Temperature (More details page 82)

**Troubleshooting steps:**

- None required, error log history has been deleted.
- 

### **Error code: 126**

**Message on Screen:** None, this error is logged only.

**Meaning of Error:** History log corrupt

**Error Logging Type:** Temperature (More details page 82)

**Troubleshooting steps:**

- Replace front panel control
-

# GRILL EXTERIOR, ALL MODELS

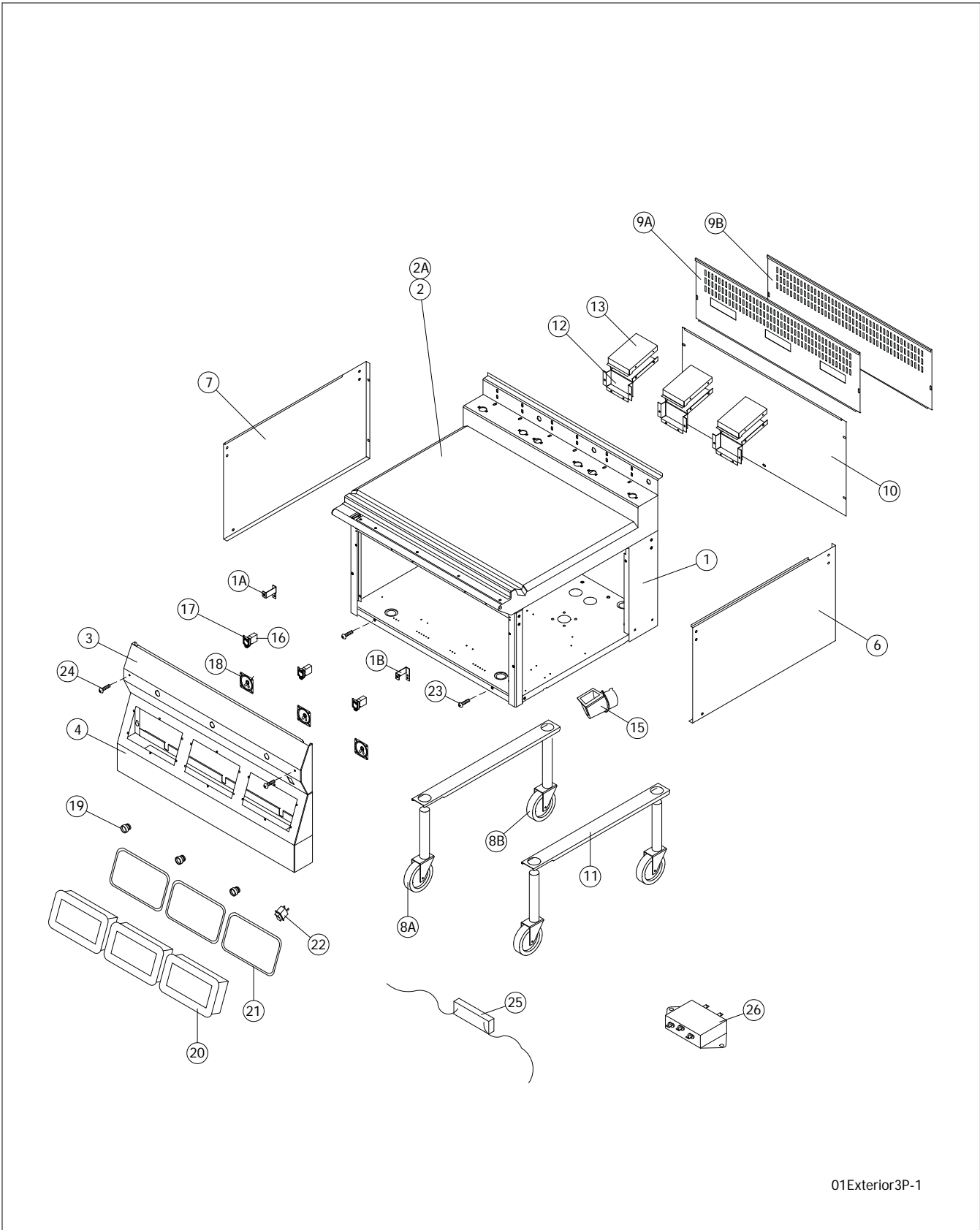

01Exterior3P-1

## GRILL EXTERIOR, ALL MODELS

ITEM #	PART #	DESCRIPTION	QTY.	CRITICAL
1	4530090	STD BODY BASE,WA	1	
1A	4526598	FRONT PANEL BRACKET, RT	1	
1B	4526597	FRONT PANEL BRACKET, LT	1	
2	<a href="#">4522707</a>	PLATE WA, GAS	1	
2A	<a href="#">4522653</a>	PLATE WA, ELECTRIC	1	
3	<a href="#">4522560</a>	FRONT PANEL, UPPER (PRC)	1	
4	<a href="#">4530092</a>	FRONT PANEL,LOWER 3P	1	
6	<a href="#">4529972</a>	SIDE, RT STD	1	
7	<a href="#">4529973</a>	SIDE, LT STD	1	
8A	<a href="#">4517563</a>	5" FRONT SWIVEL CASTER W/BRAKE	2	
8B	<a href="#">1792003</a>	5" REAR SWIVEL CASTER	2	
9A	4529974	BACK, UPPER (GAS)	1	
9B	<a href="#">4529977</a>	BACK, UPPER (ELECTRIC)	1	
10	<a href="#">4529975</a>	SPLIT BACK, BOTTOM	1	
11	<a href="#">4523352</a>	LEG BRACE LOCKING BRACKET	2	
12	<a href="#">4525261</a>	FLUE BOTTOM, GAS	3	
13	<a href="#">4525262</a>	FLUE TOP, GAS	3	
14	<a href="#">1808302</a>	TOWEL BAR	1	
15	<a href="#">1866501</a>	MENNEKES 7-WAY SOCKET	1	
16	<a href="#">1859606</a>	CONTACT BLOCK	3	
17	<a href="#">1859607</a>	MOUNTING LATCH	3	
18	<a href="#">4523482</a>	SPEAKER, 4 WATTS SMT	3	
19	<a href="#">1859605</a>	CANCEL PUSH BUTTON, GREEN	3	C
20	<a href="#">4531045</a>	MAIN CONTROLLER	3	C
21	<a href="#">1872601</a>	GORE-TEX SEAL, .125"X.020"X2.85'	3	C
NS	???	CONTROLLER+SEAL; (1) <a href="#">4530447</a> + (1) <a href="#">1872601</a>		C
22	<a href="#">1872404</a>	POWER SWITCH, MAIN 120-240V	1	C
23	<a href="#">F298</a>	BOLT 10-24X3/8"		
24	<a href="#">1935903</a>	MSCR, TRUSS HEAD 10-24X3/4 UNC SS		
25	<a href="#">4526941</a>	EMI FILTER LONWORKS OPTION	3	
26	<a href="#">4526943</a>	EMI LINE - LINE FILTER, LONWORKS OPTION	3	

# GRILL ELEMENT, ELECTRIC MODELS

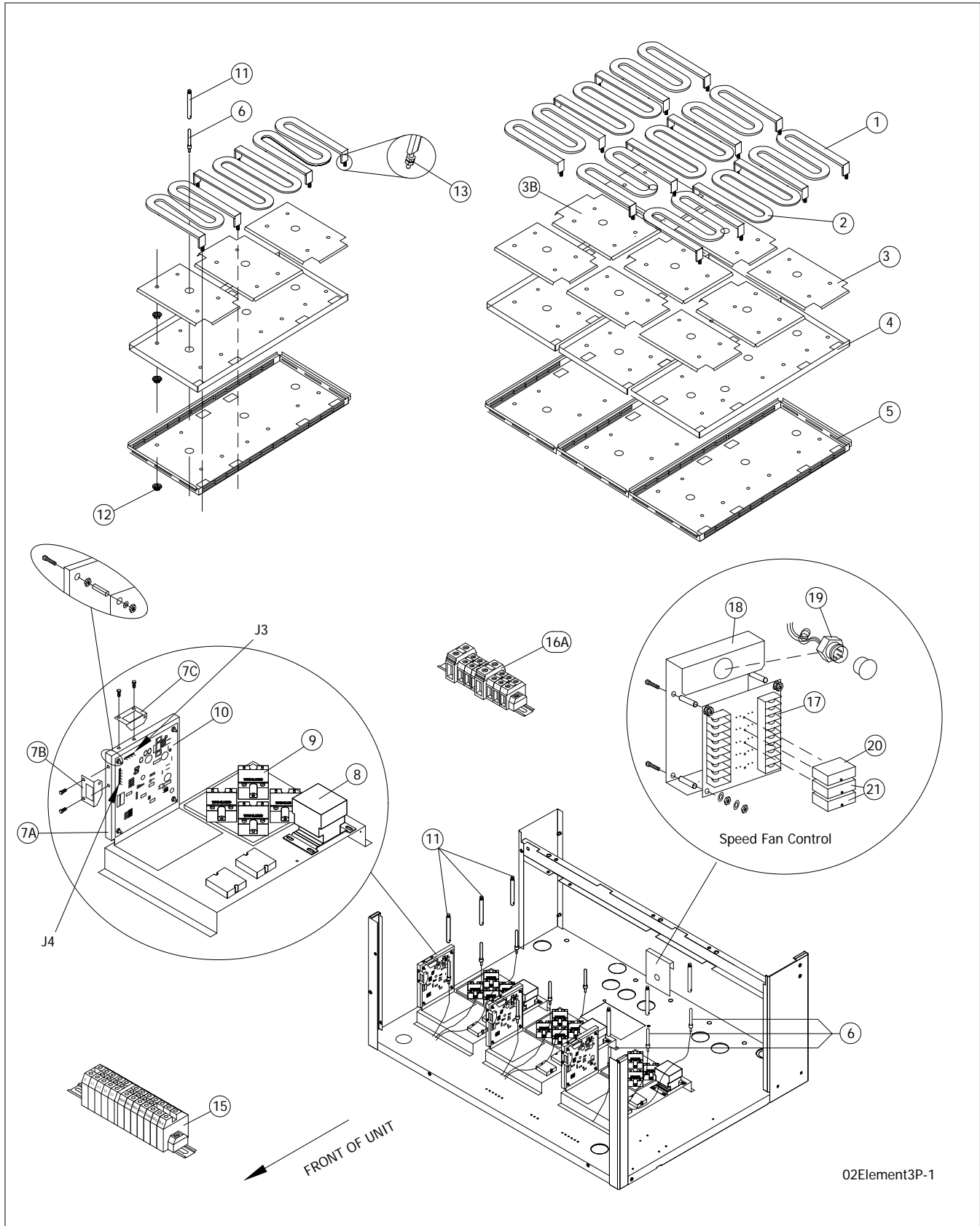

02Element3P-1

## GRILL ELEMENT, ELECTRIC MODELS

ITEM#	PART#	DESCRIPTION	QUANTITY PER		CRITI- CAL
			GRILL	ZONE.	
1	4521310	ELEMENT, OUTER, 208V 1300W	6	3	
	4521720	ELEMENT, OUTER, 220V 1300W	6	3	
	4521312	ELEMENT, OUTER, 230V 1300W	6	3	
	4521721	ELEMENT, OUTER, 240V 1300W	6	3	
2	4521309	ELEMENT, INNER 208V 1700W	3	1	
	4521718	ELEMENT, INNER 220V 1700W	3	1	
	4521311	ELEMENT, INNER 230V 1700W	3	1	
	4521719	ELEMENT, INNER 240V 1700W	3	1	
3A	4520682	ELEMENT CLAMP, OUTER	6	3	
3B	4520681	ELEMENT CLAMP, INNER	3	1	
4	4524029	ELEMENT PAN, UPPER	1	*	
5	4524030	ELEMENT PAN, LOWER	1	*	
6	4521318	THERMOCOUPLE; GRILL PLATE ELECTIC	9	3	C
7A	4521389	MOTOR SPEED CONTROL BRACKET	3	1	
7B	4529690	CLIP - 4 PIN	3	1	
7C	4529691	CLIP - 6 PIN	3	1	
8	1637001	CONTACTOR 120V	3	1	C
	1637002	CONTACTOR 240V	3	1	C
9	4524082	SOLID STATE RELAY	15	5	C
10	4530944	MOTOR SPEED BOARD BLK2	3	1	C
11	1859404	BAYONNET ADAPTER	9	3	C
12	4518173	PAL NUT 5/16-18			
13	4518666	NUT TWIN WHIZ 10-32 LOCK			
14*	4521896	COMM CABLE (SEE WIRING HARNESS SECTION)	3	1	C
15	4522188	TERMINAL BLOCK (CONTROL COMPONENTS)	1	1	
16A	4517674	TERMINAL BLOCK (3PHASE CONNECTION, ELEC GRILL)	1	1	
16B*	4525397	TERMINAL BLOCK (3PHASE CONNECTION, GAS GRILL)	1	1	
16C*	4529170	MAIN TERMINAL BLOCK, CE, MCDS, 70 AMP, ENN123			
17	4522117	2-SPD FAN RELAY BOARD W SPACERS	1	1	
18	4522120	2-SPD FAN RELAY MOUNTING BRACKET	1	1	
19	4528558	STRAIGHT RECEPTACLE			
20	4522118	BLACK INPUT/OUTPUT MODULE			
21	4522279	RED INPUT/OUTPUT MODULE			

\* NOT ILLUSTRATED ON DRAWING



## GAS BURNER, GAS MODELS

ITEM#	PART#	DESCRIPTION	QUANTITY PER.		CRITICAL
			GRILL	PLATEN	
1	4523394	BURNER ASSY NATURAL	3	1	
	4523395	BURNER ASSY LP	3	1	
	4523396	BURNER ASSY CE NAT	3	1	
	4523397	BURNER ASSY CE LP	3	1	
2	4525845	BLOWER MOTOR 120VAC	3	1	
	4526139	BLOWER MOTOR 230VAC	3	1	
3	4524066	FLAME SENSOR	3	1	
4	4525537	IGNITER	3	1	
5	1864803	IGNITION CABLE	3	1	
9	1864701	GAS VALVE (NAT/LP) 120VAC	3	1	
	4525846	GAS VALVE CE (NAT/LP) 230VAC	3	1	
10	4516116	HEAT SINK	3	1	
11	4516988	SOLID STATE RELAY W LED LIGHT	6	2	
12	1637001	CONTACTOR 120V COIL	3	1	
	1637002	CONTACTOR 240V COIL	3	1	
13	4529686	BRKT - MOTOR SPD W/CLIPS	3	1	
14	1864901	IGNITION MODULE 120V	3	1	
	4522571	IGNITION MODULE PACTROL 230V CE	3	1	
15	4517392	AIR PRESSURE SWITCH	3	1	
16	4530451	MOTOR SPEED BOARD BLK2	3	1	
17	3084200	BAYONET ADAPTOR EXTENSION	3	1	
18	4521710	THERMOCOUPLE, GRILL PLATE (GAS GRILLS)	3	1	
19	1859404	BAYONET ADAPTOR (GRILL PLATE)	3	1	
20	1853301	FINISH HEX NUT 1-1/2 X 12	3	1	
22	4524198	FITTING, 90DEG, ELBOW - 3/8" NPT X 5/18"-18, BRASS	3	1	
25	4517396	FLUE BOX, INNER	3	1	
26	4517397	FLUE BOX, OUTER	3	1	
27	4521896	COMM CABLE	3	1	
28	4521678	GAS TUBE CTR	1	1	
29	4521679	GAS TUBE LT	1	1	
30	4521677	GAS TUBE RT	1	1	
31	4517394	GAS INLET MANIFOLD	1	*	
32	8002106	SMSCR-TH PHIL-A #10 X1/2 STL SP			
33	4522188	TERMINAL BLOCK (CONTROL COMPONENTS)			
34	4525397	TERMINAL BLOCK (3PHASE CONNECTION, GAS GRILL)			
35	1838701	PLATEN LEVELING TOOL			

# UPPER PLATEN ASSEMBLY, ALL MODELS

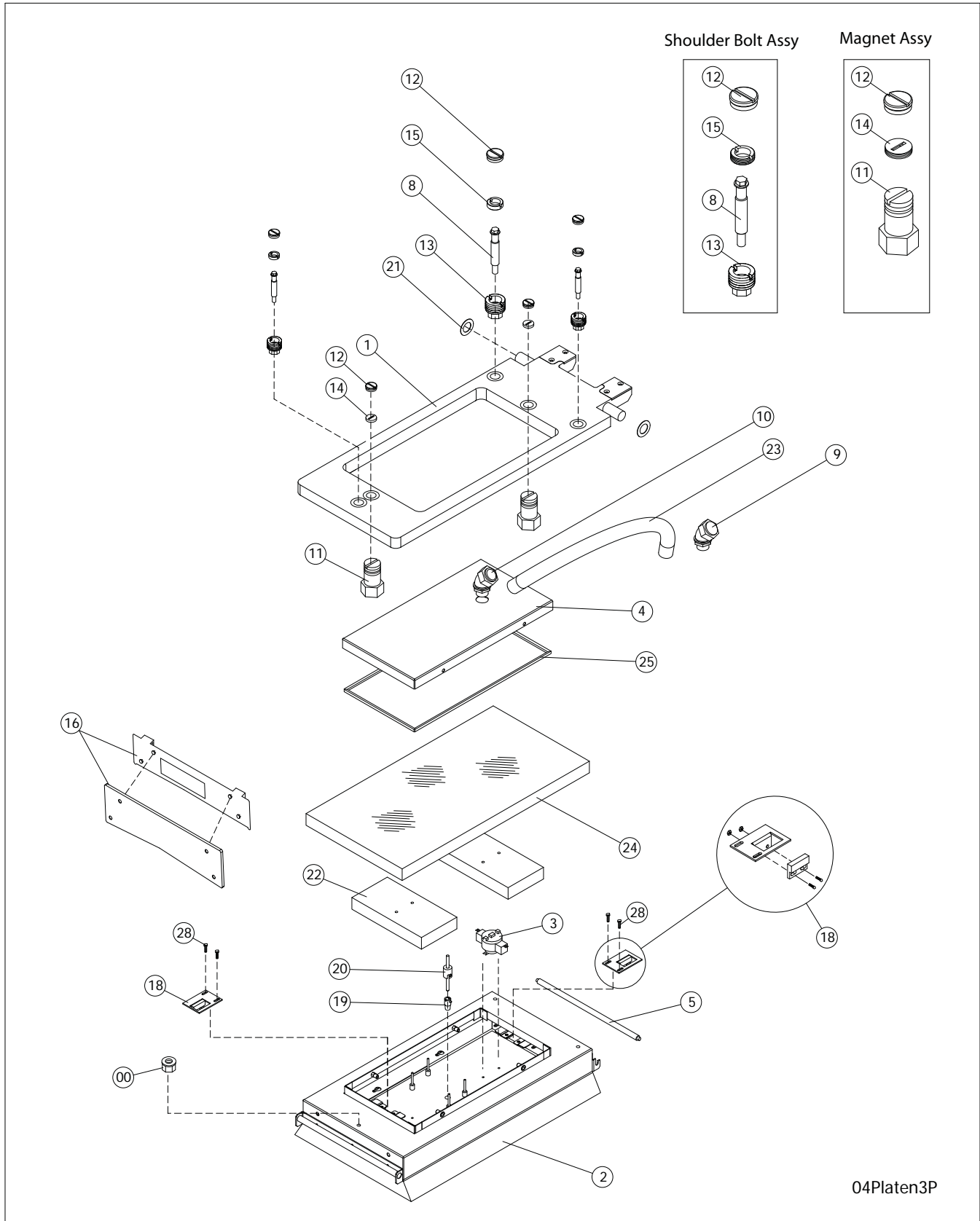

## UPPER PLATEN ASSEMBLY, ALL MODELS

ITEM #	PART #	DESCRIPTION	QUANTITY.	
			GRILL	PLATEN
1	4521293	PLATEN ARM ASSEMBLY	3	1
2	4530005	PLATEN ASSEMBLY; 208V	3	1
	4530006	PLATEN ASSEMBLY; 220V	3	1
	4530007	PLATEN ASSEMBLY; 230V	3	1
	4530008	PLATEN ASSEMBLY; 240V	3	1
3	1781301	HIGH LIMIT (AUTO RESET)	3	1
	1866601	HIGH LIMIT (MANUAL RESET) *EXPORT ONLY	3	1
4	4530209	3P PLATEN LID	3	1
5	4521355	TEFLON BAR, REAR	3	1
8	4524062	SHOULDER BOLT, PLATEN	6	3
9	4521709	1/2IN X 90 DEG LIQUID TIGHT FITTING	3	1
10	1854504	1/2IN X 45 DEG. LIQUID TIGHT FITTING	3	1
11	4529538	MAGNET HOLDER ASSEMBLY	6	2
12	1859102	PLATEN ADJUSTER CAP	15	5
13	4529543	9/16 HEX PLATEN ADJUSTER NUT	9	3
14	4530206	MAGNET HOUSING LOCKNUT	6	2
15	4521793	LOCK NUT	9	3
16	CK4530053	VAPOUR SHIELD KIT	3	1
18	4530001	REED SWITCH ASSEMBLY	6	2
19	1859402	PLATEN BAYONET ADAPTOR	3	1
20	4521711	THERMOCOUPLE	3	1
21	1855903	TEFLON WASHER CARRIAGE SHAFT	6	2
22	4522054	PLATEN WEIGHT	6	2
23	1854403	ATX-11 CONDUIT BLACK	3	1
24	0010000FG	1IN FIBERGLASS INSULATION #SGR-6	3	1
25	4529435	GASKET, LID 3P	3	1
28	4522260	ALLEN HEAD MOUNTING SCREW - 6-32 X 3/8"		



## PLATEN LIFTING MECHANISM, ALL MODELS

ITEM #	PART #	DESCRIPTION	QTY.
1	4523868	ACTUATOR FRAME, PAINTED	3
2	1858199	PILOW BLOCK ASSEMBLY	12
3	1858001	ACTUATOR CLEVIS MOUNT	3
4	4530036	LINEAR ACTUATOR	3
5	1857601	LIMIT SWITCH BRACKET	6
6	1855601	STOP LIMIT SWITCH,	6
7	4521654	SWITCH BRACKET, RUNAWAY	3
8	1855604	LIMIT SWITCH (KILL)	3
9	4522318	CROSS MEMBER, PAINTED	3
10	4523364	ARM CARRIAGE, SHAFT ASSEMBLY (RT)	3
11	4522540	ARM CARRIAGE, SHAFT ASSEMBLY (LT)	3
12	4518788	ACTUATOR CROSS MEMBER CLAMP, PAINTED	6
13	4523856	ACTUATOR FRAME BRACE, PAINTED	3
14	1857703	SEAL CAP	6
15	4526311	SHAFT SEAL WIPER, BLACK SOLID	6
15	4526312	SHAFT SEAL WIPER, BLACK W/ BLUE DOT SPLIT	-
16	1874201	SEAL CAP O-RING	6
17	8003437	SCREW, HXSLT #8-32 X 1	12
18	1874301	#8-32 O-RING	12
19	1863396	SEAL CAP MOUNTING BRKT, S/W LT (PAINTED)	3
20	1863397	SEAL CAP MOUNTING BRKT, S/W RT (PAINTED)	3
21	4522600	HI-LIMIT BRACKET, JAPAN	3
22	4521294	ARM PIVOT BLOCK	6
23	1854902	CAM FOLLOWER W/SHAFT	6
24	1854903	JAM NUT	6
25	4521709	1/2IN CONNECTOR, 90DEG.	3

# WIRING HARNESSES, ALL MODELS

Part#: **1859803**  
**Main Power Switch**  
 (Molex Plug to Terminal Block)

**SS DETAIL**

	2	1
	2	1
6	5	4
6	5	4

1=ORG    5=BLK  
 2=BRN    6=WHT  
 4=RED

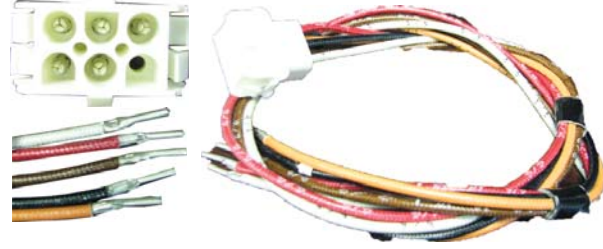

Part#: **4527095**  
**Upper Platen Harness**  
 (Molex Plug to Upper Platen)

**P2 DETAIL**

9	8	7
3	2	1
6	5	4
	51	50

7=BLK    50=BRN  
 8=RED    51=BRN  
 9=WHT    88=GRN



**EXPORT ONLY**

Part#: **1859814**  
**Upper Platen Harness**  
 (Molex Plug to Upper Platen)

**P2 DETAIL**

9	8	7
3	2	1
6	5	4
10	51	50



Part#: **1859808**  
**Main Heater Harness**  
**Electric Grills Models**  
 (Molex Plug to Grill Plate Heating Elements)

**P1 DETAIL**

L3	L2	L1
3	2	1
6	5	4
3	2	1

L1, L2, L3=BLK  
 1, 2, 3=RED

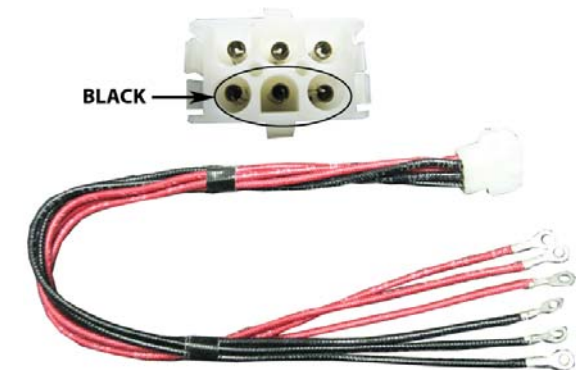

# WIRING HARNESSES, ALL MODELS

Part#: **1859813**  
 Main Heater Harness  
 Electric Grill  
 (Molex Plug to Grill Plate Heating Elements)

EXPORT ONLY

S1 DETAIL

1,2,3=BLK  
 11,12,13=WHT



Part#: **1859833**  
 Main Power Switch Harness  
 (Molex Plug to Power Switch)

P5 DETAIL

1=ORG 5=BLK  
 2,3=BRN 6=WHT  
 4=RED

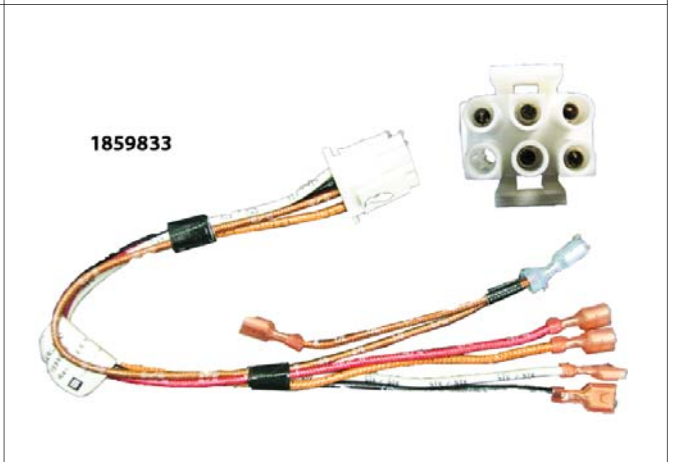

Part#: **4521950**  
 Pushbutton Harness

35=BLK  
 25=WHT

S4 DETAIL

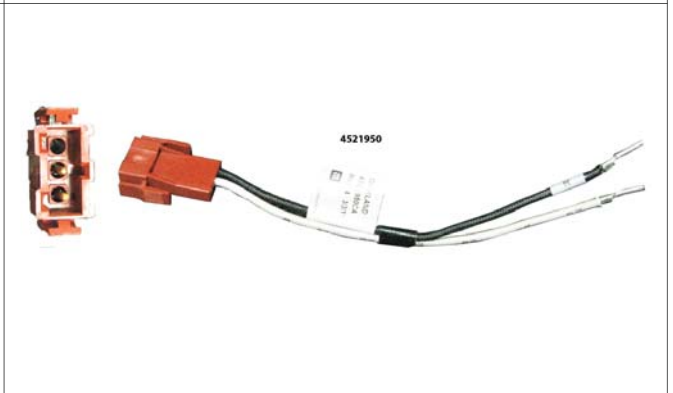

Part#: **4522630**  
 Relay Harness  
 (Grill Plate Molex Plug to SSR's Contactor)

L1,L2,L3=BLK  
 1,2,3=RED  
 21,22,23=BLK

P1 DETAIL



# WIRING HARNESSES, ALL MODELS

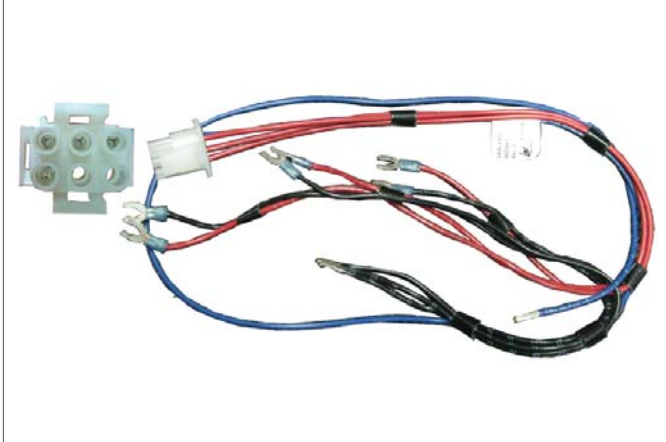
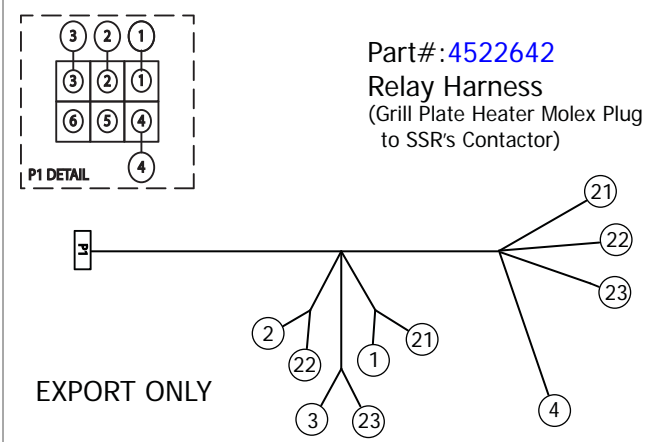
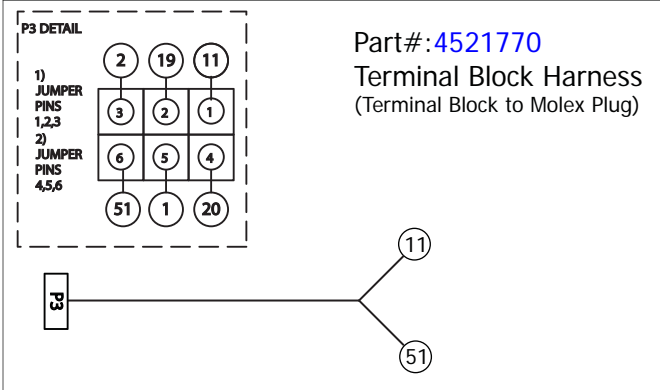
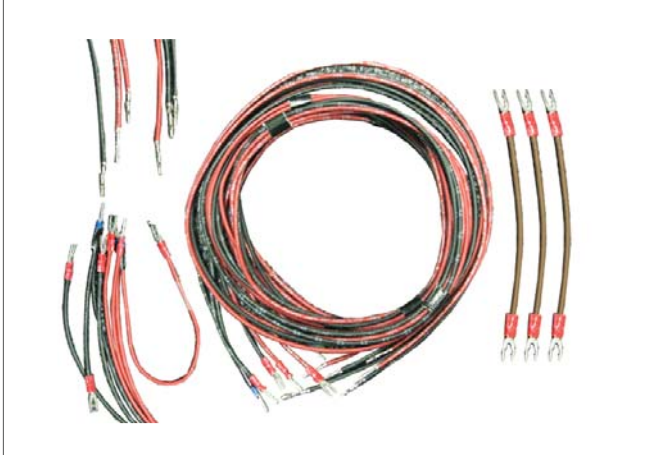
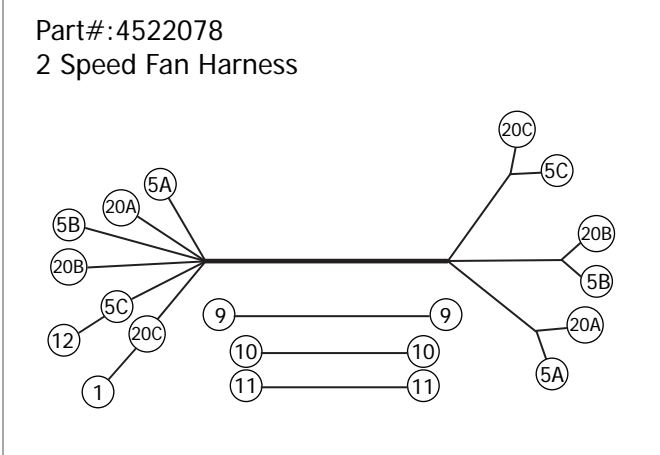
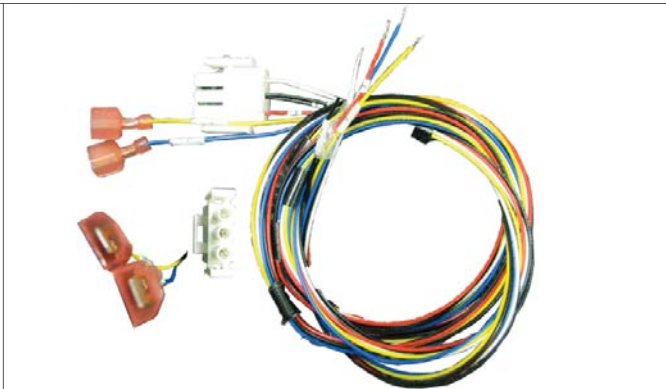
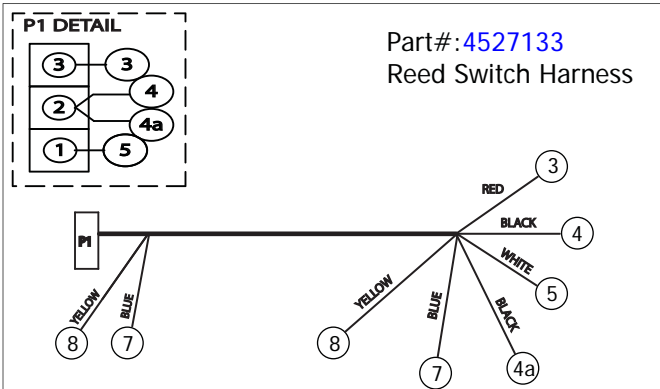

# WIRING HARNESSES, ALL MODELS

Part#: **4521811**

**Mennekes Harness**

(Mennekes socket to contactor terminal block)

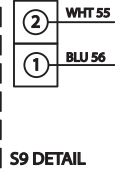
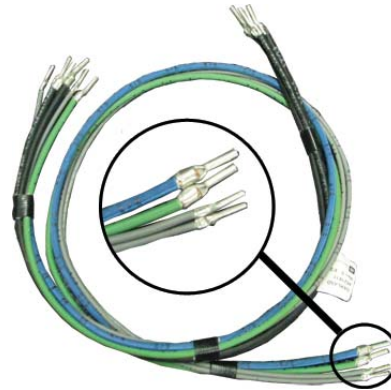
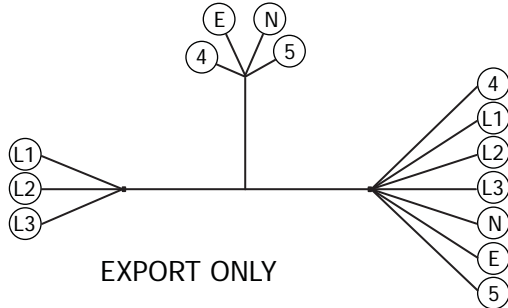

Part#: **4521898**

**Ignition Harness**

(Ignition module to Gas valve Molex plug)

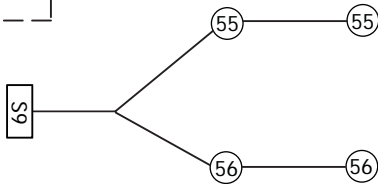

Part#: **4521896**

**RS 485 Cable**

(Motor speed control to control board)

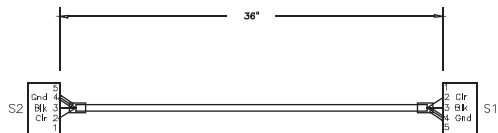

4521896 (RS 485 CABLE)

# WIRING HARNESSES, ALL MODELS

## W/Harness Kit

Part #: **4530522**

For use with these 3 platen grills

Model	Electrical Specification
MWG3W	3P WYE & DELTA Gas
MWE3W/S	3P WYE Elec (except Brazil, China & H.K.)

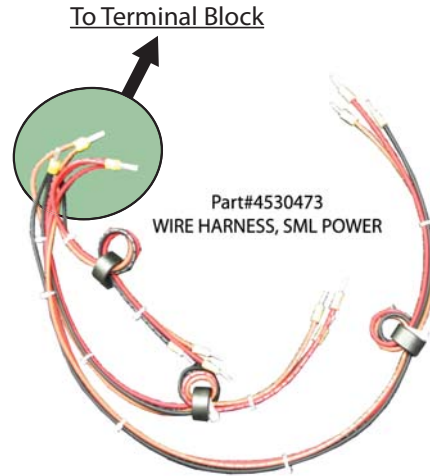
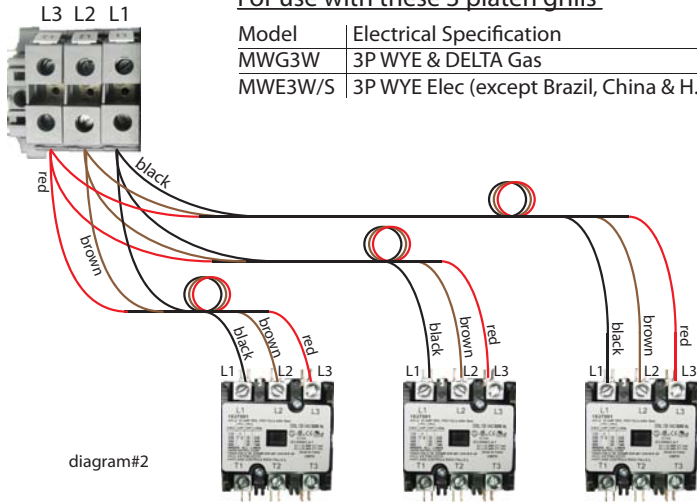

## W/Harness Kit

Part #: **4530523**

For use with these 3 platen grills

Models	Electrical Specification
MWE3W	3P DELTA Electric
MWE3W/S	3P WYE Electric for Brazil, China & H.K.

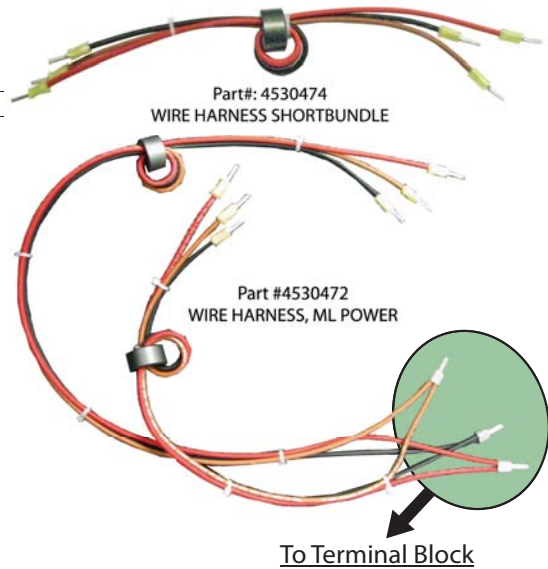
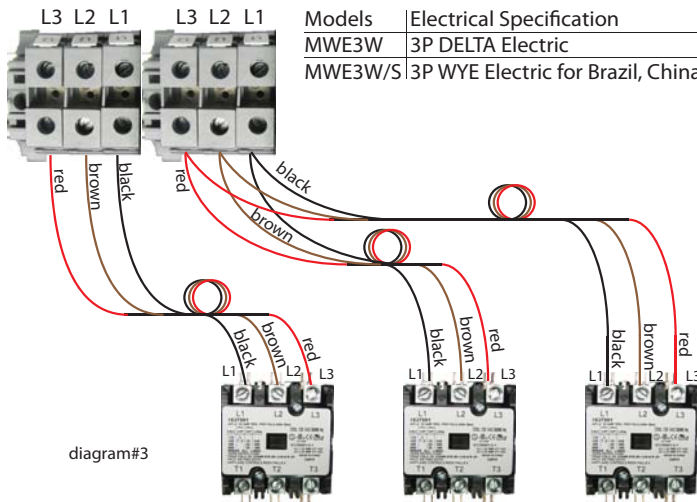

# WIRING DIAGRAM, MWE3W/S 200-240V - DELTA 50/60

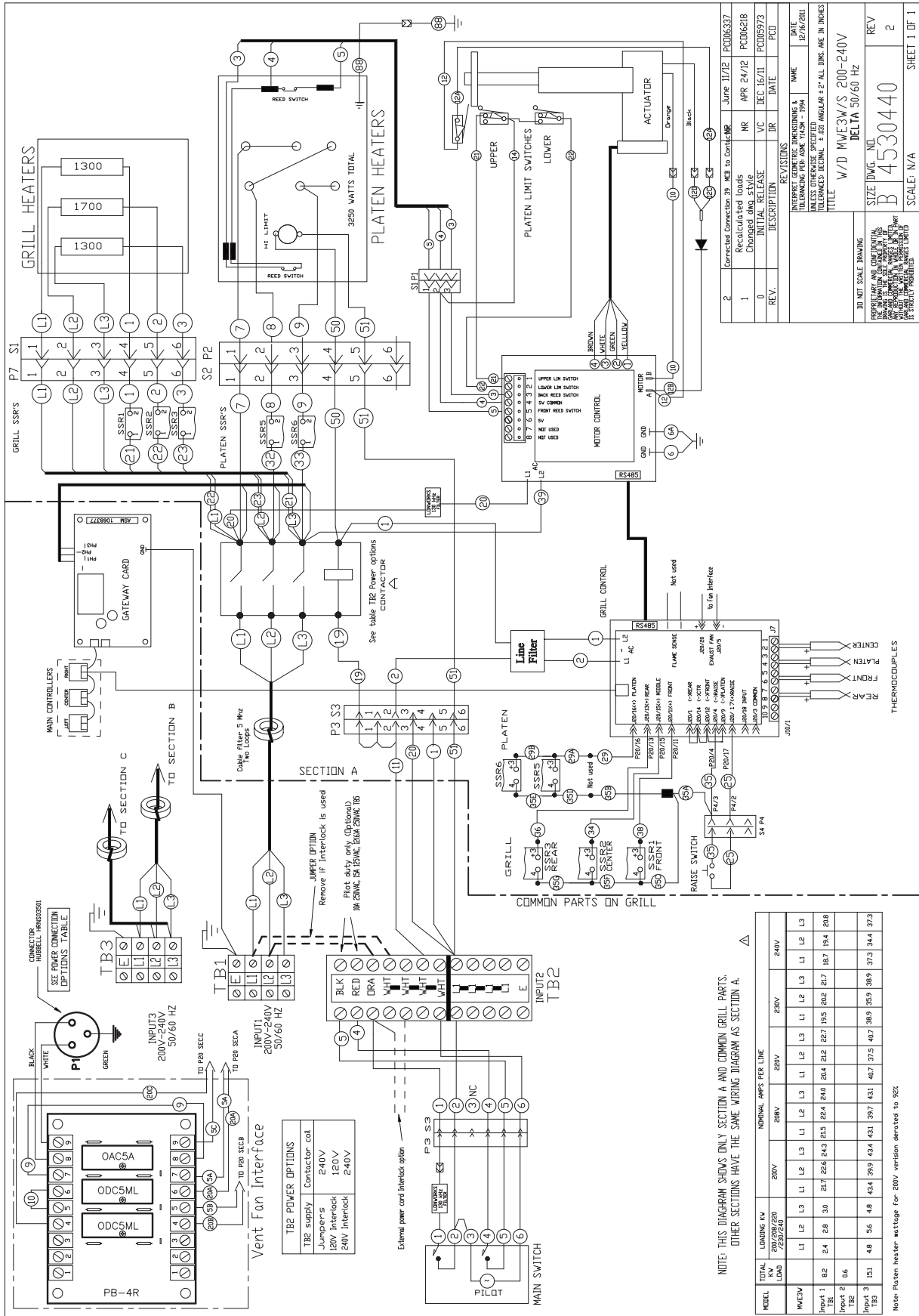

# WIRING DIAGRAM, MWE3W/S 380/400/415V, WYE 50/60Hz

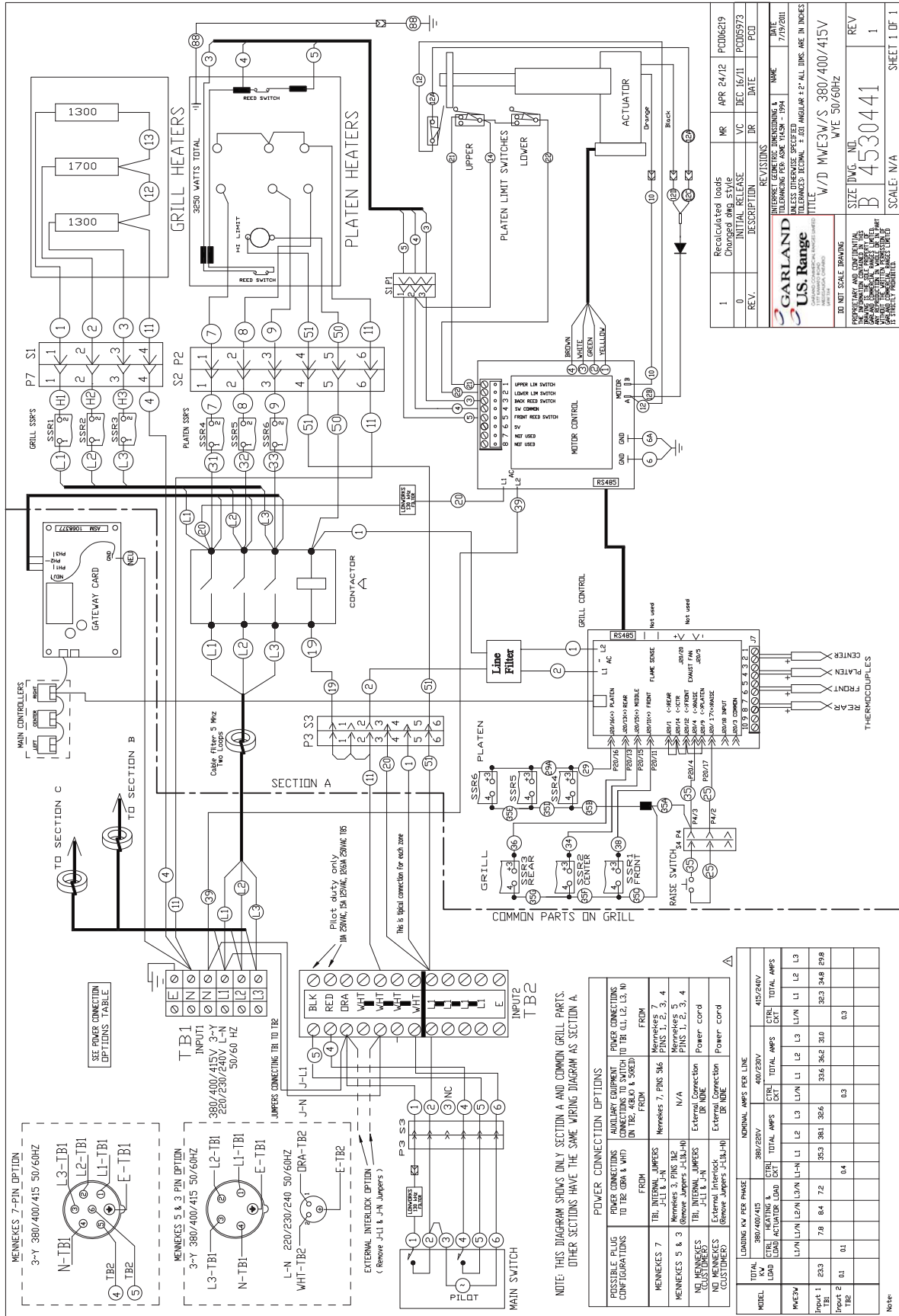

NOTE: THIS DIAGRAM SHOWS ONLY SECTION A AND COMMON GRILL PARTS. OTHER SECTIONS HAVE THE SAME WIRING DIAGRAM AS SECTION A.

**POWER CONNECTION OPTIONS**

POSSIBLE PLUG CONFIGURATIONS	AUXILIARY EQUIPMENT CONNECTIONS TO SWITCH (ON TB2, 240 & 320V)	POWER CONNECTIONS TO TB1 (L1, L2, L3, N)	FROM
MENNEKES 7	External Interlock (External Jumpers J-L1 & J-N)	PN1S 1, 2, 3, 4	Mennekes 7
MENNEKES 5 & 3	External Interlock (External Jumpers J-L1-H)	PN1S 1, 2, 3, 4	Mennekes 5
NO MENNEKES	External Interlock (External Jumpers J-L1-H)	Power cord	Power cord

MODEL	LOADING KV PER PHASE		NOMINAL AMPS PER LINE		415/240V	
	HEATING & ACTUATOR LOAD	CTRL	TOTAL AMPS	CTRL	TOTAL AMPS	CTRL
MWE3W	L1/L1/N, L2/L2/N, L3/L3/N	L1, L2, L3	35.3	36.2	31.0	31.8
Input 1	7.8	8.4	7.2	35.3	36.1	32.6
Input 2	0.1	0.4	0.4	0.3	0.3	0.3



# WIRING DIAGRAM, MWG3W 380/100/415V, WYE 50/60 Hz

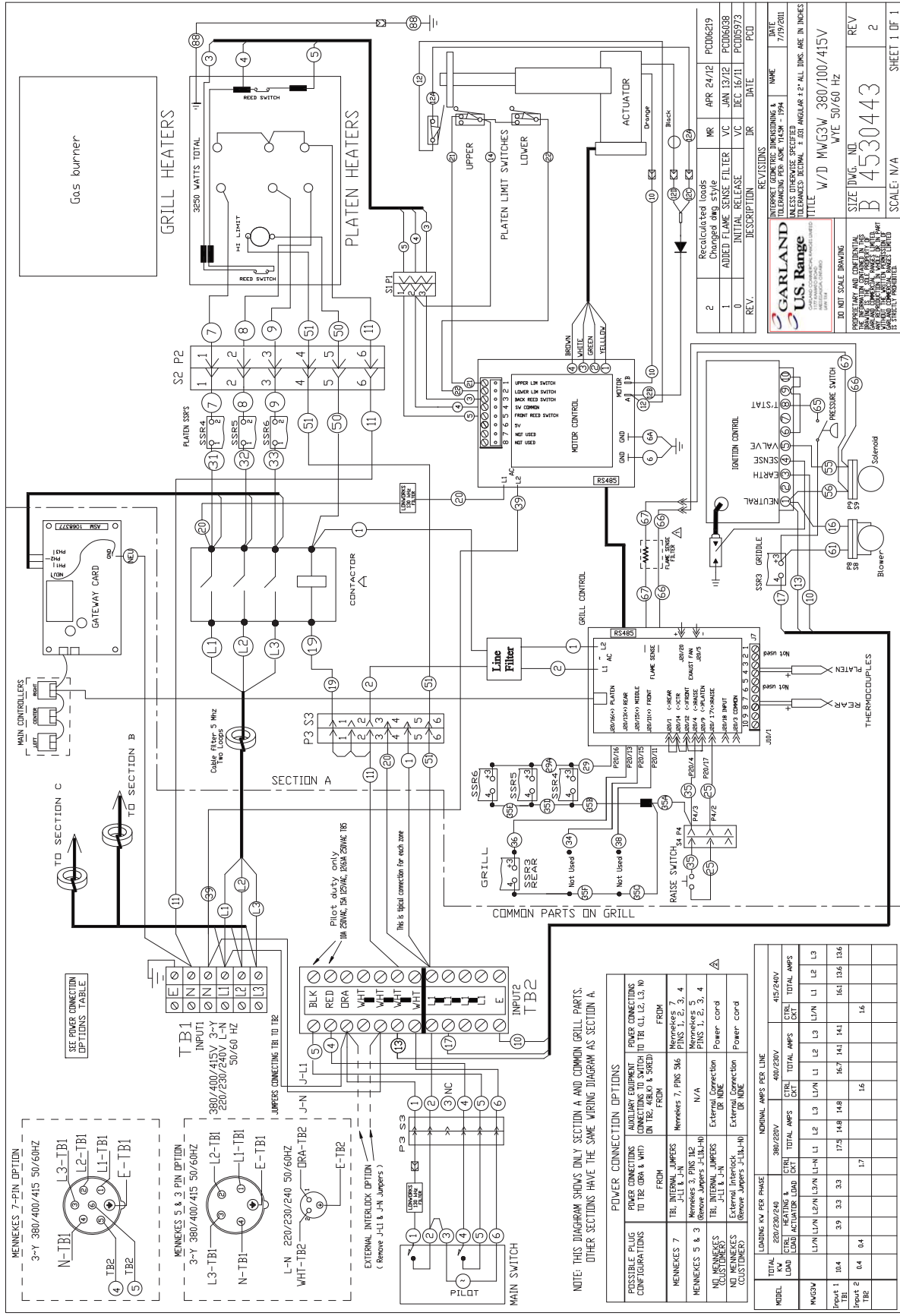

REV.	DESCRIPTION	DATE	BY
2	Revised Loads	APR 24/12	PCDD4219
1	Changed 600 style	JAN 13/12	PCDD6938
0	INITIAL RELEASE	DEC 16/11	PCDD5973

DATE	7/19/2011
NAME	
INTERPRET GENERAL DIMENSIONS & TOLERANCES PER ASME Y14.5M - 1994	
UNLESS OTHERWISE SPECIFIED DIMENSIONS ARE IN INCHES	
TITLE	W/D MWG3W 380/100/415V
SIZE DWG. NO.	B 4530443
REV	2
SCALE	N/A
SHEET	1 OF 1

NOTE: THIS DIAGRAM SHOWS ONLY SECTION A AND COMMON GRILL PARTS. OTHER SECTIONS HAVE THE SAME WIRING DIAGRAM AS SECTION A.

POWER CONNECTION OPTIONS	FROM	TO
PROPER PLUG CONFIGURATIONS	TO TB2 (GRN & WHT)	TO TB1 (L1, L2, L3, W)
MEMNEKES 7	FROM	MEMNEKES 7
MEMNEKES 5 & 3	FROM	MEMNEKES 5 & 3
NO MEMNEKES (CUSTOMER)	FROM	External Connection (IP NONE)
NO MEMNEKES (CUSTOMER)	FROM	External Connection (IP NONE)

MODEL	LOADING KW PER PHASE		NORMAL AMPS PER LINE		415/240V	
	CTR	ACTUATOR LOAD	CTR	TOTAL AMPS	CTR	TOTAL AMPS
MWG3W	L1/L1	L2/L2	L3/L3	L1/L1	L2/L2	L3/L3
Part 1	10.4	3.9	3.3	17.5	14.8	16.7
Part 2	0.4	0.4	0.4	1.7	1.6	1.6

# WIRING DIAGRAM, MWG3W 200 - 240V, DELTA 50/60Hz

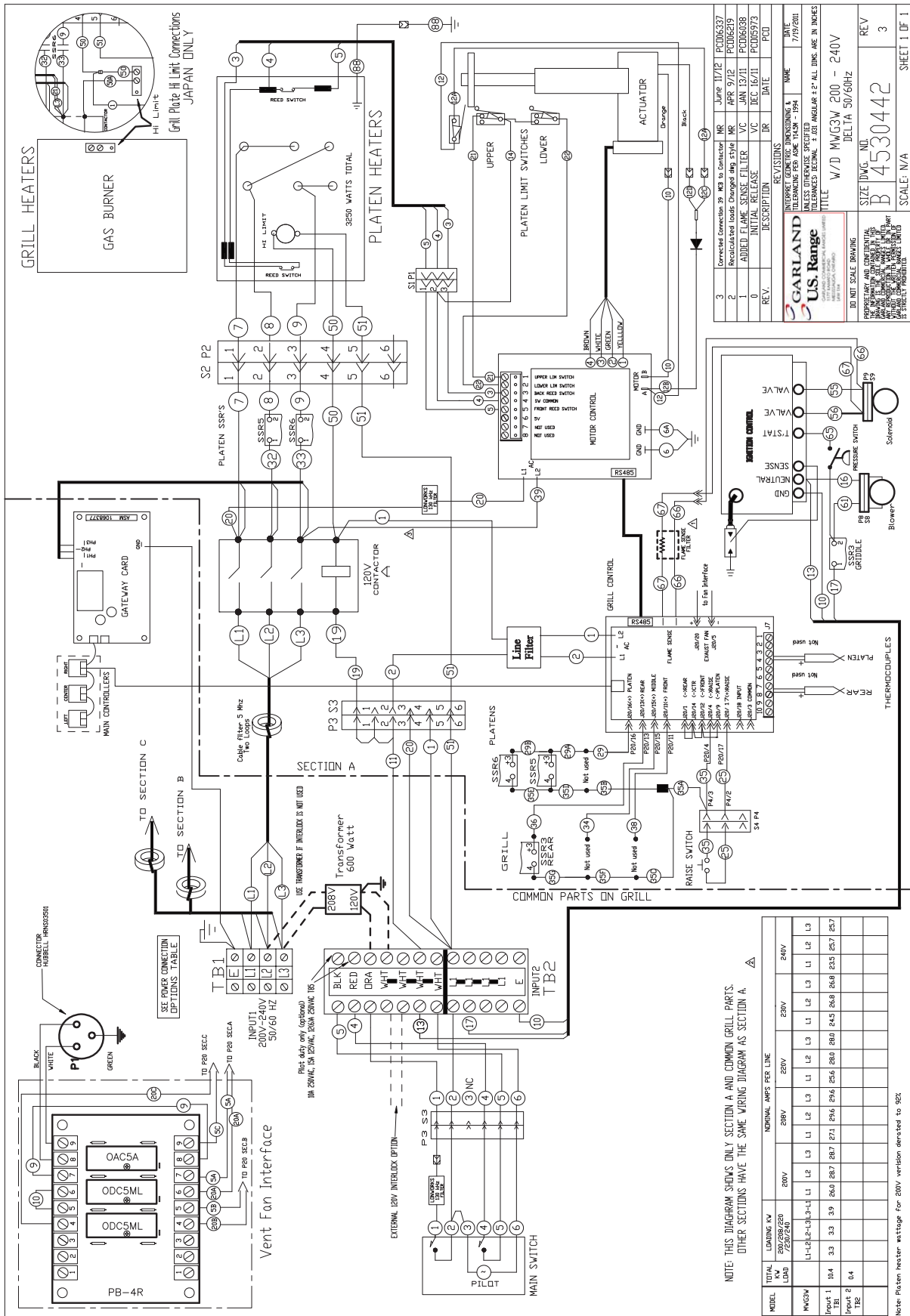

REV.	DESCRIPTION	DATE	BY	CHKD.
3	Connected Connection 29: HES to Connected	7/19/2011	PCU	
2	Specifications Issues Changed and 51/52	7/19/2011	PCU	
1	ADDED INITIAL RELEASE	12/11/2010	PCU	
0	INITIAL RELEASE	12/11/2010	PCU	

**REVISIONS**

INTERPRET GEOMETRIC DIMENSIONING & TOLERANCING PER ASME Y14.5 - 1994	NAME	DATE
UNLESS OTHERWISE SPECIFIED DIMENSIONS ARE IN INCHES		
TITLE	W/D MWG3W 200 - 240V	
SIZE	DELTA 50/60Hz	

REV: 3  
SCALE: N/A  
SHEET 1 OF 1

## **DECLARATION OF CONFORMITY (CE Marked Models)**

**ALL MODELS:**

THE ABOVE PRODUCT SERIES HAS BEEN DESIGNED AND MANUFACTURE IN ACCORDANCE WITH THE FOLLOWING DIRECTIVES AS APPLICABLE AND AMENDED, BASED ON THE LATEST AMENDED HARMONIZED STANDARD

2006/95/EEC	LOW VOLTAGE DIRECTIVE
EN60335-1	SAFETY OF HOUSEHOLD AND SIMILAR ELECTRICAL APPLIANCES

2004/108/EC	ELECTROMAGNETIC COMPATIBILITY DIRECTIVE
IEC/EN 61000-6-1:2007	EMC - IMMUNITY FOR RESIDENTIAL, COMMERCIAL AND LIGHT-INDUSTRIAL ENVIRONMENTS
IEC/EN 61000-6-3:2007	EMC - EMISSION STANDARD FOR RESIDENTIAL, COMMERCIAL AND LIGHT-INDUSTRIAL ENVIRONMENTS

THIS PRODUCT DOES NOT CONTAIN ASBESTOS. THE MATERIALS USED IN THE PRODUCTS NAMED ABOVE ARE SUITABLE FO CONTACT WITH FOOD IN ACCORDANCE WITH FRAMEWORK DIRECTIVE FOR FOOD CONTACT MATERIALS AND ARTICLES (89/109/EEC)

**GAS MODELS:**

THE FOLLOWING REQUIREMENTS AND TEST SPECIFICATIONS ARE CONSIDERED TO E A SUITABLE BASIS FOR DEMONSTRATING COMPLIANCE OF THE ABOVE PRODUCT(S) WITH THE ESSENTIAL REQUIREMENTS OF THE EUROPEAN GAS APPLIANCE DIRECTIVE (90/396/EEC)

EN 203-1:2005 + A1:2008; EN 203-2-9: 205; EN 437:2003 + A1:2009

IN ACCORDANCE WITH ESSENTIAL REQUIREMENT 2.2 IF ANNEX I OF THE EUROPEAN GAS APPLIANCE DIRECTIVE (90/396/EEC), WE GUARANTEE THAT THE MATERIALS USED IN THE ABOVE PRODUCTS ARE APPROPRIATE FOR THEIR INTENDED PURPOSE AND WILL WITHSTAND THE TECHNICAL, CHEMICAL AND THERMAL TO WHICH THEY WILL FORESEE ABLY BE SUBJECTED.

# INDEX

---

---

## A

Accessories Grill 28  
Auto Mode Breakfast 38  
Auto Mode Lunch 38

## B

Beef Integrity 42

## C

Calibration  
Platen  
LEVEL/REED SW mode 58  
Casters Installation 15  
Cleaning 31  
Combustion Level 19  
Content 3, 4  
Control Grill Description 35  
Cooking  
Standby Mode 58  
Cook Time Change 38

## D

Damage Shipping 5  
Declaration of Conformity 124

## E

Error Messaging 36  
Exhaust Hood 18  
Exit Standby Mode 37

## F

Factory Defaults 54  
Factory Default Setting 55  
Form Start Up 19

## I

Installation 14  
Items Included with Grill 14

## L

LEVEL/REED SW mode 58

## M

Magnet Assembly 58  
Maintenance 31  
Manual Mode Breakfast 38  
Manual Mode Lunch 38

## O

Operation Procedures 36

## P

Patty Placement 41  
Photo Accessories 29  
Power Supply Connection 16  
Product Recognition 39  
Programming  
LEVEL/REED SW mode 58  
Programming Menu 44

## R

Release Material Installation 27

## S

Safety 6  
Shutdown Grill 39  
Specification Gas 13  
Specification Mechanical 8, 9  
Splash Shield Installation 26  
Standby mode 58  
Start-Up 14  
System Menu 49  
System Menu Tree 43

## T

Temperature Display 38  
Temperature Probe Calibration 22  
Thermocouple Location 25  
Turn Grill ON 37

## V

Vapor Shield Installation 28

## W

Warranty 5

 **Garland** Installation, Operation & Service Manual



---

3-Platen Gas/Electric Clamshell Grills With Product Recognition

Manufactured Exclusively For McDonald's By  
Garland Commercial Ranges  
<http://www.garland-group.com>

