



Instruction Manual

Corn Treat

Model No. 2174EL, 2174ER
2175EL, 2175ER







GOLD MEDAL[®] PRODUCTS CO.



10700 Medallion Drive, Cincinnati, Ohio 45241-4807 USA







SAFETY PRECAUTIONS

	 DANGER
	<p>Machine must be properly grounded to prevent electrical shock to personnel. Failure to do so could result in serious injury, or death. DO NOT immerse any part of this equipment in water. DO NOT use excessive water when cleaning. Keep cord and plug off the ground and away from moisture. Always unplug the equipment before cleaning or servicing. Make sure all machine switches are in the OFF position before plugging the equipment into the receptacle.</p> <p style="text-align: right; font-size: small;">008_051514</p>

	 DANGER
	<p>Improper installation, adjustment, alteration, service, or maintenance can cause property damage, injury, or death. Any alterations to this equipment will void the warranty and may cause a dangerous condition. NEVER make alterations to this equipment. Read the Installation, Operating, and Maintenance Instructions thoroughly before installing, servicing, or operating this equipment.</p> <p style="text-align: right; font-size: small;">014_051514</p>

	 WARNING
	<p>To avoid burns, DO NOT touch the kettle or any heated surface. DO NOT place or leave objects in contact with heated surfaces.</p> <p style="text-align: right; font-size: small;">013_092414</p>



	 WARNING
	<p>ALWAYS wear safety glasses when servicing this equipment.</p> <p style="text-align: right; font-size: small;">010_010914</p>

	 WARNING
	<p>No user serviceable parts inside. Refer servicing to qualified service personnel.</p> <p style="text-align: right; font-size: small;">011_051514</p>

	 WARNING
	<p>Read and understand operator's manual and all other safety instructions before using this equipment. To order copies of the operator's manual go to gmpopcorn.com or write to Gold Medal Products Co., 10700 Medallion Drive, Cincinnati, OH 45241 USA 1-(800)-543-0862</p> <p style="text-align: right; font-size: small;">022_060215</p>



SAFETY PRECAUTIONS (continued)

	 WARNING
	DO NOT allow direct contact of this equipment by the public when used in food service locations. Only personnel trained and experienced in the equipment operation may operate this equipment. Carefully read all instructions before operation. 012_010914

	 WARNING
	This machine is NOT to be operated by minors. 007_010914

Note: Improvements are always being made to Gold Medal's equipment. This information may not be the latest available for your purposes. It is critical that you call Gold Medal's Technical Service Department at 1-800-543-0862 for any questions about your machine operations, replacement parts, or any service questions. (Gold Medal Products Co. does not assume any liability for injury due to careless handling and/or reckless operation of this equipment.)



INSTALLATION INSTRUCTIONS

Inspection of Shipment

After unpacking, check thoroughly for any damage which may have occurred in transit. Claims should be filed immediately with the transportation company. The warranty does not cover damage that occurs in transit, or damage caused by abuse, or consequential damage due to the operation of this machine, since it is beyond our control (reference warranty in back of manual).

Manual

Read and understand the operator's manual and all other safety instructions before using this equipment. To order copies of the operator's manual go to gmpopcorn.com or write to Gold Medal Products Co., 10700 Medallion Drive, Cincinnati, OH 45241 USA 1-(800)-543-0862.

Model Description

The Mark 5 Corn Treat Unit has a 5 gallon capacity and is available with either right hand or left hand dump capability (see below for unit description). For electrical specifications, refer to the Electrical Requirements section of this manual.

2174EL: 120 Volt Corn Treat Junior, Left Hand Dump

2174ER: 120 Volt Corn Treat Junior, Right Hand Dump

2175EL: 120/208 or 120/240 Volt Mark 5, Left Hand Dump

2175ER: 120/208 or 120/240 Volt Mark 5, Right Hand Dump

Items Included with this Unit

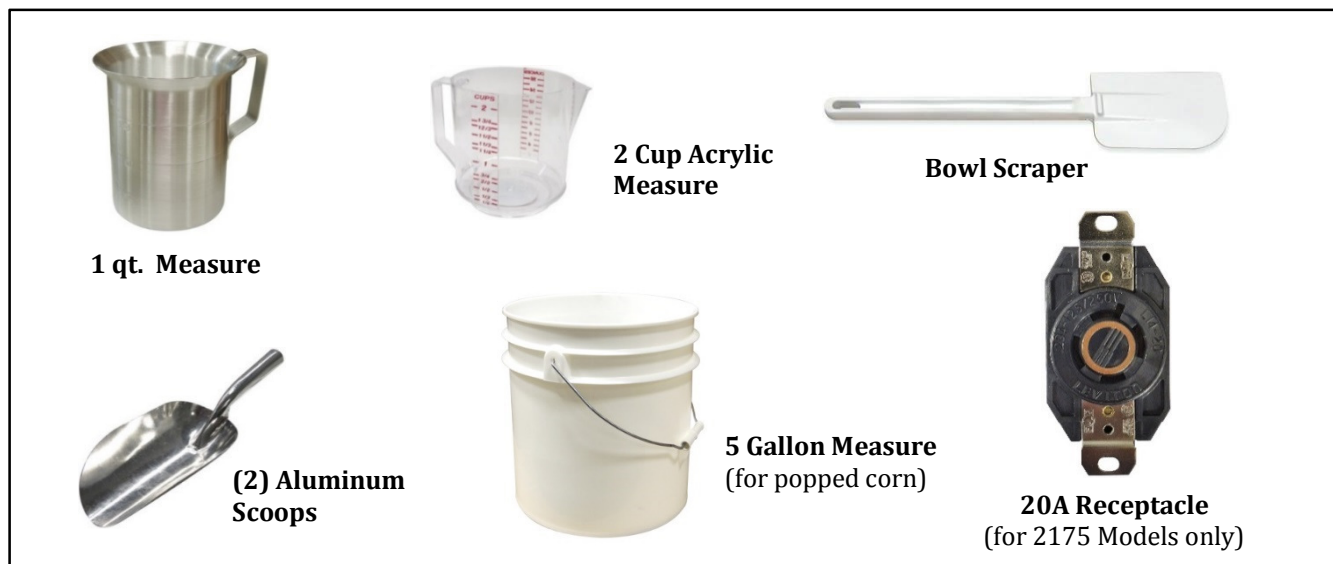



Setup

1. Remove all packaging and tape before starting operation.
2. This unit must be properly fastened to a sturdy counter, see illustration below for counter mounting requirements.

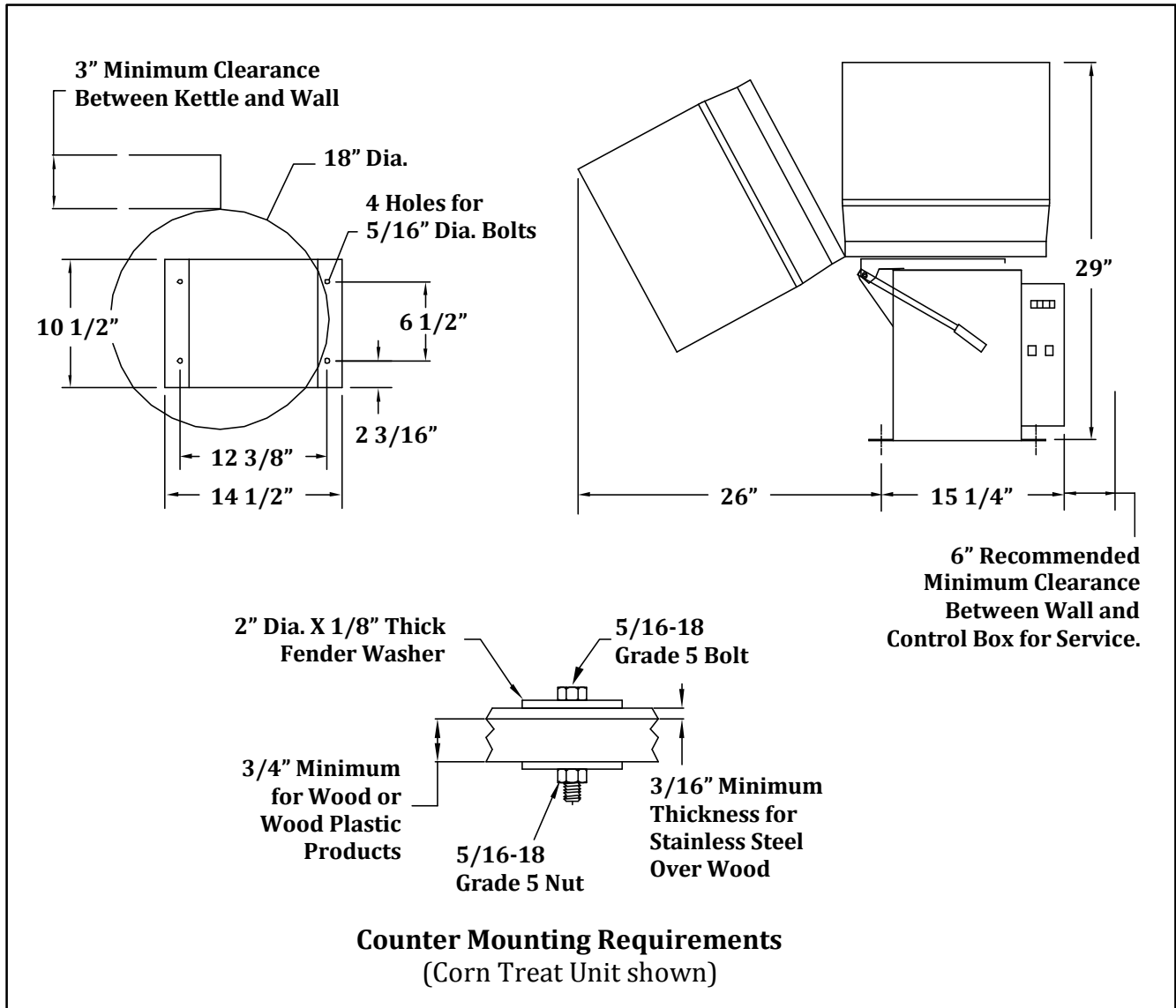



3. Prior to operation, rotate the top paddle from the shipping position into the mixing position and fix into place with the wing bolt provided (see illustration below).
Make sure the wing bolt is securely set into the hole provided in the shaft, then finger tighten to secure paddle in place.
4. After setup, the unit should be cleaned prior to use (see Care and Cleaning section of this manual).

Paddle Assembly

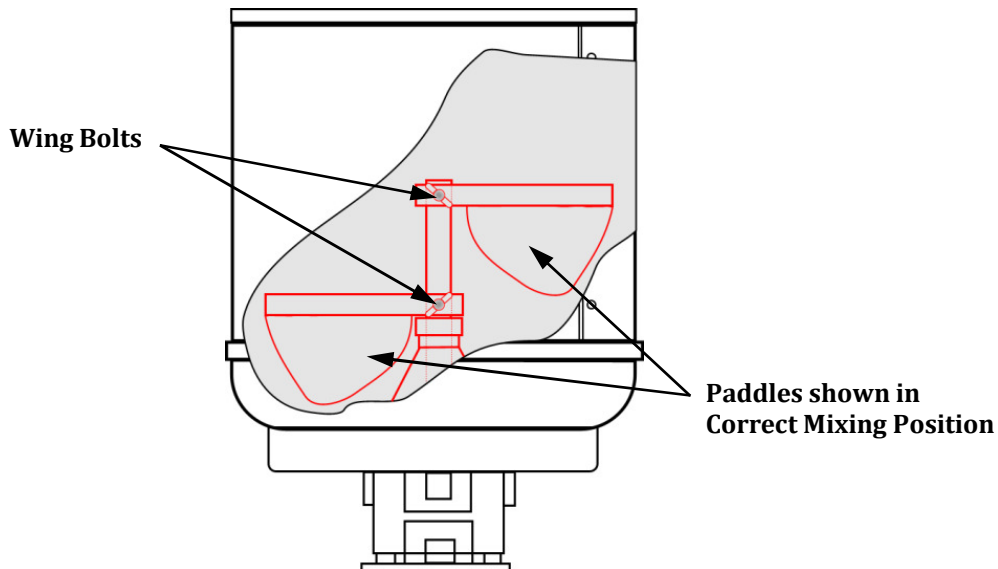



Electrical Requirements



The following power supply must be provided:

2174EL and 2174ER: 120 V~, 3408 W, 60 Hz

This unit requires a NEMA 5-20R receptacle. A certified electrician must supply and install the required wall receptacle.

2175EL and 2175ER: 120/208 or 120/240 V~, 3408 W, 60 Hz

This unit is designed to operate on single phase, 20 AMP, 4 wire supply, 120/208 or 120/240 V~ (2 Hot, 1 Neutral, 1 Ground). All electrical components in this machine are 120 V (motors, heat elements, lights, etc.) and therefore require "Hot to Neutral" connection (**NOT** "Hot to Hot"). A wall receptacle is supplied with the machine. This receptacle will accept the attachment plug on the machine and must be used (reference the Receptacle Installation instructions).

	 DANGER
<p>Machine must be properly grounded to prevent electrical shock to personnel. Failure to do so could result in serious injury, or death. DO NOT immerse any part of this equipment in water. DO NOT use excessive water when cleaning. Keep cord and plug off the ground and away from moisture. Always unplug the equipment before cleaning or servicing. Make sure all machine switches are in the OFF position before plugging the equipment into the receptacle.</p>	
008_051514	

A certified electrician must furnish sufficient power for proper machine operation and install any supplied receptacle. We recommend this equipment be on a dedicated and protected circuit. Failure to wire properly will void the warranty and may result in damage to the machine. It is Gold Medal Products Co.'s recommendation that this machine be plugged directly into a wall outlet. The use of extension cords is not recommended due to safety concerns, and may cause sacrificed and/or reduced performance. Make sure cord is located to prevent a trip hazard or unit upset.



Receptacle Installation for L14-20 (Model 2175 Series ONLY)

A certified electrician must follow the IMPORTANT instructions below for installation of the L14-20 Receptacle (Gold Medal Item No. [41254](#)) provided with Model 2175 Series units.

If the receptacle is wired incorrectly, the heat elements/kettle and other electrical components could be at 208 or 240 V potential instead of the needed 120 V, resulting in excessive temperatures in the heat elements (i.e.: kettle) and possible fire, and/or damage to electrical components.

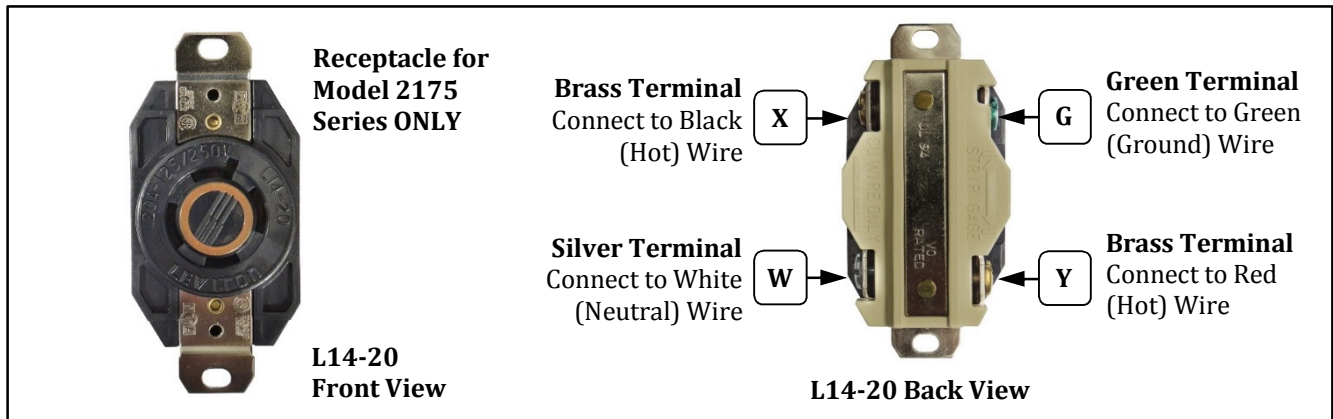

Before You Plug In Machine

1. Make sure all machine switches are in the OFF position before plugging the equipment into the receptacle.
2. Make sure the wall outlet can accept the grounded plugs (where applicable) on the power supply cord.
3. The wall outlet must have the proper polarity. If in doubt, have a competent electrician inspect the outlet and correct if necessary.
4. DO NOT use a grounded to un-grounded receptacle adapter (where applicable).
5. Install the unit in a level position.

	CAUTION
	<p>If the supply cord is damaged, it must be replaced by Gold Medal Products Co., its service agent or similarly qualified persons in order to avoid a hazard.</p> <p style="text-align: right;">039_080614</p>



OPERATING INSTRUCTIONS

Controls and Their Functions

HEAT/MOTOR SWITCH

Two position, ON/OFF lighted rocker switch – provides power to the heating elements in the bottom of the kettle, and powers the agitator motor to turn for 30 seconds of every minute. The green switch light ON indicates there is power to these features.

Note: It is normal for the motor to stop for 30 seconds of every minute (when the Motor Only Switch is OFF).

MOTOR ONLY SWITCH

Two position, ON/OFF lighted rocker switch – provides power to the agitator motor to run continuously.

Note: The main function of this switch is for mixing the product/popcorn at the end of the cooking cycle with the kettle in the tilt position, and it is used for “cleaning mode”.

HEAT CONTROL

The Heat Control adjusts the Product Cook Temperature of the unit (potentiometer is located behind the silver hole plug). The machine is factory preset for a Product Cook Temperature of 280°F. See Heat Control Adjustment / Calibration section for adjusting the product cook temperature.

CIRCUIT BREAKER

The Circuit Breaker protects the Motor and Heat Control from an overload condition.

KETTLE DUMP HANDLE

The Kettle Dump Handle tilts the kettle from the upright, cook position, to the mix position or the dump position.

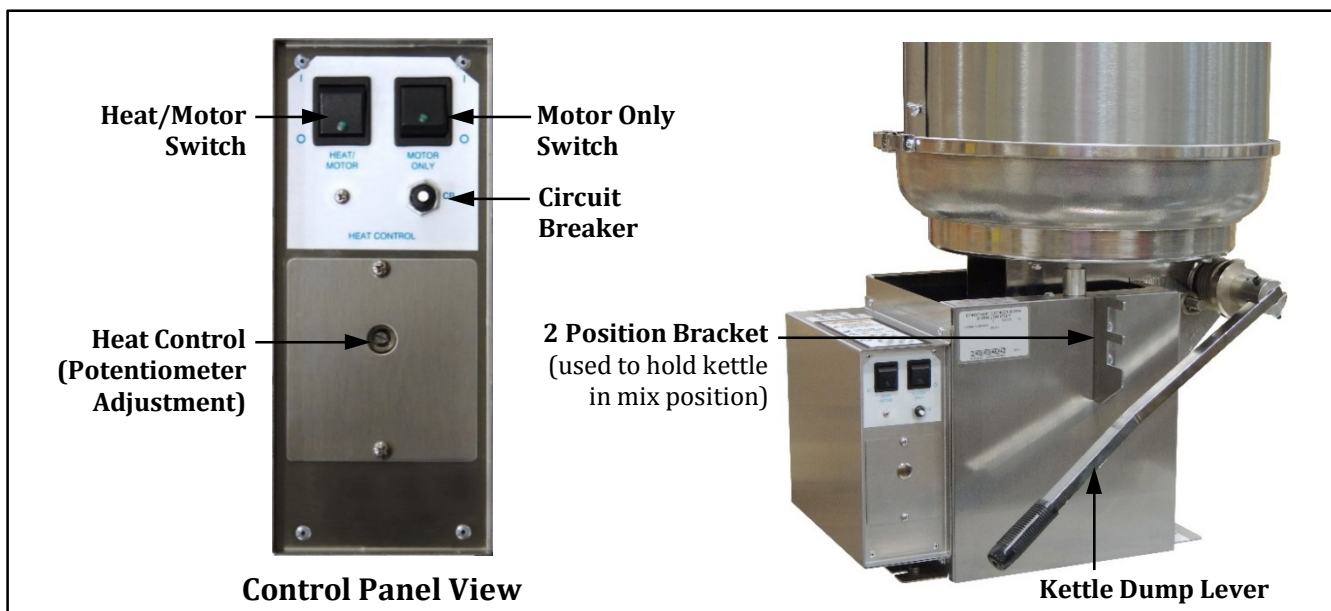



Heat Control Adjustment/Calibration

Product Cook Temperature is the actual temperature of the PRODUCT (Caramel Corn Mix); this is measured with an accurate candy thermometer. Infrared temperature readers are NOT recommended.

Standard Heat Control Adjustment

The machine comes from the factory preset to achieve a finished **Product Cook Temperature** of 280°F. Small adjustments may need to be made for mix used or cooking conditions. If the mix is ready, either before or after the buzzer sounds, then follow the steps listed to adjust the cook temperature of the unit:

Note: The sound of the buzzer signals kettle heat shut-off.

1. Remove the silver hole plug located on the front panel of the control box. This will allow you to access the heat control's potentiometer adjustment.
2. Turn the potentiometer slightly clockwise to increase the temperature, or counterclockwise to decrease the temperature.

Standard Heat Control Calibration (Performed at the Factory)

This unit has been calibrated at the factory. Other than small adjustments made for mix used or cooking conditions (see above Standard Heat Control Adjustments), the unit is ready for use and should not need calibration.

To reset the Standard Heat Control back to factory settings follow the procedure shown below.

Note: For calibration purposes only, corn oil is used to determine the Standard Heat Control temperature setting which will produce an accurate finished product temperature of 280°F.

1. Start with a clean unit, which is cool before attempting to calibrate.
2. Fill the mixing bowl with a one inch depth of corn oil.
3. Turn the Heat/Motor Switch ON.
4. Use an accurate candy thermometer to measure the temperature of the oil in the mixing bowl. (Infrared temperature readers are NOT recommended.)
5. Turn the Motor Only Switch ON to stir the oil while it heats.
6. When the oil reaches 325°, slowly turn the potentiometer counterclockwise until the buzzer sounds. If buzzer sounds before the temperature reaches 325°F, turn the potentiometer clockwise until the buzzer stops and continue to turn an additional 1/8 turn.

Note: The sound of the buzzer signals kettle heat shut-off.

7. Allow oil to cool below 300°F, then repeat Step 4 to check the buzzer sounds at 325°F.
8. The unit is now calibrated for the heat control buzzer to sound at a finished product temperature of 280°F.

Caution: Allow hot oil to cool below 140°F before attempting to drain.



Making Carmel Corn

Instructions for Making Carmel Corn

Always remember, leave the lid on the kettle during the first part of the batch. Once steam starts to “roll-up” from underneath the lid, then carefully remove lid for remainder of the cooking cycle.

CAUTION: Beware of rising steam; keep face and hands clear of rising steam.

1. Turn Heat/Motor Switch ON (DO NOT turn on the Motor Only Switch).
2. Add (1) 22 ounce package of Gold Medal Caramel Corn Mix (Item No. 2094), 4 cups of granulated sugar (brown or white), and 8-12 ounces of water (add water last).
Note: When using Gold Medal “One Step” Caramel Corn Mix, **DO NOT** add granulated sugar.
3. Turn Motor Only Switch ON and mix for approximately one minute, then turn Motor Only Switch OFF. (With the Heat/Motor Switch ON, the motor will run for 30 seconds of every minute.)
4. Add 1 stick (4 ounces) of coconut oil or vegetable oil. Put on the lid.
Note: Once steam starts to “roll-up” from underneath the lid, then carefully remove lid for remainder of the cooking cycle.
5. Allow mix to cook until the buzzer sounds at 280°F product temperature.
Note: Product temperature is measured with an accurate candy thermometer. (Reference the Heat Control Adjustment section.)
6. Turn Heat/Motor Switch OFF.
7. Turn Motor Only Switch ON.
8. Add 5 gallons of pre-popped corn.
9. Allow corn to mix for approximately 10 seconds with the kettle in the upright position.
10. Move kettle to the mix position and spray 10-12 “squirts” of GOLD Medal Free-N-Easy (Item No. 2250) for proper corn separation; mix popcorn until thoroughly coated.
11. Dump the caramel corn into the cooling pan, and mix/separate the caramel corn using two popcorn scoops.
12. After dumping caramel corn, turn Motor Only Switch OFF.
13. Allow the finished product to cool before packaging.

During normal operation, sugar build-up will occur in the kettle. The build-up must be removed by steaming out the kettle every 3-4 batches, and especially before the machine is turned off for the day. If making single batches, with the unit turned off between batches, the kettle must be steamed out after each batch has been completed. Follow the Proper Kettle Cleaning Procedure in the Care and Cleaning section of this manual.



Care and Cleaning

	⚠ DANGER
	<p>Machine must be properly grounded to prevent electrical shock to personnel. DO NOT immerse in water. Always unplug the equipment before cleaning or servicing.</p> <p style="text-align: right;">025_020314</p>

	⚠ WARNING
	<p>To avoid serious burns, DO NOT touch the kettle while it is hot!</p> <p style="text-align: right;">028_082715</p>

Good sanitation practice demands that all food preparation equipment be cleaned regularly (only use non-toxic, food grade cleaners). A clean looking, well-kept machine is one of the best ways of advertising your product.

Corn Treat Cleaning Instructions

Note: It is extremely important to follow all of the cleaning procedures, otherwise parts damage and equipment failure will result. The warranty does not cover parts that are damaged due to improper cleaning.

Proper Kettle Cleaning Procedure

Follow the procedure below to steam the sugar build-up out of the kettle every 3-4 batches during regular operation and before the machine is turned off for the day. The kettle must also be steamed out after making single batches, if the machine is turned off between batches.

1. After all product has been removed, and the kettle has cooled for 15-20 minutes, carefully pour 24 oz. of water into the kettle.

CAUTION: Beware of rising steam; keep face and hands clear of rising steam.

2. Place the lid on the kettle, and turn the Heat/Motor Switch ON.
3. When water starts to boil, turn Heat/Motor Switch OFF.
4. Turn the Motor Only Switch ON; allow the machine to cool, then remove the lid and carefully pour the contents of the kettle into a pan or bucket. Steam the kettle twice to remove all traces of product.
5. Turn the Motor Only Switch OFF.
6. With all switches OFF, wipe out any excess sugar build-up from the kettle using a damp rag, then the kettle is ready to begin another batch.
7. Do not leave water in the pans overnight.



Daily Unit Cleaning Procedure

Follow the directions below to clean and sanitize the unit each day after use.

1. With the machine OFF, unplug the unit and allow it to cool before attempting to clean.
2. Make sure to clean all pans/accessories in order to sanitize them before each use.
3. Release the draw latch to easily remove the mixing drum, then remove paddles. The mixing drum and paddles can be taken to the sink to clean.
4. Wipe the kettle lead cord with a clean **SLIGHTLY** damp cloth. **DO NOT get moisture into the kettle lead-in cord, severe damage will result.**
5. The cabinet of your machine should be wiped clean daily (or more, depending on usage) with a clean soft cloth, SLIGHTLY dampened with soap and hot water.
6. Wipe the stainless steel parts with a clean cloth and cleaner designed for stainless steel, such as Gold Medal Watchdog Stainless Cleaner (Item No. 2088).
DO NOT use oven cleaners or abrasive materials as they will damage parts of the machine.

Proper Hub Seal Assembly Cleaning Procedure

Follow the steps below weekly to ensure proper machine performance:

Important: For proper machine performance, keep the hub seal and o-rings clean.

1. With the machine OFF, unplug the unit from the power source and allow it to cool before attempting to clean the Hub Seal Assembly.
2. Loosen the wing bolt(s) (Mixing Paddle Lock Studs) and remove the mix paddles.
3. Remove any burrs on the shaft using a fine grit emery paper to lightly sand the surface. If the burrs are not removed, damage may occur to the o-ring/oil seal during removal/installation.
4. Remove the hub seal assembly and soak it in hot water to clean.
5. Clean the area around the center hub. Remove any product residue. (See Kettle Shaft Maintenance for note on lubricating the kettle bushings.)
6. Lightly lubricate the center hub of the kettle with a small amount of vegetable oil to allow for easy re-installation of the hub seal assembly.
7. Slide the clean hub seal assembly down the agitator shaft. Apply pressure to ease the assembly over the center hub of the kettle until it seats properly (reference image shown.)
8. After the hub seal assembly has been properly installed, re-install the mix paddles onto the agitator shaft.
9. Finger tighten the wing bolt(s) to secure mixing paddles in place.



Hub Seal and Paddle Assembly

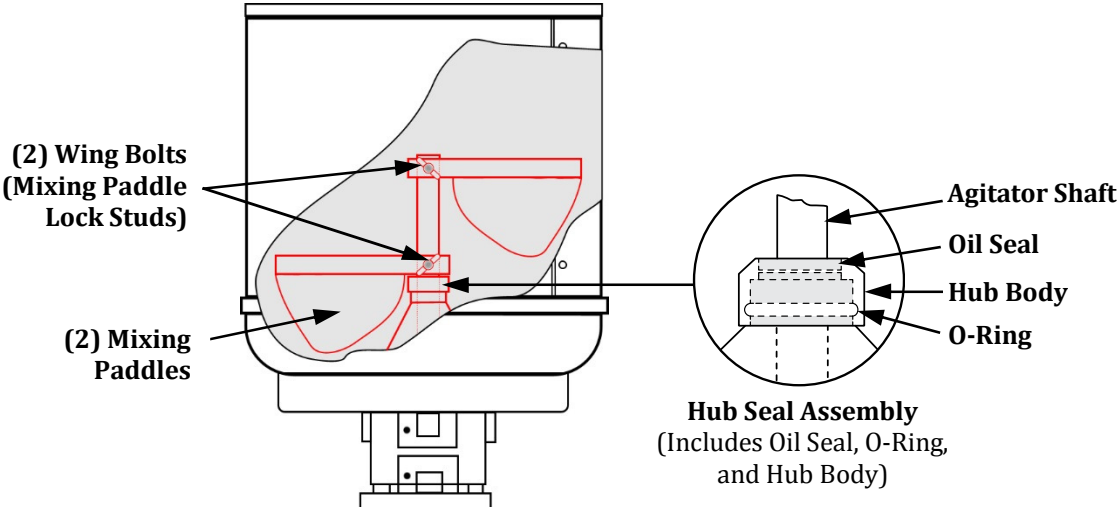





Troubleshooting

Issue	Possible Cause	Solution
Kettle Does Not Heat	A. Power to Unit B. Circuit Breaker C. Kettle Heat/Motor Switch D. Control	A. Make sure the unit lead-in cord is plugged in. B. Check the condition of the circuit breaker. The breaker may trip during transit, if reset and trips again, contact qualified service personnel for inspection/repair before going any further. C. Have qualified service personnel check the voltage to and from the Heat/Motor Switch; if switch is defective, replace it. D. A defective RTD lead will cause the kettle not to heat. Have qualified service personnel check for good connections from the kettle to the control.
Kettle Agitator Does Not Turn	A. Kettle Agitator Shaft/Motor Shaft	A. If the kettle agitator shaft is not rotating, DO NOT use. Have qualified service personnel inspect/repair as needed.
Long Cooking Cycles	A. Heating Element B. Low Voltage C. Inadequate Supply Lines	A. One of the heating elements in the kettle may be burned out. This would result in the kettle never reaching the proper operating temperature. Contact qualified service personnel for inspection/repair. B. Unit is designed to make approximately 3 batches per hour when operated at full voltage (approx. 2 batches per hour for Model Series 2174). To get the unit warmed up, the first batch usually takes about 5 minutes longer. If the machine is operated on low voltage, this could cause the kettle not to reach the proper operating temperature. 120 V units need a 105 V minimum. C. Inadequately sized electrical supply lines, in addition to being a fire hazard, would also prevent the kettle from reaching the proper operating temperature. Check with a qualified electrician.



MAINTENANCE INSTRUCTIONS

	⚠ DANGER
	<p>Machine must be properly grounded to prevent electrical shock to personnel. Failure to do so could result in serious injury, or death. DO NOT immerse any part of this equipment in water. DO NOT use excessive water when cleaning. Keep cord and plug off the ground and away from moisture. Always unplug the equipment before cleaning or servicing. Make sure all machine switches are in the OFF position before plugging the equipment into the receptacle.</p> <p>008_051514</p>

	⚠ DANGER
	<p>Improper installation, adjustment, alteration, service, or maintenance can cause property damage, injury, or death. Any alterations to this equipment will void the warranty and may cause a dangerous condition. NEVER make alterations to this equipment. Read the Installation, Operating, and Maintenance Instructions thoroughly before installing, servicing, or operating this equipment.</p> <p>014_051514</p>

	⚠ WARNING
	<p>No user serviceable parts inside. Refer servicing to qualified service personnel.</p> <p>011_051514</p>

	⚠ CAUTION
	<p>THE FOLLOWING SECTIONS OF THIS MANUAL ARE INTENDED ONLY FOR QUALIFIED SERVICE PERSONNEL WHO ARE FAMILIAR WITH ELECTRICAL EQUIPMENT. THESE ARE NOT INTENDED FOR THE OPERATOR.</p> <p>027_010914</p>



New Paddle/Hub Seal Kit Installation Kettle Shaft Maintenance

1. With the machine OFF, unplug unit from the power source and allow it to cool.
2. Loosen the wing bolts (Mixing Paddle Lock Studs) and remove the mix paddles.
3. Remove any burrs on the shaft using a fine grit emery paper to lightly sand the surface. If the burrs are not removed, damage may occur to the new o-ring/oil seal during installation.
4. Remove the old hub seal assembly.
5. Clean the area around the center hub. Remove any product residue.

Note: The kettle shaft should be removed monthly and the bushings lubricated with Never Seez® (use White Food Grade **ONLY**). To do this, loosen the (2) set screws in the jaw coupling and remove the shaft. **DO NOT lose the shaft key; this must be reset into place when reassembling.**

6. Lightly lubricate the center hub of the kettle with a small amount of vegetable oil to allow for easy installation of the hub seal assembly.
7. Slide the new hub seal assembly down the agitator shaft. Apply pressure to ease the assembly over the center hub of the kettle until it seats properly (see image below.)
8. After the hub seal assembly has been properly installed, re-install the mix paddles onto the agitator shaft.
9. Finger tighten the wing bolts to secure mixing paddles in place.
10. Rotate shaft by hand to ensure paddle does not touch the kettle bottom; re-adjust shaft as needed.

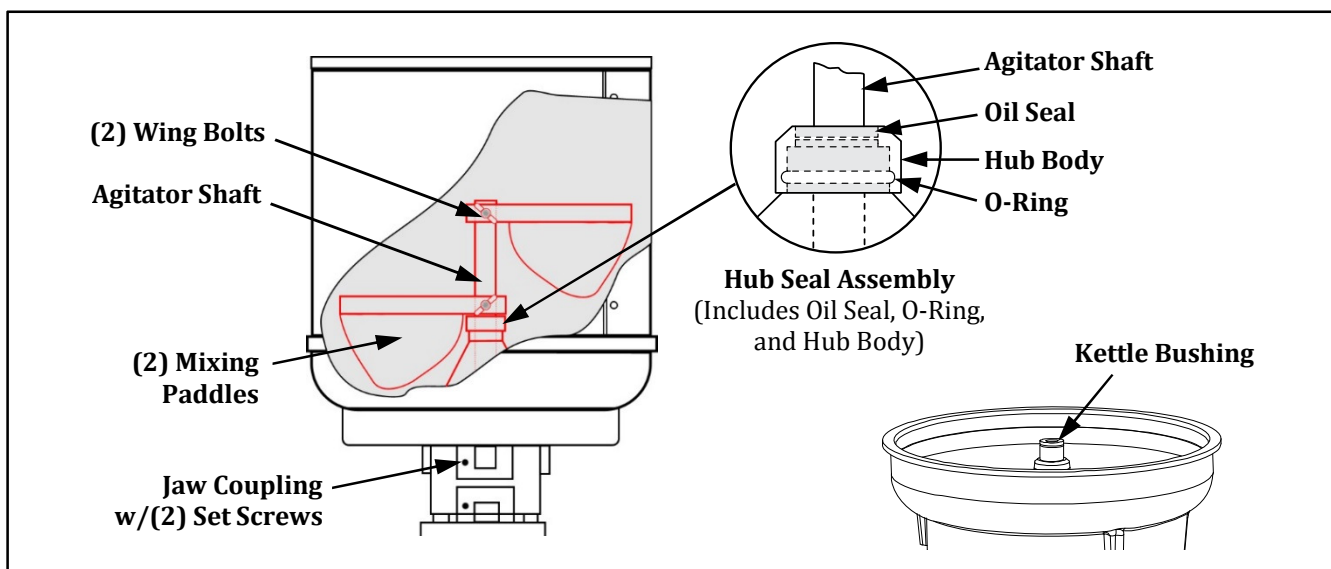



ORDERING SPARE PARTS

1. Identify the needed part by checking it against the photos, illustrations, and/or parts list.
2. Use only approved replacement parts when servicing this unit.
3. When ordering, please include part number, part name, and quantity needed.
4. Please include your model number, serial number, and date of manufacture (located on the machine nameplate/data plate) with your order.
5. Address all parts orders to:

Parts Department
Gold Medal Products Co.
10700 Medallion Drive
Cincinnati, Ohio 45241-4807

Or, place orders by phone or online:

Phone: (800) 543-0862
(513) 769-7676
Fax: (800) 542-1496
(513) 769-8500
E-mail: info@gmpopcorn.com
Web Page: gmpopcorn.com



Cabinet Exterior – Parts Breakdown

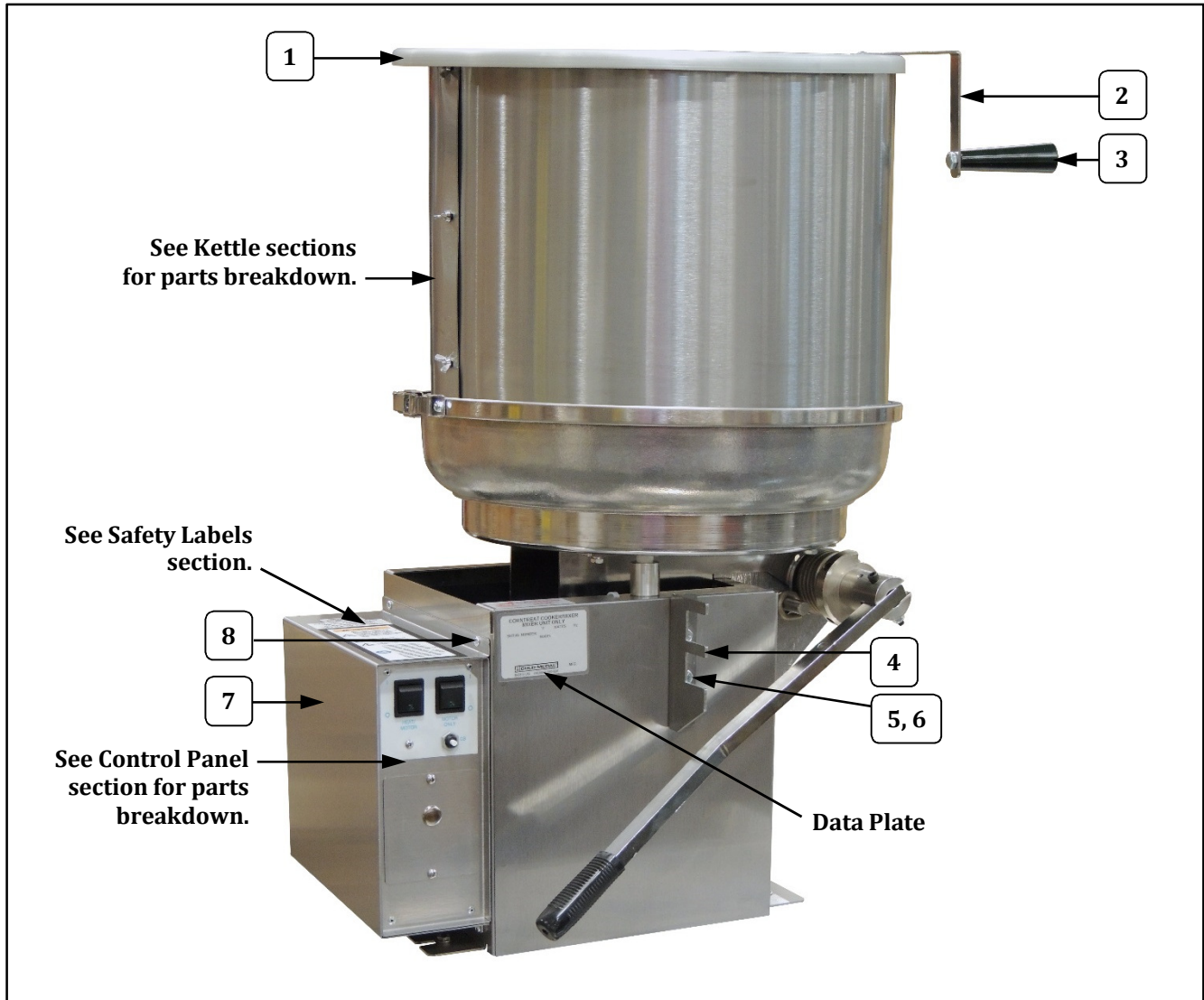

Item	Part Description	Part No.
		All Models
1	LID ASSEMBLY (includes handle)	67216
2	HANDLE BRACKET	67182
3	PLASTIC HANDLE	76075
4	2 POSITION BRACKET	46153
5	1/4-20 X 3/4 GRADE 5 BOLT	74520
6	1/4-20 SERRATED LOCK NUT	46311
7	CONTROL BOX COVER	55453
8	8-32 X 1/4 PHIL PAN M/S	87314

Cabinet Exterior/Spring Assembly – Parts Breakdown

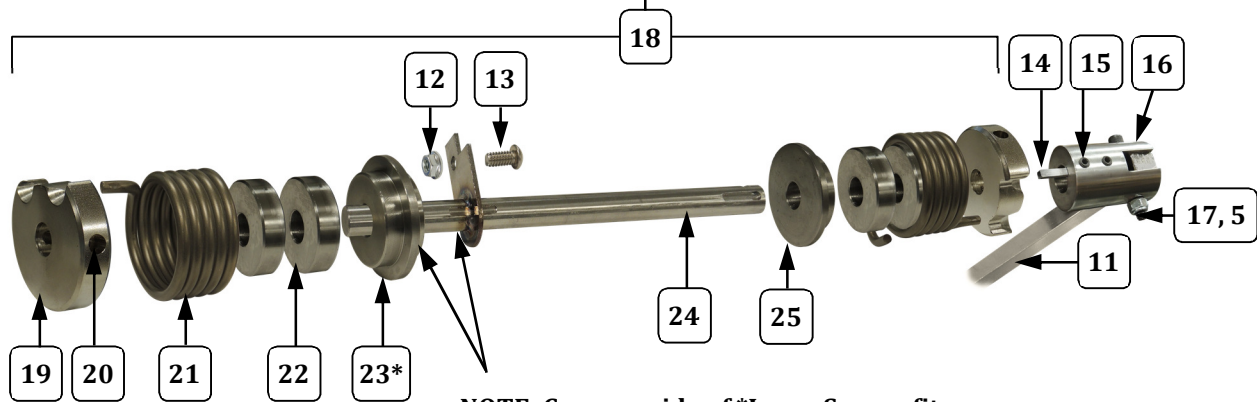
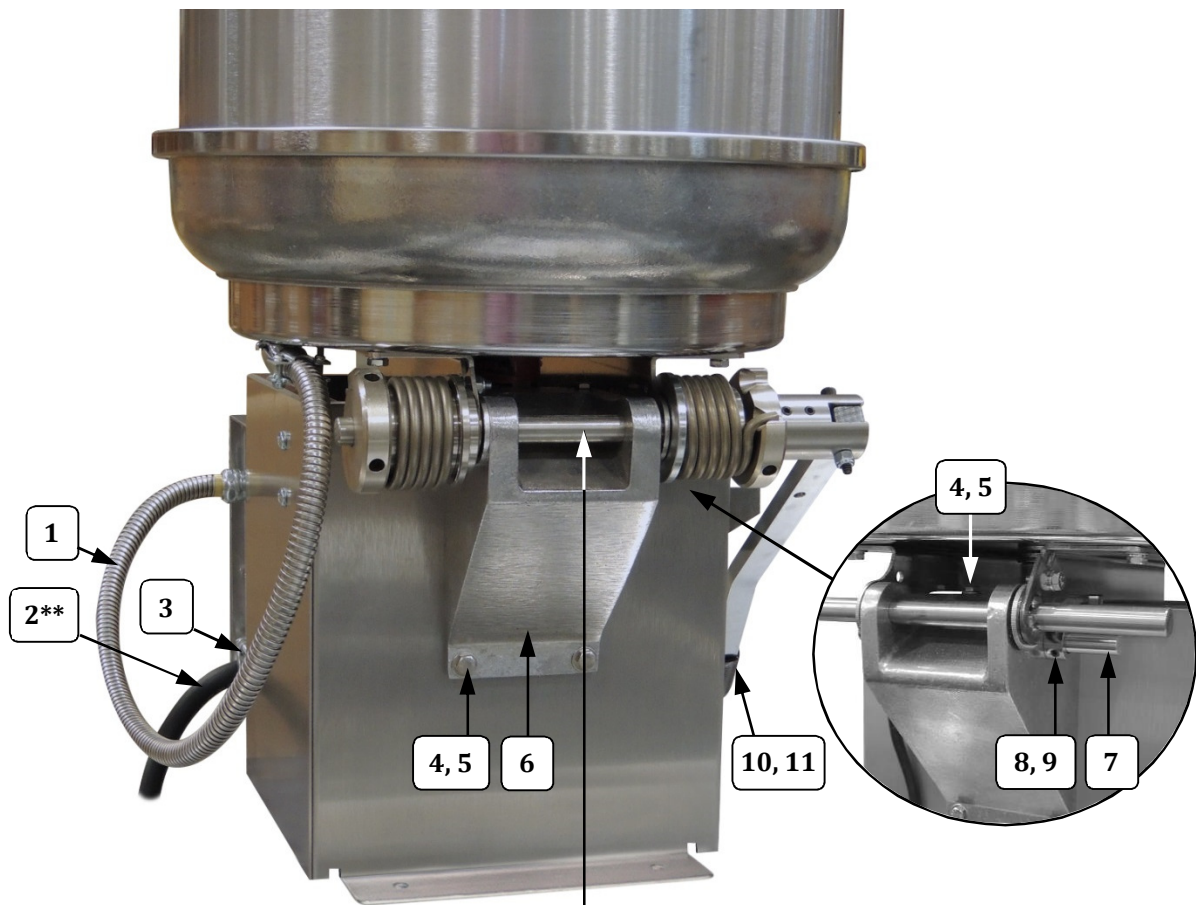

NOTE: Concave side of *Large Spacer fits up against bracket weld on Dump Bar Shaft.

**** CAUTION:** If supply cord is damaged, it must be replaced by Gold Medal Products Co., its service agent, or similarly qualified persons in order to avoid a hazard.



Cabinet Exterior/Spring Assembly – Parts List

Item	Part Description	Part No.			
		2174EL	2174ER	2175EL	2175ER
1	KETTLE LEAD IN ASSY (includes connectors)	48769	48769	48769	48769
2**	LEAD-IN CORD ASSY.	47580	47580	41034	41034
3	STRAIN RELIEF T&B 3304	82227	82227	82227	82227
4	1/4-20x3/4 BUTTON HD SC	67927	67927	67927	67927
5	HEX NUT 1/4-20 ESLOK	42361	42361	42361	42361
6	KETTLE MTNG BRKT MACHINED	106060	106060	106060	106060
7	SPRING RETAINER ROD	82551	82551	82551	82551
8	SET COLLAR 1/2ID X 7/8OD	47326	47326	47326	47326
9	SET SCREW 1/4-20 X 3/16 (1 req'd. per collar)	47751	47751	47751	47751
10	GRIP, HANDLE BAR	46028	46028	46028	46028
11	TILT LEVER 1/2X3/4 CD BAR	46006	46006	46006	46006
12	1/4-20 SERRATED LOCK NUT (top side of bracket use a 1/4-20 ESLOK Hex Nut)	46311	46311	46311	46311
13	1/4-20X1/2 BUTN HD SCREW	79242	79242	79242	79242
14	KEY (.187 X .187 X 3/4)	12509	12509	12509	12509
15	SET SCREW 1/4-20 X 3/8	74125	74125	74125	74125
16	HUB	16707	16707	16707	16707
17	SOCKET HEAD 1/4-20 SCREW	77893	77893	77893	77893
18	LEFT SPRING & DUMP BAR ASSEMBLY (assembly includes items listed below)	16710		16710	
	RIGHT SPRING & DUMP BAR ASSEMBLY (assembly includes items listed below)		16709		16709
19	COLLAR	74661	74661	74661	74661
20	SET SCREW, 5/16-18 X 5/8 (3 req'd. per collar)	74662	74662	74662	74662
21	TORSION SPRING	74660	74660	74660	74660
22	SPACER	74658	74658	74658	74658
23*	SPACER,LARGE (DUMP SIDE) - Concave side fits up against bracket weld on Dump Bar Shaft	74659	74659	74659	74659
24	RIGHT DUMP BAR WELDMENT		16705		16705
	LEFT DUMP SHAFT WELDMENT	16706		16706	
25	SPACER,LARGE (CUSTOMER SIDE)	74690	74690	74690	74690



Kettle and Drum – Parts Breakdown

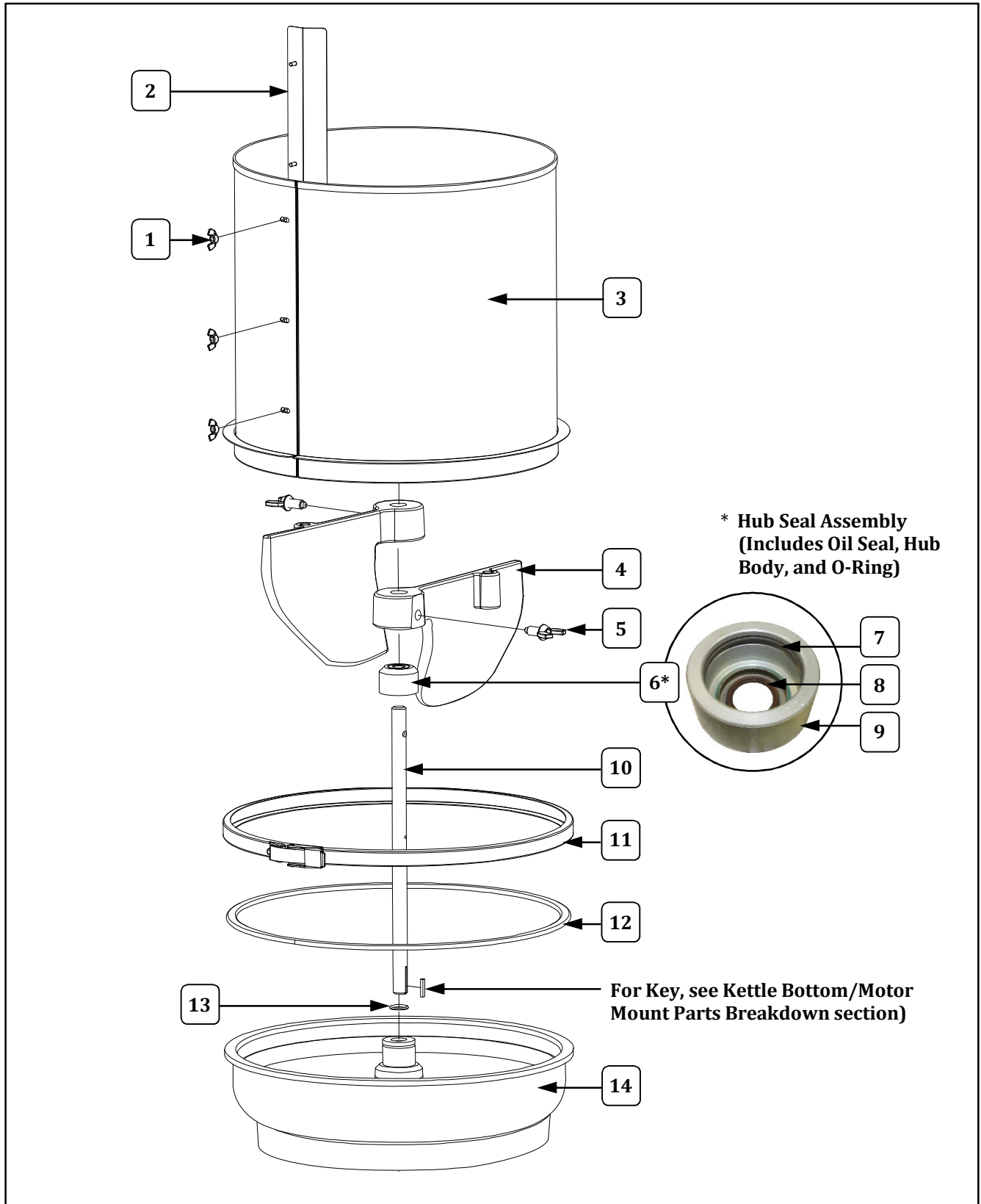



Kettle and Drum – Parts List

Item	Part Description	Part No.	
		2174EL 2174ER	2175EL 2175ER
1	WING NUT, #8-32	89126	89126
2	BLENDING STRIP	46532	46532
3	MIXING DRUM	46288	46288
4	MIXER PADDLE	46286	46286
5	MIX PADDLE LOCK STUD ASSY	46203	46203
6	HUB SEAL ASSY (includes Oil Seal, Hub Body, and O-Ring)	46632	46632
7	O-RING 1 3/4ID X 2OD	46631	46631
8	HUB SEAL	46630	46630
9	HUB SEAL BODY	46629	46629
10	AGITATOR SHAFT	46143	46143
11	RETAIN RING ASSY	46651	46651
12	DRUM SEAL	46701	46701
13	O-RING BUSHING SEAL	46119	46119
14	KETTLE ASSY (includes Shaft, Hub Seal Assy, Retaining Ring and Drum Seal; also see Kettle Bottom and Kettle Element View sections for itemized parts breakdown).	68007F	68015F



Kettle Bottom Plate/Motor Mount – Parts Breakdown

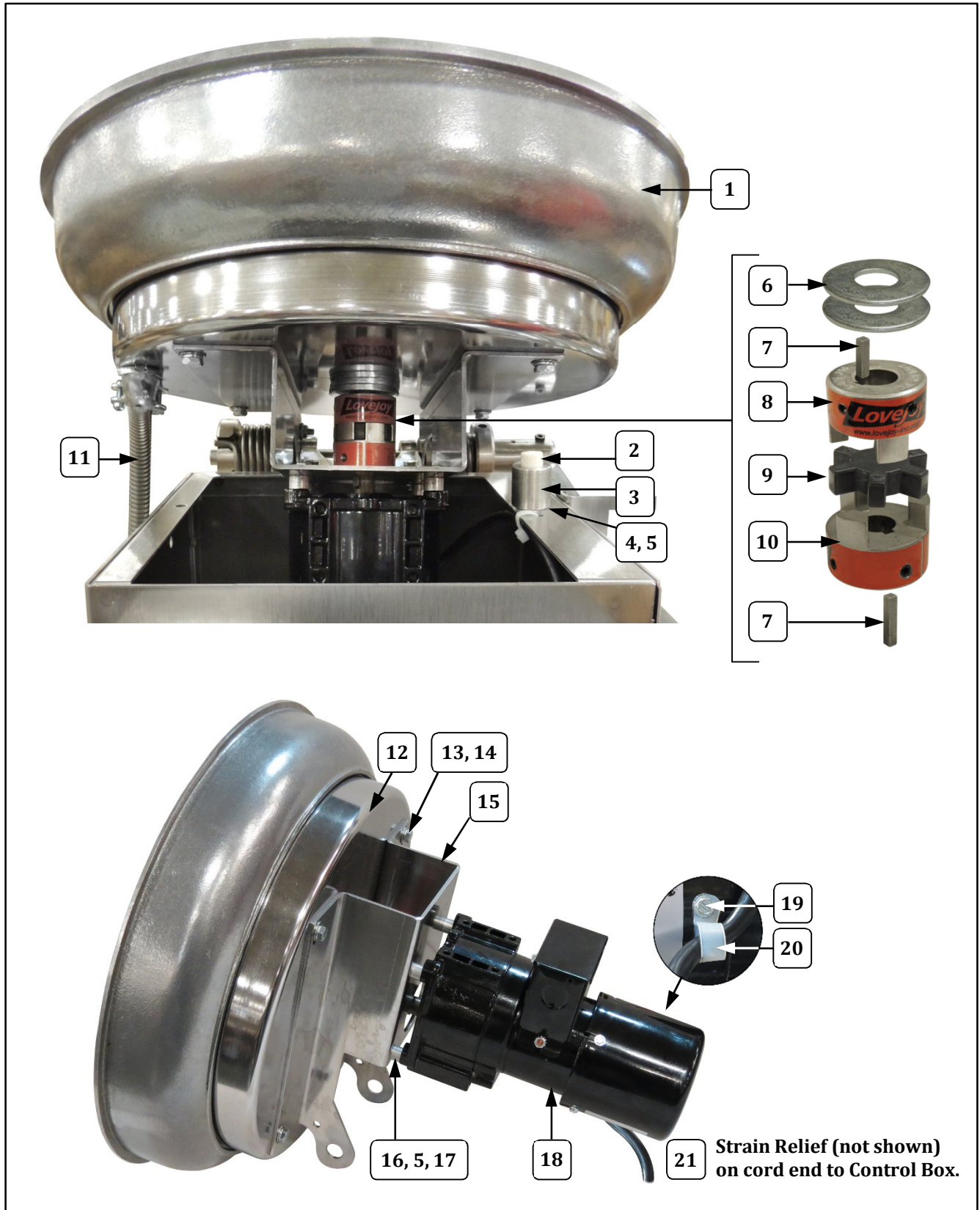



Kettle Bottom Plate/Motor Mount – Parts Breakdown

Item	Part Description	Part No.	
		2174EL 2174ER	2175EL 2175ER
1	KETTLE ASSY (includes Shaft, Hub Seal Assy, Retaining Ring and Drum Seal; also see Kettle Bottom and Kettle Element View sections for itemized parts breakdown).	68007F	68015F
2	KETTLE REST BUMPER	83111	83111
3	KETTLE REST (metal rest/holds bumper)	83113	83113
4	1/4-20 X 1/2 P/H PHIL (fastens Kettle Rest)	12471	12471
5	WASHER 1/4 INTERNAL TOOTH	12383	12383
6	13/16"ID 2"OD FLAT WASHER	77892	77892
7	KEY (.187 X .187 X 3/4) (one used for agitator shaft, one used for motor shaft)	12509	12509
8	3/4 BORE COUPLING BODY (includes set screws)	46145	46145
9	FLEXIBLE SPIDER	12141	12141
10	5/8 BORE COUPLING BODY(includes set screws)	46144	46144
11	KETTLE LEAD IN ASSY	48769	48769
12	BOTTOM COVER	67995	67995
13	1/4-20 X 3/4 GRADE 5 BOLT	74520	74520
14	1/4 FLAT WASHER STAINLESS	87261	87261
15	MOTOR MOUNT (bracket)	16708	16708
16	1/4-20 x 1 1/4 HEX CAP (fastens motor)	48571	48571
17	MOTOR SPACER	67207	67207
18	DRIVE MOTOR	82085B	82085B
19	8-32 X 3/8 SLT. HWH M/S	42044	42044
20	CABLE CLAMP	87219	87219
21	STRAIN RELIEF (Plastic Strain Relief on cord end to Control Box)	76026	76026



Kettle Element View – 2174 Series

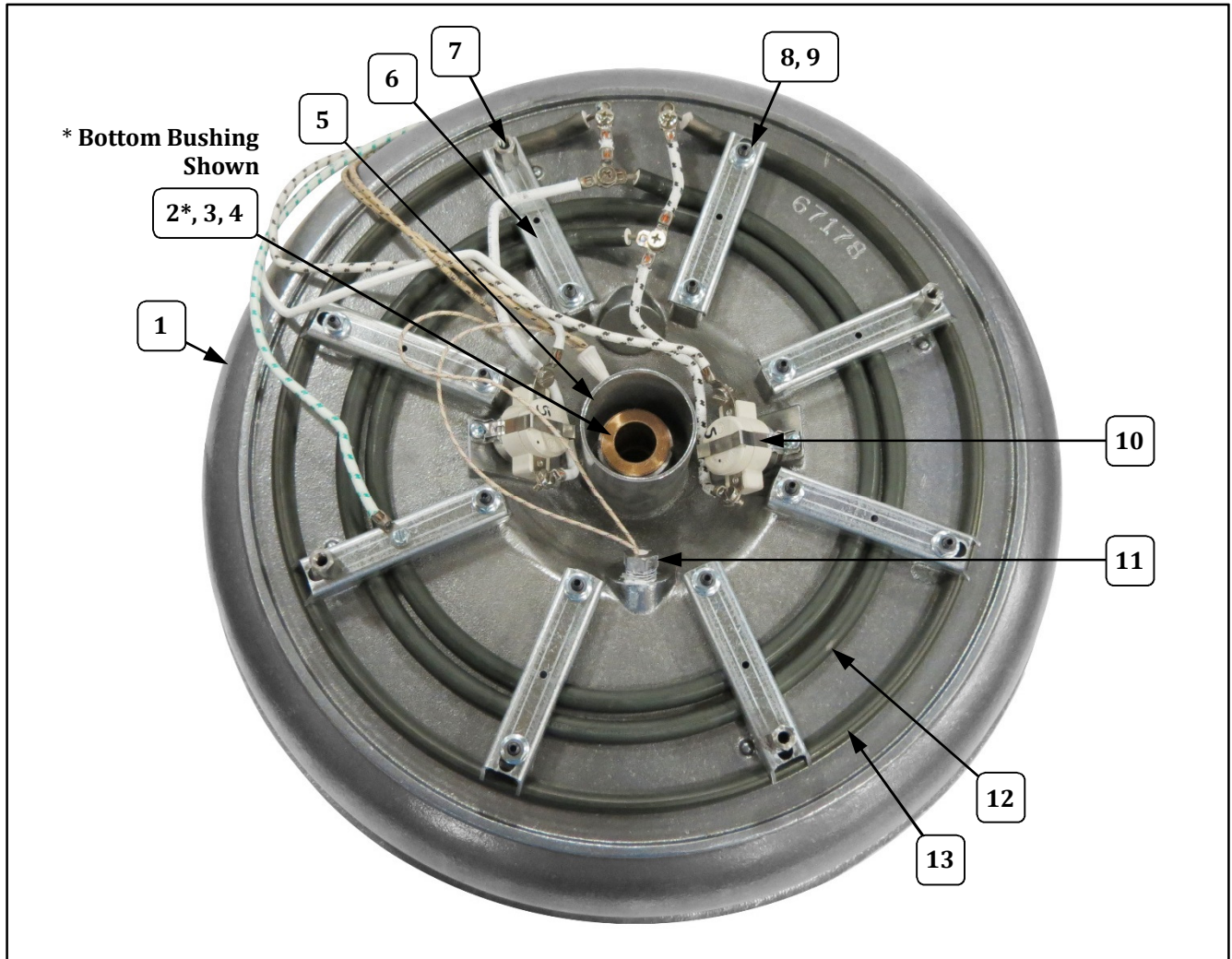

Item	Part Description	Part No.
		2174EL 2174ER
1	KETTLE, CORN TREAT CENTER (includes bushings shown below)	46280
2	BUSHING, MIX BOWL (bottom bushing shown)	46065PMO
3	BUSHING, MIX BOWL (top bushing not shown; bushing is machined to fit o-ring listed below)	46065
4	O-RING BUSHING SEAL	46119
5	SHAFT COVER	12581
6	ELEMENT RETAINER BRKT	67174
7	STANDOFF 11/16 IN	12889
8	SET SCREW 10-24 X 1	46627
9	10-24 SERRATED LOCK NUT	49363
10	L-510 THERMOSTAT KETTLE (2 required)	82219
11	RTD HEAT SENSOR	46299
12	TUBULAR ELEMENT, 1500W	48800
13	TUBULAR ELEMENT, 275W	46439



Kettle Element View – 2175 Series

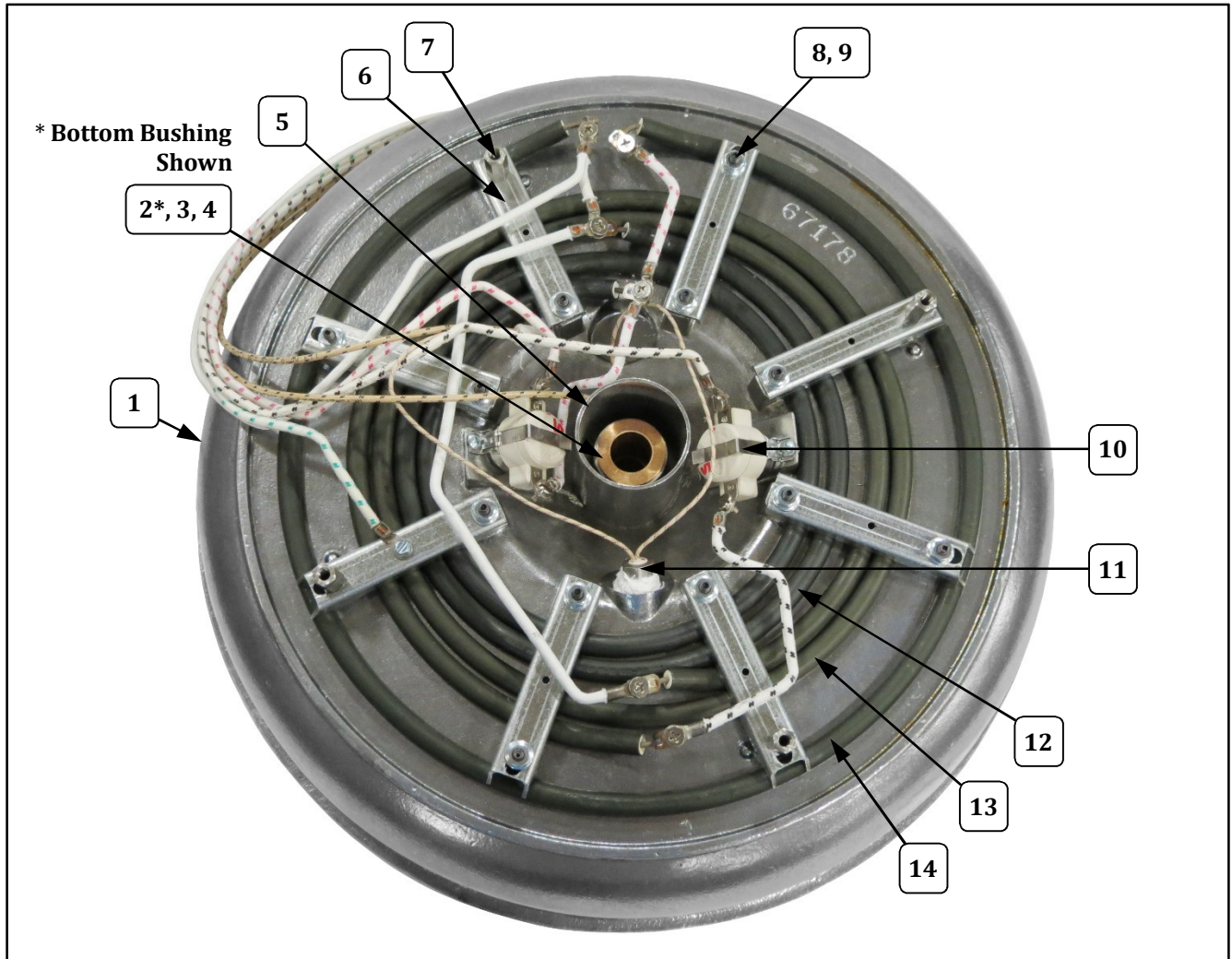

Item	Part Description	Part No.
		2175ER 2175ER
1	KETTLE, CORN TREAT CENTER (includes bushings shown below)	46280
2	BUSHING, MIX BOWL (bottom bushing shown)	46065PMO
3	BUSHING, MIX BOWL (top bushing not shown; bushing is machined to fit o-ring listed below)	46065
4	O-RING BUSHING SEAL	46119
5	SHAFT COVER	12581
6	ELEMENT RETAINER BRKT	67174
7	STANDOFF 11/16 IN	12889
8	SET SCREW 10-24 X 1	46627
9	10-24 SERRATED LOCK NUT	49363
10	L-510 THERMOSTAT KETTLE (2 required)	82219
11	RTD HEAT SENSOR	46299
12	TUBULAR ELEMENT, 720W	55279
13	TUBULAR ELEMENT, 1500W	48800
14	HEAT ELEMENT 120V 1000W	41536



Control Panel – Parts Breakdown

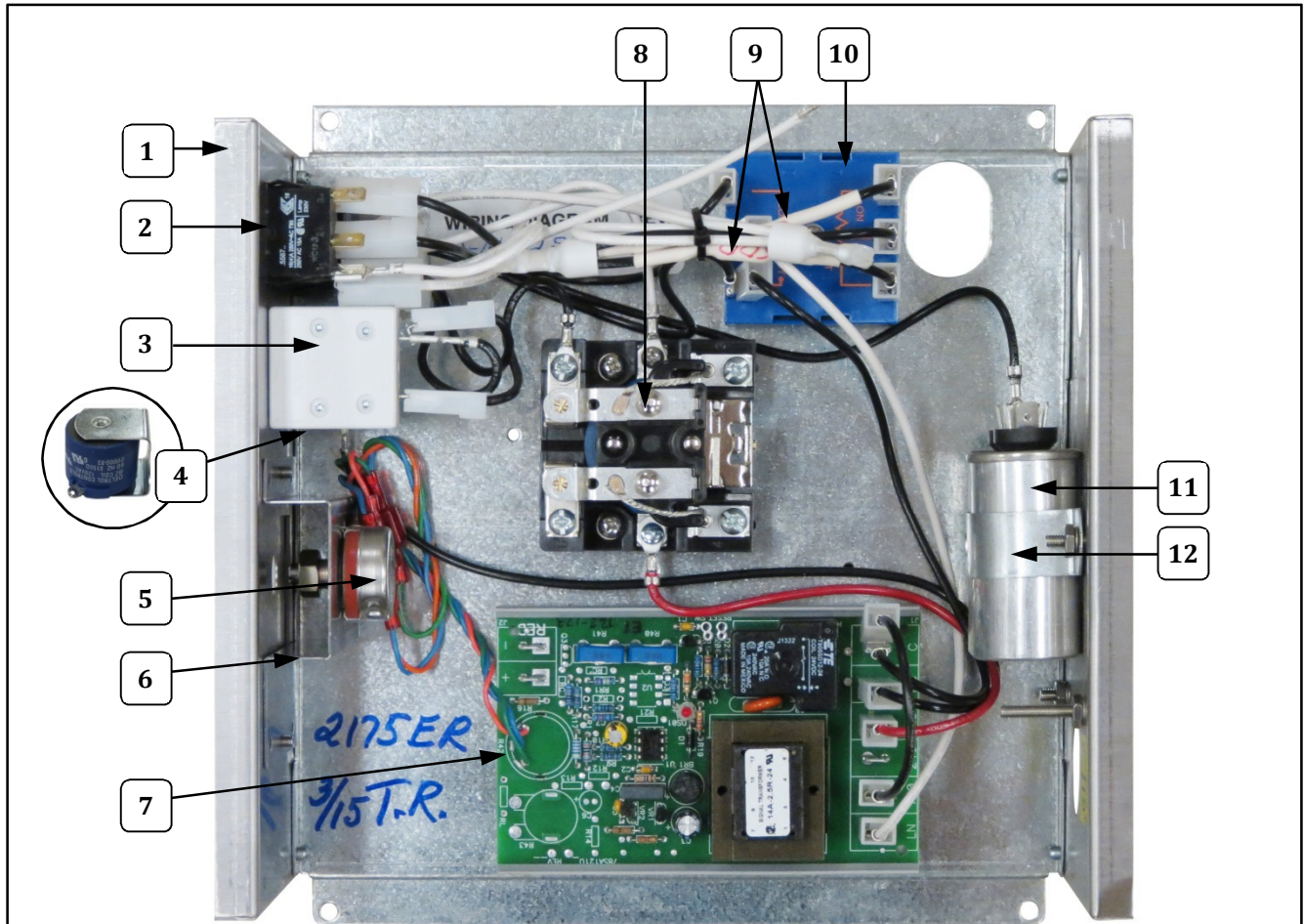

**Control Panel Interior
(Model 2175ER shown)**

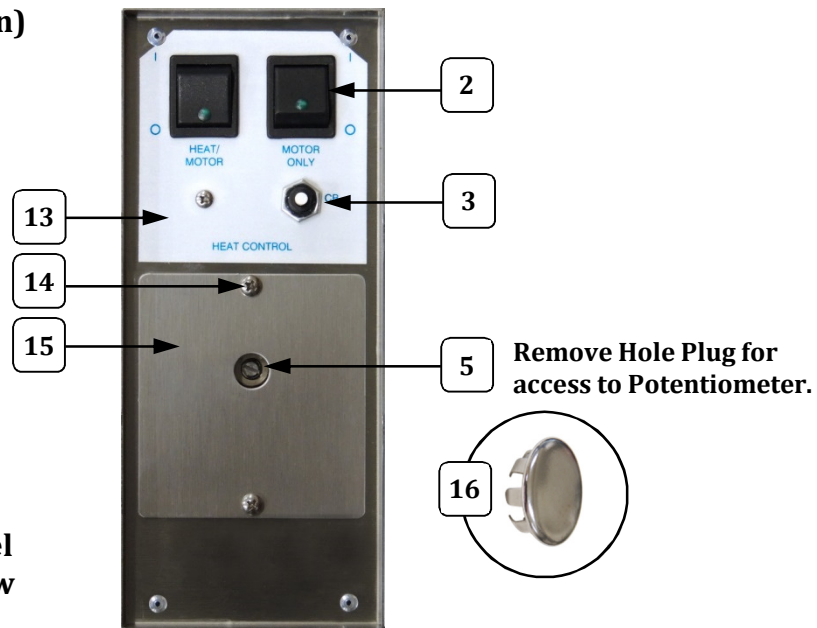

**Control Panel
Exterior View**



Digital Control Panel – Parts Breakdown

Item	Part Description	Part No.
		All Models
1	CONTRL BOX ASSY (includes support and cover)	55113
2	SWITCH, ROCKER DPDT LGHT	48616
3	CIRCUIT BREAKER, 15 AMP	47364
4	BUZZER SIGNAL	46118
5	POTENTIOMETER, 500 OHM	46326
6	POTENTIOMETER BRACKET	55471
7	TEMPERATURE CONTROL, RTD	55057
8	RELAY, 30A DPST 120V	55219
9	RESISTOR, 500K 1 WATT (2 required)	55009
10	TIMER, PERCENTAGE 60 SEC	48688
11	7.5 MFD CAPACITOR	46107
12	CAPACITOR STRAP	48301
13	OVERLAY, CONTROL BOX	55115
14	8-32 X 3/8 PAN HD PH M/S	12389
15	POTENTIOMETER COVER	55472
16	HOLE PLUG, 1/2 DIA. SS	45395

Safety Labels

Unit Labels

Power Cord Label

Item	Part Description	Part No.
		All Models
1	COOKER LABEL	111031
2	CAUTION HOT LABEL	38201
3	MINIMUM CLEARANCE LABEL	88720
4	MAIN GROUND LABEL	42375
5	WARNING LABEL CORD	68720



Accessories

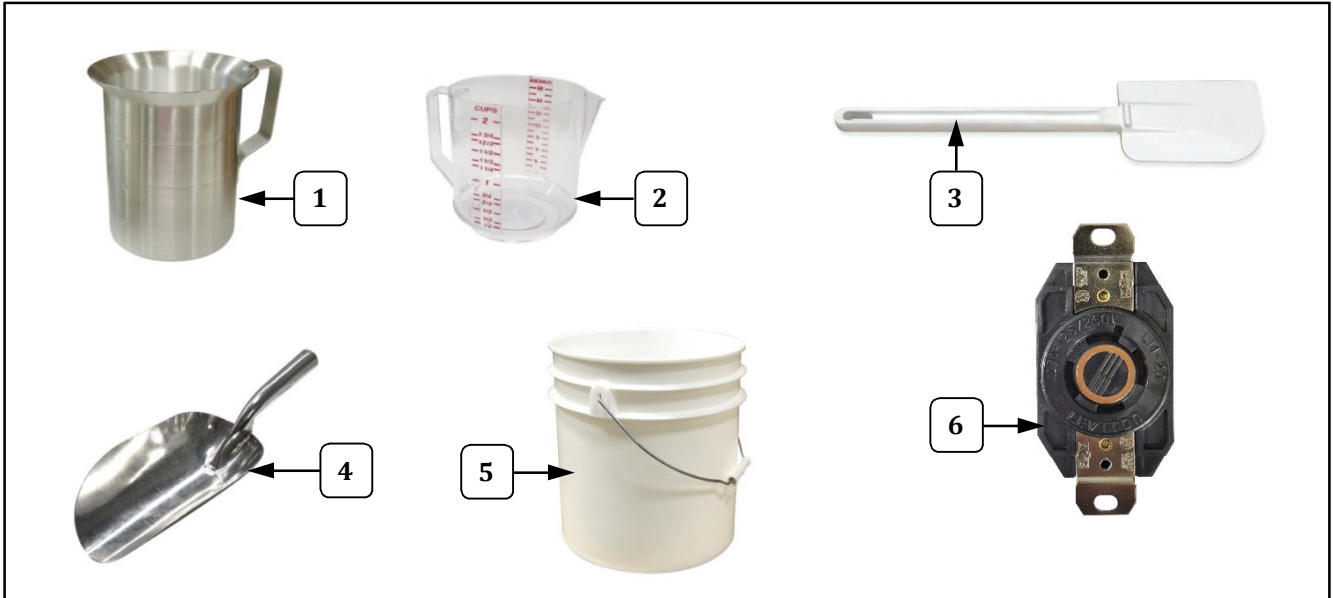

Item	Part Description	Part No.	
		2174EL 2174ER	2175EL 2175ER
1	ONE QUART MEASURE	46466	46466
2	2 CUP ACRYLIC MEASURE	62807	62807
3	BOWL SCRAPER	46210	46210
4	STAMPED ALUM SCOOP	2071	2071
5	5GAL WHITE STORAGE BUCKET	46125	46125
6	RECPT, 20A-125/250 VOLT		41254



Model No. 2175EL, 2175ER

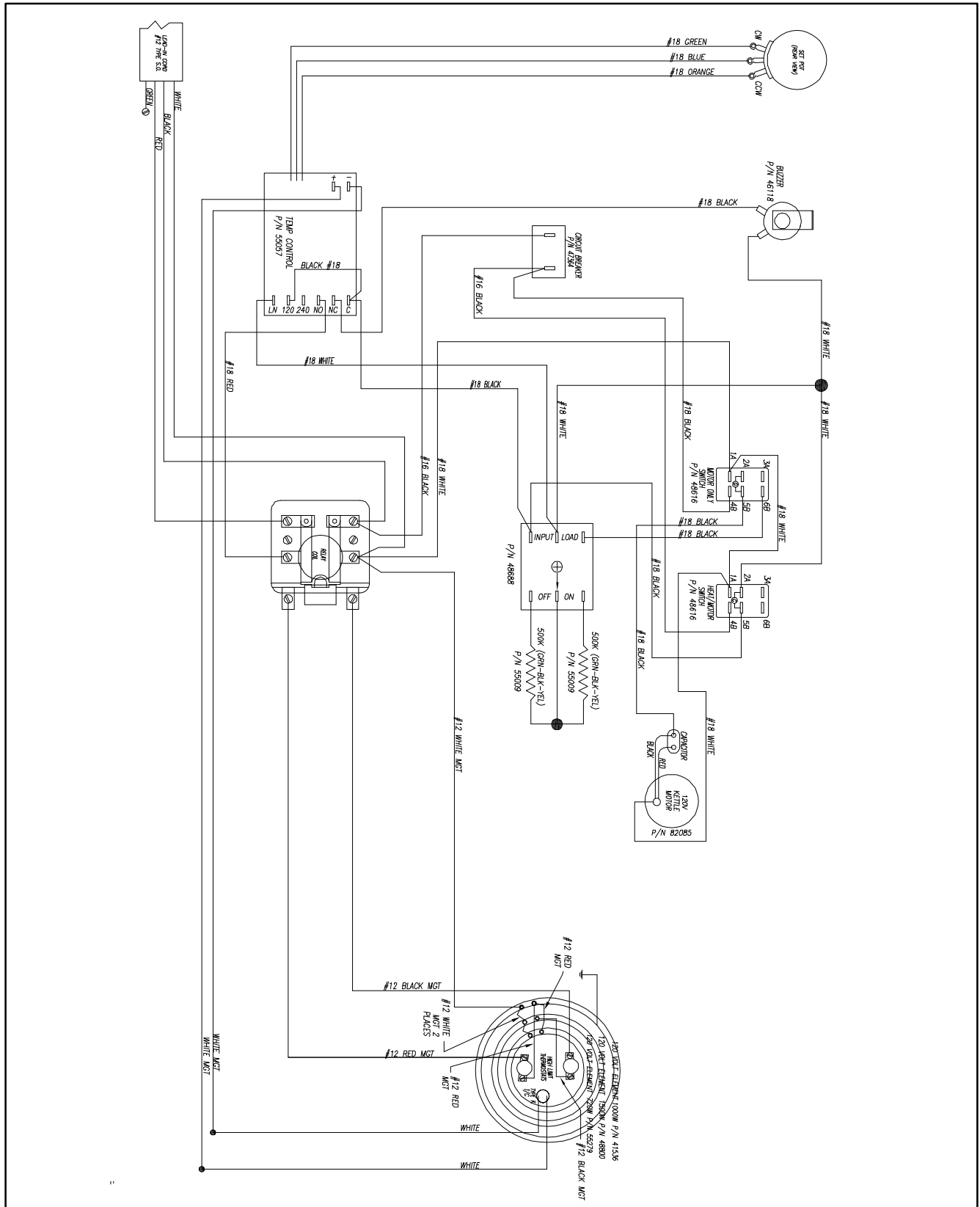



WARRANTY

Gold Medal Products Co. warrants to the original purchaser each item of its manufacture to be free of defects in workmanship and material under normal use and service. Gold Medal Products Co.'s obligation under this warranty is limited solely to repairing or replacing parts, f.o.b. Cincinnati, Ohio, which in its judgment are defective in workmanship or material and which are returned, freight prepaid, to its Cincinnati, Ohio factory or other designated point. Except for "Perishable Parts" on specific machines, the above warranty applies for a period of two (2) years from the date of original sale to the original purchaser of equipment when recommended operating instructions and maintenance procedures have been followed. These are packed with the machine. Parts warranty is two (2) years, labor is six (6) months.

THIS WARRANTY IS IN LIEU OF ALL OTHER WARRANTIES EXPRESSED OR IMPLIED, AND OF ALL OTHER OBLIGATIONS OR LIABILITIES ON OUR PART, INCLUDING THE IMPLIED WARRANTY OF MERCHANTABILITY. THERE ARE NO WARRANTIES WHICH EXTEND BEYOND THE DESCRIPTION ON THE FACE HEREOF. In no event shall Gold Medal Products Co. be liable for special, incidental or consequential damages. No claim under this warranty will be honored if the equipment covered has been misused, neglected, damaged in transit, or has been tampered with or changed in any way. No claim under this warranty shall be honored in the event that components in the unit at the time of the claim were not supplied or approved by Gold Medal Products Co. This warranty is effective only when electrical items have been properly attached to city utility lines only at proper voltages. This warranty is not transferable without the written consent of Gold Medal Products Co.

The term "Original Purchaser" as used in this warranty shall be deemed to mean that person, firm, association, or corporation who was billed by the GOLD MEDAL PRODUCTS CO., or their authorized distributor for the equipment.

THIS WARRANTY HAS NO EFFECT AND IS VOID UNLESS THE ORIGINAL PURCHASER FIRST CALLS GOLD MEDAL PRODUCTS CO. AT 1-800-543-0862 TO DISCUSS WITH OUR SERVICE REPRESENTATIVE THE EQUIPMENT PROBLEM, AND, IF NECESSARY, FOR INSTRUCTIONS CONCERNING THE REPAIR OR REPLACEMENT OF PARTS.

NOTE: This equipment is manufactured and sold for commercial use only.



GOLD MEDAL[®] PRODUCTS CO.

10700 Medallion Drive, Cincinnati, Ohio 45241-4807 USA

gmpopcorn.com

Phone: (800) 543-0862 Fax: (800) 542-1496
(513) 769-7676 (513) 769-8500

© 2015 – The text, descriptions, graphics, layout, and other material in this publication are the exclusive property of Gold Medal Products Co. and shall not be used, copied, reproduced, or published in any fashion, including website display, without its express written consent.