



Instruction Manual

RH & LH Digital Mark 10 Corn Treat Units

Model No. 2410 Series



GOLD MEDAL® PRODUCTS CO.

10700 Medallion Drive, Cincinnati, Ohio 45241-4807 USA





Table of Contents

SAFETY PRECAUTIONS	3
INSTALLATION INSTRUCTIONS	5
Inspection of Shipment	5
Manual	5
Model Description	5
Items Included with this Unit	5
Setup	6
Paddle and Drum Assembly	6
Electrical Requirements	7
Before You Plug In Machine	8
OPERATING INSTRUCTIONS	9
Controls and Their Functions	9
Adjusting the Set Temperature	10
Making Caramel Corn	11
Care and Cleaning	12
Kettle Cleaning Procedure	12
Daily Unit Cleaning Procedure	13
Weekly Cleaning of the Hub Seal Assembly	13
Troubleshooting	15
—THE FOLLOWING SECTIONS ARE FOR QUALIFIED SERVICE PERSONNEL ONLY—.....	16
MAINTENANCE INSTRUCTIONS	16
New Paddle/Hub Seal Kit Installation	17
Kettle Shaft Maintenance	17
ORDERING SPARE PARTS.....	18
Cabinet Exterior and Handle Assembly	19
Kettle and Drum – Parts Breakdown	21
Kettle Bottom – Parts Breakdown	23
Control Box Interior and Exterior	25
Safety Labels.....	26
Accessories	26
Wiring Diagram	27
WARRANTY.....	28





SAFETY PRECAUTIONS

	⚠ DANGER
	<p>Machine must be properly grounded to prevent electrical shock to personnel. Failure to do so could result in serious injury, or death. Make sure all machine switches are in the OFF position before plugging the equipment into the receptacle. Keep cord and plug off the ground and away from moisture. Always unplug the equipment before cleaning or servicing. DO NOT immerse any part of this equipment in water. DO NOT use a water jet or excessive water when cleaning.</p> <p>008_012221</p>

	⚠ DANGER
	<p>Improper installation, adjustment, alteration, service, or maintenance can cause property damage, injury, or death. Any alterations to this equipment will void the warranty and may cause a dangerous condition. This appliance is not intended to be operated by means of an external timer or separate remote-control system. NEVER make alterations to this equipment. Read the Installation, Operating, and Maintenance Instructions thoroughly before installing, servicing, or operating this equipment.</p> <p>014_020416</p>



	⚠ WARNING
	<p>To avoid burns, DO NOT touch the kettle or any heated surface. DO NOT place or leave objects in contact with heated surfaces.</p> <p>013_092414</p>

	⚠ WARNING
	<p>ALWAYS wear safety glasses when servicing this equipment.</p> <p>010_010914</p>

	⚠ WARNING
	<p>No user serviceable parts inside. Refer servicing to qualified service personnel.</p> <p>011_051514</p>

	⚠ WARNING
	<p>Read and understand operator's manual and all other safety instructions before using this equipment. To order copies of the operator's manual go to gmpopcorn.com or write to Gold Medal Products Co., 10700 Medallion Drive, Cincinnati, OH 45241 USA 1-(800)-543-0862</p> <p>022_060215</p>



	 WARNING
	DO NOT allow direct contact of this equipment by the public when used in food service locations. Only personnel trained and experienced in the equipment operation may operate this equipment. Carefully read all instructions before operation. 012_010914

	 WARNING
	This machine is NOT to be operated by minors. 007_010914

	 CAUTION
	If the supply cord is damaged, it must be replaced by Gold Medal Products Co., its service agent or similarly qualified persons in order to avoid a hazard. 039_080614

Note: Improvements are always being made to Gold Medal's equipment. This information may not be the latest available for your purposes. It is critical that you call Gold Medal's Technical Service Department at 1-800-543-0862 for any questions about your machine operations, replacement parts, or any service questions. (Gold Medal Products Co. does not assume any liability for injury due to careless handling and/or reckless operation of this equipment.) General images may be used in manual for reference only.



INSTALLATION INSTRUCTIONS

Inspection of Shipment

After unpacking, check thoroughly for any damage which may have occurred in transit. Claims should be filed immediately with the transportation company. The warranty does not cover damage that occurs in transit, or damage caused by abuse, or consequential damage due to the operation of this machine, since it is beyond our control (reference warranty in back of manual).

Manual

Read and understand the operator's manual and all other safety instructions before using this equipment. To order copies of the operator's manual go to gmpopcorn.com or write to Gold Medal Products Co., 10700 Medallion Drive, Cincinnati, OH 45241 USA 1-(800)-543-0862.

Model Description

Digital Mark 10 Corn Treat Unit:

- 10 gallon capacity
- Either right hand or left hand dump capability
- Either straight handle or upright handle—upright handle model mounts on a 2436-001 short base (sold separately) when used with a 2169 series lift table (sold separately.)

2410-00-100: Right hand dump, straight handle

2410-00-110: Left hand dump, straight handle

2410-00-102: Right hand dump, upright handle

2410-00-112: Left hand dump, upright handle

Items Included with this Unit





Setup

1. Remove all packaging and tape, and accessories before starting operation.
2. This unit must be properly fastened to a sturdy counter or base, see illustration below for mounting requirements.

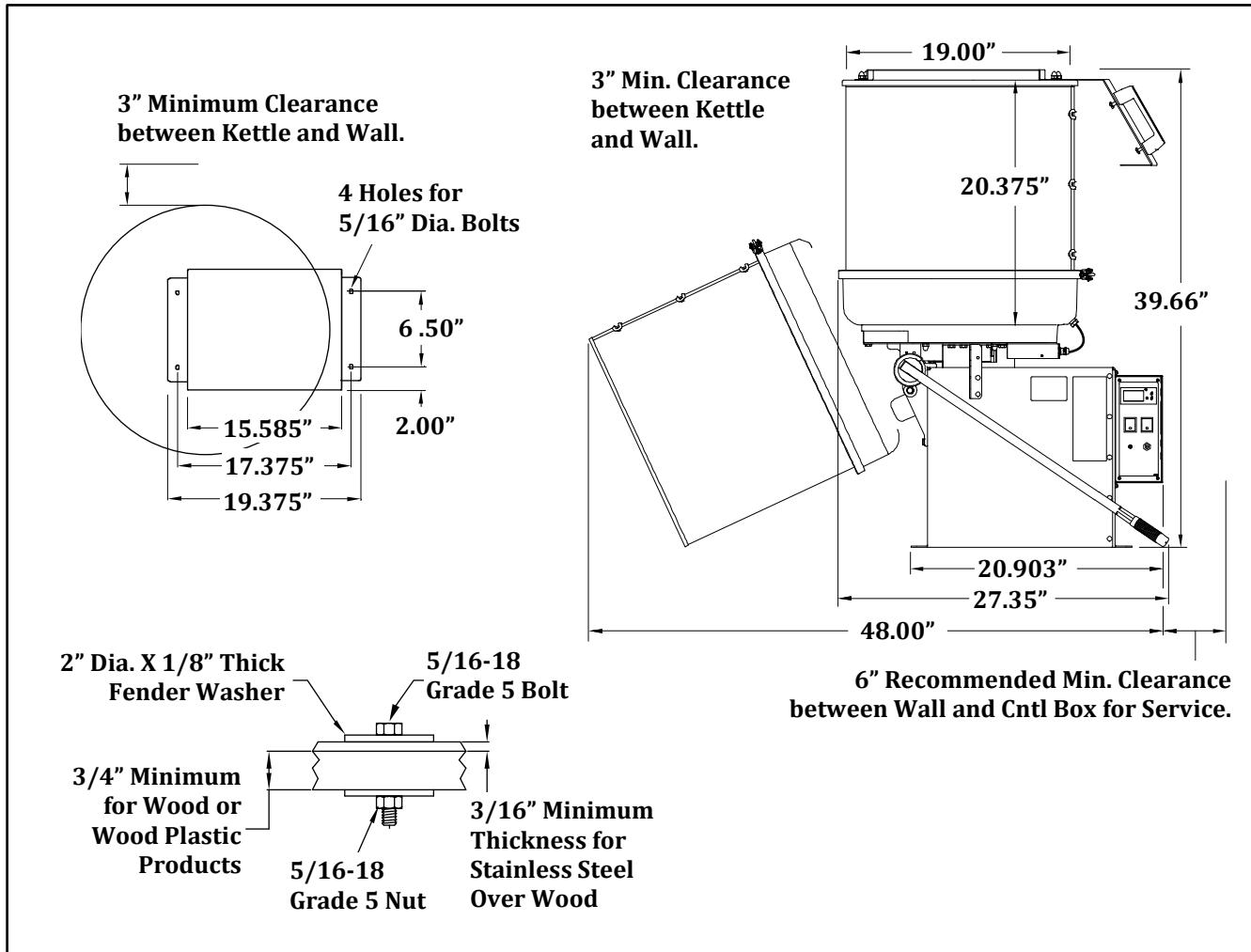

Paddle and Drum Assembly

1. Prior to operation, rotate the top paddle from the shipping position into the mix position—reference images on next page for paddle and drum assembly:
 - a) Pull plunger knob out and lift paddle into position.
 - b) When positioned, release knob and make sure the plunger securely sets into its hole in the shaft to lock the paddle in place.
2. After setup, the unit should be cleaned prior to use (see Care and Cleaning section).



Fasten or Adjust Retaining Ring Latch

1. Open latch then fit retaining ring over drum and kettle rims.
2. Place hook in first slot.
3. Push clasp tight to kettle to lock retainer in place.
4. To adjust hook length, loosen nut, adjust hook in or out, then retighten nut.

Electrical Requirements

The following power supply must be provided (reference unit Data Plate for Wattage requirement):

120/208 or 120/240 V~, 60 Hz

Unit is designed to operate on single phase, 30 AMP, 4 wire supply, 120/208 or 120/240 V~ (2 Hot, 1 Neutral, 1 Ground). All electrical components in this machine are 120 V (motors, heat elements, lights, etc.) and therefore require "Hot to Neutral" connection (**NOT** "Hot to Hot"). A wall receptacle is supplied with the machine. This receptacle will accept the attachment plug on the machine and must be used.

	DANGER
	<p>Machine must be properly grounded to prevent electrical shock to personnel. Failure to do so could result in serious injury, or death. Make sure all machine switches are in the OFF position before plugging the equipment into the receptacle. Keep cord and plug off the ground and away from moisture. Always unplug the equipment before cleaning or servicing. DO NOT immerse any part of this equipment in water. DO NOT use a water jet or excessive water when cleaning.</p> <p style="text-align: right; font-size: small;">008_012221</p>

A certified electrician must furnish sufficient power for proper machine operation and install any supplied receptacle (reference unit Data Plate for model specific Volts AC, Hertz, and Wattage

requirements). We recommend this equipment be on a dedicated and protected circuit. Failure to wire properly will void the warranty and may result in damage to the machine. It is Gold Medal Products Co.'s recommendation that this machine be plugged directly into a wall outlet. The use of extension cords is not recommended due to safety concerns, and may cause sacrificed and/or reduced performance. Make sure cord is located to prevent a trip hazard or unit upset.

Receptacle Installation for L14-30

A certified electrician must follow the IMPORTANT instructions below for installation of the L14-30 Receptacle (Gold Medal Item No. [82208](#)) provided with the unit.

If the receptacle is wired incorrectly, the heat elements/kettle and other electrical components could be at 208 or 240 V potential instead of the needed 120 V, resulting in excessive temperatures in the heat elements (i.e.: kettle) and possible fire, and/or damage to electrical components.

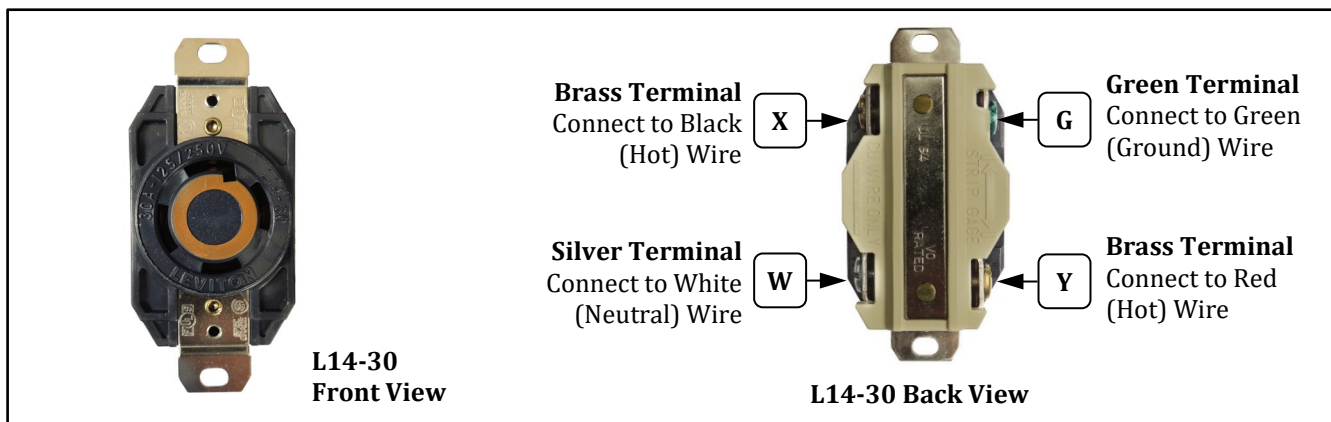

Before You Plug In Machine

1. Make sure all machine switches are OFF before plugging in equipment into receptacle.
2. Make sure wall outlet can accept the grounded plugs (where applicable) on the power supply cord.
3. The wall outlet must have the proper polarity. If in doubt, have a competent electrician inspect the outlet and correct if necessary.
4. **DO NOT** use a grounded to un-grounded receptacle adapter (where applicable).
5. Install unit in a level position.

	CAUTION
	If the supply cord is damaged, it must be replaced by Gold Medal Products Co., its service agent or similarly qualified persons in order to avoid a hazard.

039_080614



OPERATING INSTRUCTIONS

Controls and Their Functions

HEAT/MOTOR SWITCH

ON/OFF lighted rocker switch – provides power to the heating elements in the bottom of the kettle and powers the agitator motor to turn for 30 seconds of every minute. The green switch light ON indicates there is power to these features.

Note: It is normal for the motor to stop for 30 seconds of every minute (when the Motor Only Switch is OFF).

MOTOR ONLY SWITCH

ON/OFF lighted rocker switch – provides power to the agitator motor to run continuously.

Note: The main function of the Motor Only switch is to mix the popcorn at the end of the cooking cycle (with the kettle in the mix position); and it is used for “cleaning mode”.

CIRCUIT BREAKER

The Circuit Breaker protects the Motor and Heat Control from an overload condition.

KETTLE DUMP HANDLE

The Kettle Dump Handle tilts the kettle from the upright cook position, to the mix position or the dump position. The 2 position bracket holds the handle in the tilted position.

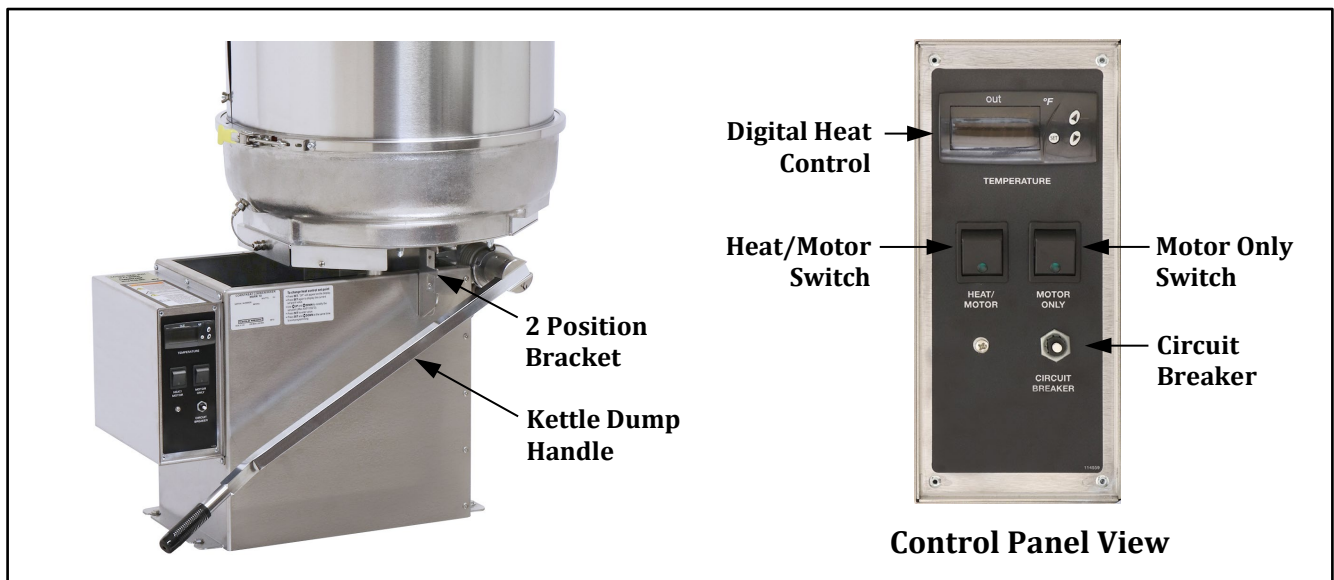

DIGITAL HEAT CONTROL

The Digital Heat Control displays kettle temperature and is used to adjust the set point temperature—unit is factory preset at 275°F (135°C). See Adjusting the Set Temperature section to change the set point.

The buzzer sound signals kettle heat shut-off. The buzzer will continue to sound until unit is turned off or until unit temperature falls below set point.



Adjusting the Set Temperature

The Digital Heat Control is factory preset at 275°F (135°C); maximum setting is 450°F (232°C).

The set point temperature you need may vary from the preset temperature depending on your recipe and cooking environment. Use the preset as a starting point, then adjust it to fit your needs.

To adjust the preset temperature:

1. Press “SET” button on the Digital Heat Control, and “SP” will appear. Press “SET” again to display current set temperature.
2. Press the “UP/DOWN” arrows to adjust to the desired temperature. Press “SET” to save.
3. Press “SET” and the “DOWN” arrow at the same time to return to operating mode.

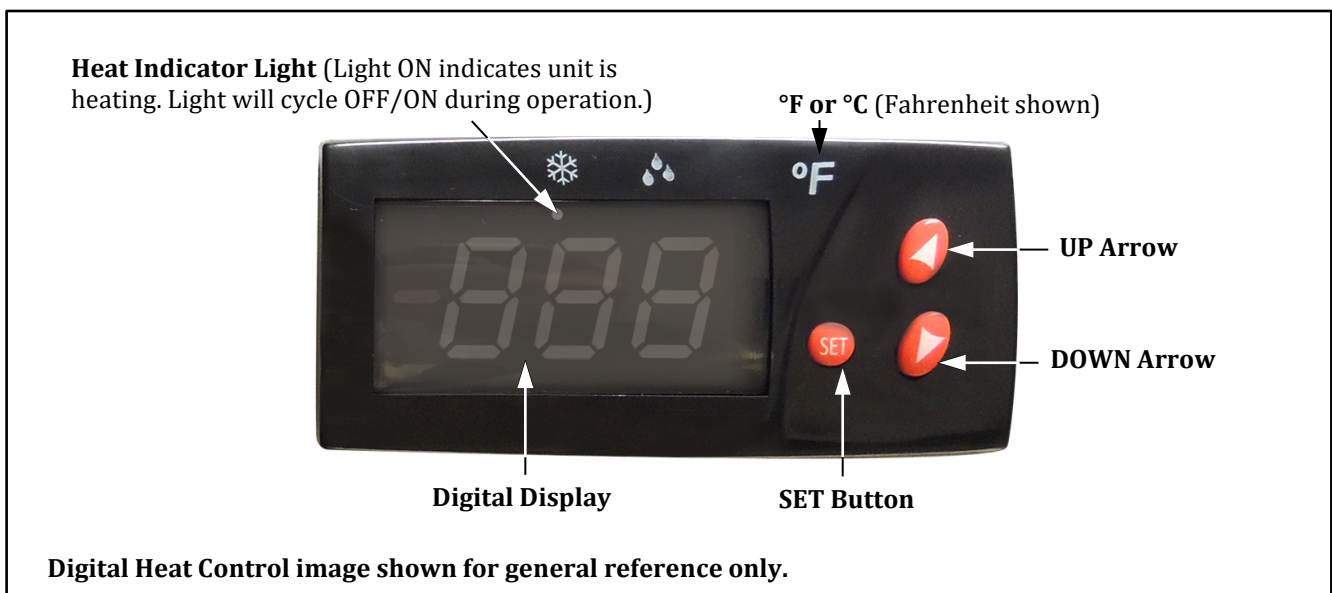



Making Caramel Corn

Always remember—leave the lid on the kettle during the first part of the batch. Once steam starts to “roll-up” from under the lid, carefully remove the lid for remainder of the cooking cycle.

CAUTION: Beware of rising steam; keep face and hands clear of rising steam.

The set point temperature you need may vary from the preset temperature depending on your recipe and cooking environment. Use the preset as a starting point, then adjust it to fit your needs.

1. Turn Heat/Motor Switch ON (leave Motor Only Switch OFF).
2. Add (2) 22 oz. packages of Gold Medal Caramel Corn Mix (Item No. 2094), 8 cups of granulated sugar (brown or white), and 16–22 oz. of water (add water last).
Note: If using Gold Medal “One Step” Caramel Corn Mix, **DO NOT** add granulated sugar.
3. Turn Motor Only Switch ON—mix approx. 1 minute, then turn Motor Only Switch OFF.
(With the Heat/Motor Switch still ON—motor will run for 30 sec. of every minute.)
4. Add 8 oz. of coconut oil or vegetable oil. Put on the lid.
Note: Once steam starts to “roll-up” from under the lid, carefully remove lid for remainder of cooking cycle.
5. Allow mix to cook until buzzer sounds.
Note: Product temperature can be measured with a candy thermometer.
6. Turn Heat/Motor Switch OFF.
7. Turn Motor Only Switch ON.
8. Add 10 gallons of pre-popped corn.
9. Allow corn to mix for approx. 10 seconds with kettle in upright position.
10. Move kettle to mix position and spray 10–15 “squirts” of Gold Medal Free-N-Easy (Item No. 2250) on caramel corn to help separation—mix popcorn until thoroughly coated.
11. Dump caramel corn into a cooling pan—mix and separate the caramel corn using two popcorn scoops.
12. After dumping, turn Motor Only Switch OFF.
13. Allow finished product to cool before packaging.

During normal operation, sugar builds up in the kettle and it must be removed (reference Kettle Cleaning Procedure in the Care and Cleaning section.):

- Steam the kettle every 3–4 batches to remove sugar build-up.
- Steam the kettle after making single batches if unit is turned off between batches.
- **Steam the kettle before turning unit off for the day.**



Care and Cleaning

	⚠ DANGER
	Machine must be properly grounded to prevent electrical shock to personnel. DO NOT immerse in water. DO NOT clean appliance with a water jet or steam cleaner. Always unplug the equipment before cleaning or servicing. 025_051321

	⚠ WARNING
	To avoid serious burns, DO NOT touch the kettle while it is hot! 028_082715

Good sanitation practice demands that all food preparation equipment be cleaned regularly—only use non-toxic, food grade cleaners.

For surfaces needing further cleaning or degreasing, Watchdog Stainless Cleaner (Item No. 2088) or Watchdog Concession Equipment Degreaser (Item No. 2580) is available for use accordingly. For any cleaning products used, follow the manufacturer's instructions on the product. **DO NOT use oven cleaners or abrasive materials** as they will damage parts of machine.

Note: It is extremely important to follow all cleaning procedures, otherwise parts damage and equipment failure will result. The warranty does not cover parts that are damaged due to improper cleaning.

Kettle Cleaning Procedure

Follow procedure below to steam sugar build-up out of the kettle every 3-4 batches during regular operation and before turning the unit off for the day. Steam kettle out **after every batch** if the unit is turned off between batches.

1. After all product has been removed and the kettle has cooled 15-20 minutes, carefully pour 24 oz. of water into kettle.

CAUTION: Beware of rising steam; keep face and hands clear of rising steam.

2. Place lid on kettle and turn Heat/Motor Switch ON.
3. When water starts to boil, turn Heat/Motor Switch OFF.
4. Turn Motor Only Switch ON and allow unit to cool, then remove lid and carefully pour kettle contents into a pan/bucket. Steam kettle twice to help remove all traces of product.
5. Turn Motor Only Switch OFF.
6. With all switches OFF, wipe out any sugar build-up remaining in kettle using a clean damp rag, then kettle is ready to begin another batch.
7. Do not leave water in kettle or pan overnight—clean pans/bucket for next use.



Daily Unit Cleaning Procedure

1. Turn machine OFF, unplug the unit and allow it to cool before attempting to clean.
2. Clean all pans/accessories after each use.
3. Release draw latch and remove mixing drum, then remove paddles (pull plunger knob and lift paddle off).

Take drum and paddles to sink and clean with soap and water, then rinse and dry.

4. With unit OFF and unplugged, use a clean SLIGHTLY damp cloth (wring ANY EXCESS water from cloth before use) and wipe the kettle lead cord clean. **DO NOT get moisture into the kettle lead-in cord, severe damage will result.**
5. Wipe unit clean using a cloth SLIGHTLY dampened with soap and water, then wipe again to remove any remaining cleaner.
6. The bottom kettle bushing is slotted to help drain residue if it passes the hub seal—a silicon washer protects the motor from drainage so check and clean the area as follows:
 - a. Put kettle in dump position.
 - b. Check shaft area under kettle and check silicone washer for sugar residue.
 - c. Wipe off any dripping or sticky residue from the shaft area and silicone washer using a SLIGHTLY damp cloth—wring ANY EXCESS water from cloth before use. **DO NOT get moisture into the motor, severe damage will result.**
 - d. Make sure silicone washer is free to turn with motor shaft—damaged or missing silicone washer must be replaced.

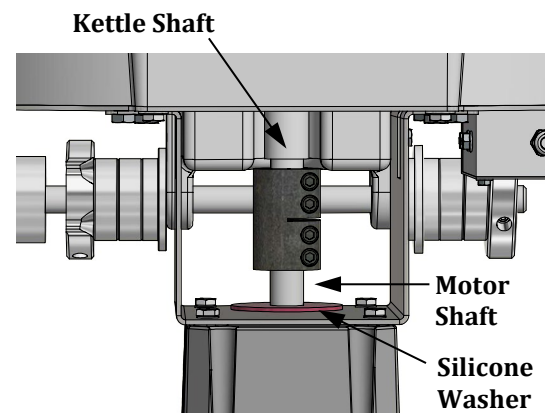

Tilt Kettle to Access Shafts

Weekly Cleaning of the Hub Seal Assembly

Important: Keep the hub seal and o-rings clean for proper machine performance.

1. Turn machine OFF, unplug the unit and allow it to cool.
2. Pull knurled knob of plunger and lift mix paddles off shaft.
3. Remove any burrs on the shaft using a fine grit emery paper to lightly sand the surface—burrs can damage the o-ring/oil seal during removal/installation.
4. Remove the hub seal assembly and soak it in hot water to clean.
5. Clean out any sanding partials from kettle and shaft.
6. Clean the area around the center hub. Remove any product residue. (See Kettle Shaft Maintenance section for note on lubricating the kettle bushings.)



7. Lightly lubricate the center hub of the kettle with a small amount of Petro Gel to allow for easy re-installation of the hub seal assembly.
8. Slide the clean hub seal assembly down the agitator shaft. Apply pressure to ease the assembly over the center hub of the kettle until it seats properly.
9. Re-install the mix paddles—make sure the plunger of each paddle securely sets into its hole in the shaft.

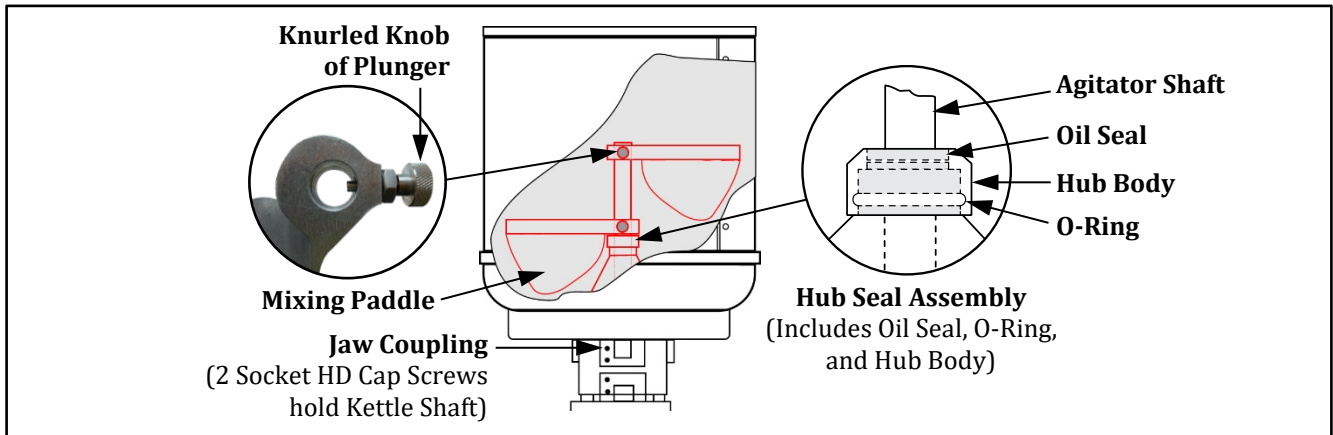





Troubleshooting



Issue	Possible Cause	Solution
Kettle Does Not Heat	<p>A. Power to Unit</p> <p>B. Circuit Breaker</p> <p>C. Kettle Heat/Motor Switch</p> <p>D. Control</p>	<p>A. Make sure the unit lead-in cord is plugged in.</p> <p>B. Check the condition of the circuit breaker. The breaker may trip during transit, if reset and trips again, contact qualified service personnel for inspection/repair before going any further.</p> <p>C. Have qualified service personnel check the voltage to and from the Heat/Motor Switch; if switch is defective, replace it.</p> <p>D. A defective sensor lead will cause the kettle not to heat. Have qualified service personnel check for good connections from the kettle to the control.</p>
Kettle Agitator Does Not Turn	<p>A. Kettle Agitator Shaft/Motor Shaft</p>	<p>A. If the kettle agitator shaft is not rotating, DO NOT use. Have qualified service personnel inspect/repair as needed.</p>
Long Cooking Cycles	<p>A. Heating Element</p> <p>B. Low Voltage</p> <p>C. Inadequate Supply Lines</p>	<p>A. One of the heating elements in the kettle may be burned out. This would result in the kettle never reaching the proper operating temperature. Contact qualified service personnel for inspection/repair.</p> <p>B. Unit is designed to make approximately 3 batches per hour when operated at full voltage. To get unit warmed up, the first batch usually takes about 5 minutes longer. If machine is operated on low voltage, the kettle will not reach the proper operating temperature causing longer cooking cycles. 120 V units need a 105 V minimum.</p> <p>C. Inadequately sized electrical supply lines, in addition to being a fire hazard, would also prevent the kettle from reaching the proper operating temperature. Check with a qualified electrician.</p>
Mix Burns	<p>A. Set Temperature</p> <p>B. Mix Paddle set too high</p>	<p>A. Adjust set temperature as needed, reference Adjusting the set Temperature section.</p> <p>B. If the bottom paddle sets too high from the cooking surface, the mix will not stir properly and can burn. The agitator shaft must be adjusted so the paddle will stir the mix, but not touch the kettle bottom. Have qualified service personnel reference the Maintenance Instruction section.</p>







—THE FOLLOWING SECTIONS ARE FOR QUALIFIED SERVICE PERSONNEL ONLY—

MAINTENANCE INSTRUCTIONS

	 DANGER
	<p>Machine must be properly grounded to prevent electrical shock to personnel. Failure to do so could result in serious injury, or death. Make sure all machine switches are in the OFF position before plugging the equipment into the receptacle. Keep cord and plug off the ground and away from moisture. Always unplug the equipment before cleaning or servicing. DO NOT immerse any part of this equipment in water. DO NOT use a water jet or excessive water when cleaning.</p> <p>008_012221</p>

	 DANGER
	<p>Improper installation, adjustment, alteration, service, or maintenance can cause property damage, injury, or death. Any alterations to this equipment will void the warranty and may cause a dangerous condition. This appliance is not intended to be operated by means of an external timer or separate remote-control system. NEVER make alterations to this equipment. Read the Installation, Operating, and Maintenance Instructions thoroughly before installing, servicing, or operating this equipment.</p> <p>014_020416</p>

	 WARNING
	<p>No user serviceable parts inside. Refer servicing to qualified service personnel.</p> <p>011_051514</p>

	 CAUTION
	<p>THE FOLLOWING SECTIONS OF THIS MANUAL ARE INTENDED ONLY FOR QUALIFIED SERVICE PERSONNEL WHO ARE FAMILIAR WITH ELECTRICAL EQUIPMENT. THESE ARE NOT INTENDED FOR THE OPERATOR.</p> <p>027_010914</p>



New Paddle/Hub Seal Kit Installation Kettle Shaft Maintenance

1. With the machine OFF, unplug the unit and allow it to cool.
2. Pull knurled knob of plunger and lift mix paddles off shaft.
3. Remove any burrs on the shaft using a fine grit emery paper to lightly sand the surface—burrs can damage the o-ring/oil seal during removal/installation.
4. Remove the old hub seal assembly.
5. Clean any sanding partials from kettle and shaft.
6. Clean the area around the center hub. Remove any product residue.

Monthly Shaft Maintenance: Remove the kettle shaft monthly and lubricate the kettle bushings with white food grade Never Seez® **ONLY**, then reinstall the shaft.

To remove the shaft, loosen the 2 screws in the jaw coupling, then remove the kettle shaft. **DO NOT lose the shaft key, it must be reset into place.**

7. The bottom kettle bushing is slotted to help drain residue if it passes the hub seal—a silicon washer protects the motor from drainage so make sure the washer is in place and clean, see Daily Unit Cleaning in the Cleaning and Care section.
8. Lightly lubricate the center hub of the kettle with a small amount of Petro Gel to allow for easy installation of the hub seal assembly.
9. Slide the new hub seal assembly down the agitator shaft. Apply pressure to ease the assembly over the center hub of the kettle until it seats properly (see image below).
10. Re-install the mix paddles—make sure the plunger of each paddle securely sets into its hole in the shaft.
11. Rotate the shaft by hand to make sure the paddle does not touch the kettle bottom; re-adjust shaft if needed.

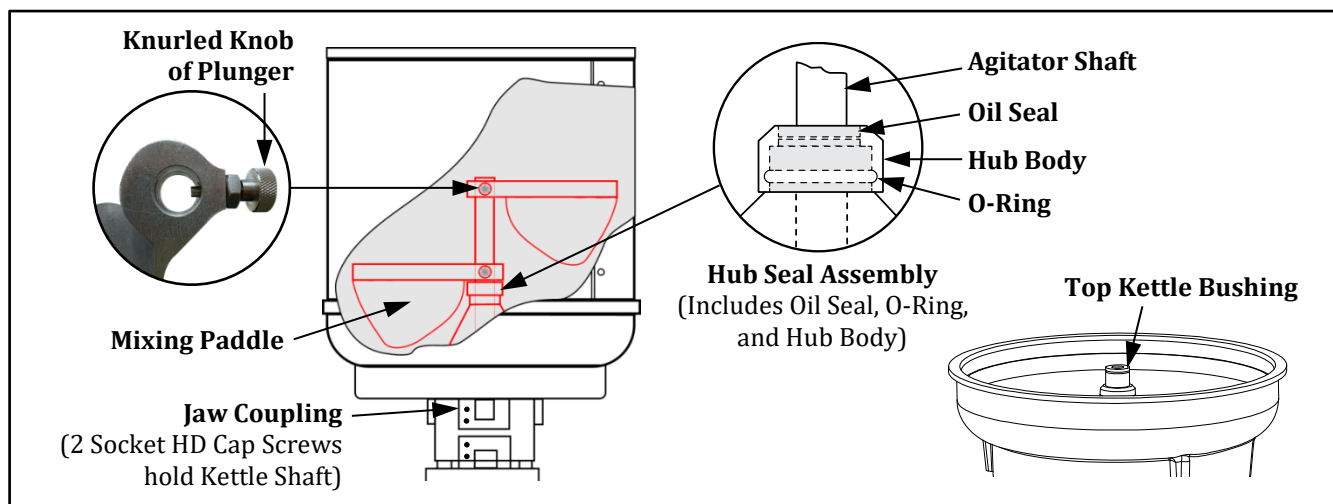



ORDERING SPARE PARTS

1. Identify the needed part by checking it against the photos, illustrations, and/or parts list. (General images may be used in manual for reference only.)
2. Use only approved replacement parts when servicing this unit.
3. When ordering, please include part number, part name, and quantity needed.
4. Please include your model number, serial number, and date of manufacture (located on the machine nameplate/data plate) with your order.
5. Address all parts orders to Parts Department, Gold Medal Products Co., 10700 Medallion Drive, Cincinnati, Ohio 45241-4807

or place orders by phone or online:

Phone: (800) 543-0862
(513) 769-7676

Fax: (800) 542-1496
(513) 769-8500

E-mail: info@gmpopcorn.com
Web Page: gmpopcorn.com



Cabinet Exterior and Handle Assembly

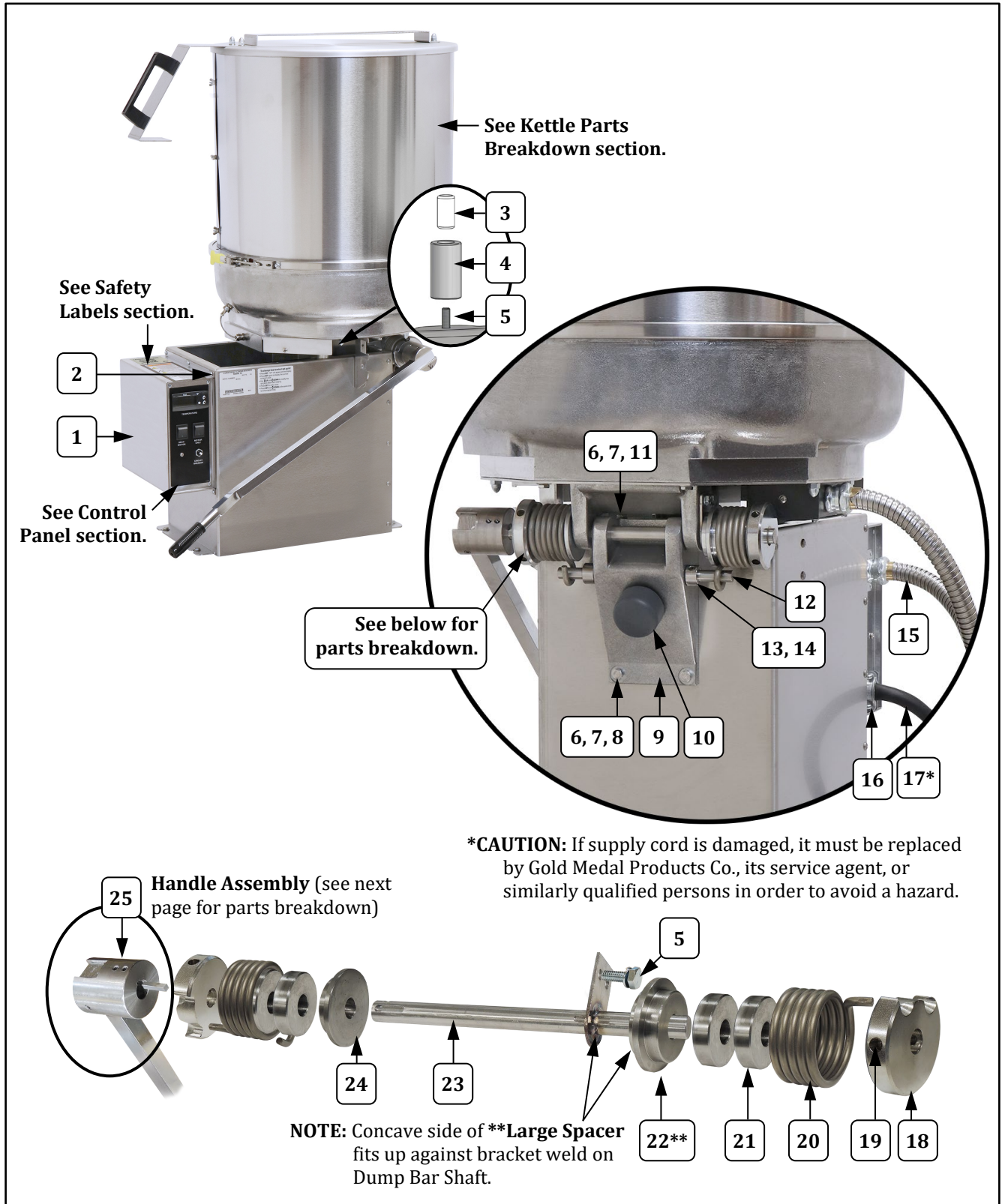

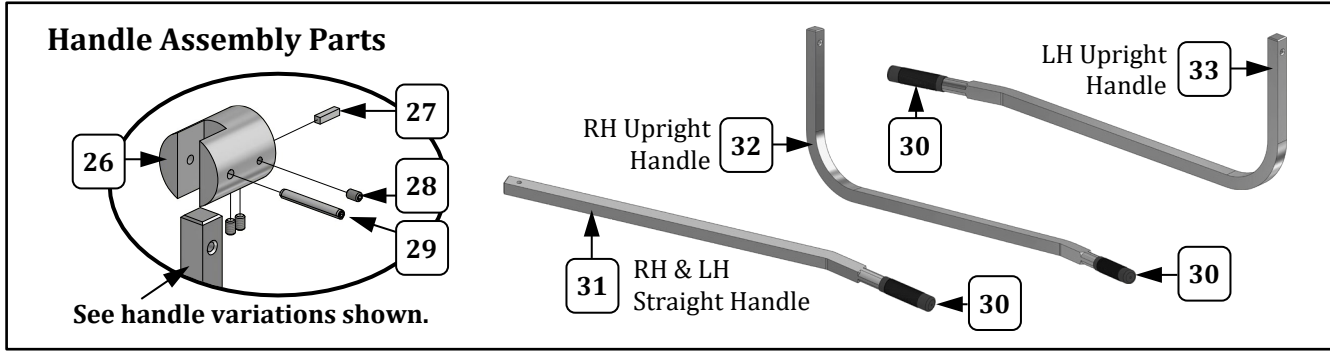

Item	Parts Description	Part Number			
		2410-00-100	2410-00-102	2410-00-110	2410-00-112
1	CONTROL BOX COVER	101478	101478	101478	101478
2	SCREW #8-32X3/8 PAN HD PH	74141	74141	74141	74141
3	KETTLE REST BUMPER (rubber bumper)	83111	83111	83111	83111
4	KETTLE REST (metal rest/holds rubber bumper)	83110	83110	83110	83110
5	1/4-20 X 3/4 GRADE 5 BOLT (fastens kettle rest)	74520	74520	74520	74520
6	1/4-20 X 3/4 HEX CAP 18-8	12515	12515	12515	12515
7	1/4 SPRING LOCK WASHER	12707	12707	12707	12707
8	1/4-20 SERRATED LOCK NUT (top side of bracket use a 1/4-20 ESLOK Hex Nut)	46311	46311	46311	46311
9	KETTLE MTNG BRKT MACHINED	48812	48812	48812	48812
10	KETTLE STOP	70047	70047	70047	70047
11	HEX NUT 1/4-20 ESLOK	42361	42361	42361	42361
12	SPRING RETAINER ROD	82551	82551	82551	82551
13	SET COLLAR 1/2ID X 7/8OD	47326	47326	47326	47326
14	SET SCREW 1/4-20 X 3/16	47751	47751	47751	47751
15	KETTLE LEAD IN ASSY (includes connectors)	46546	46546	46546	46546
16	STRAIN RELIEF T&B 3304	82227	82227	82227	82227
17*	LEAD-IN CORD ASSY	16050	16050	16050	16050
18	COLLAR	74661	74661	74661	74661
19	SET SCREW, 5/16-18 X 5/8 (3 req'd. per collar)	74662	74662	74662	74662
20	TORSION SPRING	74660	74660	74660	74660
21	SPACER	74658	74658	74658	74658
22**	SPACER,LARGE (DUMP SIDE)	74659	74659	74659	74659
23	RT DUMP BAR WELDMENT	48841		48841	
	LEFT DUMP SHAFT WELDMENT		48881		48881
24	SPACER,LARGE (CUSTOMER SIDE)	74690	74690	74690	74690
25	DUMP HANDLE ASSEMBLY (straight handle, includes parts listed below)	114658	114658		
	RH LOW PROFILE DUMP HANDLE ASSEMBLY (includes parts listed below)			114659	
	LH LOW PROFILE DUMP HANDLE ASSEMBLY (includes parts listed below)				114659L
26	HUB	48839	48839	48839	48839
27	KEY (.187 X .187 X 3/4)	12509	12509	12509	12509
28	SET SCREW 1/4-20 X 3/8	74125	74125	74125	74125
29	COILED SPRING PIN	48883	48883	48883	48883
30	GRIP, HANDLE BAR	46028	46028	46028	46028
31	TILT LEVER, MARK 10 CTC	46488	46488		
32	TILT LEVER LOW MNT CTC RH			101449	
33	TILT LEVER LOW MNT CTC LH				101437



Kettle and Drum – Parts Breakdown

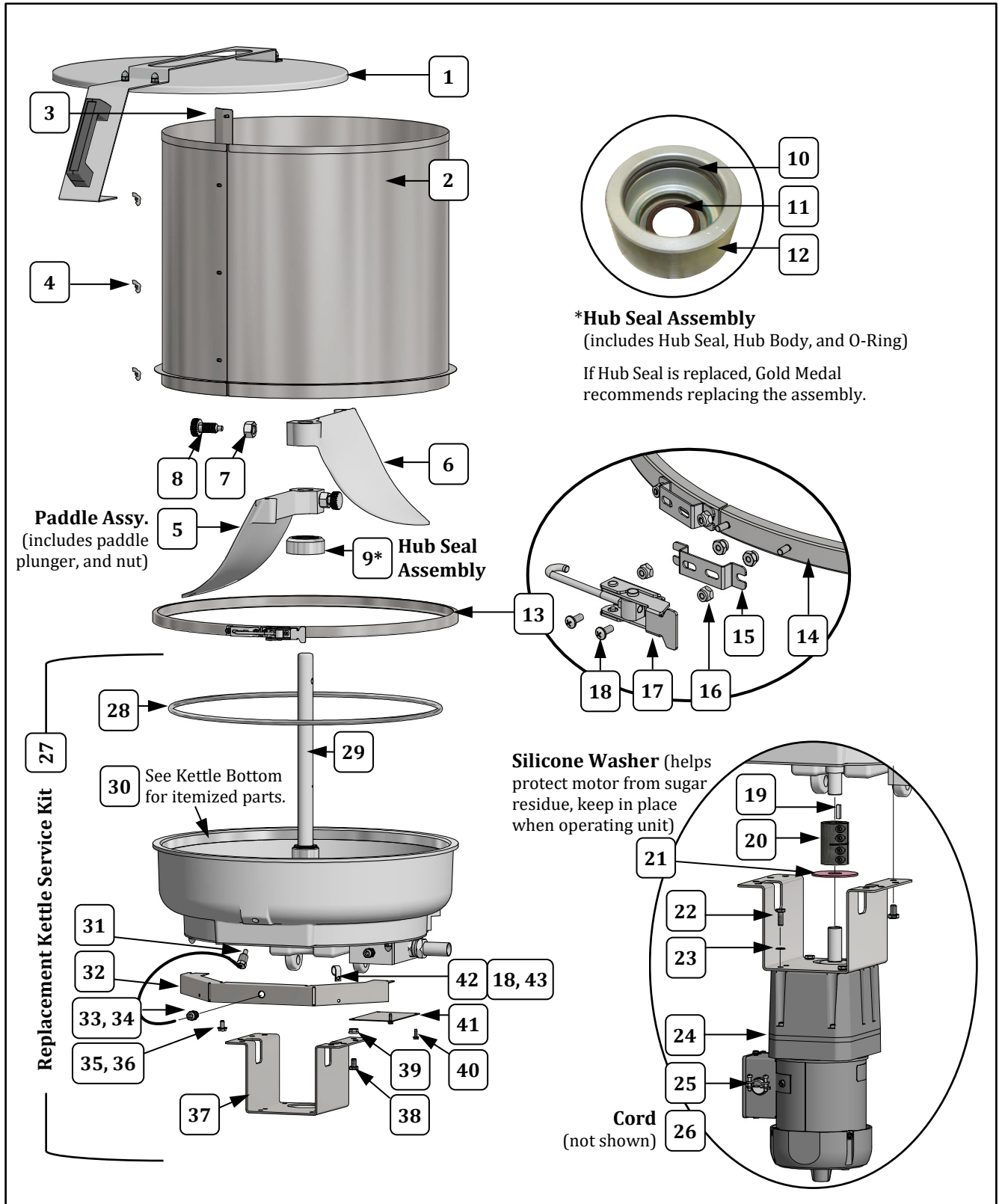



Kettle and Drum – Parts List

Item	Parts Description	Part Number
		All Models
1	MARK 10 LID ASSY	67526
2	MIXING DRUM	48833
3	BLENDING STRIP	46702
4	WING NUT, #8-32	89126
5	MIXER PADDLE ASSY (includes Mix Paddle, Hex Nut and Plunger)	111416
6	MIXER PADDLE MACHINED	111415
7	HEX NUT 5/8-11	111402
8	PLUNGER 5/8-11	111401
9*	HUB SEAL ASSY MARK 10,20 (includes Hub Seal, Hub Body, and O-Ring)	46646
10	O-RING 1 3/4ID X 20D	46641
11	HUB SEAL (If Hub Seal needs replacement, Gold Medal recommends replacing the assembly.)	46640
12	HUB SEAL BODY	46642
13	RETAINING RING ASSY (complete ring with latch)	114660
14	RETAINING RING SUBASSY	114641
15	DRAW LATCH BRACKET	114663
16	8-32 HEX NUT, ESLOK, S.S.	22070
17	ADJUSTABLE DRAW LATCH	114662
18	8-32 X 3/8 PAN HD PH M/S	12389
19	KEY (.187 X .187 X 3/4)	12509
20	DRIVE COUPLING	48826
21	SILICONE WASHER	114642
22	1/4-20 X 3/4 HEX CAP 18-8 (motor fastener)	12515
23	WASHER 1/4 INTERNAL TOOTH (motor fastener)	12383
24	1/4 HP DRIVE MOTOR	48880
25	STRAIN RELIEF T&B 3302	89045
26	FLEXIBLE CORD #18-5	41496

Item	Parts Description	Part Number	
		RH Dump 2410-00-100, 2410-00-102	LH Dump 2410-00-110, 2410-00-112
27	SERVICE KIT MARK10 KETTLE (RH or LH Replacement Kit includes parts listed below.)	114993-00	114993L-00
28	DRUM SEAL	48834	48834
29	DRIVE SHAFT	111406	111406
30	KETTLE ASSEMBLY (see Kettle Bottom section for itemized parts breakdown)	114649-00	11469L-00
31	NPT TYPE K TC	119010	119010
32	SENSOR WIRE SHIELD	114666	114666
33	Ni PLATED STRAIN RELIEF	119026	119026
34	LOCKNUT FOR 119026	119027	119027
35	1/4-20 X 1/2 HX HD SCREW	12382	12382
36	FLAT WASHER 1/4 STAINLESS	87261	87261
37	MOTOR MOUNT	48818	48818
38	5/16-18 X 1/2 HHC GRADE 2	47206	47206
39	5/16-18 SERRATED LOCK NUT	49317	49317
40	8-32 X 1/2 SLOTTED H W H	49379	49379
41	JUNCTION BOX COVER	83262	83262
42	CABLE CLAMP	87219	87219
43	8-32 SERRATED FLANGE NUT	61151	61151



Kettle Bottom – Parts Breakdown

Kettle Bottom parts shown are included in the **Replacement Kettle Service Kit**, see previous section, Kettle and Drum, for parts breakdown of service kit.

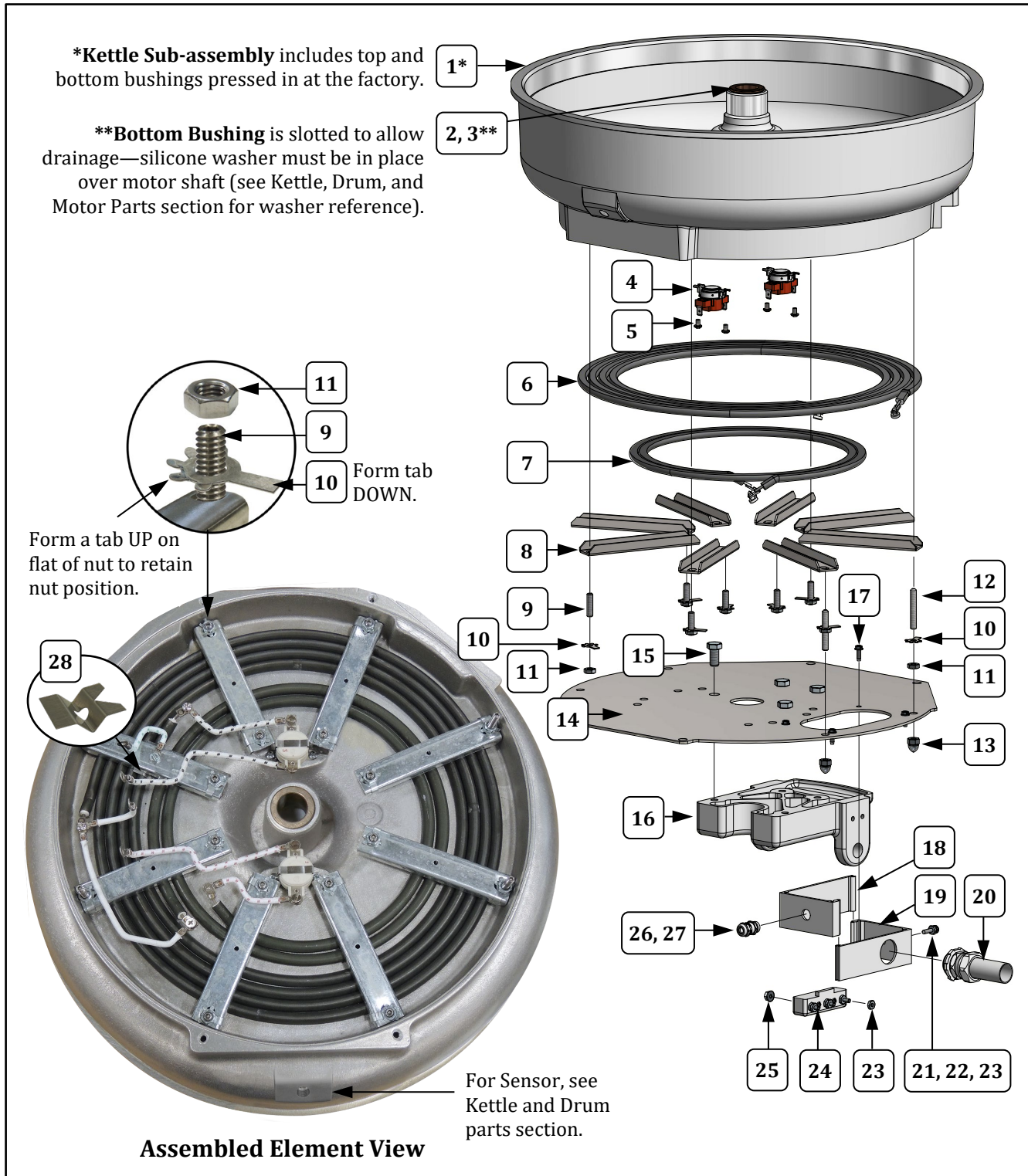



Kettle Bottom – Parts List

Item	Part Description	Part Number	
		2410-00-100, 2410-00-102	2410-00-110, 2410-00-112
	KETTLE ASSEMBLY, RH DUMP (includes parts listed below)	114649-00	
	KETTLE ASSEMBLY, LH DUMP (includes parts listed below)		11469L-00
1	KETTLE SUBASSEMBLY (includes kettle casting and top and bottom bushings pressed in at the factory)	114651	114651
2	FLANGE BUSHING MIX BOWL (top bushing)	46484	46484
3	FLANGE BUSHING W/ GROOVE (bottom bushing)	114476	114476
4	THERMOSTAT KETTLE L-510	82219	82219
5	8-32 X 1/4 PHIL PAN M/S (thermostat screw, 2 required for each thermostat)	87314	87314
6	HEAT ELEMENT 120V,2700W	46491	46491
7	TUBULAR ELEMENT, 1800W	48650	48650
8	ELEMENT CLAMP (8 required)	46492	46492
9	1/4-20 X 1 SET SCREW	59034	59034
10	NUT RETAINER	50190	50190
11	HEX NUT 1/4-20	74133	74133
12	1/4-20 X 1.75 SET SCREW	76444	76444
13	1/4-20 ACORN NUT	49068	49068
14	BOTTOM PLATE	46211	46211
15	HEX BOLT 3/8-16 X 3/4	20051	20051
16	PIVOT CASTING MACHINED	48810	48810
17	8-32 X 1/2 SLOTTED H W H (screws for cover)	49379	49379
18	JUNCTION BOX TERMINAL-SIDE	114643	114643
19	JUNCTION BOX LEAD-SIDE	55313	55313
20	KETTLE LEAD IN ASSY (includes connectors)	46546	46546
21	8-32 X 3/4 PHIL PAN MS SS	39007	39007
22	#8 INT. TOOTH L/W 410SS	12132	12132
23	8-32 HEX M/S NUT	74149	74149
24	TERMINAL BLOCK	41129A	41129A
25	8-32 SERRATED FLANGE NUT	61151	61151
26	Ni PLATED STRAIN RELIEF	119026	119026
27	LOCKNUT FOR 119026	119027	119027
28	ELEMENT SHIM (only used as needed)	68787	68787



Control Box Interior and Exterior

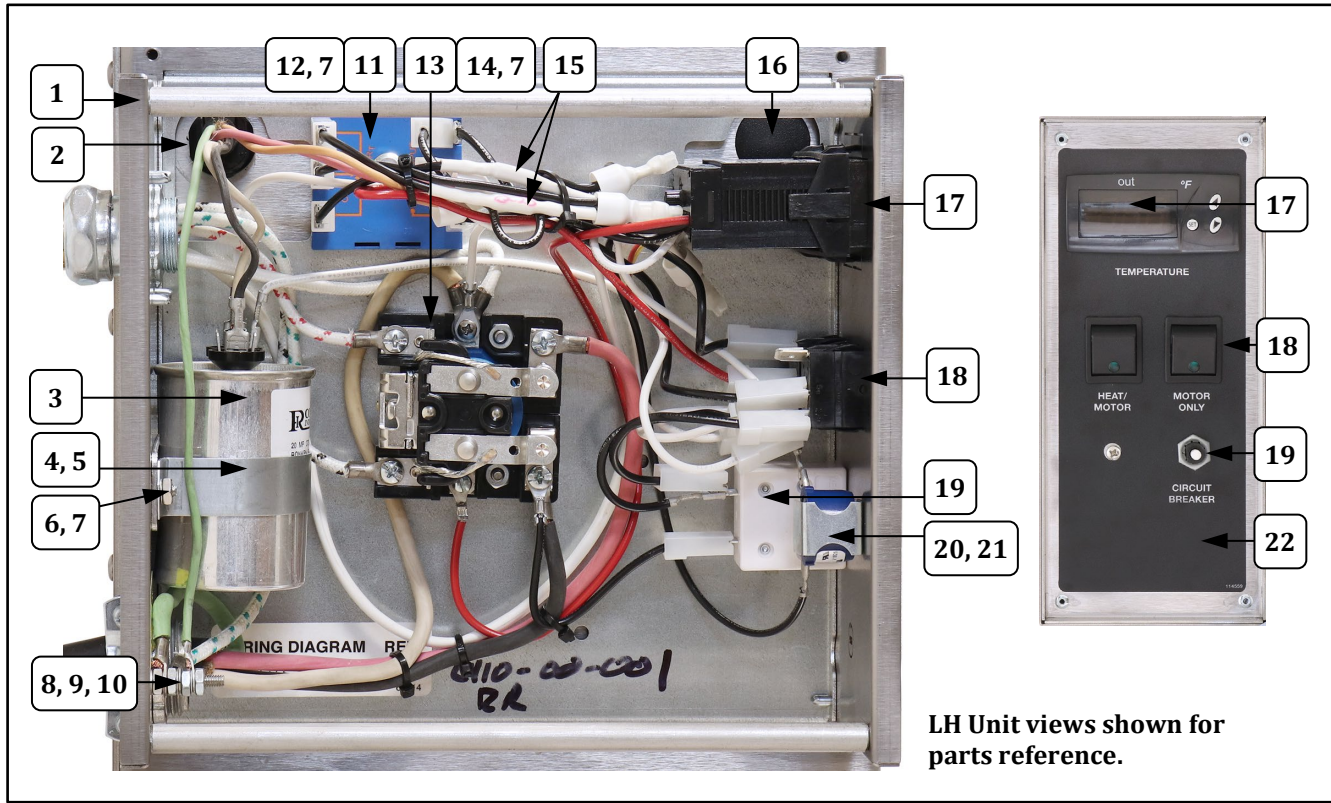

Item	Parts Description	Part Number	
		2410-00-100, 2410-00-102	2410-00-110, 2410-00-112
1	CONTROL BOX (inclds support rods)	101458	101458L
2	STRAIN RELIEF SR-31-2	41735	41735
3	20 MFD CAPACITOR	55558	55558
4	CAPACITOR STRAP	101487	101487
5	CAPACITOR SPACER	101483	101483
6	8-32 X 1/2 PHIL PN M/S SS	42226	42226
7	8-32 SERRATED FLANGE NUT	61151	61151
8	8-32 X 1 PH PAN M/S.S.	12219	12219
9	#8 INT. TOOTH L/W 410SS	12132	12132
10	8-32 HEX M/S NUT	74149	74149
11	TIMER, PERCENTAGE 60 SEC	48688	48688
12	8-32 X 1 1/4 PHIL PAN M/S	47126	47126
13	RELAY, 30A DPST 120V	55219	55219
14	8-32 X 3/4 PHIL PAN MS SS	39007	39007
15	RESISTOR, 500K 1 WATT (2 required)	55009	55009
16	STRN RELIEF PLUG .875 DIA	101500	101500
17	PROGRAMMED CONTROL	101494-000	101494-000
18	SWITCH, ROCKER DPDT LGHT	48616	48616
19	CIRCUIT BREAKER 15 AMP	47364	47364
20	BUZZER SIGNAL	46118	46118
21	6-32 X 3/8 PHIL PAN M/S	39000	39000
22	CONTROL BOX LABEL	114559	114559



Wiring Diagram

Model No. 2410 Series

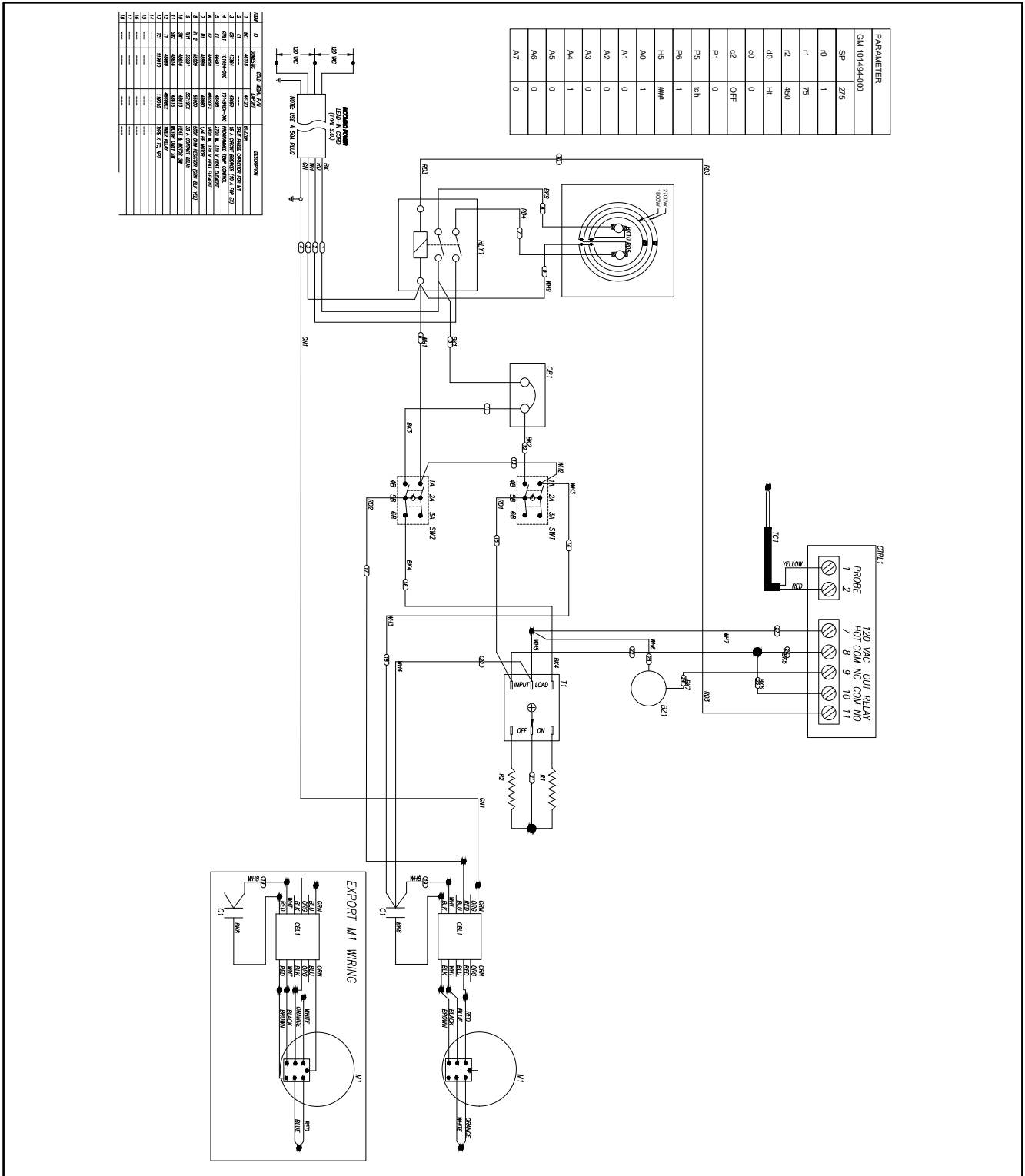



WARRANTY

Gold Medal Products Co. warrants to the original purchaser each item of its manufacture to be free of defects in workmanship and material under normal use and service. Gold Medal Products Co.'s obligation under this warranty is limited solely to repairing or replacing parts, f.o.b. Cincinnati, Ohio, which in its judgment are defective in workmanship or material and which are returned, freight prepaid, to its Cincinnati, Ohio factory or other designated point. Except for "Perishable Parts" on specific machines, the above warranty applies for a period of two (2) years from the date of original sale to the original purchaser of equipment when recommended operating instructions and maintenance procedures have been followed. These are packed with the machine. Parts warranty is two (2) years, labor is six (6) months.

THIS WARRANTY IS IN LIEU OF ALL OTHER WARRANTIES EXPRESSED OR IMPLIED, AND OF ALL OTHER OBLIGATIONS OR LIABILITIES ON OUR PART, INCLUDING THE IMPLIED WARRANTY OF MERCHANTABILITY. THERE ARE NO WARRANTIES WHICH EXTEND BEYOND THE DESCRIPTION ON THE FACE HEREOF. In no event shall Gold Medal Products Co. be liable for special, incidental or consequential damages. No claim under this warranty will be honored if the equipment covered has been misused, neglected, damaged in transit, or has been tampered with or changed in any way. No claim under this warranty shall be honored in the event that components in the unit at the time of the claim were not supplied or approved by Gold Medal Products Co. This warranty is effective only when electrical items have been properly attached to city utility lines only at proper voltages. This warranty is not transferable without the written consent of Gold Medal Products Co.

The term "Original Purchaser" as used in this warranty shall be deemed to mean that person, firm, association, or corporation who was billed by the GOLD MEDAL PRODUCTS CO., or their authorized distributor for the equipment.

THIS WARRANTY HAS NO EFFECT AND IS VOID UNLESS THE ORIGINAL PURCHASER FIRST CALLS GOLD MEDAL PRODUCTS CO. AT 1-800-543-0862 TO DISCUSS WITH OUR SERVICE REPRESENTATIVE THE EQUIPMENT PROBLEM, AND, IF NECESSARY, FOR INSTRUCTIONS CONCERNING THE REPAIR OR REPLACEMENT OF PARTS.

NOTE: This equipment is manufactured and sold for commercial use only.



GOLD MEDAL PRODUCTS CO.

10700 Medallion Drive, Cincinnati, Ohio 45241-4807 USA

gmpopcorn.com

Phone: (800) 543-0862 Fax: (800) 542-1496
(513) 769-7676 (513) 769-8500