



Instruction Manual

Counter B.I.B. Dispenser

Model No. 2499-00-200



GOLD MEDAL® PRODUCTS CO.

10700 Medallion Drive, Cincinnati, Ohio 45241-4807 USA



Table of Contents

SAFETY PRECAUTIONS 3

INSTALLATION INSTRUCTIONS 5

 Inspection of Shipment 5

 Manual 5

 Model Description 5

 Items Included with this Unit 5

 Setup 5

 Electrical Requirements 6

 Before You Plug In Machine 6

 Attaching the Butter Flavored Topping Bag 7

OPERATING INSTRUCTIONS 8

 Controls and Their Functions 8

 Adjusting Dispense Settings 9

 Prime Unit for Use 10

 Operating the Dispenser 10

 Auto-Dispense Mode: 10

 Manual Dispense Mode: 10

Care and Cleaning 11

 Daily Cleaning Instructions 11

 Sanitizing the Tubing and Pump 11

Troubleshooting 13

MAINTENANCE INSTRUCTIONS 15

ORDERING SPARE PARTS 16

 Cabinet Front View – Parts Breakdown 17



 Cabinet Rear View – Parts Breakdown 18



 Tower View – Parts Breakdown 20



Wiring Diagram 21



WARRANTY 22



SAFETY PRECAUTIONS

	 DANGER
	<p>Machine must be properly grounded to prevent electrical shock to personnel. Failure to do so could result in serious injury, or death. DO NOT immerse any part of this equipment in water. DO NOT use excessive water when cleaning. Keep cord and plug off the ground and away from moisture. Always unplug the equipment before cleaning or servicing. Make sure all machine switches are in the OFF position before plugging the equipment into the receptacle.</p> <p style="text-align: right; font-size: small;">008_051514</p>

	 DANGER
	<p>Improper installation, adjustment, alteration, service, or maintenance can cause property damage, injury, or death. Any alterations to this equipment will void the warranty and may cause a dangerous condition. This appliance is not intended to be operated by means of an external timer or separate remote-control system. NEVER make alterations to this equipment. Read the Installation, Operating, and Maintenance Instructions thoroughly before installing, servicing, or operating this equipment.</p> <p style="text-align: right; font-size: small;">014_020416</p>



	 WARNING
	<p>To avoid burns, DO NOT touch heated surfaces. DO NOT place or leave objects in contact with heated surfaces.</p> <p style="text-align: right; font-size: small;">009_092414</p>



	 WARNING
	<p>ALWAYS wear safety glasses when servicing this equipment.</p> <p style="text-align: right; font-size: small;">010_010914</p>

	 WARNING
	<p>No user serviceable parts inside. Refer servicing to qualified service personnel.</p> <p style="text-align: right; font-size: small;">011_051514</p>

	 WARNING
	<p>Read and understand operator's manual and all other safety instructions before using this equipment. To order copies of the operator's manual go to gmpopcorn.com or write to Gold Medal Products Co., 10700 Medallion Drive, Cincinnati, OH 45241 USA 1-(800)-543-0862</p> <p style="text-align: right; font-size: small;">022_060215</p>



	 WARNING
	DO NOT allow direct contact of this equipment by the public when used in food service locations. Only personnel trained and experienced in the equipment operation may operate this equipment. Carefully read all instructions before operation. <small>012_010914</small>

	 WARNING
	This machine is NOT to be operated by minors. <small>007_010914</small>

Note: Improvements are always being made to Gold Medal’s equipment. This information may not be the latest available for your purposes. It is critical that you call Gold Medal’s Technical Service Department at 1-800-543-0862 for any questions about your machine operations, replacement parts, or any service questions. (Gold Medal Products Co. does not assume any liability for injury due to careless handling and/or reckless operation of this equipment.) General images may be used in manual for reference only.



INSTALLATION INSTRUCTIONS

Inspection of Shipment

After unpacking, check thoroughly for any damage which may have occurred in transit. Claims should be filed immediately with the transportation company. The warranty does not cover damage that occurs in transit, or damage caused by abuse, or consequential damage due to the operation of this machine, since it is beyond our control (reference warranty in back of manual).

Manual

Read and understand the operator's manual and all other safety instructions before using this equipment. To order copies of the operator's manual go to gmpopcorn.com or write to Gold Medal Products Co., 10700 Medallion Drive, Cincinnati, OH 45241 USA 1-(800)-543-0862.

Model Description

2499-00-200 – Countertop pedestal style topping dispenser with an LED lighted sign, unit holds one 35 lb. bag of butter flavored topping.

Items Included with this Unit

- Small Screwdriver (PN [55554](#)), used for making pump adjustments
- Manual and Warranty Registration Card

Setup

1. Remove all packaging and tape.
2. Place unit on a sturdy, level surface.
3. Unit is preset at factory to dispense a measured amount of topping.



To adjust the dispense amount or speed, see Adjusting Dispense Settings in the Operating Instructions.

4. After setup, the unit should be cleaned prior to use (see Care and Cleaning section of this manual).

Electrical Requirements

The following power supply must be provided (reference unit Data Plate for Wattage requirement):

120 V~, 60 Hz

	 DANGER
	<p>Machine must be properly grounded to prevent electrical shock to personnel. Failure to do so could result in serious injury, or death. DO NOT immerse any part of this equipment in water. DO NOT use excessive water when cleaning. Keep cord and plug off the ground and away from moisture. Always unplug the equipment before cleaning or servicing. Make sure all machine switches are in the OFF position before plugging the equipment into the receptacle.</p> <p style="text-align: right; font-size: small;">008_051514</p>

A certified electrician must furnish sufficient power for proper machine operation and install any supplied receptacle (reference unit Data Plate for model specific Volts AC, Hertz, and Wattage requirements). We recommend this equipment be on a dedicated and protected circuit. Failure to wire properly will void the warranty and may result in damage to the machine. It is Gold Medal Products Co.'s recommendation that this machine be plugged directly into a wall outlet. The use of extension cords is not recommended due to safety concerns, and may cause sacrificed and/or reduced performance. Make sure cord is located to prevent a trip hazard or unit upset.

Before You Plug In Machine

1. Make sure the power switch is OFF before plugging unit into receptacle.
2. Make sure wall outlet can accept the grounded plug on the power supply cord.
3. The wall outlet must have the proper polarity. If in doubt, have a competent electrician inspect the outlet and correct if necessary.
4. **DO NOT** use a grounded to un-grounded receptacle adapter (where applicable).
5. Install unit in a level position.

	 CAUTION
	<p>If the supply cord is damaged, it must be replaced by Gold Medal Products Co., its service agent or similarly qualified persons in order to avoid a hazard.</p> <p style="text-align: right; font-size: small;">039_080614</p>



Attaching the Butter Flavored Topping Bag

Use a maximum of 35 pound bag of topping for this unit.

IMPORTANT: This product is not intended for use with volatile food products (i.e. real butter).

1. Remove the drip pan/insert and top cover from the holding pan base.
2. Remove the cap from the topping bag nozzle.
3. Attach the Universal Bag Connector (located in the holding pan) to the topping bag nozzle (see steps below).
4. Place the topping bag in the unit. Be sure the connection end is put in first and is located on the bottom side of the bag.
5. Replace the top cover, drip pan, and insert.

Steps to Attach the Universal Bag Connector

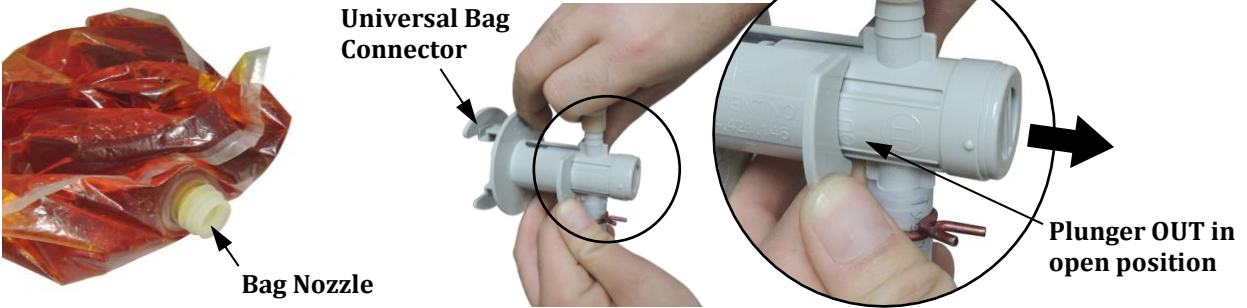

Step 1: Pull the Universal Bag Connector's plunger out until it clicks into the open position.



Step 2: Grasp the Bag Nozzle and slide the Bag Connector on from the side.

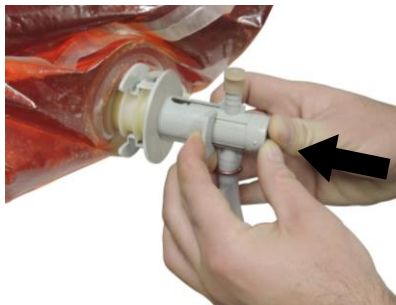

Step 3: With the hose connector in place, press plunger forward to lock.



Step 4: Connector shown with plunger fully forward in lock position.



OPERATING INSTRUCTIONS

Controls and Their Functions

HEAT SWITCH (Power Switch): Three position rocker switch.

HEAT ONLY (up position)—activates the LED lights, unit heating (to maintain topping temperature), and photo-eye sensor—**pump is de-activated in heat only setting.**

CENTER position—power OFF

PUMP & HEAT (down position)—**activates the pump**, LED lights, unit heating (to maintain topping temperature), and photo-eye sensor.

PUSH BUTTON PUMP SWITCH (Manual Dispense): Press the push button to manually dispense topping continuously, release button to stop dispensing.

Note: When a push button is activated, the sensor is deactivated. When popcorn leaves the photo-eye detection area, the sensor becomes active again.

TIMED SWITCH

Two modes are selectable (Timed and Not Timed). In either mode, sensor must detect popcorn for 0.5 sec. before pump is automatically activated.

Note: To switch between Timed and Not Timed Modes, power the unit OFF for the mode change to take effect.

Timed Mode – The pump turns on for a pre-determined length of time when photo-eye detects a cup of popcorn. To adjust time, see Adjusting Dispense Settings section.

Note: The pump stops if popcorn is removed prematurely (if popcorn is brought back within one second, the timer will resume and finish the timing period).

Not Timed Mode – The pump **runs continuously** as long as the photo-eye detects a cup of popcorn.

PHOTO-EYE SENSOR (Auto-Dispense): Photo-eye must detect popcorn within about 5 inches (13 cm) of the sensor for 0.5 sec. before pump is automatically activated (see image below for sensor indicator lights).

Note: A slight delay is required after the popcorn is removed for the sensor to reactivate.

When wiping off the unit, shiny objects such as a watch can activate the photo-eye at distances greater than 5 inches.

PUMP SPEED ADJUSTMENT: Use adjustment to set how **fast** topping is dispensed (see Adjusting Dispense Settings on next page).

DISPENSE TIME ADJUSTMENT (Auto-Dispense): Use adjustment to set how **long** topping is dispensed (settable from 3.0 to 9.4 sec.) (see Adjusting Dispense Settings on next page).

1 AMP FUSE: Protects pump from overload condition.

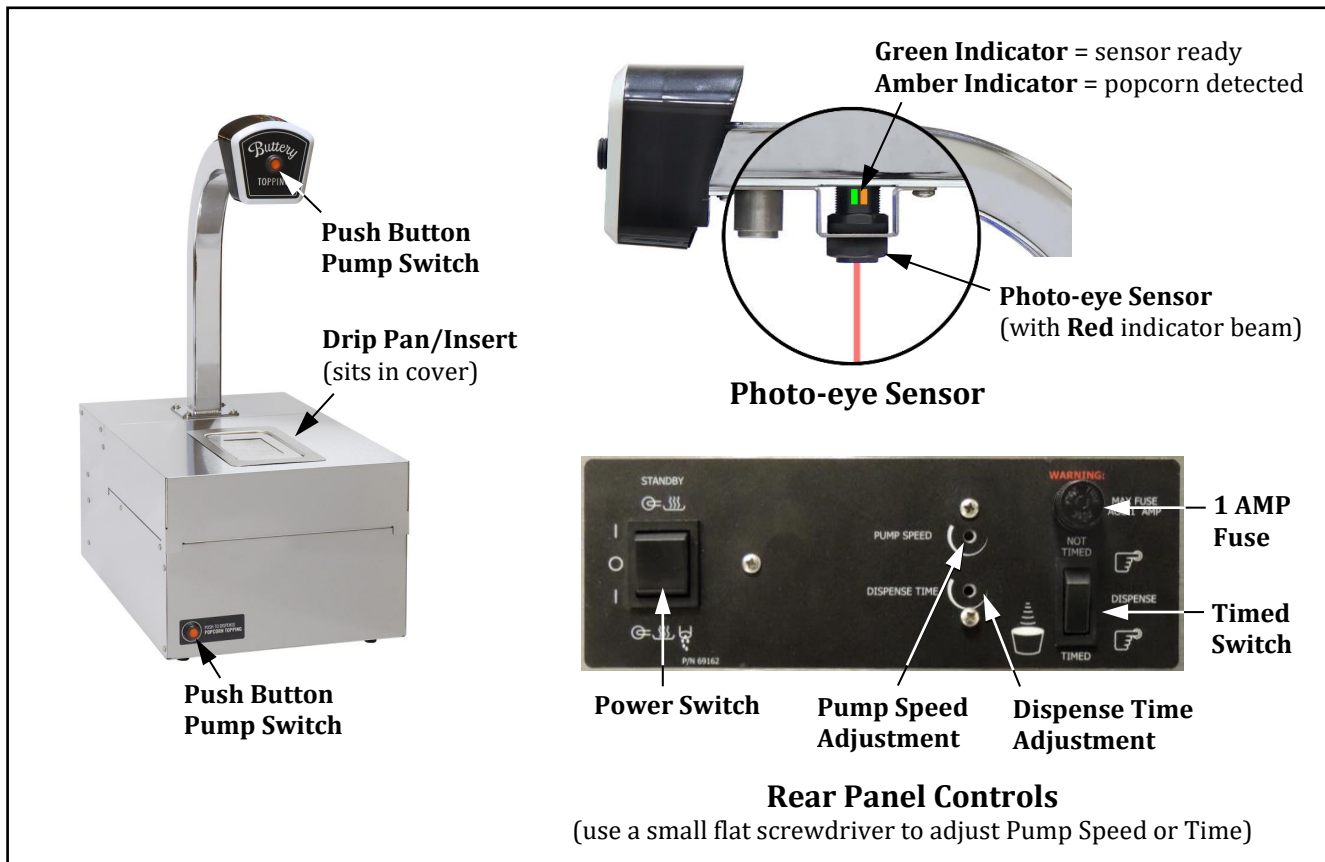

Adjusting Dispense Settings

To switch between Timed and Not Timed Modes, power the unit OFF for the mode change to take effect.

Auto Dispense:

Timed Mode - Adjust the pump speed, pump time (from 3.0 to 9.4 sec.), or both.

Not Timed Mode - Adjust the pump speed only.

Manual Dispense: Adjust the pump speed only.

1. Use a small flat screwdriver to turn adjustment (located on rear control panel).
2. Turn **clockwise** to increase setting.
Turn **counter-clockwise** to decrease setting (full counter-clockwise is the lowest setting).
3. Test the setting.



Prime Unit for Use

Prime the dispenser lines after adding topping.

1. Set Heat Switch to HEAT & PUMP.
2. To properly prime the unit—hold a cup under nozzle and press a dispense button until topping comes out in a **steady, bubble free liquid stream**.

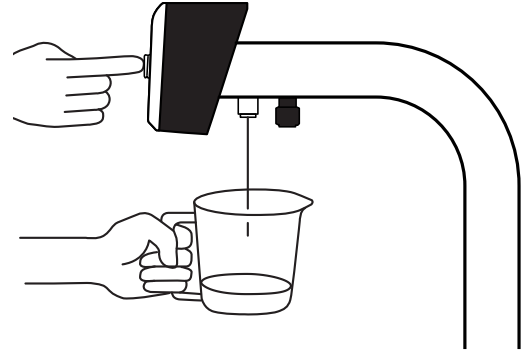

Operating the Dispenser

Prime the dispenser lines after adding topping, then unit is ready for dispensing. (For any sensor issues and indicator light descriptions reference the Troubleshooting section.)

1. Set Heat Switch to HEAT ONLY for 30 minutes to allow topping to preheat—pump is deactivated in this position.
2. After topping is warmed, set Power Switch to HEAT & PUMP.
3. Set Timed Switch to TIMED or NOT TIMED dispense mode.
Note: To switch between modes, power the unit OFF for the mode change to take effect.
4. Use Auto or Manual Dispense Mode shown below.

Auto-Dispense Mode:

1. Place popcorn about 5" (13 cm) under sensor.
2. Sensor will auto-detect popcorn and dispense topping (sensor must see product for 0.5 sec. to begin dispensing).

Note: A slight delay is required after popcorn is removed for the sensor to reactivate.

To adjust the dispense settings, reference Adjusting Dispense Settings section.

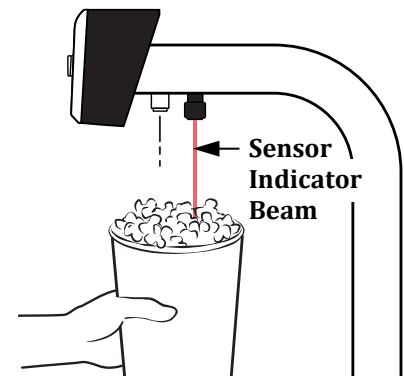

Manual Dispense Mode:

1. Place popcorn about 5" (13 cm) under nozzle.
2. Press and hold a dispense button for desired amount of topping.

Note: If button is released before desired amount is dispensed, remove popcorn and wait 2 sec., then repeat step 2.



To adjust the dispense speed, reference Adjusting Dispense Settings section.

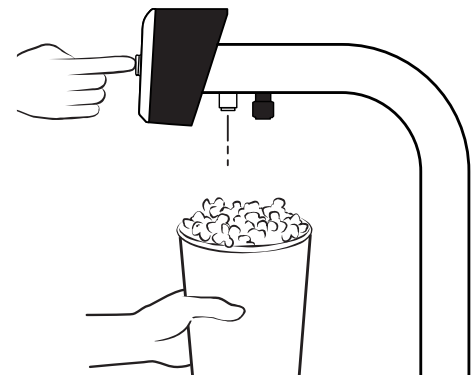

3. Release button to stop dispensing.





Care and Cleaning

	 DANGER
	<p>Machine must be properly grounded to prevent electrical shock to personnel. DO NOT immerse in water. DO NOT clean appliance with a water jet. Always unplug the equipment before cleaning or servicing.</p> <p style="text-align: right; font-size: small;">025_111616</p>

	 WARNING
	<p>To avoid burns, DO NOT touch heated surfaces. DO NOT place or leave objects in contact with heated surfaces.</p> <p style="text-align: right; font-size: small;">009_092414</p>

Good sanitation practice demands that all food preparation equipment be cleaned regularly (only use non-toxic, food grade cleaners).

For surfaces needing further cleaning or degreasing, Watchdog Stainless Cleaner (Item No. 2088) or Watchdog Concession Equipment Degreaser (Item No. 2580) is available for use accordingly. For any cleaning products used, follow the manufacturer's instructions on the product. **DO NOT use oven cleaners or abrasive materials** as they will damage parts of machine.

Daily Cleaning Instructions

1. Turn machine OFF, unplug the unit and allow it to cool before attempting to clean.
2. Lift the drip pan and insert from cover and wash them at the sink with mild soap and warm water, then rinse and dry.
3. Wipe unit surfaces clean with a SLIGHTLY damp cloth (cloth may be SLIGHTLY dampened with soap and water, then wipe again to remove any cleaner).
4. Nozzle is designed to be drip free. Butter flavored topping can accumulate and cause the nozzle to clog.

If nozzle becomes clogged, use a paperclip or small diameter rod to clear the opening (3/32" hole).

5. Reassemble the unit.

Sanitizing the Tubing and Pump

Items Needed: **(2) Empty Pails, (1) Cleaning Bracket** (Item No. [12594](#))
Gold Medal Chlor-Tech Sanitizer (Item No. [1109](#))
Medium Size Container (for priming unit)

1. Make sure the unit has cooled completely before attempting to clean.
2. Fill a clean bucket half-full with hot water and Gold Medal Chlor-Tech Sanitizer (reference instructions on sanitizer container for appropriate amount).



- Nozzle is designed to be drip free. Butter flavored topping can accumulate and cause the nozzle to clog.
If nozzle becomes clogged, use a paperclip or small diameter rod to clear the opening (3/32" hole).
- Disconnect Universal Bag Connector from topping bag and connect it to cleaning bracket as shown below. **Make sure the plunger is engaged on pin.**

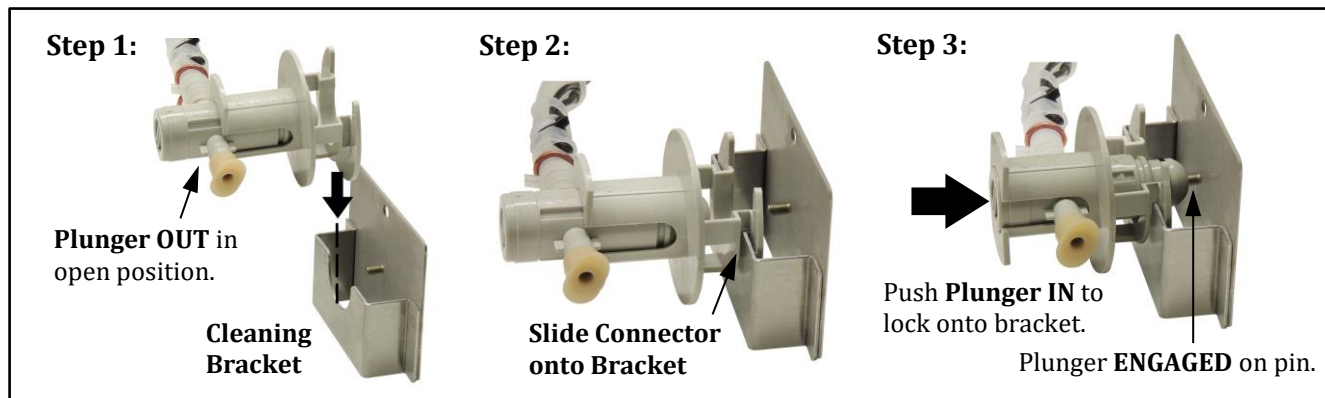

- Place hose with cleaning bracket into pail of sanitizing solution.
- Place an empty pail under dispensing nozzle to receive cleaning solution pumped through unit.
- Use a dispense button to dispense solution until tubes are clean and free of topping.
- When pumping is complete, discard dirty solution, clean the pail, and refill with clean hot water.
- Remove hose with bracket from solution pail and place it in the hot water.
- Place an empty pail under nozzle.
- Use a dispense button to dispense hot water until tubes are cleared of sanitizer.
- When cleansing is complete, remove pail from dispenser.
- Remove hose with bracket from hot water, disconnect bracket, and wipe hose and bag connector dry.
- Reconnect dispenser to bag of topping.
- Purge and prime the lines—hold a measuring cup (or medium sized container) under nozzle and press a dispense button until all water has been purged and tubes are primed with topping. After cleaning, always discard the topping dispensed in priming.
- Sanitize cleaning items for next use.



Troubleshooting

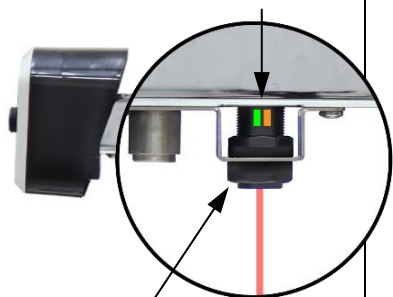

Issue	Possible Cause	Solution
No Power to the Unit	A. No power to the unit	A. Make sure unit is plugged in and Power Switch is ON (green switch light should be ON). If switch light does not turn on, have a qualified electrician check the power supplied to unit.
Unit Does Not Dispense or Delayed Dispense	A. Pump Fuse B. Topping empty C. Clogged nozzle – Topping can accumulate and cause the nozzle to clog. D. Pump needs to be primed.	A. Check fuse. If replaced and trips again, check with a qualified service person for inspection/repair. B. Make sure there is topping in the bag. Reference the Topping Installation section in the Installation Instructions. C. If nozzle becomes clogged, use a paperclip or small diameter rod to clear the opening (3/32" hole). Reference the Cleaning and Care section. D. See Prime Unit for Use in the Operating Instructions.
Unit Does Not Dispense or Delayed Dispense Sensor – Indicator Lights	A. Sensor wait time in Auto-Dispense Mode B. Dispense delay in Manual Dispense Mode C. Sensor faulty (sensor indicators) Green Light = sensor ready Amber Light = object detected  Photo-eye Sensor with Red indicator beam (red beam shown enhanced for reference purposes)	A. Sensor must see popcorn within 5" of sensor for 0.5 sec. to begin dispensing. A slight delay is required after popcorn is removed for the sensor to reactivate (reference, Operating the Dispenser section). B. Unit dispenses continuously when dispense button is held. If button is released, remove popcorn and wait 2 sec. to reactivate the pump. C. Check side of sensor for indicator lights. If an indicator light does not come on as specified, photo-eye may be faulty. Check with a qualified service person for inspection/repair. Green Indicator = sensor ready, powered Automatic Mode: Popcorn must be approx. 5" from photo-eye for sensor to detect it. Amber Indicator = object detected Automatic Mode: Amber light turns on when sensor detects popcorn for 0.5 sec. (remove popcorn from sensor area for 2 sec. for sensor to reactivate). Manual Mode: When dispense button is pressed, control ignores photo-eye sensor and manually dispenses. Red Indicator Beam = photo-eye detection





Issue	Possible Cause	Solution
Wrong Dispense Amount	A. Pump needs to be primed B. Pump settings need adjustment.	A. See Prime Unit for Use in the Operating Instructions. B. Pump Speed Adjustment: Use adjustment on rear control panel to set how fast topping is dispensed (see Adjusting Dispense Settings section in the Operating Instructions). Dispense Time Adjustment: Use adjustment on rear control panel to set how long topping is dispensed (settable from 0.2 to 2.0 sec.) (see Adjusting Dispense Settings section in the Operating Instructions).





MAINTENANCE INSTRUCTIONS

	 DANGER
	<p>Machine must be properly grounded to prevent electrical shock to personnel. Failure to do so could result in serious injury, or death. DO NOT immerse any part of this equipment in water. DO NOT use excessive water when cleaning. Keep cord and plug off the ground and away from moisture. Always unplug the equipment before cleaning or servicing. Make sure all machine switches are in the OFF position before plugging the equipment into the receptacle.</p> <p style="text-align: right; font-size: small;">008_051514</p>

	 DANGER
	<p>Improper installation, adjustment, alteration, service, or maintenance can cause property damage, injury, or death. Any alterations to this equipment will void the warranty and may cause a dangerous condition. This appliance is not intended to be operated by means of an external timer or separate remote-control system. NEVER make alterations to this equipment. Read the Installation, Operating, and Maintenance Instructions thoroughly before installing, servicing, or operating this equipment.</p> <p style="text-align: right; font-size: small;">014_020416</p>

	 WARNING
	<p>No user serviceable parts inside. Refer servicing to qualified service personnel.</p> <p style="text-align: right; font-size: small;">011_051514</p>

	 CAUTION
	<p>THE FOLLOWING SECTIONS OF THIS MANUAL ARE INTENDED ONLY FOR QUALIFIED SERVICE PERSONNEL WHO ARE FAMILIAR WITH ELECTRICAL EQUIPMENT. THESE ARE NOT INTENDED FOR THE OPERATOR.</p> <p style="text-align: right; font-size: small;">027_010914</p>



ORDERING SPARE PARTS

1. Identify the needed part by checking it against the photos, illustrations, and/or parts list. (General images may be used in manual for reference only.)
2. Use only approved replacement parts when servicing this unit.
3. When ordering, please include part number, part name, and quantity needed.
4. Please include your model number, serial number, and date of manufacture (located on the machine nameplate/data plate) with your order.
5. Address all parts orders to Parts Department, Gold Medal Products Co., 10700 Medallion Drive, Cincinnati, Ohio 45241-4807

or place orders by phone or online:

Phone: (800) 543-0862
(513) 769-7676

Fax: (800) 542-1496
(513) 769-8500

E-mail: info@gmpopcorn.com
Web Page: gmpopcorn.com



Cabinet Front View – Parts Breakdown

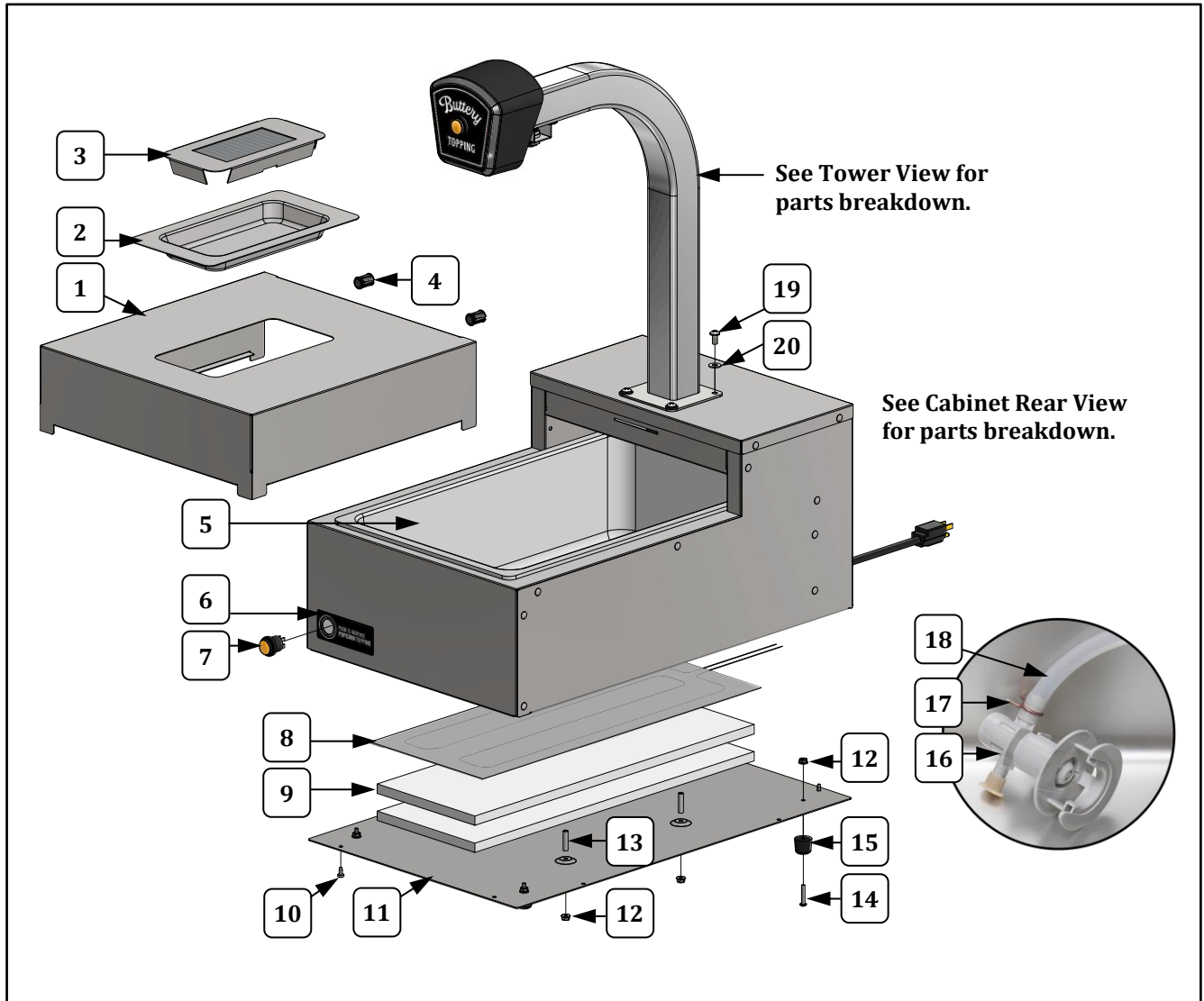

Item	Part Description	Part Number 2499-00-200
1	LID (storage tank cover)	114576
2	DRIP PAN	69148
3	DRIP PAN INSERT	69201
4	MAGNETIC CATCH	16141
5	PAN WELDMENT	114573
6	DISPENSE LABEL	114652
7	PUSHBUTTON SWITCH AMBER	55658
8	FOIL ELEMENT 300W 120V	39949
9	INSULATION WRAP (2 req'd)	38294
10	SCREW #8-32X3/8 PAN HD PH	74141
11	BOTTOM COVER	114574

Item	Part Description	Part Number 2499-00-200
12	8-32 SERRATED FLANGE NUT	61151
13	SPACER .180"ID X 1.030"LG (for studs on pan weldment, 4 req'd)	88594
14	8-32 X 1 PH PAN M/S S.S.	12219
15	RUBBER FEET 3/4IN HIGH (4 req'd)	47155
16	UNIVERSAL BAG CONNECTOR	79100G
17	SINGLE WIRE HOSE CLAMP	75110
18	PLASTIC FOOD TUBING (sold by the foot)	91375
19	1/4-20 X 1/2 P/H PHIL	12471
20	FLAT WASHER 1/4 STAINLESS	87261



Cabinet Rear View – Parts Breakdown

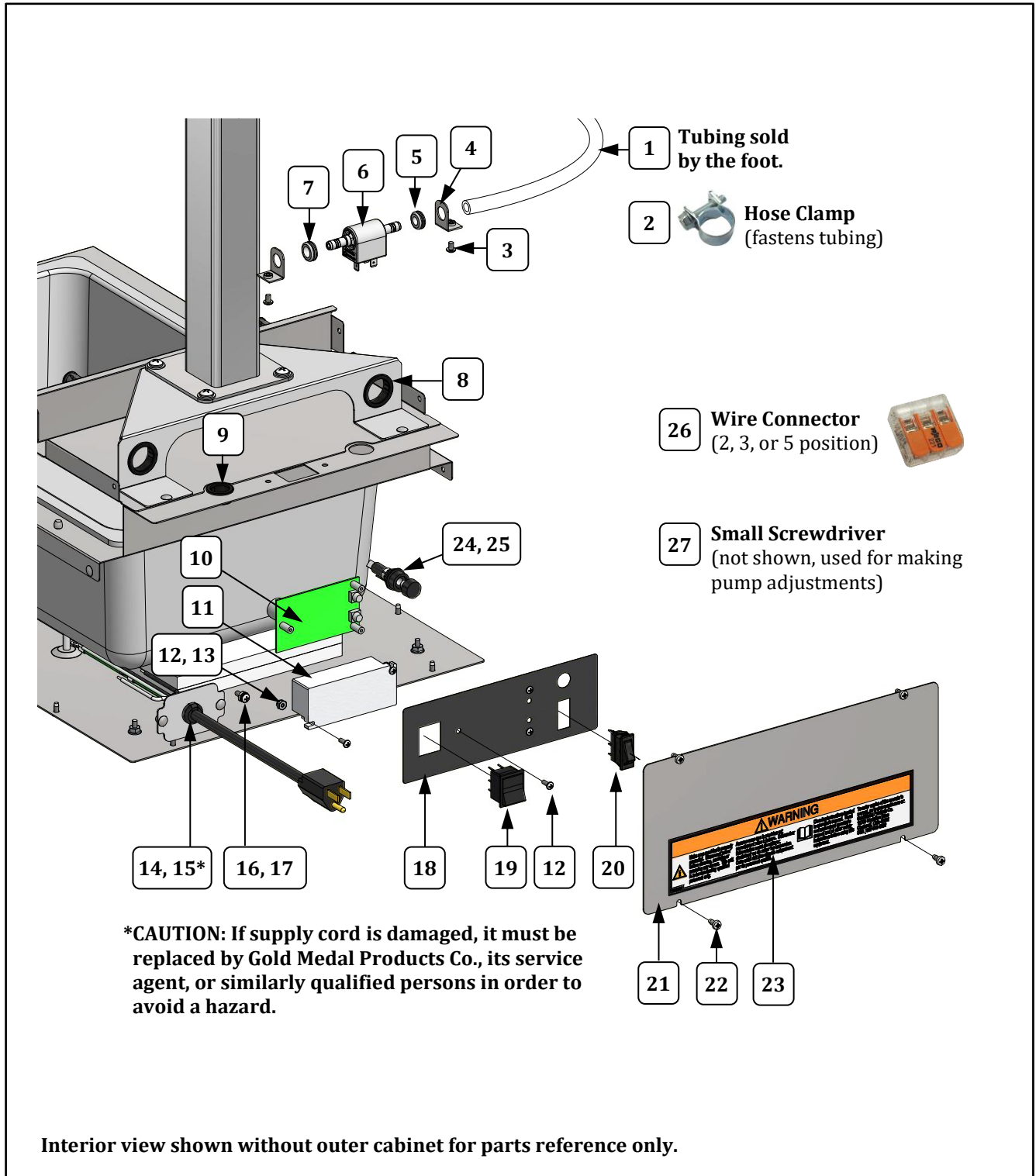



Cabinet Rear View – Parts List

Item	Part Description	Part Number
		2499-00-200
1	PLASTIC FOOD TUBING (sold by the foot)	91375
2	HOSE CLAMP 7/16in - 1/2in	67843
3	8-32 X 1/4 PHIL PAN M/S	87314
4	PUMP BRACKET 2499 (2 required)	69157
5	GROMMET	69159
6	PUMP	79888
7	GROMMET	69158
8	BUSHING, SNAP 1.125 IN	82221
9	BUSHING, SNAP .875 IN	45396
10	BUTTER DISPENSE PCB	69175
11	POWER SUPPLY, 12VDC	55231
12	6-32 X 3/8 PHIL PAN M/S	39000
13	6-32 GRIP NUT ZINC PLATED	47517
14	STRAIN RELIEF SR-6P3-4	76026
15*	POWER SUPPLY CORD 15 AMP	22038
16	8-32 X 1/2 PH PAN W/SEMS (fastens ground)	47124
17	HEX NUT #8-32 STAINLESS (fastens ground)	89129
18	DECAL CONTROL FOR 2499A	69162
19	3 POSITION ROCKER SWITCH	39410
20	SWITCH, ROCKER SPDT	55050
21	REAR COVER	114575
22	SCREW #8-32X3/8 PAN HD PH (fastens cover)	74141
23	UNIV WARN LBL HORZ	115180
24	FUSEHOLDER	74636
25	FUSE, 1 AMP	79341
26	2 POSITION WIRE CONNECTOR	55621
	3 POSITION WIRE CONNECTOR	55244
	5 POSITION WIRE CONNECTOR	55245
27	SMALL SCREWDRIVER (not shown)	55554

Tower View – Parts Breakdown

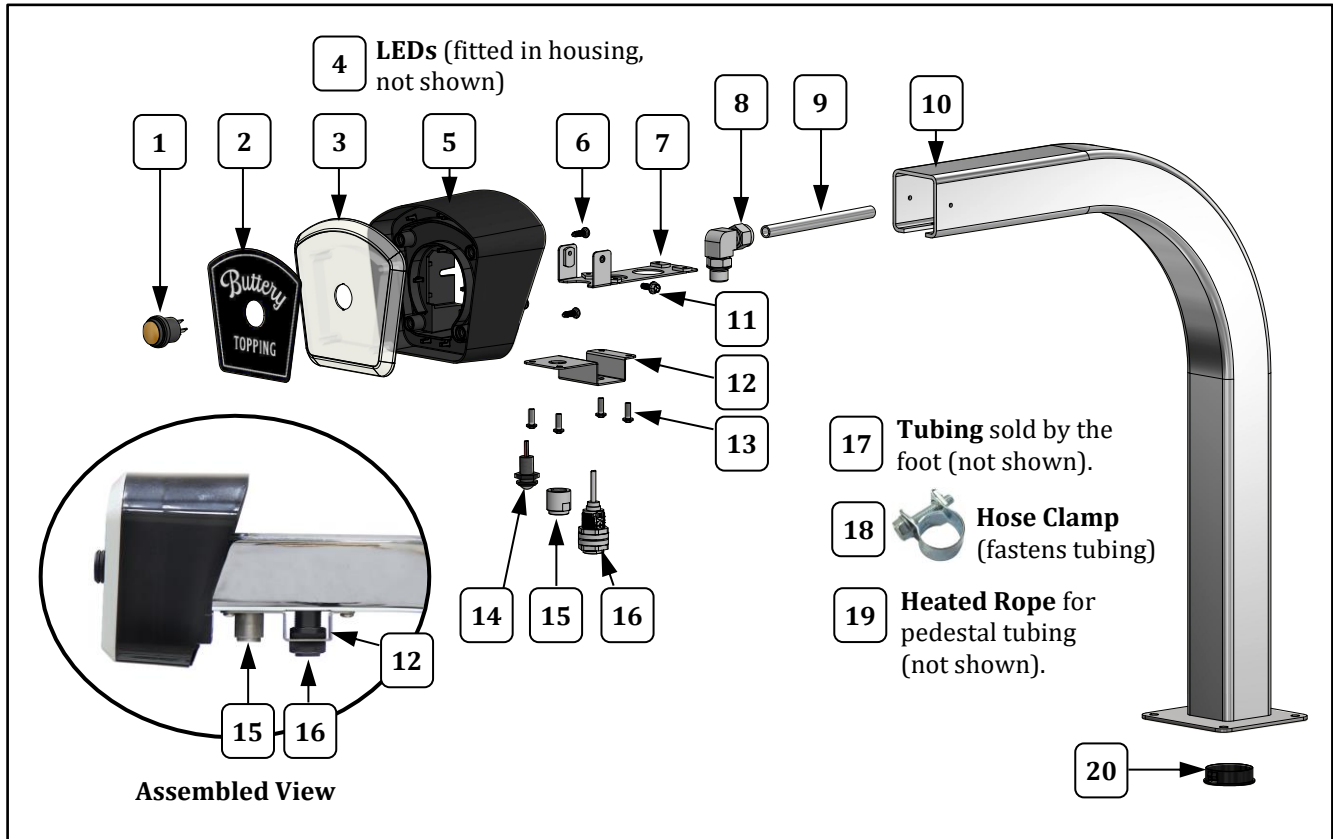

Item	Part Description	Part Number
		2499-00-200
1	PUSHBUTTON SWITCH AMBER	55658
2	DISPENSER DECAL LABEL	114619
3	DISPENSE HEAD COVER	114630
4	12V LED SIDE EMITTING WHT	114618
5	DISPENSE HEAD BODY	114629
6	8-18 X 1/2 SS PH TYPE BT (fastens head cover)	114616
7	MOUNT BRACKET WELDMENT	114405
8	MALE ELBOW TUBE FITTING	114583
9	3/8IN SS TUBE 5IN LONG	114727
10	DISPENSER BODY WELDMENT	114104
11	8-32X1/2 FLANGE HEX SCREW (fastens bracket to body weldment)	114770
12	MOUNT PLATE - PHOTO EYE	114408
13	8-32 X 1/2 PHIL PN M/S SS	42226
14	12V LED SPOT LIGHT	114617
15	NO DRIP SPOUT	114450
16	PHOTOELECTRIC SENSOR	69174
17	PLASTIC FOOD TUBING (sold by the foot)	91375
18	HOSE CLAMP 7/16in - 1/2in	67843
19	HEATED ROPE WIRE ASSY	39471
20	BUSHING, SNAP 1.500 IN	74621



Wiring Diagram

Model No. 2499-00-200

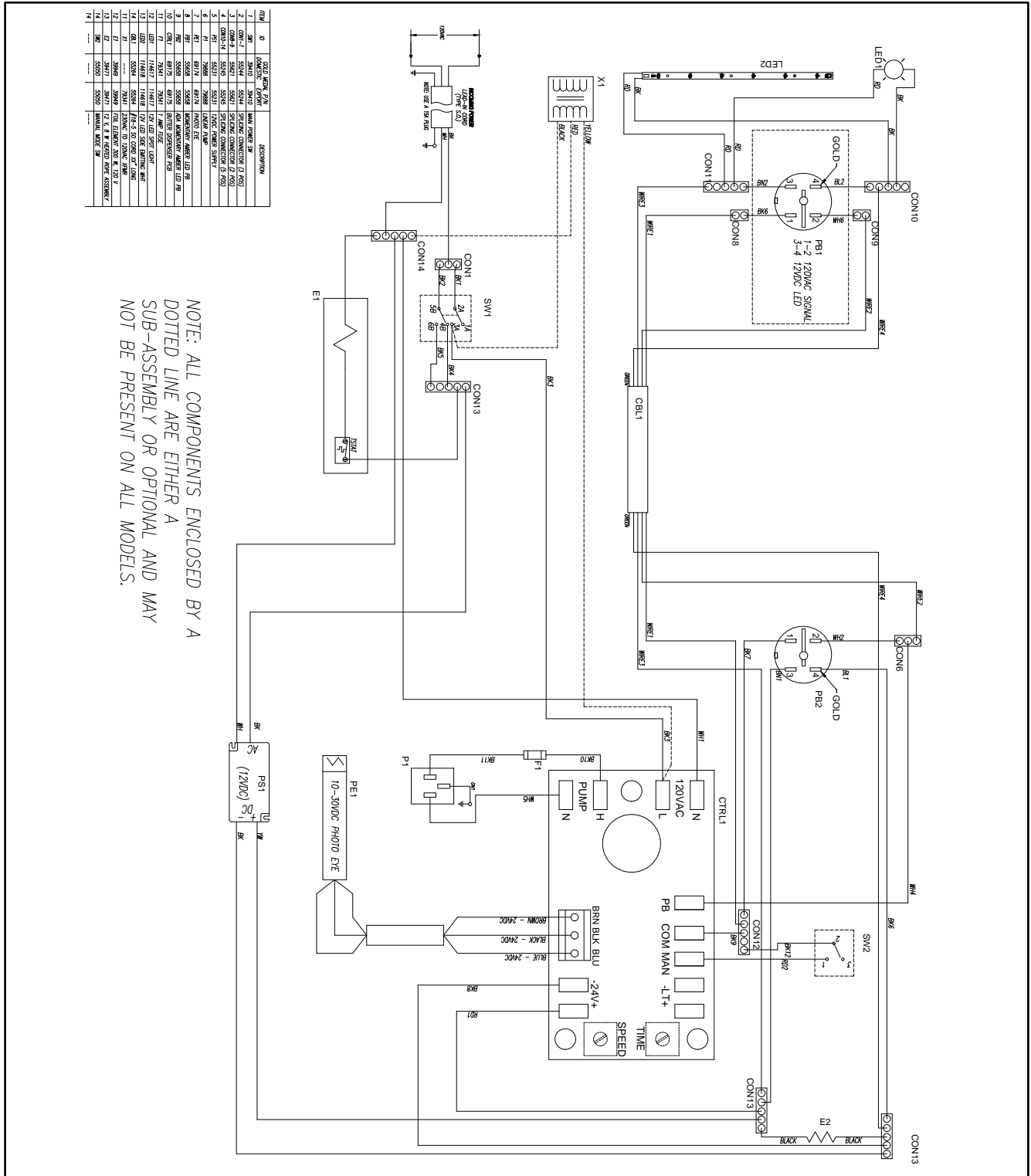



WARRANTY

Gold Medal Products Co. warrants to the original purchaser each item of its manufacture to be free of defects in workmanship and material under normal use and service. Gold Medal Products Co.'s obligation under this warranty is limited solely to repairing or replacing parts, f.o.b. Cincinnati, Ohio, which in its judgment are defective in workmanship or material and which are returned, freight prepaid, to its Cincinnati, Ohio factory or other designated point. Except for "Perishable Parts" on specific machines, the above warranty applies for a period of two (2) years from the date of original sale to the original purchaser of equipment when recommended operating instructions and maintenance procedures have been followed. These are packed with the machine. Parts warranty is two (2) years, labor is six (6) months.

THIS WARRANTY IS IN LIEU OF ALL OTHER WARRANTIES EXPRESSED OR IMPLIED, AND OF ALL OTHER OBLIGATIONS OR LIABILITIES ON OUR PART, INCLUDING THE IMPLIED WARRANTY OF MERCHANTABILITY. THERE ARE NO WARRANTIES WHICH EXTEND BEYOND THE DESCRIPTION ON THE FACE HEREOF. In no event shall Gold Medal Products Co. be liable for special, incidental or consequential damages. No claim under this warranty will be honored if the equipment covered has been misused, neglected, damaged in transit, or has been tampered with or changed in any way. No claim under this warranty shall be honored in the event that components in the unit at the time of the claim were not supplied or approved by Gold Medal Products Co. This warranty is effective only when electrical items have been properly attached to city utility lines only at proper voltages. This warranty is not transferable without the written consent of Gold Medal Products Co.

The term "Original Purchaser" as used in this warranty shall be deemed to mean that person, firm, association, or corporation who was billed by the GOLD MEDAL PRODUCTS CO., or their authorized distributor for the equipment.

THIS WARRANTY HAS NO EFFECT AND IS VOID UNLESS THE ORIGINAL PURCHASER FIRST CALLS GOLD MEDAL PRODUCTS CO. AT 1-800-543-0862 TO DISCUSS WITH OUR SERVICE REPRESENTATIVE THE EQUIPMENT PROBLEM, AND, IF NECESSARY, FOR INSTRUCTIONS CONCERNING THE REPAIR OR REPLACEMENT OF PARTS.

NOTE: This equipment is manufactured and sold for commercial use only.



GOLD MEDAL[®] PRODUCTS CO.

10700 Medallion Drive, Cincinnati, Ohio 45241-4807 USA

gmpopcorn.com

Phone: (800) 543-0862 Fax: (800) 542-1496
(513) 769-7676 (513) 769-8500