



Instruction Manual

Karmel King - Digital

Model No. 2620D, 2621D, 2630D, 2631D
2620DT, 2621DT, 2630DT, 2631DT



GOLD MEDAL® PRODUCTS CO.

10700 Medallion Drive, Cincinnati, Ohio 45241-4807 USA

SAFETY PRECAUTIONS

	⚠ DANGER
	<p>Machine must be properly grounded to prevent electrical shock to personnel. Failure to do so could result in serious injury, or death. Make sure all machine switches are in the OFF position before plugging the equipment into the receptacle. Keep cord and plug off the ground and away from moisture. Always unplug the equipment before cleaning or servicing. DO NOT immerse any part of this equipment in water. DO NOT use a water jet or excessive water when cleaning.</p> <p>008_012221</p>

	⚠ DANGER
	<p>Improper installation, adjustment, alteration, service, or maintenance can cause property damage, injury, or death. Any alterations to this equipment will void the warranty and may cause a dangerous condition. This appliance is not intended to be operated by means of an external timer or separate remote-control system. NEVER make alterations to this equipment. Read the Installation, Operating, and Maintenance Instructions thoroughly before installing, servicing, or operating this equipment.</p> <p>014_020416</p>



	⚠ WARNING
	<p>To avoid burns, DO NOT touch the kettle or any heated surface. DO NOT place or leave objects in contact with heated surfaces.</p> <p>013_092414</p>



	⚠ WARNING
	<p>ALWAYS wear safety glasses when servicing this equipment.</p> <p>010_010914</p>

	⚠ WARNING
	<p>No user serviceable parts inside. Refer servicing to qualified service personnel.</p> <p>011_051514</p>

	⚠ WARNING
	<p>Read and understand operator's manual and all other safety instructions before using this equipment. To order copies of the operator's manual go to gmpopcorn.com or write to Gold Medal Products Co., 10700 Medallion Drive, Cincinnati, OH 45241 USA 1-(800)-543-0862</p> <p>022_060215</p>



	 WARNING
	DO NOT allow direct contact of this equipment by the public when used in food service locations. Only personnel trained and experienced in the equipment operation may operate this equipment. Carefully read all instructions before operation. 012_010914

	 WARNING
	This machine is NOT to be operated by minors. 007_010914

	 CAUTION
	If the supply cord is damaged, it must be replaced by Gold Medal Products Co., its service agent or similarly qualified persons in order to avoid a hazard. 039_080614

Note: Improvements are always being made to Gold Medal's equipment. This information may not be the latest available for your purposes. It is critical that you call Gold Medal's Technical Service Department at 1-800-543-0862 for any questions about your machine operations, replacement parts, or any service questions. (Gold Medal Products Co. does not assume any liability for injury due to careless handling and/or reckless operation of this equipment.) General images may be used in manual for reference only.

INSTALLATION INSTRUCTIONS

Inspection of Shipment

After unpacking, check thoroughly for any damage which may have occurred in transit. Claims should be filed immediately with the transportation company. The warranty does not cover damage that occurs in transit, or damage caused by abuse, or consequential damage due to the operation of this machine, since it is beyond our control (reference warranty in back of manual).

Manual

Read and understand the operator's manual and all other safety instructions before using this equipment. To order copies of the operator's manual go to gmpopcorn.com or write to Gold Medal Products Co., 10700 Medallion Drive, Cincinnati, OH 45241 USA 1-(800)-543-0862.

Model Description

The Digital Mark 20 Corn Treat Unit has a 20 gallon capacity and is available with either right hand or left hand dump capability (see below for unit description). For electrical specifications, refer to the Electrical Requirements section of this manual.

240 Volt Corn Treat Units

2620D: Mark 20 with Digital Heat Control, Right Hand Dump

2620DT: Mark 20 with Digital Heat Control, Right Hand Dump, and Dual Timer

2621D: Mark 20 with Digital Heat Control, Left Hand Dump

2621DT: Mark 20 with Digital Heat Control, Left Hand Dump, and Dual Timer

208 Volt Corn Treat Units

2630D: Mark 20 with Digital Heat Control, Right Hand Dump

2630DT: Mark 20 with Digital Heat Control, Right Hand Dump, and Dual Timer

2631D: Mark 20 with Digital Heat Control and Left Hand Dump

2631DT: Mark 20 with Digital Heat Control, Left Hand Dump, and Dual Timer

Items Included with this Unit



Setup

1. Remove all packaging and tape, and accessories before starting operation.
2. This unit must be properly fastened to a sturdy counter, see illustration below for counter mounting requirements.

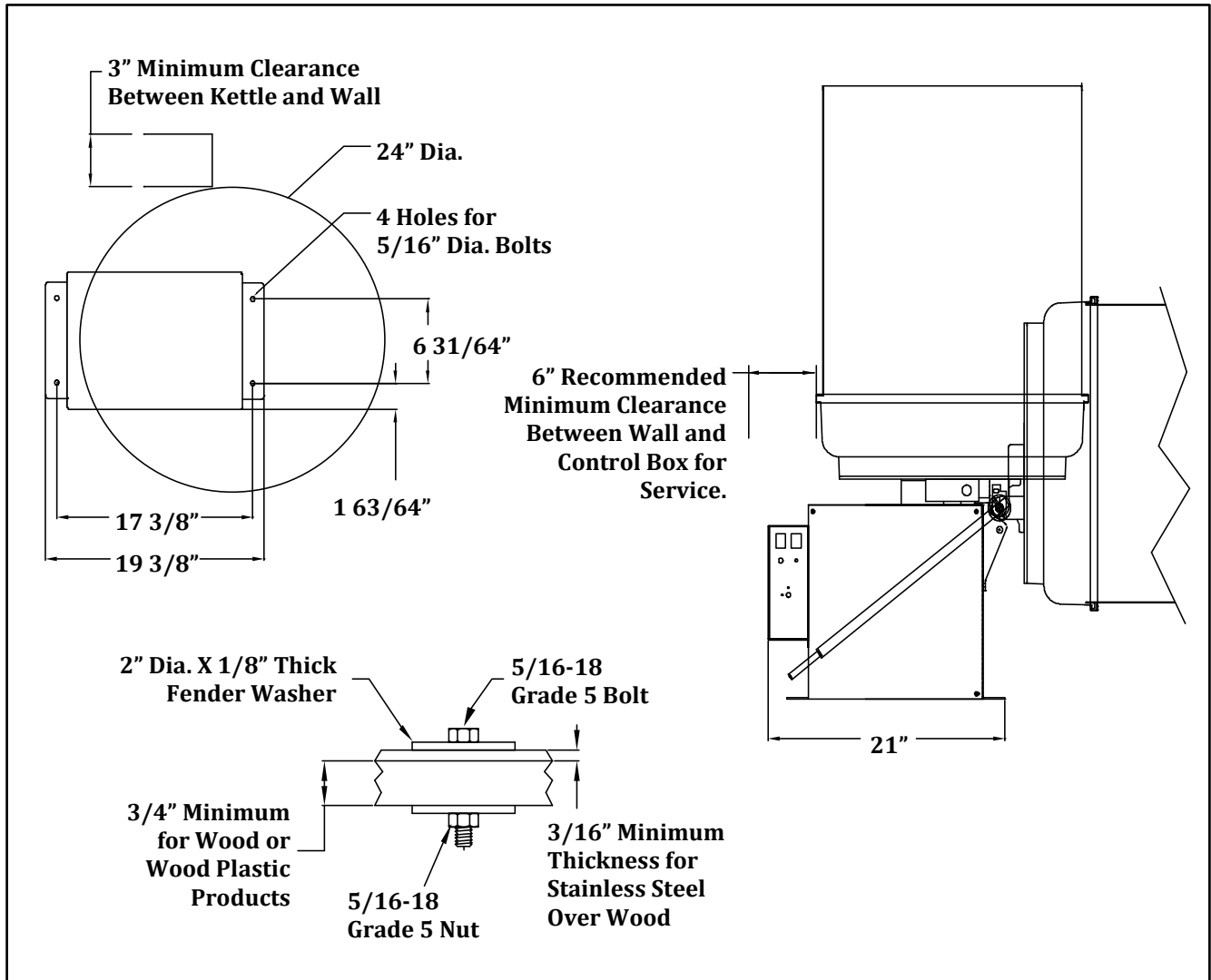

Paddle and Drum Assembly

1. Prior to operation, rotate the top paddle from the shipping position into the mix position—reference images on next page for paddle and drum assembly:
 - a) Pull plunger knob out and lift paddle into position.
 - b) When positioned, release knob and make sure the plunger securely sets into its hole in the shaft to lock the paddle in place.
2. After setup, the unit should be cleaned prior to use (see Care and Cleaning section).

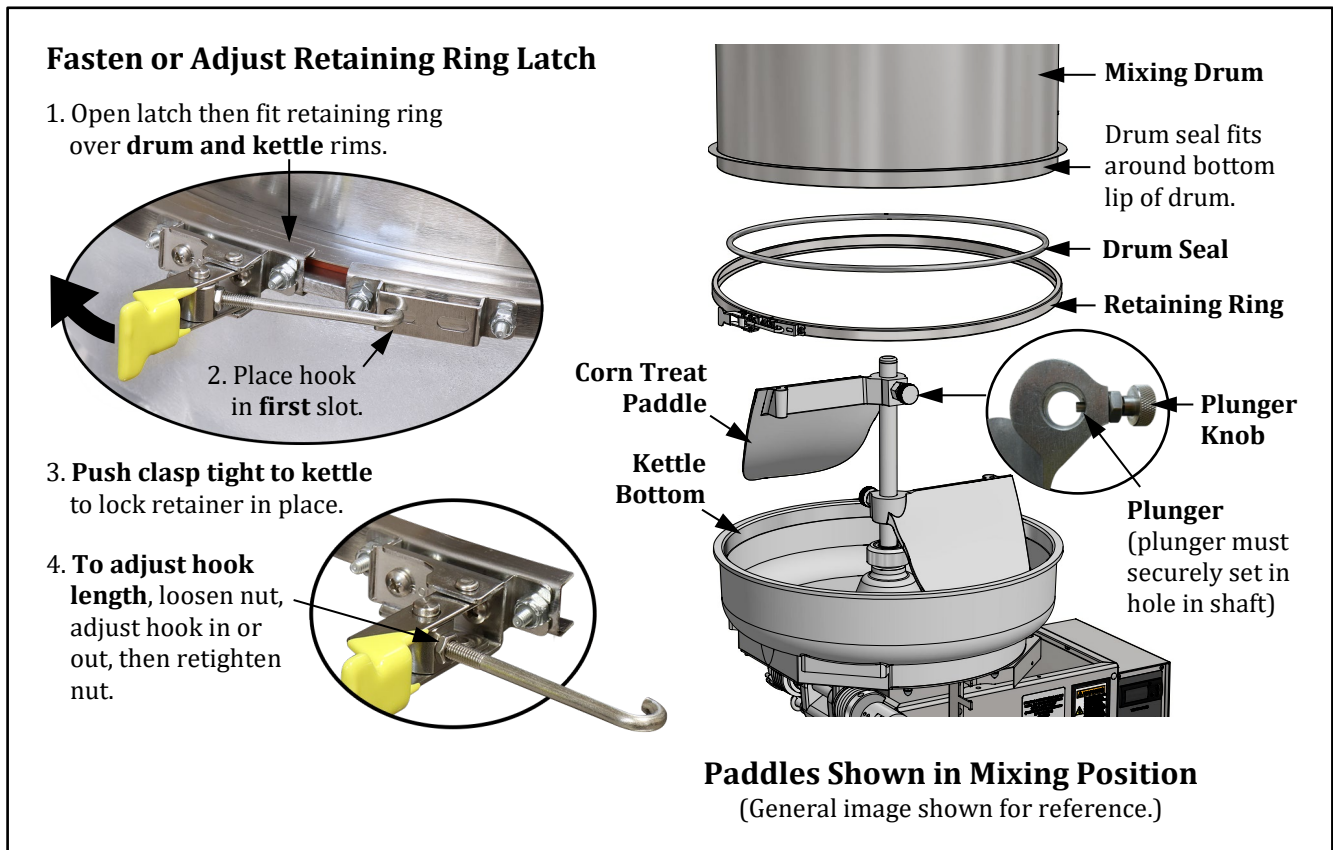

Electrical Requirements

The following power supply must be provided (reference unit Data Plate for Wattage requirement):

2620D, 2620DT, 2621D, 2621DT: 240 V~, 60 Hz

2 wire plus ground, single phase. The machine is rated for 28.2 amps. A wall receptacle is supplied with the machine. This receptacle will accept the attachment plug on the machine and must be used.

2630D, 2630DT, 2631D, 2631DT: 208 V~, 60 Hz

2 wire plus ground, single phase. The machine is rated for 31.7 amps. A wall receptacle is supplied with the machine. This receptacle will accept the attachment plug on the machine and must be used.

	⚠ DANGER
	<p>Machine must be properly grounded to prevent electrical shock to personnel. Failure to do so could result in serious injury, or death. Make sure all machine switches are in the OFF position before plugging the equipment into the receptacle. Keep cord and plug off the ground and away from moisture. Always unplug the equipment before cleaning or servicing. DO NOT immerse any part of this equipment in water. DO NOT use a water jet or excessive water when cleaning.</p> <p style="text-align: right; font-size: 0.8em;">008_012221</p>

A certified electrician must furnish sufficient power for proper machine operation and install any supplied receptacle (reference unit Data Plate for model specific Volts AC, Hertz, and Wattage



requirements). We recommend this equipment be on a dedicated and protected circuit. Failure to wire properly will void the warranty and may result in damage to the machine. It is Gold Medal Products Co.'s recommendation that this machine be plugged directly into a wall outlet. The use of extension cords is not recommended due to safety concerns, and may cause sacrificed and/or reduced performance. Make sure cord is located to prevent a trip hazard or unit upset.

Before You Plug In Machine

1. Make sure all machine switches are OFF before plugging equipment into receptacle.
2. Make sure wall outlet can accept the grounded plugs (where applicable) on the power supply cord.
3. The wall outlet must have the proper polarity. If in doubt, have a competent electrician inspect the outlet and correct if necessary.
4. **DO NOT** use a grounded to un-grounded receptacle adapter (where applicable).
5. Install unit in a level position.



OPERATING INSTRUCTIONS

Controls and Their Functions

HEAT/MOTOR SWITCH

Two position, ON/OFF lighted rocker switch – provides power to the heating elements in the bottom of the kettle, and powers the agitator motor to turn for 30 seconds of every minute. The green switch light ON indicates there is power to these features.

Note: It is normal for the motor to stop for 30 seconds of every minute (when the Motor Only Switch is OFF).

MOTOR ONLY SWITCH

Two position, ON/OFF lighted rocker switch – provides power to the agitator motor to run continuously.

Note: The main function of this switch is for mixing the product/popcorn at the end of the cooking cycle with the kettle in the tilt position, and it is used for “cleaning mode”.

15 AMP FUSE

The 15 AMP Fuse protects the Motor and Heat Control from an overload condition.

KETTLE DUMP HANDLE

The Kettle Dump Handle tilts the kettle from the upright cook position to the mix position or the dump position. The 2 position bracket holds the handle in the tilted position.

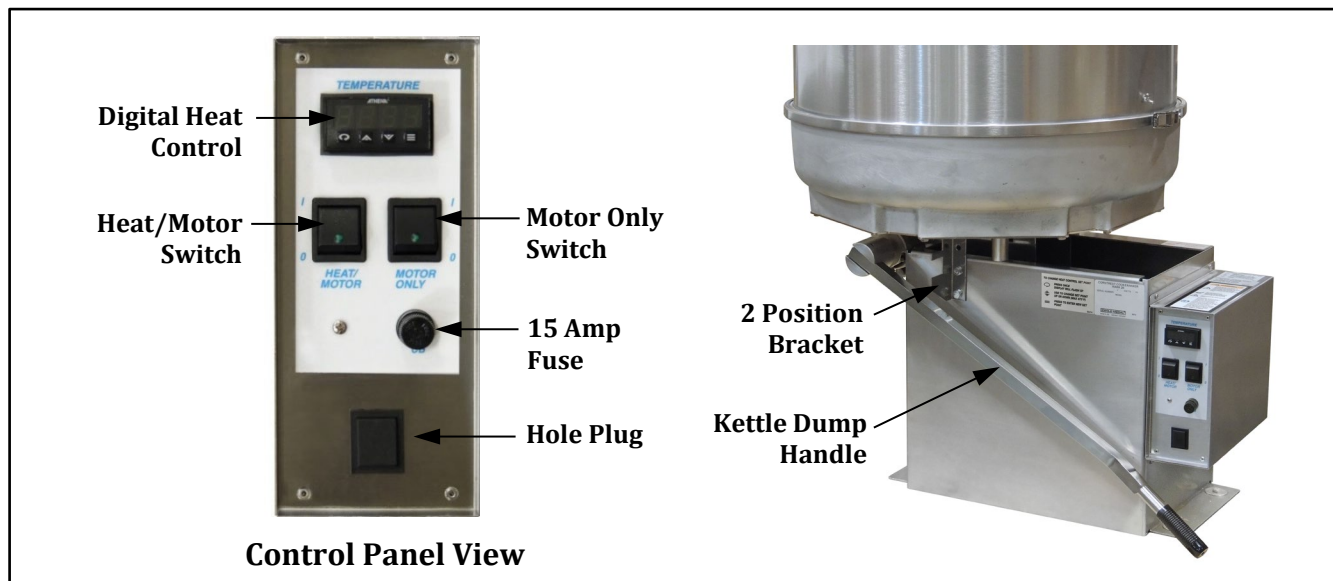

Control Panel View





DIGITAL HEAT CONTROL

The Digital Heat Control adjusts the Set Point Temperature of the unit. The machine comes from the factory preset to achieve a Product Cook Temperature of 280°F. See Digital Heat Control Adjustment/Calibration section for adjusting the Product Cook Temperature.

D Models: The sound of the buzzer signals kettle heat shut-off. The buzzer will continue to sound until the unit is turned off or until the unit temperature falls below set point.

DT Models: Dual Timer units. The pre-alarm sounds the buzzer 40°F before Set Point Temperature; alerting operator that flavor can be added to the mix (the kettle will continue to heat the mixture). The second buzzer sounds kettle heat shutoff at a Product Cook Temperature of 280°F. Each buzzer only sounds for 10-15 seconds.

Buttons/Indicator Light Descriptions

UP Button / DOWN Button   – adjusts the Set point Temperature UP or DN when in programming mode.

Access Button  – accesses programming mode to change Set Point Temperature, see Heat Control Adjustment section.

Mode Button  – exits programming mode and locks in adjustments, see Digital Heat Control Adjustment section.

Digital Display – display shows temperature of the kettle; this is not the same as the product temperature. (Reference the Digital Heat Control Adjustment/Calibration section.)

Heat Indicator Light – light is ON when the unit is heating. See image below for D Model and DT Model indicator descriptions.

Buzzer Indicator Light – See image below for D Model and DT Model indicator light description.

Heat Indicator Light (D Models)

Light is ON when the unit is heating. It goes OFF when the buzzer sounds (signaling heat shut-off).



Buzzer Indicator Light (D Models)

Light comes ON when the buzzer sounds (signaling heat shut-off).

Digital Heat Control (D Models)

Heat Indicator Light (DT Models)

Light is ON when the unit is heating. It stays on until the **second** buzzer sounds (signaling heat shut-off).



Buzzer Indicator Light (DT Models)

Light is ON until the **first** buzzer sounds (pre-alarm), and then the light goes OFF.

Dual Timer Control (DT Models)

Digital Heat Control Adjustment/Calibration

Product Cook Temperature is the actual temperature of the PRODUCT (Caramel Corn Mix); this is measured with an accurate candy thermometer. Infrared temperature readers are NOT recommended.



Set Point Temperature is the temperature setting of the KETTLE; this is the temperature needed to get the Caramel Corn Mix up to the finished Product Cook Temperature of 280°F. The digital display shows the kettle temperature, NOT the product temperature.

Note: The Set Point Temperature will be higher than the product temperature. Refer to the candy thermometer for accurate product temperature.

Digital Heat Control Adjustment

The machine comes from the factory preset to achieve a **Product Cook Temperature** of 280°F. Small adjustments may need to be made for mix used or cooking conditions. If the product is ready, either before or after the buzzer sounds, then follow the steps listed to increase or decrease the **Set Point Temperature** of the kettle:

Note: D Models - The sound of the buzzer signals kettle heat shut-off.
DT Models - The sound of the second buzzer signals kettle heat shut-off.

1. To change the Set Point Temperature, press the  key. The display shows **SP** followed by a temperature number flashing. Use the arrow keys to set the desired temperature.
2. Once the temperature is set, press the  key to lock in the new temperature.

Digital Heat Control Calibration (Performed at the Factory)

This unit has been calibrated at the factory. Other than small adjustments made for mix used or cooking conditions (see above Digital Heat Control Adjustment), the unit is ready for use and should not need calibration.

To reset the Digital Heat Control back to factory settings follow the procedure shown below.

Note: For calibration purposes only, corn oil is used to determine the Digital Heat Control temperature setting which will produce an accurate finished product temperature of 280°F.

1. Start with a clean unit, which is cool before attempting to calibrate.
2. Fill the mixing bowl with a one inch depth of corn oil.
3. Turn the Heat/Motor Switch ON.
4. Use an accurate candy thermometer to measure the temperature of the oil in the mixing bowl. (Infrared temperature readers are NOT recommended.)



5. Set the digital control set point temperature to 400°F.
6. Turn the Motor Only Switch ON to stir the oil while it heats.
7. When the oil reaches 335°F, note the temperature displayed on the digital control and make that the Set Point Temperature.

**Note: The Set Point Temperature will be higher than the product temperature.
Refer to the candy thermometer for accurate product temperature.**

8. Allow oil to cool below 300°F, then repeat Step 5 to check the buzzer sounds at 335°F.
9. The unit is now calibrated for the heat control buzzer to sound at a finished product temperature of 280°F.

Caution: Allow hot oil to cool below 140°F before attempting to drain.



Making Caramel Corn

Instructions for Making Caramel Corn (Mark 20)

Always remember—leave the lid on the kettle during the first part of the batch. Once steam starts to “roll-up” from under the lid, carefully remove the lid for remainder of the cooking cycle.

CAUTION: Beware of rising steam; keep face and hands clear of rising steam.

1. Turn Heat/Motor Switch ON (leave Motor Only Switch OFF).
2. Add (4) 22 oz. packages of Gold Medal Caramel Corn Mix (Item No. 2094), 16 cups of granulated sugar (brown or white), and 32–48 oz. of water (add water last).
Note: If using Gold Medal “One Step” Caramel Corn Mix, **DO NOT** add granulated sugar.
3. Turn Motor Only Switch ON—mix approx. 1 minute, then turn Motor Only Switch OFF.
(With the Heat/Motor Switch still ON—motor will run for 30 sec. of every minute.)
4. Add 16 oz. of coconut oil or vegetable oil. Put on the lid.
Note: Once steam starts to “roll-up” from under the lid, carefully remove lid for remainder of cooking cycle.
5. Allow mix to cook until buzzer sounds at 280°F product temperature.
Dual Timer Units: When the first buzzer sounds, add flavor mixture (if desired), the unit will continue to heat until the second buzzer sounds at 280°F product temperature.
Note: Product temperature is measured with an accurate candy thermometer.
(Reference the Heat Control Adjustment section.)
6. Turn Heat/Motor Switch OFF.
7. Turn Motor Only Switch ON.
8. Add 20 gallons of pre-popped corn.
9. Allow corn to mix for approx. 10 seconds with kettle in upright position.
10. Move kettle to mix position and spray 20–30 “squirts” of Gold Medal Free-N-Easy (Item No. 2250) on caramel corn to help separation—mix popcorn until thoroughly coated.
11. Dump caramel corn into a cooling pan—mix and separate the caramel corn using two popcorn scoops.
12. After dumping, turn Motor Only Switch OFF.
13. Allow finished product to cool before packaging.

During normal operation, sugar builds up in the kettle and it must be removed (reference Kettle Cleaning Procedure in the Care and Cleaning section.):

- Steam the kettle every 3–4 batches to remove sugar build-up.
- Steam the kettle after making single batches if unit is turned off between batches.
- **Steam the kettle before turning unit off for the day.**

Care and Cleaning

	⚠ DANGER
	Machine must be properly grounded to prevent electrical shock to personnel. DO NOT immerse in water. DO NOT clean appliance with a water jet or steam cleaner. Always unplug the equipment before cleaning or servicing. 025_051321

	⚠ WARNING
	To avoid serious burns, DO NOT touch the kettle while it is hot! 028_082715

Good sanitation practice demands that all food preparation equipment be cleaned regularly—only use non-toxic, food grade cleaners.

For surfaces needing further cleaning or degreasing, Watchdog Stainless Cleaner (Item No. 2088) or Watchdog Concession Equipment Degreaser (Item No. 2580) is available for use accordingly. For any cleaning products used, follow the manufacturer's instructions on the product. **DO NOT use oven cleaners or abrasive materials** as they will damage parts of machine.

Note: It is extremely important to follow all cleaning procedures, otherwise parts damage and equipment failure will result. The warranty does not cover parts that are damaged due to improper cleaning.

Kettle Cleaning Procedure

Follow procedure below to steam sugar build-up out of the kettle every 3-4 batches during regular operation and before turning the unit off for the day. Steam kettle out **after every batch** if the unit is turned off between batches.

1. After all product has been removed and the kettle has cooled 15-20 minutes, carefully pour 24 oz. of water into kettle.
CAUTION: Beware of rising steam; keep face and hands clear of rising steam.
2. Place lid on kettle and turn Heat/Motor Switch ON.
3. When water starts to boil, turn Heat/Motor Switch OFF.
4. Turn Motor Only Switch ON and allow unit to cool, then remove lid and carefully pour kettle contents into a pan/bucket. Steam kettle twice to help remove all traces of product.
5. Turn Motor Only Switch OFF.
6. With all switches OFF, wipe out any sugar build-up remaining in kettle using a clean damp rag, then kettle is ready to begin another batch.
7. Do not leave water in kettle or pan overnight—clean pans/bucket for next use.



Daily Unit Cleaning Procedure

1. Turn machine OFF, unplug the unit and allow it to cool before attempting to clean.
2. Clean all pans/accessories after each use.
3. Release draw latch and remove mixing drum, then remove paddles (pull plunger knob and lift paddle off).
Take drum and paddles to sink and clean with soap and water, then rinse and dry.
4. With unit OFF and unplugged, use a clean SLIGHTLY damp cloth (wring ANY EXCESS water from cloth before use) and wipe the kettle lead cord clean. **DO NOT get moisture into the kettle lead-in cord, severe damage will result.**
5. Wipe unit clean using a cloth SLIGHTLY dampened with soap and water, then wipe again to remove any remaining cleaner.

Weekly Cleaning of the Hub Seal Assembly

Important: Keep the hub seal and o-rings clean for proper machine performance.

1. Turn machine OFF, unplug the unit and allow it to cool.
2. Pull knurled knob of plunger and lift mix paddles off shaft.
3. Remove any burrs on the shaft using a fine grit emery paper to lightly sand the surface—burrs can damage the o-ring/oil seal during removal/installation.
4. Remove the hub seal assembly and soak it in hot water to clean.
5. Clean out any sanding partials from kettle and shaft.
6. Clean the area around the center hub. Remove any product residue. (See Kettle Shaft Maintenance section for note on lubricating the kettle bushings.)
7. Lightly lubricate the center hub of the kettle with a small amount of Petro Gel to allow for easy re-installation of the hub seal assembly.
8. Slide the clean hub seal assembly down the agitator shaft. Apply pressure to ease the assembly over the center hub of the kettle until it seats properly.
9. Re-install the mix paddles—make sure the plunger of each paddle securely sets into its hole in the shaft.

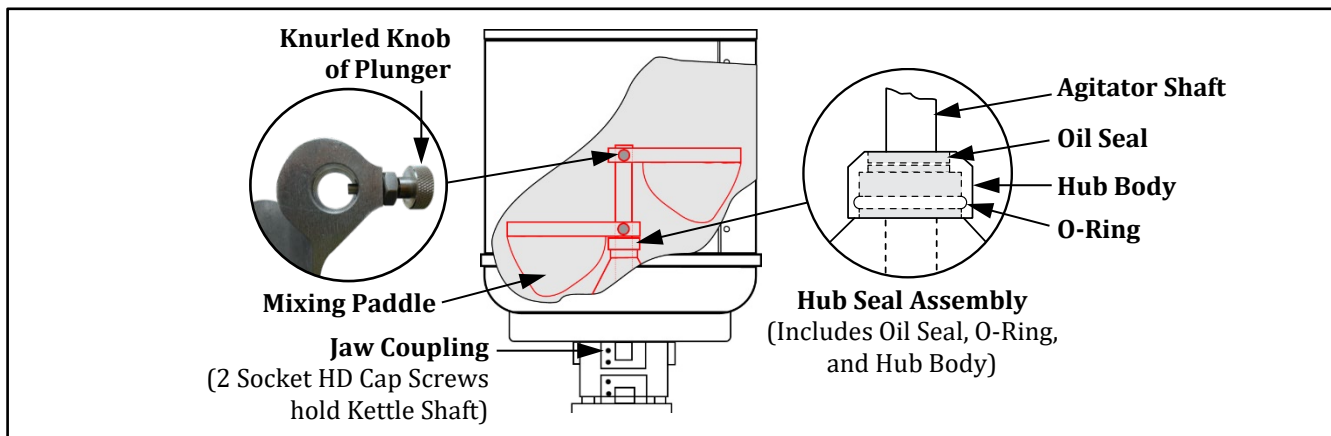





Troubleshooting



Issue	Possible Cause	Solution
Kettle Does Not Heat	<p>A. Power to Unit</p> <p>B. 15 AMP Fuse</p> <p>C. Kettle Heat/Motor Switch</p> <p>D. Control</p>	<p>A. Make sure the unit lead-in cord is plugged in.</p> <p>B. Check the condition of the 15 AMP fuse. Replace if required, if fuse trips again, contact qualified service personnel for inspection/repair before going any further.</p> <p>C. Have qualified service personnel check the voltage to and from the Heat/Motor Switch; if switch is defective, replace it.</p> <p>D. A defective sensor lead will cause the kettle not to heat. Have qualified service personnel check for good connections from the kettle to the control.</p>
Indicator Lights ON or OFF at incorrect time.	A. Control Indicator Lights (Reference Controls and Their Functions section for indicator light descriptions.)	<p>A. D Models - The Heat Indicator Light and the Buzzer Indicator Light should NOT be on at the same time. Contact qualified service personnel for inspection/repair.</p> <p>DT Models - If the Buzzer Indicator Light goes out and the pre-alarm is not sounding, contact qualified service personnel for inspection/ repair.</p>
Error Code on Digital Display	A. Digital display error code Err.H or Err.L	<p>A. Have qualified service personnel check the RTD resistance value (should read approx. 110 ohms at room temperature); also check for shorts or opens.</p> <p>If RTD resistance value is OK and there are no shorts or opens, then replace digital temperature control.</p>
Kettle Agitator Does Not Turn	A. Kettle Agitator Shaft/Motor Shaft	A. If the kettle agitator shaft is not rotating, DO NOT use. Have qualified service personnel inspect/repair as needed.
Long Cooking Cycles	<p>A. Heating Element</p> <p>B. Low Voltage</p>	<p>A. One of the heating elements in the kettle may be burned out. This would result in the kettle never reaching the proper operating temperature. Contact qualified service personnel for inspection/repair.</p> <p>B. Unit is designed to make approximately 3 batches per hour when operated at full voltage. To get unit warmed up, the first batch usually takes about 5 minutes longer. If machine is operated on low voltage, the kettle will not reach the proper operating temperature causing longer cooking cycles.</p> <p>208 V units need 197 V minimum. 240 V units need 228 V minimum.</p>
Long Cooking Cycles	C. Inadequate Supply Lines	C. Inadequately sized electrical supply lines, in addition to being a fire hazard, would also prevent the kettle from reaching the proper operating temperature. Check with a qualified electrician.





—THE FOLLOWING SECTIONS ARE FOR QUALIFIED SERVICE PERSONNEL ONLY—

MAINTENANCE INSTRUCTIONS

	 DANGER
	<p>Machine must be properly grounded to prevent electrical shock to personnel. Failure to do so could result in serious injury, or death. Make sure all machine switches are in the OFF position before plugging the equipment into the receptacle. Keep cord and plug off the ground and away from moisture. Always unplug the equipment before cleaning or servicing. DO NOT immerse any part of this equipment in water. DO NOT use a water jet or excessive water when cleaning.</p> <p>008_012221</p>

	 DANGER
	<p>Improper installation, adjustment, alteration, service, or maintenance can cause property damage, injury, or death. Any alterations to this equipment will void the warranty and may cause a dangerous condition. This appliance is not intended to be operated by means of an external timer or separate remote-control system. NEVER make alterations to this equipment. Read the Installation, Operating, and Maintenance Instructions thoroughly before installing, servicing, or operating this equipment.</p> <p>014_020416</p>

	 WARNING
	<p>No user serviceable parts inside. Refer servicing to qualified service personnel.</p> <p>011_051514</p>

	 CAUTION
	<p>THE FOLLOWING SECTIONS OF THIS MANUAL ARE INTENDED ONLY FOR QUALIFIED SERVICE PERSONNEL WHO ARE FAMILIAR WITH ELECTRICAL EQUIPMENT. THESE ARE NOT INTENDED FOR THE OPERATOR.</p> <p>027_010914</p>

New Paddle/Hub Seal Kit Installation Kettle Shaft Maintenance

1. With the machine OFF, unplug the unit and allow it to cool.
2. Pull knurled knob of plunger and lift mix paddles off shaft.
3. Remove the old hub seal assembly.
4. Remove any burrs on the shaft using a fine grit emery paper to lightly sand the surface—burrs can damage the o-ring/oil seal during removal/installation.
5. Clean any sanding partials from kettle and shaft.
6. Clean the area around the center hub. Remove any product residue.

Monthly Shaft Maintenance: Remove the kettle shaft monthly and lubricate the kettle bushings with white food grade Never Seez® **ONLY**, then reinstall the shaft.

To remove the shaft, loosen the (2) socket head cap screws in the jaw coupling, then remove the shaft. **DO NOT lose the shaft key, it must be reset into place.**

7. Lightly lubricate the center hub of the kettle with a small amount of Petro Gel to allow for easy installation of the hub seal assembly.
8. Slide the new hub seal assembly down the agitator shaft. Apply pressure to ease the assembly over the center hub of the kettle until it seats properly (see image below).
9. After installing the hub seal, re-install the mix paddles.
Note: Make sure the plunger of each paddle securely sets into its hole in the shaft.
10. Rotate the shaft by hand to make sure the paddle does not touch the kettle bottom; re-adjust shaft if needed.

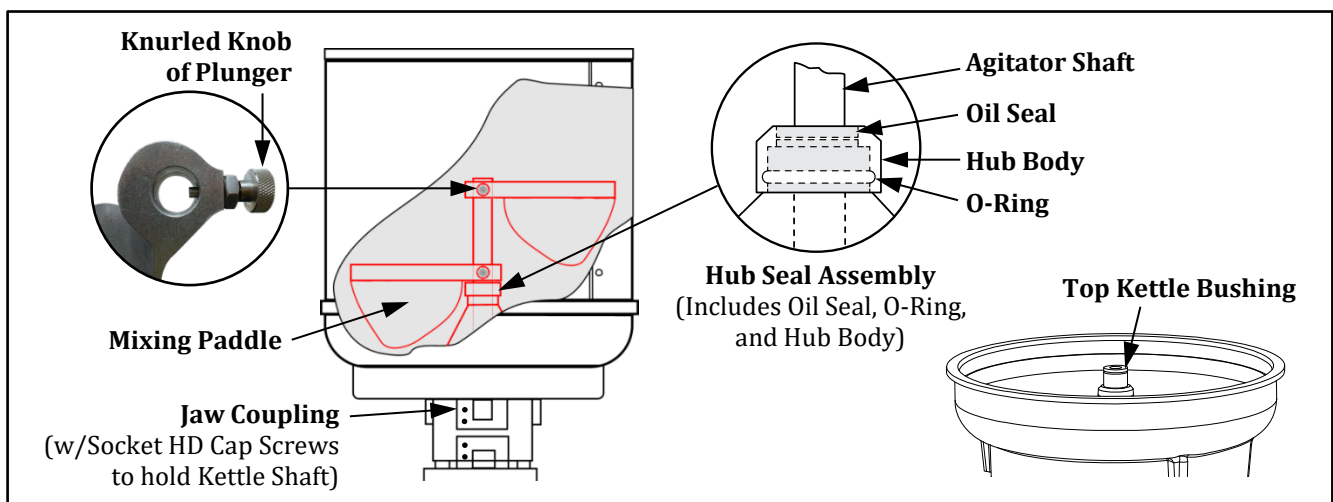



ORDERING SPARE PARTS

1. Identify the needed part by checking it against the photos, illustrations, and/or parts list. (General images may be used in manual for reference only.)
2. Use only approved replacement parts when servicing this unit.
3. When ordering, please include part number, part name, and quantity needed.
4. Please include your model number, serial number, and date of manufacture (located on the machine nameplate/data plate) with your order.
5. Address all parts orders to Parts Department, Gold Medal Products Co., 10700 Medallion Drive, Cincinnati, Ohio 45241-4807

or place orders by phone or online:

Phone: (800) 543-0862
(513) 769-7676

Fax: (800) 542-1496
(513) 769-8500

E-mail: info@gmpopcorn.com
Web Page: gmpopcorn.com



Item	Parts Description	Part Number
		All Models
1	LID ASSEMBLY	48827
2	2 POSITION BRACKET	46153
3	1/4-20 X 3/4 GRADE 5 BOLT	74520
4	1/4-20 SERRATED LOCK NUT	46311
5	CONTROL BOX COVER	55453
6	8-32 X 1/4 PHIL PAN M/S	87314

Cabinet Exterior/Spring Assembly – Parts Breakdown

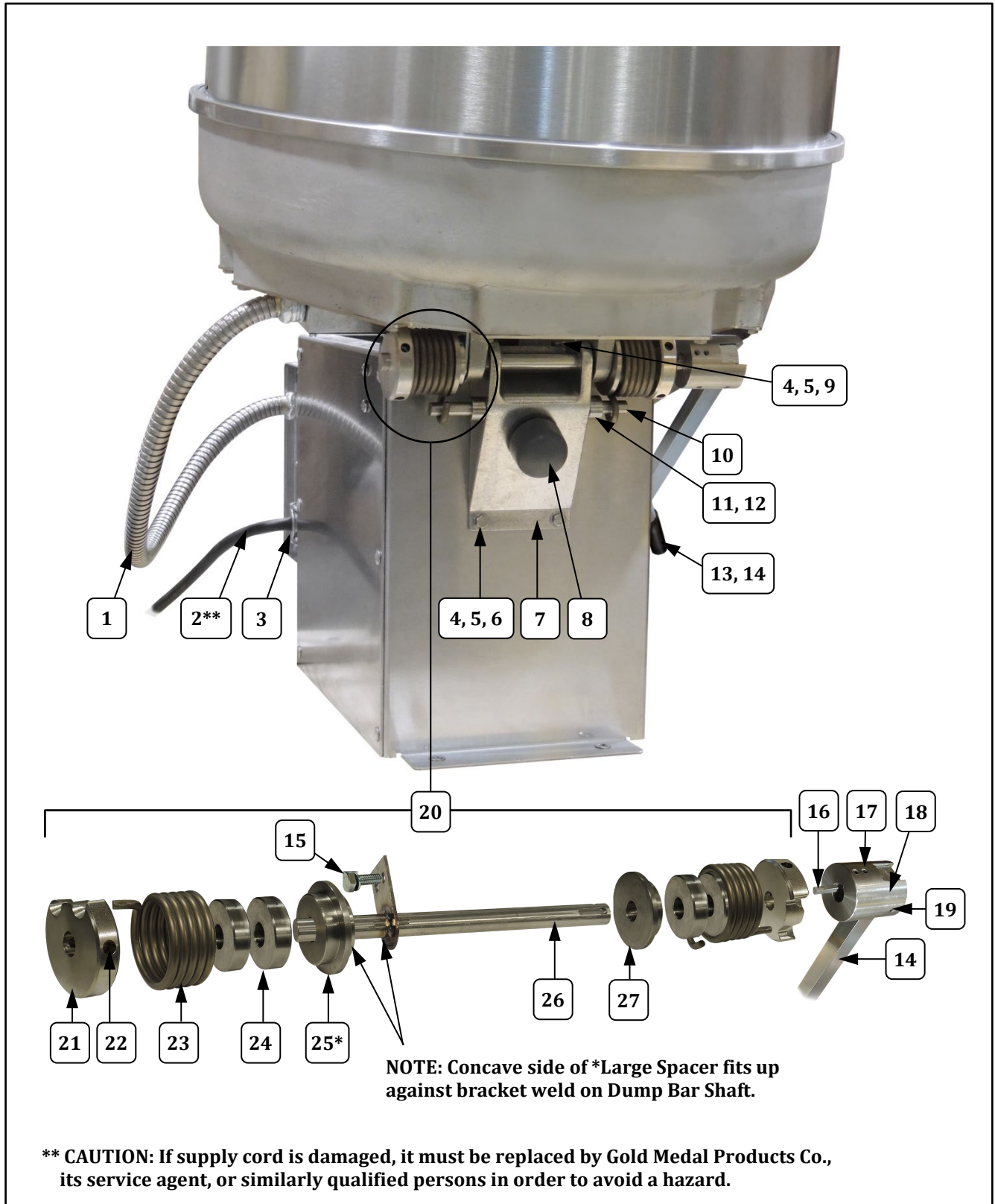



Cabinet Exterior/Spring Assembly – Parts List

Item	Parts Description	Part Number	
		RH Models 2620D, 2620DT 2630D, 2630DT	LH Models 2621D, 2621DT 2631D, 2631DT
1	KETTLE LEAD IN ASSY (includes connectors)	69867	69867
2**	POWER CORD, 50A PLUG	89810	89810
3	STRAIN RELIEF T&B 3304	82227	82227
4	1/4-20 X 3/4 HEX CAP 18-8	12515	12515
5	FLAT WASHER 1/4 STAINLESS	87261	87261
6	1/4-20 SERRATED LOCK NUT (top side of bracket use a 1/4-20 ESLOK Hex Nut)	46311	46311
7	KETTLE MTNG BRKT MACHINED	48812	48812
8	KETTLE STOP	70047	70047
9	HEX NUT 1/4-20 ESLOK	42361	42361
10	SPRING RETAINER ROD	82551	82551
11	SET COLLAR 1/2ID X 7/8OD	47326	47326
12	SET SCREW 1/4-20 X 3/16	47751	47751
13	GRIP, HANDLE BAR	46028	46028
14	TILT LEVER, MARK 10 CTC	46488	46488
15	1/4-20 X 3/4 GRADE 5 BOLT	74520	74520
16	KEY (.187 X .187 X 3/4)	12509	12509
17	SET SCREW 1/4-20 X 3/8	74125	74125
18	HUB	48839	48839
19	COILED SPRING PIN	48883	48883
20	RT SPRING & DUMP BAR ASSEMBLY (includes items listed below)	48842	
	LT SPRING & DUMP BAR ASSEMBLY (includes items listed below)		48882
21	COLLAR	74661	74661
22	SET SCREW, 5/16-18 X 5/8 (3 req'd. per collar)	74662	74662
23	TORSION SPRING	74660	74660
24	SPACER	74658	74658
25	SPACER, LARGE (DUMP SIDE) - Concave side fits up against bracket weld on Dump Bar Shaft	74659	74659
26*	RT DUMP BAR WELDMENT	48841	
	LEFT DUMP SHAFT WELDMENT		48881
27	SPACER,LARGE (CUSTOMER SIDE)	74690	74690

Kettle and Drum – Parts Breakdown

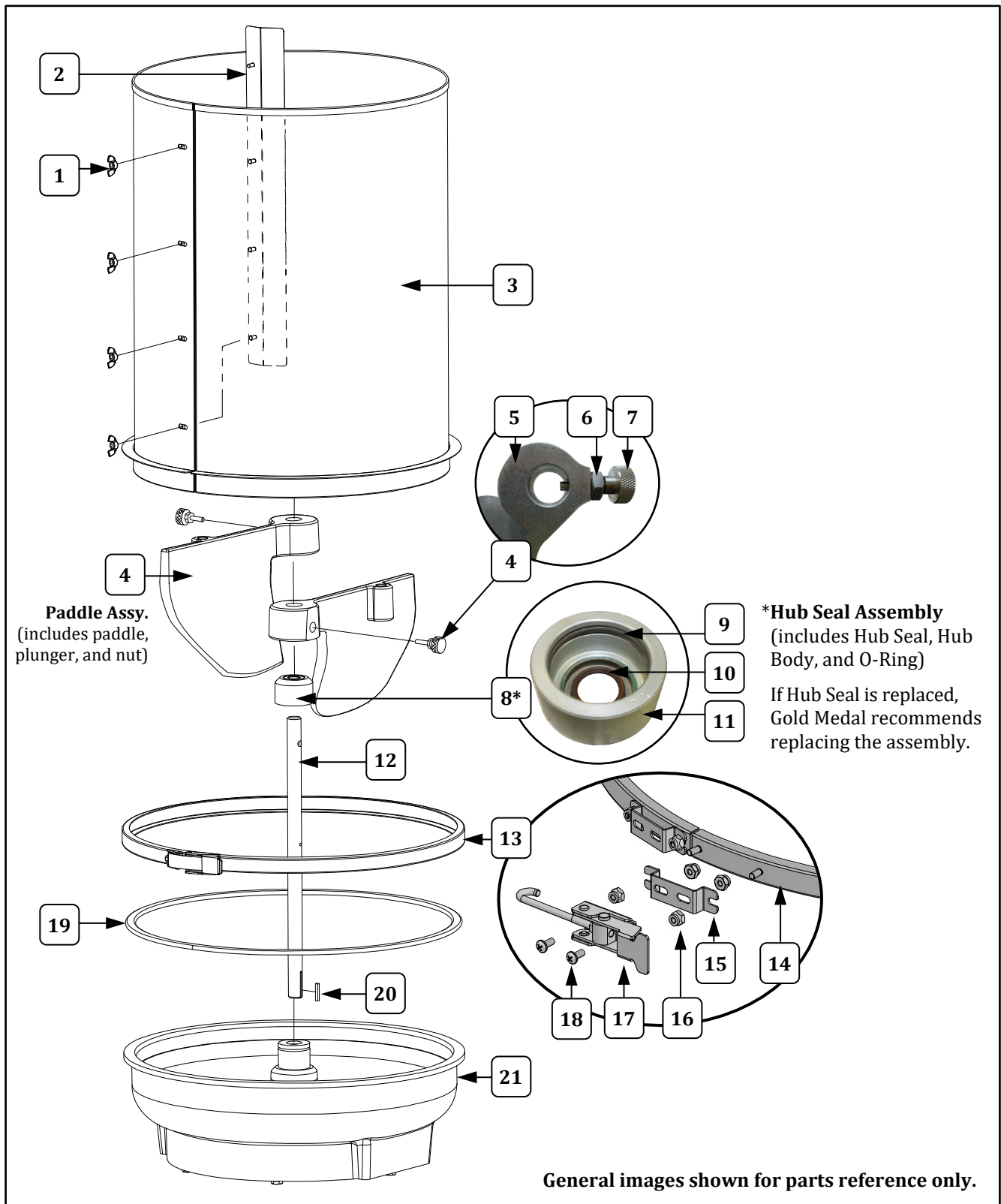



Kettle and Drum – Parts List

Item	Parts Description	Part Number
		All Models
1	WING NUT, #8-32	89126
2	BLENDING STRIP	100553
3	MIXING DRUM	48819
4	MIXER PADDLE ASSY (includes Mix Paddle, Hex Nut and Plunger)	111408
5	MIXER PADDLE MACHINED	111407
6	HEX NUT 5/8-11	111402
7	PLUNGER 5/8-11	111401
8	HUB SEAL ASSY MARK 10,20 (includes Oil Seal, Hub Body, and O-Ring)	46646
9	O-RING 1 3/4ID X 2OD	46641
10	HUB SEAL (If Hub Seal needs replacement, Gold Medal recommends replacing the assembly.)	46640
11	HUB SEAL BODY	46642
12	DRIVE SHAFT	111406
13	RETAINING RING ASSY (complete ring with latch)	114833
14	RETAINING RING SUBASSY	114834
15	DRAW LATCH BRACKET	114663
16	8-32 HEX NUT, ESLOK, S.S.	22070
17	ADJUSTABLE DRAW LATCH	114662
18	8-32 X 3/8 PAN HD PH M/S	12389
19	DRUM SEAL MARK 20	48822
20	KEY (.187 X .187 X 3/4)	12509
21	KETTLE ASSY, ELECTRONIC (includes Shaft, Hub Seal Assy, Retaining Ring and Gasket; also see Kettle Bottom and Kettle Element View sections for itemized parts breakdown).	48828

Kettle Bottom Plate/Motor Mount – Parts Breakdown

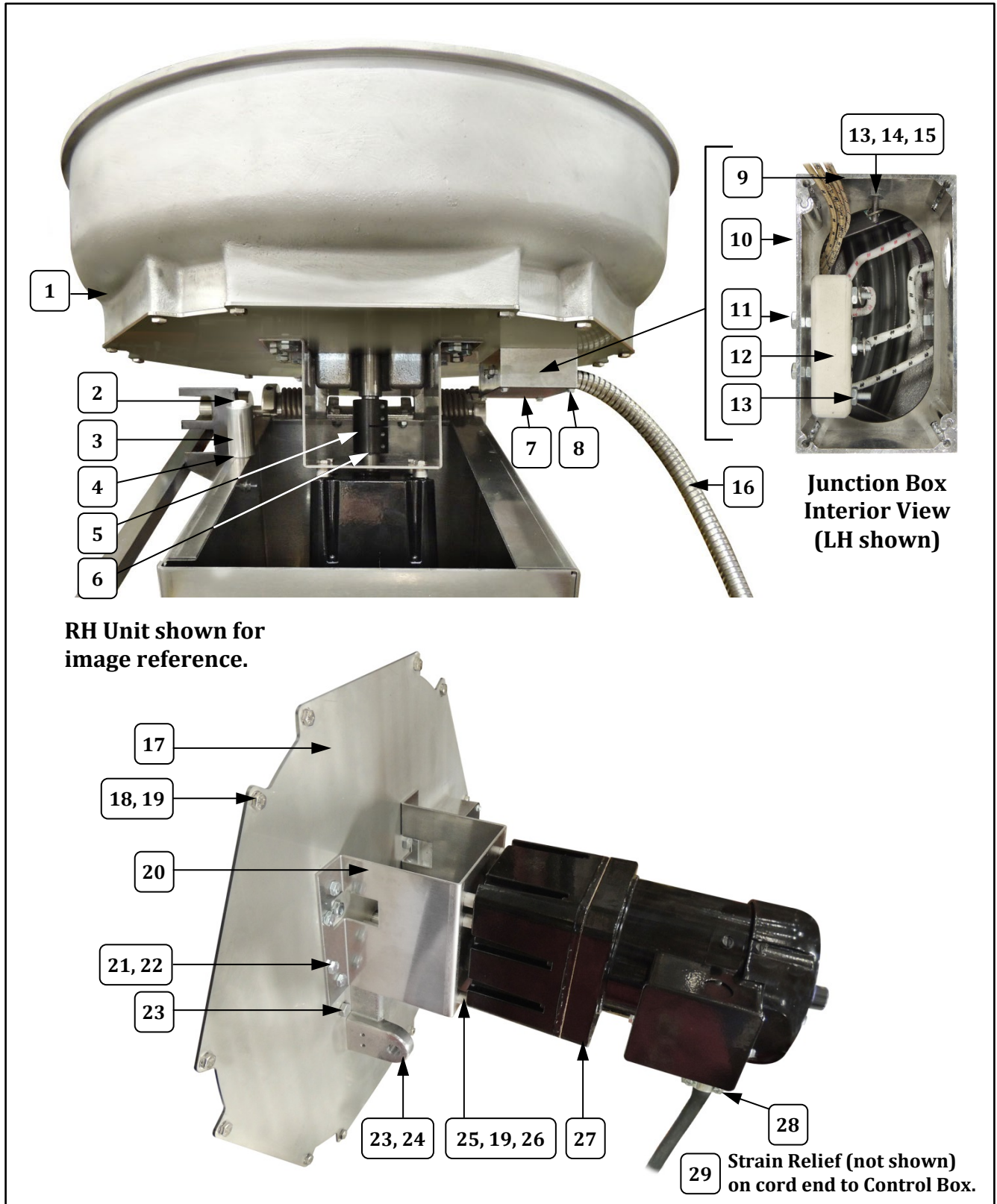



Kettle Bottom Plate/Motor Mount – Parts List

Item	Parts Description	Part Number
		All Models
1	KETTLE ASSY, ELECTRONIC (see Kettle Bottom and Kettle Element View sections for itemized parts breakdown)	48828
2	KETTLE REST BUMPER (rubber bumper)	83111
3	KETTLE REST (metal rest/holds rubber bumper)	83110
4	1/4-20 X 3/4 GRADE 5 BOLT	74520
5	DRIVE COUPLING	48826
6	.187 X .187 X 3/4 KEY	12509
7	JUNCTION BOX COVER	83262
8	8-32 X 1/2 SLOTTED H W H (screws for cover)	49379
9	JUNCTION BOX LEAD-SIDE	68875
10	JUNCTION BOX TERMINAL-SIDE	83261
11	8-32 SERRATED FLANGE NUT	61151
12	TERMINAL BLOCK KETTLE	41129
13	8-32 HEX M/S NUT	74149
14	8-32 X 3/4 PHIL PAN MS SS	39007
15	WASHER #8 INTERNAL TOOTH	74150
16	KETTLE LEAD IN ASSY (includes connectors)	69867
17	BOTTOM PLATE	48817
18	1/4-20 X 1/2 HX HD SCREW	12382
19	WASHER 1/4 INTERNAL TOOTH	12383
20	MOTOR MOUNT (Bracket)	48818
21	5/16-18 X 1/2 HHC GRADE 2	47206
22	5/16-18 SERRATED LOCK NUT	49317
23	HEX BOLT 3/8-16 X 3/4	20051
24	PIVOT CASTING MACHINED	48810
25	1/4-20 X 1 HX HD C S 18-8 (fastens motor)	12185
26	MOTOR SPACER	67207
27	1/4 HP DRIVE MOTOR (includes shaft key)	48880
28	STRAIN RELIEF T&B 3302 (Metal strain relief)	89045
29	STRAIN RELIEF (Plastic Strain Relief on cord end to Control Box)	67060

Kettle Element View - Parts Breakdown

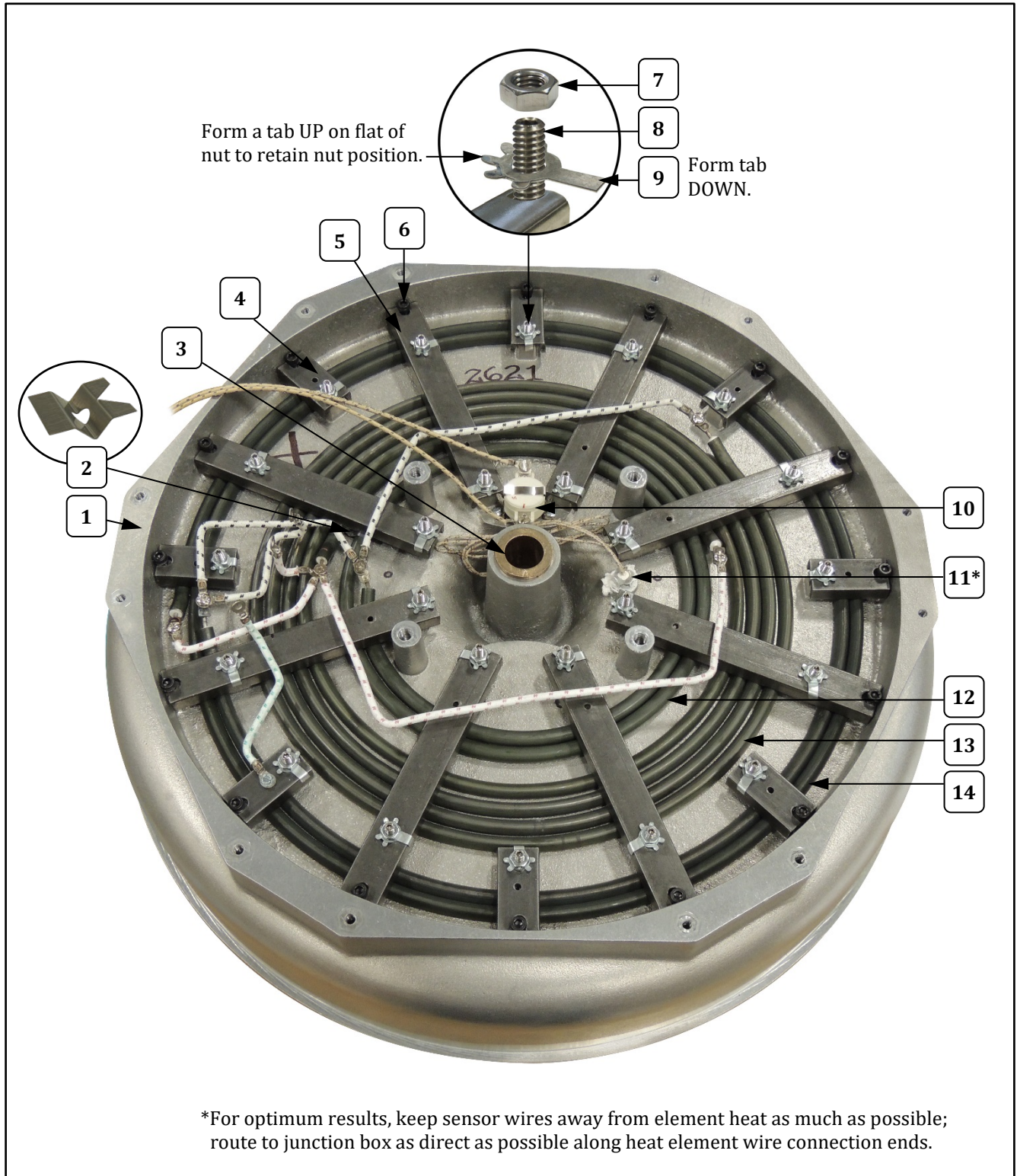



Kettle Element View – Parts List

Item	Part Description	Part Number	
		2620D, 2620DT 2621D, 2621DT	2630D, 2630DT 2631D, 2631DT
1	KETTLE, CORN TREAT CENTER (inclds 2 bushings)	48829	48829
2	ELEMENT SHIM	68787	68787
3	BUSHING, MIX BOWL (2 Required, one used on top and one on bottom)	46484	46484
4	ELEMENT CLAMP – Short (8 required)	48832	48832
5	ELEMENT CLAMP – Long (8 required)	48831	48831
6	1/4-20 X 1/2 SHCS	46722	46722
7	HEX NUT 1/4-20	74133	74133
8	1/4-20 x 1.25 SET SCREW	69140	69140
9	NUT RETAINER	50190	50190
10	THERMOSTAT KETTLE L-510	82219	82219
11*	RTD HEAT SENSOR	46299	46299
12	1800W 230V TUBULAR ELEMENT	48650EX	
	1800W 208V ELEMENT		69863
13	2700W 240V HEAT ELEMENT	46498	
	2700W 208V ELEMENT		69864
14	2100 WATT 240V HEAT ELEMENT	48887	
	2100W 208V ELEMENT		69865

Digital Control Panel (D Models)

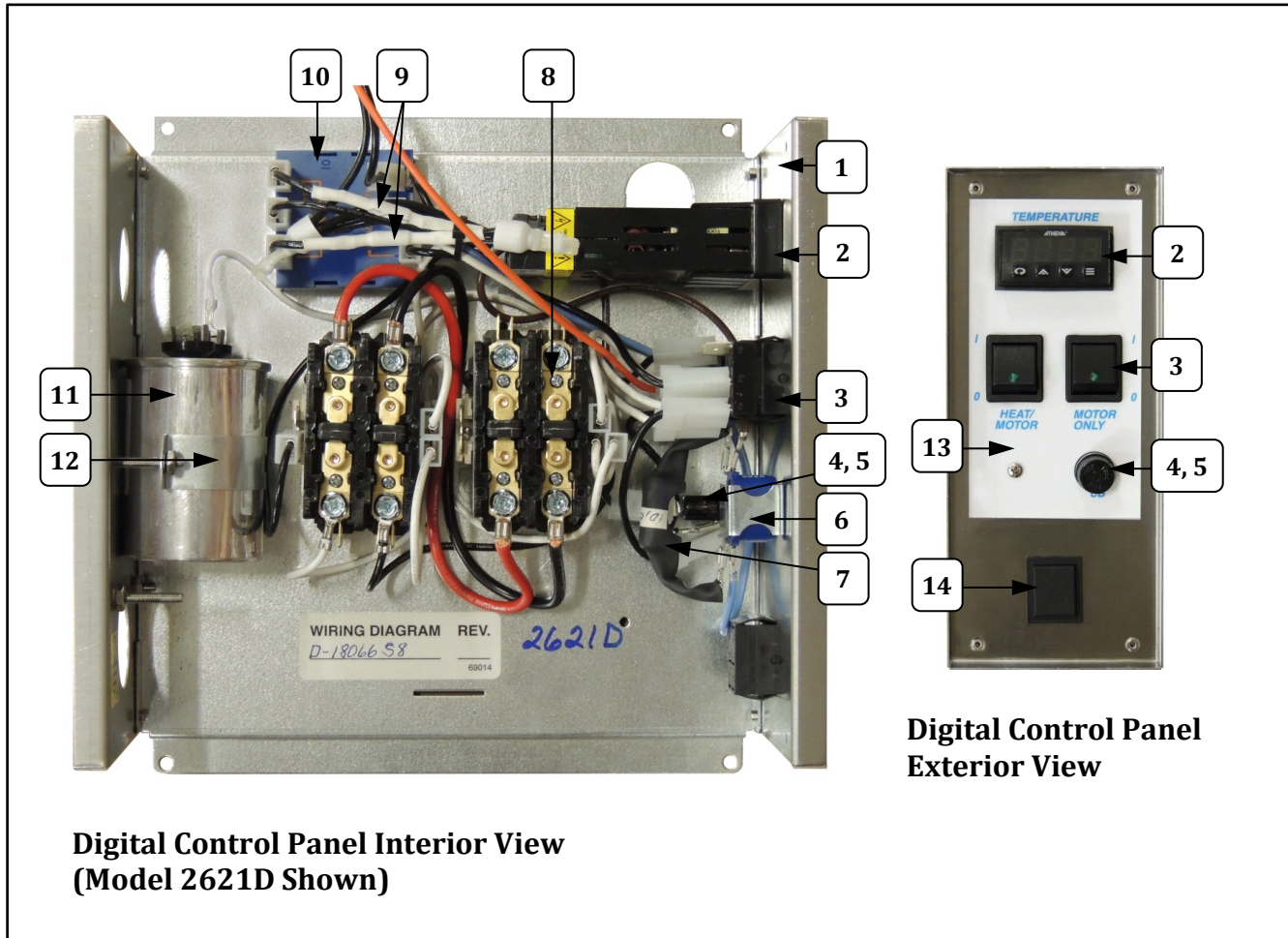

**Digital Control Panel Interior View
(Model 2621D Shown)**

**Digital Control Panel
Exterior View**

Item	Parts Description	Part Number	
		RH Models 2620D, 2630D	LH Models 2621D, 2631D
1	DIGITAL CONTROL BOX ASSY (includes support and cover)	55494	
2	TEMPERATURE CONTROL 32C	48720	48720
3	SWITCH, ROCKER DPDT LGHT	48616	48616
4	FUSE HOLDER	74636	74636
5	FUSE, 15 AMP	55462	55462
6	BUZZER SIGNAL 240 VAC	46120	46120
7	RESISTOR, 10K 8 WATT	48612EX	48612EX
8	CONTACTOR, 2 POLE 40 AMP	62059EX	62059EX
9	RESISTOR, 500K 1 WATT (2 required)	55009	55009
10	TIMER, PERCENTAGE 60 SEC	48688EX	48688EX
11	20 MFD CAPACITOR	55558	55558
12	CAPACITOR STRAP	48301	48301
13	NAMEPLATE	48668	48668
14	HOLE PLUG, ROCKER SWITCH	42743	42743

Dual Timer Digital Control Panel (DT Models)

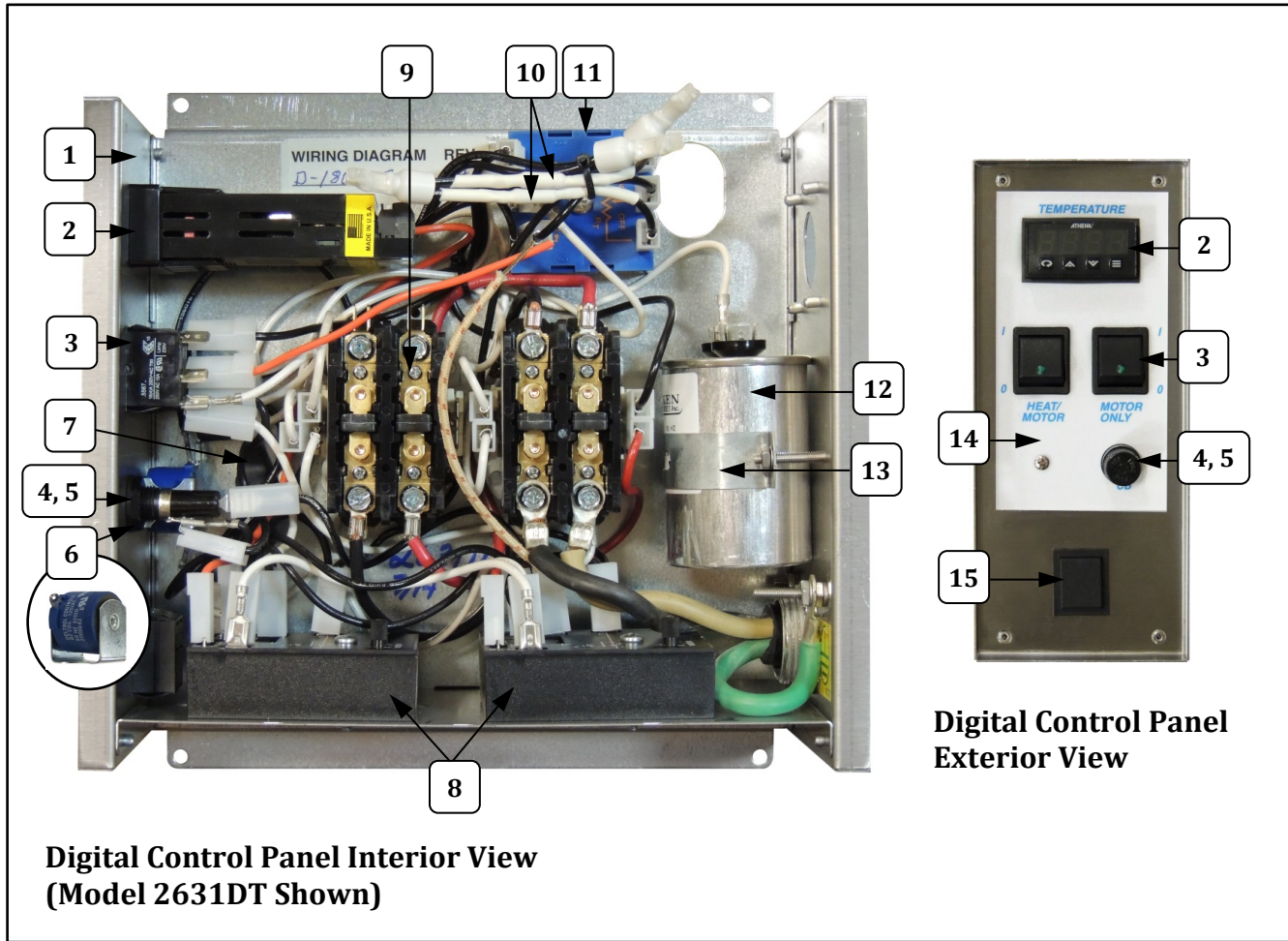

**Digital Control Panel Interior View
(Model 2631DT Shown)**

**Digital Control Panel
Exterior View**

Item	Parts Description	Part Number	
		RH Models 2620DT, 2630DT	LH Models 2621DT, 2631DT
1	DIGITAL CONTROL BOX ASSY (includes support and cover)	55494	
2	TEMPERATURE CONTROL 32C	48720	48720
3	SWITCH, ROCKER DPDT LGHT	48616	48616
4	FUSE HOLDER	74636	74636
5	FUSE, 15 AMP	55462	55462
6	BUZZER SIGNAL 240 VAC	46120	46120
7	RESISTOR, 10K 8 WATT	48612EX	48612EX
8	TIMER, ONE SHOT OFF TRIG (2 required)	55464EX	55464EX
9	CONTACTOR, 2 POLE 40 AMP	62059EX	62059EX
10	RESISTOR, 500K 1 WATT (2 required)	55009	55009
11	TIMER, PERCENTAGE 60 SEC	48688EX	48688EX
12	20 MFD CAPACITOR	55558	55558
13	CAPACITOR STRAP	48301	48301
14	NAMEPLATE	48668	48668
15	HOLE PLUG, ROCKER SWITCH	42743	42743

Safety Labels

Unit Labels

Power Cord Label

Item	Part Description	Part Number
		All Models
1	COOKER LABEL	111031
2	MINIMUM CLEARANCE LABEL	88720
3	SET POINT LABEL	55474
4	MAIN GROUND LABEL	42375
5	WARNING LABEL CORD	68720

Accessories

Item	Part Description	Part Number
		All Models
1	8 CUP MEASURE	69826
2	2 CUP ACRYLIC MEASURE	62807
3	36IN SS MIXING PADDLE	121061
4	STAMPED ALUM SCOOP	2071
5	CORN MEASURE (20 Gallon)	48886
6	RECEPTACLE 6-50R 50A 250V	89830



WARRANTY

Gold Medal Products Co. warrants to the original purchaser each item of its manufacture to be free of defects in workmanship and material under normal use and service. Gold Medal Products Co.'s obligation under this warranty is limited solely to repairing or replacing parts, f.o.b. Cincinnati, Ohio, which in its judgment are defective in workmanship or material and which are returned, freight prepaid, to its Cincinnati, Ohio factory or other designated point. Except for "Perishable Parts" on specific machines, the above warranty applies for a period of two (2) years from the date of original sale to the original purchaser of equipment when recommended operating instructions and maintenance procedures have been followed. These are packed with the machine. Parts warranty is two (2) years, labor is six (6) months.

THIS WARRANTY IS IN LIEU OF ALL OTHER WARRANTIES EXPRESSED OR IMPLIED, AND OF ALL OTHER OBLIGATIONS OR LIABILITIES ON OUR PART, INCLUDING THE IMPLIED WARRANTY OF MERCHANTABILITY. THERE ARE NO WARRANTIES WHICH EXTEND BEYOND THE DESCRIPTION ON THE FACE HEREOF. In no event shall Gold Medal Products Co. be liable for special, incidental or consequential damages. No claim under this warranty will be honored if the equipment covered has been misused, neglected, damaged in transit, or has been tampered with or changed in any way. No claim under this warranty shall be honored in the event that components in the unit at the time of the claim were not supplied or approved by Gold Medal Products Co. This warranty is effective only when electrical items have been properly attached to city utility lines only at proper voltages. This warranty is not transferable without the written consent of Gold Medal Products Co.

The term "Original Purchaser" as used in this warranty shall be deemed to mean that person, firm, association, or corporation who was billed by the GOLD MEDAL PRODUCTS CO., or their authorized distributor for the equipment.

THIS WARRANTY HAS NO EFFECT AND IS VOID UNLESS THE ORIGINAL PURCHASER FIRST CALLS GOLD MEDAL PRODUCTS CO. AT 1-800-543-0862 TO DISCUSS WITH OUR SERVICE REPRESENTATIVE THE EQUIPMENT PROBLEM, AND, IF NECESSARY, FOR INSTRUCTIONS CONCERNING THE REPAIR OR REPLACEMENT OF PARTS.

NOTE: This equipment is manufactured and sold for commercial use only.



GOLD MEDAL PRODUCTS CO.

10700 Medallion Drive, Cincinnati, Ohio 45241-4807 USA

gmpopcorn.com

Phone: (800) 543-0862 Fax: (800) 542-1496
(513) 769-7676 (513) 769-8500