



# Instruction Manual

## Spartan



Model No. 2671







**GOLD MEDAL® PRODUCTS CO.**



10700 Medallion Drive, Cincinnati, Ohio 45241-4807 USA



# SAFETY PRECAUTIONS

	 <b>DANGER</b>
	<p>Machine must be properly grounded to prevent electrical shock to personnel. Failure to do so could result in serious injury, or death.  <b>DO NOT</b> immerse any part of this equipment in water.  <b>DO NOT</b> use excessive water when cleaning.            Keep cord and plug off the ground and away from moisture.            Always unplug the equipment before cleaning or servicing.            Make sure all machine switches are in the OFF position before plugging the equipment into the receptacle.</p> <p style="text-align: right; font-size: small;">008_051514</p>

	 <b>DANGER</b>
	<p>Improper installation, adjustment, alteration, service, or maintenance can cause property damage, injury, or death. Any alterations to this equipment will void the warranty and may cause a dangerous condition. This appliance is not intended to be operated by means of an external timer or separate remote-control system. <b>NEVER</b> make alterations to this equipment. Read the Installation, Operating, and Maintenance Instructions thoroughly before installing, servicing, or operating this equipment.</p> <p style="text-align: right; font-size: small;">014_020416</p>

	 <b>WARNING</b>
	<p>To avoid burns, <b>DO NOT</b> touch the kettle or any heated surface.  <b>DO NOT</b> place or leave objects in contact with heated surfaces.</p> <p style="text-align: right; font-size: small;">013_092414</p>

	 <b>WARNING</b>
	<p><b>ALWAYS</b> wear safety glasses when servicing this equipment.</p> <p style="text-align: right; font-size: small;">010_010914</p>

	 <b>WARNING</b>
	<p>No user serviceable parts inside. Refer servicing to qualified service personnel.</p> <p style="text-align: right; font-size: small;">011_051514</p>

	 <b>WARNING</b>
	<p>Read and understand operator's manual and all other safety instructions before using this equipment. To order copies of the operator's manual go to <a href="http://gmpopcorn.com">gmpopcorn.com</a> or write to Gold Medal Products Co., 10700 Medallion Drive, Cincinnati, OH 45241 USA 1-(800)-543-0862</p> <p style="text-align: right; font-size: small;">022_060215</p>



## SAFETY PRECAUTIONS (continued)

	<b>⚠ WARNING</b>
	<p>DO NOT allow direct contact of this equipment by the public when used in food service locations. Only personnel trained and experienced in the equipment operation may operate this equipment. Carefully read all instructions before operation.</p> <p style="text-align: right;">012_010914</p>

	<b>⚠ WARNING</b>
	<p>This machine is NOT to be operated by minors.</p> <p style="text-align: right;">007_010914</p>

This appliance is not intended for use by persons (including children) with reduced physical, sensory or mental capabilities, or lack of experience and knowledge, unless they have been given supervision or instruction concerning use of the appliance by a person responsible for their safety.

**Note:** Improvements are always being made to Gold Medal’s equipment. This information may not be the latest available for your purposes. It is critical that you call Gold Medal’s Technical Service Department at 1-800-543-0862 for any questions about your machine operations, replacement parts, or any service questions. (Gold Medal Products Co. does not assume any liability for injury due to careless handling and/or reckless operation of this equipment.)



# INSTALLATION INSTRUCTIONS

## Inspection of Shipment

After unpacking, check thoroughly for any damage which may have occurred in transit. Claims should be filed immediately with the transportation company. The warranty does not cover damage that occurs in transit, or damage caused by abuse, or consequential damage due to the operation of this machine, since it is beyond our control (reference warranty in back of manual).

## Manual

Read and understand the operator's manual and all other safety instructions before using this equipment. To order copies of the operator's manual go to [gmpopcorn.com](http://gmpopcorn.com) or write to Gold Medal Products Co., 10700 Medallion Drive, Cincinnati, OH 45241 USA 1-(800)-543-0862.

## Setup

Your new *Spartan* is completely assembled and tested at the factory. Remove all packing material and tape before starting operation.



## Electrical Requirements

**DOMESTIC UNITS:** 120/208 V~ or 120/240 V~, 7177 W, 60 Hz

Domestic units are designed to operate on single phase, 50 AMP, 4 wire supply, 120/208 or 120/240 V~ (2 Hot, 1 Neutral, 1 Ground). All electrical components in this machine are 120 V (motors, heat elements, lights, etc.) and therefore require "Hot to Neutral" connection (**NOT** "Hot to Hot"). A 50 AMP wall receptacle (NEMA 14-50) is supplied with the machine. The receptacle will accept the attachment plug on the machine and must be used. Reference the Receptacle Installation instructions for wiring the NEMA 14-50 Receptacle.

**EXPORT UNITS:** 230 V~, 7177 W, 50 Hz

Export units are designed to operate on single phase, 16 AMP, 4 wire supply, 230 V~ (2 Hot, 1 Neutral, 1 Ground). All electrical components in this machine are 230 V (motors, heat elements, lights, etc.) and therefore require "Hot to Neutral" connection (**NOT** "Hot to Hot"). A certified electrician must supply and install the wall receptacle for this unit; reference the Receptacle Wiring Diagram for Export Units.

	 <b>DANGER</b>
	<p>Machine must be properly grounded to prevent electrical shock to personnel. Failure to do so could result in serious injury, or death. DO NOT immerse any part of this equipment in water. DO NOT use excessive water when cleaning. Keep cord and plug off the ground and away from moisture. Always unplug the equipment before cleaning or servicing. Make sure all machine switches are in the OFF position before plugging the equipment into the receptacle.</p> <p>008_051514</p>

A certified electrician must furnish sufficient power for proper machine operation and install any supplied receptacle. We recommend this equipment be on a dedicated and protected circuit. Failure to wire properly will void the warranty and may result in damage to the machine. It is Gold Medal Products Co.'s recommendation that this machine be plugged directly into a wall outlet. The use of extension cords is not recommended due to safety concerns, and may cause sacrificed and/or reduced performance. Make sure cord is located to prevent a trip hazard or unit upset.

### Receptacle Wiring Diagram for NEMA 14-50 (for Domestic Units)

A certified electrician must follow the IMPORTANT instructions below for installation of the NEMA 14-50 Receptacle (Gold Medal Item No. [82920](#)) provided with the unit. If the receptacle is wired incorrectly, the heat elements/kettle and other electrical components could be at 208 or 240 V potential instead of the needed 120 V, resulting in excessive temperatures in the heat elements (i.e.: kettle) and possible fire, and/or damage to electrical components.

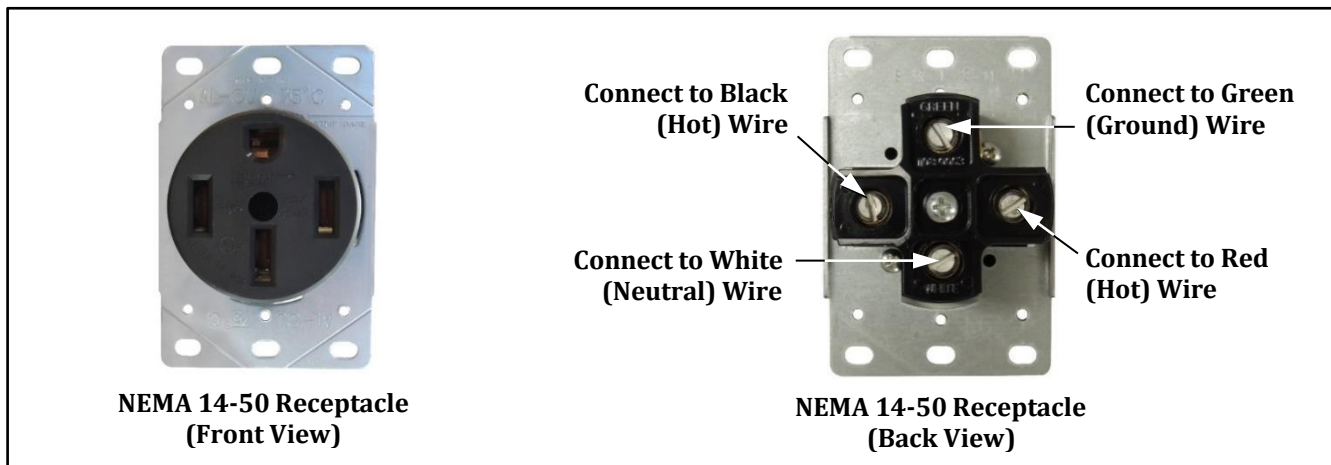

### Receptacle Wiring Diagram (for Export Units)

A certified electrician must supply and install the required wall receptacle for this unit, follow the IMPORTANT instructions shown. This unit is designed to operate on single phase, 16 AMP, 4 wire supply. All electrical components in this machine are 230 V. If the receptacle is wired incorrectly, the heat elements/kettle and other electrical components could be at 400 V potential instead of the needed 230 V, resulting in excessive temperatures in the heat elements (i.e.: kettle) and possible fire, and/or damage to electrical components.

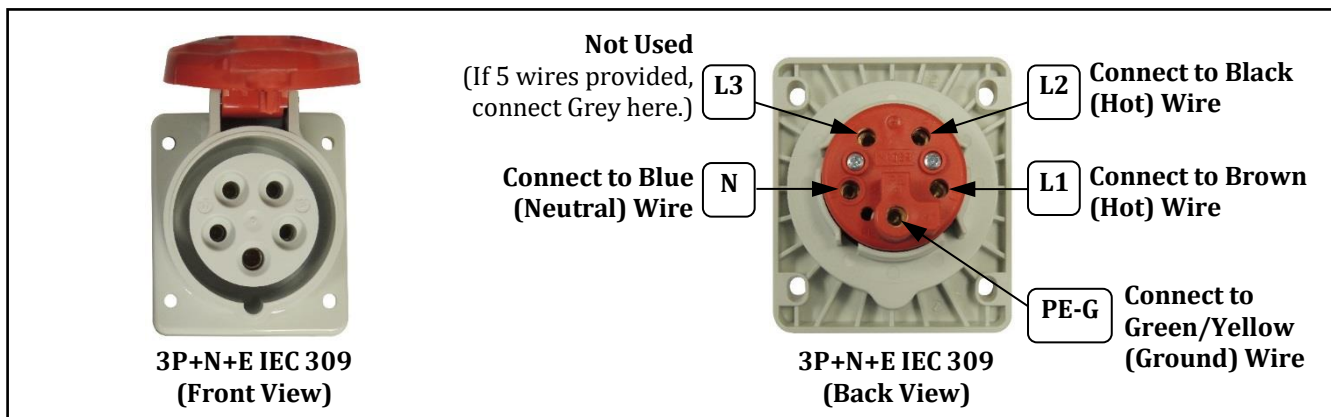

## Before You Plug In Machine

1. Make sure all machine switches are OFF before plugging equipment into receptacle.
2. Make sure wall outlet can accept the grounded plugs (where applicable) on the power supply cord.
3. The wall outlet must have the proper polarity. If in doubt, have a competent electrician inspect the outlet and correct if necessary.
4. **DO NOT** use a grounded to un-grounded receptacle adapter (where applicable).
5. Install unit in a level position.

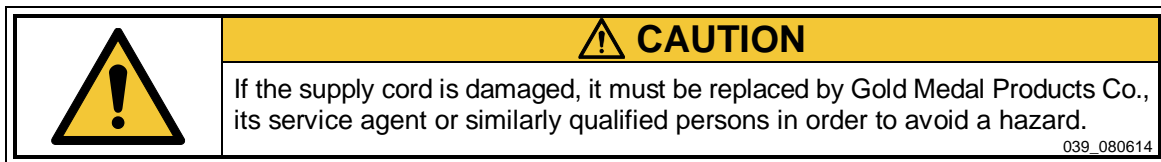

## Oil Dispense Installation



To connect and calibrate the oil dispense system to this popper; refer to the Bucket Pump (Gold Medal Item No. 2114 Series) or Bag-in-a-Box (Gold Medal Item No. 2257 Series) Instruction Manual included with the unit.



---

# OPERATING INSTRUCTIONS

## Controls and Their Functions

### LIGHT SWITCH

This operates all of the lights, interior and dome, on your popcorn machine.

### POPCORN CONDITIONER SWITCH

Operates the blower in the corn storage area, keeps popcorn fresh and crisp.

### KETTLE HEAT SWITCH

This operates the heating elements in the popping kettle.

### KETTLE MOTOR AND EXHAUST SWITCH

Two position (ON/OFF), lighted rocker switch which operates the kettle agitator motor, and the exhaust fan. The Kettle Motor Switch **MUST** be ON at all times when there is popcorn (popped or un-popped) in the kettle.

### OIL SYSTEM AND MASTER SWITCH

Two position, ON/OFF lighted rocker switch - supplies power to the oil pump (either the Bag-in-a-Box or Bucket Pump model). Reference the Instruction Manual for the oil dispense unit.

**Bag-in-a-Box Model:** Oil System Master Switch ON, provides power to the oil dispense unit, activates the warmer/blower, and the heated line kit (if equipped).

**Note:** Coconut oil will congeal at temperatures below approximately 76°F (24°C). For machines used daily, leave the Oil System Master Switch on at all times and keep the cabinet doors closed to prevent the oil from becoming solid. If the machine has not been used for several days, turn the Oil System Master Switch ON the night before it is expected to be used.

**Bucket Pump Model:** Oil System Master Switch ON, activates the 30 watt heating element on the bucket pump to keep the coconut oil liquid.

### “RED” OIL DISPENSES PUSH BUTTON SWITCH

When pushed, this will dispense the predetermined amount of oil into the kettle. (Reference the Instruction Manual for the oil dispense unit to program the oil dispense volume.)

### SALT/SWEET SWITCH (if equipped)

This adjusts the kettle temperature for salt or sugar based popcorn.

### LIGHT & AUDIBLE SOUND (LOAD DUMP)

Yellow indicator light and audible sound (if engaged), used to signal Load Dump. Therefore, if the yellow light is ON, and the buzzer is sounding, **one** of the following actions should be taken:

- Load the corn and oil **or**
- Dump the popped corn from the kettle **or**
- Turn OFF the Kettle Heat Switch if you are finished popping corn.



**FLEXI-POP SWITCH (if equipped)**

This changes energy to the kettle for the load switch from 52 oz. to 32 oz. it will automatically adjust the oil amount on the 2257D model of oil pump. The blue light and blue labeled cup are for the 32oz and the green are for the 52oz. (Reference Instruction Manual for the oil dispense unit.)

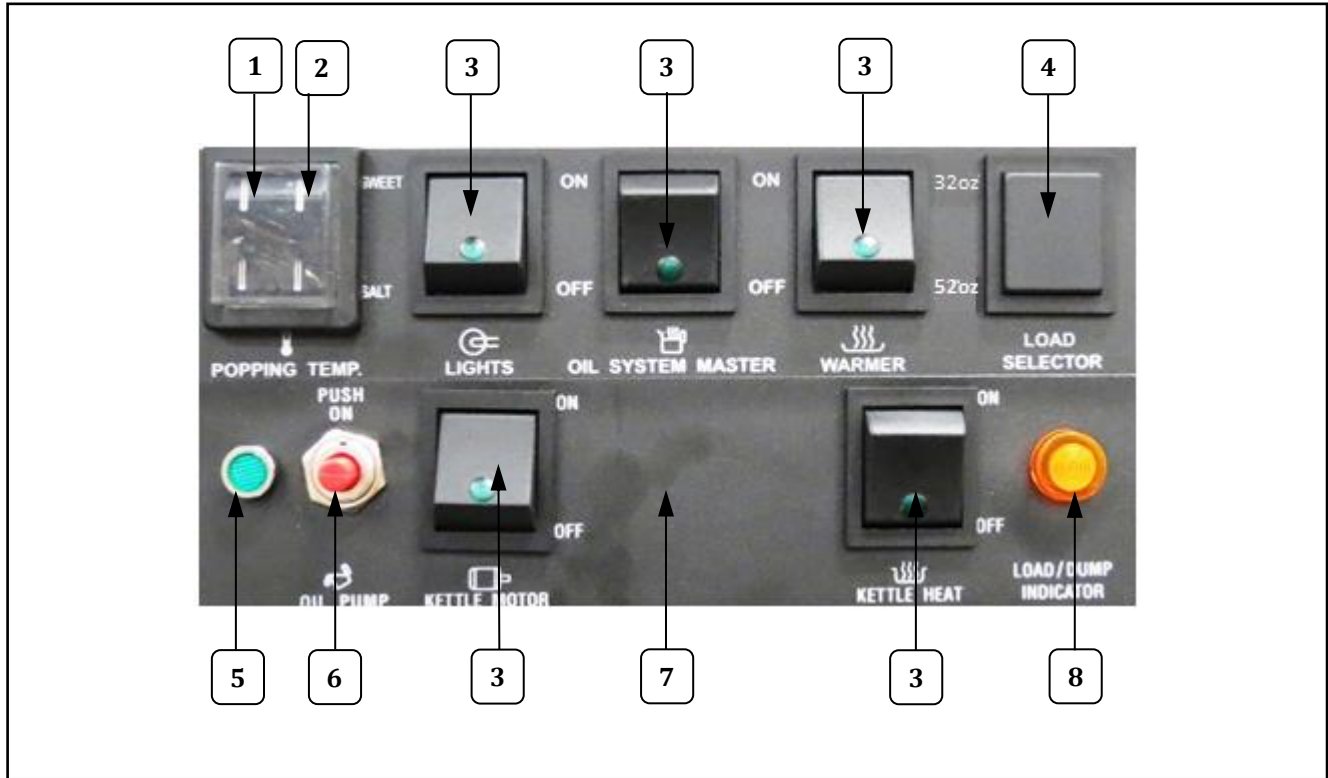

Item	Part No.	Part Description
1	55440	DPDT ROCKER SWITCH
2	48786	SWITCH COVER
3	42798	LIGHTED ROCKER
4	39410	ROCKER SWITCH (not shown) FLEXI-POP ONLY
5	48660	DOMESTIC GREEN PILOT LIGHT 125V
	48660EX	EXPORT GREEN PILOT LIGHT 230V
6	41031	SWITCH OIL PUMP
7	63429	CONTROL BOX COVER
8	55039	DOMESTIC AMBER PILOT LIGHT 125V
	55039EX	EXPORT AMBER PILOT LIGHT 230V



# Popping Corn Instructions

This section describes popping instructions for Standard (salted) popcorn and Sweet popcorn (if equipped with Salt-Sweet option). Flexi-Pop option (if equipped) pops a full size or reduced size batch of popcorn.

## Remember (for all popping modes):

When the Load Dump Light comes ON, and Audible Signal (if enabled) is sounding, **one** of the following actions should be taken:

- Load the corn and oil **or**
- Dump the popped corn from the kettle **or**
- Turn OFF the Kettle Heat if you are finished popping corn.

## Amount of Popcorn and Oil – Salted Popcorn

This popper is equipped with corn, salt, and oil measures. Gold Medal recommends flavored and colored coconut oil. Popcorn popped in coconut oil stays fresh longer and does not leave black deposits in the kettle like other oils. Use only top quality, fresh popcorn from reputable suppliers.

Kettle Size	Popcorn Charge	Oil Charge	Flavacol (Salt)
52 oz.	52 oz. (1.5 L)	17 oz. (503 ml)	4 Tblsp. (59cc)
32 oz. (Flexi-Pop)	32 oz. (946 ml)	10.5 oz. (311 ml)	2 Tblsp. (29.6cc)

**Note:** When popping with coconut oil, be sure the oil is liquid. As a check, dispense oil into a measuring cup first, then use that oil for the first popping cycle.

1. Turn all switches ON; set Flexi-Pop Switch (if equipped) to desired batch size; set Salt-Sweet Switch (if equipped) to Salt mode.
2. When kettle is ready (about 5-8 minutes), the Load/Dump Light and Audible Signal (if enabled) will turn ON.
3. Lift kettle lid and pour in pre-measured amount of corn and Flavacol (see chart for amounts); close lid.
4. Press the “Red” Oil Dispense PB Switch to add oil (the Load/Dump Light and Signal will turn OFF in approx. 20 seconds).
5. When corn has finished popping, the Load/Dump Light and Audible Signal will turn ON, then gently dump the popcorn.

**Note:** The signal “To Dump” was factory set based on Gold Medal popcorn and oil. If, after 3 consecutive batches, the signal occurs before or after popping has stopped, then the signal timing can be adjusted. Have a qualified service person adjust the signal to dump (reference Electronic Temperature Control section of the Parts Manual for the unit).

6. On final kettle of corn, turn Kettle Heat Switch OFF just as lids are forced open by the popping corn. This procedure saves electricity, since kettle has plenty of heat, and helps eliminate smoke/odor from any oil residue that remains after popping has stopped.

**Note:** When Kettle Heat Switch is OFF, machine will not beep on the last batch.

7. When finished popping, turn KETTLE HEAT and KETTLE MOTOR switches OFF.

**NEVER LEAVE THE HEAT ON WHEN YOU ARE NOT POPPING CORN!**



## Popping Sweet Popcorn (if equipped)

Gold Medal recommends white coconut oil for popping Glaze Pop (colored oil can change the popcorn color). Glaze Pop cooks directly in the kettle. **DO NOT** use popcorn seasoning salt when popping Glaze Pop.

Kettle Size	Popcorn Charge	Oil Charge	Glaze Pop/Sugar
52 oz.	52 oz. (1.5 L)	17 oz. (503 ml)	26 oz. (769 ml)
32 oz. (Flexi-Pop)	32 oz. (946 ml)	10.5 oz. (311 ml)	16 oz. (473 ml)

**Note:** When popping with coconut oil, be sure oil is liquid. As a check, dispense oil into a measuring cup first then use that oil for the first popping cycle.

1. Turn all switches ON; set Flexi-Pop Switch (if equipped) to desired batch size; set Salt-Sweet Switch to Sweet mode.
2. When kettle is ready (about 5-8 minutes), the Load/Dump Light and Audible Signal (if enabled) will turn ON.
3. Lift kettle lid and pour in pre-measured amount of corn.
4. Press the "Red" Oil Dispense PB Switch to add oil (the Load/Dump Light and Signal will turn OFF in approx. 20 seconds).
5. Add pre-measured amount of Glaze Pop or Sugar (when using sugar, we recommend using Compound "S" to help keep kettle clean); close lid.
6. When corn has finished popping, the Load/Dump Light and Audible Signal will turn ON, then gently dump the popcorn.

**Note:** The signal "To Dump" was factory set based on Gold Medal popcorn and oil. If, after 3 consecutive batches, the signal occurs before or after popping has stopped, then the signal timing can be adjusted. Have a qualified service person adjust the signal to dump (reference Electronic Temperature Control section of the Parts Manual for the unit).

7. On final kettle of corn, turn Kettle Heat Switch OFF just as lids are forced open by the popping corn. This procedure saves electricity, since kettle has plenty of heat, and helps eliminate smoke/odor from any oil residue that remains after popping has stopped.



**Note:** When Kettle Heat Switch is OFF, machine will not beep on the last batch.

8. When finished popping, turn KETTLE HEAT and KETTLE MOTOR switches OFF.

**NEVER LEAVE THE HEAT ON WHEN YOU ARE NOT POPPING CORN!**

9. Clean kettle when finished popping Glaze Pop or sugar corn, and prior to switching to popping salted popcorn.

# CLEANING INSTRUCTIONS

	 <b>DANGER</b>
	<p>Machine must be properly grounded to prevent electrical shock to personnel.  <b>DO NOT immerse in water.</b>            Always unplug the equipment before cleaning or servicing.</p> <p style="text-align: right; font-size: small;">025_020314</p>

	 <b>WARNING</b>
	<p>To avoid serious burns, DO NOT touch the kettle while it is hot!</p> <p style="text-align: right; font-size: small;">028_082715</p>

Good sanitation practice demands that all food preparation equipment be cleaned regularly (only use non-toxic, food grade cleaners). A clean looking, well-kept machine is one of the best ways of advertising your product.

**Note:** It is extremely important to follow all cleaning procedures, otherwise parts damage and equipment failure will result. The warranty does not cover parts that are damaged due to improper cleaning.

## Daily Kettle Cleaning Instructions

**Under no circumstances should the kettle be removed from the machine for cleaning.**

**CAUTION:** A hot kettle will cause burns if you touch it with your hand. Allow kettle to cool at least 1 hour before attempting to clean. **DO NOT** use ice or water to cool down a hot kettle! Severe kettle damage will result!

1. When cool, wipe **outside** of kettle with a clean, soft cloth. **DO NOT** use oven cleaners or abrasive materials as they will damage the kettle.
2. Every night, mix Gold Medal's Heat'n Kleen solution (Item No. 2095), 2 tablespoons per gallon of water. It is not necessary to use the entire gallon at once; only use enough to fill the kettle 1/2 inch deep.
3. Turn kettle heat ON. When water starts to boil, turn kettle heat OFF.
4. Allow to cool at least 1 hour, then dump solution into a bucket and wipe inside of kettle with a clean cloth. Make sure all solution goes into the bucket; do not spill any in the interior of machine.

For an extra dirty kettle, the process may be repeated; or, after turning kettle heat OFF, allow solution to sit in kettle overnight. The next morning, dump solution into a bucket and wipe inside of kettle with a clean cloth.

5. A Clean-In-Place Hook is located behind the kettle support arm (on operator side). This feature safely holds the kettle in place for cleaning purposes, and allows access to hard to reach places without removing the kettle. With the lid and agitator assembly removed, tilt kettle into the dump position, and swing the hook into position (see image below).
6. With unit OFF and unplugged, wipe kettle lead cord with a clean SLIGHTLY damp cloth. **DO NOT get moisture into the kettle lead-in cord, severe damage will result.**

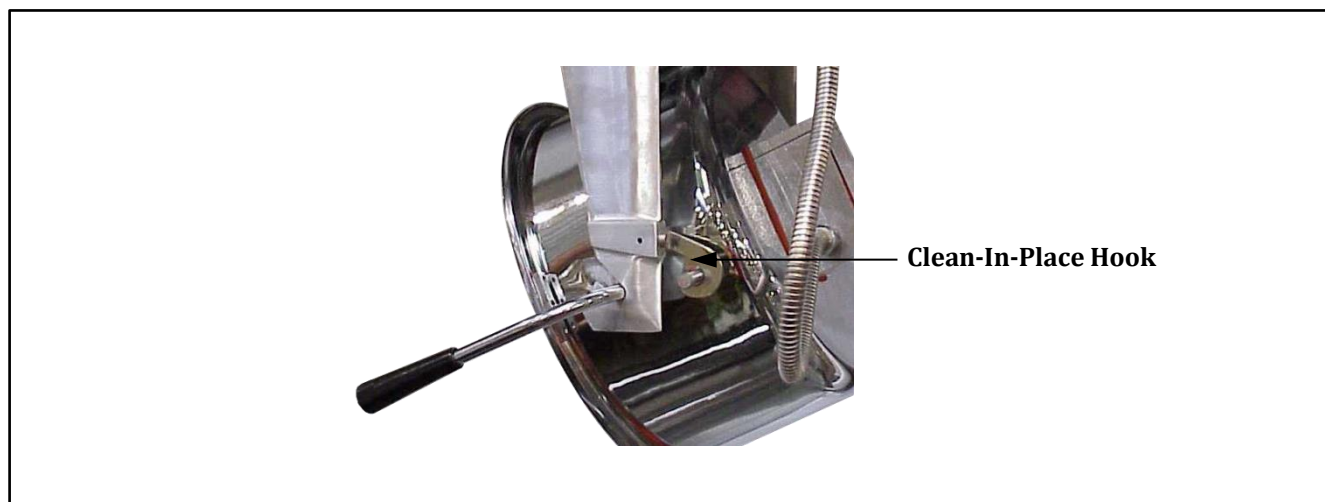

## Daily Unit Cleaning Instructions

1. Turn machine OFF, unplug unit and allow it to cool before attempting to clean.
2. Clean all pans/accessories in order to sanitize them before each use.
3. Clean under corn pan to remove all popcorn bits and seeds.
4. Take a clean, SLIGHTLY damp cloth and wipe excess grease from glass and cabinet.
5. Wipe stainless steel parts with a clean cloth and cleaner designed for stainless steel, such as Gold Medal Watchdog Stainless Cleaner (Item No. 2088).  
**DO NOT** use oven cleaners or abrasive materials as they will damage parts of machine.
6. Clean glass panels with glass cleaner. Gold Medal Watchdog Glass Cleaner (Item No. 2588) is recommended.  
Ammonia cleaners will damage plastic doors/panels. Use only non-ammonia cleaners, such as Gold Medal Watchdog Glass Cleaner (Item No. 2588).

## Daily Sanitizing the Internal Parts (Tubing, Pump, Etc.)

For Models with an oil dispenser, Gold Medal Products Co. recommends pumping sanitizer through the system nightly to clean pumps and topping lines.

## Filter Cleaning

The popper is equipped with an efficient and durable filtration system. The first mesh filter should be cleaned on a daily basis, and the two internal filters should be cleaned weekly to maintain maximum efficiency. **Follow the steps below for proper filter cleaning:**

### Step 1: Daily Filter Cleaning

**Turn unit OFF and allow it to cool before removing any filters.**

Remove the first Mesh Filter, and clean it each day after use. This filter can be removed without taking off the filter cover. See Step 3 for instructions on cleaning the Mesh Filter.

### Step 2: Weekly Filter Cleaning

Loosen the 2 screws on the filter cover plate, on the ceiling inside the popper. Remove the cover, the Bag Filter, and the 2 Mesh Filters.

**Step 3:** Clean the bag filter and mesh filters in warm soapy water, then rinse. Let dry overnight, then reinstall.

**CAUTION:** It is important to keep the filters clean, to let the exhaust system do its job.

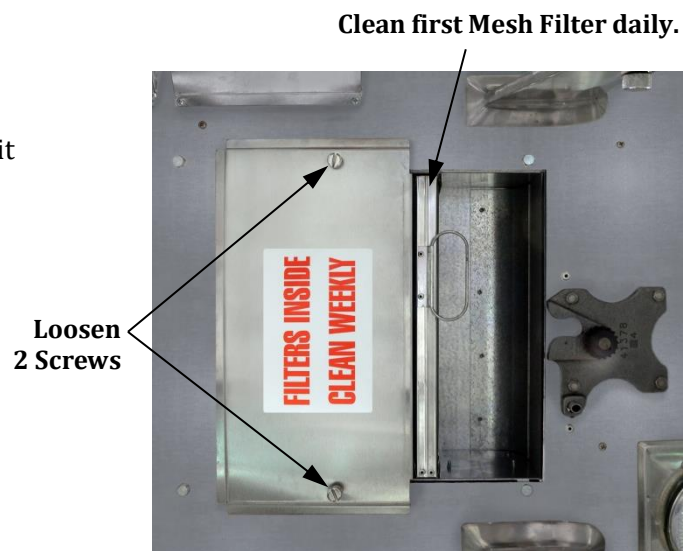

Oil Mist Bag Filter



(2) Metal Mesh Filters



---

## Weekly Clean the Crisper/Blower Filters

Follow the directions below each week to clean the crisper/blower filters.

1. Turn machine OFF, unplug unit and allow it to cool before attempting to clean.
2. Lift off the corn pan to view the blower assembly.
3. Remove each filter guard (if applicable) then lift filters out and clean using warm soapy water (or replace if needed). Rinse thoroughly and allow to dry, before reinstalling.

## Clean the Crisper/Blower Compartment

The blower compartment **MUST** be inspected/cleaned every 3-4 months by Qualified Service Personnel to maintain proper operation.

1. Turn machine OFF, unplug unit and allow it to cool before attempting to clean.
2. Lift off the corn pan to view the blower assembly.
3. Remove the blower cover and if required, carefully clean the blower compartment, and underneath the element with a vacuum only.
4. After cleaning, reassemble blower cover and corn pan.



## Troubleshooting

Issue	Possible Cause	Solution
<b>Power to the Unit</b>	A. Power to the Unit B. Mini Circuit Breaker(s) on popper tripped (if equipped)	A. Make sure the unit's power cord is plugged in. B. Mini Circuit Breaker(s) supplies power to all unit features. If equipped, Mini Circuit Breaker(s), will be located on the control panel or ceiling of the popper. If breaker(s) is reset, then trips again, the unit must be inspected/repared before going any further.
<b>Kettle Does Not Heat</b>	A. Power to the Kettle (for units with a removable kettle)  B. Kettle Heat Switch  C. Kettle Circuit Breaker          D. Temperature Control Board          E. Heating Element	A. Make sure kettle lead-in cord is plugged in completely and twisted to lock it into the kettle receptacle. (Kettle leads which have a locking ring, ensure locking ring is fully screwed onto kettle receptacle.)  B. Have a qualified service person check the voltage to and from the Kettle Heat Switch; if switch is defective, replace it.  C. If unit is plugged in, and the Kettle Heat Switch is ON, but the small green indicator switch light is OFF, then the Kettle Circuit Breaker may be tripped.  <b>Note:</b> If there is not a separate Kettle Heat Switch on units with the Flexi-Pop option, the Kettle Heat Switch will NOT have an indicator light. In this case the small green light on the Kettle Stir Motor Switch is used to indicate that the Kettle Circuit Breaker is tripped.  Have a qualified service person check if the breaker has tripped (breaker is located under the dome). The Kettle Circuit Breaker may trip during transit; if reset then trips again, the unit must be inspected/ repaired before going any further.  D. A defective thermocouple lead will cause the kettle not to heat. A loose kettle lead-in connection can cause a thermocouple lead issue (indicated by the yellow dump light staying on or blinking, outside of normal operation). ( <b>Units with a removable kettle</b> , make sure kettle lead is plugged in completely and the locking ring is fully screwed onto kettle receptacle.)  Check for control error condition and have a qualified service person check for good connections from the kettle to the control (reference the Electronic Temperature Control section of this manual for light indicators or error conditions.)  E. Heating element in the kettle may be burned out. Check with a qualified service person for inspection/repair.





Issue	Possible Cause	Solution
<b>Oil Pump Does Not Deliver Oil to Kettle</b> (for units equipped with oil)	A. Mini Circuit Breaker(s) on popper tripped  B. Oil Dispense Unit	A. Check the Mini Circuit Breaker(s); if reset, then trips again, the unit must be inspected/ repaired by qualified service personnel.  B. For additional possible causes/solutions, reference the Troubleshooting section of the Oil Dispense Unit Manual.
<b>Long Popping Cycles</b> (Longer than 4 minutes for Salt Popcorn; longer than 6 minutes for Sweet Popcorn)	A. Heating Element  B. Low Voltage  C. Inadequate Supply Lines  D. Inferior Corn	A. One of the heating elements in the kettle may be burned out. This would result in the kettle never reaching the proper operating temperature. Check with a qualified service person for inspection/repair. B. If the machine is operated on low voltage, this could cause the kettle not to reach the proper operating temperature. Check with a qualified electrician. C. Inadequately sized electrical supply lines, in addition to being a fire hazard, would also prevent the kettle from reaching the proper operating temperature. Check with a qualified electrician. D. Inferior quality corn would result in longer popping cycles. Use only top quality hybrid popcorn from reputable suppliers. Even then, if you let your corn pick up moisture or dry out, your popping cycles will be slow.
<b>Kettle Agitator Shaft not Rotating</b>	A. Mini Circuit Breaker(s) on popper tripped (if equipped) B. Kettle Motor Switch  C. Kettle Agitator Shaft/Stir Blade not rotating. <b>(Unit must be OFF, unplugged and cool prior to checking or adjusting the agitator assembly.)</b>	A. Check the Mini Circuit Breaker(s); if reset, then trips again, the unit must be inspected/ repaired by qualified service personnel. B. If the kettle agitator shaft is not rotating, <b>DO NOT</b> pop corn. Make sure the Kettle Motor Switch is ON. If the switch is ON, and the shaft is not rotating, the switch or motor may be faulty, contact qualified service personnel for inspection/repair. C. If the kettle agitator shaft is not rotating, <b>DO NOT</b> pop corn. Check the clearance between the kettle bottom and the stir blade; it should be 1/32" (thickness of a dime).
<b>Yellow Dump Light is ON or Blinking - Buzzer is Sounding</b> (outside of normal operation)  Light on steady, but Kettle not heating enough to pop corn.	A. Temperature Control Board has detected an error condition	A. A loose kettle lead-in connection can cause a thermocouple lead issue. <b>(Units with a removable kettle, make sure kettle lead is plugged in completely and the locking ring is fully screwed onto kettle receptacle.)</b>  Contact qualified service personnel for inspection/repair (reference the Electronic Temperature Control section of this manual for light indicators or error condition.)







<b>Issue</b>	<b>Possible Cause</b>	<b>Solution</b>
<b>Poor Blower Performance</b> (Blower is working, but air not circulating properly.)	A. Filters  B. Popcorn chaff build up	A. Clean or replace blower filters as needed (reference Cleaning and Care section).  B. Have Qualified Service Personnel clean any popcorn chaff build up from the blower compartment (reference Cleaning and Care section).





# MAINTENANCE INSTRUCTIONS

	 <b>DANGER</b>
	<p>Machine must be properly grounded to prevent electrical shock to personnel. Failure to do so could result in serious injury, or death.  <b>DO NOT</b> immerse any part of this equipment in water.  <b>DO NOT</b> use excessive water when cleaning.            Keep cord and plug off the ground and away from moisture.            Always unplug the equipment before cleaning or servicing.            Make sure all machine switches are in the OFF position before plugging the equipment into the receptacle.</p> <p style="text-align: right;">008_051514</p>

	 <b>DANGER</b>
	<p>Improper installation, adjustment, alteration, service, or maintenance can cause property damage, injury, or death. Any alterations to this equipment will void the warranty and may cause a dangerous condition. This appliance is not intended to be operated by means of an external timer or separate remote-control system. <b>NEVER</b> make alterations to this equipment. Read the Installation, Operating, and Maintenance Instructions thoroughly before installing, servicing, or operating this equipment.</p> <p style="text-align: right;">014_020416</p>

	 <b>WARNING</b>
	<p>No user serviceable parts inside. Refer servicing to qualified service personnel.</p> <p style="text-align: right;">011_051514</p>

	 <b>CAUTION</b>
	<p>THE FOLLOWING SECTIONS OF THIS MANUAL ARE INTENDED ONLY FOR QUALIFIED SERVICE PERSONNEL WHO ARE FAMILIAR WITH ELECTRICAL EQUIPMENT. THESE ARE NOT INTENDED FOR THE OPERATOR.</p> <p style="text-align: right;">027_010914</p>

# Electronic Temperature Control (Domestic)

## Operation

The temperature control is factory set to stop the power to the kettle when the thermocouple reaches setpoint. This is also the ideal point to dump the popped corn out of the kettle. On the first start-up, this is the ideal time to load the corn and oil. Therefore, if the Kettle Heat Switch is turned ON and the buzzer is sounding, **one** of the following actions should be taken:

- Load the corn and oil **or**
- Dump the popped corn from the kettle **or**
- Turn OFF the Kettle Heat Switch if you are finished popping corn.

## Adjustment of Electronic Control

This unit has an electronic kettle control with 2 thermocouples (TC), one for control and one for limit. There are no mechanical thermostats in this kettle.

There are (4) factory adjustments on the control:

1. Control Setpoint Temperature – This is factory set, **DO NOT adjust**.
2. Signal to Dump – If you want the signal to dump to be a little sooner or later, you can adjust the Kettle Dump potentiometer (see image below). Turn clockwise (CW) to signal sooner, counterclockwise (CCW) to signal later.
3. The patented Overshoot circuit is tuned for the kettle, **DO NOT adjust** this potentiometer.
4. The Audible Signal to Dump has three options; full volume, half volume, no sound (yellow light only). Adjustments are made by jumper positions (see image below). The unit is shipped with full volume.

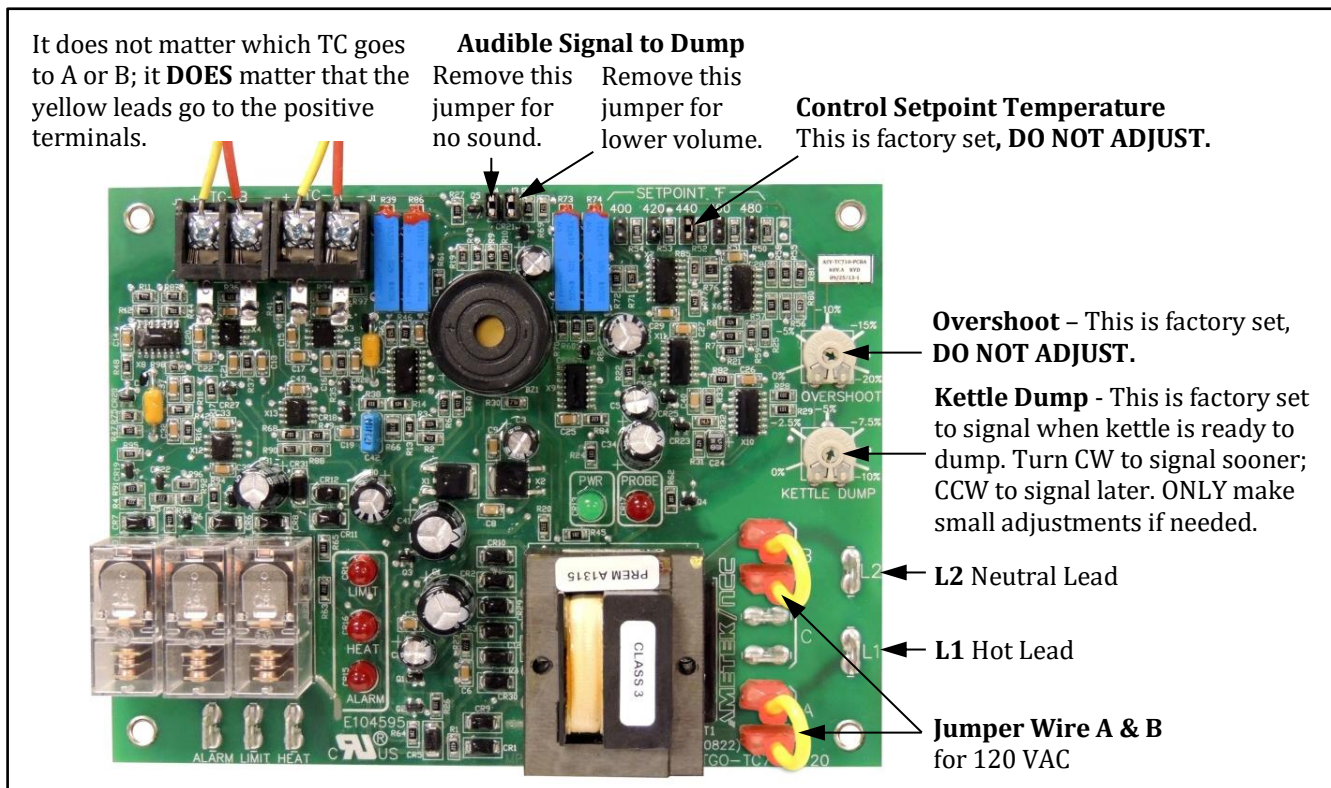

Qualified service personnel only please see Appendix A, Service Bulletin 0074

# Electronic Temperature Control (Export)

## Operation

The temperature control is factory set to stop the power to the kettle when the thermocouple reaches setpoint. This is also the ideal point to dump the popped corn out of the kettle. On the first start-up, this is the ideal time to load the corn and oil. Therefore, if the Kettle Heat Switch is turned ON and the buzzer is sounding, **one** of the following actions should be taken:

- Load the corn and oil **or**
- Dump the popped corn from the kettle **or**
- Turn OFF the Kettle Heat Switch if you are finished popping corn.

## Adjustment of Electronic Control

This unit has an electronic kettle control with 2 thermocouples (TC), one for control and one for limit. There are no mechanical thermostats in this kettle.

There are (4) factory adjustments on the control:

1. Control Setpoint Temperature – This is factory set, **DO NOT adjust**.
2. Signal to Dump – If you want the signal to dump to be a little sooner or later, you can adjust the Kettle Dump potentiometer (see image below). Turn clockwise (CW) to signal sooner, counterclockwise (CCW) to signal later.
3. The patented Overshoot circuit is tuned for the kettle, **DO NOT adjust** this potentiometer.
4. The Audible Signal to Dump has three options; full volume, half volume, no sound (yellow light only). Adjustments are made by jumper positions (see image below). The unit is shipped with full volume.

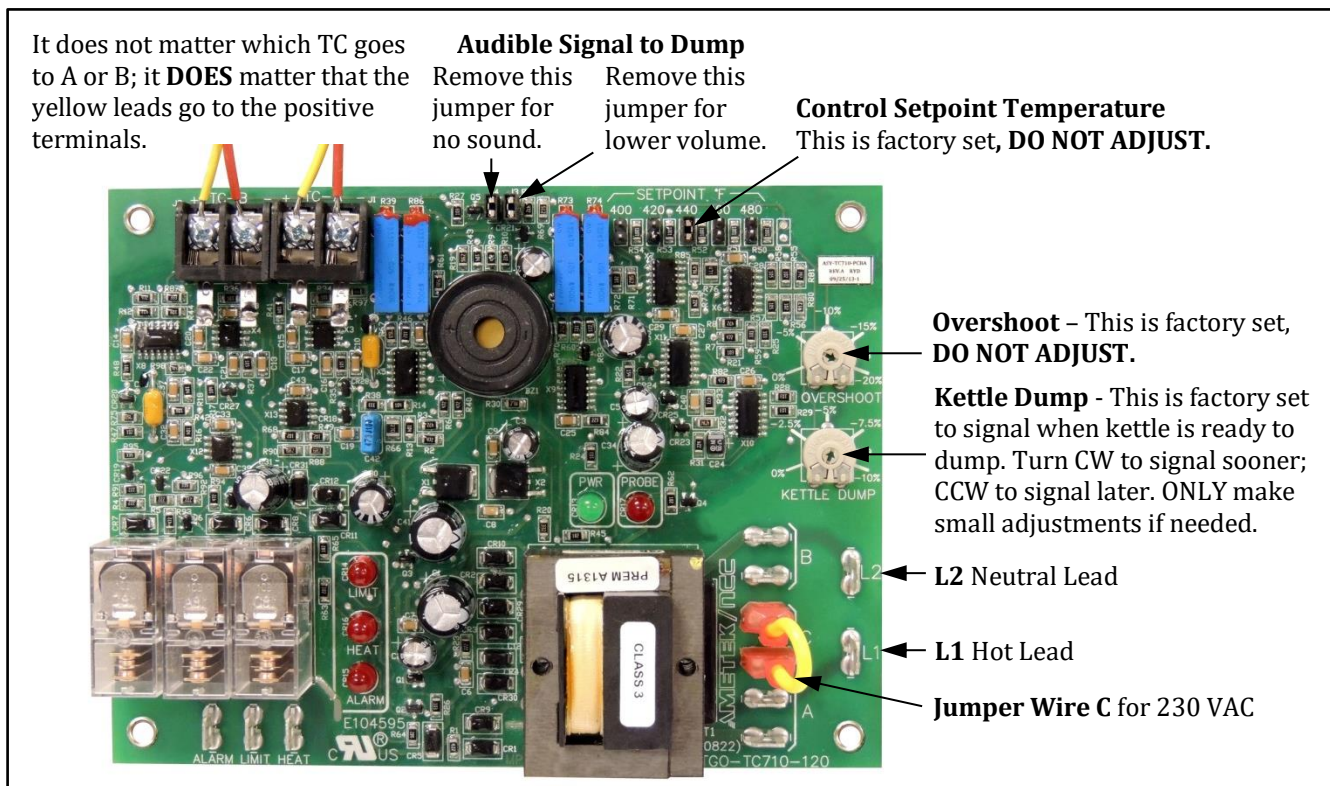

Qualified service personnel only please see Appendix A, Service Bulletin 0074



---

## ORDERING SPARE PARTS

1. Identify the needed part by checking it against the photos, illustrations, and/or parts list.
2. When ordering, please include part number, part name, and quantity needed.
3. Please include your model number, serial number, and date of manufacture (located on the machine nameplate) with your order.
4. Address all parts orders to:

Parts Department  
Gold Medal Products Co.  
10700 Medallion Drive  
Cincinnati, Ohio 45241-4807

Or, place orders by phone or online:

Phone: (800) 543-0862  
(513) 769-7676  
Fax: (800) 542-1496  
(513) 769-8500  
E-mail: [info@gmpopcorn.com](mailto:info@gmpopcorn.com)  
Web Page: [gmpopcorn.com](http://gmpopcorn.com)

### Replacing Broken Glass

If you accidentally break a panel of glass, it can be replaced very easily without disassembling the popper. Gold Medal Products does not ship glass. Obtain from local glass shop and always purchase double strength type glass.

1. Remove all loose pieces of glass.
2. Remove all rigid glass channels from around the glass to be replaced. Set it aside as it must be reused.
3. Carefully remove the rest of broken glass.
4. Apply decals to the new glass panel.
5. Slide rigid glass channels over the exposed sides and bottom. Front and side glass slide under top and is then lowered into bottom channel.

# CABINET BREAKDOWN



Item	Part No.	Model(s)	Part Description	Qty.
1	63477	ALL	DOME WELDMENT	1
2	41349	ALL	MALE HINGE SHORT LEFT	2
3	41352	ALL	FEMALE HINGE LONG LEFT	2
4	41350	ALL	MALE HINGE SHORT RIGHT	2
5	41351	ALL	FEMALE HINGE LONG RIGHT	2
6	41013	ALL	DOOR KNOB	2
7	50013	ALL	MAGNET	2
8	63755	ALL	DOOR	2
9	63554	ALL	DROP PANEL	1
10	49666	ALL	DOOR STOP	1
11	63426	ALL	CONTROL BOX WELDMENT	1
12	48907	ALL	HANGER ARM	1
13	48908	ALL	HANGER ARM WITH "CLEAN-IN-PLACE"	1



## Cabinet Breakdown

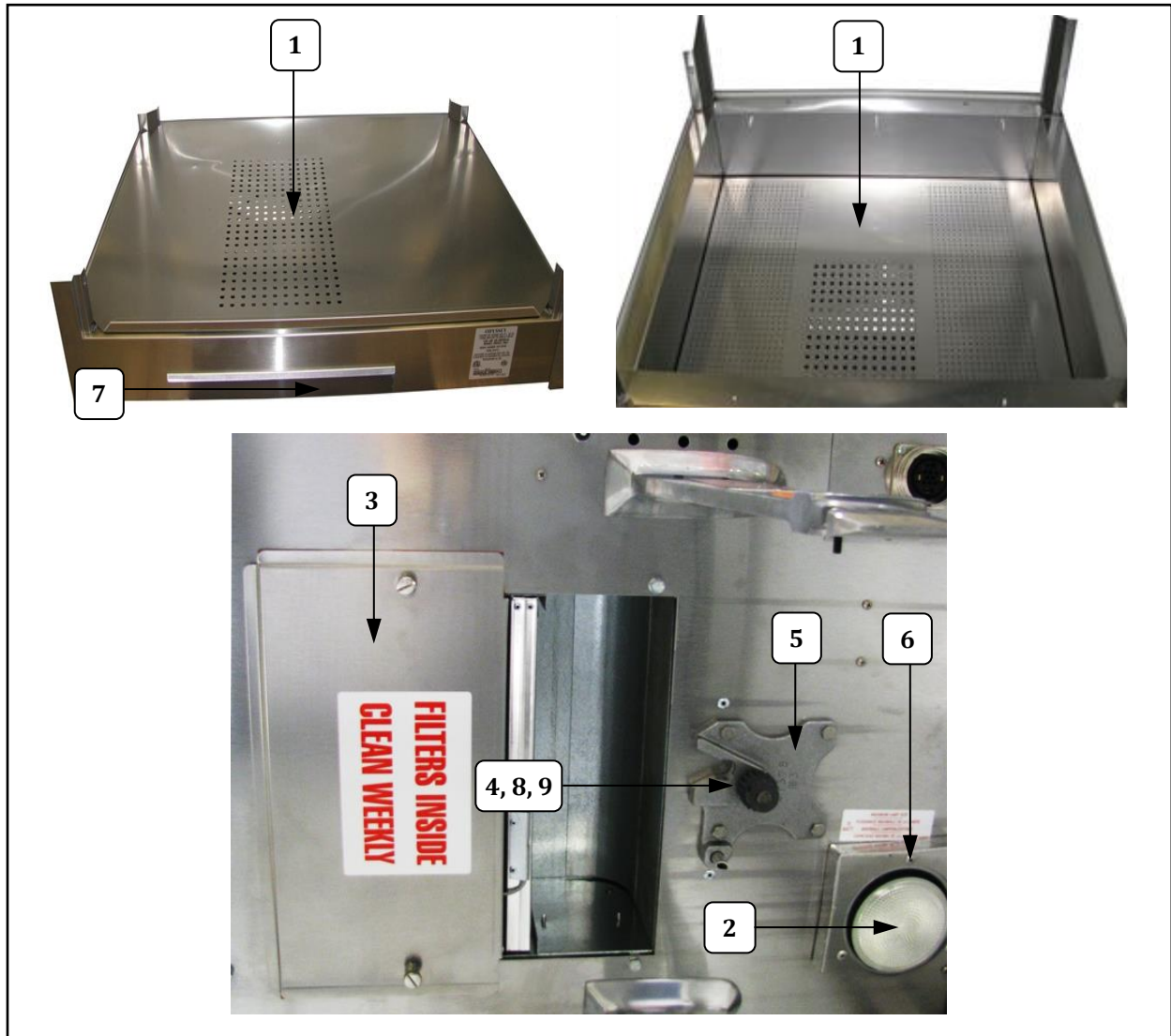

ITEM	PART NO.	MODEL(S)	PART NAME	QTY.
1	63384	Non Deep Well	Old Maid Screen	1
	63718	Deep Well	Old Maid Screen	1
	63454	Japan	LH Old Maid Screen (Not Shown)	1
	63455	Japan	RH Old Maid Screen (Not Shown)	1
2	41979S	Domestic	75W Halogen Flood	2
	41979EX	Export	75W 240V Halogen Flood	
3	41934	All	Cover Assy.	1
4	41380	All	Spur Gear	1
5	41432	All	Gear Block Assy.	1
6	49584	All	Light Cover	1
7	63808	Deep Well	*Old Maid Pan	1
	40276	Non Deep Well	Old Maid Pan	
8	41730	All	Woodruff Key	1
9	41742	All	Set Screw	1

## Cabinet Breakdown

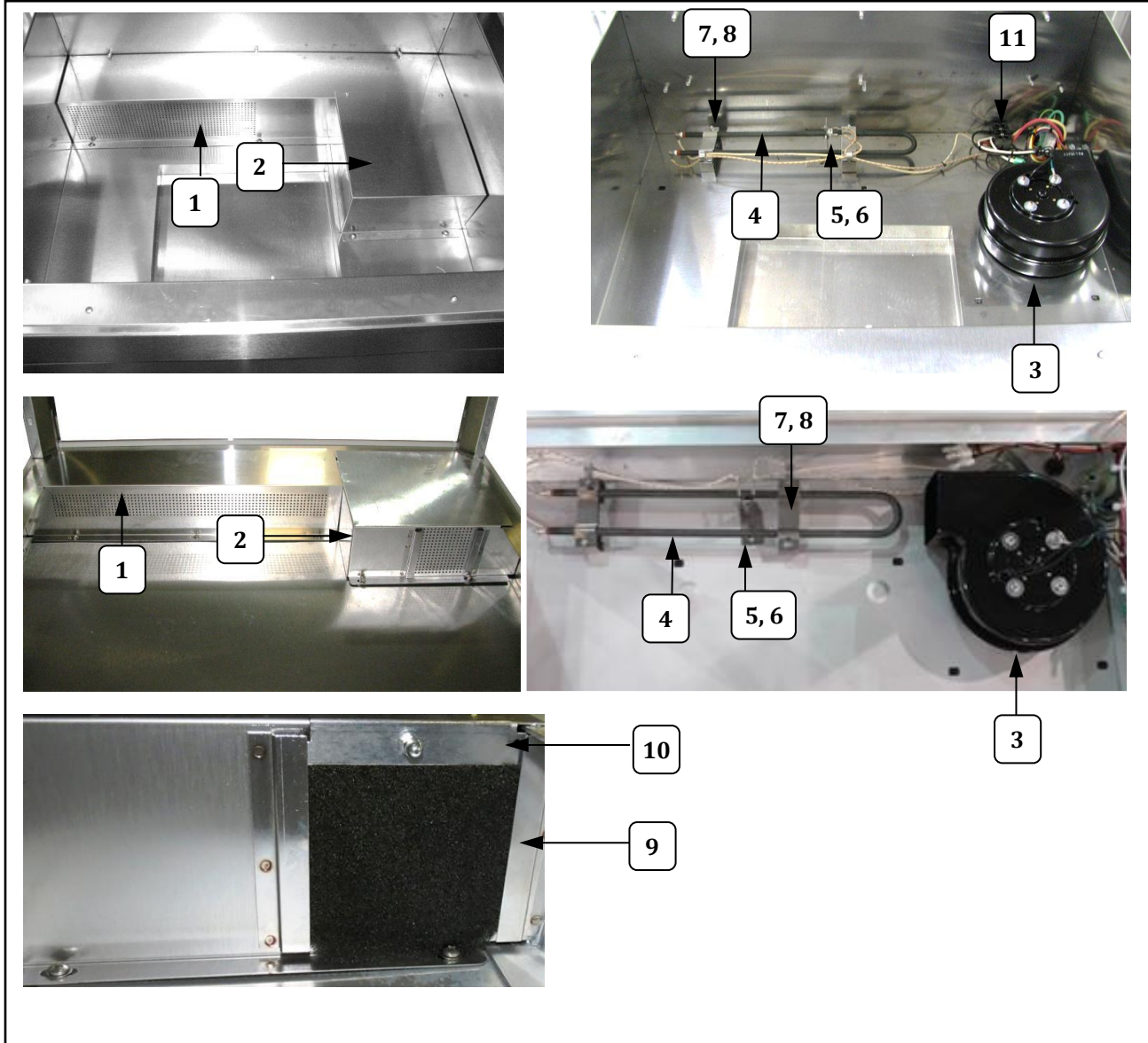

ITEM	PART NO.	MODEL(S)	PART NAME	QTY.
1	63386	Non Deep Well	Diffuser Cover Weldment	1
	63717	Deep Well	Diffuser	1
2	63383	Non Deep Well	Blower Cover Weldment	1
	13406	Deep Well	Blower Housing	1
3	61123	Domestic	120V Blower	1
	61124	Export	230V Blower	1
4	61128	Domestic	120V 800W Heat Element	1
	61135	Export	230V 800W Heat Element	1
5	55496	ALL	260°F Thermostat	1
6	55500	ALL	Thermostat Mounting Bracket	1
7	61133	ALL	Heater Clamp	2
8	61134	ALL	Heater Mount	2
9	63633	ALL	Filter	1
10	63634	ALL	Filter Retainer	1
11	55272	ALL	Terminal Block	1

# POPCORN SIGN BREAKDOWN

## Neon Sign Options – 63470N

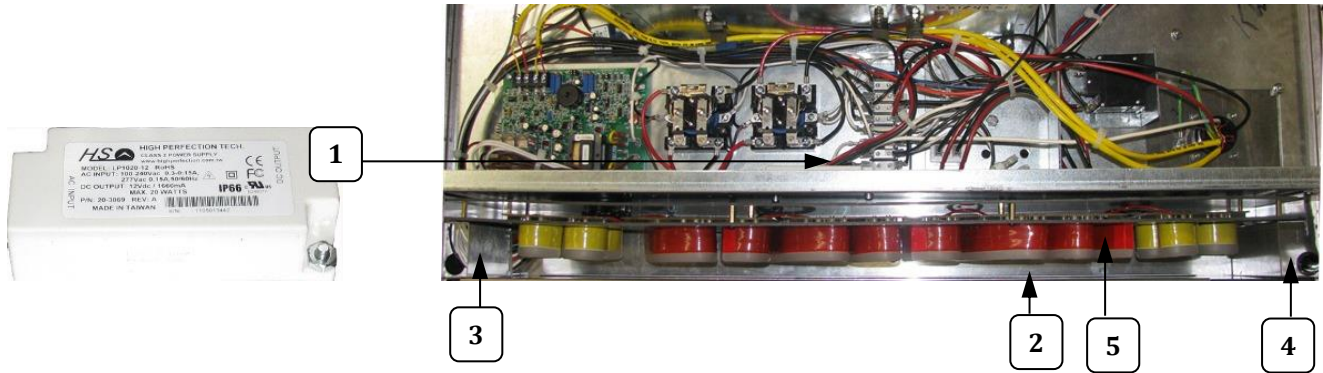

## Fluorescent Sign Options – 63470

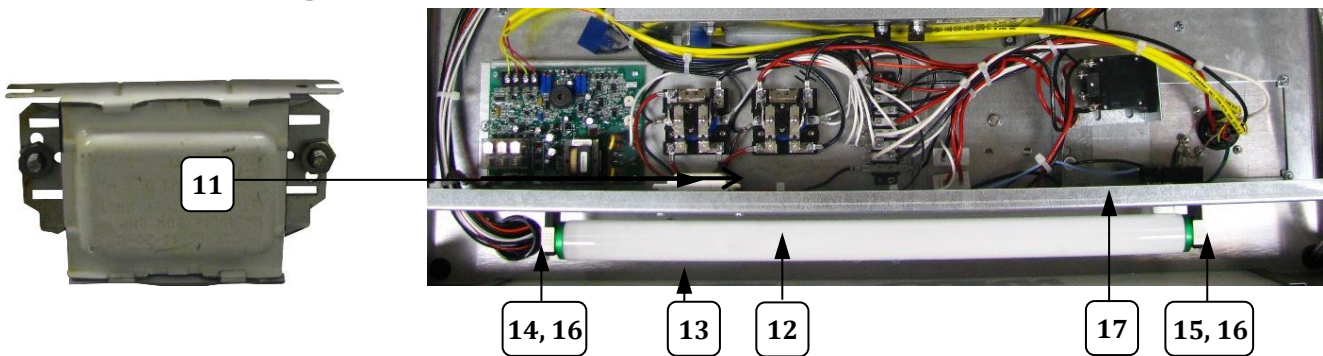

## LED Sign Options – 63470L

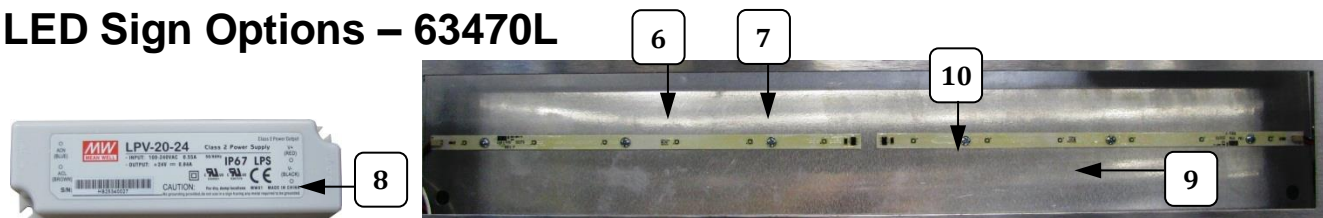

ITEM	PART NO.	MODEL(S)	PART NAME	QTY.	ITEM	PART NO.	MODEL(S)	PART NAME	QTY.
1	55231	NEON	12V Power Supply	1	11	41022	Domestic	120V 60Hz Light Ballast	1
2	63809	NEON	Neon Sign Cover	1		48777	Export	Universal Ballast	1
3	63498	NEON	Neon Bracket LH	1	12	16264	ALL	20W Fluorescent Bulb	1
4	63499	NEON	Neon Bracket RH	1	13	55356	ALL	Popcorn Sign (Not Shown)	1
5	69707	NEON	Neon Lighted Sign	1	14	41020	ALL	Light Tube Holder	1
6	41301	LED	Lighted Sign (Not Shown)	1	15	41021	Domestic	Light Tube Holder Starter	1
7	55424	LED	Light Filter (Not Shown)	1	16	12502	ALL	Tube Lock	2
8	55394	LED	24VDC 20W Power Supply	1	17	41023	Domestic	Light Starter	1
9	39656	LED	LED Mounting Plate	1					
10	55379	LED	1W LED Strip	2					

# BASE BREAKDOWN

## Non Deep-Well Base

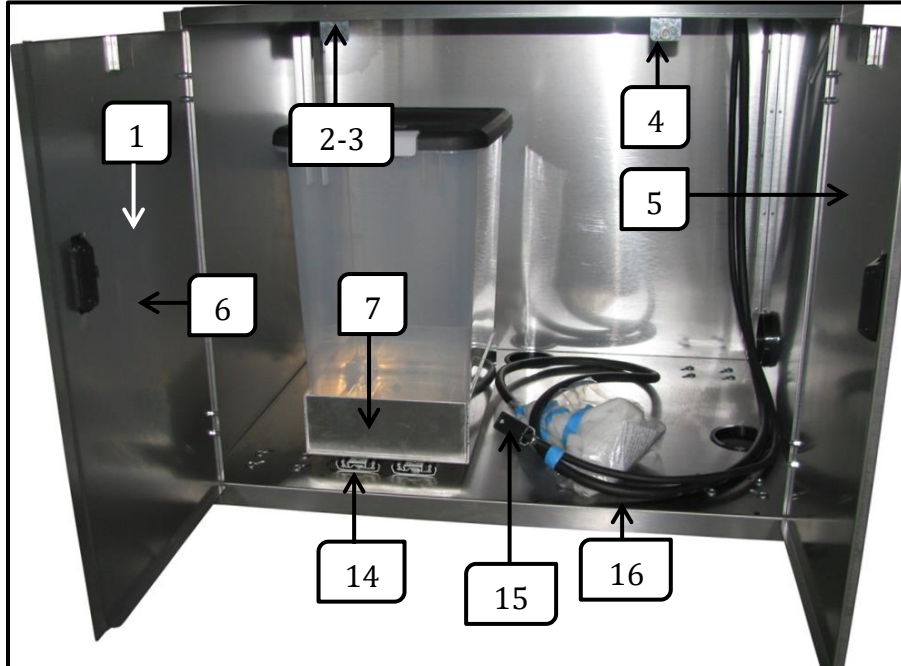

## Deep-Well Base

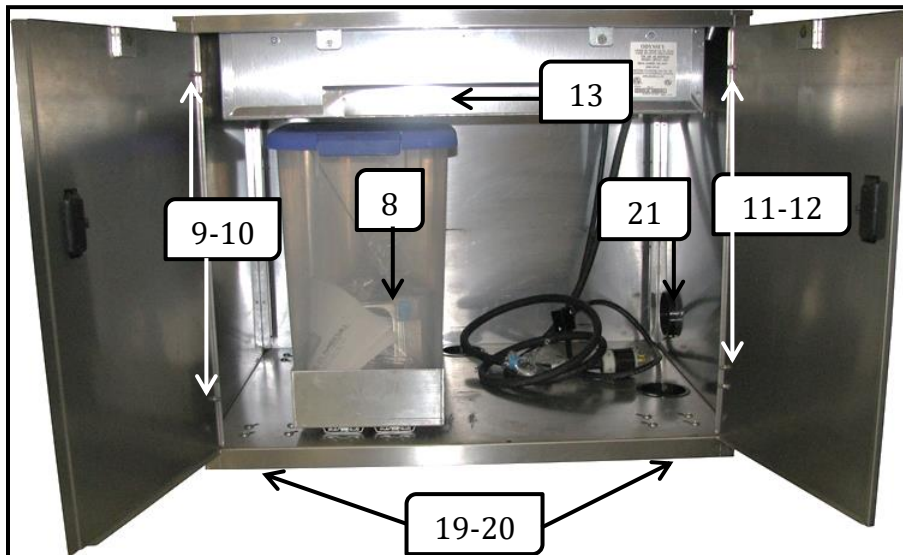

*\*NOTE: Old Maid Pan is located above the doors on the non-deep well versions of this unit, not inside as shown in figure above.*

## BASE PARTS LIST

ITEM	PART NO.	MODEL(S)	PART NAME	QTY.
1	82698	ALL	Flush Mount Handle	2
2	50013	ALL	Magnet	2
3	68115	ALL	Magnet Spacer	1
4	83050	ALL	Door Catch Bracket	2
5	63752	ALL	Base Door Right	1
6	63751	ALL	Base Door Left	1
7	63418	ALL	Corn Bin Bracket	1
8	63417	ALL	Corn Bin	1
9	41349	ALL	Male Hinge Short Left	2
10	41355	ALL	Female Hinge Left	2
11	41350	ALL	Male Hinge Short Right	2
12	41354	ALL	Female Hinge Right	2
13	63716	Deep Well	Deep Well Weldment	1
14	63773	ALL	Drawer Slide Pair	1
15	41499	ALL	Oil Pump Wire Harness	1
16	16050	Domestic	Lead-In Cord Assy.	1
	82943	Export	Export Lead-In Cord	1
17	48646	Japan	1.5KVA Boost Transformer	1
18	82587EX	Japan	1.5KVATransformer Cover	1
19	37513	ALL	Swivel Caster W/O Lock	2
20	37514	ALL	Swivel Caster W Lock	2
21	67804	ALL	Bushing Snap	3

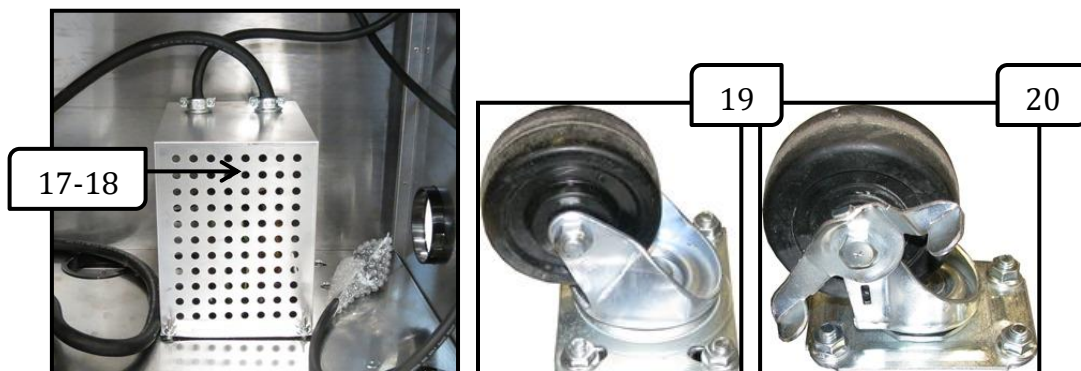



# 52 oz. Kettle Assembly – 2727HT (Domestic), 2727HTX (Export)

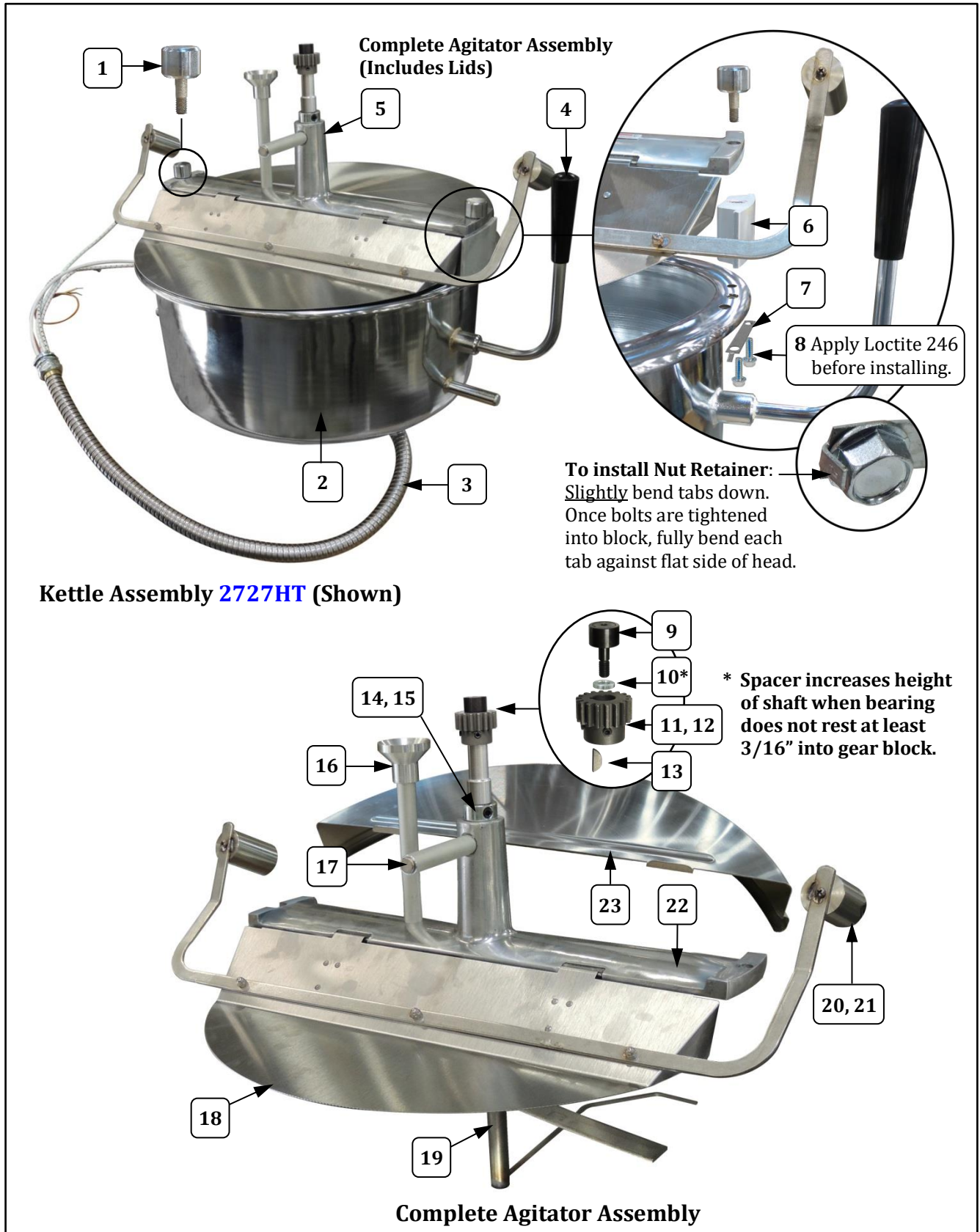



## 52 oz. Kettle Assembly – 2727HT, 2727HTX - Parts List

Item	Parts Description	Part Number	
		2727HT	2727HTX
1	CROSSBAR FASTENER	47977	47977
2	RH KETTLE BOTTOM ASSY (see Kettle Bottom Assembly section for parts breakdown)	55300	48966EX
3	KETTLE LEAD ASSEMBLY	55299	55299
4	DUMP HANDLE PLASTIC	41139	41139
5	52 OZ LID AGITATOR ASSY (Complete Assy)	48961HT	48961HT
6	BLOCK/LID ASSY	46094	46094
7	NUT RETAINER	69315	69315
8	1/4-20 X 3/4 - 3/8 HEX (Apply Loctite 246 to bolts before installing.)	106038	106038
9	BEARING, CAM FOLLOWER	61225	61225
10	SPACER (used to increase shaft height when Cam Follower Bearing does not rest at least 3/16" into Gear Block)	106035	106035
11	SPUR GEAR	41380	41380
12	SET SCREW #10-32 X 3/16	41742	41742
13	WOODRUFF KEY #3 1/8 X 1/2	41730	41730
14	SHAFT COLLAR 5/8 IN	68761	68761
15	SET SCREW 5/16-18 X 3/8	74127	74127
16	OIL TUBE W/FUNNEL	47689	47689
17	MAGNET HOLDER ASSY 52 OZ (includes magnet and holder)	67926	67926
18	52 OZ REMOVABLE FRONT LID	68069	68069
19	AGITATOR WELD ASSY 52 OZ.	68121	68121
20	COUNTER WEIGHT, W-8/32 TAP	82108	82108
21	8-32 X 3/8 PH PAN HD M/S	42226	42226
22	CROSSBAR ASSY 52 OZ.	48965HT	48965HT
23	52 OZ FIXED REAR LID	67917	67917

# 52 oz. Kettle Bottom Assembly – 2727HT, 2727HTX

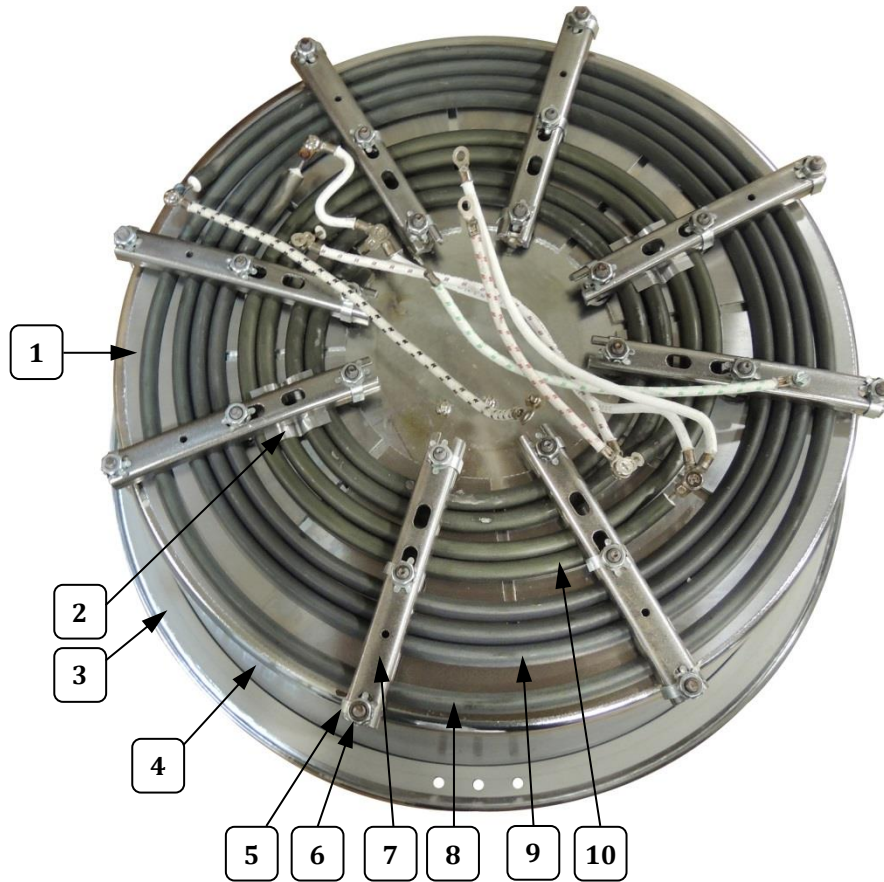

**Element View - Interior**

\* See Parts List for note  
On Pass Thru Models.

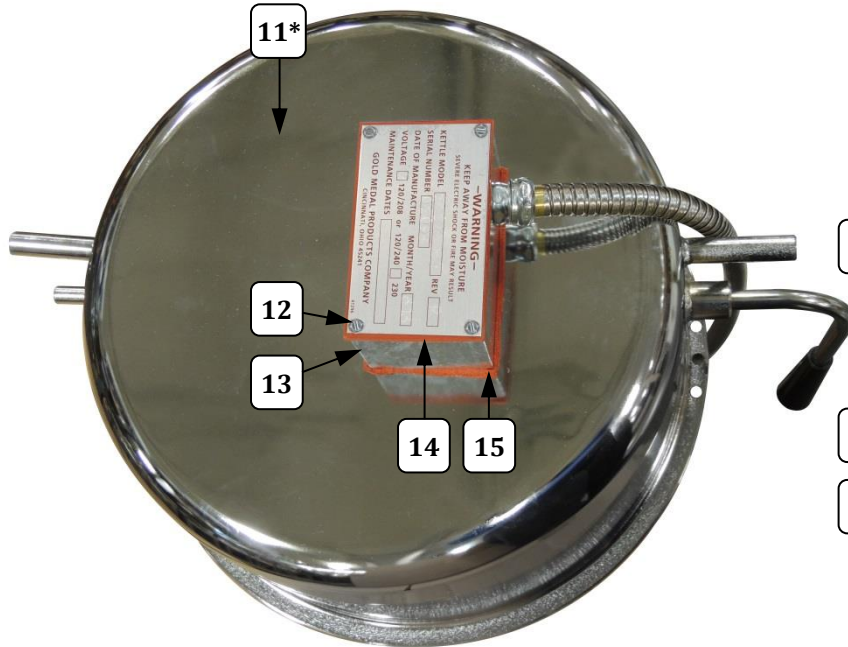

**Kettle Shell - Bottom View**

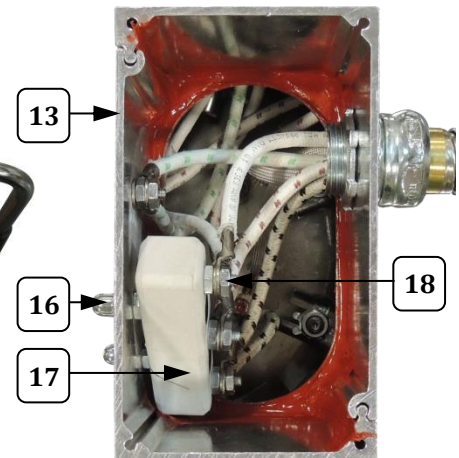

**Junction Box Interior View**



## 52 oz. Kettle Bottom Assembly – 2727HT, 2727HTX – Parts List

Item	Part Description	Part Number	
		2727HT	2727HTX
	RH KETTLE BOTTOM ASSY (Complete Assembly - includes all parts listed below)	55300	48966EX
1	HEAT TRANSFER PLATE 52 OZ.	48968	48968
2	ELEMENT SHIM	68787	68787
3	KETTLE GASKET	48958	48958
4	52 OZ KETTLE WELDED ASSY	48957	48957
5	NUT RETAINER	50190	50190
6	HEX NUT 1/4-20	74133	74133
7	ELEMENT CLAMP 48, 52, 66OZ	68780	68780
8	HEAT ELEMENT, 2700W	46491	46498
9	TUBULAR ELEMENT, 1800W	48650	48650EX
10	TUBULAR ELEMENT, 1050W	48651	48651EX
11	KETTLE SHELL WELD	48959	48959
12	8-32 X 1/2 SLOTTED H W H (Screw)	49379	49379
13	JUNCTION BOX ASSEMBLY	55311	55311
14	JUNCTION BOX GASKET (between Junction Box and Cover)	40965	40965
15	JUNCTION BOX GASKET (between Kettle and Junction Box)	40963	40963
16	ACORN NUT #8-32	47702	47702
17	KETTLE TERMINAL BLOCK	41129	41129
18	8-32 HEX M/S NUT	74149	74149

# Top Motor Plate

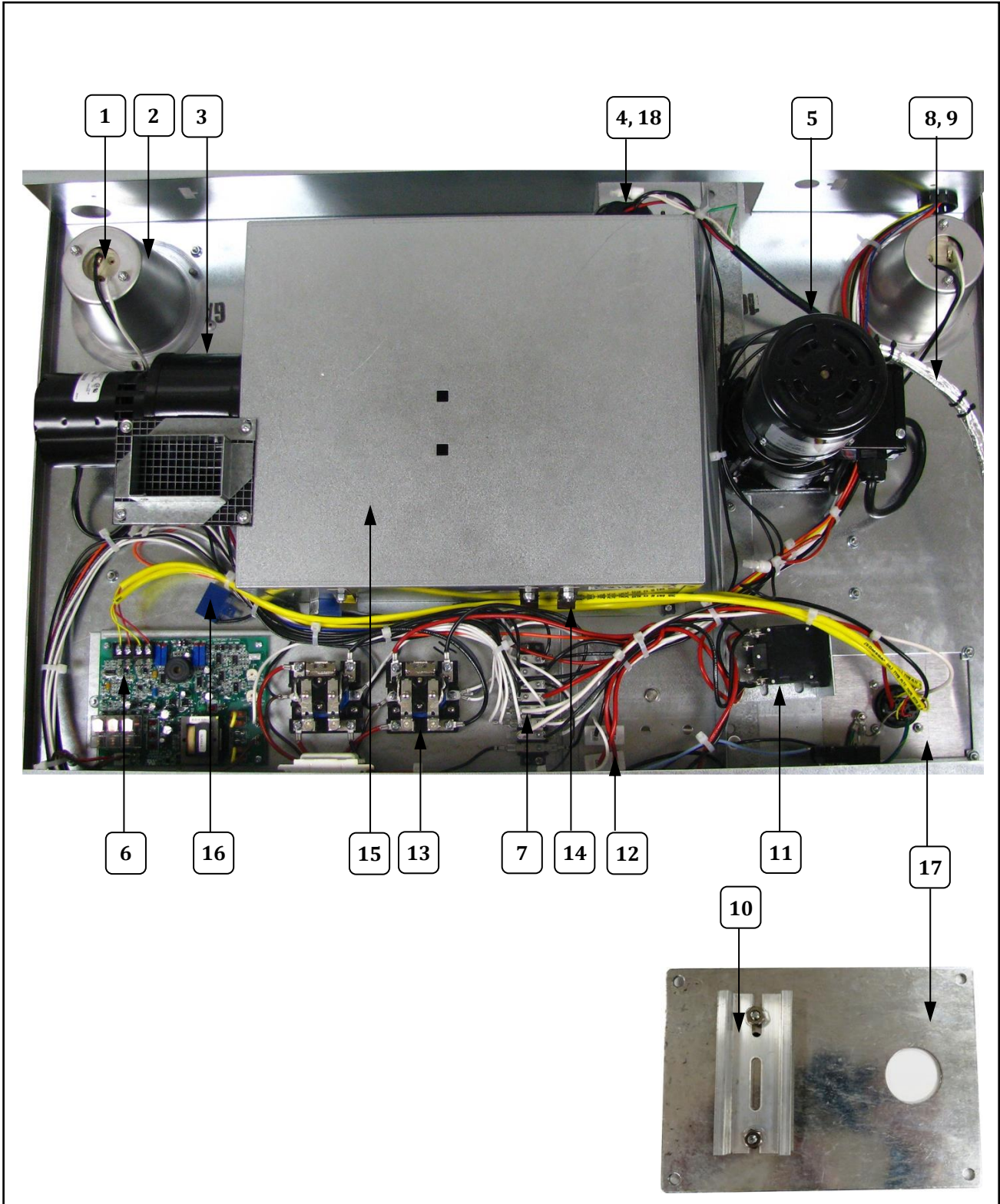



## Top Motor Plate

Item	Part No.	Model(s)	Part Description	Qty.
1	47047	ALL	LAMP HOLDER	2
2	49584	ALL	RECESSED LIGHT COVER	2
3	41015	DOMESTIC	115V EXHAUST BLOWER	1
	41965	EXPORT	220V EXHAUST BLOWER	
4	46107	ALL	MOTOR CAPICATOR	1
5	41449B	DOMESTIC	KETTLE DRIVE MOTOR	1
	41500B	EXPORT	KETTLE DRIVE MOTOR	
6	41001	ALL	TEMPRATURE CONTROL	1
7	47208	ALL	TERMINAL BLOCK	1
8	41640	DOMESTIC	120V 8W FOIL ELEMENT	1
	41640EX	EXPORT	230V 8W FOIL ELEMENT	
9	41047	ALL	OIL LINE TUBING	5'
10	62252	ALL	DIN RAIL	1
11	55223	DOMESTIC	26A CIRCUIT BREAKER	1
	55224	EXPORT	10A CIRCUIT BREAKER	
12	47364	DOMESTIC	15A CIRCUIT BREAKER	2
	48659	EXPORT	10A CIRCUIT BREAKER	
13	55219	DOMESTIC	30A DPST CONTROL RELAY	2
	55562	EXPORT	IEC CONTACTOR 4 POLE 30A	
	55219	FLEXI-POP	RELAY, 30A DPST 120V	3
14	62666	ALL	FILTER SPRING CLIPS	3
15	41918	ALL	BLOWER BOX WELDMENT	1
16	89087	ALL	240VAC TRANSIENT FILTER	2
17	55293	ALL	3/4IN PLATE, HARD WIRE	1
18	48301	ALL	CAPACITOR STRAP	1
19	48673	FLEXI-POP	HEAT SINK (not shown)	1
20	48675	FLEXI-POP	PHASE CONTROL (not shown)	1
21	48645	FLEXI-POP	RELAY, 120VAC, DPDT (not shown)	2



---

# WIRING DIAGRAM

**For wiring information, please reference  
the Wiring Diagram shipped with the popper.**



# GOLD MEDAL PRODUCTS COMPANY

10700 Medallion Drive  
Cincinnati, Ohio 45241-4807  
U.S.A.

Phone: (513) 769-7676  
Fax: (513) 769-8811

## ***SERVICE BULLETIN 0074***

***Date Issued*** – 8/23/04      REVISED 1/28/14

***Model(s) Affected***- All Poppers with NCC Electronic Temperature Control

This bulletin describes popcorn machines equipped with an Electronic Temperature Control manufactured by NCC for Gold Medal Products. There are no mechanical thermostats used with this control. The mechanical thermostats are replaced by two Thermocouple Sensors, one for the High Limit and one for Temperature Control. This model is also equipped with a beeper and an indicator light that activate when the kettle heat switch is on and the kettle is at or over the dump temperature set point.

***Note:*** All components listed in this service bulletin are shown in Figure 1 on page 5).

### **Operation**

The control is factory set to a temperature which stops power to the kettle when the thermocouple in the kettle reaches the set temperature. See Table 1 for a list of temperature jumper settings. There is a Kettle Dump Potentiometer that is used to set the Alarm point for loading and dumping the kettle. This potentiometer will subtract up 10% of the set point jumper value to fine tune the alarm point. If the kettle heat switch is turned on and the beeper is sounding *one of the* following actions should be taken:

1. Load the corn and oil *or*
2. Dump the popped corn from the kettle *or*
3. Turn off the kettle heat switch if you are finished popping corn.

The High Limit Control is fixed at 550°F and cannot be adjusted.

### **Overshoot Potentiometer**

For a **stainless steel kettle** the Patented First Time Overshoot Circuit Potentiometer is set to -20%, full clockwise (CW). DO NOT change this setting. This setting prevents the kettle from getting too hot during the first time heat up.

When power is applied to the kettle and the kettle temperature is below the first time overshoot temperature set point the power to the kettle will be turned off at the overshoot temperature. The alarm will NOT sound. The kettle will then cool to a point below the first time overshoot value and start to reheat. When the kettle reaches the alarm temperature the alarm will sound and it is time to load the kettle with corn and oil. The kettle will now operate from the alarm and jumper set points. The first time overshoot set point is based on the power set point jumper setting. For example if the power set point jumper is set at 460°F the first time overshoot set point will be 368°F (460°F-92°F). The 92°F is 20% of the 460°F value.



### **Adjustment of Alarm Set Point**

If you would like to have the beeper sound sooner or later than the factory setting, adjust the temperature setting as follows:

1. To sound the beeper sooner, turn the Kettle Dump pot clockwise (CW) towards the -10% mark on the control board. This will lower the alarm set point without changing the power set point jumper value. For example if Set Point jumper is set at 400°F and the Kettle Dump pot is at -5% the kettle alarm temperature will be 380 °F (400°F - 20°F), the power set point stays at 400°F. If the pot is set at 0% the alarm and power set points are the same, 400°F. If the pot is set at -10% the alarm set point is 360°F (400°F - 40°F) and the power set point is 400°F. A change of 1% CW on the potentiometer will subtract about 3 seconds from the alarm set point.
2. To sound the beeper later, turn the Kettle Dump pot counterclockwise (CCW). A change of 1% CCW on the Dump potentiometer will add about 3 seconds to the alarm set point.

### **Adjustment of beeper Sound Level**

If you would like to lower the beeper volume, remove jumper J3 shown in figure 1. To stop the beeper remove jumper J4.

### **Salt / Sweet Option**

The control board will have two separate set point jumpers. The lower value jumper is the sweet temperature. These jumpers have wires attached to them going directly to a salt/sweet switch or a salt /sweet relay. The salt/sweet switch selects which jumper is active.

**Factory Set Point Jumper Settings**

<b>Model</b>	<b>Temperature Salt °F</b>	<b>Temperature Sweet °F</b>	<b>Overshoot Potentiometer</b>
Macho Pop/Pappy's	460	400	-20%
2102E Citation	440	400	-20%
52 oz. Medallion	460	420	-20%
32 Oz. Pop-O-Gold	440	400	0%
2010 Astro Pop	460	420	0%
36 oz. Cornado	440	400	-20%
48 oz. Cornado	440	400	-20%

**Table 1**



### **Trouble Shooting for Service Personnel**

1. If the kettle does not heat and there are no beeper sounds, look on the heat control to see if the green PWR LED is on. The PWR LED indicates there is power to the control board. If the LED is not on, check the Heat Switch and wiring. Check for 120 VAC (230 VAC) across terminals L1 & L2.
2. If the kettle does not heat and/or the beeper sounds continuously check to be sure there is a set point jumper in one of the 6 locations. Remove the jumper and clean the pins off, sometimes the conformal coatings gets on the pins and acts as an insulator.
3. If the kettle does not heat and/or the beeper sounds continuously, look on the heat control to see if the red Probe LED is on. The Probe LED indicates there is a thermocouple problem.
  - a. If the Probe LED is **on** and the Limit & Heat LED's are **off** and the beeper is **on** there is a problem with the Heat Thermocouple, TC-B wiring. Look at the terminal blocks for a loose connection. Check the kettle wiring for a loose or broken thermocouple wire.
  - b. If the Probe and Heat LED's are **on** and the beeper is **off** there is a problem with the Limit thermocouple, TC-A wiring. Look at the terminal blocks for a loose connection. Check the kettle wiring for a loose or broken thermocouple wire.
  - c. If the Probe LED is **not on** the thermocouple connections are **OK**. If the Limit LED and Alarm LED's are **on** and the beeper is **on** check the Set Point Jumpers. Most likely the jumper has come off. If the Jumper is in place temporarily move it to a different temperature setting to see if the control then works.
4. If the kettle heats for a short time and then stops.
  - a. If the Probe, Heat and Alarm LED's are **on** and the beeper is **on** the Heat Thermocouple, TC-B is wired reverse. Check for reversed thermocouple leads, see note 2 below. If the thermocouple leads are reversed the kettle will heat up to about 240°F and stop with the Probe LED on. The leads could be reversed at either the heat control itself or the terminal block.
  - b. If the Probe and Heat LED's are **on** and the beeper is **off** the Limit Thermocouple, TC-A is wired reverse, troubleshoot as in item 3-a above. Note this is similar to 2-b above, the difference is the kettle started to heat and then quit.
5. The kettle is popping normally but the beeper does not sound, check for a missing jumper at J4.
6. Salt or Sweet temperature is not working correctly. Check to make sure both temperature set point jumpers are in place and wired correctly. Be sure the common wire for the switch or relay is connected to a bottom pin of one of the set point jumpers.

**Notes:**

1. Do **not** adjust the (4) painted potentiometers numbers R89, R36, R73 and R74 on the electronic heat control. If adjusted, the performance will be erratic and could result in an over temperature condition.
2. Thermocouple wire consists of (2) different wires made of different materials that are color-coded polarity. It is important that red (-) is connected to red (-), and yellow (+) is connected to yellow (+), at the lead-in plug, the receptacle, and at the electronic heat control. Note that the red lead is magnetic if you have trouble determining which is which.
3. This control includes a patented first time overshoot circuit. On power up if the kettle is below the first time overshoot temperature it is normal for the heat light to go off and the kettle to stop heating before the set dump temperature. The kettle will continue to heat as soon as the kettle temperature drops below the first time overshoot temperature.
4. The Limit, Heat and Alarm LED's indicate the state of the output relays of the temperature control board. If an output LED is lit there should be 120 VAC on the respective ¼" faston with respect to common. The main voltage to the temperature control must be wired such that the hot 120 VAC (230 VAC) is connected to L1. The L2 connection is for the neutral or common voltage wire.

If you have any questions, please feel free to call **Technical Service** or **Engineering** at **Gold Medal Products Co.** Toll Free Phone Number **1-800-543-0862**



# Temperature Control Board

**TC-A** is the Limit Thermocouple Input. + is Yellow Wire.

**TC-B** is the Control Thermocouple Input. + is Yellow Wire.

**Beeper Off/On Jumper** Remove for no sound.

**Beeper Volume Jumper**. Remove for lower sound.

**Set Point Jumper** See Table 1 for Location.

**Salt/Sweet Option** - there are two jumpers with wires. The common wire (white) is connected to a bottom jumper pin.

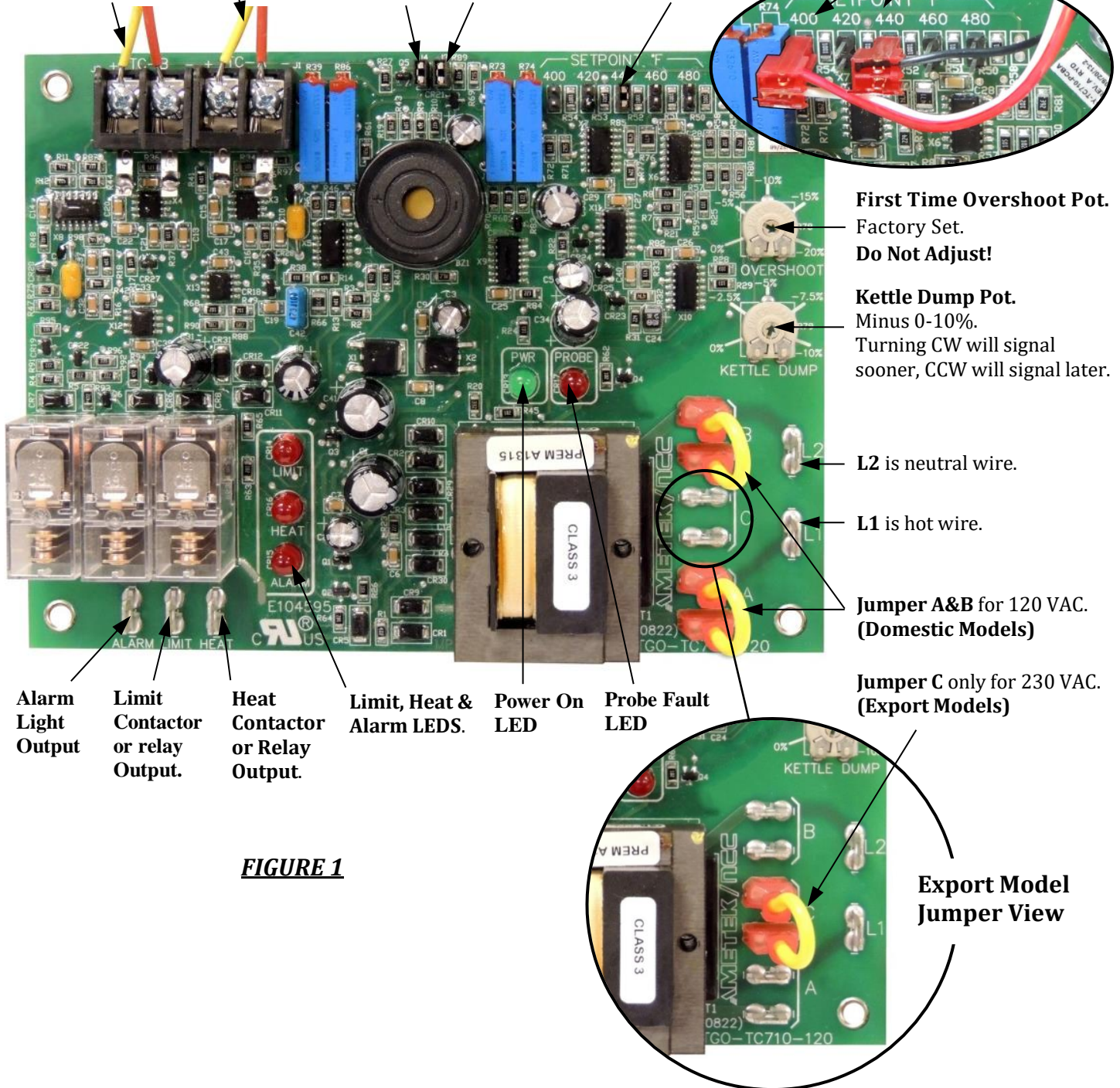

**First Time Overshoot Pot.** Factory Set. **Do Not Adjust!**

**Kettle Dump Pot.** Minus 0-10%. Turning CW will signal sooner, CCW will signal later.

**L2** is neutral wire.

**L1** is hot wire.

**Jumper A&B** for 120 VAC. (Domestic Models)

**Jumper C** only for 230 VAC. (Export Models)

**Export Model Jumper View**

**FIGURE 1**

**Alarm Light Output**

**Limit Contactor or relay Output.**

**Heat Contactor or Relay Output.**

**Limit, Heat & Alarm LEDs.**

**Power On LED**

**Probe Fault LED**



## WARRANTY

Gold Medal Products Co. warrants to the original purchaser each item of its manufacture to be free of defects in workmanship and material under normal use and service. Gold Medal Products Co.'s obligation under this warranty is limited solely to repairing or replacing parts, f.o.b. Cincinnati, Ohio, which in its judgment are defective in workmanship or material and which are returned, freight prepaid, to its Cincinnati, Ohio factory or other designated point. Except for "Perishable Parts" on specific machines, the above warranty applies for a period of two (2) years from the date of original sale to the original purchaser of equipment when recommended operating instructions and maintenance procedures have been followed. These are packed with the machine. Parts warranty is two (2) years, labor is six (6) months.

THIS WARRANTY IS IN LIEU OF ALL OTHER WARRANTIES EXPRESSED OR IMPLIED, AND OF ALL OTHER OBLIGATIONS OR LIABILITIES ON OUR PART, INCLUDING THE IMPLIED WARRANTY OF MERCHANTABILITY. THERE ARE NO WARRANTIES WHICH EXTEND BEYOND THE DESCRIPTION ON THE FACE HEREOF. In no event shall Gold Medal Products Co. be liable for special, incidental or consequential damages. No claim under this warranty will be honored if the equipment covered has been misused, neglected, damaged in transit, or has been tampered with or changed in any way. No claim under this warranty shall be honored in the event that components in the unit at the time of the claim were not supplied or approved by Gold Medal Products Co. This warranty is effective only when electrical items have been properly attached to city utility lines only at proper voltages. This warranty is not transferable without the written consent of Gold Medal Products Co.

The term "Original Purchaser" as used in this warranty shall be deemed to mean that person, firm, association, or corporation who was billed by the GOLD MEDAL PRODUCTS CO., or their authorized distributor for the equipment.

THIS WARRANTY HAS NO EFFECT AND IS VOID UNLESS THE ORIGINAL PURCHASER FIRST CALLS GOLD MEDAL PRODUCTS CO. AT 1-800-543-0862 TO DISCUSS WITH OUR SERVICE REPRESENTATIVE THE EQUIPMENT PROBLEM, AND, IF NECESSARY, FOR INSTRUCTIONS CONCERNING THE REPAIR OR REPLACEMENT OF PARTS.

*NOTE: This equipment is manufactured and sold for commercial use only.*



**GOLD MEDAL<sup>®</sup> PRODUCTS CO.**

10700 Medallion Drive, Cincinnati, Ohio 45241-4807 USA

[gmpopcorn.com](http://gmpopcorn.com)

Phone: (800) 543-0862      Fax: (800) 542-1496  
(513) 769-7676              (513) 769-8500