



Parts Catalogue



Model GCM30

MIXERS MODEL:GCM30

1-1-2002

IMPORTANT!

TO EXPEDITE SHIPMENT OF PARTS, ALWAYS SPECIFY MODEL,REV,
PART NUMBER, AND SERIAL NUMBER OF MIXER.

GLOBE FOOD EQUIPMENT COMPANY

2268 N. Moraine Drive

Dayton, Ohio 45439

Parts Department

Toll Free 1-800-745-6238 • Fax (937) 290-0585

E-Mail: globeinfo@globeslicers.com

Website: www.globeslicers.com

Not for resale

1a.	TIMER KNOB	X01214
b.	TIMER	X01215
2a.	START BUTTON	X01216
b.	STOP SWITCH	X01217
c.	START SWITCH	X01218
d.	RED STOP BUTTON	X01234
3.	BALL BEARINGS	X01181
4.	BALL BEARINGS	X01180
5.	PLANETARY SHAFT	X01054
6.	DRIVE SHAFT	X01075
7.	DRIVE PULLEY	X01053
8.	BOWL LIFT ROD	X01204
9.	VARIATOR GROUP	X01239
10.	SPRING RETAINER	●
11.	PULLEY HALF	●
12.	BELT	X01076
13.	TOP COVER	X01149
29.	SAFETY MICROS	X01245
38.	BALL BEARINGS	X01184
39.	SHAFT COUPLING	X01263
40.	STAND OFF(4 REQ.)	X01264
41.	MOTOR COUPLING	X01265
42.	MOTOR *LAFERT	X01242
	*BALDOR	X01242B
	*NERI	X1242N
43.	CONTACTOR	X01235
44.	LOCATING HANDLE	X01247
45.	BOWL	NA
46.	TOOL SHAFT	X01057
47.	SAFETY GAURD	X01053
48.	PLANETARY	X01074
49.	GEAR PROTECTION COVER	X01061
50.	PLANETARY PINION	X01056
51.	INTERNAL TOOTHED CROWN	X01055
52.	LEVELING FOOT	X01266
	*START CAPACITOR LAFERT	X01269
	*START CAPACITOR BALDOR	X01269B
	*RUN CAPACITOR LAFERT	X01270
	*RUN CAPACITOR BALDOR	X01270B
	*RUN CAPACITOR NERI	X01270N
	*THERMAL OVERLOAD	X01272
	*MOTOR RELAY LAFERT	X01271

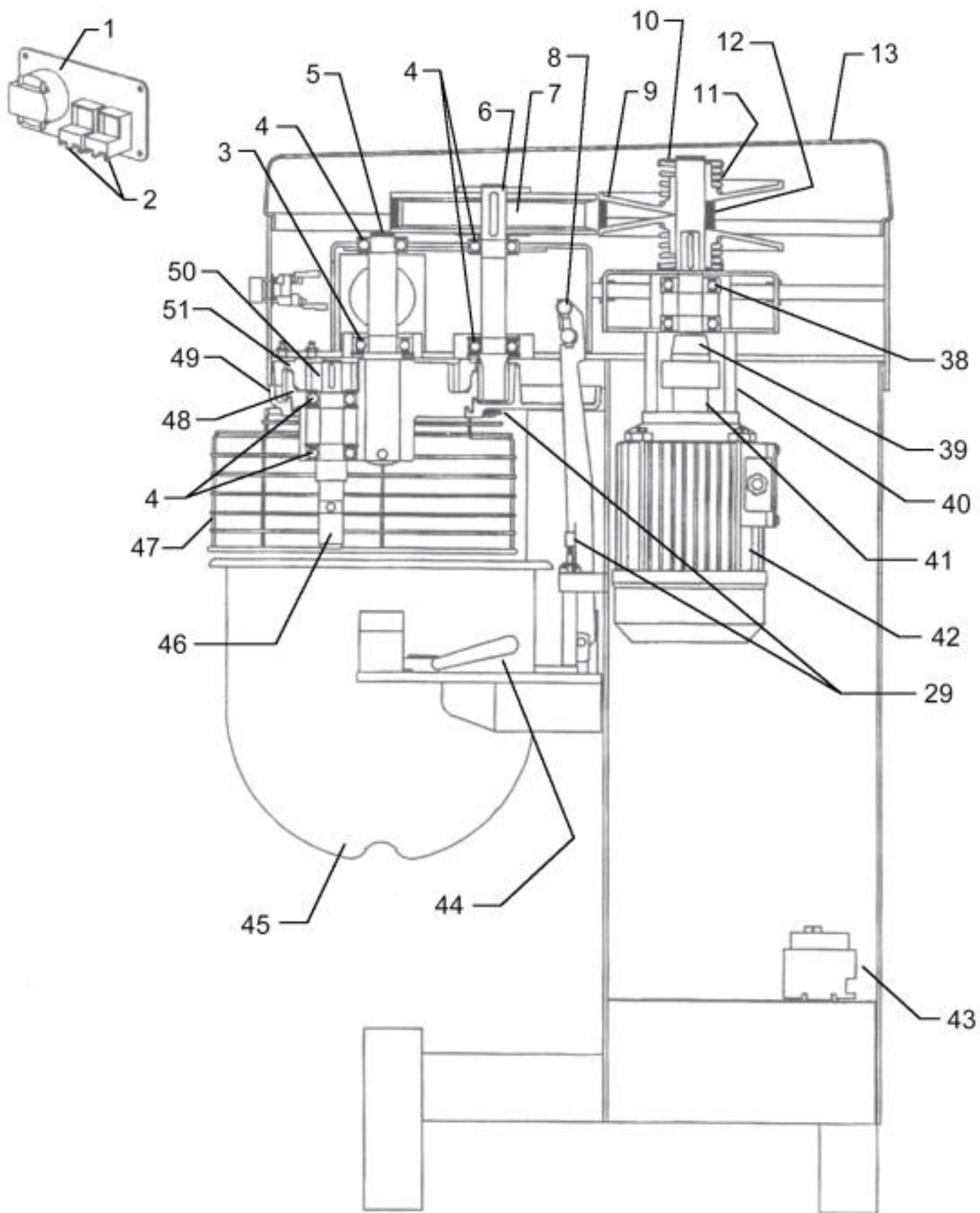

14.	STAY FOR REDUCER	X01059
15.	BALL BEARINGS(2 REQ.)	X01179
16.	BEVEL GEAR PAIR	X01068
17.	BEVEL GEAR	X01058
18.	KNOB(2 REQ.)	X01189
19.	BARS FOR CHAIR	X01080
20.	PULLEY SHAFT	ASSEMBLY
21.	RACK POLE	X01067
22.	SPEED SELECT LEVER	X01025
23.	HANDLE SPRING	X01165
24.	SPEED PIN	X01065
25.	COVER	x01084
26.	SPEED LEVER SUPPORT	X01072
27.	TOOTHED WHEEL	X01066
28.	MOTOR CHAIR	X01144
29.	MICRO SWITCH SAFETY	X01245
30.	MICRO SWITCH BRACKET	X01138
31.	BOWL LOCKING TUBE	X01037
32.	BOWL LIFT CONNECTING ROD	X01063
33.	HOOK AND CLIP	X01205
34.	BOWL LIFTING ROD	X01133
35.	BOWL LIFT LEVER	X01062
36.	PLANETARY FOR REDUCER	X01054
37.	SHAFT FOR HUB	X01060

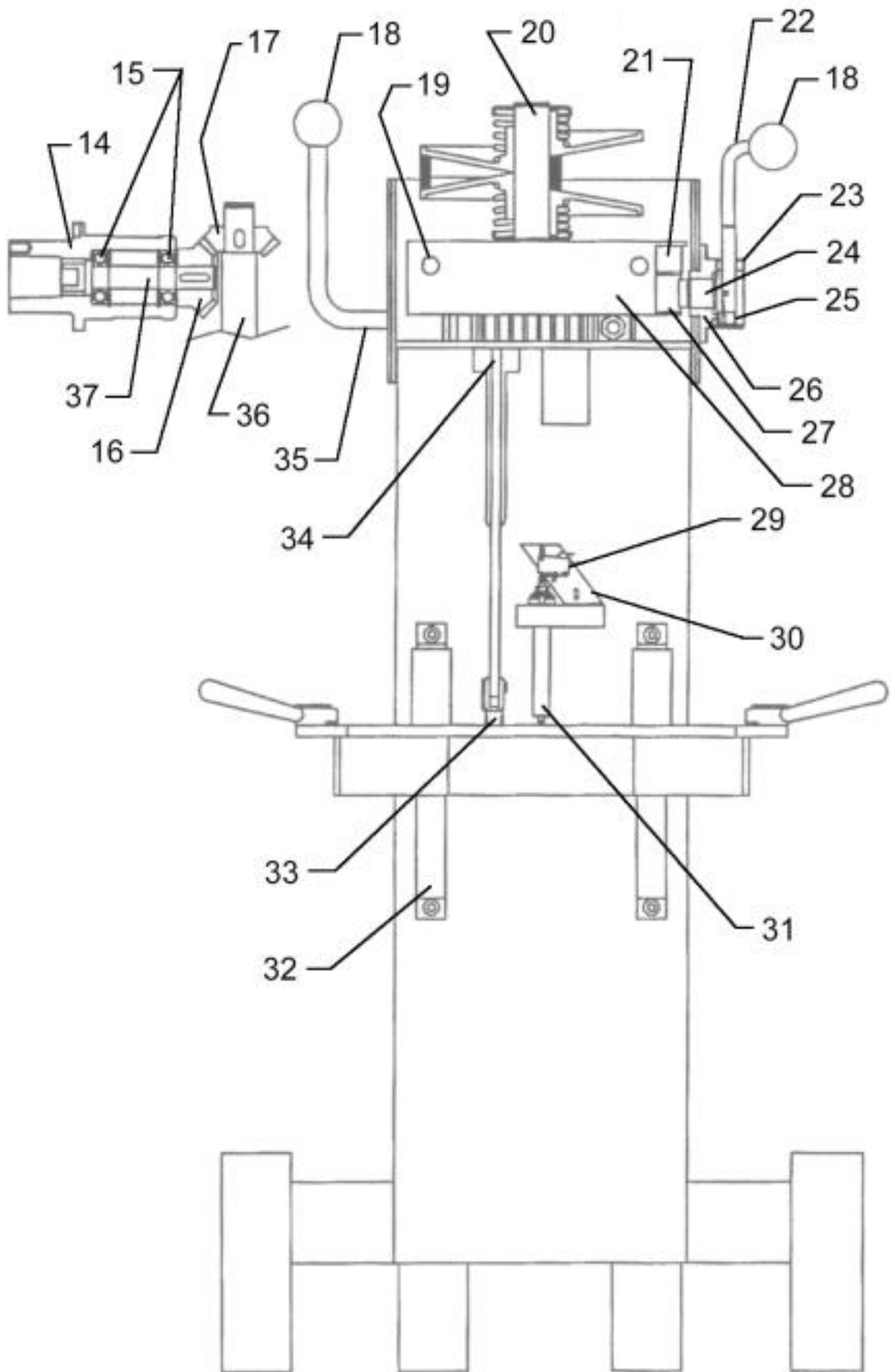

INPUT
POWER

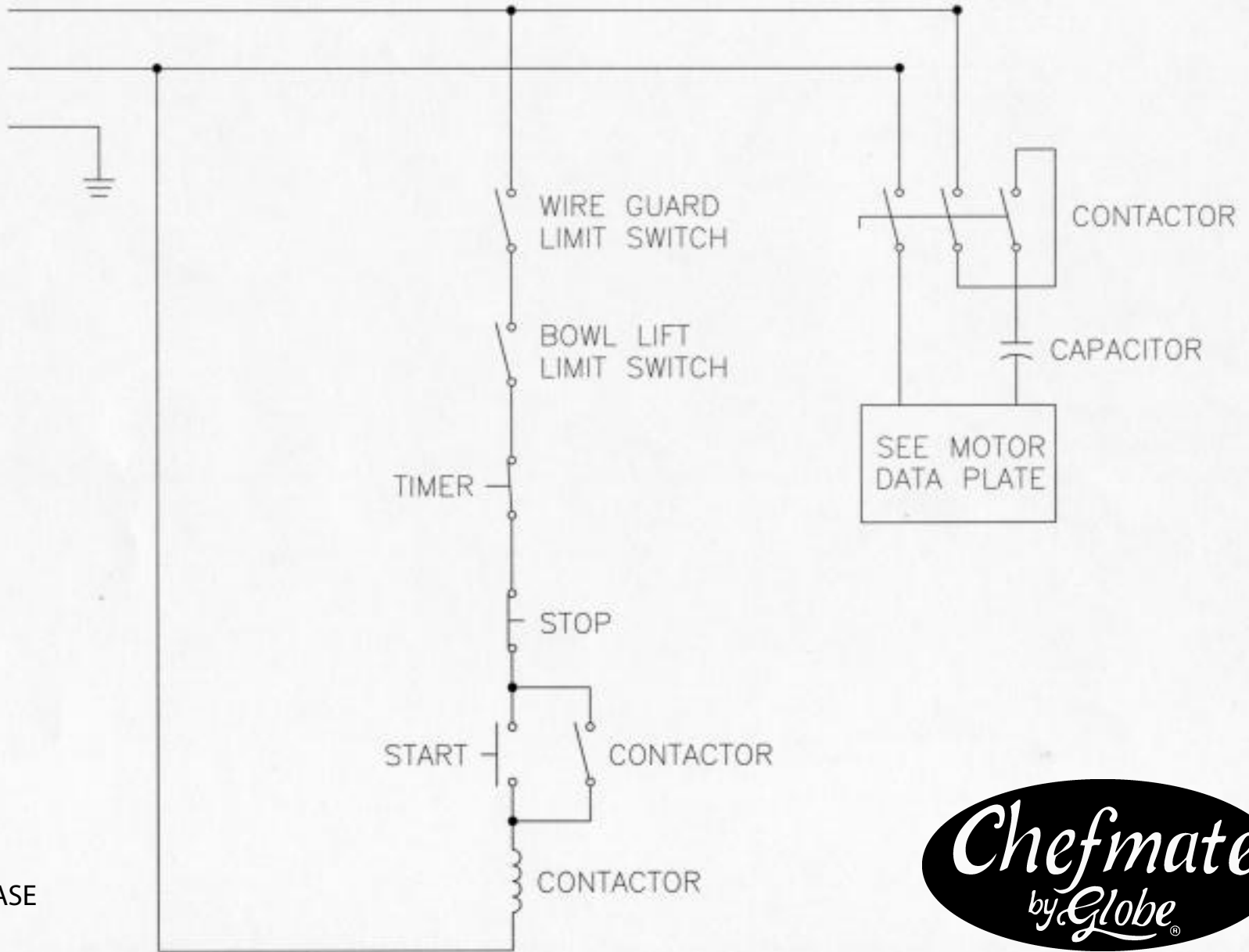

GCM30
SINGLE PHASE

PLANETARY MIXER — SINGLE PHASE



1. Start Switch
2. Stop Switch
3. Timer

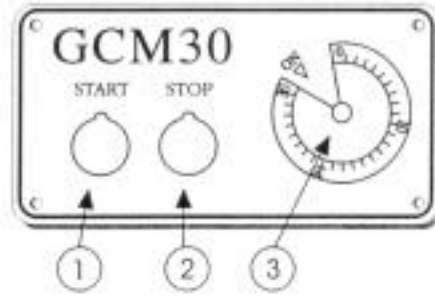

The model and serial number of the unit are found on the name plate on the back of the unit

