



Parts Catalogue



Model GCM40

MIXERS

MODEL:GCM40

1-1-2002

IMPORTANT!

TO EXPEDITE SHIPMENT OF PARTS, ALWAYS SPECIFY MODEL,REV,
PART NUMBER, AND SERIAL NUMBER OF MIXER.

GLOBE FOOD EQUIPMENT COMPANY

2268 N. Moraine Drive

Dayton, Ohio 45439

Parts Department

Toll Free 1-800-745-6238 • Fax (937) 290-0585

E-Mail: globeinfo@globeslicers.com

Website: www.globeslicers.com

Not for resale

1.a.	TIMER KNOB	X01214
b.	TIMER	X01215
2.a.	START BUTTON	X01216
b.	STOP SWITCH	X01217
c.	START SWITCH	X01218
d.	RED STOP BUTTON	X01234
3.	BALL BEARING	X01182
4.	BALL BEARING	X01181
5.	BALL BEARING	X01184
6.	PLANETARY SHAFT	X01096
7.	VARIATOR BELT	X01040
8.	RETURN SHAFT	X01011
9.	DRIVE PULLEY	X01010
10.	BALL BEARING	X01183
11.	VARIATOR GROUP	X01240
12.	VARIABLE PULLEY SHAFT	●
13.	VARIATOR COVER SPRING	●
14.	VARIATOR PULLEY SPRING	●
15.	SHOCK ABSORBER	X01155
16.	UPPER COVER	X01148
17.	*MOTOR SINGLE PHASE LAFERT	X01243
	*MOTOR THREE PHASE LAFERT	X01176
	*MOTOR THREE PHASE BALDOR	X01176B
18.	FLAT PLATE	X01031
19.	BOWL LIFTING PLATE	X01028
20.	BOWL LIFT POLES	X01029
21.	LEVELING FEET	X01266
22.	MICRO SWITCH	X01245
23.	ROUND MICRO SWITCH	X01020
24.	BLOCKING BOWL HANDLE	X01247
25.	BOWL	NA
26.	SLEEVE	X01221
27.	PROTECTION GRID	X01152
28.	BLOCKING	X01222
29.	TOOL SHAFT	X01013
30.	BALL BEARING	X01180
31.	BALL BEARING	X01178
32.	PLANETARY	X01012
33.	PLANETARY PINION	X01056
34.	TOOTHED CROWN	X01035
	*START CAPACITOR LAFERT	X01273
	*RUN CAPACITOR LAFERT	X01274
	*MOTOR RELAY LAFERT	X01275
	*THERMAL OVERLOAD 1 PHASE	X01276
	*THERMAL OVERLOAD 3 PHASE	X01277

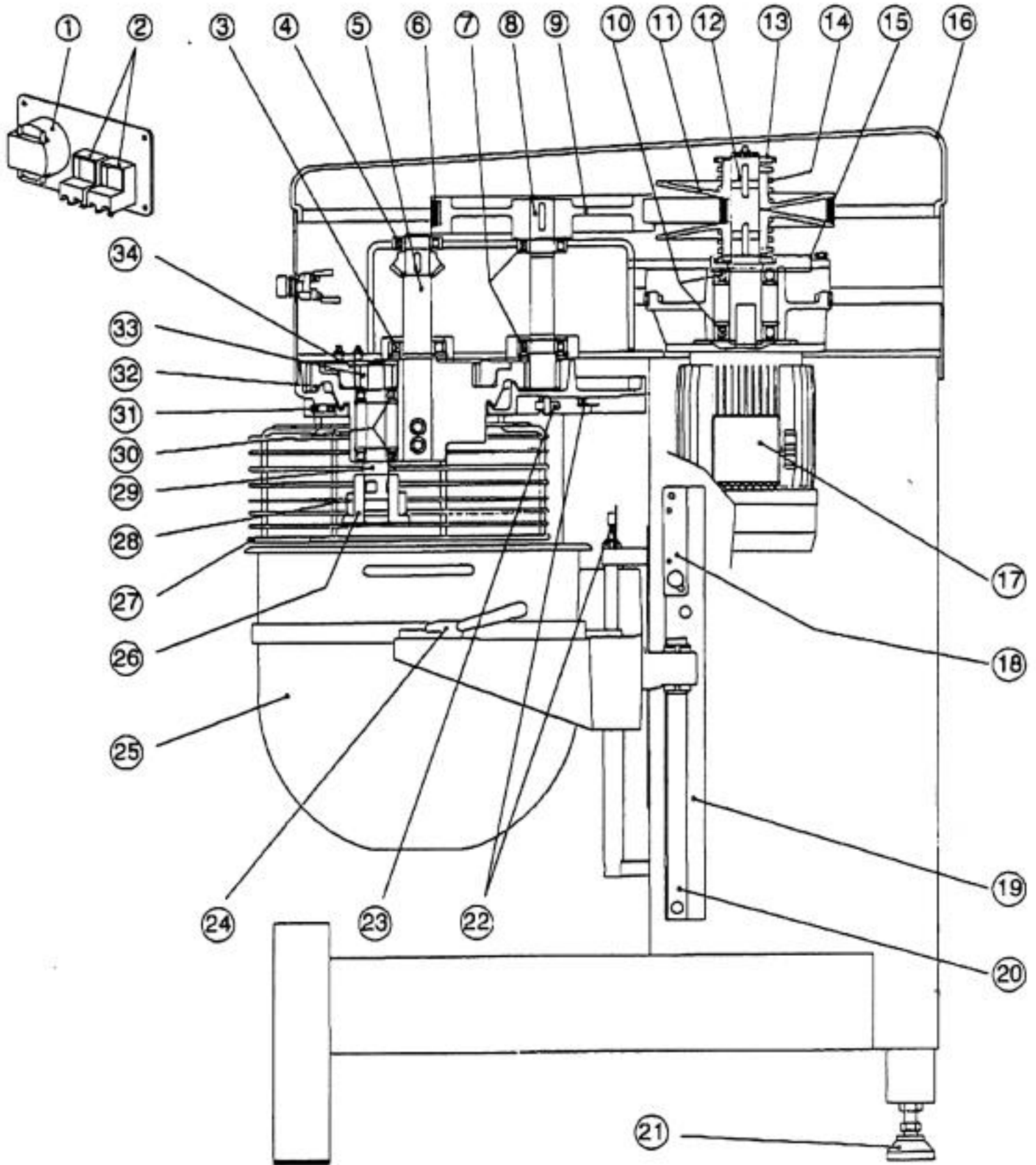

35.	WING SCREW	X01267
36.	BALL BEARING	X01179
37.	BEVEL GEAR PAIR REDUCER	X01068
38.	BEVEL GEAR PAIR REDUCER	X01015
39.	MOTOR CHAIR BARS	X01007
40.	RACK POLE	X01102
41.	SPEED SELECTING LEVER	X01025
42.	KNOB	X01189
43.	CLOSURE COVER	X01084
44.	SPEED PIN	X01024
45.	HANDLE SPRING	X01165
46.	SPEED LEVER SUPPORT	X01034
47.	KNOB	X01190
48.	TOOTHED WHEEL	X01023
49.	MOTOR CHAIR	X01006
50.	BOWL LIFT LEVER	X01032
51.	MICRO HOLDER	X01138
52.	BOWL BLOCKING TUBE	X01037
53.	CONTACTOR	X01213
54.	BOWL LIFT DRIVE POLES	X01027
55.	SHAFT FOR HUB	X01017
56.	HUB SUPPORT	X01016
57.	HUB CAP	X01268

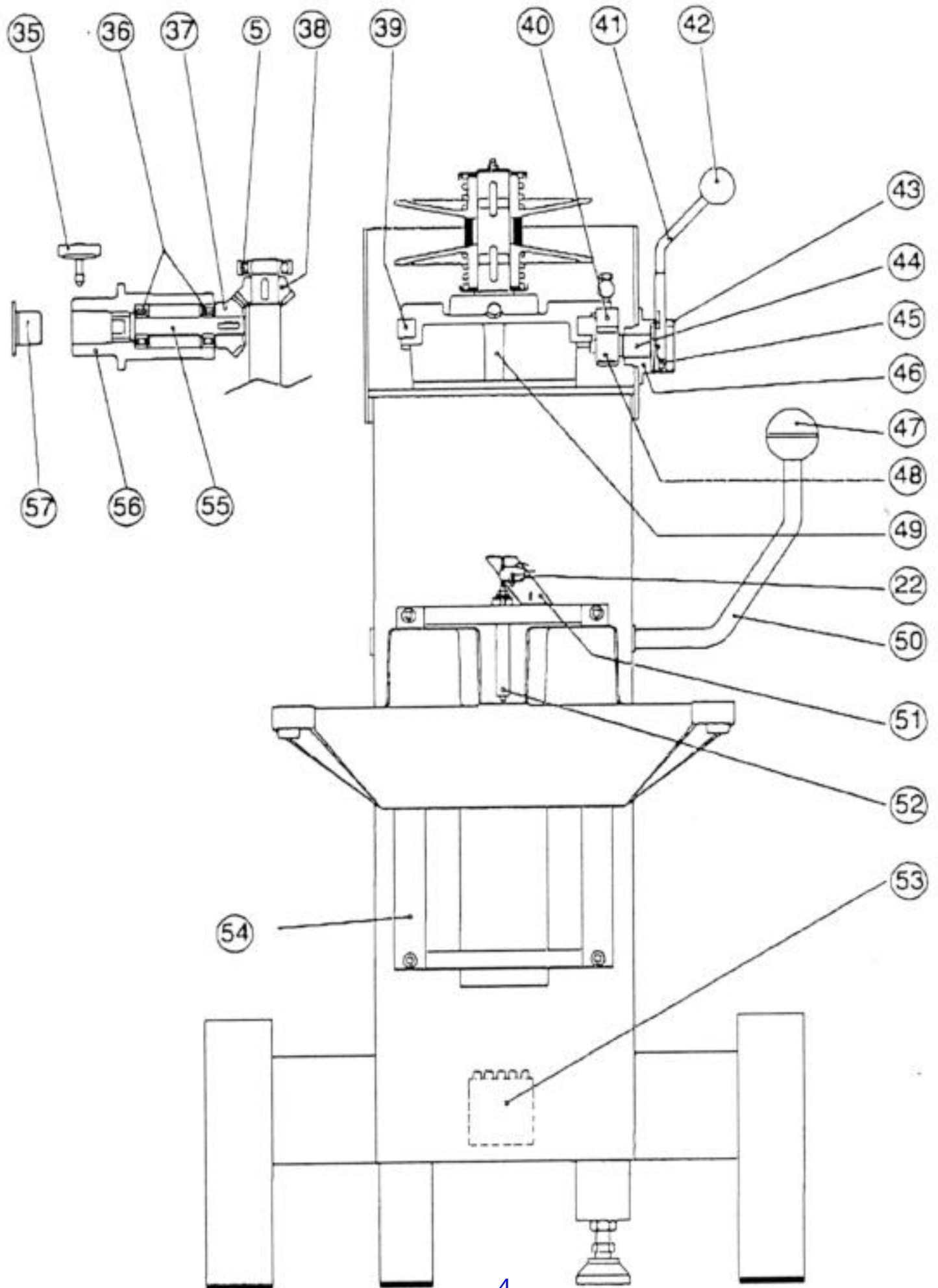

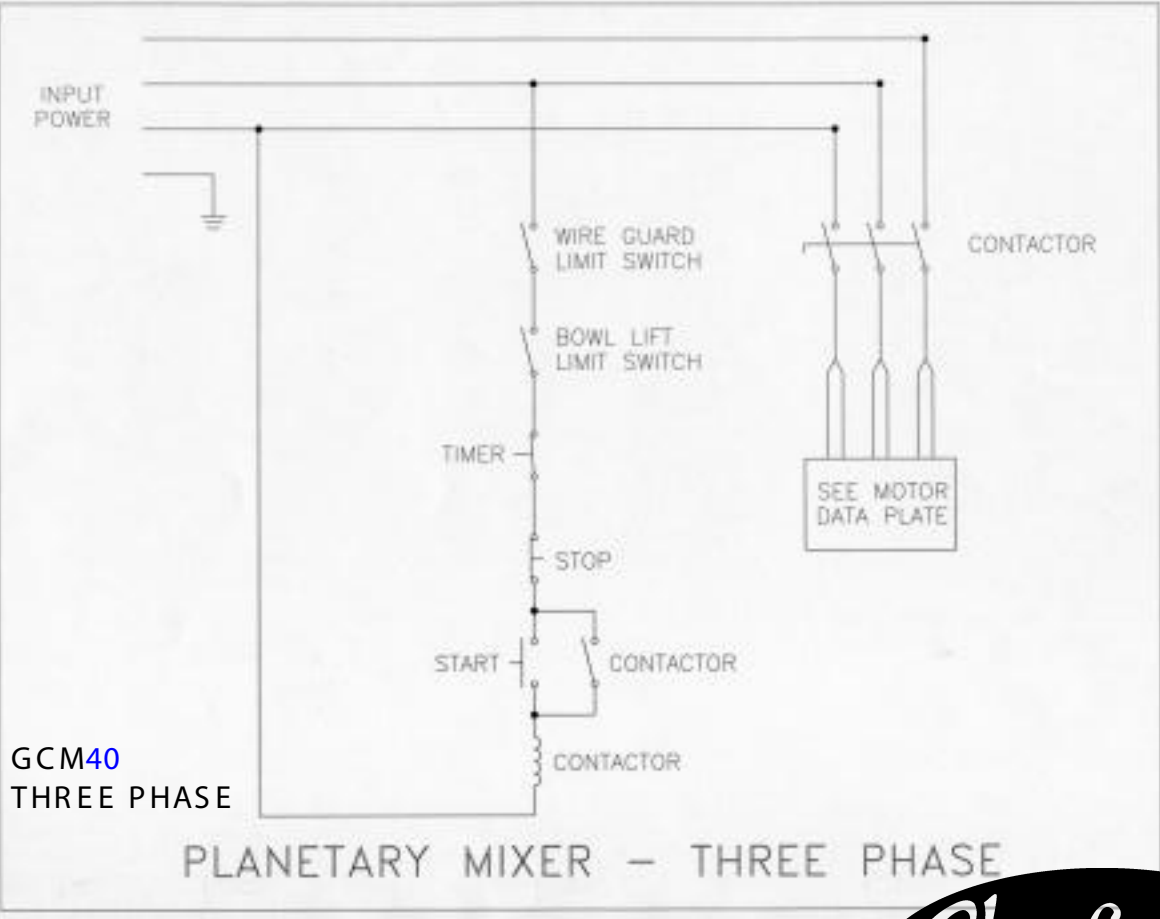
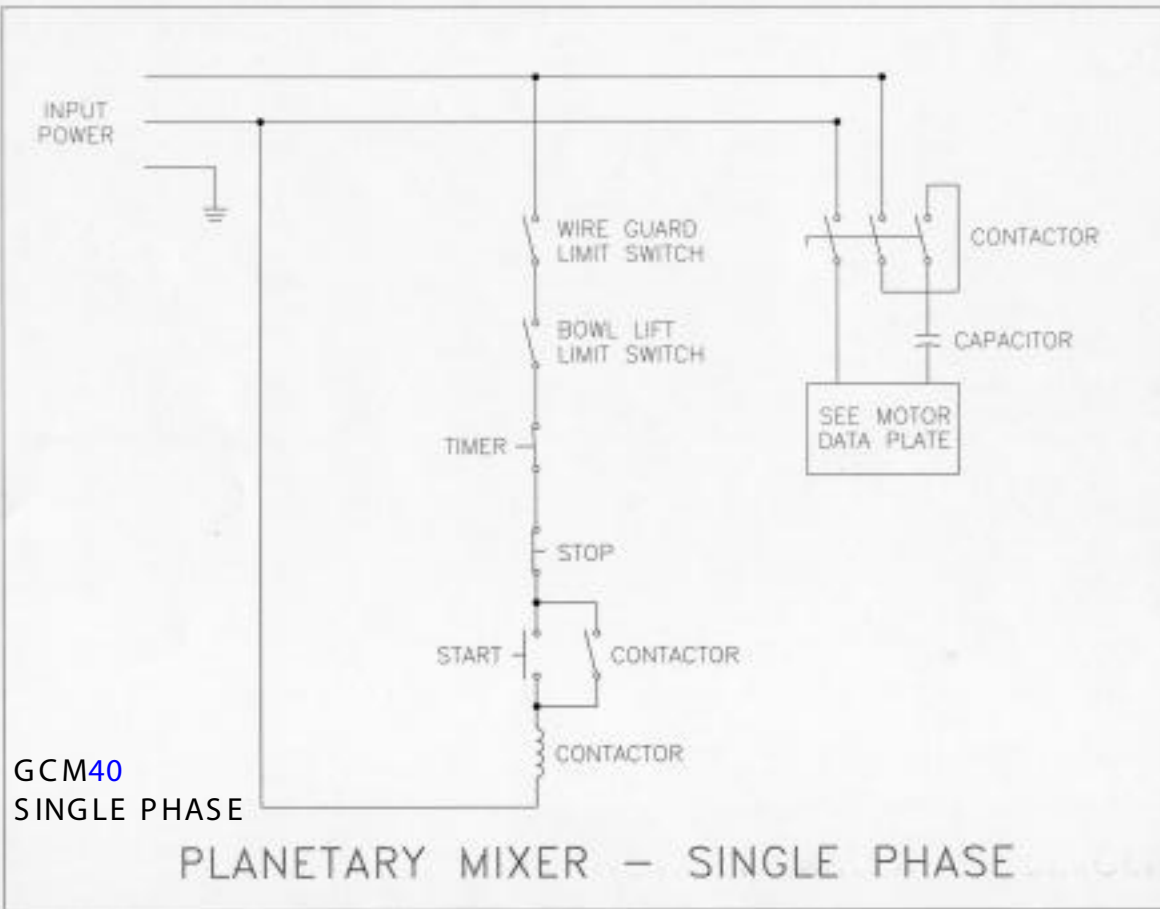

1. Start Switch
2. Stop Switch
3. Timer

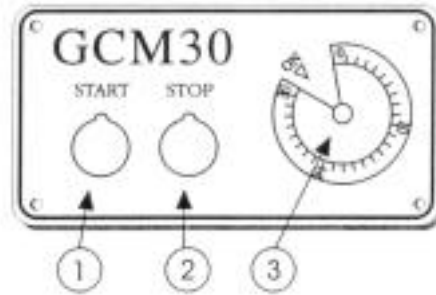

The model and serial number of the unit are found on the name plate on the back of the unit

