

Parts Catalog



GIB500-12

Immersion **B**lender

Model: GIB500-12

05/20/2026 Rev. C

IMPORTANT!

TO EXPEDITE SHIPMENT OF PARTS, ALWAYS SPECIFY MODEL, REV,
PART NUMBER, AND SERIAL NUMBER OF UNIT.

GLOBE FOOD EQUIPMENT COMPANY

2215 East River Road
Dayton, Ohio 45439

Parts Department

Toll Free 1-800-745-6238 · Fax (937) 290-0585

E-Mail: info@globefoodequip.com

Website: www.globefoodequip.com

Not for resale

Table of Contents

Description

Page

[GIB500-12 Blender Components](#)

4

[GIB500-12 Blender Tube Components](#)

6



GIB500-12 Blender Components

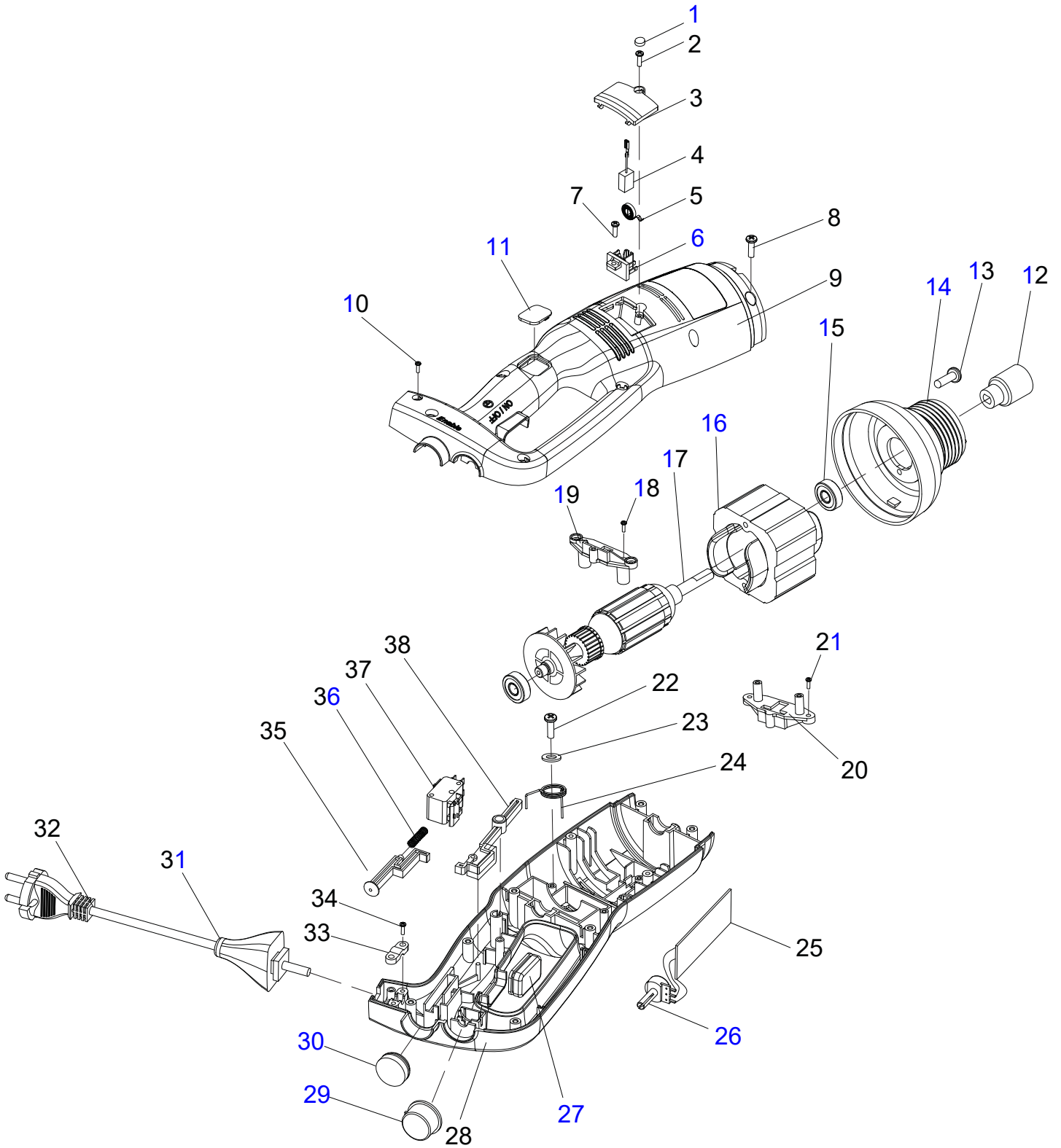



GIB500-12 Blender Components

Item	Part Number	Description	Qty	Serial Number
1	L02291	Screw Cover Kit Incls. all screw covers	1	
2	H02302	Screw 3mmx10mm Phillips	2	
3	L02290	Brush Cover	2	
4	L02289	Brush	3	
5	L02288	Spring, Brush	2	
6	L02287	Rack, Brush	2	
7	H02303	Screw M3x12mm Phillips	2	
8	H02298	Screw 3.9x15.5x.22mm Button PHH, Zinc	7	
9	L02206	Housing, Left	1	
10	H02297	Screw M3x15mm Phillips Zinc	1	
11	L02205	Cover	1	
12	L02207	Drive Hub	1	->GIB500-2404377
12	L03205	Drive Hub	1	GIB500N-26011401 ->
13	H02298	Screw 3.9x15.5x.22mm Button PHH, Zinc	2	
14	L02208	Coupling	1	
15	L02213	Bearing, Sealed	1	
16	L02209	Stator	1	
17	L02210	Rotor	1	
18	H02303	Screw M3x12mm Phillips	2	
19	L02211	Fixed Rack, Upper Brush	1	
20	L02212	Fixed Rack, Bottom Brush	1	
21	H02303	Screw M3x12mm Phillips	2	
22	H02298	Screw 3.9x15.5x.22mm Button PHH, Zinc	1	
23	L02224	Gasket	1	
24	L02225	Spring, Button	1	
25	L02226	Control Board, Speed	1	
26	L02234	Potentiometer	1	
27	L02223	Button, ON-OFF	1	
28	L02220	Housing, Right	1	
29	L02222	Knob, VARIABLE Speed	1	
30	L02221	Button, ENABLE	1	
31	L02218	Strain Relief	1	
32	L02219	Power Cord	1	
33	L02286	Tie Down	1	
34	H02301	Screw 4mmx15mm, Phillips Drive	2	
35	L02217	Bolt, Push	1	
36	L02216	Spring	1	
37	L02215	Microswitch	1	
38	L02214	Button, Osculant Staff	1	
39	L02284	Warning Label (Not Shown)	1	
40	L02285	French Warning Label (Not Shown)	1	
41	L02484	Double Insulation Warning Label (Not Shown)	1	



GIB500-12 Blender Tube Components

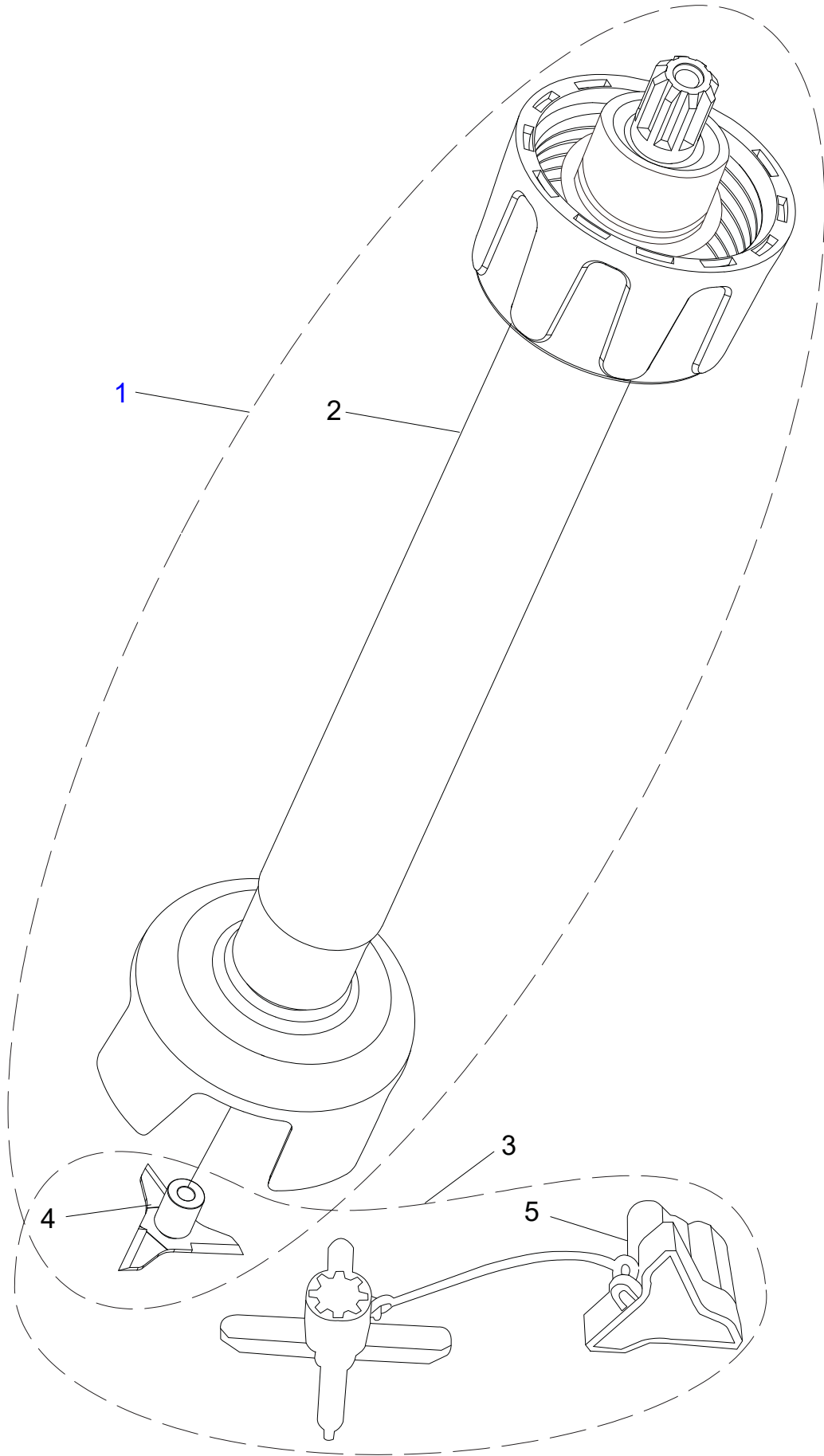

6



GIB500-12 Blender Tube Components

Item	Part Number	Description	Qty	Serial Number
1	L02327	12" Immersion Blender Stick Equivalent to GIBSTK12	1	
2		Blender Stick	1	
3	L02334	Blade Removal Kit Equivalent to GIB-BLADE TOOL	1	
4		Blade	1	
5		Blade Removal Tool	1	